

Technical Information

Gammapilot FMG50

Radiometric measurement



Compact transmitter for non-contact measurement through vessel walls

Application

- Level, interface, density, concentration and point level measurement
- Measurement in liquids, solids, suspensions or sludges
- Use under extreme process conditions
- All kinds of process vessels

Advantages

- Compact transmitter with loop-powered two-wire technology
- Multifunctional compact transmitter for all measuring tasks: level, interface, density, concentration and point level
- SIL2 approval according to IEC 61508 and SIL 3 for all measurement tasks with homogeneous or diverse redundancy
- Heartbeat Technology to verify the correct functioning of the measuring device within specifications without interrupting the process
- Optimum adjustment to the respective applications and measuring ranges via a variety of detector materials
- Bluetooth® wireless technology for easy commissioning, operation and maintenance via the free iOS / Android SmartBlue app
- Use of Gamma Modulator FHG65 for the reliable suppression of interference radiation irrespective of the isotope

Table of contents

About this document	4	Installation conditions for point level detection	27
Symbols used	4	Installation conditions for density measurement	28
Registered trademarks	4	Installation conditions for interface measurement	29
Function and system design	5	Installation conditions for density profile measurement (DPS)	30
Application and advantages	5	Installation conditions for concentration measurement . . .	30
Measuring principle	6	Installation conditions for concentration measurement with radiating media	31
Measuring system	8	Installation conditions for flow measurement	31
Signal analysis	9	Environment	32
System integration	13	Ambient temperature	32
Input	14	Climate class	32
Measured variable	14	Operating altitude as per IEC 61010-1 Edition 3.1	32
Sensitivity	14	Degree of protection	32
Typical pulse rates	14	Vibration resistance	32
Measuring range	15	Shock resistance	33
Output	17	Electromagnetic compatibility (EMC)	33
Output signal	17	Process conditions	33
Error signal	17	General	33
Load	17	Process temperature	33
Output damping	17	Process pressure	33
Power connection	17	Mechanical construction	33
Supply voltage	17	Dimensions, weights	33
Overvoltage category	17	Materials	34
Protection class	17	Measuring range marks	35
Potential equalization	17	Human interface	35
Electrical connection	17	Electronic insert / display	35
Connection compartment	17	Remote operation	35
4 to 20 mA HART connection	17	Local operation	37
Terminal assignment	18	Certificates and approvals	37
Cable entries	18	Functional safety	38
Potential equalization	19	Ex approval	38
Overvoltage protection (optional)	19	Other standards and guidelines	38
Rated cross-section	19	Certificates	38
Fieldbus connectors	19	CE mark	38
FMG50 with RIA15	21	EAC	38
Wiring	23	Overfill prevention	38
Wiring examples for point level detection	23	Ordering information	38
Post-connection check	24	Ordering information	38
Performance characteristics/stability	25	Application packages	39
Dead time, time constant, settling time	25	SIL wizard	39
Dynamic behavior, current output (HART electronics)	25	Heartbeat Diagnostics	39
Dynamic behavior, digital output (HART electronics)	25	Heartbeat Verification	40
Reference operating conditions	25	Heartbeat Monitoring	41
Measured value resolution	26	Accessories	41
Influence of ambient temperature	26	Commbobox FXA195 HART	41
Statistical fluctuation of the radioactive decay	26	Field Xpert SFX350, SFX370, SMT70	41
Installation conditions	27	Mounting device (for level and point level measurement) . .	42
General	27		
Installation conditions for level measurement	27		

Clamping device for density measurement FHG51 45
Process indicator RIA15 46

Supplementary documentation for Gammapilot

FMG50 46
Fields of activity 46
Operating Instructions 46
Description of Device Functions 47
Functional safety 47
Clamping device for density measurement 47

Supplementary documentation for radiation

source, source containers and modulator 47
Radiation source FSG60, FSG61 47
Source container FQG60 47
Source container FQG61, FQG62 47
Source container FQG61, FQG62 47
Source container FQG66 47
Gamma Modulator FHG65 47

About this document

Symbols used

Safety symbols

CAUTION

This symbol alerts you to a dangerous situation. Failure to avoid this situation can result in minor or medium injury.

DANGER

This symbol alerts you to a dangerous situation. Failure to avoid this situation will result in serious or fatal injury.

NOTICE

This symbol contains information on procedures and other facts which do not result in personal injury.

WARNING

This symbol alerts you to a dangerous situation. Failure to avoid this situation can result in serious or fatal injury.

Symbols for certain types of information



Warns against radioactive substances or ionizing radiation



Permitted

Procedures, processes or actions that are permitted



Preferred

Procedures, processes or actions that are preferred



Forbidden

Procedures, processes or actions that are forbidden



Tip

Indicates additional information



Reference to documentation

Symbols in graphics

1, 2, 3, ...

Item numbers

A, B, C, ...

Views

Registered trademarks

HART®

Registered trademark of the FieldComm Group, Austin, Texas, USA

Apple®

Apple, the Apple logo, iPhone, and iPod touch are trademarks of Apple Inc., registered in the U.S. and other countries. App Store is a service mark of Apple Inc.

Android®

Android, Google Play and the Google Play logo are trademarks of Google Inc.

Bluetooth®

The *Bluetooth*® word mark and logos are registered trademarks owned by the Bluetooth SIG, Inc. and any use of such marks by Endress+Hauser is under license. Other trademarks and trade names are those of their respective owners.

Function and system design

Application and advantages

Application

- Level, interface, density, concentration and point level measurement
- Measurement in liquids, solids, suspensions or sludges
- Use in extreme process conditions: high pressure, high temperature, corrosion, abrasion, viscosity, toxicity
- All kinds of process vessels, e.g. reactors, autoclaves, separators, acid tanks, cyclones

Advantages

- Compact transmitter with two-wire technology
 - Loop-powered: no separate evaluation unit necessary
 - Maximum safety thanks to intrinsically safe Ex-ia power supply
- Multifunctional compact transmitter for all measuring tasks: level, interface, density, concentration and point level
- SIL2 approval according to IEC 61508 and SIL 3 for all measurement tasks with homogeneous or diverse redundancy. Permanent process and device diagnostics with high level of diagnostic coverage.
- Heartbeat Technology:
 - Verification of the correct functioning of the measuring device within specifications without interrupting the process
 - Monitoring of internal device health parameters as part of "predictive maintenance" (in preparation)
- Variety of detectors ensure optimum adaptation to the individual applications and measuring ranges:
 - Thallium-doped sodium iodide (NaI (TI)) crystal scintillator, available in lengths 50 mm (2 in), 100 mm (4 in) and 200 mm (8 in)
 - Standard and high-temperature PVT scintillators up to 3 m (118.1 ft) in length
- Bluetooth® wireless technology for easy commissioning, operation and maintenance via the free iOS / Android SmartBlue app
- Easy, guided commissioning with intuitive user interface
- Easy proof testing for SIL and WHG
- 316L stainless steel housing for heavy-duty applications
- Use of Gamma Modulator FHG65 for the reliable suppression of interference radiation irrespective of the isotope

Highest availability, reliability and safety, even for extreme process and ambient conditions

Measuring principle

The radiometric measuring principle is based on the fact that gamma radiation is attenuated when it penetrates a material. Radiometric measurement can be used for a variety of measuring tasks:

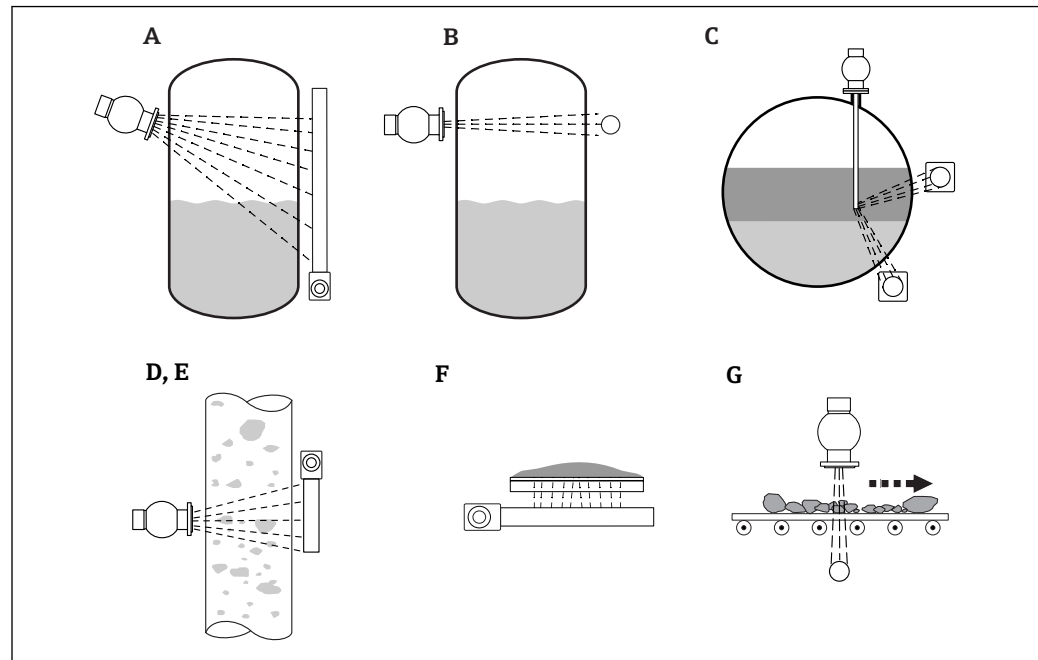

A001B108

- A Continuous level measurement
- B Point level detection
- C Interface measurement
- D Density measurement
- E Concentration measurement (density measurement followed by linearization)
- F Concentration measurement with radiating media
- G Measurement of mass flow (solids)

Continuous level measurement

A source container with a radiation source and a Gammapilot FMG50 (to receive the gamma radiation) are mounted on opposite sides of a vessel. The radiation emitted by the radiation source is absorbed by the medium in the vessel. The higher the level rises, the more radiation is absorbed. Consequently, the Gammapilot FMG50 receives less radiation as the level of the medium increases. This effect is used to determine the current level of medium in the vessel. As the Gammapilot FMG50 is available in different lengths, the detector can be used for measuring ranges of different sizes.

Point level detection

A source container with a radiation source and a Gammapilot FMG50 (to receive the gamma radiation) are mounted on opposite sides of a vessel. The radiation emitted by the radiation source is absorbed by the medium in the vessel. In the case of point level detection, the radiation received by the Gammapilot FMG50 is usually absorbed completely if the radiation path between the radiation source and the detector is completely filled with medium. In this case, the level of the medium in the vessel is at the set limit. The Gammapilot FMG50 indicates the uncovered state (no medium in the radiation path) with 0% and the covered state (radiation path filled with medium) with 100%.

Density measurement

A source container with a radiation source and a Gammapilot FMG50 (to receive the gamma radiation) are mounted on opposite sides of a pipe. The radiation emitted by the radiation source is absorbed by the medium in the pipe. The denser the medium in the radiation path between the radiation source and the detector, the more radiation is absorbed. Consequently, the Gammapilot FMG50 receives less radiation as the density of the medium increases. This effect is used to determine the current density of the medium in the pipe. The density unit can be selected from a menu.

Density measurement to determine the mass flow

A source container with a radiation source and a Gammapilot FMG50 (to receive the gamma radiation) are mounted on opposite sides of a pipe. The radiation emitted by the radiation source is absorbed by the medium in the pipe. The denser the medium in the radiation path between the radiation source and the detector, the more radiation is absorbed. Consequently, the Gammapilot FMG50 receives less radiation as the density of the medium increases. This effect is used to determine the current density of the medium in the pipe. The density unit can be selected from a menu. The density signal of the Gammapilot FMG50 can be combined with the signal of a volume flowmeter, e.g. Promag 55S, and the mass flow can be calculated from these two signals.



Additional features are required when ordering a Promag 55S for mass flow measurement:

- **Order option:** "Solids stream" software function (F-CHIP)
- **Order option:** Current input

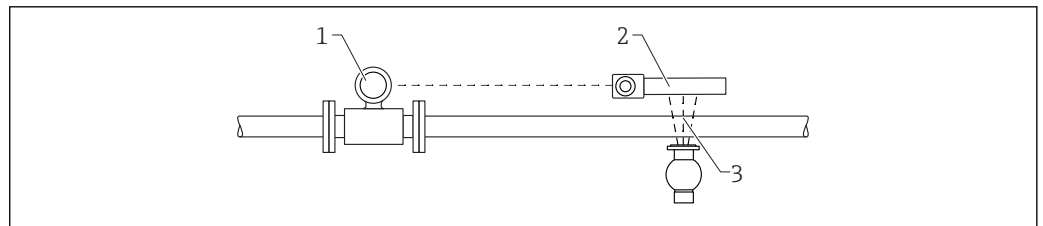

A0038166

- 1 Volume flowmeter
- 2 Gammapilot
- 3 Density measurement

Concentration measurement

A source container with a radiation source and a Gammapilot FMG50 (to receive the gamma radiation) are mounted on opposite sides of a vessel. The radiation emitted by the radiation source is absorbed by the medium in the vessel. The denser the medium in the radiation path between the radiation source and the detector, the more radiation is absorbed. Consequently, the Gammapilot FMG50 receives less radiation as the density of the medium increases. This effect is used to determine the current density of the medium in the vessel. Using the linearization function, the corresponding concentration can be assigned to the medium density and the Gammapilot FMG50 displays concentration values. The concentration unit can be selected from a menu.

Concentration measurement with radiating media

The Gammapilot FMG50 is mounted on the side of a measuring pipe. Radiating medium is conducted past the Gammapilot. The Gammapilot FMG50 can determine the concentration of the radiating content in the medium based on the intensity of the gamma radiation given off by the radiating medium.

Interface measurement

A source container with a radiation source and a Gammapilot FMG50 (to receive the gamma radiation) are mounted on opposite sides of a vessel. If an FQG63 source container is used, the radiation source can also be inserted into a vessel using an immersion tube. This excludes the possibility of contact between the radiation source and the medium. The radiation emitted by the radiation source is absorbed by the media in the vessel. The denser the medium in the radiation path between the radiation source and the detector, the more radiation is absorbed. Consequently, the Gammapilot FMG50 receives less radiation as the density of the medium increases. This effect is used to determine the current density of the medium in the vessel. The Gammapilot FMG50 calculates the position of the interface layer from the intensity of the radiation received. Its value is between 0% (lowest possible position) and 100% (highest possible position).

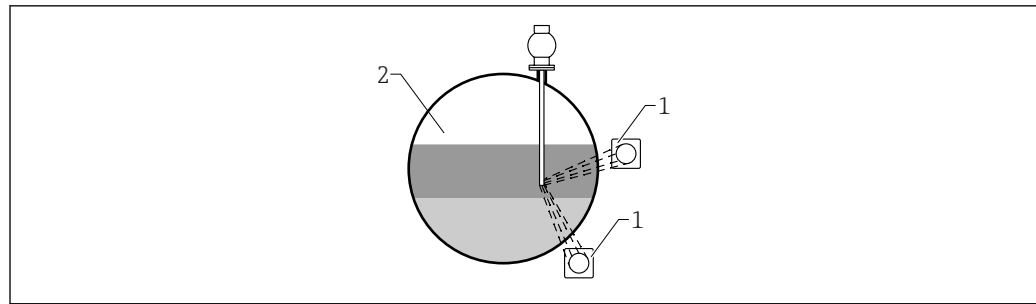

A0038167

- 1 Gammapilot (2 pcs)
- 2 Interface measurement

Measurement of mass flow (solids)

Bulk solids applications on conveyor belts and conveyor screws.

The source container is positioned above the conveyor belt and the Gammapilot FMG50 below the conveyor belt. The radiation is attenuated by the medium on the conveyor belt. The intensity of the radiation received is proportional to the density of the medium. The mass flow is calculated from the belt speed and the radiation intensity.

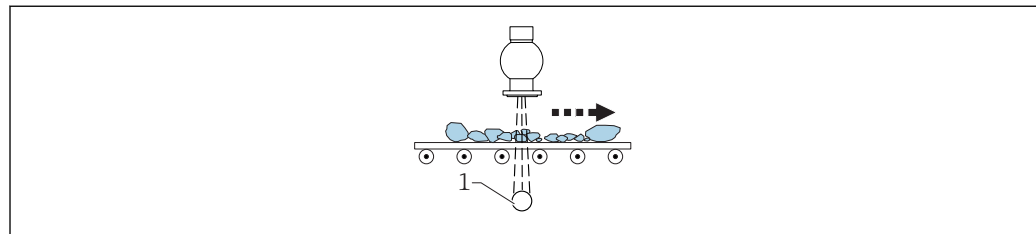

A0036637

- 1 Gammapilot FMG50

Measuring system

A radiometric measuring system typically consists of the following components:

Radiation source

A ^{137}Cs or ^{60}Co source acts as the radiation source. Radiation sources with different activities are available to adapt the system to the specific application. The "Applicator" selection and configuration program can be used to calculate the required activity¹⁾. For additional information on the radiation source, refer to TI00439F.

i Alternatively, radiation sources with other decay constants can also be used. The decay time can be defined as between 1 and 65536 days. Decay times for other isotopes can be found in the "NIST Standard Reference Database 120", see:

<https://www.nist.gov/pml/radionuclide-half-life-measurements/radionuclide-half-life-measurements-data>

Source container

The radiation source is enclosed in a source container, which allows the radiation to be emitted only in one direction and screens it off in any other direction. The radiation is absorbed in all directions when the source container is closed. The source container is opened during commissioning and the radiation is emitted at a defined angle. This reduces the area of radioactive radiation to the minimum required to irradiate the active part of the Gammapilot FMG50. Source containers are available in different sizes and with different angles of emission. The "Applicator"¹⁾ program can be used to select the source container that suits your application. For additional information on source containers, refer to Technical Information TI00445F (FQG60), TI00435F (FQG61, FQG62), TI00446F (FQG63) and TI01171F (FQG66).

1) The "Applicator" CD-ROM is available from your E+H sales organization

Gammapilot FMG50

The Gammapilot FMG50 contains a scintillator, a photomultiplier and the electronic evaluation unit. Incident gamma radiation generates light flashes within the scintillator. These pass to the photomultiplier, where they are converted into electrical pulses and amplified. The pulse rate (number of pulses per second) is an indicator of the intensity of the radiation. Depending on the calibration, the pulse rate is converted to a level, limit switching, density or concentration signal by the electronic evaluation unit. The Gammapilot FMG50 is available with NaI (Tl) crystals or with PVT scintillators of different lengths, ensuring that it can be optimally adapted to each individual application.

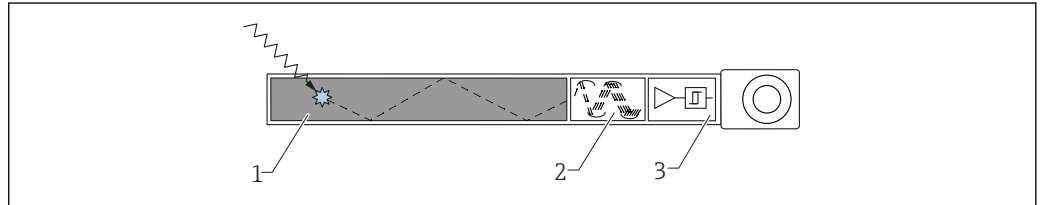

A0018244

- 1 Gamma radiation generates light flashes (photons) in the scintillator
- 2 The photomultiplier converts the flashes into electrical pulses and amplifies them
- 3 The electronic evaluation unit calculates the measured value from the pulse rate

Gamma Modulator FHG65 (optional)

In a radiometric measuring point with a Gammapilot FMG50, the Gamma Modulator FHG65 is mounted in front of the radiation emission channel of the source container. It contains a shaft slotted along the longitudinal axis. This shaft rotates continuously and alternately screens off the gamma beam at a frequency of 1 Hz or allows it through. Due to this frequency, the useful beam differs from fluctuating ambient interference radiation and from interference radiation occurring sporadically (e.g. from nondestructive material testing). Using a frequency filter, the Gammapilot FMG50 can separate the useful signal from interference radiation. In this way, it is possible to continue measuring even if interference radiation occurs. This significantly increases the measuring certainty and system availability. This is independent of the interference radiation isotope used.

For additional information, refer to TI00423F

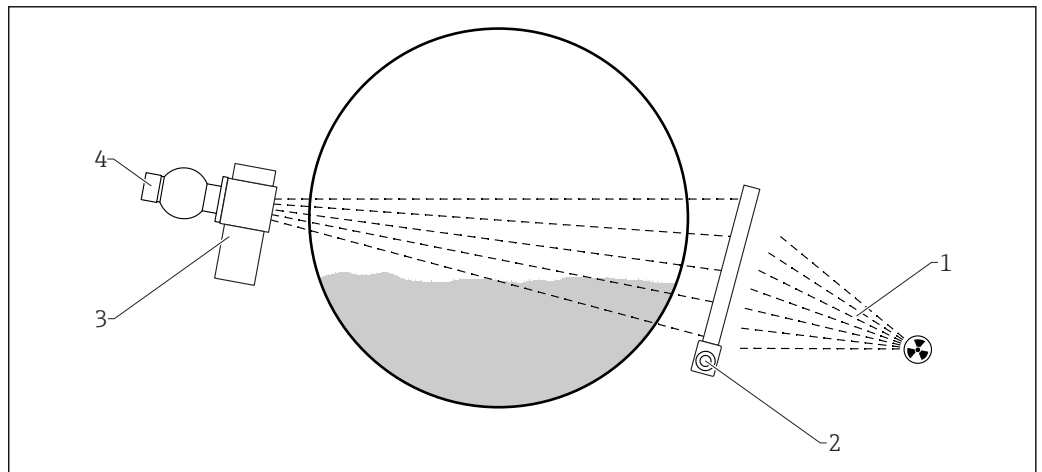

A0018245

- 1 Interference radiation
- 2 Gammapilot FMG50
- 3 Gamma Modulator FHG65
- 4 Source container FQG61, FQG62

i The gamma modulator FHG65 and the Gammapilot FMG50 are not interconnected electrically. When adjusting the Gammapilot, the "Beam type" parameter must be set to "Modulated".

Signal analysis

Level measurement

The device's linearization function allows the user to convert the measured value to length or volume units. A standard linearization curve for calculating the level in vertical cylinders is preprogrammed

into the Gammapilot M. Other linearization tables of up to 32 value pairs can be entered manually or semi-automatically. The linearization curve with its associated table can be calculated using the "Applicator" ¹⁾ selection and configuration software.

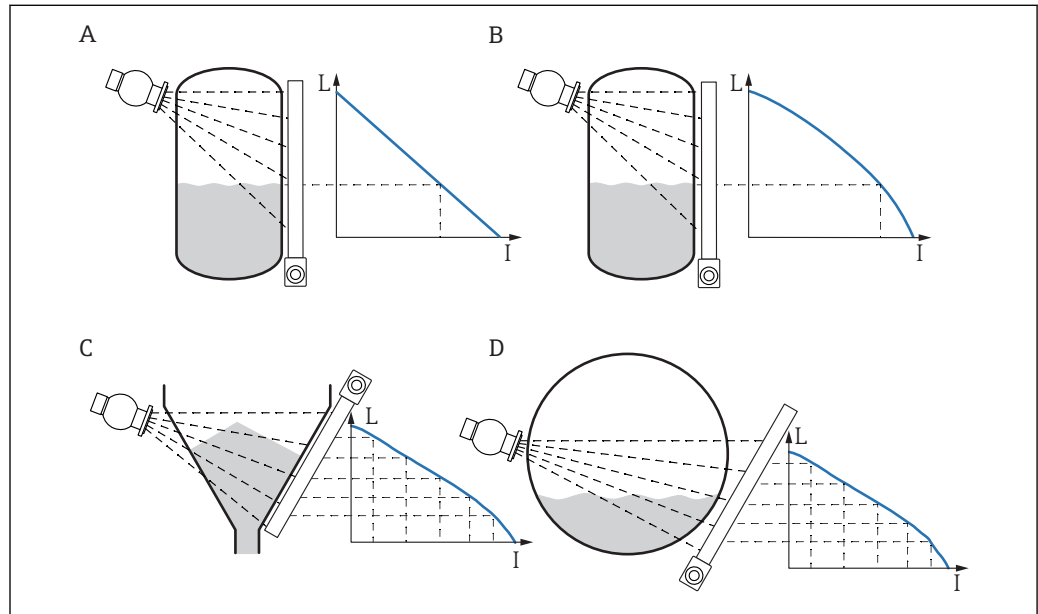

A0018246

- A Linear table
 B Standard table
 C, D User-specific table
 I Pulse rate (pulses per second, cnt/s)
 L Level (%)

Density measurement

The measured values of up to four samples of known density can be stored in the Gammapilot FMG50 and used for the calibration of density measurements. The Gammapilot FMG50 calculates the absorption coefficient μ and the linearization curve automatically from these values. It then uses these parameters to calculate the density from the pulse rate. In the case of a one-point calibration, a default value is used for the absorption coefficient μ . This value can be changed manually. Alternatively, a second calibration point (the pulse rate in the empty pipe) can be calculated using the Applicator. The calculated empty calibration value of the Applicator is saved in the device with the measured one-point calibration value and the absorption coefficient μ is calculated from this.

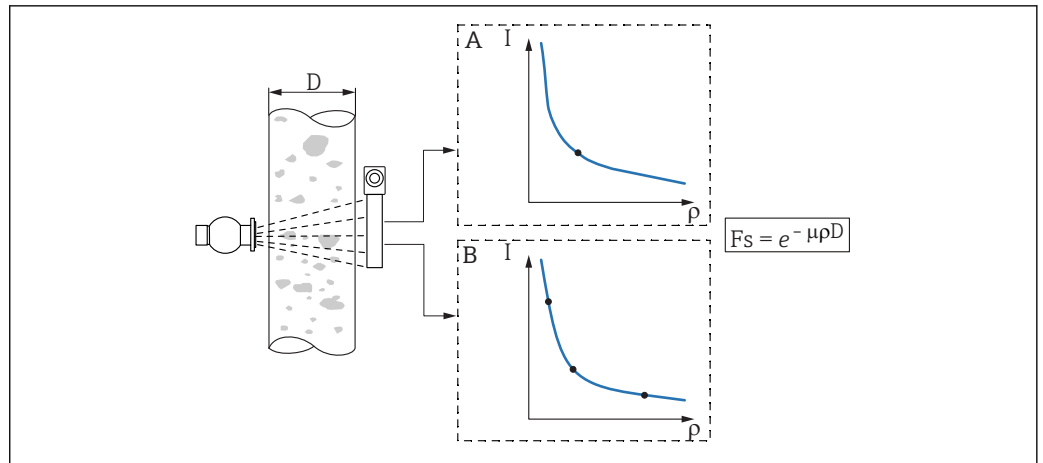

- A One-point calibration
- B Multiple point calibration
- D Pipe diameter or radiated length
- I Pulse rate (pulses per second, cnt/s)
- F_s Attenuation factor
- ρ Density
- μ Absorption coefficient

Concentration measurement

The Gammapilot FMG50 determines the concentration indirectly via a density measurement. A linearization table consisting of up to 32 "density - concentration" value pairs can be entered for this calculation. The solids content of liquids, for example, can be measured in this way (percentage of volume or weight).

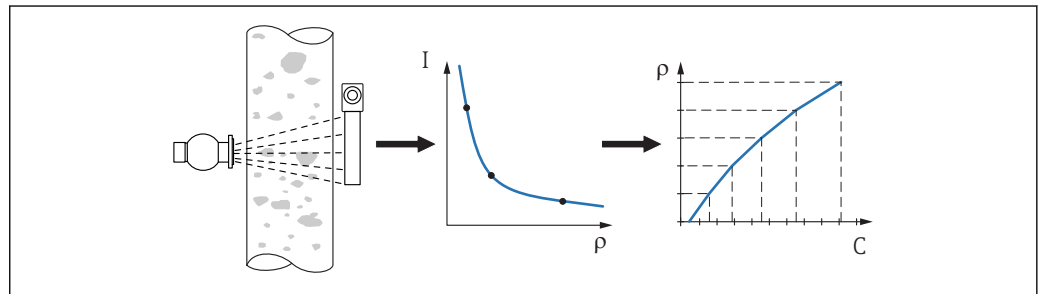

- I Pulse rate (pulses per second, cnt/s)
- ρ Density
- C Concentration

Concentration measurement with radiating media

The Gammapilot FMG50 calculates the concentration of the medium from the intensity of the radiation that is emitted by the medium itself.



A source container and radiation source are not needed for the measurement

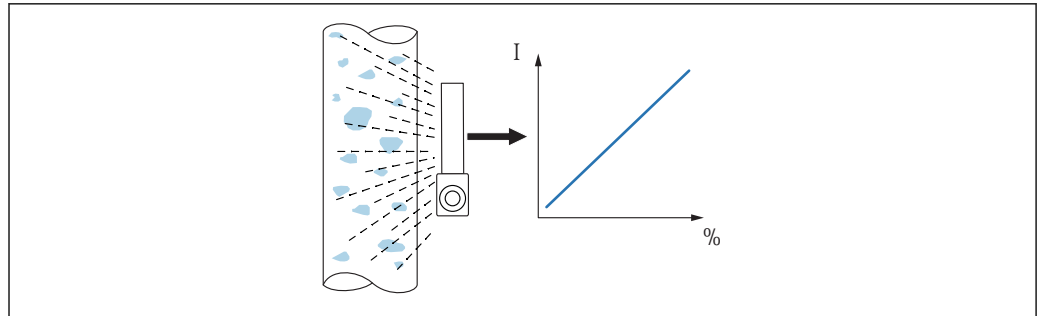

A0038876

I Pulse rate (pulses per second, cnt/s)
 $\%$ Measured value

Measurement of mass flow (liquids)

The density signal determined by the Gammapilot FMG50 is transmitted to the Promag 55S. The Promag 55S measures the volume flow; the Promag can determine a mass flow in connection with the calculated density value.

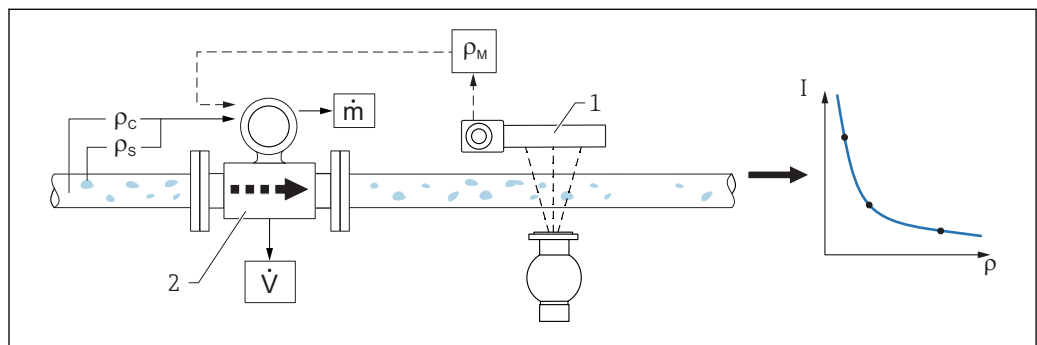

A0042020

1 Mass flow measurement (m) using a density meter and a flowmeter. If the density of the solids (ρ_s) and the density of the carrier liquid (ρ_c) are also known, the solids flow rate can be calculated.

- 1 Gammapilot FMG50 -> total density (ρ_m) consisting of the carrier liquid and solids
- 2 Flowmeter (Promag 55S) -> volume flow (V). The solids density (ρ_s) and the density of the carrier liquid (ρ_c) also have to be entered in the transmitter
- I Pulse rate (pulses per second, cnt/s)
- ρ Density

Measurement of mass flow (solids)

Bulk solids applications on conveyor belts and conveyor screws.

The source container is positioned above the conveyor belt and the Gammapilot FMG50 below the conveyor belt. The radiation is attenuated by the medium on the conveyor belt. The intensity of the radiation received is proportional to the density of the medium. The mass flow is calculated from the belt speed and the radiation intensity.

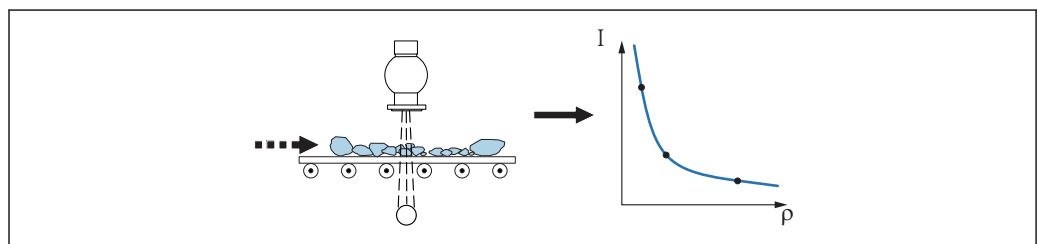

A0042021

I Pulse rate (pulses per second, cnt/s)
 ρ Density

General functions

Decay compensation

The automatic decay compensation function of the Gammapilot FMG50 compensates for the decrease in the activity of the radiation source as a result of radioactive decay. Accurate measurements are therefore possible over the entire operating time of the radiation source.

The following are possible:

- ⁶⁰Co
- ¹³⁷Cs
- No decay compensation
- Custom:
Decay indicated in whole days



For other elements see:

<https://www.nist.gov/pml/radionuclide-half-life-measurements/radionuclide-half-life-measurements-data>

Gammagraphy detection

The Gammapilot FMG50 has a function to detect short-term interference radiation. This function displays a message if the measurement is affected by non-destructive gammagraphic material tests in the vicinity of the measuring point.



Excess radiation: In the event of excess radiation, the Gammapilot FMG50 automatically switches off the evaluation of the radiation. The device checks the radiation regularly. As soon as the Gammapilot FMG50 establishes that the radiation has normalized or no more radiation is detected, it resumes normal operation.



Empty pipe detection: see Operating Instructions

System integration

Via HART protocol

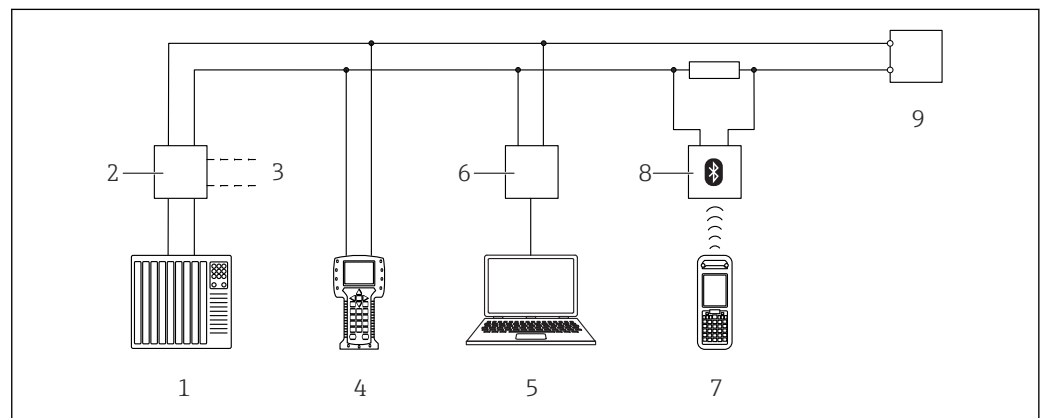

2 Options for remote operation via HART protocol

- 1 PLC (programmable logic controller)
- 2 Transmitter power supply unit, e.g. RN221N (with communication resistor)
- 3 Connection for Commubox FXA191, FXA195 and Field Communicator 375, 475
- 4 Field Communicator 475
- 5 Computer with operating tool (e.g. DeviceCare/FieldCare, AMS Device Manager, SIMATIC PDM)
- 6 Commubox FXA191 (RS232) or FXA195 (USB)
- 7 Field Xpert SFX350/SFX370
- 8 VIATOR Bluetooth modem with connecting cable
- 9 Transmitter

Operation via the service interface

- Service interface (CDI) of the measuring device (= Endress+Hauser Common Data Interface)
- Commubox FXA291
- Computer with DeviceCare/FieldCare operating tool

Operation via HART

- With Field Xpert SFX350/SFX370
- With the Commubox FXA195 and the "FieldCare" operating program

Operation via WirelessHART

SWA70 WirelessHART adapter with the Commubox FXA195 and the "FieldCare" operating program

Operation via Bluetooth LE and "SmartBlue APP"

Local operation outside the radiation path



Input

Measured variable

The Gammapilot FMG50 measures the pulse rate (number of pulses per second). This rate is proportional to the intensity of radiation at the detector. The Gammapilot M calculates the measured value from this rate:

- Point level (0% = "radiation path free"; 100% = "radiation path covered")
- Level (in % or selectable units)
- Position of interface (in %)
- Density (selectable unit)
- Concentration (selectable unit)

Pulse rate:

Max. 60000 cnt/s

Sensitivity

The sensitivity indicates which pulse rate occurs at a local dose rate of 1 $\mu\text{Sv/h}$. The sensitivity depends on the following parameters:

- Type of scintillator
- Measuring range
- Isotope used

NaI (TI) scintillator

Sensitivity with lateral irradiation:

- ^{137}Cs : 675 [(cnt/s)/($\mu\text{Sv/h}$)] per "inch" measuring range
- ^{60}Co : 450 [(cnt/s)/($\mu\text{Sv/h}$)] per "inch" measuring range
- K_2O : 10 [(cnt/s)/% K_2O] per "inch" measuring range

PVT scintillator

Sensitivity with lateral irradiation

- ^{137}Cs : 10 [(cnt/s)/($\mu\text{Sv/h}$)] per "mm" measuring range
- ^{60}Co : 5 [(cnt/s)/($\mu\text{Sv/h}$)] per "mm" measuring range

Typical pulse rates

A radiometric measuring point should be designed in a way such that the following pulse rates, approximately, are obtained:

Level measurement (with empty vessel)

- 2500 cnt/s for ^{137}Cs
- 5000 cnt/s for ^{60}Co

Point level detection (with free radiation path)

- 500 cnt/s for ^{137}Cs
- 1000 cnt/s for ^{60}Co

Density, concentration, interface and mass flow measurements

- 5000 cnt/s for ¹³⁷Cs
- 5000 cnt/s for ⁶⁰Co

Density and concentration measurements

- Depends on the application; for more information contact Endress+Hauser Service or the "Gamma Project Team" (gamma@endress.com)
- Applicator
<https://www.de.endress.com/de/onlinetools/life-cycle-management/Planung-Engineering-Rueckverfolgbarkeit/Applicator-Produktauswahl-Produktauslegung>

i An application can deliver satisfactory measurement results even if the pulse rate is higher or lower than the values specified here. For more information contact Endress+Hauser Service or the "Gamma Project Team" (gamma@endress.com)

Measuring range

Level measurement

In the case of level measurement, the measuring range typically depends on the height of the vessel. To cover the entire measuring range, a scintillator is used that is longer than the measuring range. Several Gammapilot FMG50 units can be used for measuring ranges >3 m (9.84 ft).

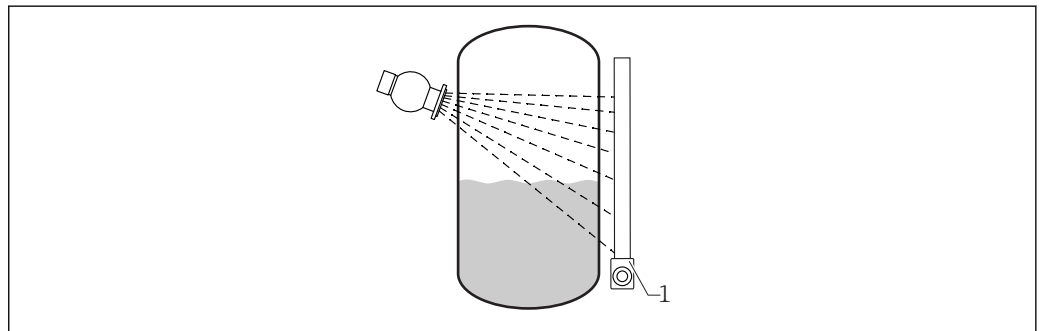

A0037672

1 Gammapilot FMG50

Max. point level detection

In the case of point level detection, the measuring range is essentially at one specific point. It is determined by the thickness of the scintillator (42 mm (1.65 in)).

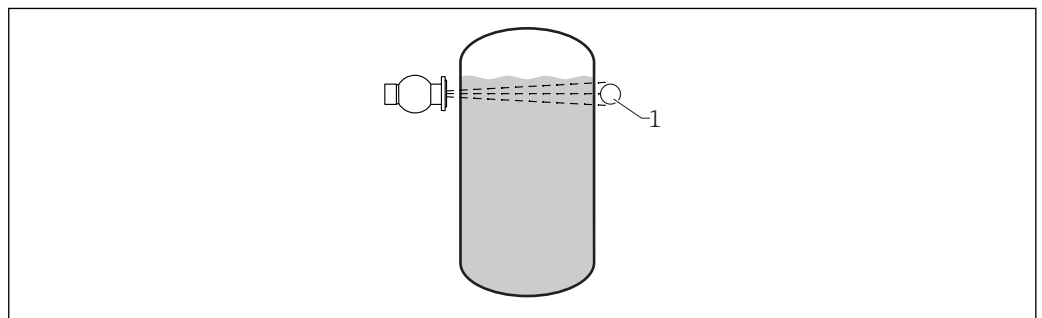

A0036644

1 Gammapilot FMG50

Min. Point level detection

In the case of point level detection, the measuring range is essentially at one specific point. It is determined by the thickness of the scintillator (42 mm (1.65 in)).

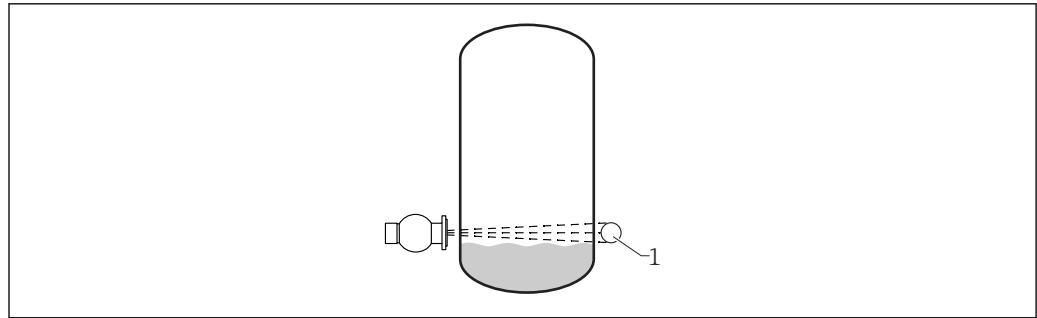

A0036646

1 Gammapilot FMG50

Density measurement

In the case of density measurement, the density measuring range is defined by the minimum and maximum density of the measured medium.

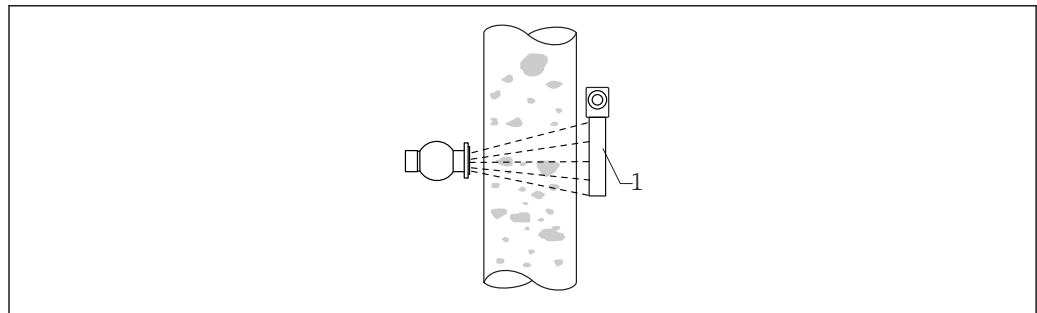

A0036645

1 Gammapilot FMG50

Interface measurement

In the case of interface measurement, the measuring range is determined by the possible position of an interface. Here, the 0% position is at the lowest possible point where the interface is to be monitored, while the 100% position is at the highest point.

Concentration measurement with source container and radiation source

In the case of concentration measurement, the measuring range is defined by the minimum and maximum concentration of the measured medium.

Concentration measurement with radiating media

In the case of radiating media, the measuring range is defined by the minimum and maximum concentration of the medium.

Measurement of mass flow

For the FMG50, mass flow measurement constitutes a density measurement.

The density measuring range is defined by the minimum and maximum density of the measured medium.

Conditions/prerequisites for applications in safety-related operation

See the Functional Safety Manual

"Slave" operating mode: in this measuring mode, the measured pulse rate is output for further processing in a connected controller.



This mode is not permitted for "functional safety"

Output

Output signal	<p>4 to 20 mA with HART protocol</p> <p>The current output offers a choice of three different operating modes:</p> <ul style="list-style-type: none"> ■ 4.0 to 20.5 mA ■ NAMUR NE043: 3.8 to 20.5 mA ■ US mode: 3.9 to 20.8 mA
Error signal	<p>Errors occurring during commissioning or operation are signaled in the following way:</p> <ul style="list-style-type: none"> ■ Error symbol, error code and error description on the display module. ■ Current output: <ul style="list-style-type: none"> ■ MAX, 110%, 22 mA ■ MIN, -10%, 3.6 mA
Load	<ul style="list-style-type: none"> ■ Max. load: 500 Ω ■ Min. load for HART communication: 250 Ω
Output damping	The output damping is user-definable in the range from 0 to 999.9 s

Power connection

Supply voltage	<p>Protected against reverse polarity</p> <ul style="list-style-type: none"> ■ Non-Ex: 14 to 35 V_{DC} ■ Ex-i: 14 to 30 V_{DC} <p>i Bluetooth communication with the device is possible with a supply voltage of 14 V or higher. The background lighting of the display is only guaranteed with a supply voltage ≥ 16 V. The measurement function is guaranteed as of a terminal voltage of 12 V; Bluetooth communication with the device is not possible with this voltage level, however.</p> <p>i If the available supply voltage drops below the aforementioned thresholds during operation, the background lighting switches off first before the Bluetooth function is switched off in order to guarantee the measurement function. A corresponding warning message is not displayed. These functions are reactivated when the device is restarted and sufficient power is supplied.</p>
Overvoltage category	<ul style="list-style-type: none"> ■ Overvoltage category II ■ Pollution degree II
Protection class	Class 1
Potential equalization	The device must be included in the local potential equalization system.

Electrical connection

Connection compartment

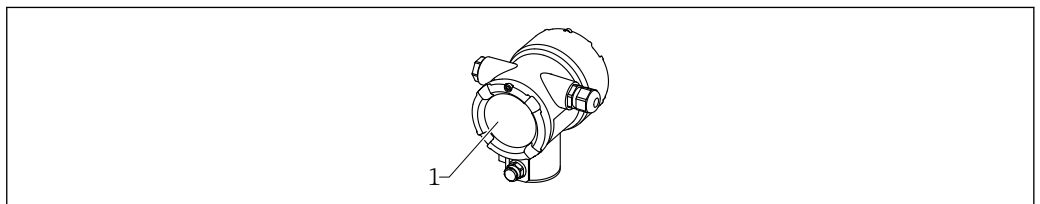

1 Connection compartment

4 to 20 mA HART connection	Connection of the device with HART communication, power source and 4 to 20 mA display
-----------------------------------	---

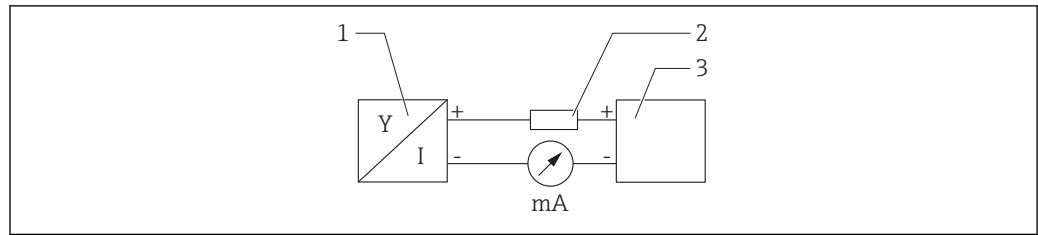

3 Block diagram of HART connection

- 1 Device with HART communication
- 2 HART resistor
- 3 Power supply

i The HART communication resistor of 250 Ω in the signal line is always necessary in the case of a low-impedance power supply.

The voltage drop to be taken into account is:
Max. 6 V for 250 Ω communication resistor

Terminal assignment

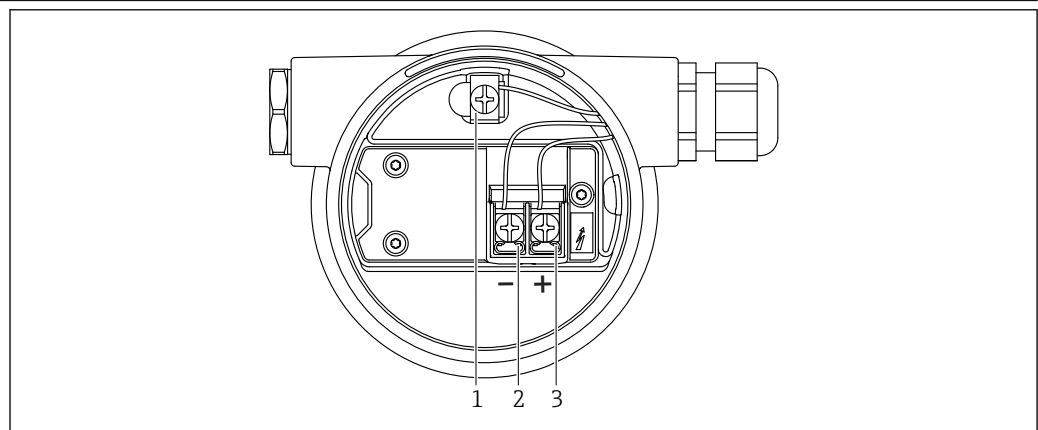

4 Connection terminals and ground terminal in the connection compartment

- 1 Internal ground terminal (to ground the cable shield)
- 2 Negative terminal
- 3 Positive terminal

- Non-Ex: supply voltage: 14 to 35 VDC
- Ex-i: supply voltage: 14 to 30 VDC

Cable entries

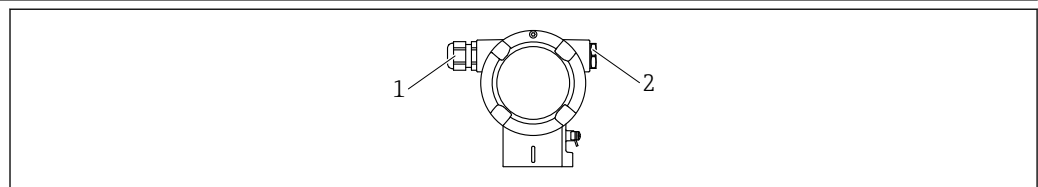

- 1 Cable entry
- 2 Dummy plug

The number and type of cable entries depend on the device version ordered. The following are possible:

- M20 threaded joint, plastic, IP66/68 NEMA Type 4X/6P
- M20 threaded joint, nickel-plated brass, IP66/68 NEMA Type 4X/6P
- M20 threaded joint, 316L, IP66/68 NEMA Type 4X/6P
- M20 thread, IP66/68 NEMA Type 4X/6P
- G1/2 thread, IP66/68 NEMA Type 4X/6P, with enclosed M20 to G1/2 adapter

- NPT1/2 thread, IP66/68 NEMA Type 4X/6P
- M12 plug, IP66/68 NEMA Type 4X/6P
- HAN7D plug, 90 deg. IP65 NEMA Type 4x

i Connecting cables should be routed away from the housing from below to prevent moisture from penetrating the connection compartment. Otherwise, a drip loop should be provided or a weather protection cover should be used.

i Please follow the enclosed installation instructions if a G1/2 entry is used.

Potential equalization

Before wiring, connect the potential matching line to the ground terminal.

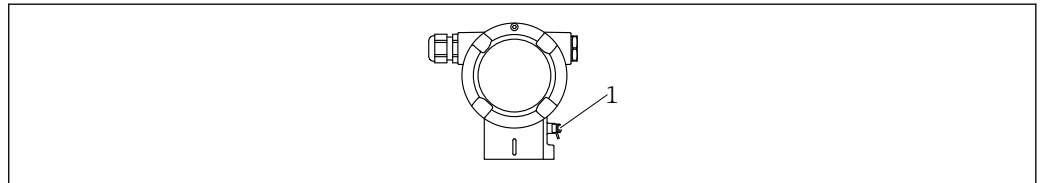

1 Ground terminal for connecting the potential matching line

CAUTION

▶ Please refer to the separate documentation on applications in hazardous areas for the safety instructions

i For optimum electromagnetic compatibility, the potential matching line should be as short as possible and at least 2.5 mm² (14 AWG) in cross-section.

Overvoltage protection (optional)

Product structure, feature 610 "Accessory mounted", option "NA"

- Overvoltage protection:
 - Nominal functioning DC voltage: 600 V
 - Nominal discharge current: 10 kA
- Surge current check $\hat{i} = 20$ kA satisfied as per DIN EN 60079-14: 8/20 μ s
- Arrester AC current check $I = 10$ A satisfied

NOTICE

Device could be destroyed!

▶ Devices with integrated overvoltage protection must be grounded.

Rated cross-section

Protective ground or grounding of the cable shield: rated cross-section > 1 mm² (17 AWG)
 Rated cross-section of 0.5 mm² (AWG20) to 2.5 mm² (AWG13)

Fieldbus connectors

In the case of device versions with a fieldbus connector, the housing does not have to be opened to establish the connection.

Pin assignment for connector M12-A

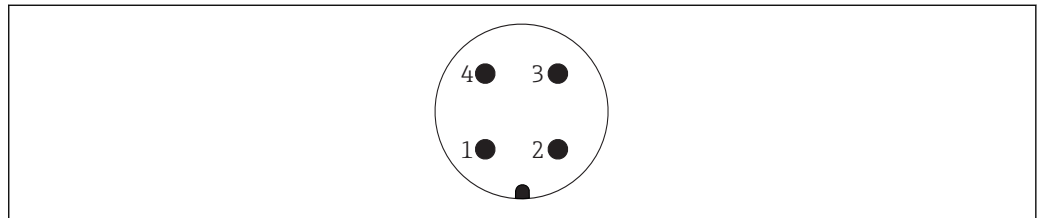

- Pin 1: Signal +
- Pin 2: Not used
- Pin 3: Signal -
- Pin 4: Ground

Material: CuZn, contacts for plug-in jack and connector are gold-plated

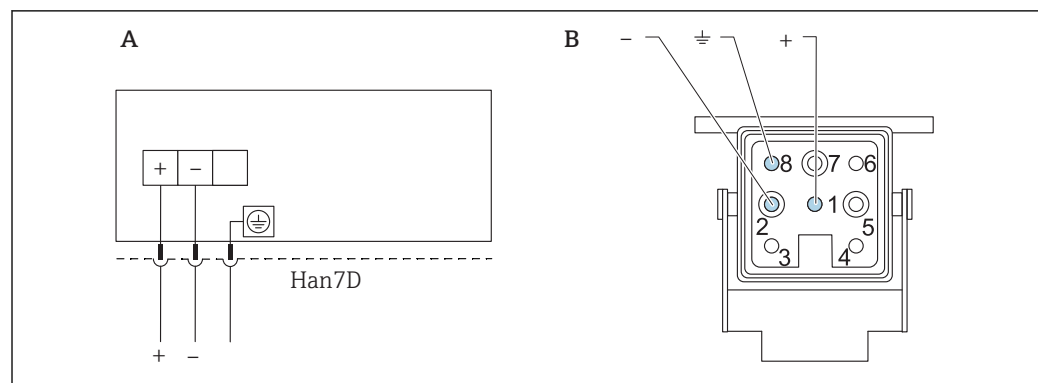
Connection of devices with Harting plug Han7D

A Electrical connection for devices with Harting plug Han7D

B View of the plug-in connection on the device

Material: CuZn, contacts for plug-in jack and connector are gold-plated

FMG50 with RIA15

 The RIA15 remote indicator can be ordered together with the device.

Product structure, feature 620 "Accessory enclosed":

- Option PE "Remote indicator RIA15, non-hazardous area, aluminum field housing"
- Option PF "Remote indicator RIA15, hazardous, aluminum field housing"

 Alternatively available as an accessory, for details see Technical Information TI01043K and Operating Instructions BA01170K

CAUTION

► Pay attention to the Safety Instructions (XAs) when using the Gammapilot FMG50 with the remote indicator RIA15 in hazardous environments:

- 
- XA01028R
 - XA01464K
 - XA01056K
 - XA01368K
 - XA01097K

Terminal assignment RIA15

- +
Positive connection, current measurement
- -
Negative connection, current measurement (without backlighting)
- LED
Negative connection, current measurement (with backlighting)
- \perp
Functional grounding: terminal in housing

 The RIA15 process indicator is loop-powered and does not require any external power supply.

The voltage drop to be taken into account is:

- ≤ 1 V in the standard version with 4 to 20 mA communication
- ≤ 1.9 V with HART communication
- and an additional 2.9 V if display light is used

Connection of the HART device and RIA15 without backlighting

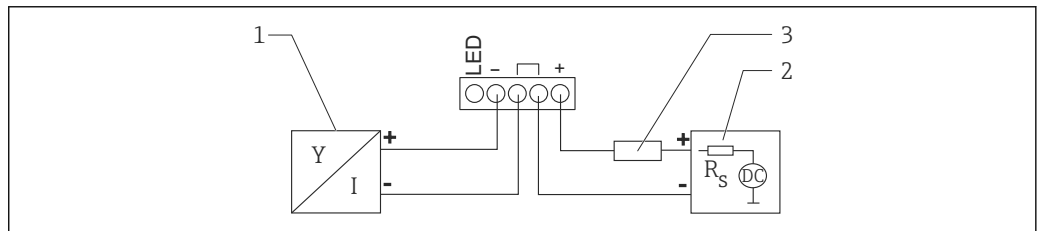

A0019567

 5 Block diagram of HART device with RIA15 process indicator without light

- 1 Device with HART communication
- 2 Power supply
- 3 HART resistor

Connection of the HART device and RIA15 with backlighting

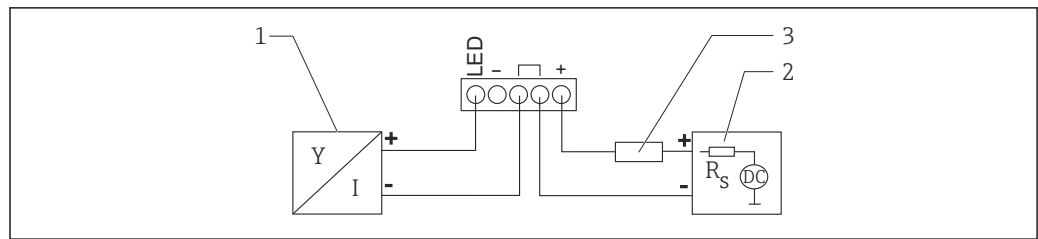

A0019568

6 Block diagram of HART device with RIA15 process indicator with light

- 1 Device with HART communication
- 2 Power supply
- 3 HART resistor

FMG50, RIA15 with installed HART communication resistor module

i The HART communication module for installation in the RIA15 can be ordered together with the device.

Product structure, feature 620 "Accessory enclosed":

Option PI "HART communication resistor for RIA15"

The voltage drop to be taken into account is:

Max. 7 V

📖 Alternatively available as an accessory, for details see Technical Information TI01043K and Operating Instructions BA01170K

Connection of the HART communication resistor module, RIA15 without backlighting

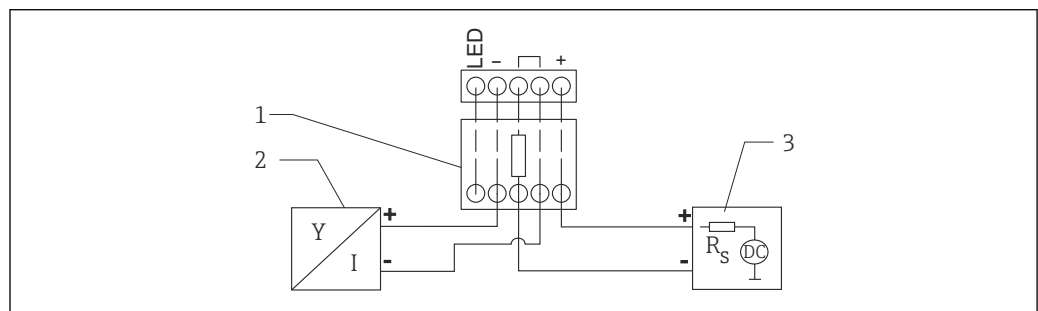

A0020839

7 Block diagram of HART device, RIA15 without light, HART communication resistor module

- 1 HART communication resistor module
- 2 Device with HART communication
- 3 Power supply

Connection of the HART communication resistor module, RIA15 with backlighting

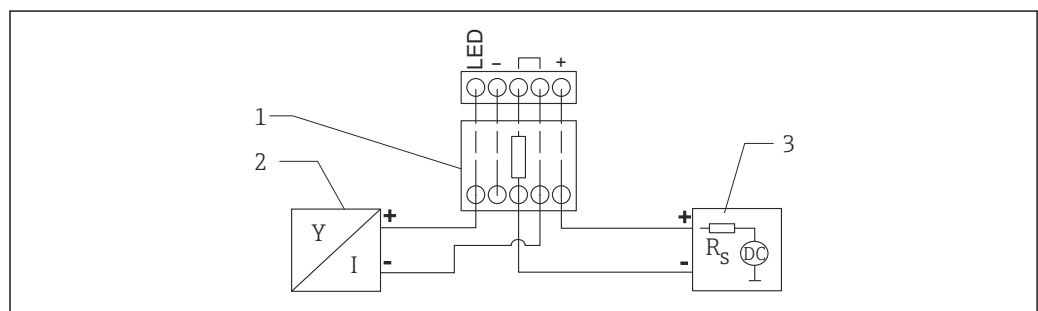

A0020840

8 Block diagram of HART device, RIA15 with light, HART communication resistor module

- 1 HART communication resistor module
- 2 Device with HART communication
- 3 Power supply

Wiring**⚠ CAUTION****Note the following before connecting:**

- ▶ If the device is used in hazardous areas, make sure to comply with national standards and the specifications in the Safety Instructions (XAs). The specified cable gland must be used.
- ▶ The supply voltage must match the specifications on the nameplate.
- ▶ Switch off the supply voltage before connecting the device.
- ▶ Connect the potential matching line to the external ground terminal of the transmitter before connecting the device.
- ▶ Connect the protective ground to the protective ground terminal.
- ▶ The cables must be adequately insulated, with due consideration given to the supply voltage and the overvoltage category.
- ▶ The connecting cables must offer adequate temperature stability, with due consideration given to the ambient temperature.

1. Release the cover lock
2. Unscrew the cover
3. Guide the cables into the cable glands or cable entries
4. Connect the cables
5. Tighten the cable glands or cable entries so that they are leak-tight
6. Screw the cover securely back onto the connection compartment
7. Tighten the cover lock

Wiring examples for point level detection

The output signal is linear between free and covered adjustment (e.g. 4 to 20 mA) and can be evaluated in the control system. If a relay output is needed, the following Endress+Hauser process transmitters can be used:

- RTA421: for non-Ex applications, without WHG (German Water Resources Act), without SIL
- RMA42: for Ex-applications, with SIL certificate, with WHG

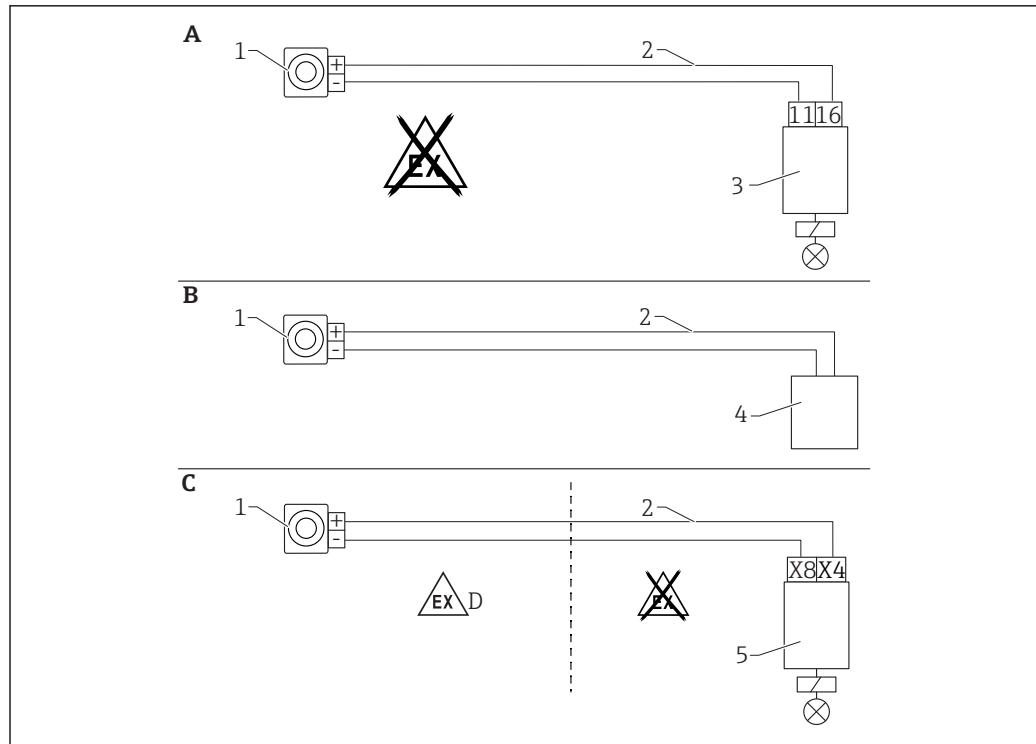

A0018092

- A Wiring with RTA421 switching unit
- B Wiring with control system (pay attention to the explosion protection regulations)
- C Wiring with RMA42 switching unit
- D When installing in hazardous areas, please observe the corresponding Safety Instructions
- 1 Gammapilot FMG50
- 2 4 to 20 mA
- 3 RTA421
- 4 PLC (pay attention to the explosion protection regulations)
- 5 RMA42

Ex applications in conjunction with RMA42

Observe the following Safety Instructions:

ATEX II (1) G [Ex ia] IIC, ATEX II (1) D [Ex ia] IIIC for RMA42

XA00095R

SIL applications for Gammapilot in connection with RMA42

The Gammapilot FMG50 meets the requirements of SIL2/3 as per IEC 61508, see:

FY01007F

The RMA42 meets SIL2 as per IEC 61508:2010 (Edition 2.0), see the Functional Safety Manual:

SD00025R

Post-connection check

After wiring the device, carry out the following checks:

- Is the potential matching line connected?
- Is the terminal assignment correct?
- Are the cable glands and dummy plugs screwed tight?
- Are the fieldbus connectors properly secured?
- Are the covers screwed down correctly?

⚠ WARNING

- ▶ Only operate the device with the covers closed

Performance characteristics/stability

Dead time, time constant, settling time

Presentation of the dead time, time constant and settling time as per DIN EN 61298-2

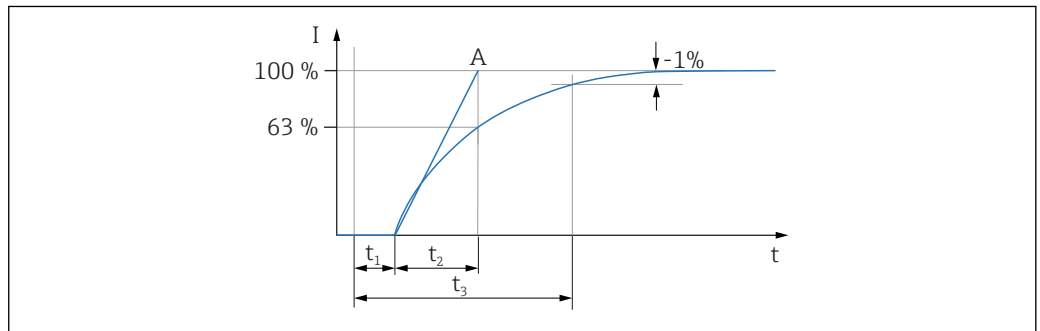

A0042012

- t_1 Dead time
- t_2 Time constant
- t_3 Settling time
- A Stable full scale value

Dynamic behavior, current output (HART electronics)

- Dead time (t_1):
 - Unmodulated: 250 ms
 - Modulated: 400 ms
- Time constant T63 (t_2): adjustable 0.0 to 999.9 s
- Settling time (t_3):
 - Unmodulated: minimum 450 ms
 - Modulated: minimum 20 s

Dynamic behavior, digital output (HART electronics)

- Dead time (t_1):
 - **Unmodulated:**
 - Minimum: 400 ms
 - Maximum: 1 210 ms
 - **Modulated:**
 - Minimum: 4 150 ms
 - Maximum: 4 960 ms
- Time constant T63 (t_2):
 - Minimum: 310 ms + adjustable 0.0 to 999.9 s
 - Maximum: 1 100 ms + adjustable 0.0 to 999.9 s
- Settling time (t_3):
 - Unmodulated: minimum 600 ms
 - Modulated: minimum 21 s

Reading cycle

- Acyclic: max. 3/s, typical 1/s (depends on command # and number of preambles)
- Cyclic (burst): max. 3/s, typical 2/s

The device commands the BURST MODE function for cyclic value transmission via the HART communication protocol.

Cycle time (update time)

Cyclic (burst): min. 300 ms

Reference operating conditions

- Temperature: 20 °C (68 °F), ±10 °C (±50 °F)
- Pressure: 1 013 mbar (15 psi), ±20 mbar (±0.29 psi)
- Humidity: not relevant

Measured value resolution 1 μ A

Influence of ambient temperature

NaI (Tl) crystal

- Temperature range: -40 to +50 °C (-40 to +122 °F)
Influence of ambient temperature: +- 0.1%
- Temperature range: -40 to +80 °C (-40 to +176 °F)
Ambient temperature effect: -0.1 to +0.7 %

PVT scintillator (standard)

Temperature range: -40 to +60 °C (-40 to +140 °F)
Influence of ambient temperature: +- 0.5%, typical long-term stability < 1%/a

PVT scintillator (high-temperature version)

- Temperature range: +5 to +60 °C (41 to +140 °F)
Influence of ambient temperature: +- 0.5%, typical long-term stability < 1%/a
- Temperature range: -20 to +80 °C (-4 to +176 °F)
Influence of ambient temperature: +- 0.5%, typical long-term stability < 3%/a

Statistical fluctuation of the radioactive decay

The radioactive decay of the radiation source is subject to statistical fluctuation. For this reason, the pulse rate displayed fluctuates around its mean value. The standard deviation σ is an indicator of the intensity of these fluctuations. It is calculated as follows:

$$\sigma = \sqrt{I} / \sqrt{\tau}$$

Where:

- I is the pulse rate
- τ is the output damping (can be selected by the user), (device parameter: damping output)

Various confidence intervals can be calculated from the standard deviation. The 2σ confidence interval is usually used for the planning of radiometric measuring systems. Approx. 95% of all pulse rates displayed deviate by less than 2σ from the mean. The deviation is greater than 2σ in only about 5% of all cases.

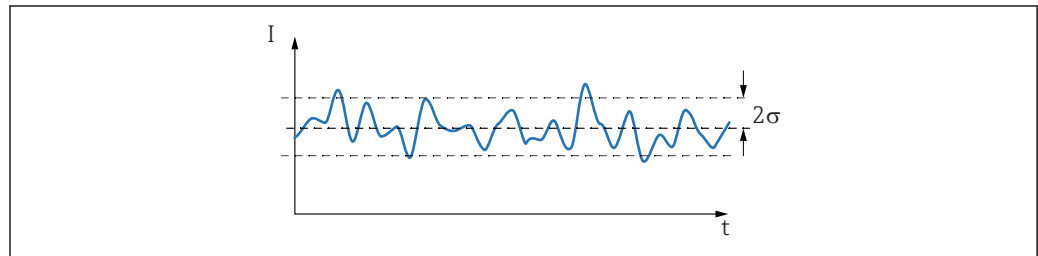

A0018258

9 95% of all measured values are within the 2σ confidence interval.

In order to calculate the relative (%) statistical measured error, the standard deviation is divided by the pulse rate:

$$2\sigma_{\text{rel}} = 2\sigma / I = 2 / \sqrt{I\tau}$$

Example:

- I = 1000/s
 - $\tau = 10$ s
- $$2\sigma_{\text{rel}} = 0.02 = 2 \%$$



As a general rule, the statistical signal fluctuation can be reduced by increasing the output damping value (device parameter: damping output) or the radiation intensity.

Installation conditions

General

- The angle of emission of the source container must be exactly aligned to the measuring range of the Gammapiilot FMG50. Observe the measuring range marks of the device.
- The source container and the Gammapiilot FMG50 should be mounted as close to the vessel as possible. Any access to the beam must be blocked to ensure that it is not possible to reach into this area.
- The Gammapiilot FMG50 should be protected against direct sunlight or process heat in order to increase its service life.
 - Feature 620, option PA: "Weather protection cover 316L"
 - Feature 620, option PV: "Heat shield 1200-3000 mm, PVT"
 - Feature 620, option PW: "Heat shield NaI, 200-800 mm, PVT"
- Terminals can optionally be ordered with the device
- The mounting device must be installed in such a way as to withstand the weight of the Gammapiilot FMG50 under all anticipated operating conditions (e.g. vibrations).

 More information with regard to the safety-related use of the Gammapiilot FMG50 can be found in the Functional Safety Manual.

Installation conditions for level measurement

Conditions

- The Gammapiilot FMG50 is mounted vertically for level measurements.
- To facilitate installation and commissioning, the Gammapiilot FMG50 can be configured and ordered with an additional support (order feature 620, option Q4: "Retaining bracket").

Examples

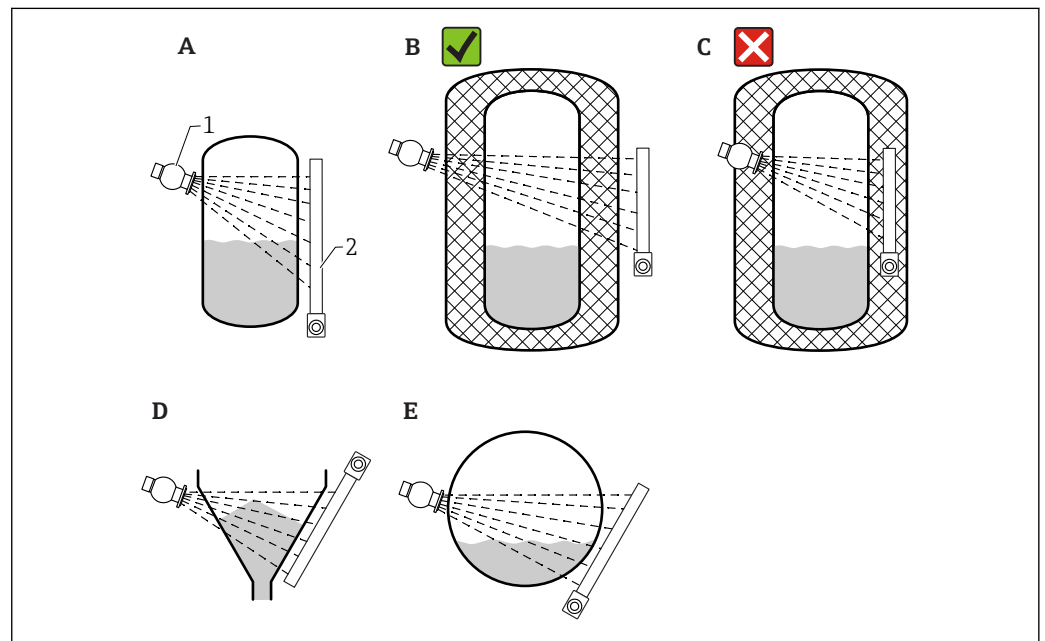

- A Vertical cylinder; the Gammapiilot FMG50 is mounted vertically with the detector head pointing either downwards or upwards, the gamma radiation is aligned to the measuring range.
- B Correct: Gammapiilot FMG50 mounted outside the tank insulation
- C Incorrect: Gammapiilot FMG50 mounted inside the tank insulation
- D Conical tank outlet
- E Horizontal cylinder
- 1 Source container
- 2 Gammapiilot FMG50

Installation conditions for point level detection

Conditions

For point level detection, the Gammapiilot FMG50 is generally mounted horizontally at the height of the desired level limit.

Measuring system arrangement

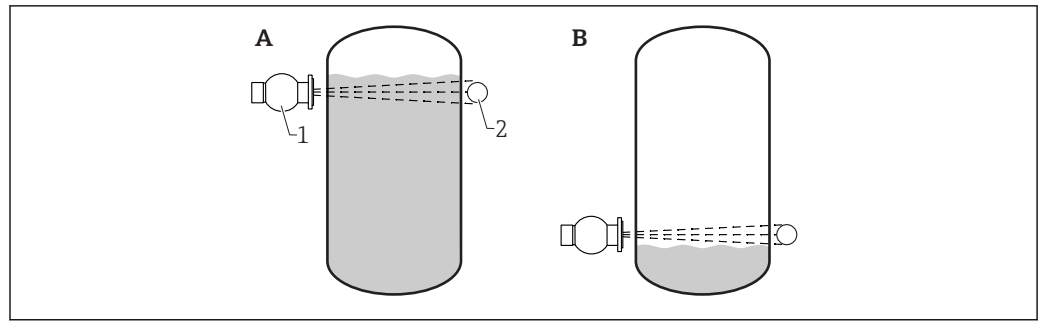

A0018075

- A Maximum point level detection
 B Minimum point level detection
 1 Source container
 2 Gammapilot FMG50

Installation conditions for density measurement

Conditions

- If possible, density should be measured on vertical pipes with forward flow from bottom to top.
- If only horizontal pipes are accessible, the path of the beam should also be arranged horizontally to minimize the influence of air bubbles and deposits.
- The Endress+Hauser clamping device or an equivalent clamping device should be used to fasten the source container and the Gammapilot FMG50 to the measuring pipe.
The clamping device itself must be installed in such a way as to withstand the weight of the source container and the Gammapilot FMG50 under all anticipated operating conditions.
- The sample point may not be further than 20 m (66 ft) from the measuring point.
- The distance of the density measurement to pipe bends is ≥ 3 x pipe diameter, and ≥ 10 x pipe diameter in the case of pumps.

Measuring system arrangement

The arrangement of the source container and the Gammapilot FMG50 depends on the pipe diameter (or the radiated length) and the density measuring range. These two parameters determine the measuring effect (relative change in the pulse rate). The longer the radiated length, the greater the measuring effect. Therefore, it is advisable to use diagonal irradiation or a measuring path for small pipe diameters.

To select the measuring system arrangement please contact the Endress+Hauser sales organization or use the Applicator™ configuration software. ²⁾

2) The Applicator™ is available from your Endress+Hauser sales organization.

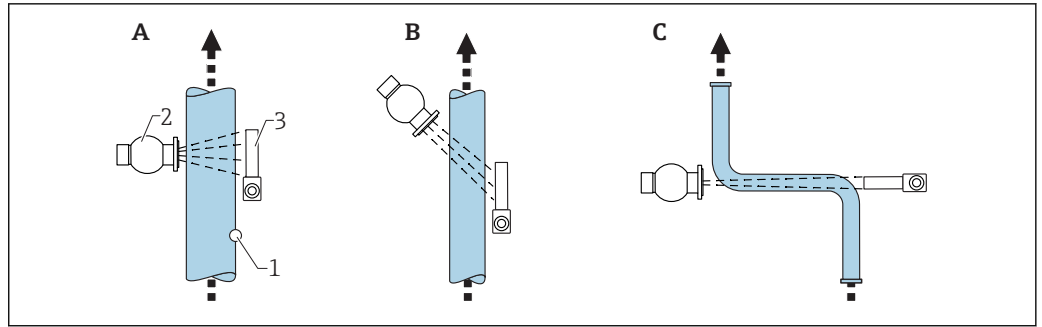

A0018076

- A Vertical beam (90°)
- B Diagonal beam (30°)
- C Measuring path
- 1 Sample point
- 2 Source container
- 3 Gammapilot FMG50

-  To increase the accuracy of density measurements, the use of a collimator is recommended. The collimator screens the detector against background radiation.
- When planning, the total weight of the measuring system must be taken into consideration.
- An FHG51 clamping device is available as an accessory

Installation conditions for interface measurement

Conditions

For interface measurement, the Gammapilot FMG50 is typically mounted horizontally at the upper or lower limit of the interface range. When introducing a radiation source into an immersion tube, it is important to ensure that the measuring range is already filled with medium in order to keep the radiation in the vicinity of the source as low as possible. When a radiation source is used in an immersion tube, the radiation can be aligned with the measuring range of the Gammapilot FMG50 using a collimator on the immersion tube.

Measuring system arrangement

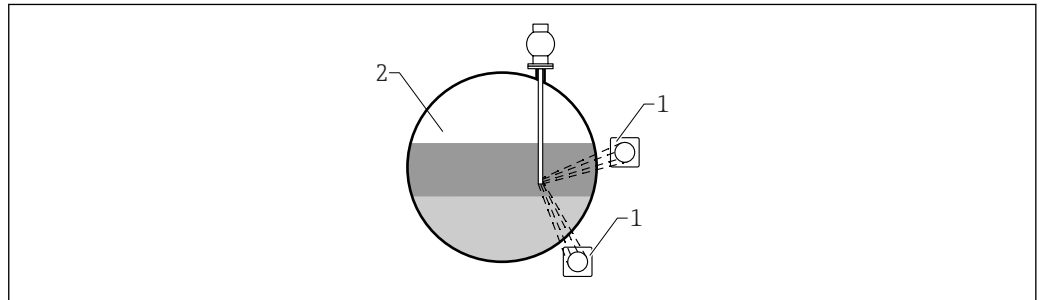

A0038167

- 1 Gammapilot (2 pcs)
- 2 Interface measurement

Description

The measuring principle is based on the fact that the radiation source emits radiation which is attenuated when it penetrates a material and the medium to be measured. In radiometric interface measurement, the radiation source is often introduced into a closed immersion tube via a cable extension. This excludes the possibility of contact between the radiation source and the medium.

Depending on the measuring range and the application, one or several detectors are mounted on the outside of the vessel. The average density of the medium between the radiation source and the detector is calculated from the radiation received. A direct correlation to the position of the interface can then be derived from this density value.

For more information, see:

 CP01205F

Installation conditions for density profile measurement (DPS)

Conditions

For density profile measurement, Gammapilot FMG50 devices are installed horizontally at defined distances, depending on the size of the measuring range. In the case of density profile measurement, the radiation source is normally inserted in an immersion tube, preferably one that is double-walled, and introduced into the vessel. When introducing a radiation source into an immersion tube, it is important to ensure that the measuring range is already filled with medium in order to keep the radiation in the vicinity of the source as low as possible.

Measuring system arrangement

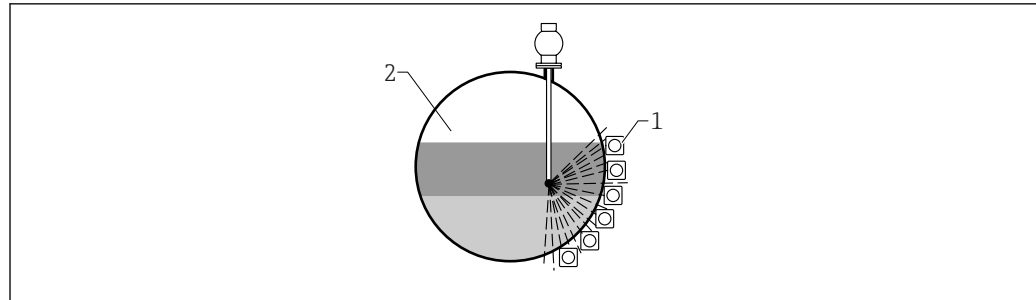

- 1 Arrangement of multiple FMG50 units
2 Density profile measurement

A0042063

Description

To obtain detailed information on the distribution of layers of different densities in a vessel, a density profile is measured using a multi-detector solution. Several FMG50 units are installed next to one another on the outside of the vessel wall for this purpose. The measuring range is divided into zones and each compact transmitter measures the density value in its respective zone. A density profile is derived from these values.

This results in a high-resolution measurement of the distribution of medium layers (e.g. in separators)

For more information, see:



CP01205F

Installation conditions for concentration measurement

Conditions

- If possible, the concentration should be measured on vertical pipes with forward flow from bottom to top.
- If only horizontal pipes are accessible, the path of the beam should also be arranged horizontally to minimize the influence of air bubbles and deposits.
- The Endress+Hauser FHG51 clamping device or an equivalent clamping device should be used to fasten the source container and the Gammapilot FMG50 to the measuring pipe.
The clamping device itself must be installed in such a way as to withstand the weight of the source container and the Gammapilot FMG50 under all anticipated operating conditions.
- The sample point may not be further than 20 m (66 ft) from the measuring point.
- The distance of the density measurement to pipe bends is $\geq 3 \times$ pipe diameter, and $\geq 10 \times$ pipe diameter in the case of pumps.

Measuring system arrangement

The arrangement of the source container and the Gammapilot FMG50 depends on the pipe diameter (or the radiated length) and the density measuring range. These two parameters determine the measuring effect (relative change in the pulse rate). The longer the radiated length, the greater the measuring effect. Therefore, it is advisable to use diagonal irradiation or a measuring path for small pipe diameters.

To select the measuring system arrangement please contact the Endress+Hauser sales organization or use the Applicator™ configuration software. ³⁾

3) The Applicator™ is available from your Endress+Hauser sales organization.

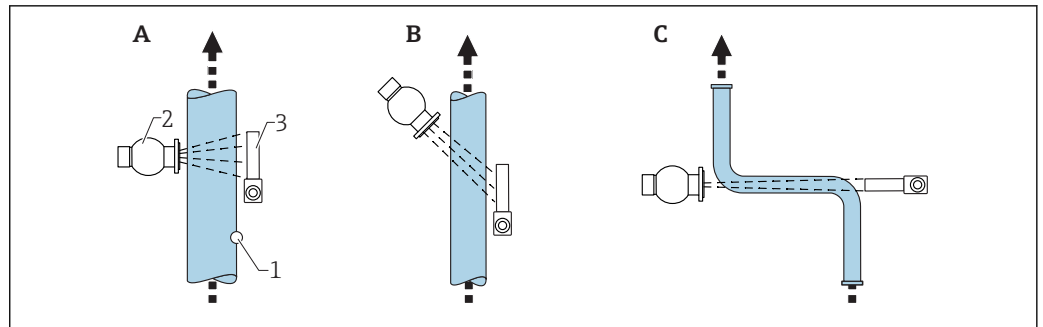

A0018076

- A Vertical beam (90°)
- B Diagonal beam (30°)
- C Measuring path
- 1 Sample point
- 2 Source container
- 3 Gammapiilot FMG50



- When planning, the total weight of the measuring system must be taken into consideration.
- An FHG51 clamping device is available as an accessory

Installation conditions for concentration measurement with radiating media

Measurement of the concentration of radiating media in vessels

The concentration of radiating media in vessels can be determined by taking a measurement at the vessel wall or in an immersion tube in the vessel. The intensity of the radiation received is proportional to the concentration of the radiating medium in the vessel. It is important to note that the medium in the vessel also absorbs its own radiation. The detected radiation will not increase further with larger diameters and the signal is saturated. This saturation length depends on the half-value layer of the material.

The level in the vessel must be constant in the vicinity of the detector to ensure the measurement is correct.

Measurement of the mass flow of radiating media

In the case of belt scales and pipes, the concentration of the radiating medium can be measured in the sample. Here, the device is mounted above or below the conveyor belt so that it is parallel to the belt direction, or is mounted on the pipe. The intensity of the radiation received is proportional to the concentration of the radiating medium in the conveyed material.

Installation conditions for flow measurement

Measurement of mass flow (liquids)

The density signal determined by the Gammapiilot FMG50 is transmitted to the Promag 55S. The Promag 55S measures the volume flow; the Promag can determine a mass flow in connection with the calculated density value.

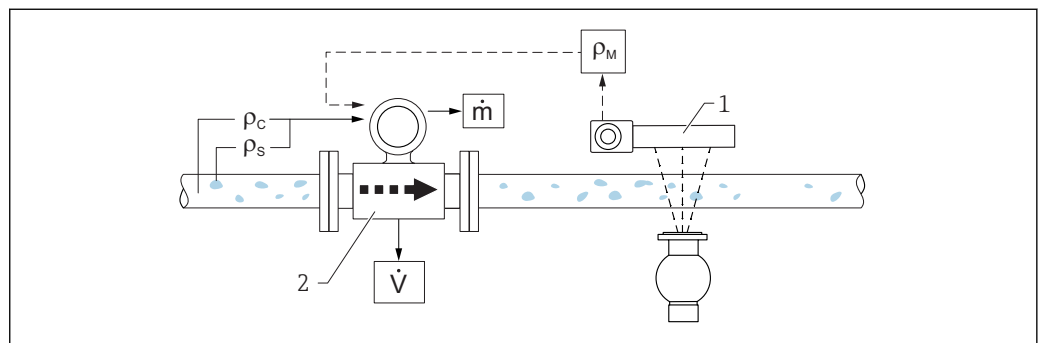

A0018093

- 10 Mass flow measurement (\dot{m}) using a density meter and a flowmeter. If the density of the solids (ρ_s) and the density of the carrier liquid (ρ_c) are also known, the solids flow rate can be calculated.

- 1 Gammapiilot FMG50 -> total density (ρ_m) consisting of the carrier liquid and solids
- 2 Flowmeter (Promag 55S) -> volume flow (\dot{V}). The solids density (ρ_s) and the density of the carrier liquid (ρ_c) also have to be entered in the transmitter

Measurement of mass flow (solids)

Bulk solids applications on conveyor belts and conveyor screws.

The source container is positioned above the conveyor belt and the Gammapilot FMG50 below the conveyor belt. The radiation is attenuated by the medium on the conveyor belt. The intensity of the radiation received is proportional to the density of the medium. The mass flow is calculated from the belt speed and the radiation intensity.

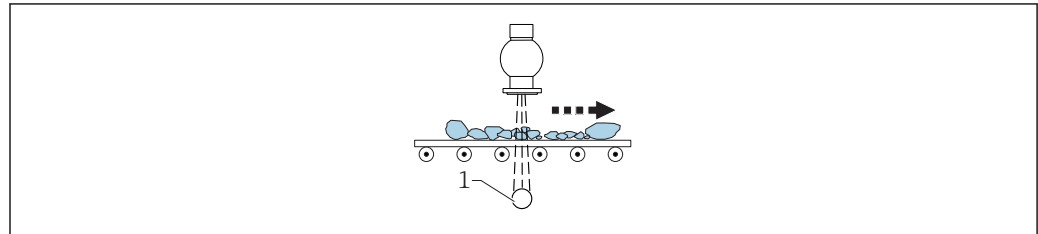

1 Gammapilot FMG50

A0036637

Environment

Ambient temperature

NaI (Tl) crystal

Ambient temperature: -40 to +80 °C (-40 to +176 °F)

PVT scintillator (standard)

Ambient temperature: -40 to +60 °C (-40 to +140 °F)

PVT scintillator (high-temperature version)

Ambient temperature: -20 to +80 °C (-4 to +176 °F)

i The temperature range may be restricted for applications in hazardous areas. Observe the maximum ambient temperature indicated in the relevant approval. Avoid exposure to direct sunlight; use a weather protection cover.

Storage temperature

NaI (Tl) crystal

-40 to +80 °C (-40 to +176 °F)

PVT scintillator (standard)

-40 to +60 °C (-40 to +140 °F)

PVT scintillator (high-temperature version)

-20 to +80 °C (-4 to +176 °F)

i As the device contains a battery, it is recommended to store the device at room temperature in a location that does not receive direct sunshine

Climate class

IEC 60068-2-38 Test Z/AD

Operating altitude as per IEC 61010-1 Edition 3.1

5 000 m (16 404 ft)

Degree of protection

- When housing is closed:
 - IP68 (at 1.83 m under water), NEMA Type 6P
 - IP66, NEMA Type 4X
- When housing is open: IP20, NEMA Type 1

i With the M12 connector, the IP68 NEMA Type 6P degree of protection only applies if the connecting cable is plugged in and is also specified to IP68 NEMA Type 6P.

The following applies if a HAN7D connector is used:

- When housing is closed and connecting cable is plugged in: IP65, NEMA Type 2
- When housing is open and/or connecting cable is not plugged in: IP20, NEMA type 1

Vibration resistance

DIN EN 60068-2-64; test Fh; 5 to 2000 Hz, 1(m/s²)²/Hz

Shock resistance IEC 60068-2-27; test Ea; 30 g, 18 ms, 3 shocks/direction/axis

Electromagnetic compatibility (EMC) Electromagnetic compatibility in accordance with all of the relevant requirements outlined in the EN 61326 series and NAMUR Recommendation EMC (NE 21). For details, please refer to the Declaration of Conformity⁴⁾.

A normal device cable suffices if only the analog signal should be used. Use a shielded cable for digital communication (HART).

Maximum measured error during EMC testing: <0.5 % of the span.

Process conditions

General

- The measuring principle generally does not depend on the process conditions
- Take radiating media into consideration
The FHG65 gamma modulator must be used for radiating media. This does not apply for concentration measurement with radiating media.

Process temperature In the event of high process temperatures, ensure sufficient insulation between the process vessel and detector (see -> "Ambient temperature"). If necessary, use the heat shield that is optionally available.

Process pressure Consider the influence of the pressure on the gas phase when calculating the necessary activity and during adjustment.

Mechanical construction

Dimensions, weights Gammapilot FMG50

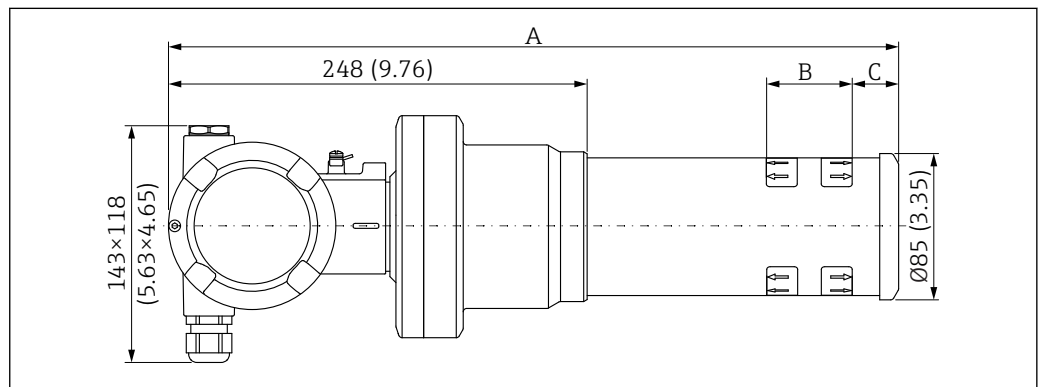

A0037984

4) Available for download at www.de.endress.com.

- **Version Nal (Tl) 2" :**
 - Total length A: 430 mm (16.93 in)
 - Total weight: 11.60 kg (25.57 lb)
 - Measuring range length B: 51 mm (2 in)
 - Distance C: 24 mm (0.94 in)
 - **Version Nal (Tl) 4" :**
 - Total length A: 480 mm (18.90 in)
 - Total weight: 12.19 kg (26.87 lb)
 - Measuring range length B: 102 mm (4 in)
 - Distance C: 24 mm (0.94 in)
 - **Version Nal (Tl) 8" :**
 - Total length A: 590 mm (23.23 in)
 - Total weight: 13.00 kg (28.63 lb)
 - Measuring range length B: 204 mm (8 in)
 - Distance C: 30 mm (1.18 in)
 - **Version PVT 200 :**
 - Total length A: 590 mm (23.23 in)
 - Total weight: 12.10 kg (26.68 lb)
 - Measuring range length B: 200 mm (8 in)
 - Distance C: 41 mm (1.61 in)
 - **Version PVT 400 :**
 - Total length A: 790 mm (31.10 in)
 - Total weight: 13.26 kg (29.23 lb)
 - Measuring range length B: 400 mm (16 in)
 - Distance C: 41 mm (1.61 in)
 - **Version PVT 800 :**
 - Total length A: 1 190 mm (46.85 in)
 - Total weight: 15.54 kg (34.26 lb)
 - Measuring range length B: 800 mm (32 in)
 - Distance C: 41 mm (1.61 in)
 - **Version PVT 1200 :**
 - Total length A: 1 590 mm (62.60 in)
 - Total weight: 17.94 kg (39.55 lb)
 - Measuring range length B: 1 200 mm (47 in)
 - Distance C: 41 mm (1.61 in)
 - **Version PVT 1600 :**
 - Total length A: 1 990 mm (78.35 in)
 - Total weight: 20.14 kg (44.40 lb)
 - Measuring range length B: 1 600 mm (63 in)
 - Distance C: 41 mm (1.61 in)
 - **Version PVT 2000 :**
 - Total length A: 2 390 mm (94.09 in)
 - Total weight: 22.44 kg (49.47 lb)
 - Measuring range length B: 2 000 mm (79 in)
 - Distance C: 41 mm (1.61 in)
 - **Version PVT 2400 :**
 - Total length A: 2 790 mm (109.84 in)
 - Total weight: 24.74 kg (54.54 lb)
 - Measuring range length B: 2 400 mm (94 in)
 - Distance C: 41 mm (1.61 in)
 - **Version PVT 3000 :**
 - Total length A: 3 390 mm (133.46 in)
 - Total weight: 28.14 kg (62.04 lb)
 - Measuring range length B: 3 000 mm (118 in)
 - Distance C: 41 mm (1.61 in)
-  The weight data refer to the stainless steel housing versions. The aluminum housing versions are 2.5 kg (5.51 lb) lighter.
-  The additional weight for small parts is: 1 kg (2.20 lb)

Materials

Two different housing versions are available for the Gammapilot FMG50.

FMG50 with stainless steel housing (HS27)

Product structure, feature 040 "Housing, material":
Option K: 316L

FMG50 with aluminum housing (HA27)

Product structure, feature 040 "Housing, material":
Option J: aluminum

Sensor housing

- Sensor housing: 316L
- Sensor housing seal: EPDM

Measuring range marks

The measuring range marks are located on the detector pipe.
They indicate the position and length of the measuring range (sensitive area).

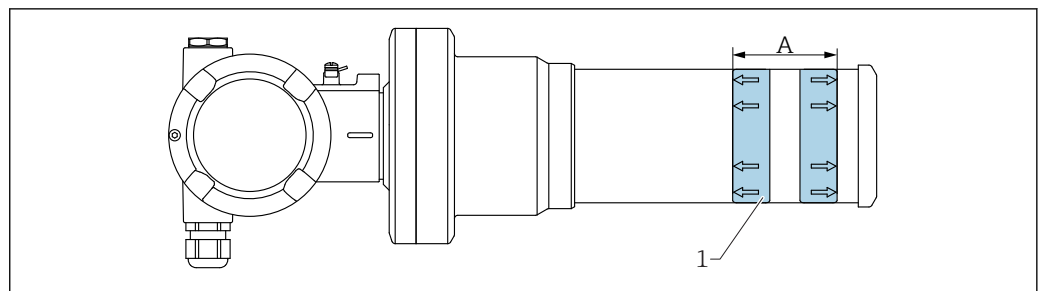

- 1 Measuring range marks
A Measuring range

A0042015

Human interface

Electronic insert / display

The electronic insert has two push buttons. Simple calibration for the level and point level can be performed via the push buttons.

Remote operation

Operation with FieldCare, DeviceCare

FieldCare and DeviceCare are Endress+Hauser asset management tools based on FDT technology. With FieldCare, you can configure all Endress+Hauser devices as well as devices from other manufacturers that support the FDT standard. Hardware and software requirements can be found on the Internet at: www.de.endress.com -> Search: FieldCare -> FieldCare -> Technical data.

FieldCare and DeviceCare support the following functions:

- Configuration of transmitters in online mode
- Loading and saving device data (upload/download)
- Documentation of the measuring point

Connection options:

- HART via Commubox FXA195 and USB interface of a computer
- Commubox FXA291 via the service interface

Operation via CDI interface

Commubox FXA291

Order number: 51516983

Connects Endress+Hauser field devices with a CDI interface (Endress+Hauser Common Data Interface) and the USB port of a computer or laptop.



DeviceCare/FieldCare via service interface (CDI)

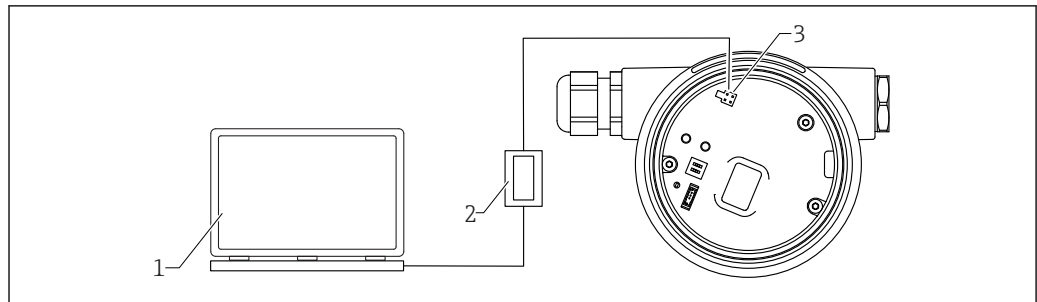

A0038834

11 DeviceCare/FieldCare via service interface (CDI)

- 1 Computer with DeviceCare/FieldCare operating tool
- 2 Commubox FXA291
- 3 Service interface (CDI) of the measuring device (= Endress+Hauser Common Data Interface)

Via Bluetooth® wireless technology (optional)

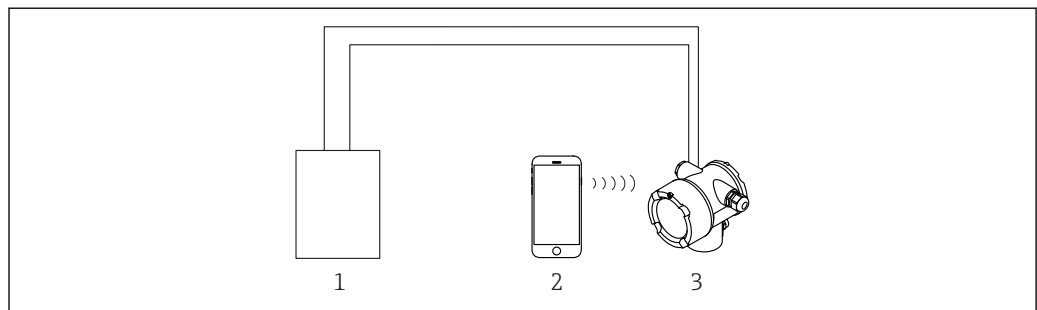

A0038833

12 Operation via SmartBlue (app)

- 1 Transmitter power supply unit
- 2 Smartphone / tablet with SmartBlue (app)
- 3 Transmitter with Bluetooth module

SmartBlue app

1. Scan the QR code or enter "SmartBlue" in the search field of the App Store.

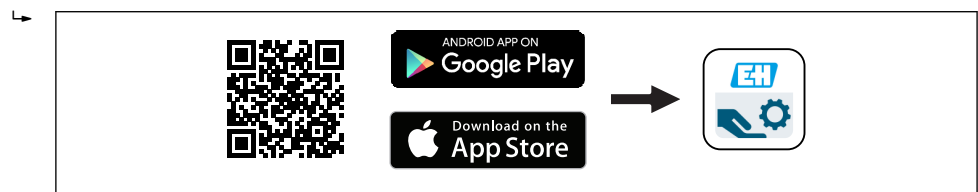

A0039186

13 Download link

2. Start SmartBlue.
3. Select device from livelist displayed.
4. Enter the login data:
 - ↳ User name: admin
 - Password: Serial number of the device or ID number of the Bluetooth display
5. Tap the icons for more information.

i After logging in for the first time, change the password!

Via HART protocol

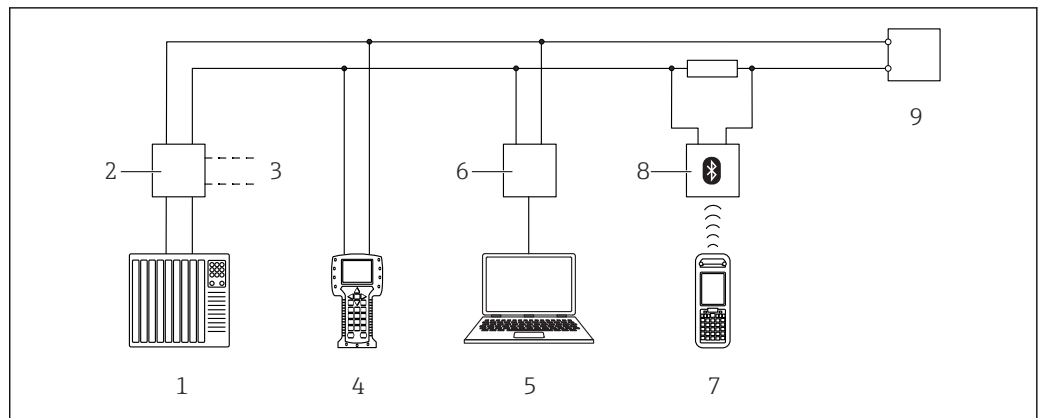

A0036169

14 Options for remote operation via HART protocol

- 1 PLC (programmable logic controller)
- 2 Transmitter power supply unit, e.g. RN221N (with communication resistor)
- 3 Connection for Commubox FXA191, FXA195 and Field Communicator 375, 475
- 4 Field Communicator 475
- 5 Computer with operating tool (e.g. DeviceCare/FieldCare, AMS Device Manager, SIMATIC PDM)
- 6 Commubox FXA191 (RS232) or FXA195 (USB)
- 7 Field Xpert SFX350/SFX370
- 8 VIATOR Bluetooth modem with connecting cable
- 9 Transmitter

Local operation

Operation with RIA15

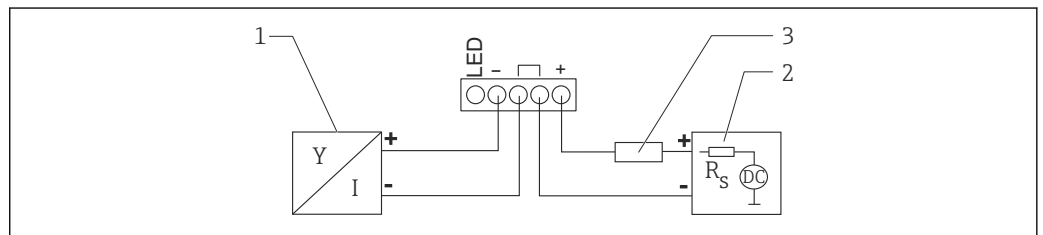

A0019567

15 Block diagram FMG50, with RIA15 process indicator

- 1 Gammapilot FMG50
- 2 Power supply
- 3 HART resistor

i The Gammapilot FMG50 can be configured for the basic setup using the RIA15 indicator

For details refer to

i TI01043K

i BA01170K

Certificates and approvals

i The availability of approvals and certificates can be called up daily via the Product Configurator.

Functional safety	SIL 2/3 according to IEC 61508, see: "Functional Safety Manual"  FY01007F
Ex approval	The Ex certificates available are listed in the ordering information. Observe the related Safety Instructions (XA) and Control Drawings (ZD). Explosion-protected smartphones and tablets Only mobile end devices with Ex approval may be used in hazardous areas.
Other standards and guidelines	<ul style="list-style-type: none"> ▪ IEC 60529 Degrees of protection provided by enclosures (IP code) ▪ IEC 61010 Safety requirements for electrical equipment for measurement, control and laboratory use ▪ IEC 61326 Interference emission (Class B equipment), interference immunity (Annex A – Industrial area) ▪ IEC 61508 Functional safety of safety-related electric/electronic/programmable electronic systems ▪ NAMUR Association for Standards for Control and Regulation in the Chemical Industry
Certificates	The certificates are available via the Product Configurator: www.us.endress.com/en/field-instruments-overview/product-finder -> Select product -> Configure
CE mark	The measuring system meets the legal requirements of the EU Directives. Endress+Hauser confirms that the device has been successfully tested by applying the CE mark.
EAC	Approval for EAC is pending
Overfill prevention	WHG for point level detection is pending

Ordering information

Ordering information	<p>Detailed ordering information is available from the following sources:</p> <ul style="list-style-type: none"> ▪ In the Product Configurator: www.us.endress.com/en/field-instruments-overview/product-finder -> Select product -> Configure ▪ From an Endress+Hauser Sales Center: www.endress.com/worldwide <p> Product Configurator - the tool for individual product configuration</p> <ul style="list-style-type: none"> ▪ Up-to-the-minute configuration data ▪ Depending on the device: Direct input of measuring point-specific information such as measuring range or operating language ▪ Automatic verification of exclusion criteria ▪ Automatic creation of the order code and its breakdown in PDF or Excel output format ▪ Ability to order directly in the Endress+Hauser Online Shop
-----------------------------	--

Application packages

Detailed description



SD02414F

SIL wizard

Availability

Available for the following versions of feature 590 "Additional approval":
LA: SIL

Function

- Wizard for the proof test which must be performed at regular intervals in the following applications:
SIL (IEC61508/IEC61511)
- To perform a proof test, the device must be locked (SIL locking).
- The wizard can be used via FieldCare, DeviceCare or a DTM-based process control system.

Heartbeat Diagnostics

Availability

Available in all device versions.

Function

- Continuous self-monitoring of the device.
- Diagnostic messages output to
 - the local display.
 - an asset management system (e.g. FieldCare/DeviceCare).
 - an automation system (e.g. PLC).

Advantages

- Device condition information is available immediately and processed in time.
- The status signals are classified in accordance with VDI/VDE 2650 and NAMUR recommendation NE 107 and contain information about the cause of the error and remedial action.

Heartbeat Verification**Availability**

Available for the following versions of feature 540 "Application package":
EH: Heartbeat Verification + Monitoring

Device functionality checked on demand

- Verification of the correct functioning of the measuring device within specifications.
- The verification result provides information about the condition of the device: **Passed** or **Failed**.
- The results are documented in a verification report.
- The automatically generated report supports the obligation to demonstrate compliance with internal and external regulations, laws and standards.
- Verification is possible without interrupting the process.

Advantages

- No onsite presence is required to use the function.
- The DTM⁵⁾ triggers verification in the device and interprets the results. No specific knowledge is required on the part of the user.
- The verification report can be used to prove quality measures to a third party.
- **Heartbeat Verification** can replace other maintenance tasks (e.g. periodic check) or extend the test intervals.

5) DTM: Device Type Manager; controls device operation via DeviceCare, FieldCare or a DTM-based process control system.

Heartbeat Monitoring

Availability

Available for the following versions of feature 540 "Application package":
EH: Heartbeat Verification + Monitoring

Function

In addition to the verification parameters, the corresponding parameter values are also logged.

Advantages

- Supports the scheduling of maintenance work, and thereby helps ensure plant availability.
- Checks the percentage measured error (standard deviation and stability) during density measurements in order to adjust the accuracy.

Accessories

Commubox FXA195 HART

For intrinsically safe HART communication with FieldCare/DeviceCare via the USB interface. For details refer to



TI00404F

Field Xpert SFX350, SFX370, SMT70

Compact, flexible and robust industrial handheld terminal for remote operation and measured value interrogation of HART devices. For details refer to



BA01202S



TI01114S

Mounting device (for level and point level measurement)

Mounting the retaining bracket

Reference dimension A is used to define the mounting location of the retaining bracket depending on the measuring range.

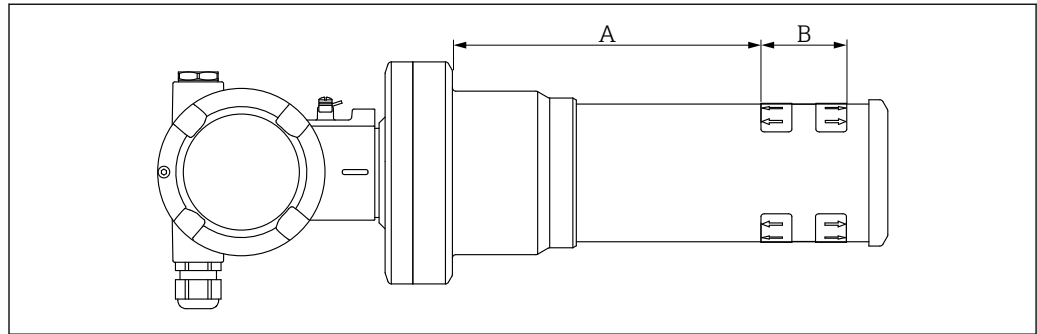

A0040283

16 A defines the distance between the device flange and the start of the measuring range. Distance A depends on the material of the scintillator (PVT or NaI).

A: PVT, distance : 172 mm (6.77 in)

A: NaI, distance : 180 mm (7.09 in)

B: Position and length of the measuring range

Mounting instructions

i Keep the distance between the mounting clamps as large as possible

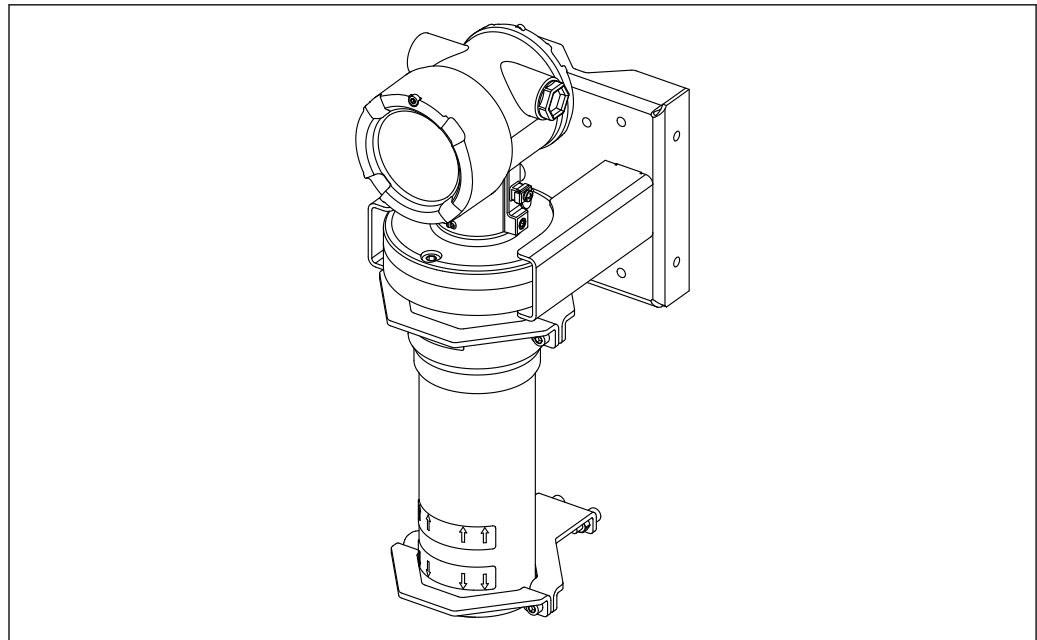

A0039103

17 Installation overview, with mounting clamps and retaining bracket

Dimensions of mounting clamps

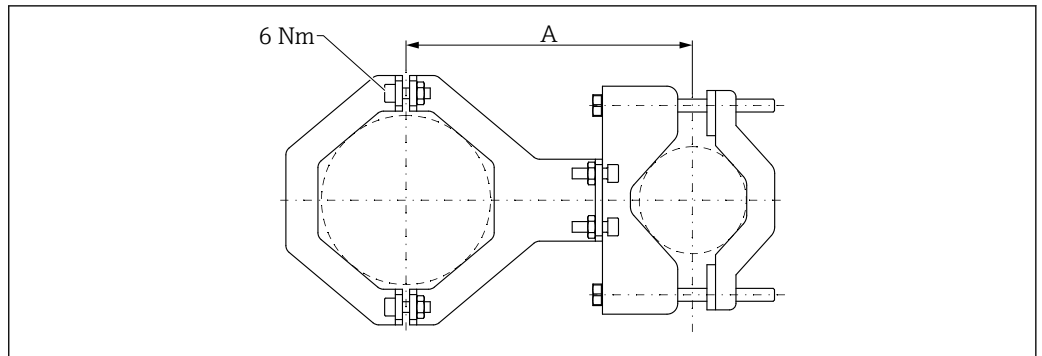

A0042084

18 Dimensions of mounting clamp

Distance A

- For electronics pipe: 210 mm (8.27 in)
- For detector pipe: 198 mm (7.8 in)

CAUTION

Max. torque for the screws of the retainers:

- ▶ 6 Nm (4.42 lbf ft)

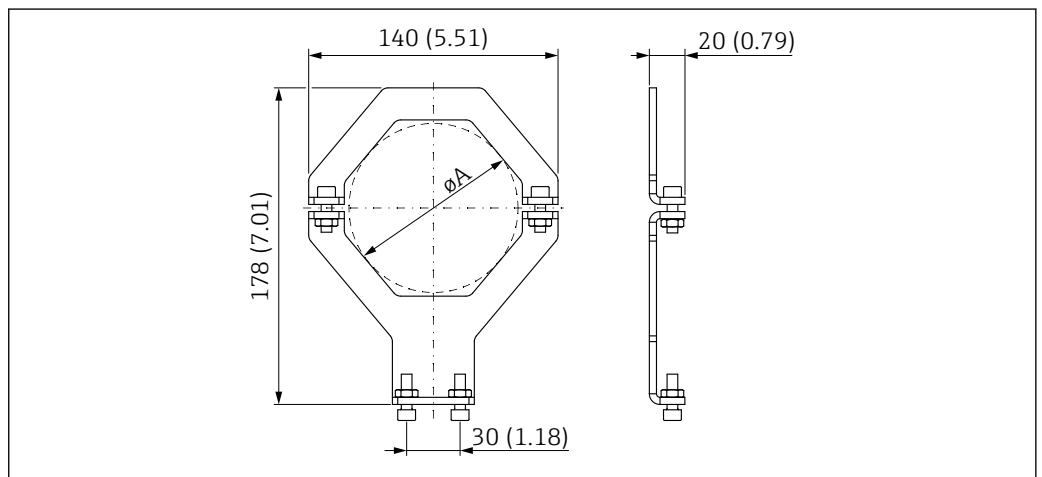

A0040029

19 Dimensions of mounting clamp

Diameter A

- Electronics pipe: 95 mm (3.74 in)
- Detector pipe: 80 mm (3.15 in)

Dimensions of pole mount

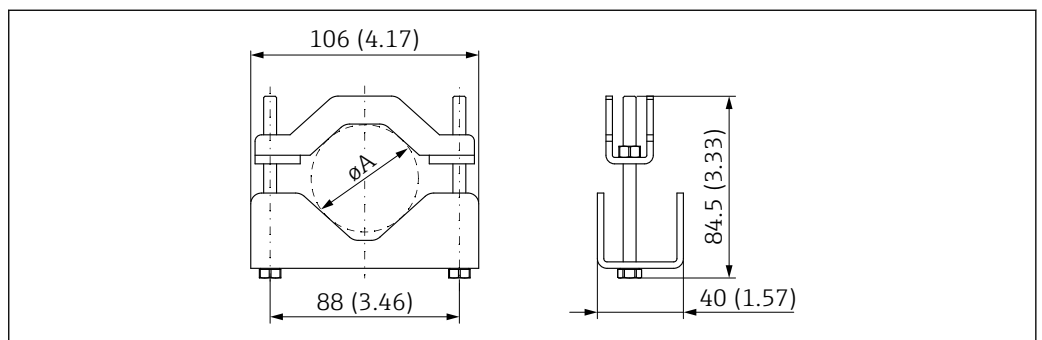

A0040266

20 ϕA : 40 to 65 mm (1.57 to 2.56 in)

Dimensions of retaining bracket

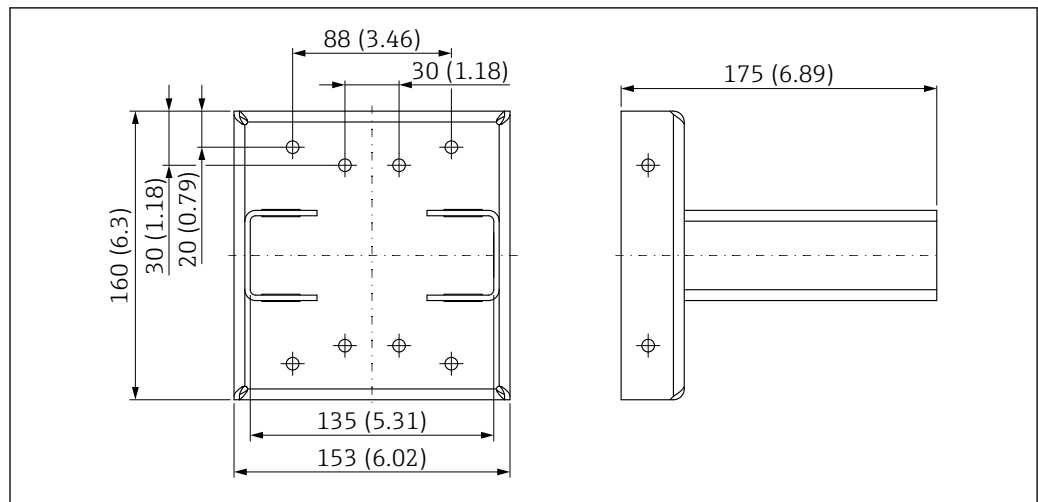

A0040030

21 Retaining bracket

Use

- ✔ Permitted
- ✘ Not recommended, observe mounting instructions

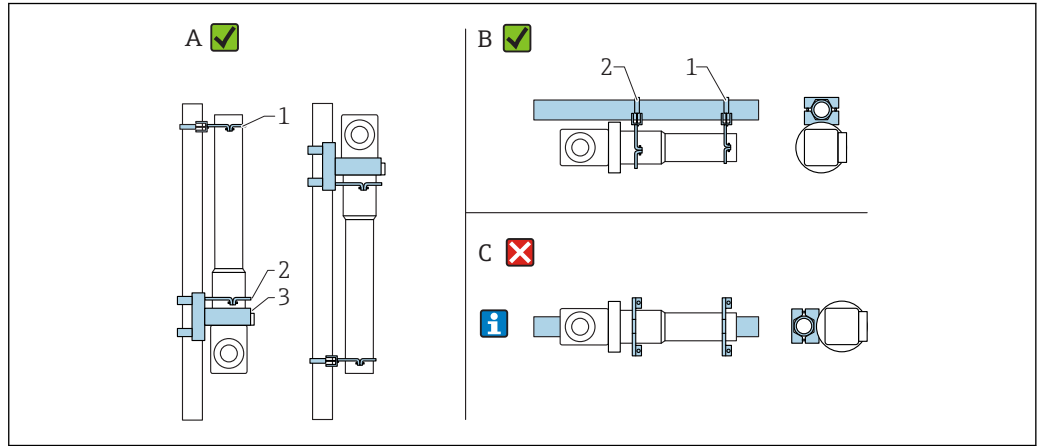

- A Level measurement, FMG50
- B Point level measurement, FMG50
- C Such horizontal mounting is not recommended
- 1 Retainer for pipe diameter 80 mm (3.15 in)
- 2 Retainer for pipe diameter 95 mm (3.74 in)
- 3 Retaining bracket

i **Mounting instructions for horizontal mounting (see Figure C):** The pipe must be mounted by the customer. It is important to ensure that the installation clamping power is sufficient to prevent the FMG50 from slipping. The dimensions are provided in the "Dimensions of the mounting clamps" section.

⚠ CAUTION

Note the following when mounting the device

- ▶ The mounting device must be installed in such a way as to withstand the weight of the Gammapilot FMG50 under all anticipated operating conditions.
- ▶ Four brackets must be used for measuring lengths of 1 600 mm (63 in) and more.
- ▶ To facilitate installation and commissioning, the Gammapilot FMG50 can be configured and ordered with an additional support (order feature 620, option Q4: "Retaining bracket").
- ▶ The customer must provide a clamping solution to mount the pipe. Do not use the enclosed mounting clamps for the pipe. The retainers provided can be used for FMG50 (see Figure C).
- ▶ To prevent damage to the detector pipe of the Gammapilot FMG50, the maximum torque that can be applied to tighten the retainer screws is 6 Nm (4.42 lbf ft).

Clamping device for density measurement FHG51

FHG51 for pipes with diameter 50 to 200 mm without protective guard

 SD02543F

FHG51 for pipes with diameter 50 to 200 mm with protective guard

 SD02533F

FHG51 for pipes with diameter 200 to 420 mm without protective guard

 SD02544F

FHG51 for pipes with diameter 200 to 420 mm with protective guard

 SD02534F

Process indicator RIA15

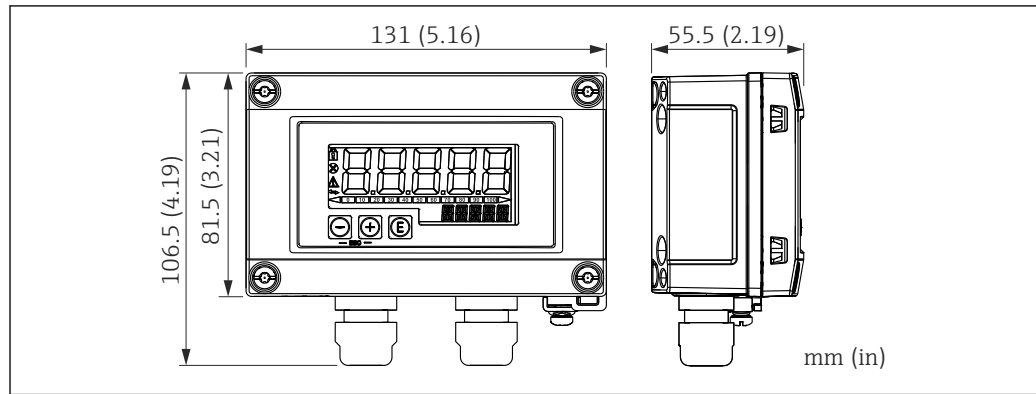

A0017722

22 Dimensions of RIA15 in field housing, engineering unit: mm (in)

i The RIA15 remote indicator can be ordered together with the device.

- Option PE "Remote indicator RIA15, non-hazardous area, aluminum field housing"
- Option PF "Remote indicator RIA15, hazardous, aluminum field housing"

Field housing material: aluminum

Other housing versions are available via the RIA15 product structure.

b Alternatively available as an accessory, for details see Technical Information TI01043K and Operating Instructions BA01170K

HART communication resistor

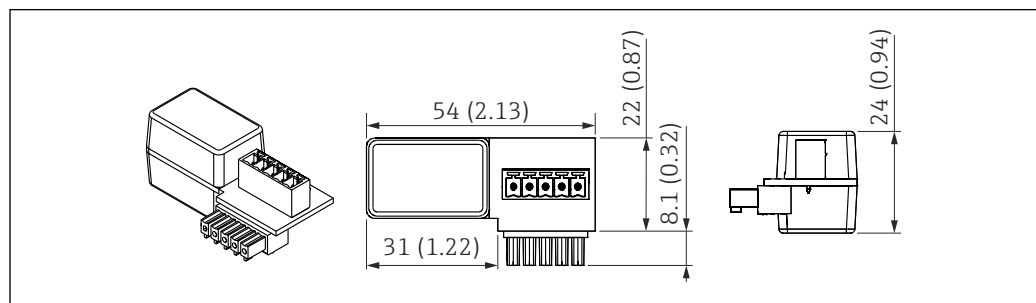

A0020858

23 Dimensions of HART communication resistor, engineering unit: mm (in)

i A communication resistor is required for HART communication. If this is not already present (e.g. in the power supply RMA42, RN221N, RNS221, ...), it can be ordered with the device via the product structure, feature 620 "Accessory enclosed": option R6 "HART communication resistor hazardous / non-hazardous area".

Supplementary documentation for Gammapilot FMG50

i For an overview of the scope of the associated Technical Documentation, refer to the following:

- *W@M Device Viewer* (www.endress.com/deviceviewer): Enter the serial number from nameplate
- *Endress+Hauser Operations App*: Enter the serial number from the nameplate or scan the 2D matrix code (QR code) on the nameplate

Fields of activity

Product overview for applications in liquids and bulk solids

b FA00001F

Operating Instructions

b BA01966F

Description of Device Functions  GP01141F

Functional safety Functional Safety Manual for Gammapilot FMG50
 FY01007F

Clamping device for density measurement  SD02533F
 SD02534F

Supplementary documentation for radiation source, source containers and modulator

Radiation source FSG60, FSG61  TI00439F

- Technical Information for radiation source FSG60/FSG61
- Returning source containers
- Type A packaging

Source container FQG60 Technical Information for source container FQG60
 TI00445F

Source container FQG61, FQG62 Technical Information for source containers FQG61 and FQG62
 TI00435F

Source container FQG61, FQG62 Technical Information for source container FQG63
 TI00446F

Source container FQG66 Technical Information for source container FQG66
 TI01171F

Operating Instructions for source container FQG66
 BA01327F

Gamma Modulator FHG65 Technical Information for Gamma Modulator FHG65 and Synchronizer FHG66
 TI00423F

Operating Instructions for Gamma Modulator FHG65 and Synchronizer FHG66
 BA00373F



www.addresses.endress.com
