

Operating Instructions

Liquiline System CA80FE

Colorimetric analyzer for iron

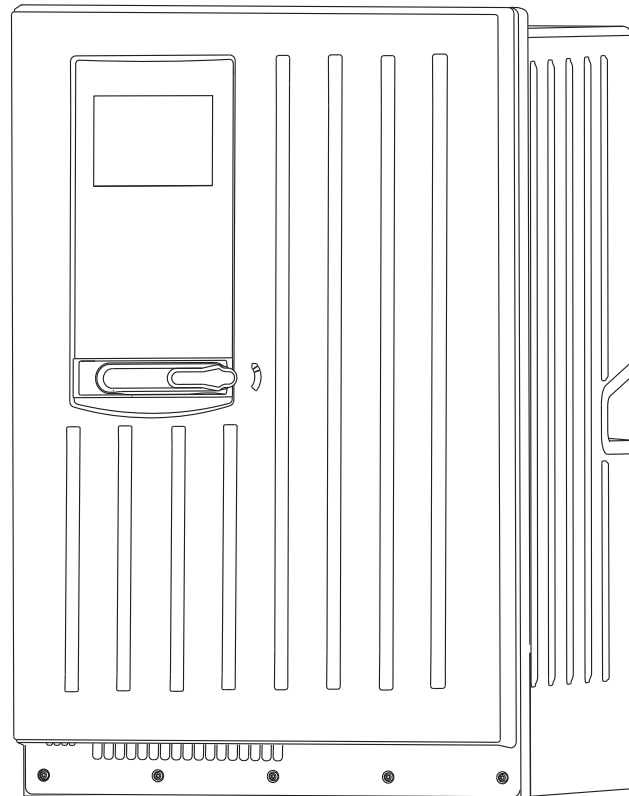





Table of contents

1	Document information	5	9	Commissioning	45
1.1	Warnings	5	9.1	Preparatory steps	45
1.2	Symbols	5	9.2	Function check	47
1.3	Symbols at the device	5	9.3	Switching ON the measuring device	48
1.4	Documentation	6	9.4	Setting the operating language	48
			9.5	Configuring the measuring device	48
2	Basic safety instructions	7	10	Operation	49
2.1	Requirements for the personnel	7	10.1	General settings	49
2.2	Designated use	7	10.2	Analyzer	61
2.3	Occupational safety	7	10.3	Sample preparation	66
2.4	Operational safety	7	10.4	Current inputs	69
2.5	Product safety	9	10.5	Binary inputs and outputs	70
			10.6	Signal outputs	79
3	Device description	10	10.7	Additional functions	87
3.1	Device design	10	11	Diagnostics and troubleshooting ..	110
3.2	Measuring system	10	11.1	General troubleshooting	110
3.3	Equipment architecture	14	11.2	Diagnostic information on local display	111
4	Incoming acceptance and product identification	16	11.3	Diagnostic information via web browser	111
4.1	Incoming acceptance	16	11.4	Diagnostic information via fieldbus	111
4.2	Product identification	16	11.5	Adapting the diagnostic information	112
4.3	Scope of delivery	17	11.6	Overview of diagnostic information	114
4.4	Certificates and approvals	17	11.7	Pending diagnostic messages	120
5	Installation	18	11.8	Diagnostics list	121
5.1	Installation conditions	18	11.9	Logbooks	121
5.2	Mounting the analyzer on a wall	20	11.10	System information	126
5.3	Mounting the analyzer on a base	22	11.11	Sensor information	128
5.4	Post-installation check	22	11.12	Simulation	128
6	Electrical connection	23	11.13	Device test	129
6.1	Connecting the analyzer	23	11.14	Resetting	131
6.2	Connecting sample preparation	25	11.15	Operating time information	131
6.3	Connecting the sensors and additional modules	28	11.16	Firmware history	132
6.4	Hardware settings	35	12	Maintenance	133
6.5	Ensuring the degree of protection	36	12.1	Maintenance schedule	133
6.6	Post-connection check	37	12.2	Cleaning	134
7	System integration	38	12.3	Replacing reagents	136
7.1	Web server	38	12.4	Carry out zero point calibration	136
7.2	Service interface	39	12.5	Replacing the hoses	137
7.3	Fieldbuses	40	12.6	Replace filter mats	138
8	Operation options	41	12.7	Replacing the dispensers	138
8.1	Overview	41	12.8	Replace liquid manager	139
8.2	Access to the operating menu via the local display	42	12.9	Decommissioning	140
8.3	Configuration options	43	13	Repair	141
			13.1	Spare parts	141
			13.2	Return	143
			13.3	Disposal	144
			14	Accessories	145
			14.1	Sample preparation	145







14.2	Consumables for CA80FE	145
14.3	Maintenance kit CAV800	145
14.4	Cleaner CY820 (for hoses of sample preparation system and of sample collecting vessel)	146
14.5	Upgrade kits CAZ800	146
14.6	Sensors	146
14.7	Additional functionality	149
14.8	Measuring cable	150
14.9	Software	151
14.10	Other accessories	151
15	Technical data	152
Index	165	

1 Document information



1.1 Warnings

Structure of information	Meaning
<p> DANGER</p> <p>Causes (/consequences) If necessary, Consequences of non-compliance (if applicable) ► Corrective action</p>	<p>This symbol alerts you to a dangerous situation. Failure to avoid the dangerous situation will result in a fatal or serious injury.</p>
<p> WARNING</p> <p>Causes (/consequences) If necessary, Consequences of non-compliance (if applicable) ► Corrective action</p>	<p>This symbol alerts you to a dangerous situation. Failure to avoid the dangerous situation can result in a fatal or serious injury.</p>
<p> CAUTION</p> <p>Causes (/consequences) If necessary, Consequences of non-compliance (if applicable) ► Corrective action</p>	<p>This symbol alerts you to a dangerous situation. Failure to avoid this situation can result in minor or more serious injuries.</p>
<p>NOTICE</p> <p>Cause/situation If necessary, Consequences of non-compliance (if applicable) ► Action/note</p>	<p>This symbol alerts you to situations which may result in damage to property.</p>

1.2 Symbols

Symbol	Meaning
	Additional information, tips
	Permitted or recommended
	Not permitted or not recommended
	Reference to device documentation
	Reference to page
	Reference to graphic
	Result of a step

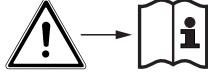
1.3 Symbols at the device

Symbol	Meaning
	Reference to device documentation
	Caution: Hazardous voltage
	Warning: Risk of injury from rotating cogwheels

1.4 Documentation

The following instructions complement these Operating Instructions and are available on the product pages on the internet:

- Brief Operating Instructions for Liquiline System CA80FE, KA01237C
- Operating Instructions for Memosens, BA01245C
 - Software description for Memosens inputs
 - Calibration of Memosens sensors
 - Sensor-specific diagnostics and troubleshooting
- Guidelines for communication via fieldbus and web server
 - PROFIBUS, SD01188C
 - Modbus, SD01189C
 - Web server, SD01190C
 - EtherNet/IP, SD01293C
- Documentation on other devices in the Liquiline platform:
 - Liquiline CM44xR (DIN rail device)
 - Liquiline System CAT8x0 (sample preparation)
 - Liquistation CSFxx (sampler)
 - Liquiport CSP44 (sampler)

2 Basic safety instructions

2.1 Requirements for the personnel

- Installation, commissioning, operation and maintenance of the measuring system may be carried out only by specially trained technical personnel.
- The technical personnel must be authorized by the plant operator to carry out the specified activities.
- The electrical connection may be performed only by an electrical technician.
- The technical personnel must have read and understood these Operating Instructions and must follow the instructions contained therein.
- Faults at the measuring point may only be rectified by authorized and specially trained personnel.

 Repairs not described in the Operating Instructions provided must be carried out only directly at the manufacturer's site or by the service organization.

2.2 Designated use

Liquiline System CA80FE is a wet-chemical analyzer for the almost continuous determination of the concentration of iron in liquid media.

The analyzer is designed for use in the following applications:

- Monitoring of the remaining iron concentration following precipitation, flocculation and filtration processes
- Monitoring of iron-rich process waters
- Quality control of raw water for the food industry

Use of the device for any purpose other than that described, poses a threat to the safety of people and of the entire measuring system and is therefore not permitted. The manufacturer is not liable for damage caused by improper or non-designated use.

2.3 Occupational safety

As the user, you are responsible for complying with the following safety conditions:

- Installation guidelines
- Local standards and regulations
- Regulations for explosion protection

Electromagnetic compatibility

- The product has been tested for electromagnetic compatibility in accordance with the applicable European standards for industrial applications.
- The electromagnetic compatibility indicated applies only to a product that has been connected in accordance with these Operating Instructions.

2.4 Operational safety

1. Before commissioning the complete measuring point, verify that all connections are correct. Ensure that electrical cables and hose connections are undamaged.
2. Do not operate damaged products, and protect them against unintentional operation. Label the damaged product as defective.
3. If faults cannot be rectified, products must be taken out of service and protected against unintentional operation.
4. Keep this door closed when not carrying out service and maintenance work.

⚠ CAUTION**Analyzer in operation and during maintenance activities**

Risk of injury and infection from medium

- ▶ Before hoses are released make sure that no action, such as the pumping of sample, is currently running or is due to start soon.
- ▶ Wear protective clothing, goggles and gloves or take other suitable measures to protect yourself.
- ▶ Wipe up any escaping reagent using a disposable cloth and rinse with clear water. Then dry the cleaned areas with a cloth.

⚠ CAUTION**Risk of injury from door stop mechanism**

- ▶ Always open the door fully to ensure the door stop engages properly.

2.5 Product safety

2.5.1 State of the art

The product is designed to meet state-of-the-art safety requirements, has been tested, and left the factory in a condition in which it is safe to operate. The relevant regulations and European standards have been observed.

Devices connected to the analyzer must comply with the applicable safety standards.

2.5.2 IT security

We only provide a warranty if the device is installed and used as described in the Operating Instructions. The device is equipped with security mechanisms to protect it against any inadvertent changes to the device settings.

IT security measures in line with operators' security standards and designed to provide additional protection for the device and device data transfer must be implemented by the operators themselves.

3 Device description

3.1 Device design

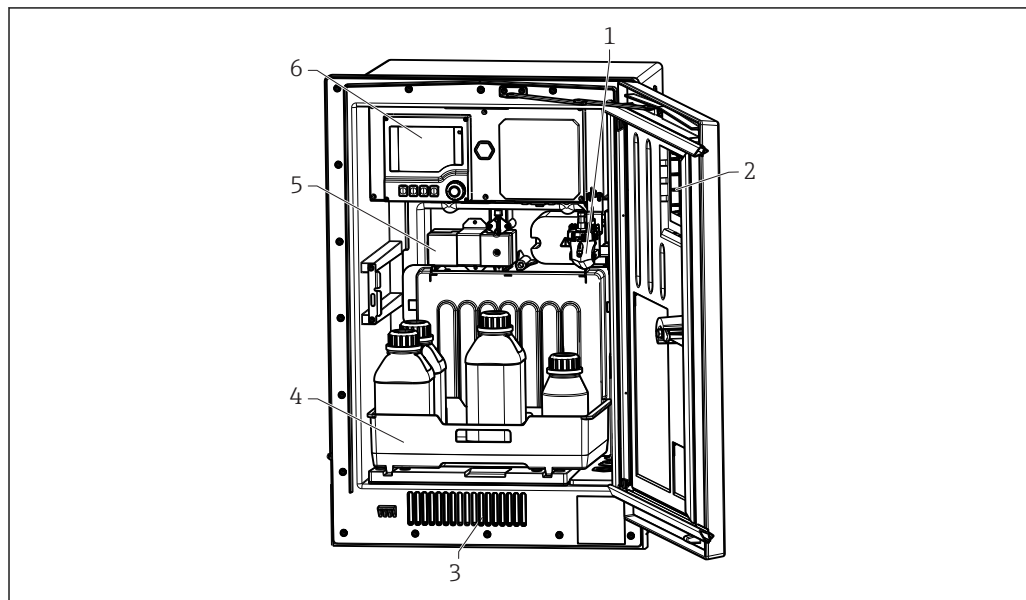

 1 Example of a Liquiline System CA80

- 1 Sample collecting vessel (optional)
- 2 Window
- 3 Air vent for cooling
- 4 Bottle tray for reagents and standard
- 5 Photometer
- 6 Controller

3.2 Measuring system

A complete measuring system comprises:

- Liquiline System CA80FE analyzer in the specified configuration
- Reagents and standard solutions (to be ordered separately)
- Liquiline System CAT8x0 sample preparation (optional)

Microfiltration (Liquiline System CAT810)

- Function: pressure pipe sampling + filtration
- Sieve filter, 50 μm
- Control via CA80
 - Optional: time control via integrated timer
- Backflushing, with compressed air or water
- Panel version or integration into analyzer stand
- Application: drinking water, industrial wastewater

Membrane filtration (Liquiline System CAT820), ceramic filter version

- Function: sampling + filtration
- Ceramic membrane filter cartridge; pore size 0.1 μm
- Communication via Memosens protocol, control via CA80
- Backflushing with compressed air (version with Memosens technology)
- Easy installation with Flexdip CYH112 (TI00430C)
- Application: sludge activation, drinking water, industrial wastewater, surface water

Membrane filtration (Liquiline System CAT860)

- Function: sampling + filtration
- Ceramic membrane filter cartridge; pore size 0.1 µm
- Communication via Memosens protocol, control via CA80
- Automatic backflush function with cleaning solution and compressed air
- Easy installation with FlexdipCYH112 (TI00430C)
- Application: wastewater treatment plant inlet

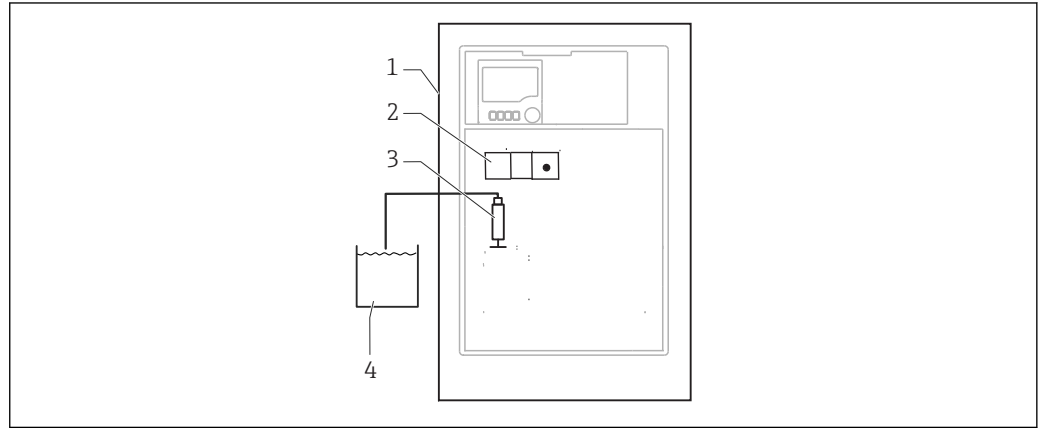

A0028796

2 Measuring system with Liquiline System, self-priming

- 1 Liquiline System CA80FE
- 2 Photometer
- 3 Dosing dispenser
- 4 Particle-free sample

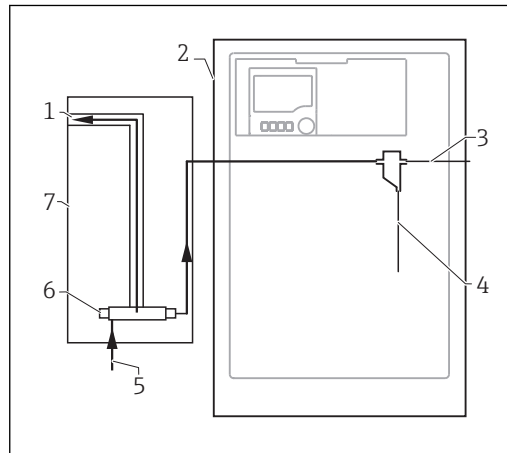

A0028792

3 Measuring system with Liquiline System CAT810

- 1 Overflow
- 2 Liquiline System CA80
- 3 Sample collecting vessel overflow
- 4 Sample
- 5 Pressurized sample
- 6 Filter unit
- 7 Liquiline System CAT810

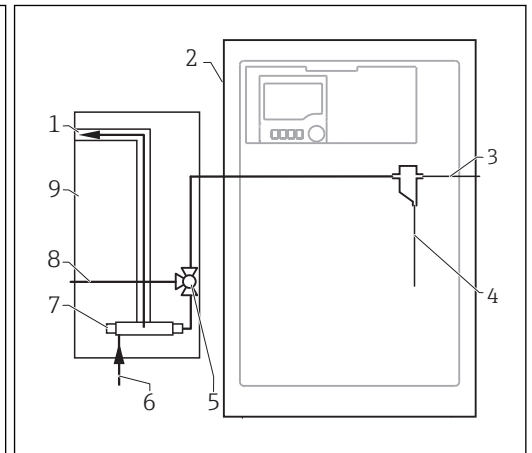

A0028793

4 Measuring system with Liquiline System CAT810 and cleaning valve

- 1 Overflow
- 2 Liquiline System CA80
- 3 Sample collecting vessel overflow
- 4 Sample
- 5 Cleaning valve
- 6 Pressurized sample
- 7 Filter unit
- 8 Purge connection (compressed air or water)
- 9 Liquiline System CAT810

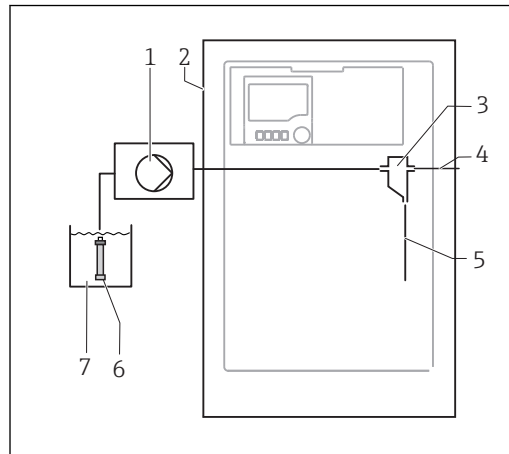

A0028789

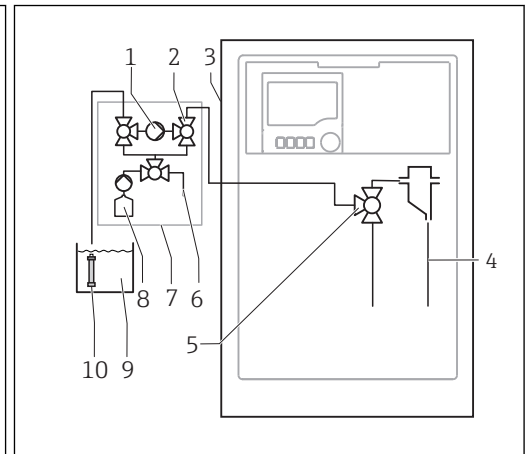

A0028788

5 Measuring system with Liquiline System CAT820

- 1 Pump
- 2 Liquiline System CA80
- 3 Sample collecting vessel
- 4 Sample collecting vessel overflow
- 5 Sample
- 6 Filter (ceramic)
- 7 Medium

6 Measuring system with Liquiline System CAT860

- 1 Pump
- 2 Valve
- 3 Liquiline System CA80
- 4 Sample
- 5 Valve
- 6 Compressed air
- 7 Liquiline System CAT860
- 8 Cleaning solution
- 9 Medium
- 10 Filter (ceramic)

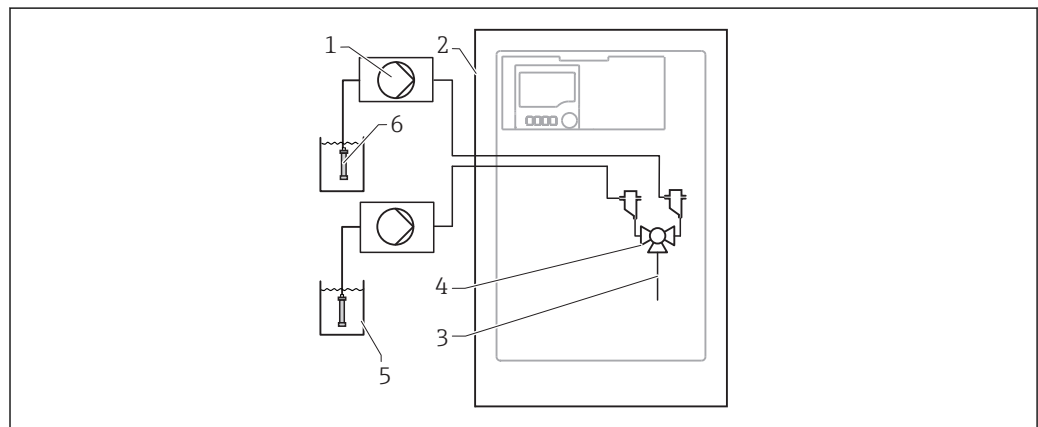

A0028790

7 Measuring system with two Liquiline Systems CAT820

- 1 Pump
- 2 Liquiline System CA80
- 3 Sample
- 4 Valve
- 5 Medium
- 6 Filter (ceramic)

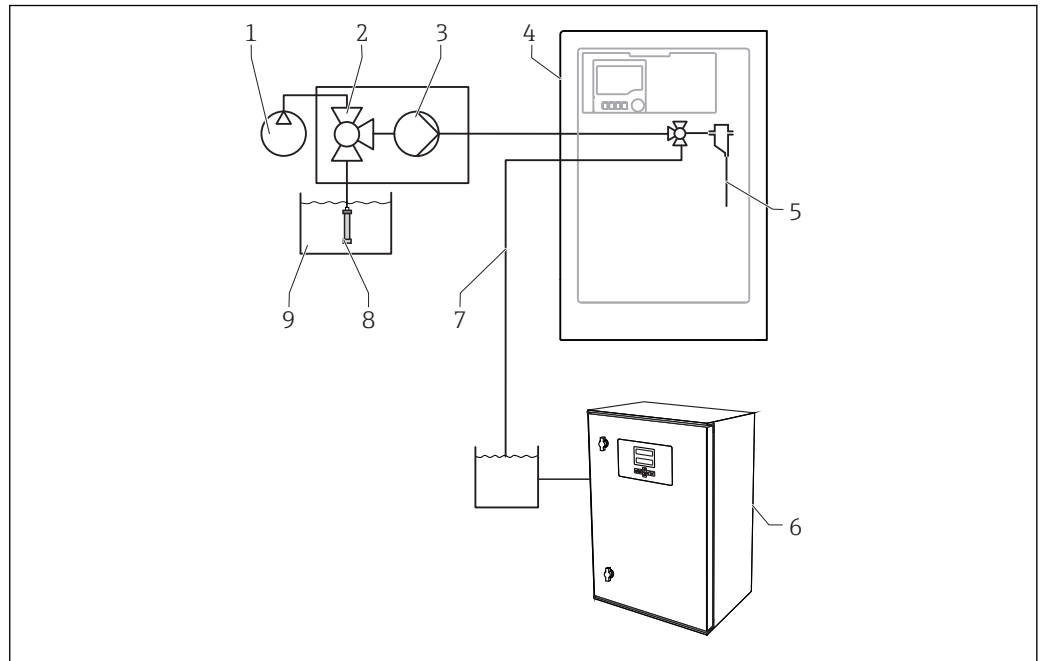

A0028787

- 8 *Measuring system with Liquiline System CA80, Liquiline System CAT820 and second analyzer*
- | | | | |
|---|--|---|----------------------------------|
| 1 | <i>Backflushing with compressed air (optional)</i> | 6 | <i>Second analyzer</i> |
| 2 | <i>Valve (optional)</i> | 7 | <i>Sample to second analyzer</i> |
| 3 | <i>Pump</i> | 8 | <i>Filter (ceramic)</i> |
| 4 | <i>Liquiline System CA80</i> | 9 | <i>Medium</i> |
| 5 | <i>Sample</i> | | |

3.3 Equipment architecture

3.3.1 Slot and port assignment

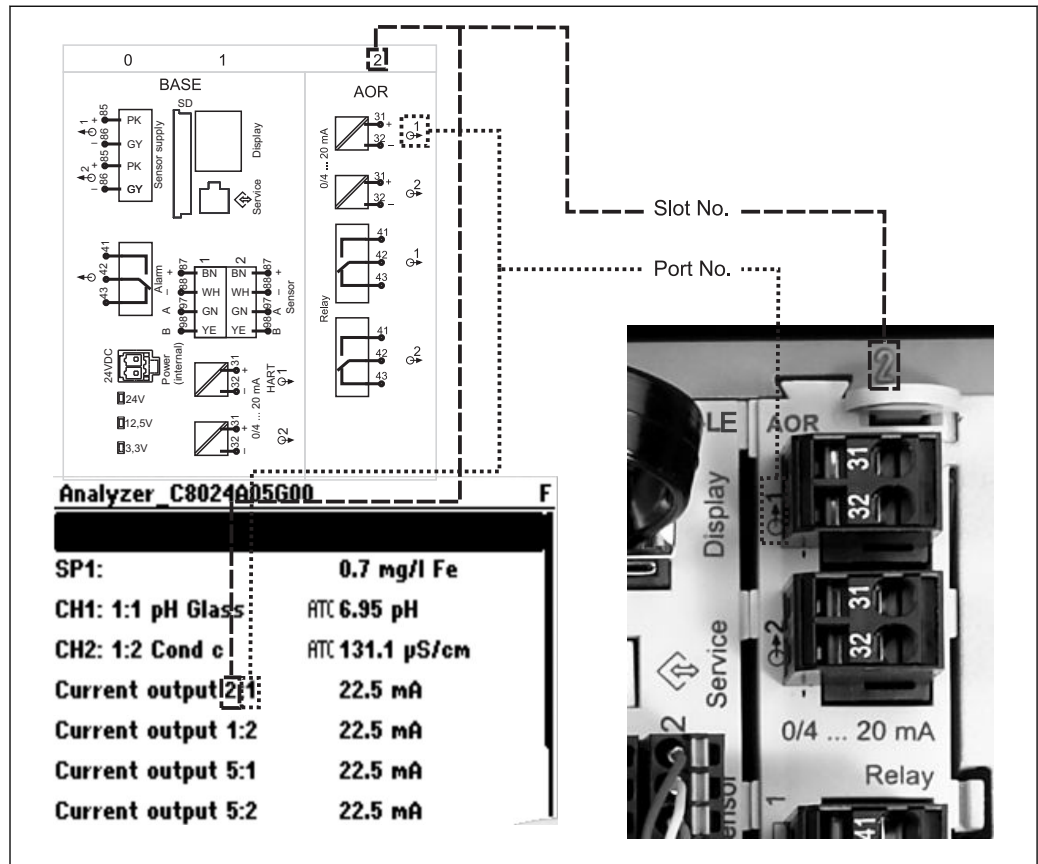

A003948-EN

The electronics configuration follows a modular concept:

- There are several slots for electronics modules. These are referred to as "slots".
- These slots are numbered consecutively in the housing. Slots 0 and 1 are always reserved for the basic module.
- Each electronics module has one or more inputs and outputs or relays. Here they are all collectively known as "ports".
- Ports are consecutively numbered per electronics module and are recognized automatically by the software.
- Outputs and relays are named according to their function, e.g. "current output", and are displayed with the slot and port numbers in ascending order.

Example:

"Current output 2:1" shown on the display means: slot 2 (e.g. AOR module) : port 1 (current output 1 of the AOR module)

- Inputs are assigned to measuring channels in the ascending order of "slot:port number"

Example:

– "SP1: **Iron**" shown on the display means:

Sampling point SP1 is assigned to analyzer measuring channel 1.

– "CH1: 1:1 pH glass" shown on the display for sensors means:

Channel 1 (CH1) is slot 1 (basic module) : port 1 (input 1) and a pH glass sensor is connected here.

3.3.2 Terminal diagram

i The unique terminal name is derived from:

Slot no. : Port no. : Terminal

Example, NO contact of a relay

Device with 4 inputs for digital sensors, 4 current outputs and 4 relays

- Base module BASE-E (contains 2 sensor inputs, 2 current outputs)
- 2DS module (2 sensor inputs)
- 2AO module (2 current outputs)
- 4R module (4 relays)

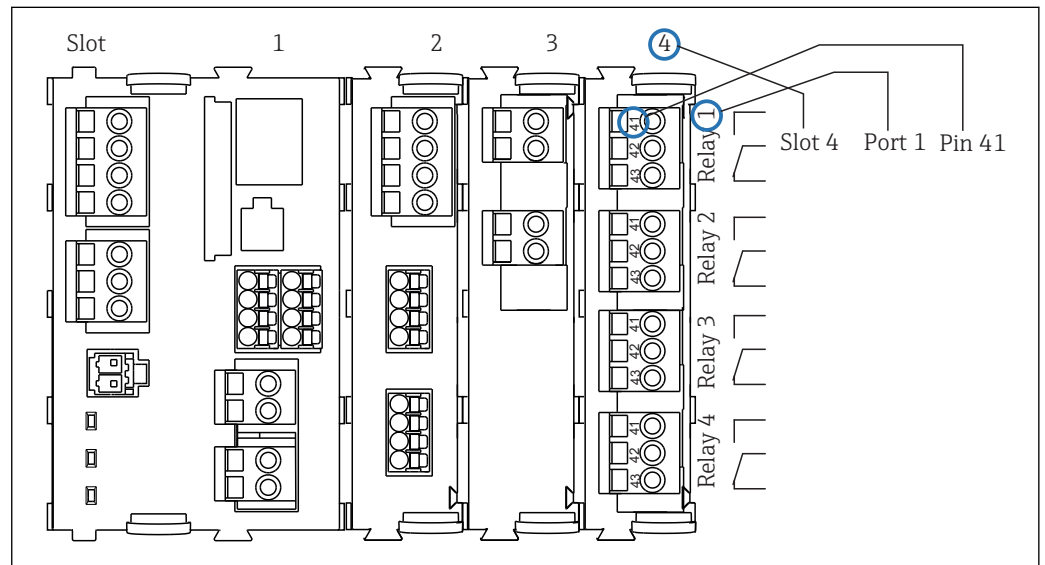

A0025105

9 Creating a terminal diagram using the example of the NO contact (terminal 41) of a relay

4 Incoming acceptance and product identification

4.1 Incoming acceptance

1. Verify that the packaging is undamaged.
 - ↳ Notify your supplier of any damage to the packaging.
Keep the damaged packaging until the matter has been settled.
2. Verify that the contents are undamaged.
 - ↳ Notify your supplier of any damage to the delivery contents.
Keep the damaged products until the matter has been settled.
3. Check the delivery for completeness.
 - ↳ Check it against the delivery papers and your order.
4. Pack the product for storage and transportation in such a way that it is protected against impact and moisture.
 - ↳ The original packaging offers the best protection.
The permitted ambient conditions must be observed (see "Technical data").

If you have any questions, please contact your supplier or your local sales center.

NOTICE

Incorrect transportation can damage the analyzer

- ▶ Always use a lifting truck or a fork-lift to transport the analyzer.

4.2 Product identification

4.2.1 Nameplate

Nameplates can be found:

- On the inside of the door on the bottom right, or on the front in the bottom right-hand corner
- On the packaging (adhesive label, portrait format)

The nameplate provides you with the following information on your device:

- Manufacturer identification
- Order code
- Extended order code
- Serial number
- Firmware version
- Ambient and process conditions
- Input and output values
- Measuring range
- Activation codes
- Safety information and warnings
- Certificate information
- Approvals as per version ordered

- ▶ Compare the data on the nameplate with your order.

4.2.2 Manufacturer address

Endress+Hauser Conducta GmbH+Co. KG
Dieselstraße 24
D-70839 Gerlingen

4.3 Scope of delivery

The scope of delivery comprises:

- 1 analyzer in the version ordered with optional hardware
- 1 print version of Brief Operating Instructions in the language ordered
- 1 Maintenance Manual
- Optional accessories

If you have any questions, please contact your supplier or local sales center.

4.4 Certificates and approvals

4.4.1 CE mark

The product meets the requirements of the harmonized European standards. As such, it complies with the legal specifications of the EU directives. The manufacturer confirms successful testing of the product by affixing to it the **CE** mark.

4.4.2 EAC

The product has been certified according to guidelines TP TC 004/2011 and TP TC 020/2011 which apply in the European Economic Area (EEA). The EAC conformity mark is affixed to the product.

4.4.3 cCSAus

The product meets the requirements as per "CLASS 2252 06 - Process Control Equipment" and "CLASS 2252 86 - Process Control Equipment". It is tested to Canada and USA standards: CAN/CSA-C22.2 No. 61010-1-12 UL Std. No. 61010-1 (3rd Edition).

5 Installation

⚠ CAUTION

Incorrect transportation or installation can cause injury and damage the device

- ▶ Always use a lifting truck or a fork-lift to transport the analyzer. Two people are needed for the installation.
- ▶ Lift the device by the recessed grips.
- ▶ In the case of the version with the analyzer stand, make sure that the housing is fixed to the floor.
- ▶ Check that the analyzer is fully hooked into the wall holder unit at the top and bottom and secure it to the upper wall holder unit using the securing screw.

5.1 Installation conditions

5.1.1 Installation options

The analyzer can be mounted in three different ways:

- As an independent table-top device
- Mounted on a wall
- Mounted on a base

5.1.2 Dimensions

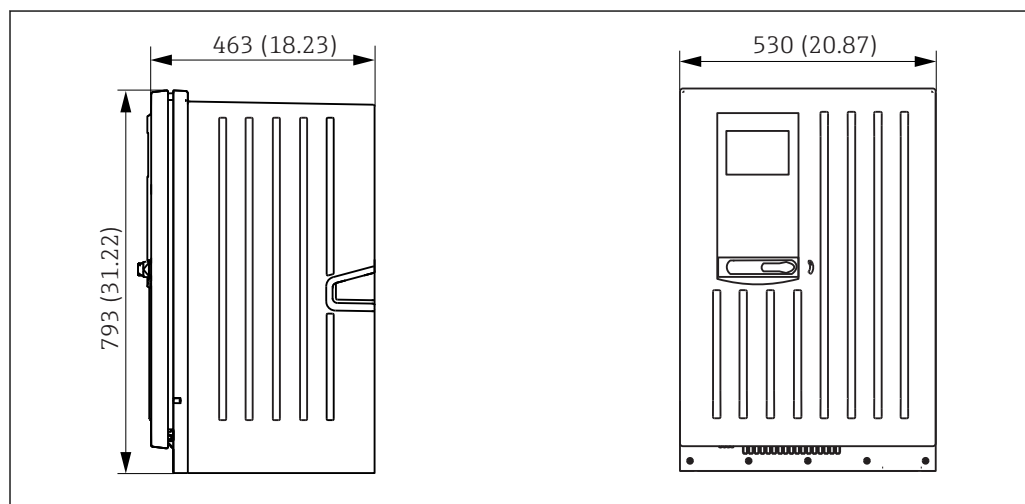

10 Liquiline System CA80 closed version, dimensions in mm (in)

A0028820

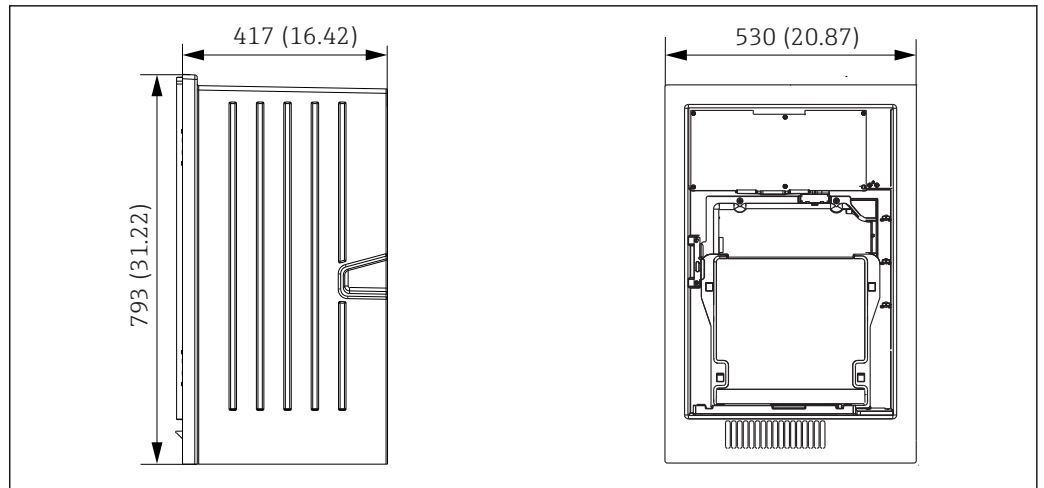

A0030419

11 *Liquiline System CA80 open version, dimensions in mm (in)*

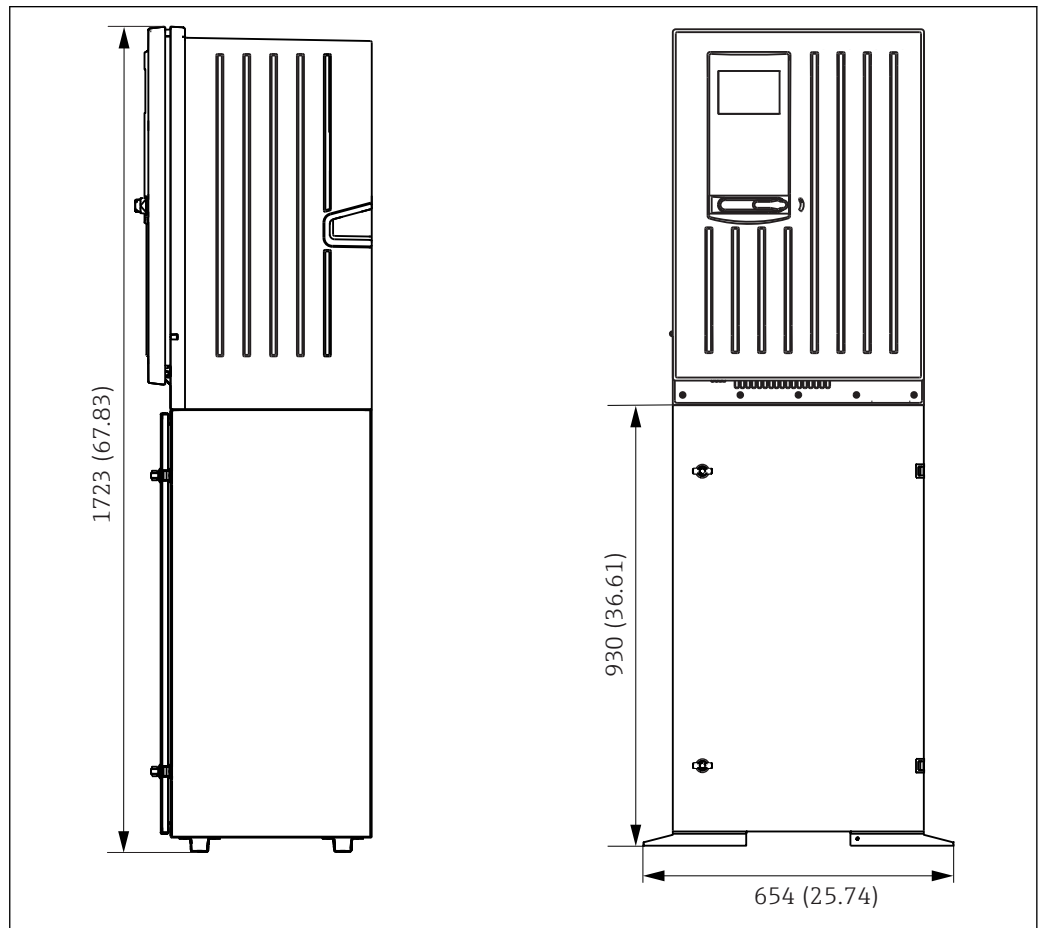

A0028821

12 *Liquiline System CA80 with base, dimensions in mm (in)*

5.1.3 Installation site

Note the following when erecting the device:

- Make sure that the wall has sufficient load-bearing capacity and is fully perpendicular.
- Mount the device on a level surface (with additional base).
- Protect the device against additional heating (e.g. from heaters).
- Protect the device against mechanical vibrations.
- Protect the device against corrosive gases, e.g. hydrogen sulfide (H₂S).

- Make sure that the fluid can drain freely without any siphoning effects.
- Make sure air can circulate freely on the front of the housing.
- Make sure that analyzers which are delivered as open analyzers (i.e. analyzers without a door) are only set up in closed areas or are installed in a protective cabinet or similar facility.

5.2 Mounting the analyzer on a wall

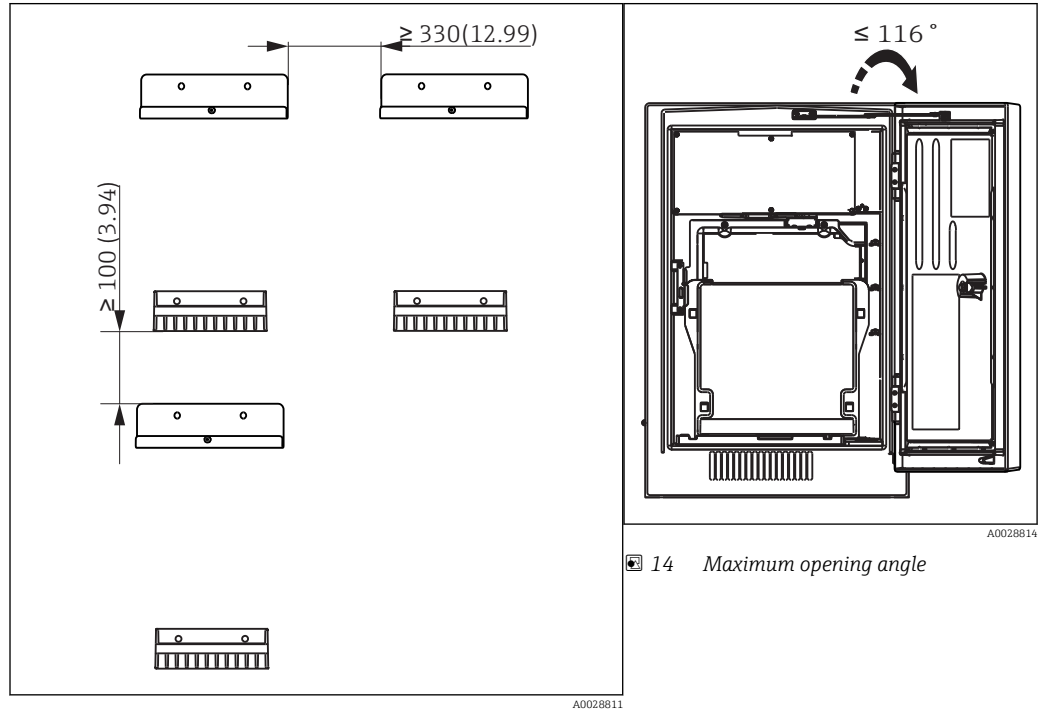

13 Minimum spacing required for mounting. Engineering unit mm (in).

- i** Mounting materials for securing the device to the wall (screws, wall plugs) are not included in the delivery and must be provided by the client.

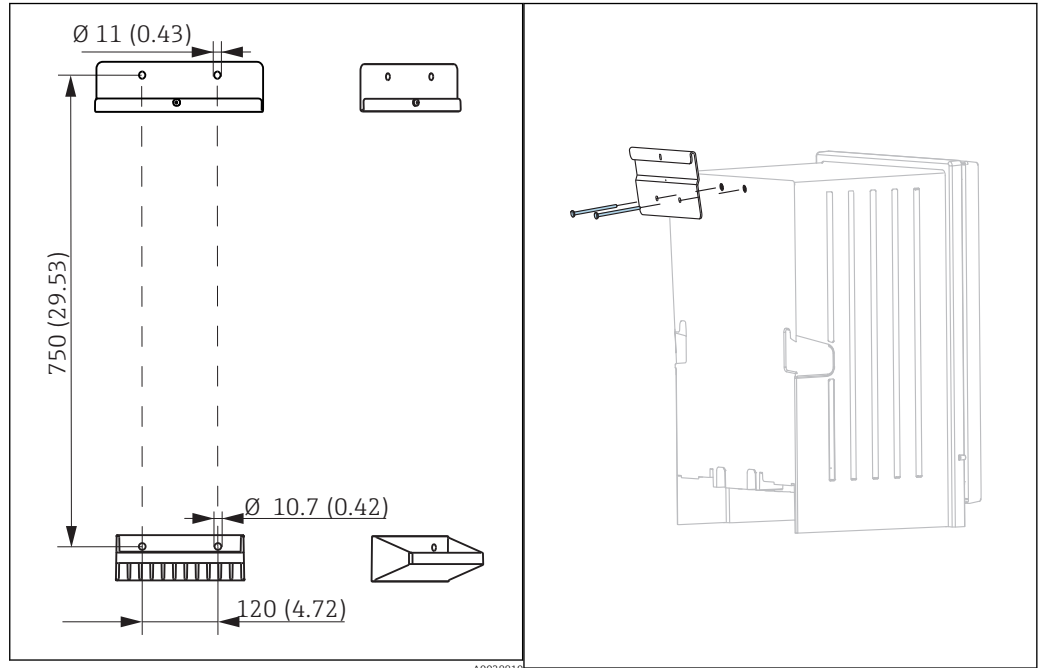

15 Holder unit dimensions. Engineering unit mm (inch) 16 Securing the holder unit on the housing

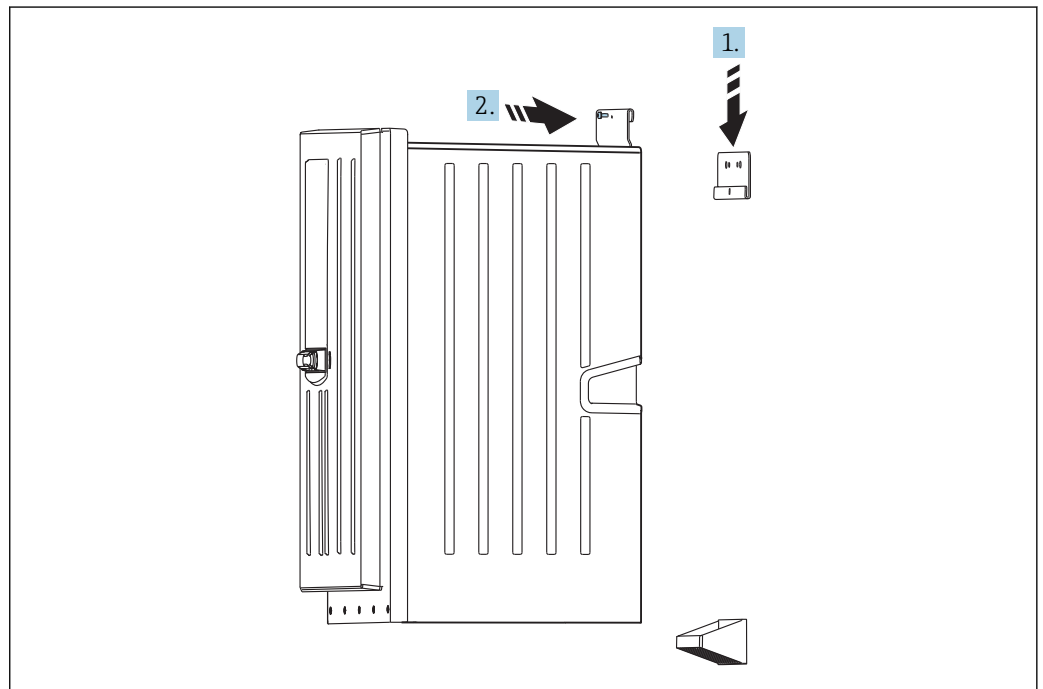

17 Hooking into the wall holder unit

1. Hook the analyzer into the wall holder unit.
2. Secure the two top parts of the wall holder unit with the screw supplied.

5.3 Mounting the analyzer on a base

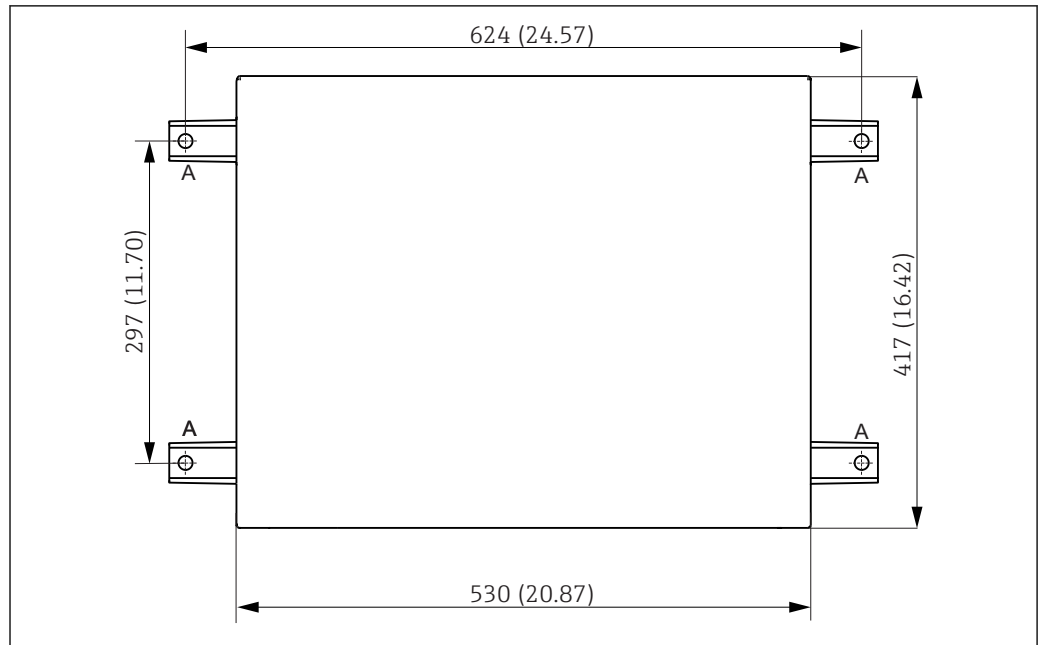

A0028809

 18 Foundation plan

A Fasteners (4 x M10)

--- Dimensions of Liquiline System CA80

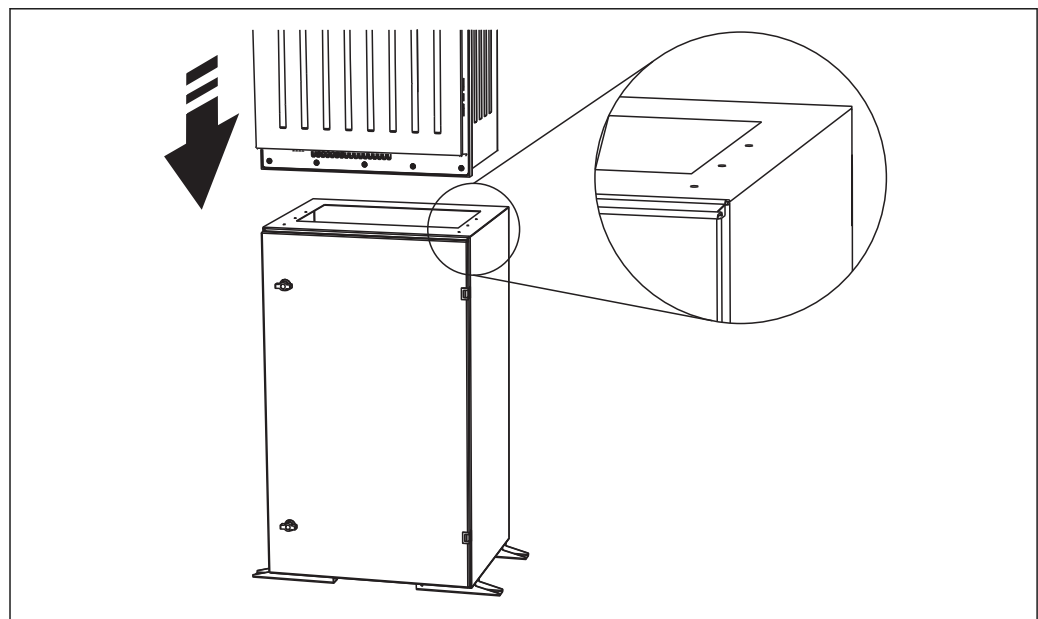

A0028817

 19 Securing the base

1. Screw the base to the ground.
2. Have two people lift the analyzer and place it on the base. Use the recessed grips.
3. Screw the base to the analyzer using the 6 screws supplied.

5.4 Post-installation check

After mounting, check all the connections to ensure they are secure.

6 Electrical connection

⚠ WARNING

Device is live

Incorrect connection may result in injury or death

- ▶ The electrical connection may be performed only by an electrical technician.
- ▶ The electrical technician must have read and understood these Operating Instructions and must follow the instructions contained therein.
- ▶ **Prior** to commencing connection work, ensure that no voltage is present on any cable.
- ▶ Before establishing the electrical connection, verify that the pre-installed power cable meets the local national electrical safety specifications.

6.1 Connecting the analyzer

NOTICE

The device does not have a power switch

- ▶ You must install the device near (distance < 3 m (10 ft)) an easily accessible and fused plug socket so that it can be disconnected from the power supply.

i Compliance with the protective grounding specifications is mandatory when installing the device.

6.1.1 Cable types

Analog, signal and transmission cables: e.g. LiYY 10 x 0.34 mm²

6.1.2 Routing the cables

1. Remove all liquid-bearing suction lines from the liquid manager.
2. Remove the bottle tray (1) by lifting up the recessed grip slightly and then pulling it towards the front.
3. Remove the cover (2) that is hooked into place.

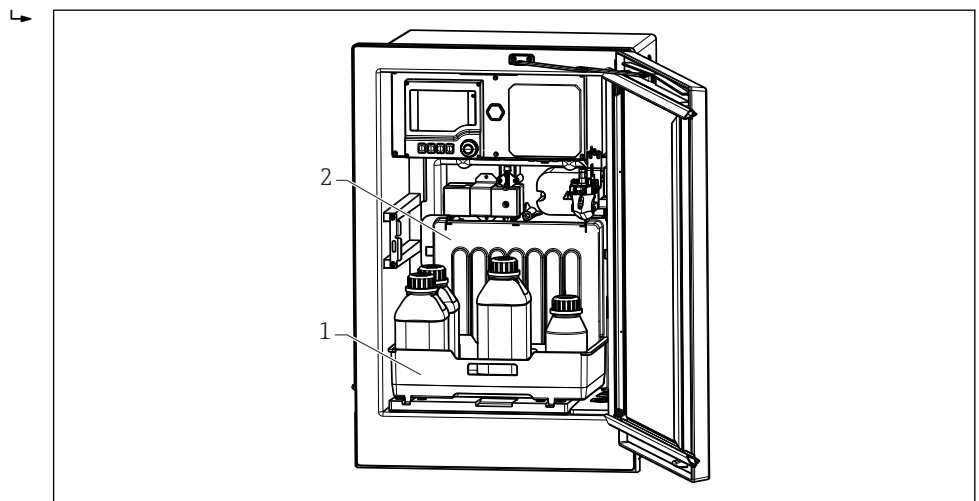

- 1 Bottle tray
2 Cover

4. Using a Torx screwdriver (T25), release the six screws on the carrier board (3) and fold out the board towards the front. For convenience of handling, hook the carrier board onto the locking plate.

5. Using a Phillips head screwdriver, release the six screws on the electronics compartment cover (4) and fold out the cover towards the front.

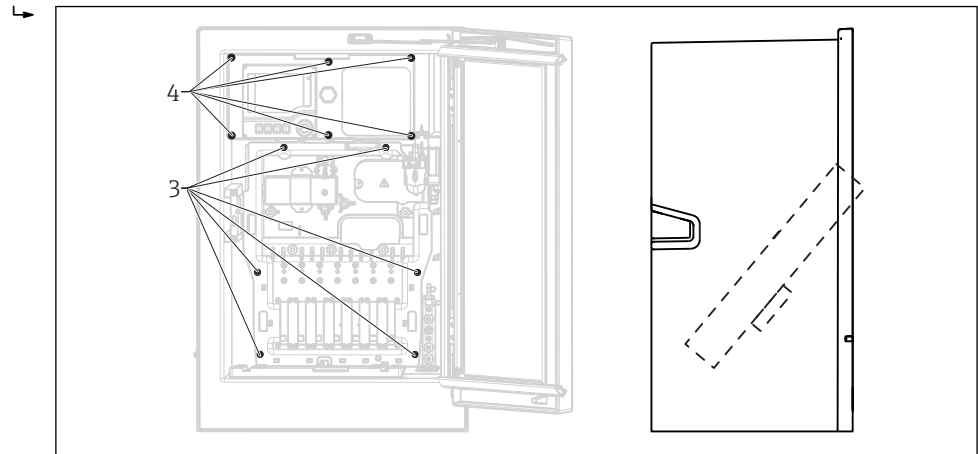

A0028912

- 3 Screws of carrier board
4 Screws of electronics compartment cover

6. Route the cables on the rear panel of the device so that they are properly protected. Cable glands are available for the cable entry.

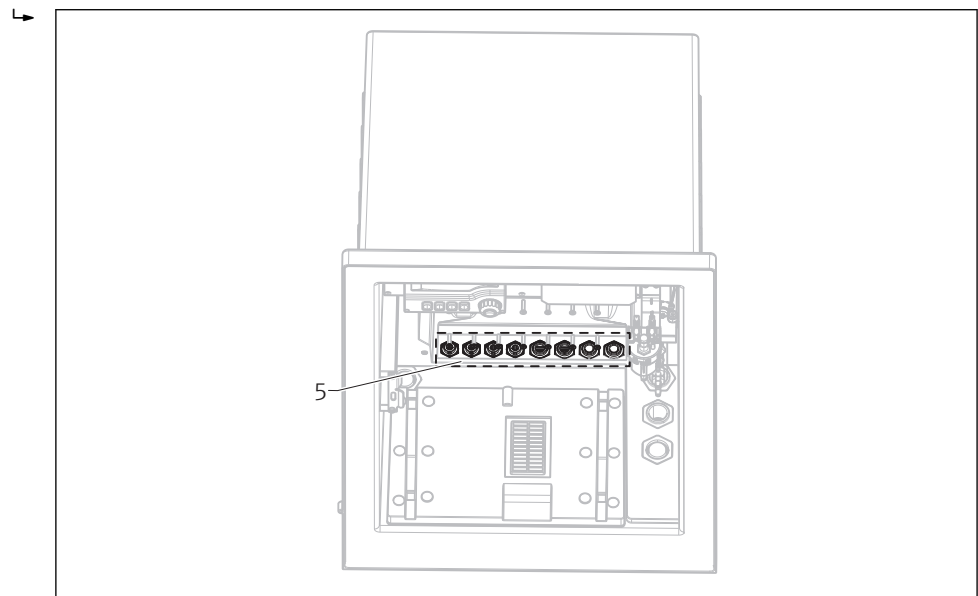

A0028913

- 5 Cable glands

- i** In the case of order versions with G' and NPT cable glands, the pre-mounted cable glands with an M-thread must be replaced by the G' or NPT glands enclosed.

This does not affect the M32 hose glands.

- i** For cabinet versions, the cable length is approx. 4.3 m (14.1 ft) from the housing floor.



For analyzer stands, the cable length is approx. 3.5 m (11.5 ft) from the foundation.

The terminal connection is located under an additional protective cover in the upper section of the device.

7. Use the six screws to secure the electronics compartment cover after connecting.
8. Use the six screws to secure the carrier plate after connecting.

6.1.3 Connecting 24 V devices

i In the case of devices with a 24 V power supply, the connection cross-section must be at least 2.5 mm² and may not exceed 4 mm². With 24V power supply, a current of up to 10A can flow. For this reason pay attention to the voltage drop on the supply line. The voltage at the device terminals must be within the specified range (see "Supply voltage" section).

1. To access the electronics compartment, proceed as described in the "Routing the cables" section.
2. Guide the 24V connecting cable from below through the cable gland on the inner rear panel of the device and feed it upwards into the electronics compartment.
3. Establish the connection as per →  20,  25

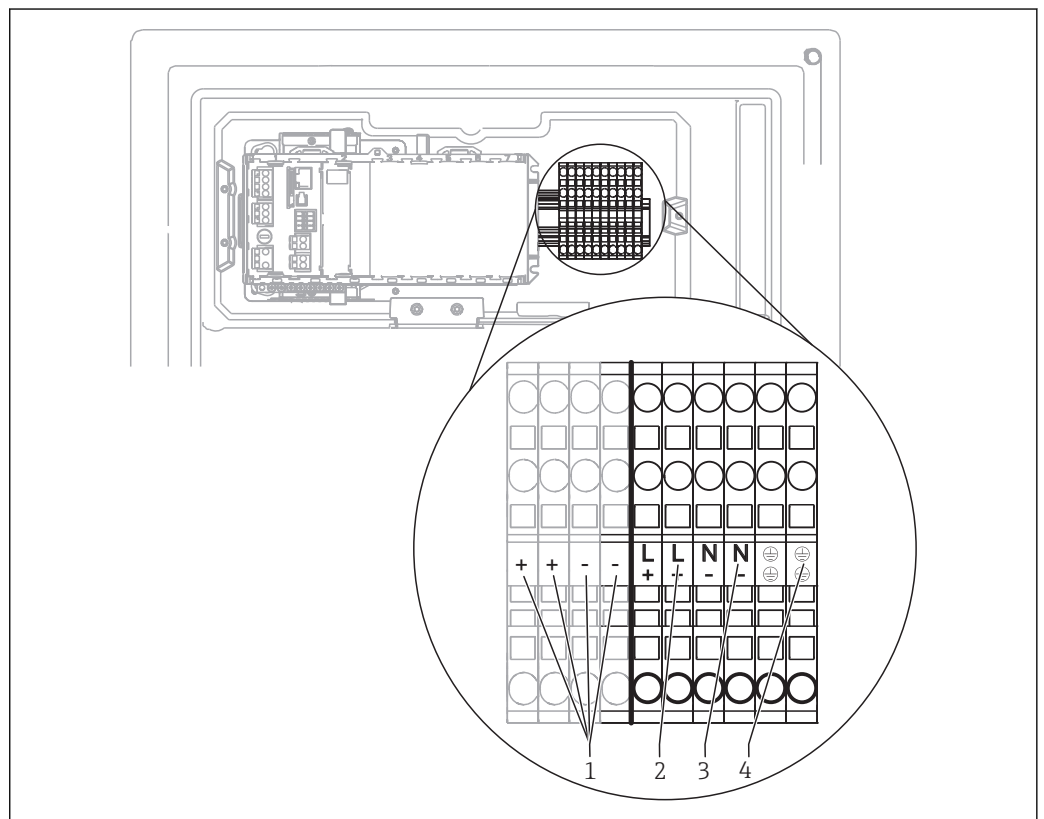

 20 Terminal assignment

- 1 Internal 24 V voltage
- 2 Power supply: +24 V
- 3 Power supply: -24 V
- 4 Assignment: protective ground

A0028910

6.2 Connecting sample preparation

6.2.1 Connecting the optional cleaning valve of Liquiline System CAT810

1. Disconnect the mains plug.
2. To fold out the carrier board towards the front, proceed as described in the "Routing the cables" section.

3. Guide the cable through the cable gland.

i In the case of order versions with G' and NPT cable glands, the pre-mounted cable glands with an M-thread must be replaced by the G' or NPT glands enclosed.

This does not affect the M32 hose glands.

Compliance with the protective grounding specifications is mandatory when installing the device.

4. Remove the protective cover in the upper right-hand corner.

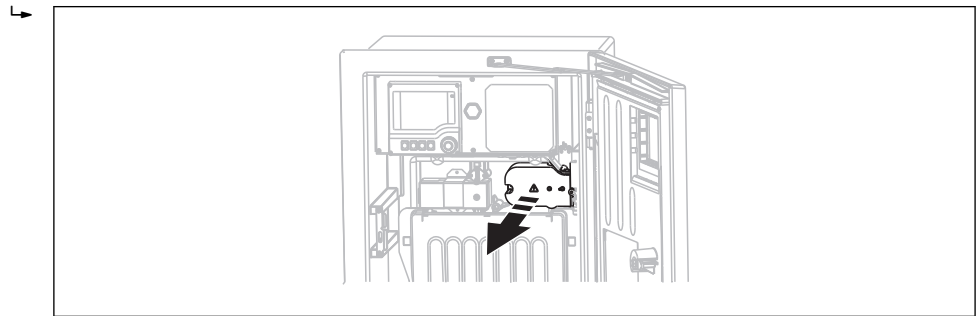

A0028925

5. Connect the cleaning valve to the following plug-in terminals:

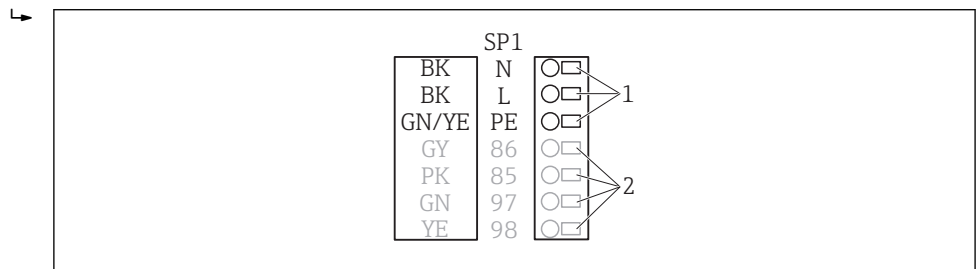

A0028926

21 Liquiline System CAT810 connection

- 1 Liquiline System CAT810, 100 to 120 V/200 to 240 V AC
2 Are not used

6. Secure the protective cover after connecting. Make sure that no cables or hoses are jammed

7. Use the six screws to secure the carrier plate after connecting.

6.2.2 Connecting the optional hose heater and communication between the CAT820/CAT860 and the analyzer

i Only use terminated genuine cables where possible. The sensor cable, fieldbus cable and Ethernet cable must be shielded cables.

Cable sample (does not necessarily correspond to the genuine cable supplied)

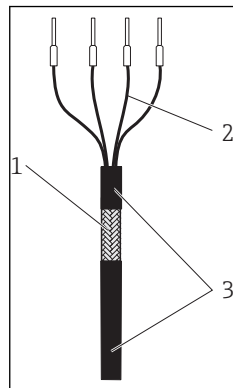

22 Terminated cable

- 1 Outer shield (exposed)
- 2 Cable cores with ferrules
- 3 Cable sheath (insulation)

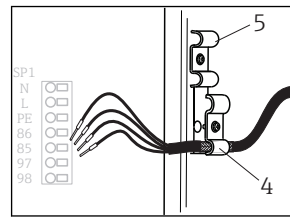

23 Inserting the cable

- 4 Shielding clamp for Memosens supply and power supply
- 5 Cable clamp for hose heating

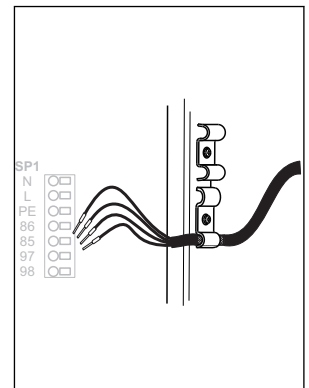

24 Tighten the screw (2 Nm)

1. Disconnect the mains plug.
2. To fold out the carrier board towards the front, proceed as described in the "Routing the cables" section.
3. Release a suitable hose gland on the right-hand underside of the analyzer and remove the dummy plug from the gland.
4. Guide the spiral hose through the hose gland.

i In the case of order versions with G' and NPT cable glands, the pre-mounted cable glands with an M-thread must be replaced by the G' or NPT glands enclosed.

This does not affect the M32 hose glands.

Compliance with the protective grounding specifications is mandatory when installing the device.

5. Remove the protective cover in the upper right-hand corner.

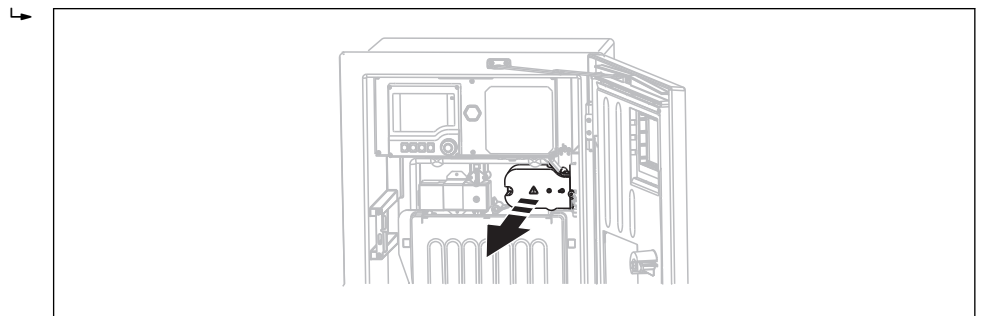

A0028925

6. Route the cable in the housing in such a way that the **exposed** cable shield fits into one of the cable clamps and the cable cores can be easily routed as far as the plug-in terminals.
7. Screw on the cable clamp and clamp the cable in place. Then tighten the screw of the cable clamp.

8. Connect the cable or cables (depending on the version) to the following plug-in terminals:

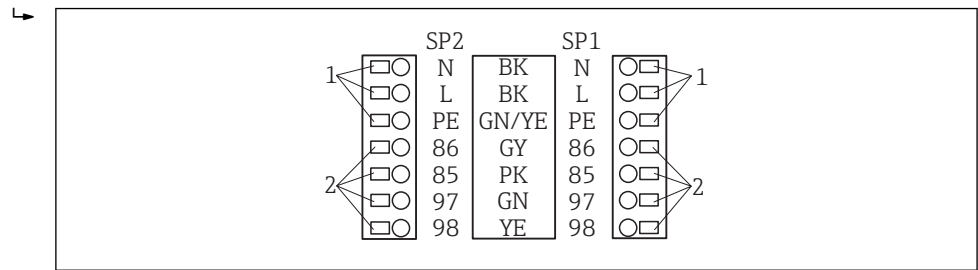

A0028924

25 Connection of Liquiline System CAT820 / 860

- 1 Hose heater 100 to 120 V/200 to 240 V AC (optional)
- 2 Connections for Memosens and communication with analyzer (optional)

9. Secure the protective cover after connecting. Make sure that no cables or hoses are jammed.
10. Use the six screws to secure the carrier plate after connecting.

6.3 Connecting the sensors and additional modules

6.3.1 Overview of connection compartment in the controller housing

The controller housing has a separate connection compartment. Release the 6 screws in the electronics compartment cover (1) to open the compartment:

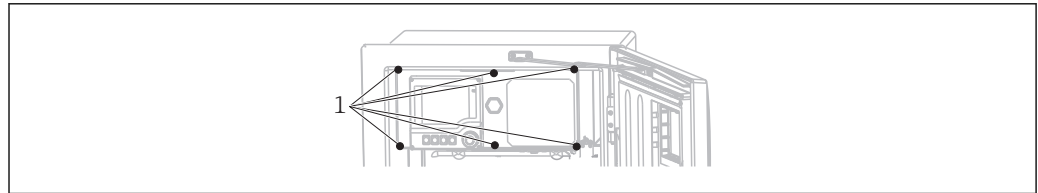

A0030429

1 Screws of electronics compartment cover

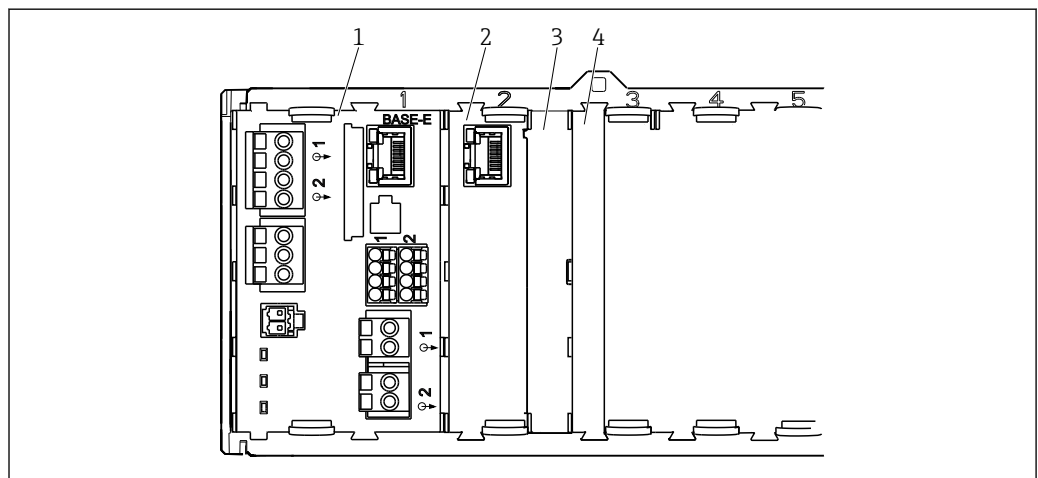

A0028935

26 Connection compartment in the controller housing

- 1 E basic module
- 2 Analyzer interface
- 3 Dummy cover
- 4 Module cover

E base module

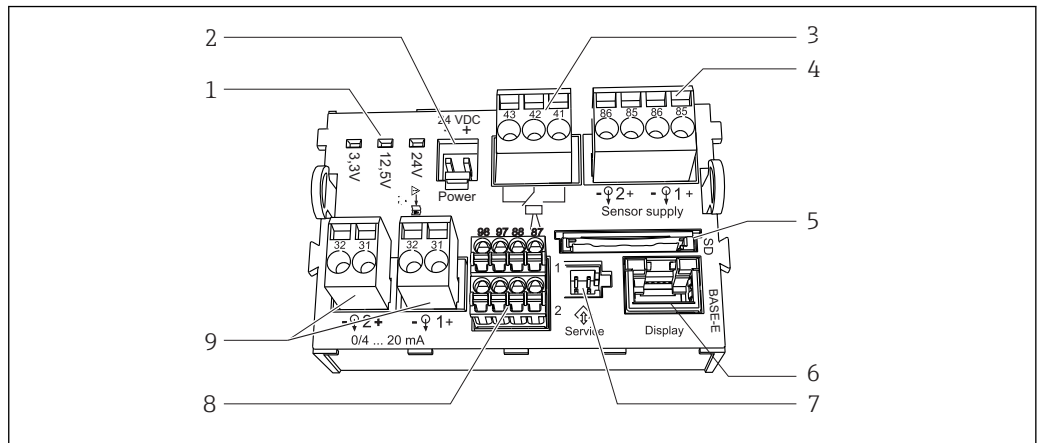

A0016535

27 E basic module

- 1 Indicator LEDs
- 2 Voltage connection ¹⁾
- 3 Alarm relay connection
- 4 Power supply for digital fixed cable sensors with Memosens protocol
- 5 SD card slot
- 6 Slot for display cable ¹⁾
- 7 Service interface ¹⁾
- 8 Connections for 2 Memosens sensors (optional)
- 9 Current outputs

1) Internal device connection. Do not disconnect the plug!

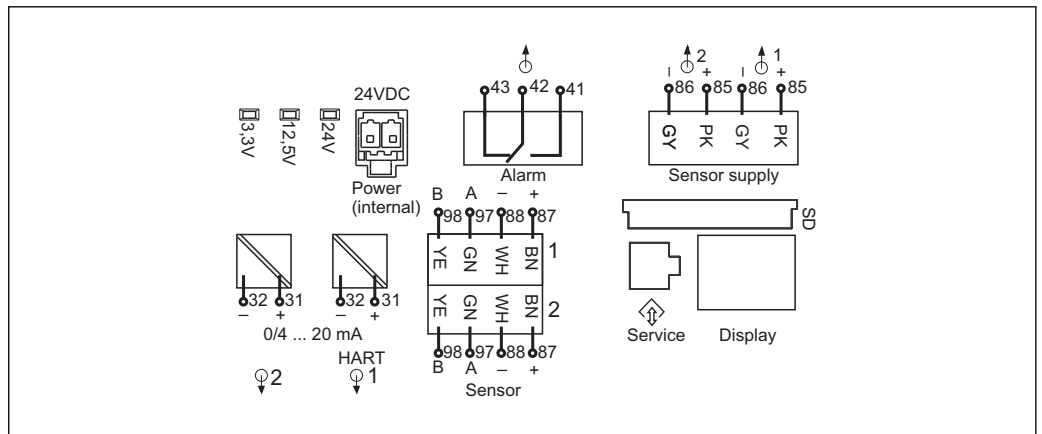

A0016537

28 E basic module wiring diagram

6.3.2 Connecting the sensors

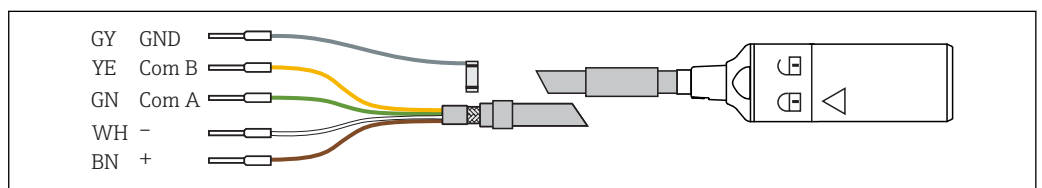

i Only use terminated genuine cables where possible.



A0024019

29 Example of Memosens data cable CYK10

Connecting the ferrules of the sensor cable to the E basic module

1. To access the electronics compartment, proceed as described in the "Routing the cables" section.
2. Guide the sensor connecting cable from below through the cable gland on the inner rear panel of the device and feed it upwards into the electronics compartment.
3. Establish the connection as per →  29,  29
4. Ground the outer shield of the cable via the metal gland under the E basic module.

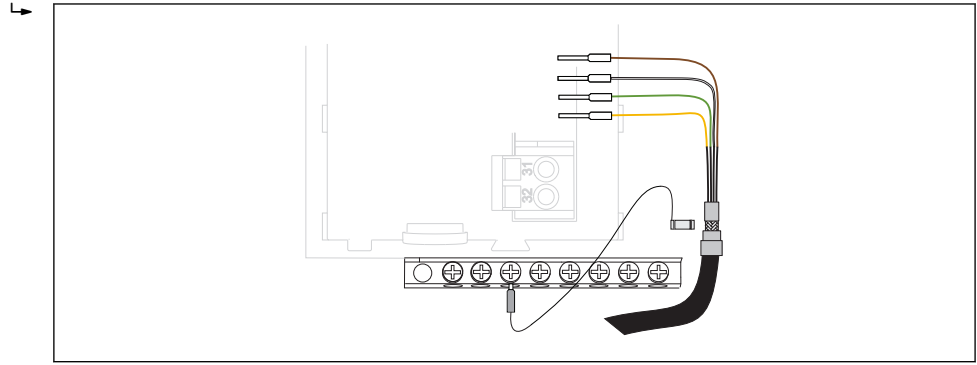

 30 Terminal strip



A0028930

6.3.3 Connecting additional inputs, outputs or relays

⚠ WARNING

Module not covered



No shock protection. Danger of electric shock!

- ▶ If you are modifying or extending your hardware, always fill the slots from left to right. Do not leave any gaps.
- ▶ If all of the slots are not occupied: Always insert a dummy cover or end cover in the slot to the right of the last module →  26,  28. This ensures that the unit is shock-protected.
- ▶ Always ensure shock protection is guaranteed particularly in the case of relay modules (2R, 4R, AOR).

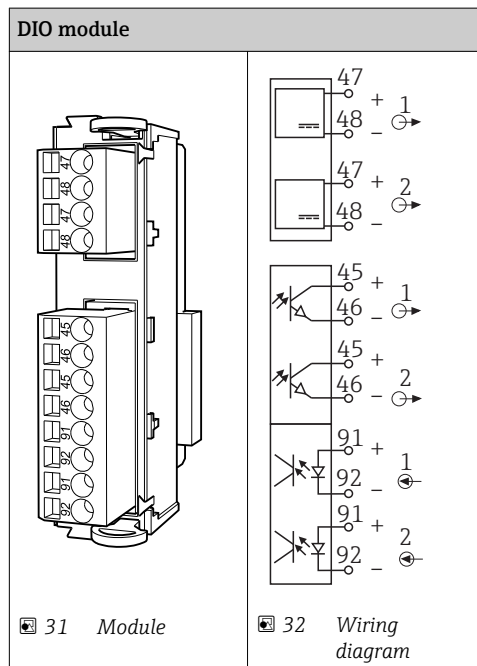

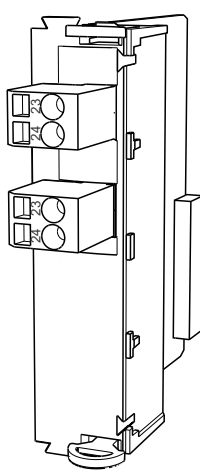
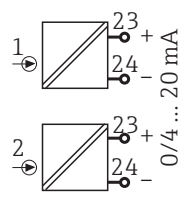

Digital inputs and outputs

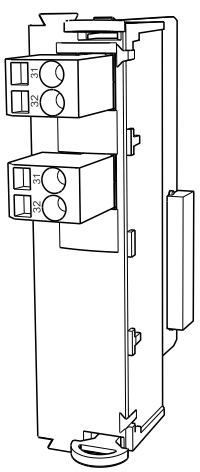
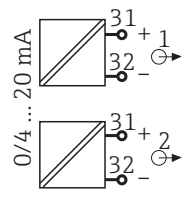
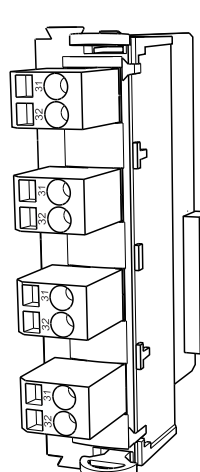
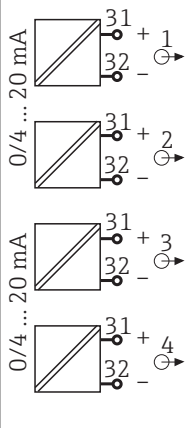

Current inputs

2AI module	
	
 33 Module	 34 Wiring diagram

Current outputs

2AO		4AO	
			
 35 Module	 36 Wiring diagram	 37 Module	 38 Wiring diagram

Relay

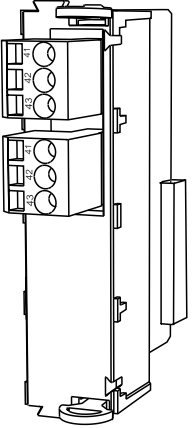
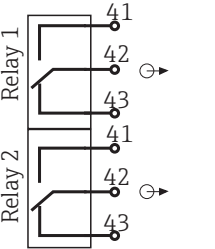
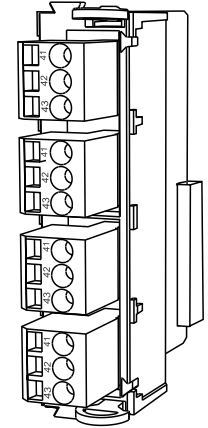
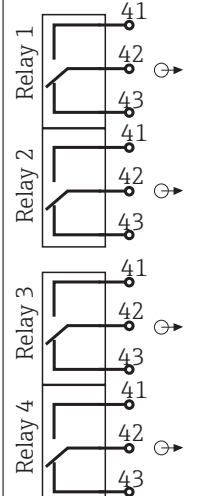
2R module		4R module	
			
<p>▣ 39 Module</p>	<p>▣ 40 Wiring diagram</p>	<p>▣ 41 Module</p>	<p>▣ 42 Wiring diagram</p>

Example: Connecting the cleaning unit 71072583 for CAS40D

NOTICE

Power consumption too high for the Liquiline alarm relay

Can cause irreparable damage to the base module

- ▶ Only connect the cleaning unit to terminals of an additional module (AOR, 2R or 4R), **not** to the alarm relay of the base module.

Example: Connecting the Chemoclean CYR10 injector cleaning unit

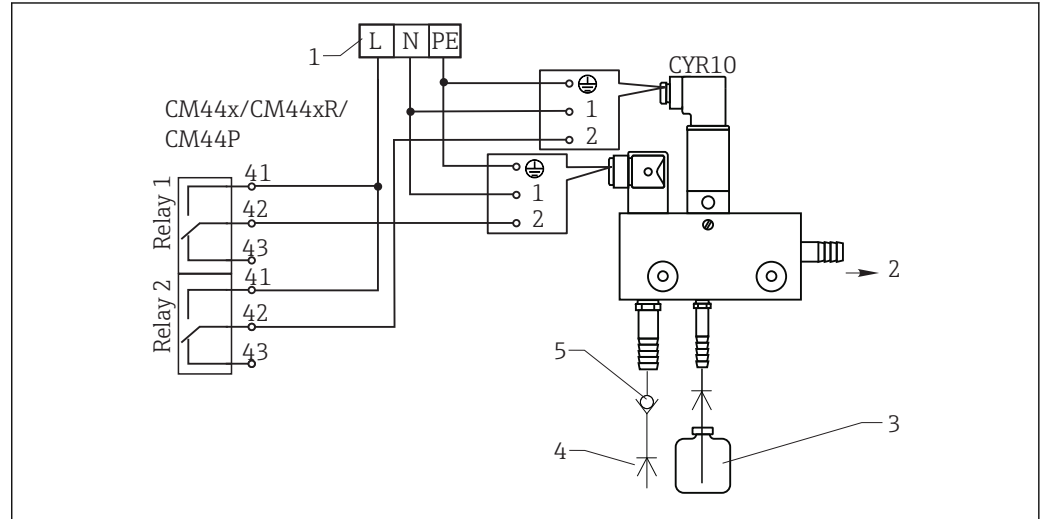

43 Connecting the CYR10 injector cleaning unit

- 1 External power supply
- 2 Cleaner to spray head
- 3 Container with cleaner
- 4 Motive water 2 to 12 bar (30 to 180 psi)
- 5 Backflow valve (to be provided by the customer)

6.3.4 Connecting digital communication

Module 485

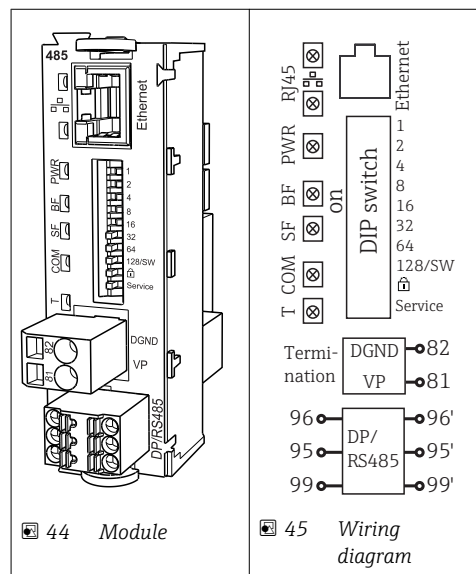

44 Module

45 Wiring diagram

Terminal	PROFIBUS DP	Modbus RS485
95	A	B
96	B	A
99	Not connected	C
82	DGND	DGND
81	VP	VP

LEDs on front of module

LED	Description	Color	Description
RJ45	LNK/ACT	GN	<ul style="list-style-type: none"> ■ Off = Connection is not active ■ On = Connection is active ■ Flashing = Data transmission
RJ45	10/100	YE	<ul style="list-style-type: none"> ■ Off = Transmission rate 10 MBit/s ■ On = Transmission rate 100 MBit/s
PWR	Power	GN	Supply voltage is applied and module is initialized
BF	Bus failure	RD	Bus failure
SF	System failure	RD	Device error
COM	Communication	YE	Modbus message sent or received
T	Bus termination	YE	<ul style="list-style-type: none"> ■ Off = No termination ■ On = Termination is used

DIP switches on front of module

DIP	Factory setting	Assignment
1-128	ON	Bus address (→ "Commissioning/communication")
	OFF	Write protection: "ON" = configuration not possible via the bus, only via local operation
Service	OFF	If the switch is set to "ON", the user settings for Ethernet addressing are saved and connection settings programmed into the device at the factory are activated: IP address=192.168.1.212, Subnet mask=255.255.255.0, Gateway=0.0.0.0, DHCP=Off. If the switch is set to "OFF", the saved user settings are reactivated.

Module ETH

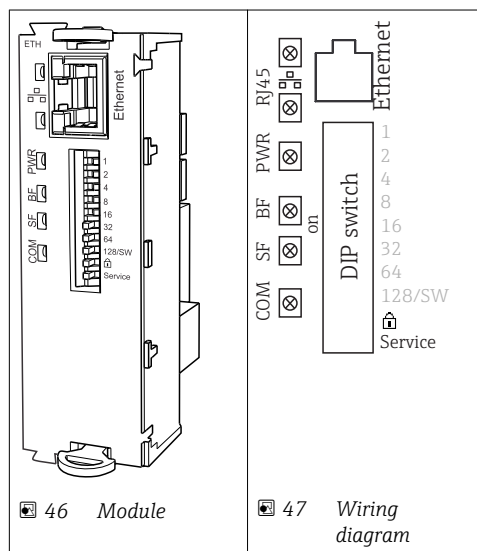

LEDs on front of module

LED	Designation	Color	Description
RJ45	LNK/ACT	GN	<ul style="list-style-type: none"> ■ Off = Connection is not active ■ On = Connection is active ■ Flashing = Data transmission
RJ45	10/100	YE	<ul style="list-style-type: none"> ■ Off = Transmission rate 10 MBit/s ■ On = Transmission rate 100 MBit/s
PWR	Power	GN	Supply voltage is applied and module is initialized
BF	Bus failure	RD	Not used
SF	System failure	RD	Device error
COM	Communication	YE	Modbus message sent or received

DIP switches on front of module

DIP	Factory setting	Assignment
1-128	ON	Bus address (→ "Commissioning/communication")
	OFF	Write protection: "ON" = configuration not possible via the bus, only via local operation
Service	OFF	If the switch is set to "ON" , the user settings for Ethernet addressing are saved and connection settings programmed into the device at the factory are activated: IP address=192.168.1.212, Subnet mask=255.255.255.0, Gateway=0.0.0.0, DHCP=Off. If the switch is set to "OFF" , the saved user settings are reactivated.

6.4 Hardware settings

6.4.1 Bus termination (module 485 only)

There are two ways to terminate the bus:

1. Internal terminating resistor (via DIP switch on the module board)

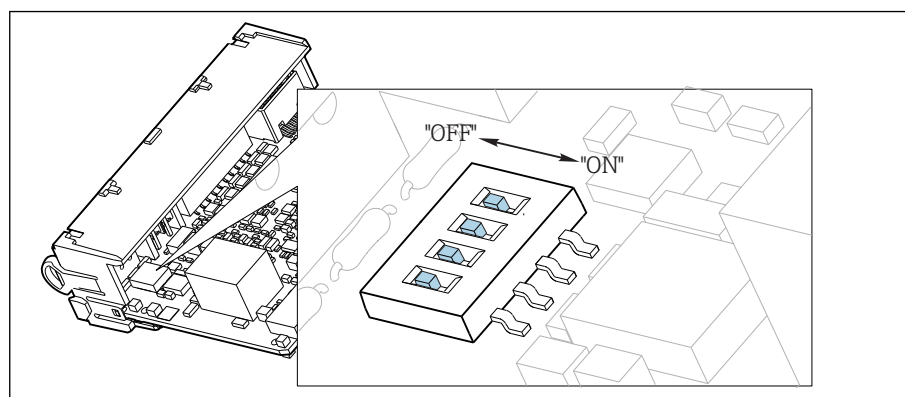

 48 *DIP switches for internal terminating resistor*

- ▶ Using a suitable tool, such as a tweezers, set all 4 DIP switches to the "ON" position.
 - ↳ The internal terminating resistor is used.

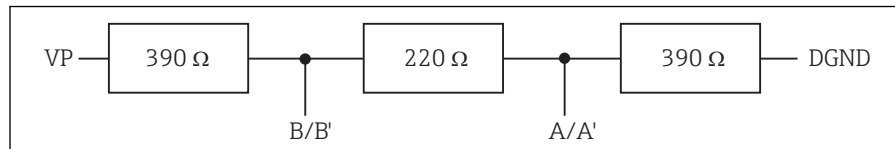

49 Structure of the internal terminating resistor

2. External terminating resistor

Here, leave the DIP switches on the module board in the "OFF" position (factory setting).

- ▶ Connect the resistor to terminals 81 and 82 on the front of module 485 for 5-V power supply.
 - ↳ The external terminating resistor is used.

6.4.2 Bus address

Setting the bus address

1. Open the housing.
2. Set the desired bus address via the DIP switches of module 485.

i For PROFIBUS DP, valid bus addresses are anything between 1 and 126, and anything between 1 and 247 for Modbus. If you configure an invalid address, software addressing is automatically enabled via the local configuration or via the fieldbus.

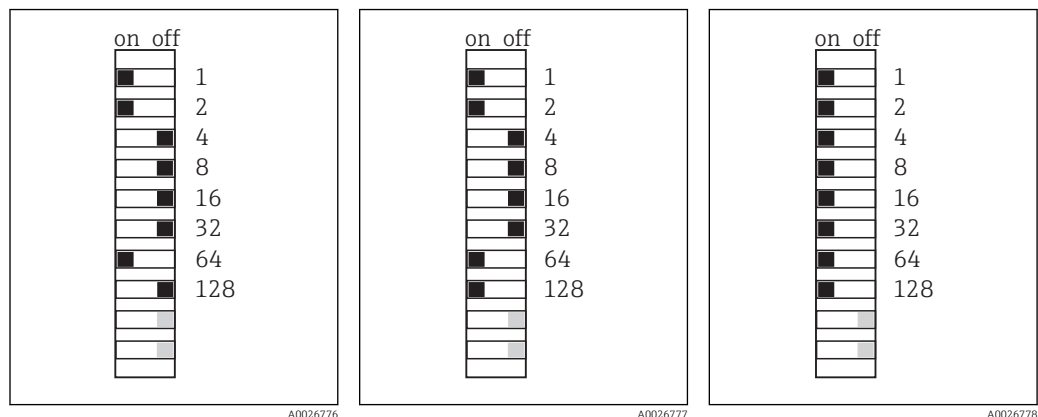

50 Valid PROFIBUS address 67 51 Valid Modbus address 195 52 Invalid address 255 ¹⁾

¹⁾ Order configuration, software addressing is active, software address configured at the factory: PROFIBUS 126, Modbus 247

6.5 Ensuring the degree of protection

Only the mechanical and electrical connections which are described in these instructions and which are necessary for the required, designated use, may be carried out on the device delivered.

- ▶ Exercise care when carrying out the work.

Individual types of protection confirmed for this product (impermeability (IP), electrical safety, EMC interference immunity, Ex protection) can no longer be guaranteed if, for example:

- Covers are left off.
- Different power units to the ones supplied are used.
- Cable glands are not sufficiently tightened (must be tightened with 2 Nm for the confirmed level of IP protection).

- Unsuitable cable diameters are used for the cable glands provided.
- Modules are not fully secured.
- The display is not fully secured (risk of moisture entering due to inadequate sealing).
- Cables/cable ends are loose or insufficiently secured.
- Conductive cable strands are left in the device.

6.6 Post-connection check

WARNING

Connection errors

The safety of people and of the measuring point is under threat. The manufacturer does not accept any responsibility for errors that result from failure to comply with the instructions in this manual.

- ▶ Operate the device only if you can answer **yes** to **all** of the following questions.

Instrument status and specifications

- ▶ Is there any external damage to the device and cables?

Electrical connection

- ▶ Are the mounted cables strain-relieved?
- ▶ Have the cables been routed without loops and cross-overs?
- ▶ Have the signal lines been connected correctly in accordance with the wiring diagram?
- ▶ Are all plug-in terminals securely engaged?
- ▶ Are all the connection wires securely positioned in the cable terminals?

7 System integration

7.1 Web server

7.1.1 Connection

- ▶ Connect the PC communication cable to the RJ45 port of module 485 or module ETH.

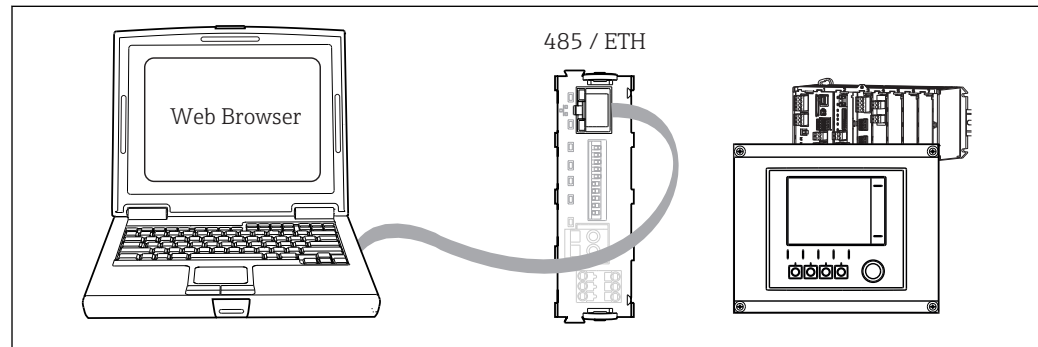

53 Web server/Ethernet connection

A0026779

7.1.2 Establishing the data connection

To ensure that your device has a valid IP address, you must disable the **DHCP** parameter in the Ethernet settings. (**Menu/Setup/General settings/Extended setup/Ethernet/Settings**)

You can then set the IP address in the same menu.

1. Start your PC.
2. First, set a manual IP address in the network connection settings of the operating system.

Example: Microsoft Windows 7

Via the Control Panel, go to the Network and Sharing Center. You should see an active "Local Area Connection" link. Select this link.

- ▶ In the pop-up window select the "Properties" button.
- ▶ Double click "Internet Protocol Version 4 (TCP/IPv4)".
- ▶ Select "Use the Following IP Address".
- ▶ Enter the desired IP address.

This address must be in the same subnetwork as the IP address of the device, e.g.:

- IP address of Liquiline: 192.168.1.212 (as configured previously)
- IP address for the PC: 192.168.1.213

3. Start the Internet browser.
4. If you use a proxy server to connect to the Internet:
Disable the proxy (browser settings under "Connections/LAN settings").
5. Enter the IP address of your device in the address line (192.168.1.212 in the example).
 - ↳ The system takes a few moments to establish the connection and then the CM44 web server starts. You might be asked for a password. The factory setting is "admin" for the user name and "admin" for the password.

- ▶ Enter the following address(es) to download logbooks:
 - ↳ 192.168.1.212/logbooks_csv.fhtml (for logbooks in CSV format)
 - 192.168.1.212/logbooks_fdm.fhtml (for logbooks in FDM format)

i Downloads in FDM format can be securely transmitted, saved and visualized with Endress+Hauser's "Field Data Manager Software".
 (→ www.endress.com/ms20)

7.1.3 Operation

The menu structure of the web server corresponds to the onsite operation.

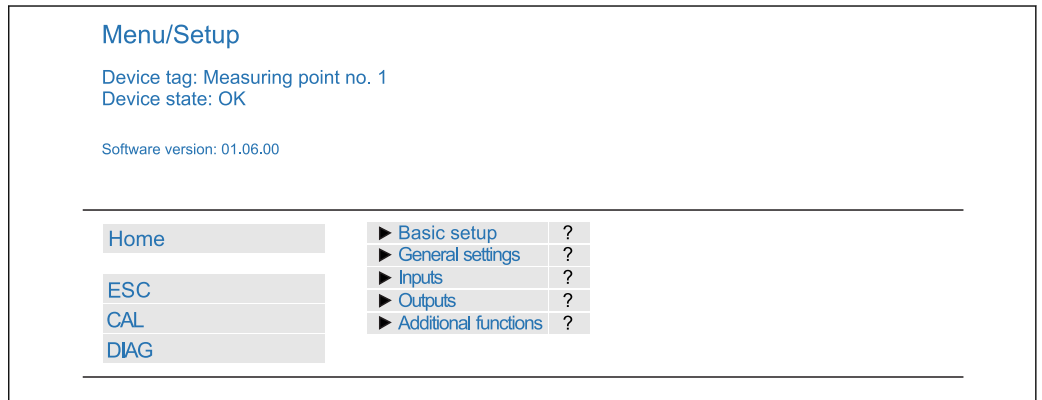

54 Example of web server (menu/language=English)

- Clicking a menu name or a function corresponds to pressing the navigator.
- You can make your settings conveniently via the computer keyboard.

i Instead of using an Internet browser, you can also use FieldCare for configuration via ethernet. The ethernet DTM required for this is an integral part of the "Endress +Hauser Interface Device DTM Library".

Download: <https://portal.endress.com/webdownload/FieldCareDownloadGUI/>

7.2 Service interface

You can connect the device to a computer via the service interface and configure it using "Fieldcare". Furthermore, configurations can also be saved, transferred and documented.

7.2.1 Connection

1. Connect the service connector to the interface on the Liquiline base module and connect it to the Commubox.
2. Via the USB port, connect the Commubox to the computer running the Fieldcare software.

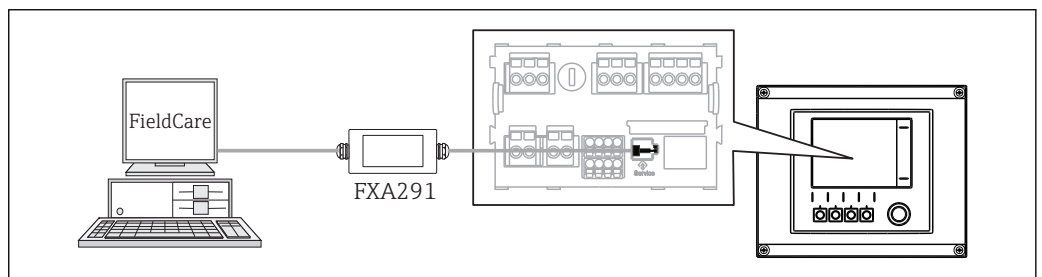

55 Connection overview

7.2.2 Creating the data connection

1. Start Fieldcare.
2. Establish a connection to the Commubox. For this, select the ComDTM "CDI Communication FXA291"
3. Then select the "Liquiline CM44x" DTM and start the configuration.

You can now start online configuration via the DTM.

Online configuration competes with onsite operation, i.e. each of the two options blocks the other one. On both sides it is possible to take away access from the other side.

7.2.3 Operation

- In the DTM the menu structure corresponds to the onsite operation. The functions of the Liquiline soft keys are found in the main window on the left.
- Clicking a menu name or a function corresponds to pressing the navigator.
- You can make your settings conveniently via the computer keyboard.
- Via Fieldcare, you can save logbooks, make backups of configurations and transfer the configurations to other devices.
- You can also print out configurations or save them as PDFs.

7.3 Fieldbuses

7.3.1 PROFIBUS DP

With the fieldbus module 485 and the appropriate device version, you can communicate via PROFIBUS DP.

- ▶ Connect the PROFIBUS data cable to the terminals of the fieldbus module as described ().

 More detailed information on PROFIBUS communication is provided on the product pages on the Internet (→ SD01188C).

7.3.2 Modbus

With the fieldbus module 485 and the appropriate device version, you can communicate via Modbus RS485 or Modbus TCP.

For Modbus TCP, you can use the ETH module as an alternative to module 485.

The RTU and ASCII protocols are available when connecting via Modbus RS485. You can switch to ASCII on the device.

- ▶ Connect the Modbus data cable to the terminals of the fieldbus module (RS 485) or to the RJ45 (TCP) port as described.

 More detailed information on Modbus communication is provided on the product pages on the Internet (→ SD01189C).

7.3.3 EtherNet/IP

With the fieldbus module 485 or the ETH module and the appropriate device version, you can communicate via EtherNet/IP.

- ▶ Connect the EtherNet/IP data cable to the RJ45 socket of module 485 or ETH.

 More detailed information on EtherNet/IP communication is provided on the product pages on the Internet (→ SD01293C).

8 Operation options

8.1 Overview

8.1.1 Display and operating elements

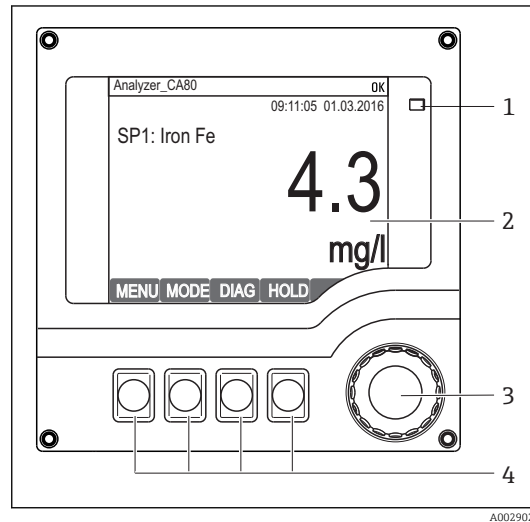

- 1 LED
- 2 Display (with red display background in alarm condition)
- 3 Navigator (jog/shuttle and press/hold function)
- 4 Soft keys (function depends on menu)

56 Overview of operation

8.1.2 Display

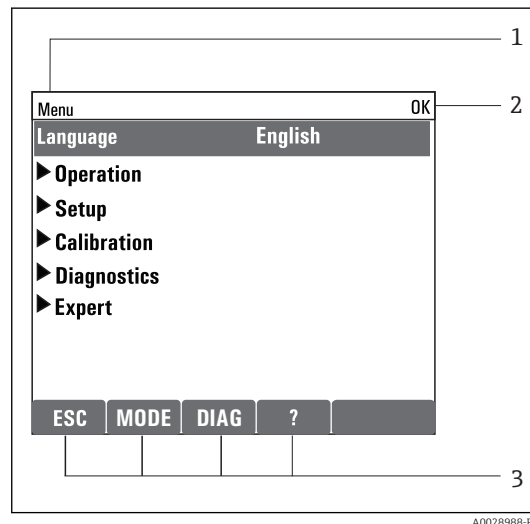

- 1 Menu path and/or device designation
- 2 Status display
- 3 Assignment of the soft keys, e.g. ESC: escape or abortion of a sampling process
MODE: quick access to frequently required functions
DIAG: link to Diagnostics menu
?: Help, if available

57 Display (example)

8.2 Access to the operating menu via the local display

8.2.1 Operation concept

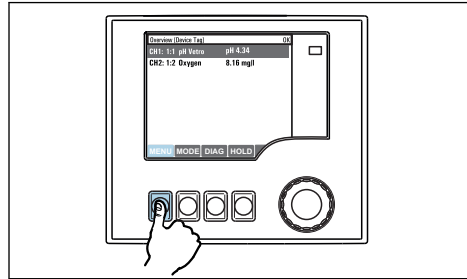

Pressing the soft key: selecting the menu directly

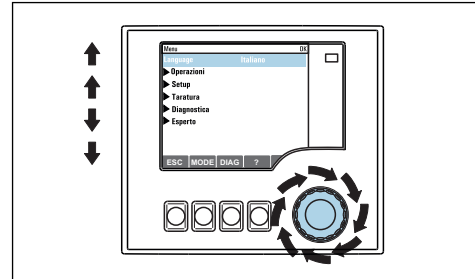

Turning the navigator: moving the cursor in the menu

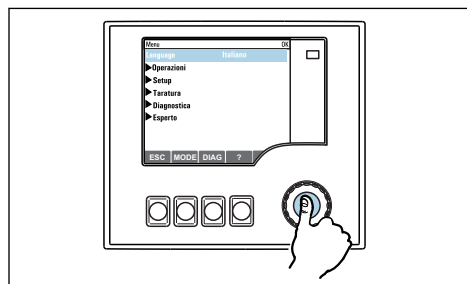

Pressing the navigator: launching a function

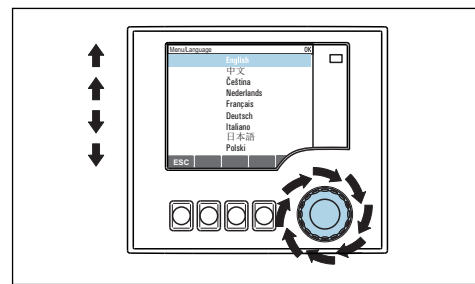

Turning the navigator: selecting a value (e.g. from a list)

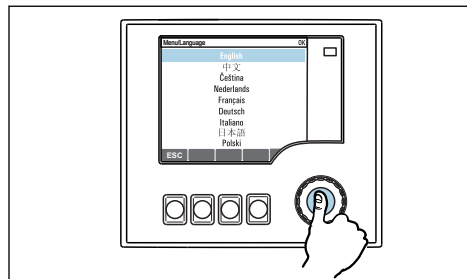

Pressing the navigator: accepting the new value

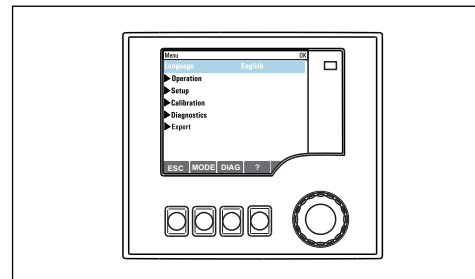

↳ New setting is accepted

8.2.2 Locking or unlocking operating keys

Locking operating keys

1. Press the navigator for longer than 2 s.
 - ↳ A context menu for locking the operating keys is displayed. You have the choice of locking the keys with or without password protection. "With password" means that you can only unlock the keys again by entering the correct password. This password is set here: **Menu/Setup/General settings/Extended setup/Data management/Change lock password.**
2. Choose whether you want to lock without or without a password.
 - ↳ The keys are locked. No more entries can be made. In the soft key bar, you will see the  symbol.

 The password is 0000 when the device is delivered from the factory. **Make sure to note down any changes to the password**, as otherwise you will not be able to unlock the keypad yourself.

Unlocking operating keys

1. Press the navigator for longer than 2 s.
 - ↳ A context menu for unlocking the operating keys is displayed.
2. Select **Key unlock**.
 - ↳ The keys are unlocked immediately if you did not choose to lock with a password. Otherwise you are asked to enter your password.
3. Only if keypad is password-protected: enter the right password.
 - ↳ The keys are unlocked. It is possible to access the entire onsite operation again. The  symbol is no longer visible on the display.

8.3 Configuration options

8.3.1 Display only

- You can only read the values but cannot change them.
- Typical read-only values are: analyzer data, sensor data and system information
- Example: **Menu/Setup/Analyzer/./Measuring parameter**

8.3.2 Picklists

- You receive a list of options. In a few cases, these also appear in the form of multiple choice boxes.
- Usually you just select one option; in rare instances you select one or more options.
- Example: **Menu/Setup/General settings/Temperature unit**

8.3.3 Numerical values

- You are changing a variable.
- The maximum and minimum values for this variable are shown on the display.
- Set a value within this range.
- Example: **Menu/Operation/Display/Contrast**

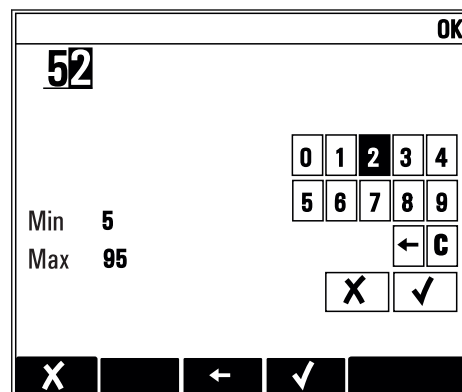

8.3.4 Actions

- You trigger an action with the appropriate function.
- You know that the item in question is an action if it is preceded by the following symbol: 
- Examples of typical actions include:
 - Deleting log entries
 - Saving or loading configurations
 - Triggering cleaning programs
- Example: **Menu/Setup/Analyzer/Manual operation**

8.3.5 Free text

- You are assigning an individual designation.
- Enter a text. You can use the characters in the editor for this purpose (upper-case and lower-case letters, numbers and special characters).
- Using the soft keys, you can:
 - Cancel your entries without saving the data (X)
 - Delete the character in front of the cursor (X)
 - Move the cursor back one position (←)
 - Finish your entries and save (✓)

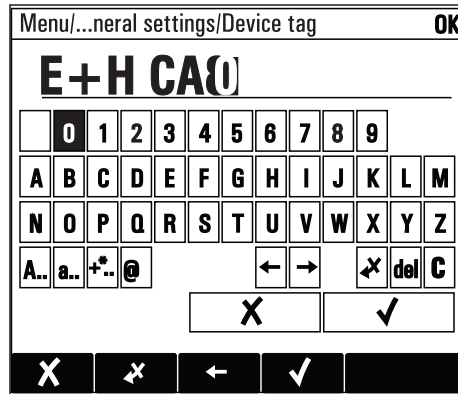

8.3.6 Tables

- Tables are needed to map mathematical functions .
- You edit a table by navigating through rows and columns with the navigator and changing the values of the cells.
- You only edit the numerical values. The controller automatically takes care of the engineering units.
- You can add lines to the table (**INSERT**) or delete lines from the table (**DEL**).
- Afterwards, you save the table (**SAVE**).
- You can also cancel your entries any time using the **X** soft key.
- Example: **Menu/Setup/Inputs/pH/Medium comp.**

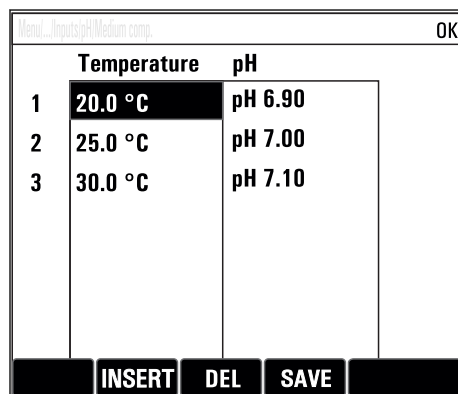

9 Commissioning

9.1 Preparatory steps

9.1.1 Connecting the liquid-bearing suction lines

 First connect the liquid-bearing lines and visually inspect the hoses before establishing the connection to the power supply. It is possible that both the sample preparation and the analyzer will start directly and supply sample into the device.

The reagents used can pose a health hazard. Pay attention to the information in the reagent safety data sheets.

 **CAUTION**

Automatic cleaning function for the suction hose

Risk of injury from contact with very acidic cleaning solution

- ▶ Do not shorten the system intake hose.

 **CAUTION**

Analyzer in operation and during maintenance activities

Risk of injury and infection from medium

- ▶ Before hoses are released make sure that no action, such as the pumping of sample, is currently running or is due to start soon.
- ▶ Wear protective clothing, goggles and gloves or take other suitable measures to protect yourself.
- ▶ Wipe up any escaping reagent using a disposable cloth and rinse with clear water. Then dry the cleaned areas with a cloth.

1. Connect the liquid-bearing hoses of the sample supply system.
2. Self-priming: Connect the intake hose supplied (1.5 m) to the liquid manager ("sample") (see hose connection diagram), and guide the hose through the analyzer's hose gland to the outside.
3. If present, connect the communication cable and hose heater of the sample preparation system to the analyzer.

 Ensure that only sample that has a low solids content is supplied, as otherwise there is a risk of blockage. The customer must guarantee a constant and sufficient volume of sample.

Hose connection diagram

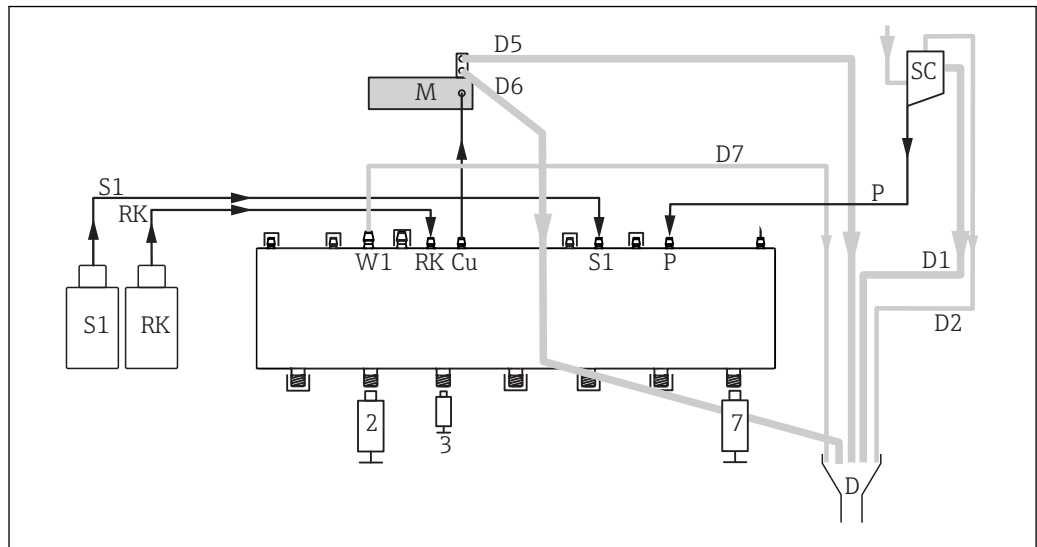

A0029034

58 *Liquiline System CA80FE, single-channel device*

- ▶ Route hose D6 with a continuous downward gradient from M to D.

S1	Standard 1	P	Sample
RK	Reagent RK	2, 3, 7	Dispensers
W1	Procedure	D	Procedure
Cu	Photometer cuvette	SC	Sample collecting vessel
M	Photometer/measuring cell		

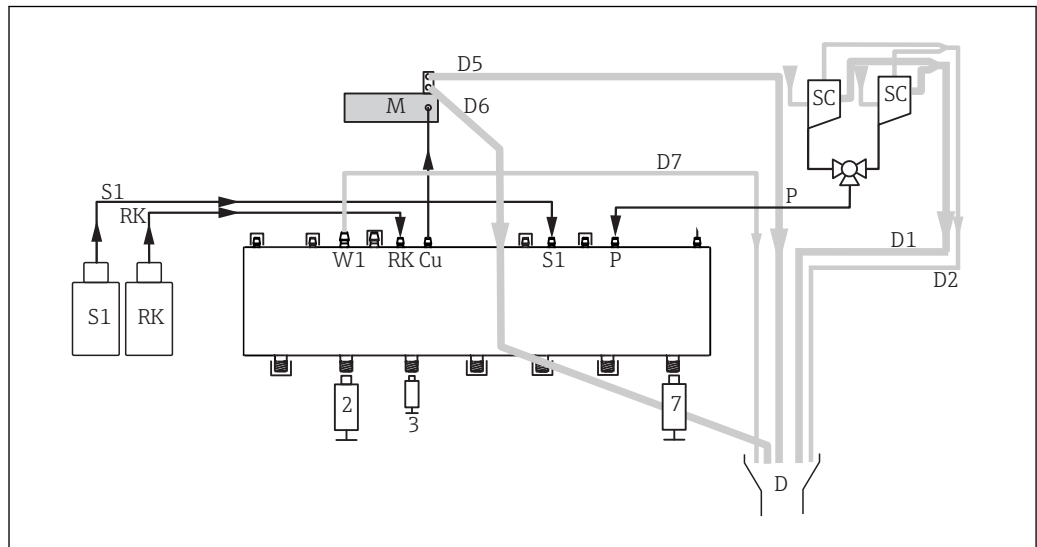

A0029035

59 *Liquiline System CA80FE, two-channel device*

- ▶ Route hose D6 with a continuous downward gradient from M to D.

S1	Standard 1	P	Sample
RK	Reagent RK	2, 3, 7	Dispensers
W1	Procedure	D	Procedure
Cu	Photometer cuvette	SC	Sample collecting vessel
M	Photometer/measuring cell		

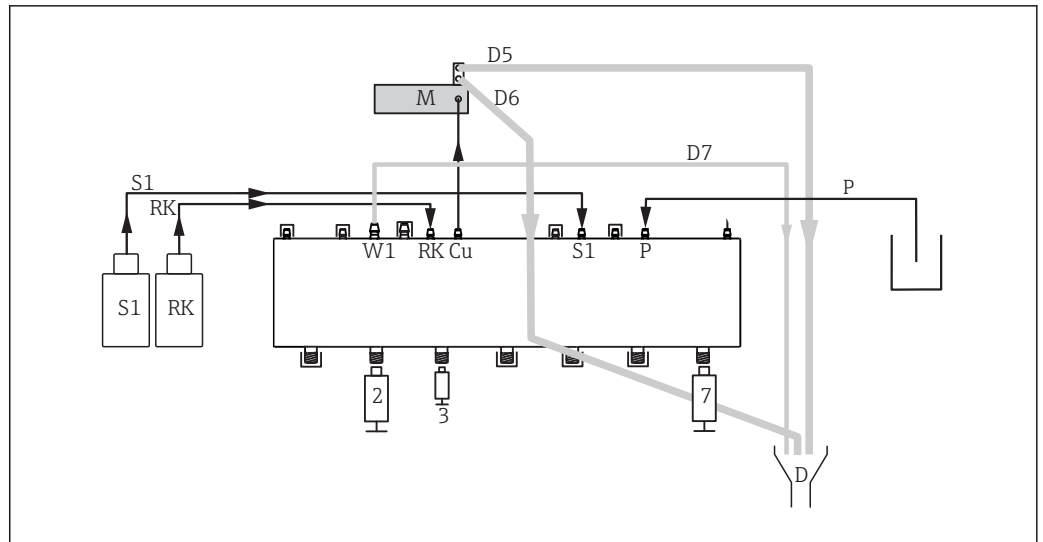

A0033655

60 Liquiline System CA80FE, self-priming

- ▶ Route hose D6 with a continuous downward gradient from M to D.

S1	Standard 1	P	Sample
RK	Reagent RK	2, 3, 7	Dispensers
W1	Procedure	D	Procedure
Cu	Photometer cuvette	SC	Sample collecting vessel
M	Photometer/measuring cell		

9.2 Function check

WARNING

Incorrect connection, incorrect supply voltage

Safety risks for staff and device malfunctions

- ▶ Check that all connections have been established correctly in accordance with the wiring diagram.
- ▶ Ensure that the supply voltage matches the voltage indicated on the nameplate.

Before putting the device into operation:

1. Connect the liquid-bearing hoses of the sample supply system.
2. If present, connect the communication cable and hose heater of the sample preparation system to the analyzer.

- After mounting, check all the connections to ensure they are secure and leak-tight.
- Check that the hoses of the sample preparation system are mounted correctly in the hose glands. It should not be possible to remove the hoses without the application of force.
- Visually inspect all the hose connections to ensure everything is correct.

WARNING

Connection errors

The safety of people and of the measuring point is under threat. The manufacturer does not accept any responsibility for errors that result from failure to comply with the instructions in this manual.

- ▶ Put the device into operation only if you can answer **yes** to **all** the following questions.

Instrument status and specifications

- ▶ Are the hoses free from damage on the outside?

Visual inspection of the liquid-bearing lines

- ▶ Is the suction line connected to the sample collector (if present)?
- ▶ Are the dispensers inserted correctly?
- ▶ Can the dispensers move up and down freely?
- ▶ Are all the hose connections leak-tight?
- ▶ If sample preparation is provided: has the connection been made? Are the protective hoses in the hose glands strain-relieved?
- ▶ If sample preparation is not connected: is the sample hose in the hose gland strain-relieved?
- ▶ Have the bottles with reagents, and standard been inserted and connected?
- ▶ Inspect the hose connections. Use the hose connection diagram as a guide.

9.3 Switching ON the measuring device

- ▶ Switch on the supply voltage. Wait for initialization.

9.4 Setting the operating language

Configure language

- ▶ Press the soft key **MENU**. Set your language in the top menu item.
 - ↳ The device can now be operated in your chosen language.

9.5 Configuring the measuring device

9.5.1 Basic setup analyzer

Making basic settings

1. Go to the menu **Setup/Basic setup analyzer**.
 - ↳ Make the following settings.
2. **Device tag**: Give your device any name of your choice (max. 32 characters).
3. **Set date**: Correct the set date if necessary.
4. **Set time**: Correct the set time if necessary.
5. Return to measuring mode by pressing and holding the soft key for **ESC** for at least one second.
 - ↳ Your analyzer now works with your basic settings. The sensors connected use the factory settings of the sensor type in question and the individual calibration settings that were last saved.

If you wish to configure your most important input and output parameters in the **Basic setup analyzer** :

- ▶ Configure the current inputs, relays, limit switches, cleaning cycles and device diagnostics with the following submenus.

9.5.2 Starting commissioning

Starting initial commissioning

- ▶ Start initial commissioning of the analyzer under **Menu/Operation /Maintenance/Commissioning/Start commissioning**

10 Operation

10.1 General settings

10.1.1 Basic settings

Menu/Setup/General settings		
Function	Options	Info
Temperature unit	Selection <ul style="list-style-type: none"> ▪ °C ▪ °F ▪ K Factory setting °C	
Current output range	Selection <ul style="list-style-type: none"> ▪ 0..20 mA ▪ 4..20 mA Factory setting 4..20 mA	In accordance with Namur NE43, the linear range is from 3.8 to 20.5 mA (4..20 mA) or from 0 to 20.5 mA (0..20 mA). If the range is exceeded or undershot, the current value stops at the range limit and a diagnostic message (460 or 461) is output.
Error current	0.0 to 23.0 mA Factory setting 22.5 mA	The function meets NAMUR NE43. Set the current value that should be output at the current outputs in the event of an error.
 The value for Error current should be outside the measuring range. If you decided that your Current output range = 0..20 mA you should set an error current between 20.1 and 23 mA. If the Current output range = 4..20 mA you could also define a value < 4 mA as the error current. The device allows an error current within the measuring range. In such instances pay attention to possible affects this may have on your process.		
Alarm delay	0 to 9999 s Factory setting 0 s	The system only displays the errors that are present longer than the set delay time. This makes it possible to suppress messages that only occur briefly and are caused by normal process-specific fluctuations.
Device hold	Selection <ul style="list-style-type: none"> ▪ Disabled ▪ Enabled Factory setting Disabled	You can enable an immediate, general hold (for sensors) here. The function acts in the same way as the HOLD soft key in the screens.

10.1.2 Date and time

Menu/Setup/General settings/Date/Time		
Function	Options	Info
Set date	Depends on the format	Editing mode: Day (two-digit): 01 to 31 Month (two-digit): 01 to 12 Year (four-digit): 1970 to 2106
Set time	Depends on the format	Editing mode: hh (hour): 00 to 23 / 0 am to 12 pm mm (minutes): 00 to 59 ss (seconds): 00 to 59

Menu/Setup/General settings/Date/Time		
Function	Options	Info
▶ Extended setup		
Date format	Selection <ul style="list-style-type: none"> ▪ DD.MM.YYYY ▪ YYYY-MM-DD ▪ MM-DD-YYYY Factory setting DD.MM.YYYY	Decide which date format you want to use.
Time format	Selection <ul style="list-style-type: none"> ▪ HH:MM am (12h) ▪ HH:MM (24h) ▪ HH:MM:SS (24h) Factory setting HH:MM:SS (24h)	Decide whether you want to use the 12-hour or 24-hour clock. Seconds can also be displayed with the latter version.
Time zone	Selection <ul style="list-style-type: none"> ▪ None ▪ Choice of 35 time zones Factory setting None	None = Greenwich Mean Time (London).
DST	Selection <ul style="list-style-type: none"> ▪ Off ▪ Europe ▪ USA ▪ Manual Factory setting Off	The controller adapts the summertime/normal time changeover automatically if you choose European or American daylight saving time. Manual means that you can specify the start and end of daylight saving time yourself. Here, two additional submenus are displayed in which you specify the changeover date and time.

10.1.3 Hold settings

Menu/Setup/General settings/Hold settings		
Function	Options	Info
Settings automatic Hold		
Hold release time	0 to 600 s Factory setting 0 s	The hold status is maintained for the duration of the delay time when you switch to the measuring mode.
Setup menu	Selection <ul style="list-style-type: none"> ▪ Disabled ▪ Enabled Factory setting Disabled	Decide whether the device outputs should switch to the defined hold state when the particular menu is opened.
Diagnostics menu		
Calibration active	Factory setting Enabled	
External hold	Selection <ul style="list-style-type: none"> ▪ Disabled ▪ Enabled Factory setting Disabled	

10.1.4 Logbooks

Logbooks record the following events:

- Calibration/adjustment events
- Operator events
- Diagnostic events

You define how the logbooks should store the data.

In addition, you can also define individual data logbooks for sensors.

1. Assign the logbook name.
2. Select the measured value to be recorded.
3. Set the recording rate (**Scan time**).
 - ↳ You can set the recording rate individually for every data logbook.



Further information on the logbooks: .

Data logbooks only apply for sensors (optional). There are special data logbooks for the analyzer. These logbooks are automatically enabled and assigned to the measuring channel.

SP1: Data logbook SP1 is assigned to measuring channel 1 of the analyzer.

Menu/Setup/General settings/Logbooks		
Function	Options	Info
Logbook ident	Customized text, 16 characters	Part of the file name when exporting a logbook
Event logbook	Options <ul style="list-style-type: none"> ▪ Off ▪ Ring buffer ▪ Fill up buffer Factory setting Ring buffer	All diagnostic messages are recorded Ring buffer If the memory is full, the most recent entry automatically overwrites the oldest entry. Fill up buffer If the memory is full, there is an overflow, i.e. no new values can be saved. The controller displays a corresponding diagnostic message. The memory then has to be cleared manually.
Analyzer event logbook	Options <ul style="list-style-type: none"> ▪ Ring buffer ▪ Fill up buffer Factory setting Ring buffer	All diagnostic messages are recorded Ring buffer If the memory is full, the most recent entry automatically overwrites the oldest entry. Fill up buffer The device displays a diagnostic message when the memory is 80% full. If the memory is full, there is an overflow, i.e. no new values can be saved. The controller displays a corresponding diagnostic message. The memory then has to be cleared manually.
► Overflow warnings Analyzer calibration logbook = Fill up buffer		
Calibration logbook	Options <ul style="list-style-type: none"> ▪ Off ▪ On Factory setting Off	Decide whether you want to receive a diagnostic message if the fill-up buffer of the relevant logbook overruns.
Diagnostic logbook		
Configuration logbook		
Analyzer data logbooks		For analyzer measured data The entry is made automatically on completion of the measurement. A setting does not need to be made. The logbook is activated automatically. SP1 is assigned to data logbook SP1.

Menu/Setup/General settings/Logbooks		
Function	Options	Info
▶ Data logbook SP1		Assignment to measuring channel
Source of data	Read only	The assigned measuring channel is displayed
Measuring parameter	Read only	Plain-text information on the parameter that is being recorded
Unit	Read only	Information about the unit in which the data are available.
Logbook name	Customized text, 16 characters	
▶ Line plotter		Menu to define the graphic display
Axes	Options <ul style="list-style-type: none"> ▪ Off ▪ On Factory setting On	Should the axes (x, y) be displayed (On) or not (Off)?
Orientation	Options <ul style="list-style-type: none"> ▪ Horizontal ▪ Vertical Factory setting Horizontal	You can choose whether the value curves should be displayed from left to right (Horizontal) or from top to bottom (Vertical). If you want to display two data logbooks simultaneously, make sure that both logbooks have the same settings here.
X-Description	Options <ul style="list-style-type: none"> ▪ Off ▪ On Factory setting On	Decide whether a description should be displayed for the axes and whether gridlines should be shown. In addition, you can also decide whether pitches should be displayed.
Y-Description		
Grids		
Pitches		
X Pitch/Grid distance	10 to 50%	Specify the pitches.
Y Pitch/Grid distance	10 %	
▶ Data logbooks		For connected Memosens sensors (optional)
▶ New		You can create a maximum of 8 data logbooks.
Logbook name	Customized text, 20 characters	
Source of data	Options <ul style="list-style-type: none"> ▪ Sensor inputs ▪ Controller ▪ Current inputs ▪ Temperature ▪ Fieldbus signals ▪ Mathematical functions Factory setting None	Select a data source for the logbook entries. You can choose from connected sensors, available controllers, current inputs, fieldbus signals, binary input signals and mathematical functions.
Measured value	Options depend on Source of data Factory setting None	You can record different measured values depending on the data source.

Menu/Setup/General settings/Logbooks		
Function	Options	Info
Scan time	0:00:01 to 1:00:00 Factory setting 0:01:00	Minimum interval between two entries Format: H:MM:SS
Data logbook	Options ▪ Ring buffer ▪ Fill up buffer Factory setting Ring buffer	Ring buffer If the memory is full, the most recent entry automatically overwrites the oldest entry. Fill up buffer If the memory is full, there is an overflow, i.e. no new values can be saved. The controller displays a corresponding diagnostic message. The memory then has to be cleared manually.
Overflow warnings Data logbook = Fill up buffer	Options ▪ Off ▪ On Factory setting Off	Decide whether you want to receive a diagnostic message if the fill-up buffer of the relevant logbook overruns.
▷ Add another logbook	Action	Only if you want to create another data logbook immediately. You add a new data logbook at a later date using New .
▷ Finished	Action	This allows you to exit the menu New .
▷ Start/stop simultaneously	Action	Appears if you have created more than one data logbook. With one mouse click, you can start or stop recording all the data logbooks.
▶ Logbook name		The name of this submenu is based on the name of the logbook and only appears once you have created a logbook.
 This menu appears several times if you have several data logbooks.		
Source of data	Read only	This is for information purposes only. If you want to record another value, delete this logbook and create a new data logbook.
Measured value		
Log time left Data logbook = Fill up buffer	Read only	Displays the days, hours and minutes remaining until the logbook is full.
Log size Data logbook = Fill up buffer	Read only	Displays the number of entries remaining until the logbook is full.
Logbook name	Customized text, 20 characters	You can change the name here again.
Scan time	0:00:01 to 1:00:00 Factory setting 0:01:00	As above Minimum interval between two entries Format: H:MM:SS
Data logbook	Options ▪ Ring buffer ▪ Fill up buffer Factory setting Ring buffer	Ring buffer If the memory is full, the most recent entry automatically overwrites the oldest entry. Fill up buffer If the memory is full, there is an overflow, i.e. no new values can be saved. The controller displays a corresponding diagnostic message. The memory then has to be cleared manually.
Overflow warnings Data logbook = Fill up buffer	Options ▪ Off ▪ On Factory setting Off	Decide whether you want to receive a diagnostic message if the fill-up buffer of the relevant logbook overruns.

Menu/Setup/General settings/Logbooks		
Function	Options	Info
▶ Line plotter		Menu to define the graphic display
Axes	Options <ul style="list-style-type: none"> ▪ Off ▪ On Factory setting On	Should the axes (x, y) be displayed (On) or not (Off)?
Orientation	Options <ul style="list-style-type: none"> ▪ Horizontal ▪ Vertical Factory setting Horizontal	You can choose whether the value curves should be displayed from left to right (Horizontal) or from top to bottom (Vertical). If you want to display two data logbooks simultaneously, make sure that both logbooks have the same settings here.
X-Description	Options <ul style="list-style-type: none"> ▪ Off ▪ On Factory setting On	Decide whether a description should be displayed for the axes and whether gridlines should be shown. In addition, you can also decide whether pitches should be displayed.
Y-Description		
Grids		
Pitches		
X Pitch/Grid distance	10 to 50%	Specify the pitches.
Y Pitch/Grid distance	Factory setting 10 %	
▷ Remove	Action	This action removes the data logbook. Any data that have not been saved are lost.



Example: New data logbook (Setup/General settings/Logbooks/Data logbooks/New)

1. Make the settings:
 - Logbook name
Assign a name. Example: "01".
 - Source of data
Select a data source. Example: Signal of binary input 1.
 - Measured value
Select the measured value to be recorded. Example: pH value.
 - Scan time
Specify the time interval between two logbook entries.
 - Data logbook
Activate the logbook: specify the data storage method.
2. Run the **../Finished:** action.
 - ↳ The device shows the new logbook in the list of data logbooks.
3. Select data logbook "01".
 - ↳ Additional display: **Log time left**.
4. Only for **Fill up buffer:**
 - Choose **Overflow warning: On** or **Off**.
 - ↳ **On:** The device displays a diagnostic message in the event of memory overflow.
5. Submenu **Line plotter:** Specify the type of graphic representation.

10.1.5 Advanced setup

Diagnostics settings

The list of diagnostic messages displayed depends on the path selected. There are device-specific messages, and messages that depend on what sensor is connected.

Menu/Setup/(General settings or Inputs<Sensor channel>)/Extended setup/Diagnostics settings/Diag. behavior		
Function	Options	Info
List of diagnostic messages		Select the message to be changed. Only then can you make the settings for this message.
Diag. code	Read only	
Diagnostic message	Selection <ul style="list-style-type: none"> ▪ On ▪ Off Factory setting Depends on the message	You can deactivate or reactivate a diagnostic message here. Deactivating means: <ul style="list-style-type: none"> ▪ No error message in the measuring mode ▪ No error current at the current output
Error current	Selection <ul style="list-style-type: none"> ▪ On ▪ Off Factory setting Depends on the message	Decide whether an error current should be output at the current output if the diagnostic message display is activated.  In the event of general device errors, the error current is output at all the current outputs. In the event of channel-specific errors, the error current is only output at the assigned current output.
Status signal	Selection <ul style="list-style-type: none"> ▪ Maintenance (M) ▪ Out of specification (S) ▪ Function check (C) ▪ Failure (F) Factory setting Depends on the message	The messages are divided into different error categories in accordance with NAMUR NE 107. Decide whether you want to change a status signal assignment for your application.
Diag. output	Selection <ul style="list-style-type: none"> ▪ None ▪ Alarm relay ▪ Binary output ▪ Relay 1 to n (depends on the device version) Factory setting None	Before being able to assign the message to an output you must first configure a relay output to Diagnostics . (Menu/Setup/Outputs : Assign the Diagnostics function and set the Operating mode to as assigned .)
 An alarm relay is always available, regardless of the device version. Other relays are optional.		
Cleaning program (for sensors)	Selection <ul style="list-style-type: none"> ▪ None ▪ Cleaning 1 ▪ Cleaning 2 ▪ Cleaning 3 ▪ Cleaning 4 Factory setting None	Decide whether the diagnostic message should trigger a cleaning program. You can define the cleaning programs under: Menu/Setup/Additional functions/Cleaning .
Detail information	Read only	Here you can find more information on the diagnostic message and instructions on how to resolve the problem.

PROFIBUS DP

Menu/Setup/General settings/Extended setup/PROFIBUS		
Function	Options	Info
Enable	Selection <ul style="list-style-type: none"> ▪ Off ▪ On Factory setting On	You can switch off communication at this point. The software can then only be accessed via local operation.
Termination	Read only	If the device is the last in the bus, you can terminate via the hardware.
Bus address	1 to 125	If you have addressed the bus via hardware (DIP switches on the module,), you can only read the address here. If an invalid address is set via the hardware, you have to assign a valid address for your device either here or via the bus.
Ident number	Selection <ul style="list-style-type: none"> ▪ Automatic ▪ PA-Profile 3.02 (9760) ▪ Manufacturer specific Factory setting Automatic	

Modbus

Menu/Setup/General settings/Extended setup/Modbus		
Function	Options	Info
Enable	Selection <ul style="list-style-type: none"> ▪ Off ▪ On Factory setting On	You can switch off communication at this point. The software can then only be accessed via local operation.
Termination	Read only	If the device is the last in the bus, you can terminate via the hardware.
Settings		
Transmission Mode	Selection <ul style="list-style-type: none"> ▪ TCP ▪ RTU ▪ ASCII Factory setting (Modbus-RS485 only) RTU	The transmission mode is displayed depending on the version ordered. In the case of RS485 transmission, you can choose between RTU and ASCII . There are no choices for Modbus-TCP.
Byte order	Selection <ul style="list-style-type: none"> ▪ 1-0-3-2 ▪ 0-1-2-3 ▪ 2-3-0-1 ▪ 3-2-1-0 Factory setting 1-0-3-2	
Watchdog	0 to 999 s Factory setting 5 s	If no data transmission takes place for longer than the time set, this is an indicator that communication has been interrupted. After this time, input values received via the Modbus are considered to be invalid.

Web server

Menu/Setup/General settings/Extended setup/Webserver		
Function	Options	Info
Webserver	Selection <ul style="list-style-type: none"> ▪ Off ▪ On Factory setting On	You can switch off communication at this point. The software can then only be accessed via local operation.
Webserver TCP Port 80	Read only	The Transmission Control Protocol (TCP) is an arrangement (protocol) as to how data should be exchanged between computers. A port is a part of an address which assigns data segments to a network protocol.
Webserver login	Selection <ul style="list-style-type: none"> ▪ Off ▪ On Factory setting On	You can switch user administration on and off at this point. This makes it possible to create multiple users with password access.
User administration		
List of users already created	View/edit	You can change user names or passwords or delete users. A user is already created at the factory: "admin" with password "admin".
New user:		
Name	Free text	Create new user <ol style="list-style-type: none"> 1. Press INSERT. 2. Assign any name to the new user. 3. Select a password for the user. 4. Confirm the password. ↳ You can now change the password at any time.
Enter new user password	Free text	
Confirm new user password	Free text	
Change user password	Free text	

EtherNet/IP

Menu/Setup/General settings/Extended setup/Ethernet		
Function	Options	Info
Enable	Selection <ul style="list-style-type: none"> ■ Off ■ On Factory setting On	You can switch off communication at this point. The software can then only be accessed via local operation.
Settings		
Link settings	Selection <ul style="list-style-type: none"> ■ Auto negotiation ■ 10MBps Half duplex ■ 10MBps Full duplex ■ 100MBps Half duplex ■ 100MBps Full duplex Factory setting Auto negotiation	Transmission methods of the communication channels <ul style="list-style-type: none"> ■ Full duplex: Data can be transmitted simultaneously in both directions. ■ Half-duplex: Data can only be transmitted alternately in both directions, i.e. not at the same time. Source: Wikipedia
DHCP	Selection <ul style="list-style-type: none"> ■ Off ■ On Factory setting On	The Dynamic Host Configuration Protocol (DHCP) makes it possible to assign the network configuration to clients via a server. With DHCP, it is possible to automatically integrate the device into an existing network without the need for manual configuration. Normally only the automatic assignment of the IP address must be configured at the client. During startup, the IP address, the netmask and the gateway are retrieved from a DHCP server.  Do you want to assign the IP address of the device manually? If so, you must set DHCP = Off .
IP-Address	xxx.xxx.xxx.xxx	An IP address is an address in computer networks which are based on the Internet protocol (IP). You can only set the IP address if DHCP is switched off.
Netmask	xxx.xxx.xxx.xxx	On the basis of the IP address of a device, the netmask specifies which IP addresses this device searches for in its own network and which addresses it could access in other networks via a router. It therefore divides the IP address into a network part (network prefix) and a device part. The network part must be identical for all devices in the individual network, and the device part must be different for every device within the network.
Gateway	x.x.x.x	A gateway (protocol converter) enables communication between networks that are based on completely different protocols.
Service switch	Read only	
MAC-Address	Read only	The MAC address (Media Access Control address) is the hardware address of every individual network adapter which is used to uniquely identify the device in a computer network.
EtherNetIP Port 44818	Read only	A port is a part of an address which assigns data segments to a network protocol.

Accepting settings

Have you changed settings manually, such as the IP address?

- ▶ Before you leave the **Ethernet** menu:
 - Select **SAVE** to apply your settings.
 - ↳ In the **DIAG/System information** menu you can check whether the new settings are used.

Data management

Firmware update

 Please contact your local sales office for information on firmware updates available for your controller and its compatibility with earlier versions.

The **current firmware version** of the analyzer, FXAB1 control module, photometer and sample preparation 1 can be found at: **Menu/Diagnostics/System information/**.

 Back up your current setup and your logbooks to an SD card.

To install a firmware update, you must have the update available on an SD card.

1. Insert the SD card into the controller card reader.
2. Go to: **Menu/Setup/General settings/Extended setup/Data management/Firmware update**.
 - ↳ The update files on the SD card are displayed.
3. Select the desired update and select yes when the following question is displayed:

The current firmware will be overwritten.
After this the device will reboot.
Do you want to proceed?

 - ↳ The firmware is loaded and the device is then started with the new firmware.

Saving the setup

Saving the setup gives you the following advantages:

- Copying settings for other devices
- Quick and easy switching between various setups, e.g. for different user groups or for recurring sensor type change
- Restoring a tried-and-tested setup, e.g. if you have changed a lot of settings and no longer know what the original settings were

1. Insert the SD card into the controller card reader.
2. Go to: **Menu/Setup/General settings/Extended setup/Data management/Save setup**.
3. **Name:** Assign a file name.
4. Then select **Save**.
 - ↳ If you have already assigned the file name, you will be asked whether you want to overwrite the existing setup.
5. Select **OK** to confirm, or cancel the operation and assign a new file name.
 - ↳ Your setup is stored on the SD card and you can upload it quickly to the device at a later date.

Loading the setup

When you load a setup, the current configuration is overwritten.

Note that cleaning and controller programs could be active. Do you want to continue anyway?

1. Insert the SD card into the controller card reader. A setup must have been saved to the SD card.
2. Go to: **Menu/Setup/General settings/Extended setup/Data management/Load setup**.
 - ↳ A list of all the setups on the SD card is displayed.
An error message is displayed if there is no valid setup on the card.
3. Select the desired setup.
 - ↳ A warning is displayed:
The current parameters will be overwritten and the device will reboot.
Warning: Please note that cleaning and controller programs can be active.
Do you want to proceed?
4. Select **OK** to confirm, or cancel the operation.
 - ↳ If you select **OK** to confirm, the device restarts with the desired setup.

Exporting the setup

Exporting the setup offers the following advantages:

- Export in XML format with a stylesheet for formatted display in an XML-compatible application such as Microsoft Internet Explorer
- Importing the data (drag and drop the XML file into a browser window)

1. Insert the SD card into the controller card reader.
2. Go to: **Menu/Setup/General settings/Extended setup/Data management/Export setup**.
3. **Name**: Assign a file name.
4. Then select **Export**.
 - ↳ If you have already assigned the file name, you will be asked whether you want to overwrite the existing setup.
5. Select **OK** to confirm, or cancel the operation and assign a new file name.
 - ↳ Your setup is saved on the SD card in the "Device" folder.

 You cannot upload the exported setup to the device again. You must use the **Save setup** function for this purpose. This is the only way you can save a setup to an SD card and reload it later on or upload it to other devices.

Activation code

You require activation codes for:

- Additional functions, e.g. fieldbus communication
- Firmware upgrades

 If activation codes are available for your device, these codes are provided on the inner nameplate. The corresponding device functions are activated at the factory. You only require the codes if servicing the device.

1. Enter the activation code: **Menu/Setup/General settings/Extended setup/Data management/Activation code**.
2. Confirm your entry.
 - ↳ Your new hardware or software function is activated and can be configured.

The table below tells you what functions an activation code enables:

Function	Activation code beginning with
Two current outputs (BASE-E module only)	081...
HART	0B1...
PROFIBUS PA	0B2...
PROFIBUS DP	0B3...
Modbus TCP	0B4...
Modbus RS485	0B5...
EtherNet/IP	0B6...
Cooling ²⁾	0F1...
Measuring range switching, set 1	211...
Measuring range switching, set 2 ¹⁾	212...
Feedforward control	220...
Chemoclean Plus	25...
Collecting vessel ²⁾	20...
Measuring channels ²⁾	28...
Mathematical function Cation exchanger capacity	301...

- 1) When you order the "Measuring range switching" option, you receive two activation codes. Enter both codes to have two sets for measuring range switching.
- 2) Availability depends on measuring parameter

Change password

You can lock the operating keys with a password (access the context menu by pressing the navigator for longer). The keys can then only be enabled by entering the right password.

Set the password to lock the keys here: **Menu/Setup/General settings/Extended setup/Data management/Change lock password**.

1. Enter the current password (factory setting 0000).
 - ↳ Enter new lock password
2. Enter a new password.
 - ↳ Confirm new lock password
3. Enter the new password again.
 - ↳ The lock password has been changed successfully.

Press the navigator for longer to return to the measuring mode.

10.2 Analyzer

Menu/Setup/Analyzer		
Function	Options	Info
Mode	Read only	Manual, automatic or fieldbus
Device tag	Customized text, 32 characters Factory setting Analyzer_serial number	Select any name for your analyzer. Use the TAG name for example.
Meas. param	Read only	
Measuring range	Read only	

10.2.1 Advanced setup

Menu/Setup/Analyzer/Extended setup		
Function	Options	Info
▶ Measuring value		
Main value	Options Fe Factory setting Fe	
Unit	Options <ul style="list-style-type: none"> ▪ mg/l ▪ µg/l ▪ ppm ▪ ppb Factory setting mg/l or µg/l	
Main value format	Options <ul style="list-style-type: none"> ▪ # ▪ #.# ▪ #.## ▪ Auto Factory setting #.#	
▶ Signal for sample request		
Lead time SP% ^{C 1)}	Options 0.00 to 30.00 (MM:SS) Factory setting 0.00 (MM:SS)	In the automatic mode, each measurement only starts once the lead time has elapsed. The request sample signal is active from the start of the lead time until the end of the specified signal duration time.
Duration SP% ^{C 1)}	Options 0:00 to 60:00 (MM:SS) Factory setting 3:00 (MM:SS)	You can set the duration for which the signal is active.
▶ Signal for process access		
SP1	Options <ul style="list-style-type: none"> ▪ Always accessible ▪ Binary input x:y Factory setting Always accessible	Always accessible: The input signal level at the binary inputs does not affect actions that require sample (measurement, calibration, cleaning). Binary input x:y: When the signal is active at the selected input, the analyzer starts actions where sample is absolutely required. Otherwise the analyzer defers or skips the action. In the case of two-channel devices SP2 is also displayed.
▶ Diagnostics settings		
▶ Limits dispensers		
Control	Options <ul style="list-style-type: none"> ▪ Off ▪ On Factory setting On	
▶ Warning limit		
Remaining operating time	Read only	
Dispenser 2, Dispenser 3, Dispenser 7	Options 1 to 90 (d) Factory setting 28 d	

Menu/Setup/Analyzer/Extended setup		
Function	Options	Info
Diag. code 733	Read only	
▶ Alarm limit		
Remaining operating time	Options 1 to 60 (d) Factory setting 7 d	
Diag. code 732	Read only	
▶ Bottles		
Control	Options <ul style="list-style-type: none"> ▪ Off ▪ On Factory setting Off	
▶ Bottle filling levels		
▶ Start volume		
Standard S1	Options 100 to 1000 ml Factory setting <ul style="list-style-type: none"> ▪ 1000 ml 	
Reagent RK	Options 100 to 1000 ml Factory setting 1000 ml	
▶ Warning limits		
Standard S1	Options 1 to 20 % Factory setting 2 %	
Reagent RK	Options 1 to 40 % Factory setting 10 %	
Diag. code 726	Read only	
▶ Alarm limits		
Standard S1	Options 1 to 20 % Factory setting 2 %	

Menu/Setup/Analyzer/Extended setup		
Function	Options	Info
Reagent RK	Options 1 to 40 % Factory setting 5 %	
▶ Absorption curve recording		
In automatic mode	Options <ul style="list-style-type: none"> ▪ Off ▪ On Factory setting Off	Off: Recording is only possible in the manual mode On: Recording also takes place in the automatic mode
Curve	Options 1 to 7 Factory setting 2	Select the absorption curve to be recorded. Only one curve can be selected at any one time. The data are saved in a logbook.
After power failure	Options <ul style="list-style-type: none"> ▪ Last mode ▪ Manual mode Factory setting Last mode	Setting specifying how the analyzer should behave after a power failure, and when the power is back on. Last mode: The analyzer remains in the mode that was last set. Example: The automatic mode was set. The analyzer continues after initialization and after any samples have been discarded. Manual mode: The analyzer switches to the manual mode and waits for user action.

- 1) "%C" stands for context-dependent text that is automatically generated by the software. This then contains the name of the sample preparation, e.g. "1" or "2".

10.2.2 Measurement

Menu/Setup/Analyzer/Measurement		
Function	Options	Info
Start condition	Options <ul style="list-style-type: none"> ▪ Immediate ▪ Date/time ▪ Continuous Factory setting Immediate	Immediate: The analyzer immediately starts with the measurement cycle once the system changes to the automatic mode. Date/time: The analyzer starts with the measurement cycle at the set date/time. Continuous: The analyzer measures continuously, without interruption, between the measurements.
If the start condition selected is Immediate		
Measuring interval	0:10 to 24:00 (HH:MM) Factory setting 0:10	For configuring the time interval of the measurement
If the start condition selected is Date/time		
Date	01.01.1970 to 07.02.2106 Factory setting DD.MM.YYYY	
Time	00:00:00 to 23:59:59 Factory setting HH:MM:SS (24 h)	
Measuring interval	0:10 to 24:00 (HH:MM) Factory setting 0:10	For configuring the time interval of the measurement

Menu/Setup/Analyzer/Measurement		
Function	Options	Info
▶ Sequence of measurements	Options <ul style="list-style-type: none"> ▪ SP1 ▪ SP2 ▪ Pause 	<p>Is only displayed for a two-channel device.</p> <ul style="list-style-type: none"> ▪ SP1: Indicate the number of consecutive measurements for channel SP1 ▪ SP2: Indicate the number of consecutive measurements for channel SP2 ▪ Pause: If the Pause channel is selected, the analyzer does not run the measurement. <p>Using the softkeys INSERT, DEL and SAVE you can add rows to the table, delete and save them.</p>
Channel change delay	15 to 600 Factory setting 30	Additional delay time which the analyzer waits to elapse after every change of sample.
Signal delay	0 to 600 Factory setting 0	Here you can delay the process of outputting the "Measurement active" signal when a measurement is running by the specified time. Measuring is paused for the duration of the defined signal delay time.

10.2.3 Calibration

Menu/Setup/Analyzer/Calibration		
Function	Options	Info
Start condition	Options <ul style="list-style-type: none"> ▪ Immediate ▪ Date/time Factory setting Immediate	The calibration can start either immediately or on the set date/at the set time.
If the start condition selected is Immediate		
Date	01.01.1970 to 07.02.2106 Factory setting DD.MM.YYYY	
Time	00:00:00 to 23:59:59 Factory setting HH:MM:SS (24 h)	
Calibration interval	0-01 to 90-00 (DD-HH) Factory setting 02-00	For configuring the time interval of the calibration/adjustment.
Next calibration Mode = Automatic	Read only	
Zero point	Read only	
Calibration factor	Read only	Relationship of the measured concentration to the pre-specified concentration of the calibration standard.

Menu/Setup/Analyzer/Calibration		
Function	Options	Info
▶ Settings		
Nominal concentration	0.10 to 5.00 (mg/l) Factory setting 2.0 (based on Fe)	For configuring the concentration of the calibration standard solution. Depends on the settings under Menu/Setup/Analyzer/Extended setup/Measuring value/Main value
Automatic cleaning	Options <ul style="list-style-type: none"> ▪ Off ▪ On Factory setting On	For specifying whether cleaning will take place before every calibration/adjustment (only in the automatic mode).

10.3 Sample preparation

 The menu displayed depends on the connected sample preparation system. The menu item does not appear if a Liquiline System CA80 analyzer without a collecting vessel is connected. The Liquiline System CAT860 can only be operated with a Liquiline System CA80 single-channel device.

Menu/Setup/Sample preparation		
Function	Options	Info
Installation type	Options <ul style="list-style-type: none"> ▪ Others ▪ Pressurized pipe sampling Factory setting Others	Others: e.g. Liquiline System CAT820 / CAT860 Pressurized pipe sampling: Sample preparation that is installed in a pressure pipe, e.g. Liquiline System CAT810.
If the installation type selected is Others :		
▶ Sample preparation 1		In the case of two-channel devices, sample preparation 2 is also displayed.
Operating mode	Options <ul style="list-style-type: none"> ▪ Controlled ▪ Independent Factory setting Controlled	Controlled: Sample preparation which is controlled by the CA80 analyzer, e.g. Liquiline System CAT820 / CAT860 Independent: No sample preparation that is controlled by the Liquiline System CA80 analyzer, e.g. Stamoclean CAT430. The supply of sample must be guaranteed by the customer.
If the operating mode selected is Controlled :		
Tag	Customized text, 32 characters	
Cleaning start condition (CAT860)	Options <ul style="list-style-type: none"> ▪ Immediate ▪ Date/time ▪ Disabled 	Immediate: Cleaning starts immediately. Date/time: Cleaning starts at the selected date/time. Disabled: Cleaning is not active.
If the start condition selected is Immediate or Date/time :		
Cleaning interval (CAT860)	Options <ul style="list-style-type: none"> ▪ 0-01 to 90-00 (DD-HH) ▪ Factory setting 0-01	Compressed air or water cleaning for longer filter maintenance intervals. Cleaning with liquid cleaner.

Menu/Setup/Sample preparation		
Function	Options	Info
If the start condition selected is Date/time :		
Date (CAT860)	Options <ul style="list-style-type: none"> ▪ 01.01.1970 to 07.02.2106 DD.MM.YYYY ▪ Factory setting 01.01.1970	
Time (CAT860)	Options <ul style="list-style-type: none"> ▪ 00:00:00 to 23:59:59 HH:MM:SS ▪ Factory setting 00:00:00	
Residence time (CAT860)	Options <ul style="list-style-type: none"> ▪ 0:30 to 20:00 (MM:SS) ▪ Factory setting 1:00	Reaction time of cleaner during the cleaning
►Sampling pump interval (CAT820, CAT860)		
Pump time	Options 10 to 20 s Factory setting 10 s	Ratio between the pumping duration and the pumping interval of the peristaltic pump. This affects the volume of the pumped sample.
Pump pause	Options <ul style="list-style-type: none"> ▪ 20 to 50 s Factory setting 30 s	
►Pressurized air cleaning (CAT820, CAT860)		
Compressed air (CAT820)	Options <ul style="list-style-type: none"> ▪ Available ▪ Not available Factory setting Depends on the device version	Settings for sample preparation with or without compressed air cleaning. In the event of retrofitting, the compressed air can be activated here.
Cleaning mode	Options <ul style="list-style-type: none"> ▪ On ▪ Off Factory setting On	Activates or deactivates automatic compressed air cleaning of the pump-to-filter hose and of the filter.
Cleaning interval	Options 0:30 to 4:00 HH:MM Factory setting 2:00	Cleaning interval of the automatic compressed air cleaning system
Cleaning duration	Options 10 to 60 s Factory setting 30 s	Cleaning duration of the automatic compressed air cleaning system
►Heatings (CAT820, CAT860)		

Menu/Setup/Sample preparation		
Function	Options	Info
Cabinet	Options <ul style="list-style-type: none"> ▪ Available ▪ Not available Factory setting Depends on the device version	In the event of retrofitting, the heating can be activated here.
Hose filter	Options <ul style="list-style-type: none"> ▪ Available ▪ Not available Factory setting Depends on the device version	In the event of retrofitting, the heating can be activated here.
Hose analyzer	Options <ul style="list-style-type: none"> ▪ Available ▪ Not available Factory setting Depends on the device version	In the event of retrofitting, the heating can be activated here.
▶Diagnostics settings		
▶ Limit change filter (CAT820, CAT860)		
Function	Options <ul style="list-style-type: none"> ▪ On ▪ Off Factory setting Off	
Diag. code 729	Read only	
Warning limit	Options 01-00 to 99-00 (DD-HH) Factory setting 60-00	
▶ Limit change hose (CAT820, CAT860)		
Function	Options <ul style="list-style-type: none"> ▪ On ▪ Off Factory setting On	
Diag. code 337	Read only	
Warning limit	Options 01-00 to 99-00 (DD-HH) Factory setting 60-00	
▷ Reset settings		Resets all settings specific to sample preparation. All other settings are retained.
If the installation type selected is Pressurized pipe sampling (with Liquiline System CAT810 for instance):		
▶ Sample preparation 1		In the case of two-channel devices, sample preparation 2 is also displayed.
Cleaning valve	Options <ul style="list-style-type: none"> ▪ Available ▪ Not available Factory setting Not available	In the event of retrofitting, the valve can be activated here.
If the option selected for the cleaning valve is Available		

Menu/Setup/Sample preparation		
Function	Options	Info
Filter backflush	Options <ul style="list-style-type: none"> ■ On ■ Off Factory setting On	
If the option selected for filter backflush is On :		
Cleaning interval	Options 00:10 to 02:00 HH:MM Factory setting 00:30	Compressed air or water cleaning (optional) for longer filter maintenance intervals.
Cleaning duration	Options 10 to 30 s Factory setting 10 s	Cleaning duration of the automatic water or compressed air cleaning system
Cleaning discard time	Options 0 to 1800 s Factory setting 180 s	Discard time once cleaning is complete. If water is used as the flushing medium, this must be replaced by a fresh sample before starting the next measurement.
▷ Reset settings		Resets all settings specific to sample preparation. All other settings are retained.

10.4 Current inputs

The input can be used as the data source for limit switches and logbooks, for example. Furthermore, external values can be made available as set points for controllers.

Menu/Setup/Inputs/Current input x:y ¹⁾		
Function	Options	Info
Mode	Selection <ul style="list-style-type: none"> ■ Off ■ 0 - 20mA ■ 4 - 20mA Factory setting 4 - 20mA	Select the same current range as in the data source (connected device).
Input mode	Selection <ul style="list-style-type: none"> ■ Parameter ■ Current Factory setting Current	Select the input variable.
Meas. value format	Selection <ul style="list-style-type: none"> ■ # ■ #.# ■ #.## ■ #.### Factory setting #.#	Specify the number of decimal places.
Parameter name Input mode = Parameter	Customized text, 16 characters	Assign a useful name, such as the parameter name, which the data source uses.
Unit of measure Input mode = Parameter	Customized text, 16 characters	You cannot choose the unit from a list. If you want to use a unit, you must enter it here as customized text.

Menu/Setup/Inputs/Current input x:y ¹⁾		
Function	Options	Info
Lower range value Input mode = Parameter	-20.0 ... Upper range value <unit of measure> Factory setting 0.0 <engineering unit>	Enter the measuring range. The lower and upper range values are assigned to the 0 or 4 mA value and the 20 mA value respectively. The system uses the engineering unit which you entered beforehand.
Upper range value Input mode = Parameter	Lower range value to 10000.0 <engineering unit> Factory setting 10.0 <engineering unit>	
Damping	0 to 60 s Factory setting 0 s	The damping causes a floating average curve of the measured values over the time specified.

1) x:y = slot no. : input number

10.5 Binary inputs and outputs

Hardware options, such as the "DIO" module with 2 digital inputs and 2 digital outputs or fieldbus module "485" enable the following:

- Via a digital input signal
 - measuring range switching for conductivity (upgrade code required,)
 - switching between different calibration datasets in the case of optical sensors
 - external hold (for sensors)
 - a cleaning interval to be triggered (for sensors)
 - measurements to be started, interruption of measuring intervals
 - PID controller switch-on/switch-off, e.g. via the proximity switch of the CCA250
 - the use of the input as an "analog input" for pulse-frequency modulation (PFM)
- Via a digital output signal
 - diagnostic states, point level switches, "Active measurement" system state, "Sample required" information or similar states transmitted statically (similar to a relay)
 - the dynamic transmission (comparable to a non-wearing "analog output") of PFM signals, e.g. to control dosing pumps

10.5.1 Application examples

Chlorine control with feedforward control

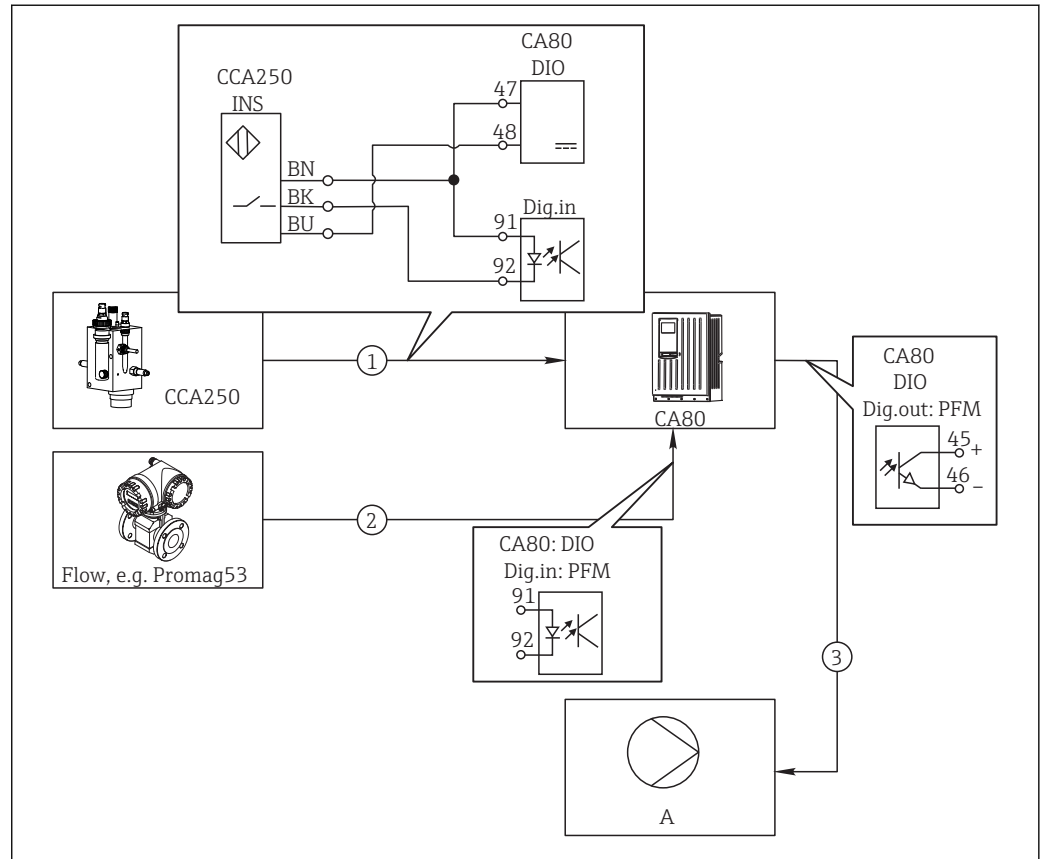

61 Example of chlorine control with feedforward control

- 1 Connection of the inductive proximity switch INS of CCA250 to the digital input of the DIO module
 - 2 Connection of the signal from a flowmeter to the digital input of the DIO module
 - 3 Activation of a (pulse) dosing pump via the digital output of the DIO module
- A Dosing pump

Utilize the advantage of the effectively wear-free control with binary outputs versus a control system with relay. With pulse frequency modulation (PFM), it is possible to achieve virtually continuous dosing using a dosing pump with higher input frequency.

1. Connect the proximity switch INS of the CCA250 assembly to a digital input of the DIO module (e.g. slot 6, port 1).
2. Configure a controller in the software and for the source select the binary input (e.g. **Binary input 1**) to which the proximity switch is connected. (**Menu/Additional functions/Controllers/Controller 1/Controller Enable = Binary input 1**)
3. **Signal type:** For the selected input, select the factory setting (**Static signal**).
4. Connect the measured value of a flowmeter to the second input of the DIO module (e.g. slot 6, port 2).
5. **Signal type:** for this input, select **PFM**. (**Menu/Inputs/Binary input 6:2/Signal type = PFM**)
6. **Input mode:** select the corresponding measured value (**Flow rate**).
 - ↳ You can now use the input you have just configured as the disturbance variable for your controller ¹⁾.

1) An activation code, Order No. 71211288, is necessary for the "feedforward control" function.

7. **Disturbance variable:** In the controller menu, select the binary input to which the flow measured value is connected. (**Menu/Additional functions/Controllers/Controller 1/Disturbance variable/Source of data = Binary input 6:2 and Measured value = PFM value**)
8. You can activate a dosing pump through PFM via a digital output of the DIO module. Connect the pump to an output of the DIO module (e.g. slot 6, port 1) and choose the following settings in the menu: **Menu/Outputs/Binary output 6:1/Signal type = PFM and Source of data = Controller 1.**

Take the direction of action of your dosing into account. Select the correct parameter (**Actuator type = Unipolar+ or Unipolar-**).

You must make additional settings in the controller menu to fully customize the control to suit your process conditions.

CA80 as the cleaning master for connected sensors (optional)

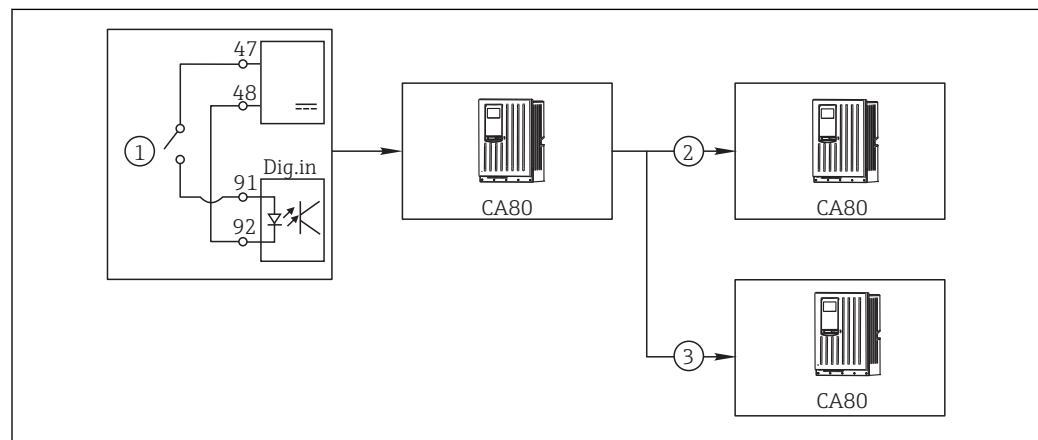

A0029241

62 Example of a central cleaning control

- 1 External cleaning trigger at the binary input
- 2 Transferring the external hold over binary output to other measuring devices without connected cleaning functions
- 3 Transferring the cleaning trigger over a binary output to other self-cleaning measuring points

1. An external trigger actuates a cleaning operation at the master. A cleaning unit is connected via a relay or a binary output, for example.
2. The cleaning trigger is transferred to another device via a binary output. This does not have its own connected cleaning unit, but its sensors are installed in the medium affected by cleaning the master and are set to hold by the trigger.
3. The trigger is transferred via an additional binary output to another device, whose connected sensors have their own cleaning units. The signal can be used to simultaneously activate a self-cleaning with the master.

Interrupting the operation via an external signal

You can temporarily interrupt the automatic operation of the analyzer via an external signal at the "DIO" module. This can be useful if no sample is available in your process at certain times, e.g. during a cleaning phase.

The following information is processed at the binary inputs or output at the binary outputs:

- Binary inputs:
 - Signal for process access:** The analyzer can only perform activities that require sample (measurement, calibration, cleaning) when the signal is active. The time and the sequence of activities correspond to the settings in the setup. All activities that require sample are delayed as long as the signal is inactive.
- Binary outputs:
 - Signal **Measurement active:** Indicates that a measurement is currently running. The signal is not active in the event of a calibration or cleaning.
 - Signal **Sample required:** The signal is active for a configurable time before every activity that requires sample. This makes it possible to activate an external pump or a dilution module, for example.

1. Select **Menu/Setup/Inputs/Binary input x:y**.
2. Configure the binary inputs as follows:

Menu/Setup/Inputs/Binary input x:y ¹⁾		
Function	Options	Info
Binary input	Selection On	
Signal type	Selection Static signal	
Signal level	Selection <ul style="list-style-type: none"> ▪ High ▪ Low 	Specifies the active signal level: Low Input signals between 0 and 5 V DC High Input signals between 11 and 30 V DC

1) x:y = slot no. : input number

3. Link the binary inputs to the analyzer: select **Menu/Setup/Analyzer/Extended setup/Signal for process access**.
4. Select the measuring channel **SP1** or in the case of two-channel devices select measuring channel **SP1** or **SP2**.
5. Assign a binary output to the selected measuring channel: select **Binary input x:y**.

Controlling the measurement start time via an external signal

You can temporarily interrupt the automatic operation of the analyzer via an external signal at the "DIO" module. You can also use this signal to specifically start individual measurements. In this way, you can specify the time of the measurements using your external control system.

For this purpose, connect the **Signal for process access** to a binary input of the "DIO" module and set the starting time of the measurements to **Continuous**. A measurement starts immediately as soon as the signal at the binary input is active. The only exception is if a calibration or cleaning is due on the basis of the set time intervals: in this case, these activities are performed first of all and then the measurement follows immediately afterwards. Where necessary, connect the signal **Measurement active** to a binary output to identify when the measurement actually begins. If you do not want any more measurements after the end of the first measurement, you have to deactivate the **Signal for process access** while the measurement is still running.

The following information is processed at the binary inputs or output at the binary outputs:

■ Binary inputs:

Signal for process access: The analyzer can only perform activities that require sample (measurement, calibration, cleaning) when the signal is active. The time and the sequence of activities correspond to the settings in the setup. All activities that require sample are delayed as long as the signal is inactive.

■ Binary outputs:

- Signal **Measurement active:** Indicates that a measurement is currently running. The signal is not active in the event of a calibration or cleaning.
- Signal **Sample required:** The signal is active for a configurable time before every activity that requires sample. This makes it possible to activate an external pump or a dilution module, for example.

1. For the measurement under **Menu/Setup/Analyzer/Measurement** select the start condition **Continuous** (analyzer measures continuously, without interruption, between the measurements).
2. Select **Menu/Setup/Inputs/Binary input x:y**.
3. Configure the binary inputs as follows:

Menu/Setup/Inputs/Binary input x:y ¹⁾		
Function	Options	Info
Binary input	Selection On	
Signal type	Selection Static signal	
Signal level	Selection <ul style="list-style-type: none"> ■ High ■ Low 	Specifies the active signal level: Low Input signals between 0 and 5 V DC High Input signals between 11 and 30 V DC

1) x:y = slot no. : input number

4. Link the binary inputs to the analyzer: select **Menu/Setup/Analyzer/Extended setup/Signal for process access**.
5. Select the measuring channel **SP1** or in the case of two-channel devices select measuring channel **SP1** or **SP2**.
6. Assign a binary output to the selected measuring channel: select **Binary input x:y**.
7. Select **Menu/Setup/Outputs/Binary output x:y**.
8. Configure the binary outputs as follows:

Menu/Setup/Outputs/Binary output x:y ¹⁾		
Function	Options	Info
Binary output	Selection On	
Signal type	Selection Static signal	
Function	Selection Analyzer	
Assignments Function = Analyzer	Selection Measurement active SP1	Here you select which binary outputs output the system status for a measurement currently running. In the case of two-channel devices, Measurement active SP2 is also displayed

1) x:y = slot no. : input number

9. To confirm, select **OK**.
 - ↳ The binary inputs and binary outputs are configured.
10. Switch back to the automatic mode: press the **MODE** and select **Continue automatic mode** or **Start automatic mode**.
 - ↳ The display shows **Current mode- Automatic**.

Activating an external pump before every measurement

If you convey the sample to the analyzer using an external pump or an external sample preparation system, you can use the **Signal for sample request** to switch on the external devices for a limited time only when the analyzer requires sample. The signal becomes active before every measurement, calibration and cleaning. You can configure how long the signal should be active for. The start of the actual analyzer activity is delayed by this time.

1. Select **Menu/Setup/Analyzer/Extended setup/Signal for sample request**.
2. Under **Lead time** set how long an action that requires sample (measurement, calibration or cleaning) is delayed.
3. Under **Duration SP%C** set how long the signal should remain active. The duration can be longer than the lead time. The maximum possible value equals the lead time plus the duration of the measurement.
4. Configure the binary outputs as follows:

Menu/Setup/Outputs/Binary output x:y ¹⁾		
Function	Options	Info
Binary output	Selection On	
Signal type	Selection Static signal	
Function	Selection Analyzer	
Assignments Function = Analyzer	Selection Sample required SP1	Here you select which binary outputs output the system status for a measurement currently running. In the case of two-channel devices, Sample required SP2 is also displayed

1) x:y = slot no. : input number

5. ↳ The output signal level **High** indicates that sample is required.

10.5.2 Binary input configuration

Menu/Setup/Inputs/Binary input x:y ¹⁾		
Function	Options	Info
Binary input	Selection <ul style="list-style-type: none"> ■ Off ■ On Factory setting On	Switches the input on/off
Signal type	Selection <ul style="list-style-type: none"> ■ Static signal ■ PFM Factory setting Static signal	Select the signal type. Static signal Use this setting to read out the position of, for example, an on/off switch, an inductive proximity switch or a PLC binary output. Signal application: for measuring range switching, acceptance of an external hold, as a cleaning trigger or for controller activation PFM The PFM setting produces a pulse-frequency-modulated signal that is subsequently available on the device as a quasi-continuous process value. Example: Measuring signal of a flowmeter
Signal type = Static signal		
Signal level	Selection <ul style="list-style-type: none"> ■ Low ■ High Factory setting High	Determine which input signal levels should activate, for example, measuring range switching or a cleaning. Low Input signals between 0 and 5 V DC High Input signals between 11 and 30 V DC
Signal type = PFM		
Max. frequency	100.00 to 1000.00 Hz Factory setting 1000.00 Hz	Maximum frequency of the PFM input signal Is to equal the maximum possible upper limit of the measuring range. If the value selected is too small, higher frequencies will not be detected. If the value is too large, on the other hand, the resolution for small frequencies will be relatively inexact.
Meas. value format	Selection <ul style="list-style-type: none"> ■ # ■ #.# ■ #.## ■ #.### Factory setting #.#	Specify the number of decimal places.

Menu/Setup/Inputs/Binary input x:y ¹⁾		
Function	Options	Info
Input mode	Selection <ul style="list-style-type: none"> ▪ Frequency ▪ Parameter ▪ Flow rate Factory setting Frequency	Frequency Display in Hz in the measuring menu Parameter You subsequently determine the parameter name and unit. These are then displayed in the measuring menu. Flow rate For connecting a flowmeter
Parameter name Input mode = Parameter	Customized text, 16 characters	Define a name for the parameter, e.g. "pressure".
Unit of measure Input mode = Parameter	Customized text, 16 characters	Define the unit for your parameter, e.g. "hPa".
Lower range value Input mode = Parameter or Flow rate	-2000.00 to 0.00 Factory setting 0.00	The start of measuring range corresponds to a frequency of 0 Hz. Your previously defined unit is additionally displayed.
Upper range value Input mode = Parameter or Flow rate	0.00 to 10000.00 Factory setting 0.00	The end of measuring range corresponds to the maximum frequency defined above. Your previously defined unit is additionally displayed.
Damping	0 to 60 s Factory setting 0 s	The damping causes a floating average curve of the measured values over the time specified.

1) x:y = slot no. : input number

10.5.3 Configuration of binary outputs

Menu/Setup/Outputs/Binary output x:y ¹⁾		
Function	Options	Info
Binary output	Options <ul style="list-style-type: none"> ▪ Off ▪ On Factory setting On	Switches the output on/off
Signal type	Options <ul style="list-style-type: none"> ▪ Static signal ▪ PFM Factory setting Static signal	Select the signal type. Static signal Comparable to a relay: output of a diagnostic status, a limit switch or the status of an active measurement PFM You can output a measured value, e.g. the chlorine value or the manipulated variable of a controller. It functions as a "wear-free" switching contact that can be used to activate a dosing pump, for example.

Menu/Setup/Outputs/Binary output x:y ¹⁾		
Function	Options	Info
Signal type = Static signal		
Function	Options <ul style="list-style-type: none"> ▪ None ▪ Limit switches ▪ Diagnostics message ▪ Cleaning ▪ Analyzer Factory setting None	Source for the outputted switching state The following functions depend on the option selected. Function = None Switches off the function. There are no other settings.
Assignments Function = Cleaning	Multiple selection <ul style="list-style-type: none"> ▪ Cleaning 1 - Water ... ▪ Cleaning 4 - Cleaner 	Here you can decide which binary outputs should be used for activating the valves and pumps. Here you concretely assign a control signal to the binary output for the cleaner/water dosing of a cleaning program. You can define cleaning programs under: Menu/Setup/Additional functions/Cleaning in the measuring mode.
Data sources Function = Limit switches	Multiple selection Limit switch 1 ... 8	Select the limit switches that should be output via the binary output. Configuration of the limit switches: Menu/Setup/Additional functions/Limit switches in the measuring mode.
Operating mode Function = Diagnostics message	Options <ul style="list-style-type: none"> ▪ as assigned ▪ Namur M ▪ Namur S ▪ Namur C ▪ Namur F Factory setting as assigned	as assigned With this selection, the diagnosis messages are transmitted over the binary output that you individually allocated to it. Namur M ... F When you choose one of the Namur classes, all messages allocated to that respective class are output. You can change the Namur class assignment for every diagnostic message .
Assignments Function = Analyzer	Options <ul style="list-style-type: none"> ▪ None ▪ Sample required SP1 ▪ Measurement active SP1 Factory setting None	If this option is selected, the binary output outputs information as to whether a measurement is active on the selected measuring channel or an action is started that requires sample (measurement, calibration or cleaning). In the case of two-channel devices, Sample required SP2 and Measurement active SP2 is also displayed
Signal type = PFM		
Max. frequency	1.00 to 1000.00 Hz Factory setting 1000.00 Hz	Maximum frequency of the PFM output signal Is to equal the maximum possible upper limit of the measuring range.
Meas. value format	Options <ul style="list-style-type: none"> ▪ # ▪ #.# ▪ #.## ▪ #.### Factory setting #.##	Specify the number of decimal places.

Menu/Setup/Outputs/Binary output x:y ¹⁾		
Function	Options	Info
Source of data	Options <ul style="list-style-type: none"> ▪ None ▪ Sensor inputs ▪ Binary inputs ▪ Controller ▪ Fieldbus signals ▪ Mathematical functions Factory setting None	Source, whose value should be read out as a frequency over the binary output.
Measuring value Source of data ≠ Controller	Options Depends on: Source of data	Choose the measured value which should be output as the frequency via the binary output.
Actuator type Source of data = Controller	Options <ul style="list-style-type: none"> ▪ None ▪ Bipolar ▪ Unipolar+ ▪ Unipolar- Factory setting None	Specify which controller component the connected actuator, e.g. the dosing pump, should trigger. Bipolar "Split range" Unipolar+ Part of the manipulated variable that the controller uses to increase the process value Unipolar- For connected actuators that decrease the controlled variable
Hold behavior	Options <ul style="list-style-type: none"> ▪ Freeze ▪ Fixed value ▪ None Factory setting None	Freeze The device freezes the last value. Fixed value You define a fixed current value that is transmitted at the output. None A hold does not affect this output.
Hold value Hold behavior = Fixed value	0 to 100 % Factory setting 0 %	
Error behavior	Options <ul style="list-style-type: none"> ▪ Freeze ▪ Fixed value Factory setting Fixed value	Freeze The device freezes the last value. Fixed value You define a fixed current value that is transmitted at the output.
Error value Error behavior = Fixed value	0 to 100 % Factory setting 0 %	

1) x:y = slot no. : input number

10.6 Signal outputs

10.6.1 Current outputs

Liquiline System CA80 has two analog current outputs by default. You can configure additional current outputs with extension modules.

Setting the current output range

- ▶ **Menu/Setup/General settings:** select **0..20 mA** or **4..20 mA**.

Menu/Setup/Outputs/Current output x:y ¹⁾		
Function	Options	Info
Current output	Options <ul style="list-style-type: none"> ▪ Off ▪ On Factory setting Off	Use this function to activate or deactivate a variable being output at the current output
Source of data	Options <ul style="list-style-type: none"> ▪ None ▪ Connected inputs ▪ Controller Factory setting None	The sources of data on offer depend on your device version. The main value of the analyzer and all the sensors and controllers connected to inputs are available for selection.
Measured value	Options <ul style="list-style-type: none"> ▪ None ▪ Depends on the Source of data Factory setting None	The measured value you can select depends on the option selected under Source of data .
 The list of the dependent measured values can be found in the Measured value depending on the Source of data → 80. Apart from measured values from connected sensors, you can also select a controller as the data source. The best way to do so is by using the Additional functions menu. Here, you can select and configure the current output for outputting the controlled variable.		
Range lower value	Range of adjustment and factory settings depending on the Measured value	You can output the entire measuring range or just some of it at the current output. For this purpose, specify the upper and lower range values in accordance with your requirements.
Range upper value		
Hold behavior (for sensors)	Options <ul style="list-style-type: none"> ▪ Freeze ▪ Fixed value ▪ None Factory setting Depends on the channel:output	Freeze The device freezes the last current value. Fixed value You define a fixed current value that is output at the output. None A hold does not affect this current output.
Hold current (for sensors) Hold behavior = Fixed value	0.0 to 23.0 mA Factory setting 22.0 mA	Specify which current should be output at this current output in the hold state.

1) x:y = slot: output number

Measured value depending on the Source of data

Source of data	Measured value
Iron	Selection Main value
pH Glass	Selection <ul style="list-style-type: none"> ▪ Raw value mV ▪ pH ▪ Temperature
pH ISFET	
ORP	Selection <ul style="list-style-type: none"> ▪ Temperature ▪ ORP mV ▪ ORP %

Source of data	Measured value
Oxygen (amp.)	Selection <ul style="list-style-type: none"> ■ Temperature ■ Partial pressure ■ Concentration liquid ■ Saturation ■ Raw value nA (only Oxygen (amp.)) ■ Raw value μs (only Oxygen (opt.))
Oxygen (opt.)	
Cond i	Selection <ul style="list-style-type: none"> ■ Temperature ■ Conductivity ■ Resistance (only Cond c) ■ Concentration (only Cond i and Cond c 4-pol)
Cond c	
Disinfection	Selection <ul style="list-style-type: none"> ■ Temperature ■ Sensor current ■ Concentration
ISE	Selection <ul style="list-style-type: none"> ■ Temperature ■ pH ■ Ammonium ■ Nitrate ■ Potassium ■ Chloride
TU/TS	Selection <ul style="list-style-type: none"> ■ Temperature ■ Turbidity g/l (only TU/TS) ■ Turbidity FNU (only TU/TS) ■ Turbidity Formazine (only TU) ■ Turbidity solid (only TU)
TU	
Nitrate	Selection <ul style="list-style-type: none"> ■ Temperature ■ NO₃ ■ NO₃-N
Ultrasonic interface	Selection <ul style="list-style-type: none"> ■ Temperature ■ Interface ■ Turbidity
SAC	Selection <ul style="list-style-type: none"> ■ Temperature ■ SAC ■ Transm. ■ Absorption ■ COD ■ BOD
Controller 1 Current input 1 ... 3	Selection <ul style="list-style-type: none"> ■ Bipolar (only for current outputs) ■ Unipolar+ ■ Unipolar-
Controller 2 Temperature 1 ... 3	
Mathematical functions	All the mathematical functions can also be used as a data source and the calculated value can be used as the measured value.

Outputting the controller manipulated variable via the current output

Assign **Unipolar+** to the output to which an actuator that can increase the measured value is connected. Assign **Unipolar-** to the output to which an actuator that can decrease the measured value is connected.

To output the manipulated variable of a two-sided controller, positive manipulated variables and negative manipulated variables generally have to be output to different actuators, as most actuators are able to influence the process in one direction only (not in both). For this purpose, the instrument splits the bipolar manipulated variable y into two unipolar manipulated variables, y+ and y-.

Only the two unipolar manipulated variable parts are available for selection for outputting to modulated relays. If outputting the values via a current output, you also have the possibility of outputting the bipolar manipulated variable y to one current output only (split range).

10.6.2 Alarm relay and optional relays

The basic version of the device always has one alarm relay. Additional relays are also available depending on the version of the device.

The following functions can be output via a relay:

- Limit switch status
- Controller manipulated variable for controlling an actuator
- Diagnostic messages
- Status of a cleaning function in order to control a pump or a valve

 You can assign a relay to multiple inputs in order to clean several sensors with just one cleaning unit, for example.

Menu/Setup/Outputs/Alarm relay or relay at channel no.		
Function	Options	Info
Function	<p>Options</p> <ul style="list-style-type: none"> ▪ Off ▪ Limit switch ▪ Controller ▪ Diagnostics ▪ Cleaning (sensor) ▪ Analyzer <p>Factory setting</p> <ul style="list-style-type: none"> ▪ Alarm relays: Diagnostics ▪ Other relays: Off 	<p>The following functions depend on the option selected. These versions are illustrated individually in the following sections to provide a clearer understanding of the options.</p> <p>Function = Off Switches off the relay function and means no further settings are required.</p>

Outputting the status of a limit switch

Function = Limit switch		
Function	Options	Info
Source of data	<p>Options</p> <ul style="list-style-type: none"> ▪ None ▪ Limit switch 1 ... 8 <p>Factory setting None</p>	<p>Select the limit switch via which the status of the relay is to be output.</p> <p>The limit switches are configured in the menu: Setup/Additional functions/Limit switches in the measuring mode.</p>

Outputting the manipulated variable of a controller

To output a controller manipulated variable via a relay, the relay is modulated. The relay is energized (pulse, t_1) and is then de-energized (interval, t_0).

Function = Controller		
Function	Options	Info
Source of data	Options <ul style="list-style-type: none"> ■ None ■ Controller 1 ■ Controller 2 Factory setting None	Select the controller that should act as the data source.
Operating mode	Options <ul style="list-style-type: none"> ■ PWM ■ PFM Factory setting PWM	PWM=pulse width modulation PFM=pulse frequency modulation

1. **PWM** (pulse width modulation):

The duty cycle is varied within a period T ($T=t_1+t_0$). The cycle duration remains constant.

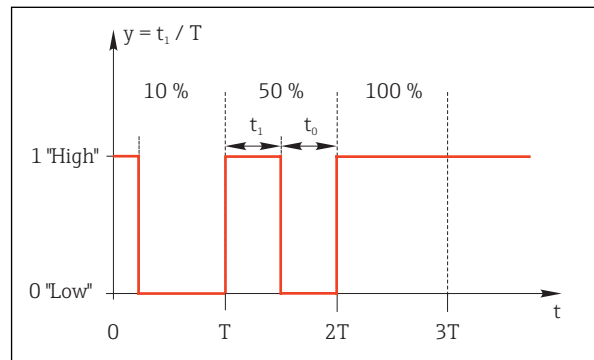

63 Typical application: solenoid valve

2. **PFM** (pulse frequency modulation):

Here, pulses of a constant length (t_1) are output and the interval between the pulses varies (t_0). At a maximum frequency, $t_1 = t_0$.

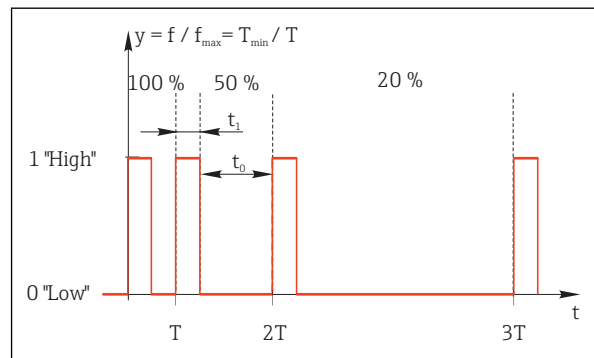

64 Typical application: dosing pump

Function = Controller		
Function	Options	Info
Actuator type	Options <ul style="list-style-type: none"> ▪ None ▪ Unipolar(-) ▪ Unipolar(+) Factory setting None	Here you specify what part of the controller should power the relay. Unipolar(+) is the part of the manipulated variable which the controller uses to increase the process value (e.g. for heating purposes). On the other hand, select Unipolar(-) if you want to connect an actuator to the relay that causes the controlled variable to drop (e.g. for cooling purposes).
Cycle duration Operating mode = PWM	Shortest turn-on time to 999.0 s Factory setting 10.0 s	Specify the cycle duration within which the duty cycle should be varied (only PWM).
 The settings for Cycle duration and Shortest turn-on time mutually affect one another. The following applies Cycle duration ≥ Shortest turn-on time .		
Shortest turn-on time Operating mode = PWM	0.3 s to Cycle duration Factory setting 0.3 s	Pulses that are shorter than this limit value are not output in order to conserve the actuator.
Maximum frequency Operating mode = PFM	1 to 180 min ⁻¹ Factory setting 60 min ⁻¹	Maximum number of pulses per minute The controller calculates the pulse duration based on this setting.

Outputting diagnostic messages via the relay

If a relay is defined as a diagnostic relay (**Function = Diagnostics**), it works in the "**fail-safe mode**".

This means that the relay is always energized ("normally closed", n.c.) in the basic state if an error is not present. In this way it can also indicate a drop in voltage, for example. The alarm relay always works in the failsafe mode.

You can output two categories of diagnostic messages via the relay:

- Diagnostic messages from one of the 4 Namur classes
- Diagnostic messages which you have individually assigned to the relay output

A message is individually assigned to the relay output at 2 specific points in the menu:

- **Menu/Setup/General settings/Extended setup/Diagnostics settings/Diag. behavior** (device-specific messages)
- **Menu/Setup/Inputs/<Sensor>/Extended setup/Diagnostics settings/Diag. behavior** (sensor-specific messages)

 Before being able to assign the relay output to a special message in **Diag. behavior** you must first configure **Outputs/Relay x:y** or **/Alarm relay/Function = Diagnostics** .

Function = Diagnostics		
Function	Options	Info
Operating mode	Options <ul style="list-style-type: none"> ▪ as assigned ▪ Namur M ▪ Namur S ▪ Namur C ▪ Namur F Factory setting as assigned	as assigned If this option is selected, the diagnostic messages which you have individually assigned to the relay are output via the relay. Namur M ... Namur F If you decided to use one of the Namur classes, all the messages that are assigned to the individual class are output via the relay. You can also change the Namur class assignment for every diagnostic message. (Menu/Setup/General settings/Extended setup/Diagnostics settings/Diag. behavior or Menu/Setup/Inputs/<Sensor>/Extended setup/Diagnostics settings/Diag. behavior)
Attributed diagnostic messages Operating mode = as assigned	Read only	All the messages assigned to the relay output appear on the display. You do not have the option of editing the information here.

Outputting the status of a cleaning function

Function = Cleaning (for sensors)		
Function	Options	Info
Assignments	Options <ul style="list-style-type: none"> ▪ None ▪ Depends on the type of cleaning Factory setting None	Here you can specify how a cleaning function should be displayed for the relay. Depending on the cleaning program selected (Menu/Setup/Additional functions/Cleaning) you can choose from the following: <ul style="list-style-type: none"> ▪ Cleaning type = Standard clean Cleaning 1 - Water, Cleaning 2 - Water, Cleaning 3 - Water, Cleaning 4 - Water ▪ Cleaning type = Chemoclean Cleaning 1 - Water, Cleaning 1 - Cleaner, Cleaning 2 - Water, Cleaning 2 - Cleaner, Cleaning 3 - Water, Cleaning 3 - Cleaner, Cleaning 4 - Water, Cleaning 4 - Cleaner ▪ Cleaning type = Chemoclean Plus 4x Cleaning 1 - %0V, 4x Cleaning 2 - %0V¹⁾

1) %0V is variable text which you can assign in Menu/Setup/Additional functions/Cleaning/Chemoclean Plus/Output label 1 ... 4 .

Outputting the "Measurement active" system status and the information "Sample required"

Function = Analyzer		
Function	Options	Info
Signal type = Static signal		
Assignments Function = Analyzer	Selection <ul style="list-style-type: none"> ▪ None ▪ Sample required SP1 ▪ Measurement active SP1 Factory setting None	If this option is selected, information is output as to whether a measurement is active on the selected measuring channel or an action is started that requires sample (measurement, calibration or cleaning). In the case of two-channel devices, Sample required SP2 and Measurement active SP2 are also displayed

10.6.3 PROFIBUS DP

Device variables (device → PROFIBUS)

Specify which process values should be mapped to the PROFIBUS function blocks and are thereby available for transmission via PROFIBUS communication.

You can define a maximum of 16 device variables (AI Blocks).

1. Define the data source.
 - ↳ You can choose from sensor inputs, current inputs and mathematical functions.
2. Choose the measured value which should be transmitted.
3. Define how the device should behave in the event of a "Hold" (for sensors).
(Configuration options of **Source of data**, **Measured value** and **Hold behavior**)
→  80

Please note that if you select **Hold behavior** = **Freeze**, the system not only flags the status but also actually "freezes" the measured value.

In addition, you can define 8 binary variables (DI Blocks):

1. Define the data source.
2. Select the limit switch or relay whose status should be transmitted.

PROFIBUS variables (PROFIBUS → device)

A maximum of 4 analog (AO) and 8 digital (DO) PROFIBUS variables are available as measured values in the controller, limit switch or current output menus.

Example: Using an AO or DO value as the set point for the controller

Menu/Setup/Additional functions/Controller 1

1. In the menu mentioned, define PROFIBUS as the data source.
2. Select the desired analog output (AO) or digital output (DO) as the measured value.



More information is provided in:

Guidelines for Communication via PROFIBUS, SD01188C

10.6.4 Modbus RS485 and Modbus TCP

Specify which process values should be output via Modbus RS485 communication or via Modbus TCP.

In the case of Modbus RS485, you can switch between the RTU and the ASCII protocol.

You can define a maximum of 16 device variables.

1. Define the data source.
 - ↳ You can choose from the analyzer as well as sensor inputs and controllers.
2. Choose the measured value which should be output.
3. Define how the device should behave in the event of a "Hold" (for sensors).
(Configuration options of **Source of data**, **Measured value** and **Hold behavior**)
→  80

Please note that if you select **Hold behavior** = **Freeze**, the system not only flags the status but also actually "freezes" the measured value.



More information is provided in:

Guidelines for Communication via Modbus, SD01189C

10.6.5 EtherNet/IP

Specify which process values should be output via EtherNet/IP communication.

You can define a maximum of 16 analog device variables (AI).

1. Define the data source.
 - ↳ You can choose from the analyzer as well as sensor inputs and controllers.
2. Choose the measured value which should be output.
3. Define how the device should behave in the event of a "Hold" (for sensors).
 (Configuration options of **Source of data**, **Measured value** and **Hold behavior**)
 →  80
4. In the case of controllers, also specify the type of manipulated variable.

Please note that if you select **Hold behavior = Freeze**, the system not only flags the status but also actually "freezes" the measured value.

In addition you can define 8 digital device variables (DI):

- ▶ Define the data source.
 - ↳ You can choose from relays, binary inputs and limit switches.



More information is provided in:

Guidelines for Communication via EtherNet/IP, SD01293C

10.7 Additional functions

10.7.1 Limit contactors

There are different ways to configure a limit switch:

- Assigning a switch-on and switch-off point
- Assigning a switch-on and switch-off delay for a relay
- Setting an alarm threshold and also outputting an error message
- Starting a cleaning function (for sensors)

Menu/Setup/Additional functions/Limit switches/Limit switch 1 ... 8		
Function	Options	Info
Source of data	Selection <ul style="list-style-type: none"> ▪ None ▪ Sensor inputs ▪ Binary inputs ▪ Controller ▪ Fieldbus signals ▪ Mathematical functions ▪ MRS set 1 ... 2 Factory setting None	Specify the input or output which should be the source of data for the limit switch. The sources of data on offer depend on your device version. You can choose from connected sensors, binary inputs, fieldbus signals, mathematical functions, controllers and sets for measuring range switching.
Measuring value	Selection Depends on: Source of data	Select the measured value, see the following table.

Measured value depending on the Source of data

Source of data	Measured value
Iron	Selection Main value
pH Glass	Selection <ul style="list-style-type: none"> ▪ Raw value mV ▪ pH ▪ Temperature
pH ISFET	
ORP	Selection <ul style="list-style-type: none"> ▪ Temperature ▪ ORP mV ▪ ORP %
Oxygen (amp.)	Selection <ul style="list-style-type: none"> ▪ Temperature ▪ Partial pressure ▪ Concentration liquid ▪ Saturation ▪ Raw value nA (only Oxygen (amp.)) ▪ Raw value µs (only Oxygen (opt.))
Oxygen (opt.)	
Cond i	Selection <ul style="list-style-type: none"> ▪ Temperature ▪ Conductivity ▪ Resistance (only Cond c) ▪ Concentration (only Cond i and Cond c 4-pol)
Cond c	
Disinfection	Selection <ul style="list-style-type: none"> ▪ Temperature ▪ Sensor current ▪ Concentration
ISE	Selection <ul style="list-style-type: none"> ▪ Temperature ▪ pH ▪ Ammonium ▪ Nitrate ▪ Potassium ▪ Chloride
TU/TS	Selection <ul style="list-style-type: none"> ▪ Temperature ▪ Turbidity g/l (only TU/TS) ▪ Turbidity FNU (only TU/TS) ▪ Turbidity Formazine (only TU) ▪ Turbidity solid (only TU)
TU	
Nitrate	Selection <ul style="list-style-type: none"> ▪ Temperature ▪ NO₃ ▪ NO₃-N
Ultrasonic interface	Selection <ul style="list-style-type: none"> ▪ Temperature ▪ Interface ▪ Turbidity

Source of data	Measured value
SAC	Selection <ul style="list-style-type: none"> ■ Temperature ■ SAC ■ Transm. ■ Absorption ■ COD ■ BOD
Controller 1 Current input 1 ... 3	Selection <ul style="list-style-type: none"> ■ Bipolar <i>(only for current outputs)</i> ■ Unipolar+ ■ Unipolar-
Controller 2 Temperature 1 ... 3	
Mathematical functions	All the mathematical functions can also be used as a data source and the calculated value can be used as the measured value.



You can monitor the manipulated variable by assigning the controller manipulated variable to a limit switch (e.g. configure a dosing time alarm).

Menu/Setup/Additional functions/Limit switches/Limit switch 1 ... 8		
Function	Options	Info
Cleaning program	Selection <ul style="list-style-type: none"> ■ None ■ Cleaning 1 ... 4 Factory setting None	Use this function to choose the cleaning instance which should be started when the limit switch is active.
Function	Selection <ul style="list-style-type: none"> ■ Off ■ On Factory setting Off	Activating/deactivating the limit switch
Operating mode	Selection <ul style="list-style-type: none"> ■ Above limit check ■ Below limit check ■ In range check ■ Out of range check ■ Change rate Factory setting Above limit check	Type of limit value monitoring: <ul style="list-style-type: none"> ■ Limit value overshoot or undershoot → 65 ■ Measured value within or outside a range → 66 ■ Rate of change → 68

Menu/Setup/Additional functions/Limit switches/Limit switch 1 ... 8		
Function	Options	Info
Limit value	Settings depend on the measured value	Operating mode = Above limit check or Below limit check
<div style="display: flex; justify-content: space-around;"> <div style="text-align: center;"> <p>(A)</p> </div> <div style="text-align: center;"> <p>(B)</p> </div> </div> <p style="text-align: right; font-size: small;">A0028523</p> <p>☑ 65 Exceeding (A) and undershooting (B) a limit value (without hysteresis and switch-on delay)</p> <p>1 Limit value 2 Alarm range $t_{1,3,5}$ No action $t_{2,4}$ An event is generated</p> <ul style="list-style-type: none"> ■ If the measured values (MV) are increasing, the relay contact is closed when the on-value is exceeded (Limit value + Hysteresis) and the start delay (Start delay) has elapsed. ■ If the measured values are decreasing, the relay contact is reset when the off-value is undershot (Limit value - Hysteresis) and following the drop-out delay (Switch off delay). 		
Range lower value	Settings depend on the measured value	Operating mode = Out of range check or In range check
Range upper value		
<div style="display: flex; justify-content: space-around;"> <div style="text-align: center;"> <p>(A)</p> </div> <div style="text-align: center;"> <p>(B)</p> </div> </div> <p style="text-align: right; font-size: small;">A0028524</p> <p>☑ 66 Range monitoring outside (A) and within (B) a range (without hysteresis and switch-on delay)</p> <p>1 End of range 2 Start of range 3 Alarm range t_{1-4} An event is generated</p> <ul style="list-style-type: none"> ■ If the measured values (MV) are increasing, the relay contact is closed when the on-value is exceeded (Range lower value + Hysteresis) and the start delay (Start delay) has elapsed. ■ If the measured values are decreasing, the relay contact is reset when the off-value is undershot (Range upper value - Hysteresis) and following the drop-out delay (Switch off delay). 		

Menu/Setup/Additional functions/Limit switches/Limit switch 1 ... 8		
Function	Options	Info
<p>Hysteresis</p> <p>A0028525</p> <p>☐ 67 Hysteresis taking the example of limit value overshoot</p> <p>1 Limit value 2 Alarm range 3 Hysteresis range $t_{1,2}$ An event is generated</p>	<p>Settings depend on the measured value</p>	<p>Operating mode ≠ Change rate</p> <p>The hysteresis is needed to ensure a stable switching behavior. The device software adds or subtracts the value set here to/from the limit value (Limit value, Range lower value or Range upper value). This results in double the Hysteresis value for the hysteresis range around the limit value. An event is then only generated if the measured value (MV) completely passes through the hysteresis range.</p>
<p>Start delay</p> <p>Operating mode ≠ Change rate</p>	<p>0 to 9999 s</p> <p>Factory setting 0 s</p>	<p>Synonyms: pick-up and drop-out delay</p>
<p>Switch off delay</p> <p>Operating mode ≠ Change rate</p>		
<p>Delta value</p>	<p>Settings depend on the measured value</p>	<p>Operating mode = Change rate</p> <p>The slope of the measured value (MV) is monitored in this mode. An event is generated if, in the given timeframe (Delta time), the measured value increases or decreases by more than the specified value (Delta value). No further event is generated if the value continues to experience such a steep increase or decrease. If the slope is back below the limit value, the alarm status is reset after a preset time (Auto Confirm).</p> <p>Events are triggered by the following conditions in the example given: $t_2 - t_1 < \text{Delta time}$ and $\Delta MV_1 > \text{Delta value}$ $t_4 - t_3 > \text{Auto Confirm}$ and $\Delta MV_2 < \text{Delta value}$ $t_6 - t_5 < \text{Delta time}$ and $\Delta MV_3 > \text{Delta value}$</p>
<p>Delta time</p>	<p>00:01 to 23:59</p> <p>Factory setting 01:00</p>	
<p>Auto Confirm</p>	<p>00:01 to 23:59</p> <p>Factory setting 00:01</p>	
<p>A0028526</p> <p>☐ 68 Rate of change</p>		

10.7.2 Controller

Controller structure in Laplace representation

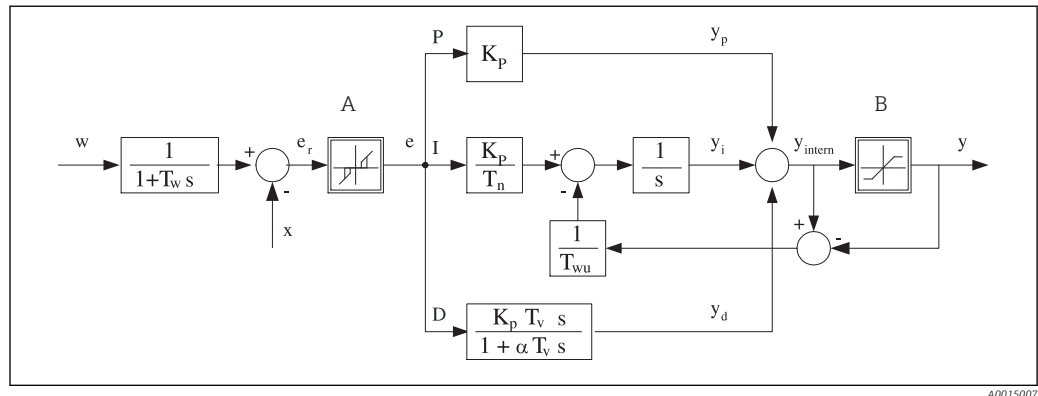

69 Block diagram of the controller structure

A	Neutral zone	I	Integral value
B	Output limiting	D	Derivative value
K_p	Gain (P-value)	αT_v	Damping time constant with $\alpha = 0$ to 1
T_n	Integral action time (I-value)	e	Control deviation
T_v	Derivative action time (D-value)	w	Set point
T_w	Time constant for set point damping	x	Controlled variable
T_{wu}	Time constant for anti-windup feedback	y	Manipulated variable
P	Proportional value		

The controller structure of the device comprises set point damping at the input to prevent erratic changes in the manipulated variable if the set point changes. The difference between the set point w and the controlled variable (measured value) X results in the control deviation which is filtered by a neutral zone.

The neutral zone is used to suppress control deviations (e) that are too small. The control deviation thus filtered is now fed to the actual PID controller which divides into three parts based on the P (proportional), I (integral) and D (derivative) values (top-down). The integral section (middle) also comprises an anti-windup mechanism for limiting the integrator. A low-pass filter is added to the D-section to damp hard D-terms in the manipulated variable. The sum of the 3 sections results in the internal controller manipulated variable which is limited according to the settings (for PID-2s to -100% to +100%).

The graphic does not illustrate a downstream filter for limiting the rate of change of the manipulated variable (can be configured in the menu in **Max y change rate**).

i In the menu do not configure the gain K_p . Instead configure the reciprocal value, the proportional band X_p ($K_p=1/X_p$).



Configuration

Make the following decisions when configuring a controller:

- (1) What type of process can your process be assigned to? → **Process type**
- (2) Should it be possible to influence the measured variable (controlled variable) in one direction or in both directions? One-sided or two-sided controller, → **Controller type**
- (3) What should be the controlled variable (sensor, measured value)? → **Controlled variable**
- (4) Do you have a disturbance variable that should be active at the controller output? → **Disturbance variable**

- (5) Define the parameters for the controller:
 - Set point, → **Setpoint**
 - Neutral zone, → **Xn**
 - Proportional band, → **Xp**
 - Integral action time (I-value), → **Tn**
 - Derivative action time (D-value), → **Tv**
- (6) What should the controller do in the event of a hold (measured error, sensor replacement, cleaning etc.)?
 - Pause or continue with dosing? → **Hold behavior/Manipulated Variable**
 - At the end of a hold, continue or restart the control loop (affects I-value)? → **Hold behavior/State**
- (7) How should the actuator be triggered?
 - **Unipolar+**: Assign this setting to the output for an actuator which can increase the measured value.
 - **Unipolar-**: Assign this setting to the output for an actuator which can decrease the measured value.
 - **Bipolar**: Select this setting if you want to output the manipulated variable via one current output only (split range).
- (8) Configure the outputs and switch on the controller.

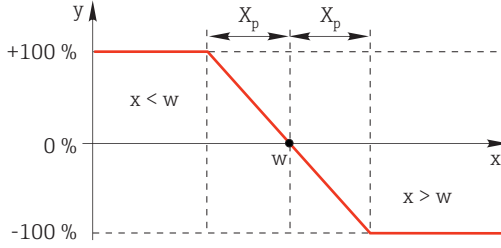
Menu/Setup/Additional functions/Controller 1 ... 2		
Function	Options	Info
Control	Selection <ul style="list-style-type: none"> ▪ Off ▪ Automatic ▪ Manual mode Factory setting Off	First configure the controller and leave the switch at the factory setting (Off). Once you have made all the settings, you can assign the controller to an output and switch it on.
▶ Manual mode		
y	-100 to 100 % Factory setting 0 %	Specify the manipulated variable that should be output in manual mode.
y Actual output	Read only	Manipulated variable actually output.
Setpoint		Current set point
x		Current measured value
Disturbance variable		Current measured value of disturbance variable
Norm. disturb. value		
Name	Free text	Give the controller a name so you can identify it later on.
Controller Enable	Selection <ul style="list-style-type: none"> ▪ None ▪ Binary inputs ▪ Limit switches ▪ Fieldbus variables Factory setting None	In connection with the DIO module, you can select a binary input signal, e.g. from an inductive proximity switch, as a source for enabling the controller.
Setup Level	Selection <ul style="list-style-type: none"> ▪ Standard ▪ Advanced Factory setting Standard	Changes the number of parameters that can be configured. → Parameters → 97 Standard : If you choose this, the other controller parameters are active nevertheless. The system uses the factory settings which usually suffice in most cases.

Menu/Setup/Additional functions/Controller 1 ... 2		
Function	Options	Info
Process type	Selection <ul style="list-style-type: none"> ■ Inline ■ Batch Factory setting Inline	Decide what type of process best describes your particular process.
<p>Batch process The medium is in a closed system. The task of the control system is to dose in such a way that the measured value (controlled variable) changes from its start value to its target value. No more dosing is needed once the set point has been reached and the system is stable. If the target value is overshoot, a two-sided control system can compensate for this. In the case of 2-sided batch control systems, a neutral zone is used/configured to suppress oscillations around the set point.</p> <p>In-line process In an in-line process, the control system works with the medium flowing by in the process. Here, the controller has the task of using the manipulated variable to set a mixture ratio between the medium and dosing agent such that the resulting measured variable corresponds to the set point. The properties and volume of the medium flow can change at any time and the controller has to react to these changes on a continuous basis. If the flow rate and medium remain constant, the manipulated variable can also assume a fixed value once the process has settled. Since the control process is never "finished" here, this type of control is also referred to as continuous control.</p> <p> A mixture of both process types can often be found in practice: the semi-batch process. Depending on the ratio between the flow and the container volume, this arrangement behaves either like a batch process or an in-line process.</p>		
Controller type	Selection <ul style="list-style-type: none"> ■ PID 1-sided ■ PID 2-sided Factory setting PID 2-sided	Depending on the actuator connected, you influence the process in just one direction (e.g. heating) or in both directions (e.g. heating and cooling).
<p>A 2-sided controller can output a manipulated variable in the range from -100% to +100%, i.e. the manipulated variable is bipolar. The manipulated variable is positive if the controller should increase the process value. In the case of a pure P-controller, this means that the value of the controlled variable x is smaller than the set point w. On the other hand, the manipulated variable is negative if the process value should be decreased. The value for x is greater than the set point w.</p>  <p> 70 Relationship $y = (w-x)/X_p$</p>		

Menu/Setup/Additional functions/Controller 1 ... 2		
Function	Options	Info
Effective direction Controller type = PID 1-sided	Selection <ul style="list-style-type: none"> ▪ Direct ▪ Reverse Factory setting Reverse	In what direction should the controller influence the measured value? <ul style="list-style-type: none"> ▪ The measured value should increase as a result of dosing (e.g. heating) → Reverse ▪ The measured value should decrease as a result of dosing (e.g. cooling) → Direct
<p>A 1-sided controller has a unipolar manipulated variable, i.e. it can only influence the process in one direction.</p> <p>Reverse: If the controller should increase the process value, set this as the direction of action. The controller becomes active when the process value is too small (range A).</p> <p>Direct: With this direction of action, the controller acts as a "downwards controller". It becomes active when the process value (e.g. the temperature) is too high (range B).</p>		
<p> 71 Red: overlap between the curves of the two 1-sided controllers.</p>		
▶ Controlled variable		
Source of data	Selection <ul style="list-style-type: none"> ▪ None ▪ Sensor inputs ▪ Current inputs ▪ Fieldbus signals ▪ Binary inputs ▪ Mathematical functions Factory setting None	Specify the input or output which should be the source of data for the controlled variable.
Measured value	Selection depend on Source of data Factory setting None	Specify the measured value that should be your controlled variable. You can use different measured values depending on the data source.
▶ Setpoint		Target value of the controlled variable This menu is not displayed if you selected a fieldbus as the source (Source of data = fieldbus).
Setpoint	Range of adjustment and factory setting depending on the Source of data	Specify the target value for the controlled variable.
Tw Setup Level = Advanced	0.0 to 999.9 s Factory setting 2.0 s	Time constant for the set point damping filter
▶ Disturbance variable		optional, activation code necessary

Menu/Setup/Additional functions/Controller 1 ... 2

Function	Options	Info
----------	---------	------

With "flowing medium" (inline) controls, it can happen that the flow rate is non-constant. In some circumstances, strong fluctuations are possible. In the case of a settled control system in which the flow rate is suddenly halved, it is desirable that the dosed quantity from the controller is also directly halved. In order to achieve this type of "flow-rate-proportional" dosing, this task is not left to the I-component of the controller, but rather one enters the (to be measured) flow rate as disturbance variable z multiplicative at the controller output.

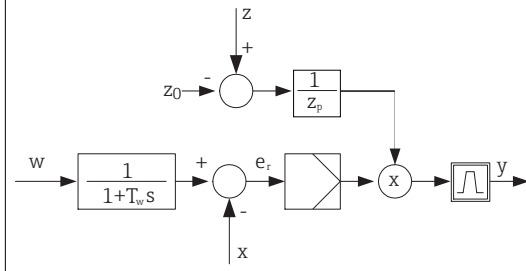

Strictly speaking, feedforward control involves an open-loop control system, since its effect is not measured directly. That means that the feed flow is directed exclusively forward. Hence the designation "feedforward control."

For the additive feedforward control that is alternatively available in the device, the (standardized) disturbance variable is added to the controller manipulated variable. This enables you to set up a type of variable base load dosing.

The standardization of the disturbance variable is required both for multiplicative and for additive feedforward control and is done using parameters Z_0 (zero point) and Z_p (proportional band): $z_n = (z - z_0)/Z_p$

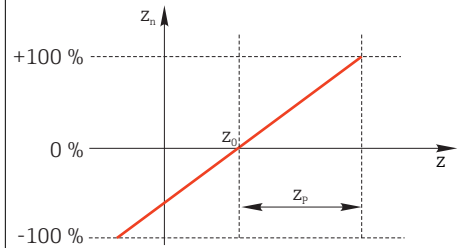

Example

Flowmeter with measuring range 0 to 200 m³/h
 The controller would currently dose 100% without feedforward control.
 The feedforward control should be configured such that at $z = 200\text{m}^3/\text{h}$, the controller still doses at 100% ($z_n = 1$).
 If the flow rate drops, the dosing rate should be reduced, and at a flow rate of less than 4 m³/h, dosing should stop entirely ($z_n = 0$).
 → Select the zero point $z_0 = 4\text{ m}^3/\text{h}$ and the proportional band $Z_p = 196\text{ m}^3/\text{h}$.

Function	Selection <ul style="list-style-type: none"> ▪ Off ▪ Multiply ▪ Add Factory setting Off	Selecting multiplicative or additive feedforward control
Source of data	Selection <ul style="list-style-type: none"> ▪ None ▪ Sensor inputs ▪ Current inputs ▪ Fieldbus signals ▪ Binary inputs ▪ Mathematical functions Factory setting None	Specify the input which should be the source of data for the disturbance variable.

Menu/Setup/Additional functions/Controller 1 ... 2		
Function	Options	Info
Measured value	Selection depend on Source of data Factory setting None	Specify the measured value that should be your disturbance variable. You can use different measured values depending on the data source.
Zp	Range of adjustment depending on the selection of the measured value	Proportional band -->
Z0		Zero point
► Parameters		The Liquiline PID controller has been implemented in the serial structural form, i.e. it has the following parameters: <ul style="list-style-type: none"> ▪ Integral action time T_n ▪ Derivative action time T_v ▪ Proportional band X_p Setup Level = Advanced: With this setup level, you can also configure the following: <ul style="list-style-type: none"> ▪ Time constant T_{wu} ▪ Time constant α ▪ Width of the neutral zone X_n ▪ Width of the hysteresis range of the neutral zone X_{hyst} ▪ Cycle time of the controller
T_n	0.0 to 9999.0 s Factory setting 0.0 s	The integral action time specifies the effect of the I-value If $T_n > 0$ the following applies: $Clock < T_{wu} < 0.5(T_n + T_v)$
The integral action time is the time needed in a step-function response to achieve a change in the manipulated variable - as a result of the I effect - which has the same magnitude as the P-value.		
$e = \text{control deviation, } e=w-x \text{ (set point controlled variable)}$		

Menu/Setup/Additional functions/Controller 1 ... 2		
Function	Options	Info
Twu	0.1 to 999.9 s Factory setting 20.0 s	Time constant for anti-windup feedback The lower the value the greater the integrator inhibition. Exercise extreme caution when making changes. Clock < Twu < 0.5(Tn + Tv)
Tv	0.1 to 999.9 s Factory setting 0.0 s	The derivative action time specifies the effect of the D-value The derivative action time is the time by which the ramp response of a PD controller reaches a specific value of the manipulated variable at an earlier stage than it would solely as a result of its P-value.
alpha	0.0 to 1.0 Factory setting 0.3	Affects the additional damping filter of the D-controller. The time constant is calculated from αT_v .
Process balance Controller type = PID 2-sided	Selection <ul style="list-style-type: none"> ▪ Symmetric ▪ Asymmetric Factory setting Symmetric	Symmetric There is only one control gain and this applies for both sides of the process. Asymmetric You can set the control gain individually for both sides of the process.
Xp Process balance = Symmetric	Range of adjustment and factory setting depending on the Source of data	Proportional band, reciprocal value of the proportional gain K_p As soon as controlled variable x deviates more than x_p from the set point w, manipulated variable y reaches 100%.
Xp Low Process balance = Asymmetric	Range of adjustment and factory setting depending on the Source of data	x_p for $y < 0$ (manipulated variable < 0)
Xp High Process balance = Asymmetric		x_p for $y > 0$ (manipulated variable > 0)
Xn	Range of adjustment and factory setting depending on the Source of data	Tolerance range about the set point that prevents minor oscillations about the set point if using two-sided control loops.
XN Low Process balance = Asymmetric	Range of adjustment and factory setting depending on the Source of data	x_n for $x < w$ (controlled variable < set point)
XN High Process balance = Asymmetric		x_n for $x > w$ (controlled variable > set point)

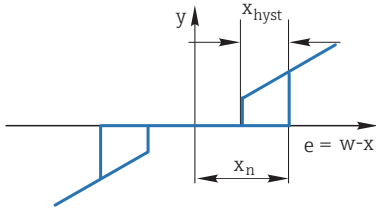
Menu/Setup/Additional functions/Controller 1 ... 2		
Function	Options	Info
XHyst	0.0 to 99.9 % Factory setting 0.0 %	Width of the hysteresis range of the neutral zone, relative component of x_n
 <p>The graphic illustrates the manipulated variable (with a pure P-controller) over the control deviation e (set point minus controlled variable). Very low control deviations are set to zero. Control deviations $> x_n$ are processed "in the normal way". Via x_{hyst} it is possible to configure a hysteresis to suppress oscillations at the edges.</p>		
Clock	0.333 to 100.000 s Factory setting 1.000 s	Expert setting! Only change the cycle time of the controller if you know exactly what you are doing! Clock < Twu < 0.5(Tn + Tv)
Max y change rate	0.00 to 1.00 Factory setting 0.40	Limits the change of the output variable A value of 0.5 permits a maximum manipulated variable change of 50% within one second.
► Hold behavior		Hold=measured value is no longer reliable
Manipulated Variable	Selection <ul style="list-style-type: none"> ■ Freeze ■ Fixed value Factory setting Freeze	How should the controller react to a measured value that is no longer reliable? Freeze The manipulated variable is frozen at the current value Fixed value Manipulated variable is set to 0 (no dosing)
State	Selection <ul style="list-style-type: none"> ■ Freeze ■ Reset Factory setting Freeze	Internal controller status Freeze No change Reset After a hold, the control system starts from scratch, and settling time takes place again.
► Outputs		Goes to the menu Outputs
► Controller assignment view		Shows an overview of the inputs and outputs used

10.7.3 Cleaning programs for sensors

⚠ CAUTION

Cleaning not switched off during calibration or maintenance activities

Risk of injury due to medium or cleaning agent

- If a cleaning system is connected, switch it off before removing a sensor from the medium.
- If you wish to check the cleaning function and have therefore not switched off the cleaning system, please wear protective clothing, goggles and gloves or take other appropriate measures.

Types of cleaning

The user can choose from the following cleaning types:

- Standard clean
- Chemoclean
- Chemoclean Plus

i State of cleaning: Indicates whether the cleaning program is active or not. This is for information purposes only.

Selecting the cleaning type

1. **Menu/Setup/Additional functions/Cleaning:** Select a cleaning program.
 - ↳ You can configure 4 different types of cleaning which you can assign individually to the inputs.
2. **Cleaning type:** For each cleaning program decide which type of cleaning should be performed.

Standard cleaning

Standard cleaning involves cleaning a sensor with compressed air, for instance, as performed with the ion-selective sensor CAS40D (connection of the cleaning unit for CAS40D →  33)

Menu/Setup/Additional functions/Cleaning/Cleaning 1 ... 4/Standard clean		
Function	Options	Info
Cleaning time	5 to 600 s Factory setting 10 s	Cleaning duration The cleaning duration and interval depend on the process and sensor. Determine the variables empirically or based on experience.

▶ Defining the cleaning cycle →  102

Chemoclean

An example is the use of the CYR10 injector unit to clean pH glass sensors. (CYR10 connection →  33)

Menu/Setup/Additional functions/Cleaning/Cleaning 1 ... 4/Chemoclean		
Function	Options	Info
Cleaning time	0 to 900 s Factory setting 5 s	Cleaning duration
Prerinse time	0 to 900 s	The cleaning duration, pre-rinse and post-rinse times and the interval depend on the process and sensor. Determine the variables empirically or based on experience.
Postrinse time	Factory setting 0 s	

Chemoclean Plus

An example is the use of the CYR10 injector unit to clean pH glass sensors. (CYR10 connection →  33)

Menu/Setup/Additional functions/Cleaning/Cleaning 1 ... 4/Chemoclean Plus/ChemoCleanPlus setup		
Function	Options	Info
Cleaning steps setup	Table to create a time program	You define a maximum of 30 program steps which should be performed one after the other. For each step enter the duration [s] and the state (0 = "off", 1 = "on") of each relay or output. You can specify the number and name of the outputs further down in the menu. See below for an example of programming.
Failsafe step setup	Table view	In the table specify the states that the relays or outputs should assume in the event of an error.
Limit contacts	0 to 2	Select the number of digital input signals (e.g. from limit position switches of the retractable assembly).
Limit contact 1 ... 2	Selection <ul style="list-style-type: none"> ■ Binary inputs ■ Fieldbus signals 	Define the signal source for each limit position switch.
Outputs	0 to 4	Select the number of outputs that actuators, such as valves or pumps, should activate.
Output label 1 ... 4	Free text	You can assign a meaningful name to each output, e.g. "assembly", "cleaner 1", "cleaner 2" etc.

Programming example: regular cleaning with water and 2 cleaning agents

Limit switch	Duration [s]	Assembly CPA87x	Water	Cleaner 1	Cleaner 2
ES1 1	5	1	1	0	0
ES2 1	5	1	1	0	0
0	30	1	1	0	0
0	5	1	1	1	0
0	60	1	0	0	0
0	30	1	1	0	0
0	5	1	1	0	1
0	60	1	0	0	0
0	30	1	1	0	0
ES1 0	5	0	1	0	0
ES2 0	5	0	1	0	0
0	5	0	0	0	0

The pneumatic retractable assembly, e.g. CPA87x, is activated by compressed air via a two-way valve. As a result, the assembly assumes either the "Measure" position (sensor in medium) or the "Service" position (sensor in rinse chamber). Media such as water or cleaning agents are supplied via valves or pumps. Here there are two states: 0 (= "off" or "closed") and 1 (= "on" or "open").



The hardware required for "Chemoclean Plus", such as control valves, pumps, compressed air supply, media supply etc., must be provided by the customer.

Defining the cleaning cycle

Menu/Setup/Additional functions/Cleaning/Cleaning 1 ... 4		
Function	Options	Info
Cleaning cycle	Selection <ul style="list-style-type: none"> ▪ Off ▪ Interval ▪ Weekly program Factory setting Weekly program	Choose from a cleaning routine that is restarted at set intervals and a user-definable weekly program.
Cleaning interval Cleaning cycle = Interval	0-00:01 to 07-00:00 (D-hh:mm) Factory setting 1-00:00	The interval value can be between 1 minute and 7 days. Example: You have set the value "1-00:00". Each day, the cleaning cycle starts at the same time you started the first cleaning cycle.
Daily event times Cleaning cycle = Weekly program	00:00 to 23:59 (HH:MM)	<ol style="list-style-type: none"> 1. Define up to 6 times (Event time 1 ... 6). ↳ You can then choose from these for each weekday afterwards. 2. For each day of the week, individually choose which of the 6 times is to be used for a cleaning routine on this particular day. In this way you create weekly programs that are perfectly adapted to suit your process.
Weekdays Cleaning cycle = Weekly program	Selection Monday ... Sunday	

Other settings and manual cleaning

Menu/Setup/Additional functions/Cleaning/Cleaning 1 ... 4		
Function	Options	Info
Start signal	Selection <ul style="list-style-type: none"> ▪ None ▪ Fieldbus signals ▪ Signals of digital or analog inputs Factory setting None	In addition to cyclic cleaning, you can also use an input signal to start event-controlled cleaning. Choose the trigger for such a cleaning process here. Interval programs and weekly programs are executed as normal, i.e. conflicts can occur. Priority is given to the cleaning program that was the first to be started.
Hold	Selection <ul style="list-style-type: none"> ▪ Off ▪ On Factory setting On	Decide whether there should be a hold during the cleaning process. This hold affects the inputs to which this cleaning process is assigned.
▷ Start single	Action	Start an individual cleaning process with the selected parameters. If cyclical cleaning is enabled, there are times in which it is not possible to manually start the process.
▷ Stop or Stop Failsafe	Action	End the cleaning process (cyclically or manually)
▶ Outputs		Goes to the menu Outputs
▶ Cleaning program assignment view		Shows an overview of the cleaning processes

10.7.4 Mathematical functions

In addition to "real" process values, which are provided by connected physical sensors or analog inputs, mathematical functions can be used to calculate a maximum of 6 "virtual" process values.

The "virtual" process values can be:

- Output via a current output or a fieldbus
- Used as a controlled variable
- Assigned as a measured variable to a limit switch
- Used as a measured variable to trigger cleaning
- Displayed in user-defined measuring menus

Difference

You can subtract the measured values of two sensors and use the result to detect incorrect measurements, for example.

To calculate a difference, you must use two measured values with the same engineering unit.

Menu/Setup/Additional functions/Mathematical functions/MF1 to 6/Mode = Difference		
Function	Options	Info
Calculation	Options <ul style="list-style-type: none"> ■ Off ■ On Factory setting Off	On/off switch for the function
Y1	The options depend on the sensors connected	Select the sensors and the measured variables that should act as the minuend (Y1) or subtrahend (Y2).
Measured value		
Y2		
Measured value		
Difference value	Read only	View this value in a user-defined measuring screen or output the value via the current output.
► Mathematical function assignment view		Overview of the configured functions

Redundancy

Use this function to monitor two or three sensors with redundant measurements. The arithmetic average of the two closest measured values is calculated and output as the redundancy value.

Menu/Setup/Additional functions/Mathematical functions/MF1 to 6/Mode = Redundancy		
Function	Options	Info
Calculation	Options <ul style="list-style-type: none"> ■ Off ■ On Factory setting Off	On/off switch for the function
Y1	The options depend on the sensors connected	You can select a maximum of 3 different types of sensor that output the same measured value. Example for temperature redundancy You have a pH sensor and an oxygen sensor at inputs 1 and 2. Select the pH sensor as Y1 and the oxygen sensor as Y2 . Measured value: In each case select Temperature .
Measured value		
Y2		
Measured value		
Y3 (optional)		
Measured value		

Menu/Setup/Additional functions/Mathematical functions/MF1 to 6/Mode = Redundancy		
Function	Options	Info
Deviation control	Options <ul style="list-style-type: none"> ▪ Off ▪ On Factory setting Off	You can monitor the redundancy. Specify an absolute limit value that may not be exceeded.
Deviation limit	Depends on the selected measured value	
Redundancy	Read only	View this value in a user-defined measuring screen or output the value via the current output.
▶ Mathematical function assignment view		Overview of the configured functions

rH value

To calculate the rH value, a pH sensor and an ORP sensor must be connected. It is irrelevant whether you are using a pH glass sensor, an ISFET sensor or the pH electrode of an ISE sensor.

 Instead of the mathematical functions, you can also connect a combined pH/ORP sensor. Simply set the main measured value to rH (**Setup/**).

Menu/Setup/Additional functions/Mathematical functions/MF1 to 6/Mode = rH calculation		
Function	Options	Info
Calculation	Options <ul style="list-style-type: none"> ▪ Off ▪ On Factory setting Off	On/off switch for the function
pH source	Connected pH sensor	Set the input for the pH sensor and the input for the ORP sensor. Measured value interrogation is obsolete as you must select pH or ORP mV.
ORP source	Connected ORP sensor	
Calculated rH	Read only	View this value in a user-defined measuring screen or output the value via the current output.
▶ Mathematical function assignment view		Overview of the configured functions

Degassed conductivity

Carbon dioxide from the air can be a contributing factor to the conductivity of a medium. The degassed conductivity is the conductivity of the medium excluding the conductivity caused by carbon dioxide.

Advantages of using degassed conductivity taking the example of a power station:

- The conductivity caused by corrosion products or contamination in the feed water is determined as soon as the turbines are started. The system excludes the initially high conductivity values resulting from the ingress of air.
- If carbon dioxide is regarded as non-corrosive, the live steam can be directed to the turbine far earlier during startup.
- If the conductivity value increases during normal operation, it is possible to immediately determine an ingress of coolant or air by calculating the degassed conductivity.

Menu/Setup/Additional functions/Mathematical functions/MF1 to 6/Mode = Degassed conductivity		
Function	Options	Info
Calculation	Options <ul style="list-style-type: none"> ▪ Off ▪ On Factory setting Off	On/off switch for the function
Cation conductivity	Connected conductivity sensor	Cation conductivity is the sensor downstream from the cation exchanger and upstream from the "degassing module", Degassed conductivity is the sensor at the outlet of the degassing module. Measured value interrogation is obsolete as you can only choose conductivity.
Degassed conductivity	Connected conductivity sensor	
CO2 concentration	Read only	View this value in a user-defined measuring screen or output the value via the current output.
▶ Mathematical function assignment view		Overview of the configured functions

Dual conductivity

You can subtract two conductivity values and use the result, for example, to monitor the efficiency of an ion exchanger.

Menu/Setup/Additional functions/Mathematical functions/MF1 to 6/Mode = Dual conductivity		
Function	Options	Info
Calculation	Options <ul style="list-style-type: none"> ▪ Off ▪ On Factory setting Off	On/off switch for the function
Inlet	The options depend on the sensors connected	Select the sensors that should act as the minuend (Inlet , e.g. sensor upstream from the ion exchanger) or subtrahend (Outlet , e.g. sensor downstream from the ion exchanger).
Measured value		
Outlet		
Measured value		
Main value format	Options <ul style="list-style-type: none"> ▪ Auto ▪ # ▪ #.# ▪ #.## ▪ #.### Factory setting Auto	Specify the number of decimal places.
Cond. unit	Options <ul style="list-style-type: none"> ▪ Auto ▪ µS/cm ▪ mS/cm ▪ S/cm ▪ µS/m ▪ mS/m ▪ S/m Factory setting Auto	
Dual conductivity	Read only	View this value in a user-defined measuring screen or output the value via the current output.
▶ Mathematical function assignment view		Overview of the configured functions

Calculated pH value

The pH value can be calculated from the measured values of two conductivity sensors under certain conditions. Areas of application include power stations, steam generators and boiler feedwater.

Menu/Setup/Additional functions/Mathematical functions/MF1 to 6/Mode = pH calculation from conductivity		
Function	Options	Info
Calculation	Options <ul style="list-style-type: none"> ▪ Off ▪ On Factory setting Off	On/off switch for the function
Method	Options <ul style="list-style-type: none"> ▪ NaOH ▪ NH3 ▪ LiOH Factory setting NaOH	The calculation is performed on the basis of Guideline VGB-R-450L of the Technical Association of Large Power Plant Operators (Verband der Großkesselbetreiber, (VGB)). NaOH $pH = 11 + \log \{(\kappa_v - 1/3 \kappa_n)/273\}$ NH3 $pH = 11 + \log \{(\kappa_v - 1/3 \kappa_n)/243\}$ LiOH $pH = 11 + \log \{(\kappa_v - 1/3 \kappa_n)/228\}$ κ_v ... Inlet ... direct conductivity κ_n ... Outlet ... acid conductivity
Inlet	The options depend on the sensors connected	Inlet Sensor upstream from the cation exchanger, "direct conductivity" Outlet Sensor downstream from the cation exchanger, "acid conductivity" The choice of measured value is obsolete since it must always be Conductivity .
Measured value		
Outlet		
Measured value		
Calculated pH	Read only	View this value in a user-defined measuring screen or output the value via the current output.
► Mathematical function assignment view		Overview of the configured functions

Formula (optional, with activation code)

With the formula editor, it is possible to calculate a new value from a maximum of 3 measured values. A wide range of mathematical and logical (Boolean) operations are available for this purpose.

 The Liquiline firmware offers you a powerful mathematics tool with the formula editor. You are responsible for the feasibility of your formula, and therefore of the result.

Symbol	Operation	Type of operands	Type of result	Example
+	Addition	Numerical	Numerical	A+2
-	Subtraction	Numerical	Numerical	100-B
*	Multiplication	Numerical	Numerical	A*C
/	Division	Numerical	Numerical	B/100
^	Power	Numerical	Numerical	A^5
²	Square	Numerical	Numerical	A²
³	Cube	Numerical	Numerical	B³

Symbol	Operation	Type of operands	Type of result	Example
SIN	Sine	Numerical	Numerical	SIN(A)
COS	Cosine	Numerical	Numerical	COS(B)
EXP	Exponential function e^x	Numerical	Numerical	EXP(A)
LN	Natural logarithm	Numerical	Numerical	LN(B)
LOG	Decadic logarithm	Numerical	Numerical	LOG(A)
MAX	Maximum of two values	Numerical	Numerical	MAX(A,B)
MIN	Minimum of two values	Numerical	Numerical	MIN(20,B)
ABS	Absolute value	Numerical	Numerical	ABS(C)
NUM	Boolean → numerical conversion	Boolean	Numerical	NUM(A)
=	Equals	Boolean	Boolean	A=B
<>	Not equal to	Boolean	Boolean	A<>B
>	Greater than	Numerical	Boolean	B>5.6
<	Less than	Numerical	Boolean	A<C
OR	Disjunction	Boolean	Boolean	B OR C
AND	Conjunction	Boolean	Boolean	A AND B
XOR	Exclusive disjunction	Boolean	Boolean	B XOR C
NOT	Negation	Boolean	Boolean	NOT A

Menu/Setup/Additional functions/Mathematical functions/MF1 to 6/Mode = Formula		
Function	Options	Info
Calculation	Options <ul style="list-style-type: none"> ▪ Off ▪ On Factory setting Off	On/off switch for the function
Source A ... C	Options Select source Factory setting None	You can use all the sensor inputs, binary and analog inputs, mathematical functions, limit switches, fieldbus signals, controllers and data records for measuring range switching as the source for measured values.
Measured value	Options Depends on the source	
A ... C	The current measured value is displayed	<ol style="list-style-type: none"> 1. Choose a maximum of three sources (A, B and C) for measured values. 2. For each source, choose the measured value to be calculated. <ul style="list-style-type: none"> ↳ All available signals - depending on the selected source - are possible measured values. 3. Enter the formula. 4. Switch on the calculation function. <ul style="list-style-type: none"> ↳ The current measured values A, B and C as well as the result of the calculation using the formula are displayed.
Formula	Free text	Table → 106  Make sure the exact notation is used (upper case). Blank spaces before and after mathematical characters are irrelevant. Note the operator precedence, i.e. multiplication and division have priority before addition and subtraction. Use parentheses if necessary.

Menu/Setup/Additional functions/Mathematical functions/MF1 to 6/Mode = Formula		
Function	Options	Info
Result unit	Free text	Optionally, enter a unit for the calculated value.
Result format	Options <ul style="list-style-type: none"> ■ # ■ #.# ■ #.## ■ #.### ■ #.#### Factory setting #.##	Select the number of decimal places.
Result decimal	Read only	Current, calculated value
► Mathematical function assignment view		Overview of the configured functions

Example: 2-point chlorine regulator with volume flow monitoring

A relay output activates a dosing pump. The pump should switch on when the following 3 conditions are met:

- (1) There is flow
- (2) The volume flow is above a defined value
- (3) The concentration of chlorine drops below a defined value

1. Connect a binary input signal from an "INS" point level switch of the CCA250 assembly to the DIO module.
2. Connect an analog input signal of a volume flow meter to the AI module.
3. Connect the chlorine sensor.
4. Configure the mathematical function **Formula** : **Source A** = DIO binary input, **Source B** = AI current input, **Source C** = input **Disinfection**.
 - ↳ Formula:
 $A \text{ AND } (B > 3) \text{ AND } (C < 0.9)$
 (where 3 is the lower limit value of the volume flow and 0.9 is the lower limit value of the chlorine concentration)
5. Configure the relay output with the mathematical function **Formula** and connect the dosing pump to the corresponding relay.

The pump is switched on if all 3 conditions are met. If one of the conditions is no longer met, the pump is switched off again.

ⓘ Instead of outputting the result of the formula directly to a relay, you can also connect a limit switch in between in order to attenuate the output signal via a switch-on and switch-off delay.

Example: Load-based control

The load - i.e. the product of the concentration and volume flow - is needed for the dosage of precipitants, for instance.

1. Connect the input signal of a phosphate analyzer to the AI module.
2. Connect an analog input signal of a volume flow meter to the AI module.
3. Configure the mathematical function **Formula** : **Source A** = phosphate input signal and **Source B** = volume flow input signal.
 - ↳ Formula:
 $A * B * x$
 (where x is an application-specific proportionality factor)
4. Select this formula as the source e.g. of the current output or of a modulated binary output.

5. Connect the valve or pump.

11 Diagnostics and troubleshooting

11.1 General troubleshooting

The analyzer continuously monitors its functions itself.

If a diagnostic message occurs, the display alternates between the diagnostic message and the measured value in the measuring mode.

The color of the display background changes to red if a diagnostic message for error category "F" occurs.

11.1.1 Troubleshooting

A diagnostic message appears on the display or via the fieldbus of the Liquiline System analyzer, measured values are not plausible, or you identify a fault.

1. See the Diagnostics menu for the details on the diagnostic message.
 - ↳ Follow the instructions to rectify the problem.
2. If this does not help: search for the diagnostic message under "Overview of diagnostic information" in these Operating Instructions. Use the message number as a search criterion. Ignore the letters indicating the Namur error category.
 - ↳ Follow the troubleshooting instructions provided in the last column of the error tables.
3. If the measured values are implausible, the local display is faulty or you encounter other problems, search for the faults under "Process errors without messages" (→ Operating Instructions for Memosens, BA01245C) or "Device-specific errors" ().
 - ↳ Follow the recommended measures.
4. Contact the Service Department if you cannot rectify the error yourself. Only cite the error number.

11.1.2 Process errors without messages

 Operating Instructions "Memosens", BA01245C

11.1.3 Device-specific errors

Problem	Possible cause	Tests and/or remedial measures
Dark display	No supply voltage	Check if supply voltage applied.
	Base module defective	Replace base module
Values appear on display but: <ul style="list-style-type: none"> ▪ Display does not change and / or ▪ Device cannot be operated 	Module not wired correctly	Check modules and wiring.
	Impermissible operating system condition	Switch off device and switch it on again.
Implausible measured values	Inputs defective	First perform tests and take measures as outlined in "Process-specific errors" section Measuring input test: ▶ Connect the Memocheck Sim CYP03D to the input and use it to check the function of the input.
	Calibration / adjustment failed	Repeat the calibration
	No reagents / sample	<ul style="list-style-type: none"> ▪ Check levels ▪ Check the hoses of the reagents ▪ Check sample (only if self-priming)

Problem	Possible cause	Tests and/or remedial measures
	Cell dirty	<ul style="list-style-type: none"> ■ Calibration with zero standard ■ Clean via manual cleaning, then repeat calibration with zero standard
	Incorrect reagent	Check the configured measuring parameters and the reagents used
	Incorrect concentration of the standard solution	Check the concentration settings for the standard solution
	Reagents have passed their shelf life	
	Incorrect hose system	Check the hose system using the hose routing diagram (see "Commissioning" section).
Measurement//calibration does not start	Action still active	
	Appropriate bottles not used	Check status
	No sample available	Level detection (only for devices with sample collecting vessel)
	Device is in the fieldbus mode; no manual actions are possible	
	Injector run times have elapsed	
Calibration has failed	Stability criterion was not met	<ul style="list-style-type: none"> ■ Check the configuration and perform manual calibration again ■ Check the hoses of the reagents
Current output, incorrect current value	Incorrect adjustment	Check with integrated current simulation, connect mA meter directly to current output.
	Load too large	
	Shunt / short to ground in current loop	
No current output signal	Base module defective	Check with integrated current simulation, connect mA meter directly to current output.

11.2 Diagnostic information on local display

Up-to-date diagnostic events are displayed along with their status category, diagnostic code and short text. Clicking on the navigator lets you retrieve more information and tips on remedial measures.

11.3 Diagnostic information via web browser

The same information as for the local display is available via the web server.

11.4 Diagnostic information via fieldbus

Diagnostic events, status signals and more information are transmitted according to the definitions and technical capability of the respective fieldbus systems.

11.5 Adapting the diagnostic information

11.5.1 Classification of diagnostic messages

In the **DIAG/Diagnostics list** menu you can find more detailed information on the current diagnostic messages displayed.

In accordance with Namur specification NE 107, the diagnostic messages are characterized by:

- Message number
- Error category (letter in front of the message number)
 - **F** = (Failure) a malfunction has been detected
The measured value of the affected channel is no longer reliable. The cause of the malfunction is to be found in the measuring point. Any control system connected should be set to manual mode.
 - **C** = (Function check), (no error)
Maintenance work is being performed on the device. Wait until the work has been completed.
 - **S** = (Out of specification), the measuring point is being operated outside its specification
Operation is still possible. However, you run the risk of increased wear, shorter operating life or lower measurement accuracy. The cause of the problem is to be found outside the measuring point.
 - **M** = (Maintenance required), action should be taken as soon as possible
The device still measures correctly. Immediate measures are not necessary. However, proper maintenance efforts would prevent a possible malfunction in the future.
- Message text

 If you contact the Service Department, please cite the message number only. Since you can individually change the assignment of an error to an error category, the Service Department cannot use this information.

11.5.2 Adapting the diagnostic behavior

All the diagnostic messages are assigned to specific error categories at the factory. Since other settings might be preferred depending on the application, error categories and the effect errors have on the measuring point can be configured individually. Furthermore, every diagnostic message can be disabled.

Example

Diagnostic message 531 **Logbook full** appears on the display. You want to change this message so that an error is not shown on the display for example.

1. For analyzer-specific diagnostic messages, select **Menu/Setup/Analyzer/Extended setup/Diagnostics settings/Diag. behavior** and for sensor-related messages, select **Menu/Setup/Inputs/<Sensor>/Extended setup/Diagnostics settings/Diag. behavior**.
2. Select the diagnostic message and press the navigator button.
3. Decide: (a) Should the message be deactivated? (**Diagnostics message = Off**)
(b) Do you want to change the error category? (**Status signal**)
(c) Should an error current be output? (**Error current = On**)
(d) Do you want to trigger a cleaning program? (**Cleaning program**)
4. Example: You deactivate the message.
 - ↳ The message is no longer displayed. In the **DIAG** menu, the message appears as **Past message**.

Possible settings

The list of diagnostic messages displayed depends on the path selected. There are device-specific messages, and messages that depend on what sensor is connected.

Menu/Setup/./Extended setup/Diagnostics settings/Diag. behavior		
Function	Options	Info
List of diagnostic messages		Select the message to be changed. Only then can you make the settings for this message.
Diag. code	Read only	
Diagnostic message	Selection <ul style="list-style-type: none"> ▪ Off ▪ On Factory setting Depends on the Diag. code	You can deactivate or reactivate a diagnostic message here. Deactivating means: <ul style="list-style-type: none"> ▪ No error message in the measuring mode ▪ No error current at the current output
Error current	Selection <ul style="list-style-type: none"> ▪ Off ▪ On Factory setting Depends on the Diag. code	Decide whether an error current should be output at the current output if the diagnostic message display is activated. In the event of general device errors, the error current is switched to all the current outputs. In the event of channel-specific errors, the error current is only switched to the current output in question.
Status signal	Selection <ul style="list-style-type: none"> ▪ Maintenance (M) ▪ Out of specification (S) ▪ Function check (C) ▪ Failure (F) Factory setting Depends on the Diag. code	The messages are divided into different error categories in accordance with NAMUR NE 107. Decide whether you want to change a status signal assignment for your application.
Diag. output	Selection <ul style="list-style-type: none"> ▪ None ▪ Binary outputs ▪ Alarm relay ▪ Relay1 to n (depends on the device version) Factory setting None	You can use this function to select an output to which the diagnostic message should be assigned.  An alarm relay is always available, regardless of the device version. Other relays are optional. For sensors with the Memosens protocol: Before you can assign the message to an output: Configure one of the output types mentioned as follows: Menu/Setup/Outputs/(Alarm relay or Binary output or relay)/Function = Diagnostics and Operating mode = as assigned.
Cleaning program	Selection <ul style="list-style-type: none"> ▪ None ▪ Cleaning 1 ... 4 Factory setting None	Decide whether the diagnostic message should trigger a cleaning program. You can define cleaning programs under: Menu/Setup/Additional functions/Cleaning.
► Detail information	Read only	Here you can find more information on the diagnostic message and instructions on how to resolve the problem.

11.6 Overview of diagnostic information

11.6.1 Device-specific, general diagnostic messages

No.	Message	Factory settings			Tests or remedial action
		S ¹⁾	D ²⁾	F ³⁾	
202	Selftest active	F	On	Off	Wait for self-test to be finished
216	Hold active	C	On	Off	Output values and status of the channel are on hold
241	Firmware failure	F	On	On	Internal device error <ol style="list-style-type: none"> 1. Update the software 2. Contact the Service Department 3. Replace the backplane (Service)
242	Firmware incomp.	F	On	On	
243	Firmware failure	F	On	On	
261	Electronics module	F	On	On	Electronics module defective <ol style="list-style-type: none"> 1. Replace the module 2. Contact the Service Department
262	Module connection	F	On	On	Electronics module not communicating <ol style="list-style-type: none"> 1. Check the module , replace it if necessary 2. Contact the Service Department
263	Incomp. detected	F	On	On	Wrong kind of electronics module <ol style="list-style-type: none"> 1. Replace the module 2. Contact the Service Department
284	Firmware update	M	On	Off	Update completed successfully
285	Update error	F	On	On	Firmware update failed <ol style="list-style-type: none"> 1. Repeat 2. SD card error → use another card 3. Incorrect firmware → repeat with suitable firmware 4. Contact the Service Department
302	Battery low	M	On	Off	Buffer battery of real time clock is low The date and time are lost if the power is interrupted. <ul style="list-style-type: none"> ▶ Contact the Service Department (battery replacement)
304	Module data	F	On	On	At least 1 module has incorrect configuration data <ol style="list-style-type: none"> 1. Check the system information 2. Contact the Service Department
305	Power consumption	F	On	On	Total power consumption too high <ol style="list-style-type: none"> 1. Check installation 2. Remove sensors/modules
306	Software error	F	On	On	Internal firmware error <ul style="list-style-type: none"> ▶ Contact the Service Department
335	Fan defective	F	On	On	Ventilator defective <ol style="list-style-type: none"> 1. Replace the ventilator 2. Contact the Service Department

No.	Message	Factory settings			Tests or remedial action
		S ¹⁾	D ²⁾	F ³⁾	
337	Pump hose warning	M	On	Off	End of pump hose service life will be reached shortly Displayed under Menu/Diagnostics/Operating time information/Pump tube life 1. Schedule replacement 2. After replacement, reset the operating time under Menu/Diagnostics/Operating time information
360	Cooling/Heating	C	On	Off	Temperature range in the housing exceeded 1. Check installation conditions and the ambient temperature 2. Replace the FMAB1 module 3. Contact the Service Department
361	Cooling/Heating	F	On	On	Cooling/heating module defective Defined temperature range not reached. This could affect the functionality of the reagents. 1. Check whether the insulation cap is seated correctly over the reagents 2. Replace cooling/heating module 3. Contact the Service Department
362	Photometer temp.	F	On	Off	Temperature of the photometer too high ▶ Contact the Service Department
363	Photometer temp.	F	On	Off	Temperature of the photometer too low ▶ Contact the Service Department
364	Timeout dosing	F	On	On	The liquid manager/linear drive has timed out. Possible reasons: ▪ Photoelectric barrier defective ▪ Blocking ▶ Contact the Service Department
365	Photometer comm.	F	On	On	Photometer not communicating Possible reasons: Incorrect photometer connection 1. Check photometer connection 2. Contact the Service Department
367	Module connect.	F	On	On	No communication to sample preparation ▶ Check connecting cable to sample preparation system
370	Internal voltage	F	On	On	Internal voltage outside the valid range ▶ Check supply voltage
373	Electronic temp. high	M	On	Off	High electronics temperature ▶ Check ambient temperature and energy consumption
374	Sensor check	F	On	Off	No measurement signal from sensor 1. Check sensor connection 2. Check sensor, replace if necessary

No.	Message	Factory settings			Tests or remedial action
		S ¹⁾	D ²⁾	F ³⁾	
380	Firmware failure	F	On	On	Internal software error <ol style="list-style-type: none"> 1. Update the software 2. Replace backplane 3. Contact the Service Department and quote the number displayed
401	Factory reset	F	On	On	Factory reset is performed
405	Service IP active	C	Off	Off	Service switch is switched on The device can be addressed at 192.168.1.212. <ul style="list-style-type: none"> ▶ Switch off the service switch to change to the saved IP settings
406	Param. active	C	Off	Off	▶ Wait for configuration to be finished
407	Diag. setup active	C	Off	Off	▶ Wait for maintenance to be finished
412	Writing backup	F	On	Off	▶ Wait for the write process to be finished
413	Reading backup	F	On	Off	▶ Wait
460	Output below limit	S	On	Off	Reasons <ul style="list-style-type: none"> ▪ Sensor in air ▪ Air pockets in assembly ▪ Sensor fouled ▪ Incorrect flow to sensor <ol style="list-style-type: none"> 1. Check sensor installation 2. Clean sensor 3. Adjust assignment of current outputs
461	Output above limit	S	On	Off	
502	No text catalog	F	On	On	▶ Contact the Service Department
503	Language change	M	On	Off	Language change failed <ul style="list-style-type: none"> ▶ Contact the Service Department
529	Diag. setup active	C	Off	Off	▶ Wait for maintenance to be finished.
530	Logbook at 80%	M	On	Off	<ol style="list-style-type: none"> 1. Save the logbook to the SD card and then delete the logbook in the device 2. Set memory to ring memory 3. Deactivate logbook
531	Logbook full	M	On	Off	
532	License error	M	On	Off	▶ Contact the Service Department
540	Parameter save fail	M	On	Off	Storage of configuration has failed <ul style="list-style-type: none"> ▶ Repeat
541	Parameter load ok	M	On	Off	Configuration successfully loaded
542	Parameter load fail	M	On	Off	Loading of configuration has failed <ul style="list-style-type: none"> ▶ Repeat
543	Parameter load abort	M	On	Off	Configuration loading aborted
544	Parameter reset ok	M	On	Off	Factory default successful
545	Parameter reset fail	M	On	Off	Setting of device configuration to factory setting has failed
565	Configuration	M	On	Off	Invalid configuration of sample preparation system <ol style="list-style-type: none"> 1. In Setup/Sample preparation check the number of channels used and their operating mode and installation type. 2. Check the permitted combinations of sample preparation and analyzers, see the Operating Instructions for the sample preparation system.

No.	Message	Factory settings			Tests or remedial action
		S ¹⁾	D ²⁾	F ³⁾	
714	Filter mats change	M	On	Off	Filter mat change necessary The limit value for operating hours has been exceeded <ul style="list-style-type: none"> ▶ Replace the filter mats and reset the operating hours counter in the Diagnostics menu
715	Calibration expired	M	On	Off	The validity of the last calibration has expired. The date of the last calibration is too far in the past. Measurement can still take place. Possible reasons: Manual intervention has prevented automatic calibration <ol style="list-style-type: none"> 1. Calibrate analyzer manually 2. Check device configuration
716	Calibration expired	S	On	Off	Calibration has failed or is not reliable Possible reasons: Stability criteria are not met <ol style="list-style-type: none"> 1. Check the configuration and perform a manual calibration again 2. Contact the Service Department
717	Photometer defective	F	On	On	Photometer defective Possible reasons: <ul style="list-style-type: none"> ▪ No LED voltage ▪ No LED current <ul style="list-style-type: none"> ▶ Contact the Service Department
718	Cuvette covering	M	On	Off	Photometer check High degree of contamination - reliable measurement will not be possible soon <ol style="list-style-type: none"> 1. Clean analyzer manually 2. Contact the Service Department
719	Cuvette covering	F	On	Off	Photometer check buildup, high degree of contamination - measurement no longer possible <ol style="list-style-type: none"> 1. Start cleaning 2. Contact the Service Department
726	Liquids warning	M	On	Off	Consumable liquids, warning Measurement can still take place. Possible reasons <ul style="list-style-type: none"> ▪ The level of one or more liquids is low ▪ One or more liquids almost past their shelf life. <ul style="list-style-type: none"> ▶ Top up/replace liquids in question and reset counter in Diagnostics/Operating time information
727	Liquids alarm	F	On	Off	Consumable liquids, alarm Measurement can still take place. Possible reasons <ul style="list-style-type: none"> ▪ The level of one or more liquids is low ▪ One or more liquids past their shelf life. <ul style="list-style-type: none"> ▶ Top up/replace liquids in question and reset counter in Diagnostics/Operating time information

No.	Message	Factory settings			Tests or remedial action
		S ¹⁾	D ²⁾	F ³⁾	
729	Filter candle change	M	On	Off	<ul style="list-style-type: none"> ▪ Filter cartridge needs replacement ▪ The limit value for operating hours has been exceeded ▶ Replace the filter cartridge for the sample preparation system and reset the operating hours counter in the Diagnostics menu
730	Cleaning solution	M	On	Off	<ul style="list-style-type: none"> ▪ Level warning for cleaner of sample preparation system ▪ Depending on the duration of cleaning, the cleaning interval and external events, the remaining quantity is sufficient for a few hours or days <ol style="list-style-type: none"> 1. Top up cleaner for the sample preparation system 2. Check the level switch for the cleaning solution
731	Leakage sensor	F	On	Off	<p>Leak detected in the sample preparation system or analyzer</p> <ol style="list-style-type: none"> 1. Check hoses and connections 2. Check solenoid valves 3. Check leakage sensor 4. Check the free outlet on the analyzer 5. Replace defective parts and, if necessary, reset the operating hours counters in the Diagnostics menu
732	Wear parts alarm	F	On	On	<p>One or more wear parts has exceeded its service life.</p> <ul style="list-style-type: none"> ▶ Replace the wear parts in question and reset the counter in Diagnostics/Operating time information .
733	Wear parts warning	M	On	Off	<p>One or more wear parts has almost reached the end of its service life.</p> <ul style="list-style-type: none"> ▶ Replace the wear parts in question and reset the counter in Diagnostics/Operating time information .
906	Cat.exchanger failure	F	On	Off	<p>Invalid values for conductivity or flow</p> <ol style="list-style-type: none"> 1. Check for valid measured values in the menu of the mathematical function. 2. Check sensors. 3. Check minimum flow.
907	Cat.exchanger warning	S	On	Off	<p>Limit values exceeded for conductivity or flow. Possible reasons:</p> <ul style="list-style-type: none"> ▪ Resin depleted ▪ Blocked pipe ▶ Check application.
908	IEX capacity low	M	On	Off	<p>The capacity of the exchange resin will soon be exhausted.</p> <ul style="list-style-type: none"> ▶ Schedule resin regeneration or replacement.
909	IEX capacity exhausted	F	On	Off	<p>The capacity of the exchange resin is exhausted.</p> <ul style="list-style-type: none"> ▶ Regenerate or replace the resin.
910	Limit switch	S	On	Off	<p>Limit switch activated</p>

No.	Message	Factory settings			Tests or remedial action
		S ¹⁾	D ²⁾	F ³⁾	
930	No sample	F	On	On	Sample flow interrupted during aspiration <ul style="list-style-type: none"> ▪ Suction line blocked or leaking ▪ No inflow of sample <ol style="list-style-type: none"> 1. Check suction line and suction strainer 2. Check inflow of sample
931	Sampling time	M	On	Off	Standard pumping time exceeded <ul style="list-style-type: none"> ▪ Filter cartridge clogged ▪ Sample line partially blocked <ol style="list-style-type: none"> 1. Clean the filter cartridge 2. Clean the sample line 3. Replace the filter or sample line
936	Temp. range exceeded	S	On	Off	Outside temperature for sample preparation system out of specification <ol style="list-style-type: none"> 1. Check application 2. Check temperature sensor 3. Check configuration of the temperature sensor, sample preparation system and the heating
937	Controlled variable	S	On	Off	Controller input warning Status of the controller variable is not OK <ul style="list-style-type: none"> ▶ Check application
938	Controller setpoint	S	On	Off	Controller input warning Status of set point is not OK <ul style="list-style-type: none"> ▶ Check application
939	Control. disturbance	S	On	Off	Controller input warning Status of disturbance variable is not OK <ul style="list-style-type: none"> ▶ Check application
940	Process value	S	On	Off	Measured value out of specification Uncertain measured value. <ol style="list-style-type: none"> 1. Change the measuring range 2. Calibrate the system
941	Process value	F	On	On	Measured value out of specification Invalid measured value. <ol style="list-style-type: none"> 1. Change the measuring range 2. Calibrate the system
951 - 958	Hold active CH1 ..	C	On	Off	Output values and status of the channels are on hold. Wait until the hold is released again.
961 - 968	Diagnostic module 1 (961) ... Diagnostic module 8 (968)	S	Off	Off	Diagnostic module is enabled
969	Modbus Watchdog	S	Off	Off	The device did not receive a Modbus telegram from the master within the specified time. The status of Modbus process values received is set to invalid
970	Curr. input overload	S	On	On	Current input overloaded The current input is switched off from 23 mA due to overload and reactivated automatically when a normal load is present.

No.	Message	Factory settings			Tests or remedial action
		S ¹⁾	D ²⁾	F ³⁾	
971	Current Input low	S	On	On	Current input too low At 4 to 20 mA, the input current is less than the lower error current. ► Check the input for short-circuiting
972	Curr. input > 20 mA	S	On	On	Current output range exceeded
973	Current Input < 4 mA	S	On	On	Current output range undershot
974	Diagnostics confirm.	C	Off	Off	User has acknowledged the message displayed in the measuring menu.
975	Device restart	C	Off	Off	Device reset
976	PFM value high	S	On	Off	Pulse frequency modulation: output signal exceeded/undershot. Measured value outside the specified range. <ul style="list-style-type: none"> ■ Sensor in air ■ Air pockets in assembly ■ Incorrect flow to sensor ■ Sensor fouled <ol style="list-style-type: none"> 1. Clean sensor 2. Check plausibility 3. Adjust the PFM configuration
977	PFM value low	S	On	Off	
978	ChemoClean Failsafe	S	On	On	No feedback signal detected within the configured period. <ol style="list-style-type: none"> 1. Check the application 2. Check the wiring 3. Extend the duration
990	Deviation limit	F	On	On	Redundancy: limit value of percentage deviation exceeded
991	CO ₂ conc. range	F	On	On	CO ₂ concentration (degassed conductivity) outside the measuring range
992	pH calculation range	F	On	On	pH calculation outside the measuring range
993	rH calculation range	F	On	On	rH calculation outside the measuring range
994	Difference conduct.	F	On	On	Dual conductivity outside the measuring range
995	Mathematical error	S	On	On	Incorrect calculation result <ol style="list-style-type: none"> 1. Check the mathematical functions. 2. Check the input variables.

- 1) **Status signal**
2) **Diagnostic message**
3) **Error current**

11.6.2 Sensor-specific diagnostic messages

 Operating Instructions "Memosens", BA01245C

11.7 Pending diagnostic messages

The Diagnostics menu contains all the information on the device status. Furthermore, various service functions are available.

The following messages are directly displayed every time you enter the menu:

- Most important message
Diagnostic message recorded with the highest criticality level
- Past message
Diagnostic message whose cause is no longer present.

All the other functions in the Diagnostics menu are described in the following chapters.

 If diagnostic message M313 **Liquidsensor** appears five times in succession when running a program, the active program is aborted for reasons of safety. This behavior on the part of the device cannot be altered by deactivating the diagnostic message under **Menu/Setup/General settings/Extended setup/Diagnostics settings/Diag. behavior** .

11.8 Diagnostics list

All the current diagnostic messages are listed here.

A time stamp is available for each message. Furthermore, the user also sees the configuration and description of the message as saved in **Menu/Setup/General settings/Extended setup/Diagnostics settings/Diag. behavior** .

11.9 Logbooks

11.9.1 Available logbooks

Types of logbooks

- Logbooks physically available (all apart from the overall logbook)
- Database view of all logbooks (=overall logbook)

Logbook	Visible in	Max. entries	Can be disabled ¹⁾	Logbook can be deleted	Entries can be deleted	Can be exported
Overall logbook	All events	20000	Yes	No	Yes	No
Calibration logbook	Calibration events	75	(Yes)	No	Yes	Yes
Operation logbook	Configuration events	250	(Yes)	No	Yes	Yes
Diagnostics logbook	Diagnostic events	250	(Yes)	No	Yes	Yes
Analyzer event logbook	Analyzer events	19500 ²⁾	No	No	Yes	Yes
Analyzer calibration logbook	Analyzer calibration logbook	250	(Yes)	No	Yes	Yes
Analyzer data logbook	Analyzer data logbooks	20000 ²⁾	No	No	Yes	Yes
Analyzer absorbance data logbook	Absorption data logbook	5000	No	No	Yes	Yes
Analyzer raw values logbook	Raw data logbook	5000	No	No	Yes	Yes
Version logbook	All events	50	No	No	No	Yes
Hardware version logbook	All events	125	No	No	No	Yes

Logbook	Visible in	Max. entries	Can be disabled ¹⁾	Logbook can be deleted	Entries can be deleted	Can be exported
Data logbook for sensors (optional)	Data logbooks	150 000	Yes	Yes	Yes	Yes
Debugging logbook	Debug events (only accessible by entering the special service activation code)	1000	Yes	No	Yes	Yes

- 1) Data in brackets means this depends on the overall logbook
 2) Suffices for 1 year of operation with a usual measuring interval

11.9.2 Menu Logbooks

DIAG/Logbooks		
Function	Options	Info
▶ All events		Chronological list of all the logbook entries, with information on the type of event
▶ Show	Events are displayed	Select a particular event to display more detailed information.
▶ Go to date	User entry <ul style="list-style-type: none"> ▪ Go to date ▪ Time 	Use this function to go directly to a specific time in the list. In this way, you avoid having to scroll through all the information. The complete list is always visible, however.
▶ Calibration events		Chronological list of the calibration events
▶ Show	Events are displayed	Select a particular event to display more detailed information.
▶ Go to date	User entry <ul style="list-style-type: none"> ▪ Go to date ▪ Time 	Use this function to go directly to a specific time in the list. In this way, you avoid having to scroll through all the information. The complete list is always visible, however.
▷ Delete all entries	Action	You can delete all the calibration logbook entries here.
▶ Configuration events		Chronological list of the configuration events.
▶ Show	Events are displayed	Select a particular event to display more detailed information.
▶ Go to date	User entry <ul style="list-style-type: none"> ▪ Go to date ▪ Time 	Use this function to go directly to a specific time in the list. In this way, you avoid having to scroll through all the information. The complete list is always visible, however.
▷ Delete all entries	Action	You can use this to delete all the operation logbook entries.
▶ Diagnostic events		Chronological list of the diagnostics events
▶ Show	Events are displayed	Select a particular event to display more detailed information.
▶ Go to date	User entry <ul style="list-style-type: none"> ▪ Go to date ▪ Time 	Use this function to go directly to a specific time in the list. In this way, you avoid having to scroll through all the information. The complete list is always visible, however.
▷ Delete all entries	Action	You can use this to delete all the diagnostics logbook entries.

DIAG/Logbooks		
Function	Options	Info
▶ Analyzer events		Entries for analyzer events, such as measurement, cleaning, calibration.
▶ Show	Events are displayed	Select a particular event to display more detailed information.
▶ Go to date	User entry <ul style="list-style-type: none"> ▪ Go to date ▪ Time 	Use this function to go directly to a specific time in the list. In this way, you avoid having to scroll through all the information. The complete list is always visible, however.
▷ Delete all entries	Action	You can use this to delete all analyzer event entries.

You can view your data logbook entries graphically on the display (**Show plot**).

You can also adapt the display to suit your individual requirements:

- Press the navigator button in the graphic display: you are given additional options such as the zoom function and x/y movement of the graph.
- Define the cursor: if you select this option, you can move along the graph with the navigator and view the logbook entry (data stamp/measured value) in text form for every point in the graph.
- Simultaneous display of two logbooks: **Select 2nd plot** and **Show plot**
 - A small cross marks the currently selected graph for which the zoom can be changed or a cursor used, for example.
 - In the context menu (press the navigator button), you can select the other graph. You can then apply the zoom function, a movement or a cursor to this graph.
 - Using the context menu, you can also select both graphs simultaneously. This enables you, for example, to use the zoom function on both graphs simultaneously.

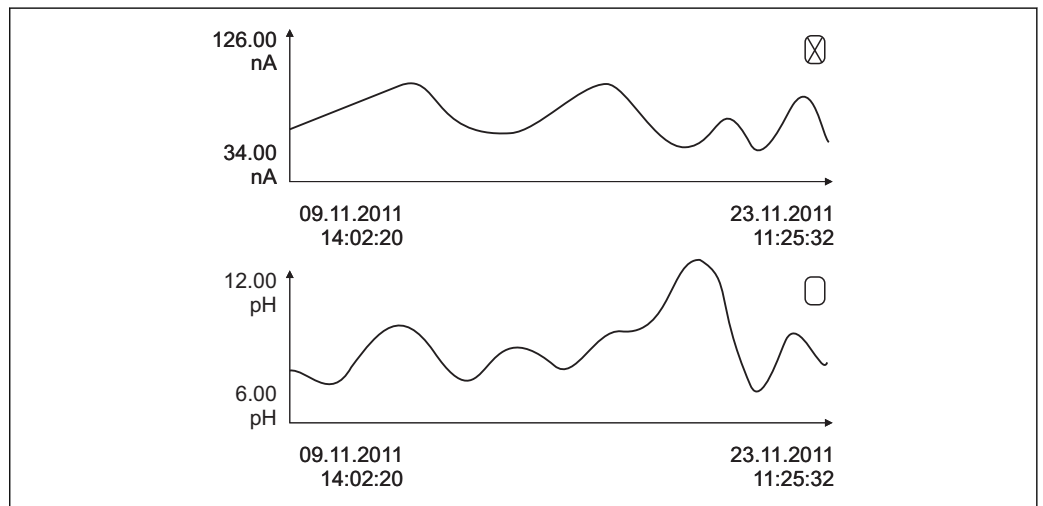

72 Simultaneous display of two graphs, the upper one is "selected"

A0016688

DIAG/Logbooks		
Function	Options	Info
▶ Analyzer data logbooks		Data logbooks for the data of the wet-chemical analyzers
▶ Data logbook SP1		In the case of two-channel devices, data logbook SP2 is also displayed
Source of data	Read only	Displays the measuring channel
Measuring parameter	Read only	Displays the measuring parameter that is being recorded
Unit	Read only	Displays the unit
▶ Show	Events are displayed	Select a particular event to display more detailed information.
▶ Go to date	User entry <ul style="list-style-type: none"> ▪ Go to date ▪ Time 	Use this function to go directly to a specific time in the list. In this way, you avoid having to scroll through all the information. The complete list is always visible, however.
▶ Show plot	Graphic display of the logbook entries	The entries are displayed according to your settings in the General settings/Logbooks .
Select 2nd plot	Select another data logbook	You can view a second logbook at the same time as the current one.
▷ Delete all entries	Action	You can use this to delete all data logbook entries.
▶ Absorption data logbook		
Curve	Read only	Displays the selected LED
▶ Show	Events are displayed	Select a particular event to display more detailed information.
▶ Go to date	User entry <ul style="list-style-type: none"> ▪ Go to date ▪ Time 	Use this function to go directly to a specific time in the list. In this way, you avoid having to scroll through all the information. The complete list is always visible, however.
▶ Show plot	Graphic display of the logbook entries	The entries are displayed according to your settings in the General settings/Logbooks .
▷ Delete all entries	Action	You can delete all the absorption data logbook entries here.
▶ Raw data logbook		
▶ Show	Events are displayed	Select a particular event to display more detailed information.
▶ Show plot	Graphic display of the logbook entries	The entries are displayed according to your settings in the General settings/Logbooks .

DIAG/Logbooks		
Function	Options	Info
▶ Set plotting window range		Here you can specify the start and end times of the logbook entries to be displayed graphically.
Plotter begin	Selection <ul style="list-style-type: none"> ▪ First entry ▪ Date/Time Factory setting First entry	<ul style="list-style-type: none"> ▪ First entry: Defines the first entry saved in the logbook as the start time. ▪ Date/Time: Defines the set date/time as the start time.
Plotter end	Selection <ul style="list-style-type: none"> ▪ Last entry ▪ Date/Time Factory setting Last entry	<ul style="list-style-type: none"> ▪ First entry: Defines the last entry saved in the logbook as the end time. ▪ Date/Time: Defines the set date/time as the end time.
▶ Show plot	Graphic display of the logbook entries	The entries are displayed according to your settings in the General settings/Logbooks .
▷ Delete all entries	Action	You can delete all the absorption data logbook entries here.
▶ Data logbooks		Chronological list of the data logbook entries for sensors
Data logbook 1 ... 8 <Logbook name>		This submenu is available for each data logbook that you have set up and activated.
Source of data	Read only	Input or mathematical function is displayed
Measured value	Read only	Measured value being recorded is displayed
Log time left	Read only	Display of days, hours and minutes until logbook is full. Pay attention to the information on selecting the memory type in the General settings/Logbooks .
▶ Show	Events are displayed	Select a particular event to display more detailed information.
▶ Go to date	User entry <ul style="list-style-type: none"> ▪ Go to date ▪ Time 	Use this function to go directly to a specific time in the list. In this way, you avoid having to scroll through all the information. The complete list is always visible, however.
▶ Show plot	Graphic display of the logbook entries	The entries are displayed according to your settings in the General settings/Logbooks .
Select 2nd plot	Select another data logbook	You can view a second logbook at the same time as the current one.
▷ Delete all entries	Action	You can use this to delete all data logbook entries.
▶ Save logbooks		
File format	Selection <ul style="list-style-type: none"> ▪ CSV ▪ FDM 	Save the logbook in the preferred file format. You can then open the CSV file you saved on the PC in MS Excel, for example, and process it further ¹⁾ . You can import the FDM files into Fieldcare and archive them so they are tamper-proof.

DIAG/Logbooks		
Function	Options	Info
<ul style="list-style-type: none"> ▷ All data logbooks ▷ Data logbook SP1 ▷ Absorption data logbook ▷ Raw data logbook ▷ Data logbook 1 ... 8 ▷ All event logbooks ▷ Calibration logbook ▷ Diagnostic logbook ▷ Analyzer data logbook ▷ Analyzer event logbook ▷ Analyzer calibration logbook ▷ Configuration logbook ▷ HW version logbook ▷ Version logbook 	Action, commences as soon as the option is selected	<p>Use this function to save the logbook to an SD card.</p> <p>▶ Insert the SD card into the device card reader and select the logbook to be saved. Save the logbook in the preferred file format. You can then open the saved CSV file on a computer, such as in MS Excel, and make further edits there. You can import the FDM files into Fieldcare and archive them so they are tamper-proof.</p>
<p> The file name consists of Logbook ident (Menu/Setup/General settings/Logbooks), an abbreviation for the logbook and a time stamp.</p>		

- 1) CSV files use international number formats and separators. Therefore they must be imported into MS Excel as external data with the correct format settings. If you double-click the file to open it, the data are only displayed correctly if MS Excel is installed with the US country setting.

11.10 System information

DIAG/System information		
Function	Options	Info
Device tag	Read only	Individual device tag → General settings
Order code	Read only	You can order identical hardware with this code. This code changes on account of changes to the hardware and you can enter the new code you received from the manufacturer here ¹⁾ .
<p> To discover the version of your device, enter the order code into the search screen at the following address: www.products.endress.com/order-ident</p>		
Orig. order code ext.	Read only	Complete order code for the original device, resulting from the product structure.
Current order code ext.	Read only	Current code, taking into account changes to the hardware. You must enter this code yourself.
Serial number	Read only	The serial number allows you to access device data and documentation on the Internet: www.endress.com/device-viewer
Software version	Read only	Current version
Measuring parameter	Read only	Set measuring parameter
MPL version	Read only	Current version
▶ FXAB1 control module	Read only <ul style="list-style-type: none"> ▪ Firmware version ▪ Hardware version 	
▶ Photometer	Read only <ul style="list-style-type: none"> ▪ Firmware version ▪ Hardware version 	

DIAG/System information		
Function	Options	Info
▶ Sample preparation 1 ... 2	Read only <ul style="list-style-type: none"> ▪ SP type ▪ Order code ▪ Serial number ▪ Hardware version ▪ Software version ▪ Orig. order code ext. 	Depends on the type and number of sample preparations
▶ General information	Read only <ul style="list-style-type: none"> ▪ Current status ▪ SP type ▪ Order code ▪ Serial number ▪ Hardware version ▪ Software version ▪ Orig. order code ext. 	This information is provided for every electronics module available. Specify the serial numbers and order codes when servicing, for example.
▶ Modbus <i>Only with the Modbus option</i>	Read only <ul style="list-style-type: none"> ▪ Enable ▪ Bus address ▪ Termination ▪ Modbus TCP Port 502 	Modbus-specific information
▶ PROFIBUS <i>Only with the PROFIBUS option</i>	Read only <ul style="list-style-type: none"> ▪ Termination ▪ Bus address ▪ Ident number ▪ Baudrate ▪ DPVO state ▪ DPVO fault ▪ DPVO master addr ▪ DPVO WDT [ms] 	Module status and other PROFIBUS-specific information
▶ Ethernet <i>Only with the Ethernet, EtherNet/IP, Modbus TCP, Modbus RS485 or PROFIBUS DP option</i>	Read only <ul style="list-style-type: none"> ▪ Enable ▪ Webserver ▪ Link settings ▪ DHCP ▪ IP-Address ▪ Netmask ▪ Gateway ▪ Service switch ▪ MAC-Address ▪ EtherNetIP Port 44818 ▪ Modbus TCP Port 502 ▪ Webserver TCP Port 80 	Ethernet-specific information Display depends on the fieldbus protocol used.
▶ SD card	Read only <ul style="list-style-type: none"> ▪ Total ▪ Free memory 	
▶ System modules		
Backplane	Read only <ul style="list-style-type: none"> ▪ Description ▪ Serial number ▪ Order code ▪ Hardware version ▪ Software version 	This information is provided for every electronics module available. Specify the serial numbers and order codes when servicing, for example.
Base		
Display module		
Extension module 1 ... 8		
▶ Sensors	Read only <ul style="list-style-type: none"> ▪ Description ▪ Serial number ▪ Order code ▪ Hardware version ▪ Software version 	This information is provided for every sensor available. Specify the serial numbers and order codes when servicing, for example.

DIAG/System information		
Function	Options	Info
▶ Save system information		
▷ Save to SD card	File name assigned automatically (includes a time stamp)	The information is saved on the SD card in a "sysinfo" subfolder. The csv file can be read and edited in MS Excel for example. This file can be used when servicing the device.

1) Provided you give the manufacturer all the information about changes to the hardware.

11.11 Sensor information

▶ Select the channel you want from the list of channels.

Information in the following categories is displayed:

- **Extreme values**

Extreme conditions to which the sensor was previously exposed, e.g. min./max. temperatures²⁾

- **Operating time**

Operating time of the sensor under defined extreme conditions

- **Calibration information**

Calibration data of the last calibration

- **Sensor specifications**

Measuring range limits for main measured value and temperature

- **General information**

Information on sensor identification

The specific data that are displayed depends on what sensor is connected.

11.12 Simulation

You can simulate values at inputs and outputs for testing purposes:

- Current values at current outputs
- Measured values at inputs
- Relay contact opening or closing

 Only current values are simulated. Via the simulation function, it is not possible to calculate the totalized value for the flow or rainfall.

▶ Before simulation: enable the inputs and outputs in the Setup menu.

DIAG/Simulation		
Function	Options	Info
▶ Current output x:y		Simulation of an output current This menu appears once for each current output.
Simulation	Selection <ul style="list-style-type: none"> ▪ Off ▪ On Factory setting Off	If you simulate the value at the current output, this is indicated on the display by a simulation icon in front of the current value.
Current	2.4 to 23.0 mA Factory setting 4 mA	Set the desired simulation value.

2) Not available for all sensor types.

DIAG/Simulation		
Function	Options	Info
▶ Alarm relay ▶ Relay x.y		Simulation of a relay state This menu appears once for each relay.
Simulation	Selection ▪ Off ▪ On Factory setting Off	If you simulate the relay state, this is indicated on the display by a simulation icon in front of the relay display.
State	Selection ▪ Low ▪ High Factory setting Low	Set the desired state. The relay switches in accordance with your setting when you switch on the simulation. In the measured value display you see On (= Low) or Off (= High) for the simulated relay state.
▶ Meas. inputs		Simulation of a measured value (only for sensors)
Channel : parameter		This menu appears once for each measuring input.
Simulation	Selection ▪ Off ▪ On Factory setting Off	If you simulate the measured value, this is indicated on the display by a simulation icon in front of the measured value.
Main value	Depends on the sensor	Set the desired simulation value.
Sim. temperature	Selection ▪ Off ▪ On Factory setting Off	If you simulate the temperature measured value, this is indicated on the display by a simulation icon in front of the temperature.
Temperature	-50.0 to +250.0 °C (-58.0 to 482.0 °F) Factory setting 20.0 °C (68.0 °F)	Set the desired simulation value.

11.13 Device test

DIAG/Systemtest		
Function	Options	Info
▶ Analyzer		
▶ Sample collector		Is only displayed if a collecting vessel is provided.
▷ Empty sample collector		The sample collecting vessel can be automatically emptied in this menu.
▷ Start		
▷ Stop		
▶ Sample preparation 1 (CAT820/CAT860)		Depends on the connected sample preparation system
▶ Cabinet heating		Tests the housing heating
Cabinet temperature	Read only	Displays the current housing temperature
Mode	Read only	
▷ On for 10 minutes		The heating is switched on for 10 minutes.
▷ Off		The heating is switched off.

DIAG/Systemtest		
Function	Options	Info
▷ Automatic		The heating is automatically switched on and off in line with the housing temperature.
▶ Hose heating filter		Tests the hose heating (filter to pump)
Ambient temperature	Read only	Displays the current outside temperature
Mode	Read only	
▷ On for 10 minutes		The heating is switched on for 10 minutes.
▷ Off		The heating is switched off.
▷ Automatic		The heating is automatically switched on and off in line with the housing temperature.
▶ Hose heating analyzer		Tests the hose heating (pump to analyzer)
Ambient temperature	Read only	Displays the current outside temperature
Mode	Read only	
▷ On for 10 minutes		The heating is switched on for 10 minutes.
▷ Off		The heating is switched off.
▷ Automatic		The heating is automatically switched on and off in line with the housing temperature.
▷ Start sampling		The sample pump is switched on in interval mode in line with the settings under Menu/Setup/Sample preparation
▷ Start sampling, continuous mode		The sample pump is switched on in permanent mode.
▷ Stop sampling		The sample pump is switched off.
▶ Photometer		
Cleaning factor	Read only	
Raw value	Read only	
Temperature	Read only	
▶ Sample collector valve		This menu item is additionally displayed in the case of two-channel devices, two cascaded analyzers or if CAT860 sample preparation is connected. Test the valve for sample supply
▷ Towards sample collector		If CAT860 sample preparation is connected, this menu item is also displayed. The valve for sample supply is opened towards the collecting vessel.
▷ Towards outlet		If CAT860 sample preparation is connected, this menu item is also displayed. The valve for sample supply is opened towards the outlet.
Towards sample collector 1		This menu item is also displayed for two-channel devices. The valve for sample supply is opened towards collecting vessel 1.

DIAG/Systemtest		
Function	Options	Info
Towards sample collector 2		This menu item is also displayed for two-channel devices. The valve for sample supply is opened towards collecting vessel 2.
Towards analyzer 1		This menu item is also displayed for two cascaded analyzers. The valve for sample supply is opened towards analyzer 1.
Towards analyzer 2		This menu item is also displayed for two cascaded analyzers. The valve for sample supply is opened towards analyzer 2.
► Power Supply	Read only <ul style="list-style-type: none"> ▪ Digital Supply 1: 1.2V ▪ Digital Supply 2: 3.3V ▪ Analog Supply: 12.5V ▪ Sensor Supply: 24V ▪ Temperature 	Detailed list of power supply to instrument.  The actual values can vary without a malfunction being present.

11.14 Resetting

DIAG/Reset		
Function	Options	Info
▷ Device restart	Selection <ul style="list-style-type: none"> ▪ OK ▪ ESC 	Restart and keep all the settings
▷ Factory default	Selection <ul style="list-style-type: none"> ▪ OK ▪ ESC 	Restart with factory settings Settings that have not been saved are lost.

11.15 Operating time information

DIAG/Operating time information		
Function	Options	Info
► Operating time filter mats		
Filter mats	Read only	Displays the period of usage in days
► Operating time photometer		
Photometer	Read only	
► Remaining operating time		
► Liquid manager		Displays the remaining period of usage in days; i.e. the liquid manager can still be used for this many days.
Remaining operating time	Read only	
► Dispensers		Displays the remaining period of usage in days; i.e. the individual dispensers can still be used for this many days.
Remaining operating time	Read only	

DIAG/Operating time information		
Function	Options	Info
	Read only	
▶ Operating time sample preparation 1		In the case of two-channel devices, sample preparation 2 is also displayed
Device	Read only	
Filter	Read only	Displays the period of usage in days and hours
Operation < -20 °C	Read only	Displays the period of usage in days and hours
Operation > 50 °C	Read only	Displays the period of usage in days and hours
Membrane pump (CAT860)	Read only	Displays the period of usage in days and hours

Set the relevant counter reading to zero with "Reset".

11.16 Firmware history

Date	Version	Changes to firmware	Documentation
06/2017	01.06.04	Extension <ul style="list-style-type: none"> ▪ New mathematical function Formula ▪ Improvements <ul style="list-style-type: none"> - Chemical cleaning (CAT860) - Zero point calibration COD - Activation of the manual mode when the waste canister is full (COD) - Enhanced help text 	BA01245C/07/./03.16 BA01585C/07/./02.17 BA01240C/07/./04.17 BA01354C/07/./04.17 BA01575C/07/./03.17 BA01586C/07/./02.17 BA01574C/07/./03.17 BA01416C/07/./03.17 BA01435C/07/./03.17 BA01593C/07/./02.17
03/2016	01.06.00	Original software	BA01245C/07/./03.16

This product uses Lua, which is distributed under the following license:

Copyright © 1994–2013 Lua.org, PUC-Rio.

Permission is hereby granted, free of charge, to any person obtaining a copy of this software and associated documentation files (the "Software"), to deal in the Software without restriction, including without limitation the rights to use, copy, modify, merge, publish, distribute, sublicense, and/or sell copies of the Software, and to permit persons to whom the Software is furnished to do so, subject to the following conditions:

The above copyright notice and this permission notice shall be included in all copies or substantial portions of the Software.

THE SOFTWARE IS PROVIDED "AS IS", WITHOUT WARRANTY OF ANY KIND, EXPRESS OR IMPLIED, INCLUDING BUT NOT LIMITED TO THE WARRANTIES OF MERCHANTABILITY, FITNESS FOR A PARTICULAR PURPOSE AND NONINFRINGEMENT. IN NO EVENT SHALL THE AUTHORS OR COPYRIGHT HOLDERS BE LIABLE FOR ANY CLAIM, DAMAGES OR OTHER LIABILITY, WHETHER IN AN ACTION OF CONTRACT, TORT OR OTHERWISE, ARISING FROM, OUT OF OR IN CONNECTION WITH THE SOFTWARE OR THE USE OR OTHER DEALINGS IN THE SOFTWARE.

12 Maintenance

⚠ WARNING

Process pressure and temperature, contamination, electrical voltage

Risk of serious or fatal injury

- ▶ If the sensor has to be removed during maintenance work, avoid hazards posed by pressure, temperature and contamination.
- ▶ Make sure the device is de-energized before you open it.
- ▶ Power can be supplied to switching contacts from separate circuits. De-energize these circuits before working on the terminals.

NOTICE

Electrostatic discharge (ESD)

Risk of damaging the electronic components

- ▶ Take personal protective measures to avoid ESD, such as discharging beforehand at PE or permanent grounding with a wrist strap.
- ▶ For your own safety, only use genuine spare parts. With genuine parts, the function, accuracy and reliability are also ensured after maintenance work.

⚠ CAUTION

Automatic mode during calibration or maintenance work

Risk of injury from chemicals or contaminated media

- ▶ Before hoses are removed, make sure that no operation is currently running or about to start.
- ▶ Set the device to the manual mode.
- ▶ Wear protective clothing, goggles and gloves or take other suitable measures to protect yourself.

⚠ CAUTION

Failure to observe the maintenance intervals

Risk of personal injury and damage to property

- ▶ Keep to the recommended maintenance intervals

12.1 Maintenance schedule

Interval	Maintenance work
After every reagent replacement, during commissioning, maintenance and repair	Carry out zero point calibration
Every 3 months	(Depending on the application; as required) clean the (optional) sample collecting vessel
Every 3.2 months	Replace standard CY80FE (typically; with a calibration interval of 48 h)
Every 3.5 months	Replace reagent CY80FE (typically; with a measuring interval of 10 min, depending on the temperature and measuring range)
Every 6 months	<ul style="list-style-type: none"> ▪ Clean filter mats ▪ Replace dispensers
Every 12 months	<ul style="list-style-type: none"> ▪ (Where necessary) replace hoses: <ul style="list-style-type: none"> – Norprene, black – C-Flex, white ID 1.6 mm ▪ Replace filter mats ▪ Replace the O-ring in the cover of the sample collecting vessel
Every 2 to 3 years	(Where necessary) replace hoses: <ul style="list-style-type: none"> – C-Flex, white ID 3.2 mm – C-Flex, white ID 6.4 mm

Interval	Maintenance work
Every 4 years	Replace liquid manager
If required	<ul style="list-style-type: none"> ▪ Clean the housing ▪ Clean CAT8x0 sample preparation (automatic cleaning) ▪ Rinse system

12.2 Cleaning

⚠ CAUTION

Risk of injury from reagents escaping

- ▶ Clean the system every time before replacing consumables.

12.2.1 Clean the housing

i You can find an overview of the maintenance intervals here: →  133.

- ▶ Clean the front of the housing using commercially available cleaning agents only.

The front of the housing is resistant to the following in accordance with DIN 42 115:

- Ethanol (for a short time)
- Diluted acids (max. 2% HCl)
- Diluted bases (max. 3% NaOH)
- Soap-based household cleaning agents

NOTICE

Cleaning agents not permitted

Damage to the housing surface or housing seal

- ▶ Never use concentrated mineral acids or alkaline solutions for cleaning.
- ▶ Never use organic cleaners such as acetone, benzyl alcohol, methanol, methylene chloride, xylene or concentrated glycerol cleaner.
- ▶ Never use high-pressure steam for cleaning purposes.

12.2.2 Clean CAT8x0 sample preparation (automatic cleaning)

i You can find an overview of the maintenance intervals here: →  133.

The Liquiline System CAT8x0 for sample preparation facilitates regular backflushing of the filter and the sample hoses.

Select a suitable cleaning interval under **Menu/Setup/Sample preparation/Sample preparation 1** see "Sample preparation" section).

12.2.3 Rinse system

i You can find an overview of the maintenance intervals here: →  133.

i Measurement, cleaning or calibration is not possible while the bottles are removed.

Rinsing the collecting vessel with sample and draining it

1. Open the analyzer.
2. Stop the sample supply.
3. Press the soft key **MODE** and select **Manual mode**.
 - ↳ The display shows **Current mode- Manual**.
Wait until all operations have stopped. Ongoing operations can be stopped under **Menu/Operation/Manual operation**.

4. Select **Menu/Operation /Maintenance/Decommissioning/Sample collector/Empty sample collector/Start**

↳ The system is automatically rinsed with sample and emptied. This process takes approx. 4 minutes.

Rinsing the analyzer with water

Trigger the rinsing and draining of the collecting vessel before you rinse the analyzer
→  134.

1. Open all the reagent bottles and carefully remove the hoses. Open all the bottles if you wish to replace dispensers or hoses.
2. Dry the ends of the hoses with a clean paper towel.
3. Place the ends of the hoses into an empty beaker.
4. Once the operation has stopped, select **Menu/Operation/Maintenance/Decommissioning/Rinse with water**.
5. Immerse all the hoses (, RK, , S1, , P) in a beaker containing approx. 200 ml of distilled water in order to rinse the system with water.
6. Once again select **Menu/Operation /Maintenance/Decommissioning/Rinse with water**
7. Remove the hoses from the beaker and dry them with a clean paper towel.

12.2.4 Cleaning the (optional) sample collecting vessel

 You can find an overview of the maintenance intervals here: →  133.

Rinsing the collecting vessel with sample and draining it



1. Open the analyzer.
2. Stop the sample supply.
3. Press the soft key **MODE** and select **Manual mode**.
 - ↳ The display shows **Current mode- Manual**.
Wait until all operations have stopped. Ongoing operations can be stopped under **Menu/Operation/Manual operation**.
4. Select **Menu/Operation /Maintenance/Decommissioning/Sample collector/Empty sample collector/Start**
 - ↳ The system is automatically rinsed with sample and emptied. This process takes approx. 4 minutes.

Cleaning the collecting vessel

Trigger the rinsing and draining of the collecting vessel before you clean the collecting vessel →  135.



1. Remove all the hoses from the sample collecting vessel and the cable of the level monitoring system and take the sample collecting vessel out of the holder unit.
2. Open the sample collector by turning the cover in the clockwise direction.
3. Clean it with a small brush and plenty of water.
4. Return the collector to the holder unit and connect up all the hoses again correctly.
5. Start the sample preparation system.
6. Press the soft key **MODE** and select **Continue automatic mode** to start normal measurement.

12.3 Replacing reagents

 You can find an overview of the maintenance intervals here: →  133.

1. Open the analyzer.
2. Stop the sample supply.
3. Press the soft key **MODE** and select **Manual mode**.
 - ↳ The display shows **Current mode- Manual**.
Wait until all operations have stopped. Ongoing operations can be stopped under **Menu/Operation/Manual operation**.
4. Remove the bottles that you wish to replace by removing the hoses on the liquid manager. Use a paper towel to catch any reagents that may escape.
- 5.
6. Select **Menu/Operation /Maintenance/Bottle change mode/Bottle removal/Bottle selection**.
7. Select the bottles that you want to remove and confirm by selecting **OK**.
8. Select **Confirm bottles removed**.
9. Replace the bottles previously removed with fresh reagent
 - ↳ Reagents must be prepared according to the instructions for mixing a reagent.
10. Reconnect the hoses to the liquid manager.
11. Select **Menu/Operation /Maintenance/Bottle change mode/Bottle insertion/Bottle selection**.
12. Select all the bottles that you replaced and confirm by selecting **OK**.
13. Select **Confirm bottles inserted**.
14. If bottle level monitoring is enabled (**Menu/Setup/Analyzer/Extended setup/Diagnostics settings/Bottles**), it can be reset under **Menu/Operation/Maintenance/ Bottle change mode/Bottle insertion/Reset filling levels** .
15. The system must be calibrated after a replacement routine. Select **Menu/Operation/Manual operation/Determine calibration factor**.
16. After the calibration return to **MODE/Continue automatic mode** or **MODE/Start automatic mode** to start normal measurement.

12.4 Carry out zero point calibration



 You can find an overview of the maintenance intervals here: →  133.

1. Press the soft key **MODE** and select **Manual mode**.
 - ↳ The display shows **Current mode- Manual**.
Wait until all operations have stopped. Ongoing operations can be stopped under **Menu/Operation/Manual operation**.
2. Remove the bottles containing standard S1 by removing the hose from the bottle. Use a paper towel to catch any reagents that may escape. This prevents any contamination of the zero standard.
3. Replace the standard with zero standard.
4. Select **Menu/Operation /Maintenance/Bottle change mode/Bottle insertion/Bottle selection**.
5. Select **Standard S1** and confirm by pressing **OK**.
6. Select **Confirm bottles inserted**.
7. Go to **Menu/Operation/Manual operation** and select **Determine zero point**.

8. Perform a zero point calibration.
 - ↳ At a value > 0.02 mg/l Fe: Repeat the calibration until there is only a marginal difference (0.02 mg/l Fe) between the last two values.
9. Following successful calibration, you will be asked: "Do you want to accept the calibration data for adjustment?". To confirm, select **OK**
10. Remove the zero standard. Use either an additional hose in order to reconnect the standard calibration solution, or allow the hose to drain and dry the hose well.
11. Connect the standard calibration solution to the liquid manager.
12. Select **Menu/Operation /Maintenance/Bottle change mode/Bottle insertion/Bottle selection**.
13. Select **Standard S1** and confirm by pressing **OK**.
14. Select **Confirm bottles inserted**.

 It is advisable to then perform a manual calibration with the standard solution

12.5 Replacing the hoses

 You can find an overview of the maintenance intervals here: →  133.

You require the following parts:

NORPRENE hose, ID 1.6 mm	Part of the CAV800 maintenance kit
C-Flex hose, ID 3.2 mm	
Hose fitting	
1 pair of gloves that are resistant to the reagents used	



1. Rinse the system (see the "Rinsing the system" section)
 - ↳ There should not be any sample left in the sample collecting vessel.
2. Remove the bottles and the bottle tray.
3. Remove the cover of the carrier board.
4. Replace with hoses of the same diameter and length. Attach hose labels to the new hoses.
 - ↳ The drain hose D6 must be routed behind dispenser 7
5. Secure the cover and place the bottle tray back into the housing.
6. Connect the bottles to the appropriate covers and hoses.
7. Select **Menu/Operation /Maintenance/Bottle change mode/Bottle insertion/Bottle selection**.
8. Select all the bottles and press **OK**.
9. Select **Confirm bottles inserted**
10. Press the soft key **MODE** and select **Continue automatic mode** or **Start automatic mode**.

12.5.1 Replacing the pump hose (sample pump and pump, optional dilution module)

1. Open the analyzer.
2. Stop the sample supply.

3. Rinse the system (see the "Rinsing the system" section)
 - ↳ There should not be any sample left in the sample collecting vessel.
4. Remove the bottles and the bottle tray.
5. Press the soft key **MODE** and select **Manual mode**.
 - ↳ The display shows **Current mode- Manual**.
Wait until all operations have stopped. Ongoing operations can be stopped under **Menu/Operation/Manual operation**.
6. Open the bayonet lock of the peristaltic pump.
7. Replace the hose and, if necessary, replace the pump head.
8. Close the bayonet lock of the peristaltic pump.
9. Make sure all the hoses and connectors are seated correctly.
10. Secure the cover and place the bottle tray back into the housing.
11. Reset the operating hours counter of the pump hose at **Menu/Operation/Maintenance/Pump hose replacement/Reset operating time counter**.
12. After replacing the hose, go back to **MODE/Continue automatic mode** or **MODE/Start automatic mode** to start normal measurement.

12.6 Replace filter mats



 You can find an overview of the maintenance intervals here: →  133.

You require the following parts:

Filter mats (part of the CAV800 maintenance kit)

1. Open and remove the fan screen on the right and left underside of the analyzer.
2. Remove the used filter mats and replace them with new ones from the maintenance kit.
3. Reattach the fan screens.
4. Select **Menu/Operation/Operating time filter mats/Reset**

12.7 Replacing the dispensers

 You can find an overview of the maintenance intervals here: →  133.

You require the following parts:

NORPRENE hose, ID 1.6 mm	Part of the CAV800 maintenance kit
<ul style="list-style-type: none"> ▪ 10 ml dispensers with adapter ▪ 2.5 ml dispensers with adapter 	
1 pair of gloves that are resistant to the reagents used	

1. Rinse the system (see the "Rinsing the system" section).
2. Remove the bottles and the bottle tray.
3. Remove the cover of the carrier board.
4. Select **Menu/Operation/Dispenser replacement/Dispenser selection**.
5. Select the dispensers that you would like to replace.
6. Select **Draw up dispenser**.
7. Open the dispenser holder by pressing both snap-fit hooks together and removing it.

8. Turn the dispenser counterclockwise to remove it from the liquid manager.
9. Remove the adapter and the dispenser from the dispenser drive. To do so, hold the dispenser by the black block at the lower end and pull it from the metal pin.
10. Screw a new dispenser onto the liquid manager. Make sure that the dispenser is connected correctly.
11. Slide the dispenser holder over the snap-fit hooks. Ensure that the holder snaps into place. Make sure that the drain hose D6 is routed behind dispenser 7.
12. Secure the cover and place the bottle tray back into the housing.
13. Connect the bottles to the appropriate covers and hoses.
14. Select **Menu/Operation/Dispenser replacement/Dispenser selection**.
15. Select the dispensers that you replaced and click **OK**.
16. Select **Reset operating time counter**.
17. Select **Menu/Operation /Maintenance/Bottle change mode/Bottle insertion/Bottle selection**.
18. Select all the bottles and press **OK**.
19. Select **Confirm bottles inserted**
20. The system must be calibrated after a replacement routine. Select **Menu/Operation/Manual operation/Determine calibration factor**.
21. After the calibration return to **MODE/Continue automatic mode** or **MODE/Start automatic mode**.

12.8 Replace liquid manager

 You can find an overview of the maintenance intervals here: →  133.

You require the following parts:
CAV800-MMxx+PT for CA80FE

1. Rinse the system (see the "Rinsing the system" section).
2. Remove the bottles and the bottle tray.
3. Remove the cover of the carrier board.
4. Select **Menu/Operation/Dispenser replacement/Dispenser selection**.
5. Select all the dispensers.
6. Select **Draw up dispenser**.
7. Disconnect the power to the analyzer.
8. Open the dispenser holder by pressing both snap-fit hooks together and removing it.
9. Turn the dispenser clockwise to remove it from the liquid manager.
10. Remove the adapter and the dispenser from the dispenser drive. To do so, hold the dispenser by the black block at the lower end and pull it from the metal pin.
11. Open and remove the 4 Allen screws (4mm) on the liquid manager.
12. Disconnect the two plug-in connectors of the liquid manager from the main PCB.
13. Remove the four torx screws on the old liquid manager's stepping motor. Remove the old liquid manager's stepping motor.
14. Mount the stepping motor on the new liquid manager.
15. Install the new liquid manager in the reverse order.
16. Screw a new dispenser onto the liquid manager. Make sure that the dispenser is connected correctly.

17. Slide the dispenser holder over the snap-fit hooks. Ensure that the holder snaps into place. Make sure that the drain hose D6 is routed behind dispenser 7.
18. Secure the cover and place the bottle tray back into the housing.
19. Connect the bottles to the appropriate covers and hoses.
20. Switch the analyzer back on.
21. Select **Menu/Operation /Maintenance/Bottle change mode/Bottle insertion/Bottle selection**.
22. Select all the bottles and press **OK**.
23. Select **Confirm bottles inserted**
24. The system must be calibrated after a replacement routine. Select **Menu/Operation/Manual operation/Determine calibration factor**.
25. After the calibration return to **MODE/Continue automatic mode** or **MODE/Start automatic mode**.

12.9 Decommissioning

If the analyzer has not been in operation for more than 5 days, it must be decommissioned to avoid any damage to the device.

Proceed as follows to take the analyzer out of service:

1. Open the analyzer.
2. Stop the sample supply.
3. Press the soft key **MODE** and select **Manual mode**.
 - ↳ The display shows **Current mode- Manual**.
Wait until all operations have stopped. Ongoing operations can be stopped under **Menu/Operation/Manual operation**.
4. Select **Menu/Operation /Maintenance/Decommissioning/Sample collector/Empty sample collector/Start**
 - ↳ The system is automatically rinsed with sample and emptied. This process takes approx. 4 minutes.
5. In the case of a two-channel device, repeat the procedure for the second sample collecting vessel.
6. Open all the reagent bottles and carefully remove the hoses. Open all the bottles if you wish to replace dispensers or hoses.
7. Dry the ends of the hoses with a clean paper towel.
8. Place the ends of the hoses into an empty beaker.
9. Once the operation has stopped, select **Menu/Operation/Maintenance/Decommissioning/Rinse analyzer**.
10. Immerse all the hoses (RK, S1, P) in a beaker containing approx. 200 ml (6.76 fl.oz) of distilled water in order to rinse the system with water.
11. Once again select **Menu/Operation /Maintenance/Decommissioning/Sample collector/Empty sample collector/Start**
 - ↳ The system is automatically rinsed with sample and emptied. This process takes approx. 4 minutes.
12. Remove the hoses from the beaker and dry them with a clean paper towel.
13. Select **Menu/Operation/Maintenance/Decommissioning/Rinse analyzer** once again to rinse the hoses with air.
14. The analyzer can now be disconnected from the mains supply.

13 Repair

13.1 Spare parts

i Contact your Endress+Hauser Service Department if you have any questions about the spare parts.

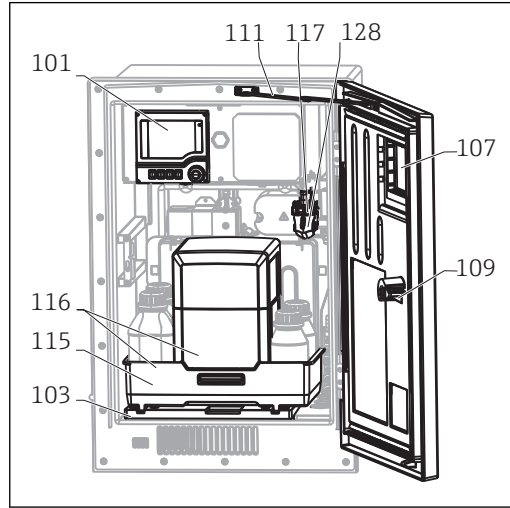

A0028752

73

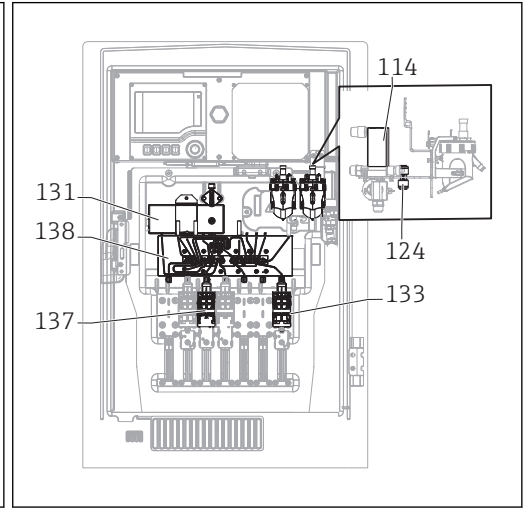

A0028753

74

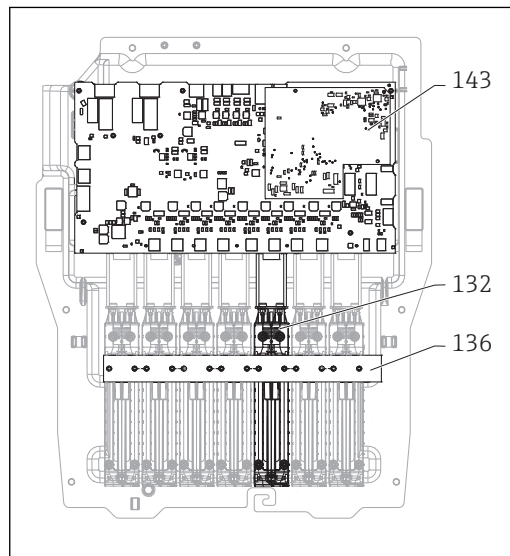

A0028754

75

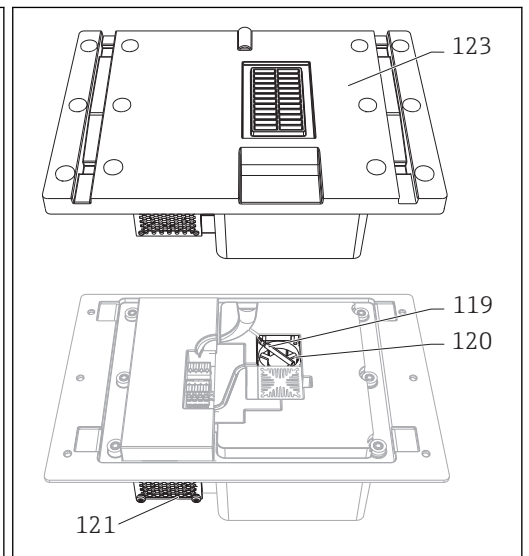

A0028755

76

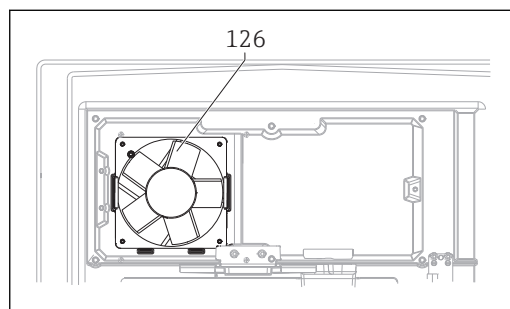

A0028756

77

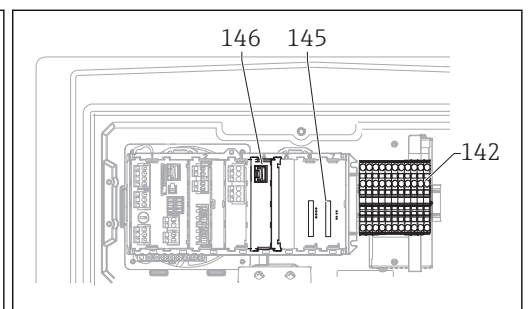

A0028757

78

Item No.	Description and contents	Order number Spare parts kit
101	Kit CA8x: controller with display Kit instructions, CA8x housing parts	71218395
102	Kit CA8x/CAT860: wall holder unit Kit instructions, CA8x housing parts	71218400
103	Kit CA8x/CAT860: base of the housing Kit instructions, CA8x housing parts	71218402
105	Kit CA8x: liquid detection (1 pc.) Kit instructions, CA80 collecting vessel	71218403
107	Kit CA8x: door with window Kit instructions, CA8x housing parts	71218409
108	Kit CA8x: M12 socket digit. sensor Kit instructions, CA8x electronic parts	71218419
109	Kit CA8x/CAT860: closing cylinder Kit instructions, CA8x housing parts	71218425
111	Kit CA8x/CAT860: door stop Kit instructions, CA8x housing parts	71218429
113	Kit CA8x: drain pipe Kit instructions, CA8x housing parts	71218431
114	Kit CA8x: valve Kit instructions, CA80 collecting vessel	71218433
115	Kit CA8x: bottle tray, no cooling Kit instructions, CA8x housing parts	71218434
117	Kit CA8x: collecting vessel, complete Kit instructions, CA80 collecting vessel	71218472
118	Kit CA8x: analyzer stand	71218473
122	Kit CA8x: hose fitting, straight, 4 mm Kit instructions: CA8x/CAT8xx hose connection	71229910
124	Kit CA8x: double hose conn. (10 pcs.) Kit instructions: CA8x/CAT8xx hose connection	71218484
126	Kit CA8x: housing fan, complete Kit instructions, CA8x electronic parts	71218486
127	Kit CA8x: carrier board cover Kit instructions, CA8x process engineering	71218487
128	Kit CA8x: collecting vessel, beaker (10 pcs.) Kit instructions, CA80 collecting vessel	71229918
131	Kit CA8x: photometer module (5 mm) Kit instructions, CA8x process engineering	71218488
132	Kit CA8x: linear drive (1 pc.) Kit instructions, CA8x process engineering	71218490
133	Kit CA8x: dispenser holder 10ml (10 pcs.) Kit instructions, CA8x process engineering	71222105
134	Kit CA8x: dispensers 10 ml (20 pcs.) Kit instructions, CA8x process engineering	71222106
135	Kit CA8x: dispensers 2.5 ml (20 pcs.) Kit instructions, CA8x process engineering	71222107
136	Kit CA8x: light barrier, linear drives Kit instructions, CA8x process engineering	71218491
137	Kit CA8x: dispenser holder 2.5ml (10 pcs.) Kit instructions, CA8x process engineering	71222108
138	Kit CA8x: liquid manager, complete (1 pc.) Kit instructions, CA8x process engineering	71218492

Item No.	Description and contents	Order number Spare parts kit
140	Kit CA8x: 10x Y-connector 6.4 x 6.4 x 6.4 Kit instructions: CA8x/CAT8xx hose connection	71229919
141	Kit CA8x: 10x Y-connector 3.2 x 3.2 x 3.2 Kit instructions: CA8x/CAT8xx hose connection	71229920
142	Kit CA8x: power unit 100-240 V AC Kit instructions, CA8x electronic parts	71218503
143	Kit CA8x: FXAB1 control module Kit instructions, CA8x electronic parts	71218504
144	Kit CA8x: DC/DC 24 V converter Kit instructions, CA8x electronic parts	71218505
145	Kit CA8x: backplane CM44 Kit instructions, CA8x electronic parts	71239304
146	Kit CA8x: interface module CM44 Kit instructions, CA8x electronic parts	71218507
149	Kit CA8x: 10x hose conn. PP 1.6 mm ID Kit instructions: CA8x/CAT8xx hose connection	71239300
150	Kit CA8x: 10x hose conn. PP 3.2 mm ID Kit instructions: CA8x/CAT8xx hose connection	71239302
151	Kit CA8x: basic module Base-E Kit instructions, CA8x electronic parts	71239305

Item No.	Description and contents	Order number Spare parts kit
No graphic	Hose, C-Flex ID 3.2 mm, sold by the meter	51504114
No graphic	C-Flex hose, ID 6.4 mm, material sold by the meter	51504115
No graphic	Hose NORPRENE A ID 1.6 mm, sold by the meter	51504116
No graphic	Safety bottle, black 1 l	51505802
No graphic	Safety bottle, colorless 1l	51505808
No graphic	Kit: buffer battery for backplane	71104102
No graphic	Kit: 1x terminal set	71107452
No graphic	Kit: 1x terminal set, module AOR	71107453
No graphic	Kit: 1x terminal set, module 4R	71155581
No graphic	Kit: 1x terminal set, module 4AO	71155582
No graphic	Kit: 1x terminal set, module 2x AI, 485	71155583
No graphic	Kit: 1x terminal set, module DIO	71219784
No graphic	Kit: display cable	71101762
No graphic	Kit, extension backplane module	71141366
No graphic	Kit CA8x: Liquid manager without motor	71299073
No graphic	Kit: Module ETH	71272410

13.2 Return

The product must be returned if repairs or a factory calibration are required, or if the wrong product was ordered or delivered. As an ISO-certified company and also due to legal regulations, Endress+Hauser is obliged to follow certain procedures when handling any returned products that have been in contact with medium.

To ensure swift, safe and professional device returns, please read the return procedures and conditions at www.endress.com/support/return-material.

13.3 Disposal

The device contains electronic components and must therefore be disposed of in accordance with regulations on the disposal of electronic waste.

Observe the local regulations.



Always dispose of batteries in accordance with local regulations on battery disposal.

CAUTION

Danger of injury if used reagents and reagent waste are disposed of incorrectly

- ▶ When disposing, follow the instructions of the safety data sheets for the chemicals used.
- ▶ Observe the local regulations regarding waste disposal.

14 Accessories

 The following are the most important accessories available at the time this documentation was issued. For accessories not listed here, please contact your service or sales office.

14.1 Sample preparation

Liquiline System CAT810

- Pressure pipe sampling + microfiltration
- Order according to product structure
(--> Online Configurator, www.endress.com/cat810)
- Technical Information TIO1138C/07/EN

Liquiline System CAT820

- Sampling + membrane filtration
- Order according to product structure
(--> Online Configurator, www.endress.com/cat820)
- Technical Information TIO1131C/07/EN

Liquiline System CAT860

- Pressure pipe sampling + membrane filtration
- Order according to product structure
(--> Online Configurator, www.endress.com/cat860)
- Technical Information TIO1137C/07/EN

 The Liquiline System CAT860 can only be operated with a Liquiline System CA80 single-channel device.

14.2 Consumables for CA80FE

14.2.1 Reagent set CY80FE

NOTICE

Reagents can be harmful to the environment

- ▶ Pay particular attention to the information provided in the safety data sheets concerning the disposal of reagents.

Ready-to-use reagent, 1 l (33.81 fl.oz.)

Order No. CY80FE-MM+SF

14.2.2 Standard solution CY80FE

1 l (34 fl.oz.) Standard solution with different concentrations of iron.

- 0 mg/l (ppm) Fe; Order No. CY80FE-MM+TG
- 0.1 mg/l (ppm) Fe; Order No. CY80FE-MM+TH
- 0.5 mg/l (ppm) Fe; Order No. CY80FE-MM+TK
- 2.0 mg/l (ppm) Fe; Order No. CY80FE-MM+TM
- 4.0 mg/l (ppm) Fe; Order No. CY80FE-MM+TO

14.3 Maintenance kit CAV800

Order according to product structure

Standard

- Dispensers, 2 x 2.5 ml and 4 x 10 ml, including mounted adapter
- Hoses
- Silicone grease, medium-viscosity, tube 2 g

- Blind plug
- Sealing caps
- Filter mats

Optional

- Inlet and outlet hoses
- Liquid manager without motor
- Collecting vessel, beaker (2 pcs.)

14.4 Cleaner CY820 (for hoses of sample preparation system and of sample collecting vessel)

Cleaning concentrates to clean the hoses of the sample preparation system and the sample collecting vessel

- Base cleaner, concentrate 1 l (33.81 fl.oz.), Order No. CY820-1+TA
- Acid cleaner, concentrate 1 l (33.81 fl.oz.), Order No. CY820-1+T1
- Oxidizing cleaning solution, concentrate 1 l (33.81 fl.oz.), Order No. CY820-1+UA

14.5 Upgrade kits CAZ800

Kit for upgrade with sample collecting vessel

- Sample collecting vessel with level monitoring, pre-fitted on mounting bracket
- Hoses, connection adapters
- Activation code
- Order No. CAZ800-MMA1

Kit for upgrade from one-channel device to two-channel device

- Valve for switching sample flow
- Two sample collecting vessels with level monitoring, pre-fitted on mounting bracket
- Hoses, connection adapters
- Activation code
- Order No. CAZ800-MMA2

Kit for upgrade for second, downstream analyzer

- Valve for switching sample flow
- Hoses, connection adapters
- Activation code
- Order No. CAZ800-MMM1

14.6 Sensors

14.6.1 pH glass electrodes

Orbisint CPS11D

- pH electrode for process technology
- Optional SIL version for connecting to SIL transmitter
- With dirt-repellent PTFE diaphragm
- Product Configurator on the product page: www.endress.com/cps11d



Technical Information TI00028C

Memosens CPS31D

- pH electrode with gel-filled reference system with ceramic diaphragm
- Product Configurator on the product page: www.endress.com/cps31d



Technical Information TI00030C

Ceramax CPS341D

- pH electrode with pH-sensitive enamel
- Meets highest demands of measuring accuracy, pressure, temperature, sterility and durability
- Product Configurator on the product page: www.endress.com/cps341d



Technical Information TI00468C

Ceragel CPS71D

- pH electrode with reference system including ion trap
- Product Configurator on the product page: www.endress.com/cps71d



Technical Information TI00245C

Orbipore CPS91D

- pH electrode with open aperture for media with high dirt load
- Product Configurator on the product page: www.endress.com/cps91d



Technical Information TI00375C

Orbipac CPF81D

- Compact pH sensor for installation or immersion operation
- In industrial water and wastewater
- Product Configurator on the product page: www.endress.com/cpf81d



Technical Information TI00191C

14.6.2 ORP electrodes

Orbisint CPS12D

- ORP sensor for process technology
- Product Configurator on the product page: www.endress.com/cps12d



Technical Information TI00367C

Ceraliquid CPS42D

- ORP electrode with ceramic junction and KCl liquid electrolyte
- Product Configurator on the product page: www.endress.com/cps42d



Technical Information TI00373C

Ceragel CPS72D

- ORP electrode with reference system including ion trap
- Product Configurator on the product page: www.endress.com/cps72d



Technical Information TI00374C

Orbipac CPF82D

- Compact ORP sensor for installation or immersion operation in process water and wastewater
- Product Configurator on the product page: www.endress.com/cpf82d



Technical Information TI00191C

Orbipore CPS92D

- ORP electrode with open aperture for media with high dirt load
- Product Configurator on the product page: www.endress.com/cps92d



Technical Information TI00435C

14.6.3 Conductivity sensors with inductive measurement of conductivity

Indumax CLS50D

- High-durability inductive conductivity sensor
- For standard and hazardous area applications
- With Memosens technology
- Product Configurator on the product page: www.endress.com/cls50d



Technical Information TI00182C

14.6.4 Conductivity sensors with conductive measurement of conductivity

Condumax CLS21D

- Two-electrode sensor in plug-in head version version
- Product Configurator on the product page: www.endress.com/CLS21d



Technical Information TI00085C

14.6.5 Oxygen sensors

Oxymax COS51D

- Amperometric sensor for dissolved oxygen
- With Memosens technology
- Product Configurator on the product page: www.endress.com/cos51d



Technical Information TI00413C

Oxymax COS61D

- Optical oxygen sensor for drinking water and industrial water measurement
- Measuring principle: quenching
- With Memosens technology
- Product Configurator on the product page: www.endress.com/cos61d



Technical Information TI00387C

Memosens COS81D

- Sterilizable, optical sensor for dissolved oxygen
- With Memosens technology
- Product Configurator on the product page: www.endress.com/cos81d



Technical Information TI01201C

14.6.6 Chlorine sensors

CCS142D

- Membrane-covered amperometric sensor for free chlorine
- Measuring range 0.01 to 20 mg/l
- With Memosens technology
- Product Configurator on the product page: www.endress.com/ccs142d



Technical Information TI00419C

14.6.7 Ion-selective sensors

ISEmax CAS40D

- Ion selective sensors
- Product Configurator on the product page: www.endress.com/cas40d

 Technical Information TI00491C

14.6.8 Turbidity sensors

Turbimax CUS51D

- For nephelometric measurements of turbidity and solids in wastewater
- 4-beam scattered light method
- With Memosens technology
- Product Configurator on the product page: www.endress.com/cus51d

 Technical Information TI00461C

Turbimax CUS52D

- Hygienic Memosens sensor for turbidity measurement in drinking water, process water and in utilities
- With Memosens technology
- Product Configurator on the product page: www.endress.com/cus52d

 Technical Information TI01136C

14.6.9 SAC and nitrate sensors

Viomax CAS51D

- SAC and nitrate measurement in drinking water and wastewater
- With Memosens technology
- Product Configurator on the product page: www.endress.com/cas51d

 Technical Information TI00459C

14.6.10 Interface measurement

Turbimax CUS71D

- Immersion sensor for interface measurement
- Ultrasonic interface sensor
- Product Configurator on the product page: www.endress.com/cus71d

 Technical Information TI00490C

14.7 Additional functionality

	Communication; software
51516983	Commubox FXA291 (hardware)
71127100	SD card with Liquiline firmware, 1 GB, industrial flash drive  You must quote the serial number of the device when ordering the activation code.
71135636	Activation code for Modbus RS485
71135637	Activation code for Modbus TCP
71219871	Activation code for EtherNet/IP
71279813	Activation code for Modbus TCP for module ETH

	Communication; software
71279830	Activation code for EtherNet/IP for module ETH
71211288	Activation code for feedforward control
71249548	Kit CA80: activation code for 1st digital sensor input
71249555	Kit CA80: activation code for 2nd digital sensor input

	Retrofit kits
71136999	Kit CSF48/CA80: retrofit service interface (CDI flange connector, counter nut)
71218507	KitCA80: interface module CM44
71111053	Kit CM442/CM444/CM448/CSF48/CA80: extension module AOR; 2 x relay, 2 x 0/4 to 20 mA analog output
71125375	Kit CM442/CM444/CM448/CSF48/CA80: extension module 2R; 2 x relay
71125376	Kit CM442/CM444/CM448/CSF48/CA80: extension module 4R; 4 x relay
71135632	Kit CM442/CM444/CM448/CSF48/CA80: extension module 2AO; 2 x 0/4 to 20 mA analog output
71135633	Kit CM442/CM444/CM448/CSF48/CA80: extension module 4AO; 4 x 0/4 to 20 mA analog output
71135631	Kit CM444/CM448/CSF48/CA80: extension module 2DS; 2 x digital sensor, Memosens
71135634	Kit CM442/CM444/CM448/CSF48/CA80: extension module 485; Ethernet configuration; can be extended to PROFIBUS DP or Modbus RS485 or Modbus TCP or EtherNet/IP. This requires an additional activation code, which can be ordered separately (see kit CM444/CM448/CSF48/CA80: extension module DIO; 2 x digital input; 2 x digital output; auxiliary power supply for digital output communication; software).
71135638	Kit CM444/CM448/CSF48/CA80: extension module DIO; 2 x digital input; 2 x digital output; auxiliary power supply for digital output
71135639	Kit CM442/CM444/CM448/CSF48/CA80: extension module 2AI; 2 x 0/4 to 20 mA analog input
71140889	Upgrade kit CM442/CM444/CM448/CSF48/CA80; extension module 485; Modbus RS485 (+ web server)
71140890	Upgrade kit CM442/CM444/CM448/CSF48/CA80; extension module 485; Modbus TCP (+ web server)
71219868	Upgrade kit CM442/CM444/CM448/CSF48/CA80; extension module 485; EtherNet/IP (+ web server)
71279809	Upgrade kit CM442/CM444/CM448/CSF48/CA80; extension module ETH + Modbus TCP
71279812	Upgrade kit CM442/CM444/CM448/CSF48/CA80; extension module ETH + EtherNet/IP
71141366	Kit CM442/CM444/CM448/CSF48/CA80: extension backplane

14.8 Measuring cable

CYK10 Memosens data cable

- For digital sensors with Memosens technology
- Product Configurator on the product page: www.endress.com/cyk10



Technical Information TI00118C

Memosens data cable CYK11

- Extension cable for digital sensors with Memosens protocol
- Product Configurator on the product page: www.endress.com/cyk11



Technical Information TI00118C

Measuring cable CYK81

- Terminated cable for extending sensor cables (e.g. Memosens, CUS31/CUS41)
- 2 x 2 cores, twisted with shielding and PVC sheath (2 x 2 x 0.5 mm² + shielding)
- Sold by meter, Order No.: 51502543

14.9 Software

Memobase Plus CYZ71D

- PC software to support laboratory calibration
- Visualization and documentation of sensor management
- Sensor calibrations saved in the database
- Order as per product structure, www.endress.com/cyz71d



Technical Information TI00502C

Field Data Manager Software MS20

- PC software for central data management
- Visualization of series of measurements and logbook events
- SQL database for secure data storage

14.10 Other accessories

14.10.1 SD card

- Industrial Flash Drive, 1 GB
- Weight: 2 g
- Order No. 71110815

14.10.2 Cable junction with Velcro strip

- 4 pieces, for sensor cable
- Order No. 71092051

15 Technical data

15.1 Input

Measured values	Fe [µg/l, mg/l, ppb, ppm]
Measuring range	CA80FE-AAM2: 0.05 to 2.5 mg/l (ppm) Fe CA80FE-AAM3: 0.1 to 5 mg/l (ppm) Fe
Types of input	<ul style="list-style-type: none"> ■ 1 or 2 measuring channels (analyzer main parameter) ■ 1 to 4 digital sensor inputs for sensors with Memosens protocol (optional) ■ Analog current inputs (optional)
Input signal	Depending on version 2 x 0/4 to 20 mA (optional), passive, potentially isolated
Current input, passive	<p>Span > 0 to 20 mA</p> <p>Signal characteristic Linear</p> <p>Internal resistance Non-linear</p> <p>Test voltage 500 V</p>
Hose specification (self-priming analyzer)	<ul style="list-style-type: none"> ■ Clearance: max. 1.0 m (3.3 ft) ■ Height: max. 0.5 m (1.6 ft) ■ Hose ID: 1.6 mm (1/16 inch)
Cable specification (for optional sensors with Memosens technology)	<p>Cable type Memosens data cable CYK10 or sensor fixed cable, each with cable end sleeves or M12 round-pin connector (optional)</p> <p>Cable length Max. 100 m (330 ft)</p>

15.2 Output

Output signal

Depending on version:

- 2 x 0/4 to 20 mA, active, potentially isolated (standard version)
- 4 x 0/4 to 20 mA, active, potentially isolated (version with "2 additional outputs")
- 6 x 0/4 to 20 mA, active, potentially isolated (version with "4 additional outputs")

Modbus RS485	
Signal encoding	EIA/TIA-485
Data transmission rate	2,400, 4,800, 9,600, 19,200, 38,400, 57,600 and 115,200 baud
Galvanic isolation	Yes
Bus termination	Internal slide switch with LED display

Ethernet and Modbus TCP	
Signal encoding	IEEE 802.3 (Ethernet)
Data transmission rate	10 / 100 MBd
Galvanic isolation	Yes
Connection	RJ45, M12 optional
IP address	DHCP or configuration using menu

EtherNet/IP	
Signal encoding	IEEE 802.3 (Ethernet)
Data transmission rate	10 / 100 MBd
Galvanic isolation	Yes
Connection	RJ45, M12 optional (D-encoded)
IP address	DHCP (default) or configuration via menu

Signal on alarm

Adjustable, as per NAMUR Recommendation NE 43

- In measuring range 0 to 20 mA:
Error current from 0 to 23 mA
- In measuring range 4 to 20 mA:
Error current from 2.4 to 23 mA
- Factory setting for error current for both measuring ranges:
21.5 mA

Load

Max. 500 Ω

Transmission behavior

Linear

15.3 Current outputs, active

Span 0 to 23 mA

Signal characteristic Linear

Electrical specification
Output voltage
 Max. 24 V
Test voltage
 500 V

Cable specification
Cable type
 Recommended: shielded cable
Cable specification
 Max. 2.5 mm² (14 AWG)

15.4 Relay outputs

Electrical specification
Relay types

- 1 single-pin changeover contact (alarm relay)
- 2 or 4 single-pin changeover contacts (optional with extension modules)

Maximum load

- Alarm relay: 0.5 A
- All other relays: 2.0 A

Relay switching capacity

Base module (Alarm relay)

Switching voltage	Load (max.)	Switching cycles (min.)
230 V AC, cosΦ = 0.8 to 1	0.1 A	700,000
	0.5 A	450,000
115 V AC, cosΦ = 0.8 to 1	0.1 A	1,000,000
	0.5 A	650,000
24 V DC, L/R = 0 to 1 ms	0.1 A	500,000
	0.5 A	350,000

Extension module

Switching voltage	Load (max.)	Switching cycles (min.)
230 V AC, $\cos\Phi = 0.8$ to 1	0.1 A	700,000
	0.5 A	450,000
	2 A	120,000
115 V AC, $\cos\Phi = 0.8$ to 1	0.1 A	1,000,000
	0.5 A	650,000
	2 A	170,000
24 V DC, L/R = 0 to 1 ms	0.1 A	500,000
	0.5 A	350,000
	2 A	150,000

Minimum load (typical)

- Min. 100 mA at 5 V DC
- Min. 1 mA at 24 V DC
- Min. 5 mA at 24 V AC
- Min. 1 mA at 230 V AC

15.5 Protocol-specific data

Modbus RS485	Protocol	RTU/ASCII
	Function codes	03, 04, 06, 08, 16, 23
	Broadcast support for function codes	06, 16, 23
	Output data	16 measured values (value, unit, status), 8 digital values (value, status)
	Input data	4 setpoints (value, unit, status), 8 digital values (value, status), diagnostic information
	Supported features	Address can be configured using switch or software

Modbus TCP	TCP port	502
	TCP connections	3
	Protocol	TCP
	Function codes	03, 04, 06, 08, 16, 23
	Broadcast support for function codes	06, 16, 23
	Output data	16 measured values (value, unit, status), 8 digital values (value, status)
	Input data	4 setpoints (value, unit, status), 8 digital values (value, status), diagnostic information
	Supported features	Address can be configured using DHCP or software

Web server

The Web server enables full access to the device configuration, measured values, diagnostic messages, logbooks and service data via standard WiFi/WLAN/LAN/GSM or 3G routers with a user-defined IP address.

TCP port	80
Supported features	<ul style="list-style-type: none"> ▪ Remote-controlled device configuration(1 session) ▪ Save/restore device configuration (via SD card) ▪ Logbook export (file formats: CSV, FDM) ▪ Access to Web server via DTM or Internet Explorer ▪ Login ▪ Web server can be switched off

EtherNet/IP

Log	EtherNet/IP	
ODVA certification	Yes	
Device profile	Generic device (product type: 0x2B)	
Manufacturer ID	0x049E _h	
Device type ID	0x109F	
Polarity	Auto-MIDI-X	
Connections	CIP	12
	I/O	6
	Explicit message	6
	Multicast	3 consumers
Minimum RPI	100 ms (default)	
Maximum RPI	10000 ms	
System integration	EtherNet/IP	EDS
	Rockwell	Add-on-Profile Level 3, Faceplate for Factory Talk SE
IO data	Input (T → O)	Device status and diagnostic message with highest priority Measured values: <ul style="list-style-type: none"> ▪ 16 AI (analog input) + Status + Unit ▪ 8 DI (discrete input) + Status
	Output (O → T)	Actuating values: <ul style="list-style-type: none"> ▪ 4 AO (analog output) + status + unit ▪ 8 DO (discrete output) + Status

15.6 Power supply

Supply voltage

 The analyzer is fitted with a power cable and a safety plug with a cable length of 4.3 m (14.1 ft).

Analyzers with order specification CA80xx-CA (CSA C/US General Purpose) are fitted with a power cable that meets the North American standard.

- 100 to 120 V AC / 200 to 240 V AC
or 24 V DC
- 50 or 60 Hz

NOTICE

The device does not have a power switch

- ▶ The customer must provide a protected circuit breaker in the vicinity of the device.
- ▶ The circuit breaker must be a switch or power switch, and you must label it as the circuit breaker for the device.
- ▶ At the supply point, the power supply for the 24 V versions must be isolated from dangerous live cables by double or reinforced insulation.

Fieldbus connection

Supply voltage: not applicable

Power consumption

130 VA + 660 VA per hose heater, max. 1450 VA

Fuse

5 x 20 mm 10 A/250 V fine-wire fuse for hose trace heating system

Cable entries

- 4 x bores for M16, G3/8, NPT3/8", Memosens connection
- 4 x bores for M20, G1/2, NPT1/2"

Hose entries

4 x bores for M32 for sample inflow and outflow

Cable specification

Cable gland	Permitted cable diameter
M16x1.5 mm	4 to 8 mm (0.16 to 0.32")
M12x1.5 mm	2 to 5 mm (0.08 to 0.20")
M20x1.5 mm	6 to 12 mm (0.24 to 0.48")
NPT3/8"	4 to 8 mm (0.16 to 0.32")
G3/8	4 to 8 mm (0.16 to 0.32")
NPT1/2"	6 to 12 mm (0.24 to 0.48")
G1/2	7 to 12 mm (0.28 to 0.48")

 Cable glands mounted at the factory are tightened with 2 Nm.

Connecting optional modules

NOTICE

Unacceptable hardware combinations (due to conflicts in power supply)

Incorrect measurements or total failure of the measuring point as a result of heat build-up or overloading

- ▶ Find out if the planned extension for your controller results in a permitted hardware combination (Configurator on www.endress.com/CA80FE).
- ▶ Remember that the sum of all current inputs and outputs may not exceed 8.
- ▶ Make sure not to use more than two "DIO" modules. More "DIO" modules are not permitted.
- ▶ Please contact your Endress+Hauser sales center should you have any questions.

Overview of all the modules available

Module name				
AOR	2R	4R	2DS	DIO
<ul style="list-style-type: none"> ■ 2 x 0/4 to 20mA analog outputs ■ 2 relays ■ Order No. 71111053 	<ul style="list-style-type: none"> ■ 2 relays ■ Order No. 71125375 	<ul style="list-style-type: none"> ■ 4 relays ■ Order No. 71125376 	<ul style="list-style-type: none"> ■ 2 digital sensor inputs ■ 2 power supply systems for digital sensors ■ Order No. 71135631 	<ul style="list-style-type: none"> ■ 2 digital inputs ■ 2 digital outputs with auxiliary voltage ■ Order No. 71135638

Module name				
2AO	4AO	2AI	485	ETH
<ul style="list-style-type: none"> 2 x 0/4 to 20mA analog outputs Order No. 71135632 	<ul style="list-style-type: none"> 4 x 0/4 to 20mA analog outputs Order No. 71135633 	<ul style="list-style-type: none"> 2 x 0/4 to 20mA analog inputs Order No. 71135639 	<ul style="list-style-type: none"> Ethernet (web server or Modbus TCP) Order No. 71135634 	<ul style="list-style-type: none"> Web server and Ethernet/IP or Modbus TCP Order No. 71272410

i PROFIBUS DP (module 485)

Contacts 95, 96 and 99 are jumpered in the connector. This ensures that PROFIBUS communication is not interrupted if the connector is disconnected.

Sensor connection
(optional)

Sensors with Memosens protocol

Sensor types	Sensor cable	Sensors
Digital sensors without additional internal power supply	With plug-in connection and inductive signal transmission	<ul style="list-style-type: none"> ▪ pH sensors ▪ ORP sensors ▪ Combined sensors ▪ Oxygen sensors (amperometric and optical) ▪ Conductivity sensors with conductive measurement of conductivity ▪ Chlorine sensors (disinfection)
	Fixed cable	Conductivity sensors with inductive measurement of conductivity
Digital sensors with additional internal power supply	Fixed cable	<ul style="list-style-type: none"> ▪ Turbidity sensors ▪ Sensors for interface measurement ▪ Sensors for measuring the spectral absorption coefficient (SAC) ▪ Nitrate sensors ▪ Optical oxygen sensors ▪ Ion-sensitive sensors

15.7 Performance characteristics

Measured error ³⁾	CA80FE-AAM2: 0.05 to 2.5 mg/l (ppm) Fe CA80FE-AAM3: 0.1 to 5 mg/l (ppm) Fe	±0.04 mg/l (ppm) ±0.1 mg/l (ppm)
Measured error for sensor inputs	→ Documentation of the connected sensor	
Measured error for current inputs and outputs	Typical measured errors: < 20 µA (with current values < 4 mA) < 50 µA (with current values 4 to 20 mA) at 25 °C (77° F) in each case Additional measured error depending on the temperature: < 1.5 µA/K	
Repeatability ⁴⁾	<ul style="list-style-type: none"> ■ < 0.25 mg/l (ppm): ± 0.02 mg/l (ppm) Fe ■ 0.25 to 0.50 mg/l (ppm): ± 0.03 mg/l (ppm) Fe ■ > 0.50 mg/l (ppm): ± 0.06 mg/l (ppm) Fe 	
Repeatability of sensor inputs	→ Documentation of the connected sensor	
Measuring interval	Continuous (approx. 5 min), adjustable 10 min to 24 h	
Sample requirement	22 ml/measurement	
Reagent requirement	<ul style="list-style-type: none"> ■ Approx. 65 µl per measurement ■ 280 ml reagent per month, the reagent will last for approx. 3.5 months given a measuring interval of 10 min 	
Standard requirements	given a calibration interval of 48 h approx. 310 ml (10.48 fl.oz) per month	
Calibration interval	1 h to 90 days, depending on the application and ambient conditions	
Maintenance interval	Every 3 to 6 months, depending on the application	
Maintenance effort	<ul style="list-style-type: none"> ■ Weekly: visual inspection ■ Quarterly: 1 hour 	

3) According to ISO 15839 with standard solutions. Measured errors include all the uncertainties of the analyzer. They do not include the uncertainties from the standard solutions used as a reference.

4) According to ISO 15839 with standard solutions. Measured errors include all the uncertainties of the analyzer. They do not include the uncertainties from the standard solutions used as a reference.

15.8 Environment

Ambient temperature range	+5 to +40 °C (41 to 104 °F)
Storage temperature	-20 to +60 °C (-4 to 140 °F)
Humidity	10 to 95 %, non-condensating
Degree of protection	IP55 (cabinet, analyzer stand), TYPE 3R (cabinet, analyzer stand)
Electromagnetic compatibility	Interference emission and interference immunity as per EN 61326-1:2013, Class A for Industry
Electrical safety	According to EN/IEC 61010-1:2010, Class I equipment Low voltage: overvoltage category II For installations up to 2000 m (6500 ft) above MSL
Degree of contamination	The product is suitable for pollution degree 2.

15.9 Process

Sample temperature	4 to 40 °C (39 to 104 °F)
Consistency of the sample	Low solids content (turbidity < 50 NTU), aqueous, homogenized
Sample supply	Unpressurized

15.10 Mechanical construction

Dimensions

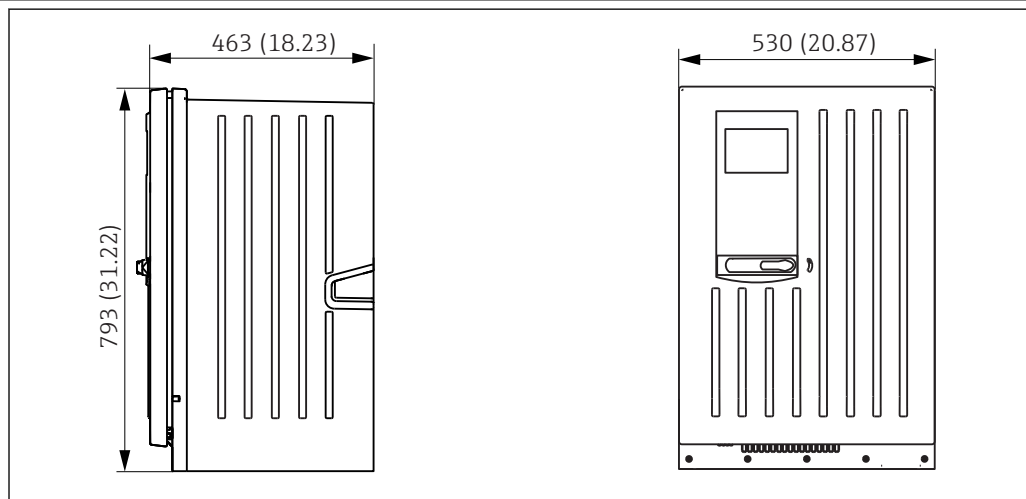

79 Liquiline System CA80 closed version, dimensions in mm (in)

A0028820

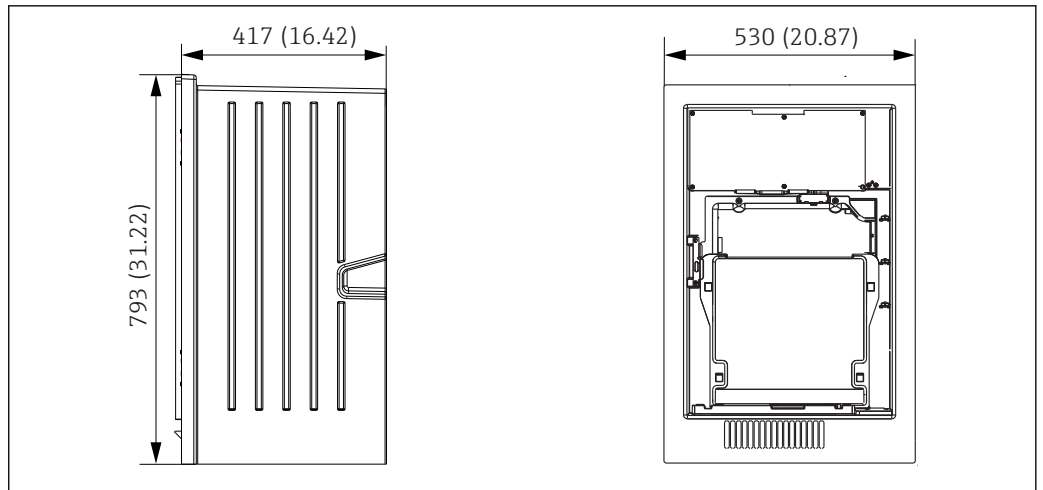

80 Liquiline System CA80 open version, dimensions in mm (in)

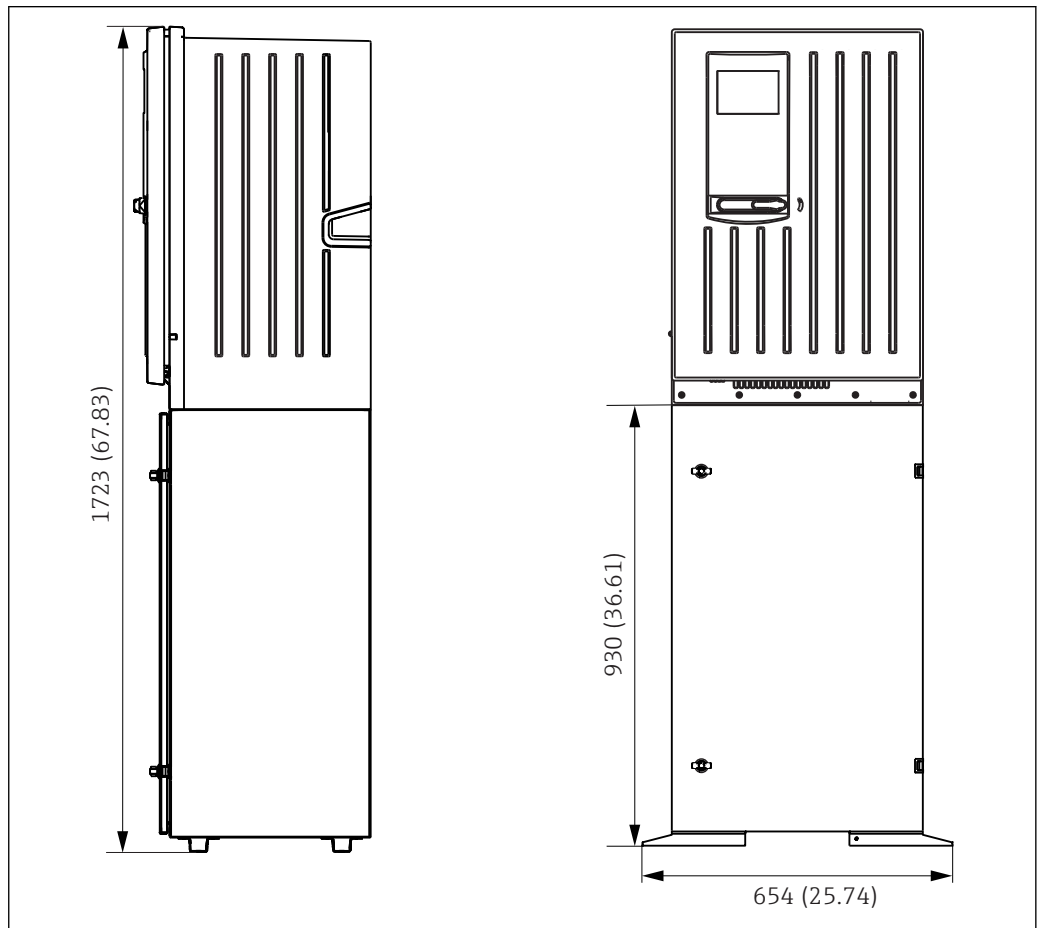

81 Liquiline System CA80 with base, dimensions in mm (in)

Weight

Order version

- Cabinet version
- Open installation
- Analyzer stand

Weight

- 39.5 kg (87.1 lbs)
- 31.5 kg (69.45 lbs)
- 72.5 kg (159.8 lbs)

Materials

Parts not in contact with medium	
Cabinet version, exterior cover	Plastic ASA+PC
Open installation, exterior cover	
Cabinet version, interior lining	Plastic PP
Open installation, interior lining	
Window	Shatterproof glass, coated
Reagent container	Plastic PP
Insulation	Plastic EPP (extruded PP)
Base, analyzer stand	Powder-coated sheet steel

Parts in contact with medium	
Dispensers	Plastic PP and elastomer TPE
Liquid manager	Plastic PP and elastomer FKM
Hoses	C-Flex, NORPRENE
Optical window	Glass
Molded seal	Elastomer FFKM
Drain pipe	Plastic PP
Sample collecting vessel (optional) <ul style="list-style-type: none"> ■ Beaker ■ Cover ■ Level detector pins ■ Seal 	<ul style="list-style-type: none"> ■ Plastic PMMA ■ Plastic PP ■ Stainless steel 1.4404 (V4A) ■ EPDM
Valve (optional)	PVDF

Index

A

Activation code	60
Adapting the diagnostic behavior	112
Additional functions	
Cleaning programs	99
Controller	92
Limit contactors	87
Mathematical functions	102
Advanced setup	55
Alarm relay	82
Ambient temperature range	162
Assignment	
Port assignment	14
Slot assignment	14

B

Base mounting	22
Basic settings	49
Basic setup	48
Bus termination	35

C

Cable entries	157
Cable specification	157
optional sensors with Memosens technology	152
Calculated pH value	106
Change password	61
Check	
Connection	37
Installation	22
Installation and function	47
Chemoclean	33, 100
Chemoclean Plus	101
Chlorine regulation with feedforward control	71
Cleaning cycle	102
Cleaning function	85
Cleaning programs	
Chemoclean	100
Chemoclean Plus	101
Manual cleaning	102
Standard cleaning	100
Cleaning unit	33
Commissioning	45
Starting	48
Configuration	
Binary inputs	76
Binary outputs	77
Configure	
Actions	43
Free text	44
Numerical values	43
Operating language	48
Picklists	43
Tables	44
Connection	
Analyzer	23

Cable entries	157
Check	37
Fieldbus	33
Hose entries	157
Optional module	30
Sensors	29
Supply voltage	157
Web server	38, 39
Controller	83, 92
Controller structure	92
Current input	
passive	152
Current inputs	69
Current outputs	79
active	154

D

Data management	59
Date	49
Declaration of Conformity	17
Degassed conductivity	104
Degree of contamination	162
Degree of protection	162
Description	
Device	10
Design	
Device	10
Designated use	7
Device description	10
Device design	10
Device variables	86
Device-specific diagnostic messages	114
Device-specific errors	110
Diagnostic messages	
Adapting	112
Classification	112
Device-specific	114
Fieldbus	111
Onsite display	111
Outputting via the relay	84
Sensor-specific	120
Web browser	111
Diagnostics list	121
Dimensions	18, 162
Disposal	144
Documentation	6
Dual conductivity	105

E

Electrical safety	162
Electromagnetic compatibility	162
Ensuring the degree of protection	36
Equipment architecture	14
EtherNet/IP	40, 58, 87, 156
Event logbook	121
Exporting the setup	60

F

Fieldbus	
Connection	33
Termination	35
Firmware history	132
Firmware update	59
Formula	106
Function check	47
Fuse	157

H

Hardware settings	35
Hold settings	50
Hose entries	157
Hose specification	152
Humidity	162

I

Incoming acceptance	16
Input	
Measured values	152
Input signal	152
Inputs	
Binary	70
Current inputs	69
Installation	
Check	22
Installation conditions	18

L

Laplace representation	92
Limit contactors	82, 87
Loading the setup	59
Logbooks	50, 122

M

Maintenance	133
Manipulated variable	83
Materials	164
Mathematical functions	102
Calculated pH value	106
Degassed conductivity	104
Difference	103
Dual conductivity	105
Formula	106
Redundancy	103
rH value	104
Measured values	152
Measuring range	152
Measuring system	10
Modbus	40, 56, 86
Modbus RS485	155
Modbus TCP	155

N

Nameplate	16
-----------	----

O

Occupational safety	7
Operating language	48

Operating time information	131
Operation	
Configure	43
General settings	49
Operational safety	7
Output	
Output signal	153
Relay outputs	154
Outputs	
Binary	70
Current outputs	79
EtherNet/IP	87
Modbus	86
PROFIBUS DP	86
Relay	82

P

Port assignment	14
Post-installation check	47
Power consumption	157
Power supply	157
Cable entries	157
Cable specification	157
Connecting digital communication	33
Connecting optional modules	30
Connecting the analyzer	23
Fuse	157
Hose entries	157
Power consumption	157
Sensor connection	29
Supply voltage	157
Power up	48
Process errors without messages	110
Product safety	9
PROFIBUS DP	40, 56
Device variables	86
PROFIBUS variables	86
PROFIBUS variables	86
Protocol-specific data	155

R

Relay	82
Repair	141
Requirements for the personnel	7
Reset	131
Return	143
rH value	104

S

Safety	
IT	9
Occupational safety	7
Operation	7
Product	9
Safety instructions	7
Saving the setup	59
Scope of delivery	17
Sensor	
Connection	29

Sensor information	128
Sensor-specific diagnostic messages	120
Service interface	39
Settings	
Advanced	55
Diagnostics	55
EtherNet/IP	58
General	49
Hardware	35
Modbus	56
PROFIBUS DP	56
Web server	57
Setup	
Basic	48
Simulation	128
Slot assignment	14
Spare parts	141
Standard cleaning	100
State of the art	9
Storage temperature	162
Supply voltage	157
Symbols	5
System information	126
System integration	
Fieldbus	40
Service interface	39
Web server	38
Systemtest	129
T	
Technical data	
Environment	162
Input	152
Mechanical construction	162
Output	153
Process	162
Protocol-specific data	155
Relay outputs	154
Technical personnel	7
Terminal diagram	15
Time	49
Troubleshooting	110
Diagnostic information	111
General troubleshooting	110
Types of cleaning	100
Types of input	152
U	
Use	
Designated	7
W	
Wall mounting	20
Warnings	5
Web server	57, 156
Weight	163

www.addresses.endress.com
