

Technical Information

Cerabar PMP23

Process pressure measurement



Pressure transducer with hygienic, flush-mounted metal sensors

Application

The Cerabar is a pressure transducer for the measurement of absolute and gauge pressure in gases, vapors, liquids and dust for applications with hygienic requirements. The Cerabar can be used internationally thanks to a wide range of approvals and process connections.

Your benefits

- High reproducibility and long-term stability
- Reference accuracy: up to 0.3%
- Customized measuring ranges
 - Turn down up to 5:1
 - Sensor for measuring ranges up to 40 bar (600 psi)
- Housing and process isolating diaphragm made of 316L
- IP69 protection
- Fully-welded process connections
- Suitable for CIP/SIP cleaning

Table of contents





Document information	3	Environment	17
Document function	3	Ambient temperature range	17
Symbols used	3	Storage temperature range	17
Documentation	4	Climate class	17
Terms and abbreviations	5	Degree of protection	17
Turn down calculation	6	Vibration resistance	17
		Electromagnetic compatibility	17
Function and system design	7	Process	18
Measuring principle - process pressure measurement	7	Process temperature range for devices with metallic process isolating diaphragm	18
Measuring system	7	Pressure specifications	18
Device features	8	Mechanical construction	19
Product design	8	Design, dimensions	19
System integration	9	Electrical connection	19
		Housing	20
Input	10	Process connections with flush-mounted, metal process isolating diaphragm	21
Measured variable	10	Materials in contact with process	26
Measuring range	10	Materials not in contact with process	27
		Cleaning	27
Output	11	Operability	28
Output signal	11	Plug-on display PHX20 (optional)	28
Signal range 4 to 20 mA	11	Certificates and approvals	29
Load (for 4 to 20 mA devices)	11	CE mark	29
Load resistance (for 0 to 10 V devices)	11	RCM-Tick marking	29
Signal on alarm 4 to 20 mA	11	EAC conformity	29
Dead time, time constant	11	Approval	29
Dynamic behavior	12	Safety Instructions (XA)	29
		Suitability for hygienic processes	29
Power supply	13	Pressure Equipment Directive 2014/68/EU (PED)	30
Terminal assignment	13	Manufacturer declarations	30
Supply voltage	13	Other standards and guidelines	31
Current consumption and alarm signal	13	CRN approval	31
Power supply fault	13	Calibration unit	32
Electrical connection	13	Calibration	32
Cable specification	14	Inspection certificates	32
Residual ripple	14	Additional approval	32
Influence of power supply	14	Ordering information	32
Overvoltage protection	14	Scope of delivery	32
		Accessories	33
Performance characteristics of metallic process isolating diaphragm	15	Weld-in adapter	33
Reference operating conditions	15	Process adapter M24	33
Measuring uncertainty for small absolute pressure measuring ranges	15	Plug-on display PHX20	33
Influence of the installation position	15	M12 plug connectors	34
Resolution	15	Documentation	35
Reference accuracy	15	Field of Activities	35
Thermal change of the zero output and the output span	15	Technical Information	35
Long-term stability	15	Operating Instructions	35
Switch-on time	15	Brief Operating Instructions	35
		Safety Instructions (XA)	35
Installation	16		
Installation conditions	16		
Influence of the installation position	16		
Mounting location	16		

Document information



Document function The document contains all the technical data on the device and provides an overview of the accessories and other products that can be ordered for the device.

Symbols used







Safety symbols

Symbol	Meaning
	DANGER! This symbol alerts you to a dangerous situation. Failure to avoid this situation will result in serious or fatal injury.
	WARNING! This symbol alerts you to a dangerous situation. Failure to avoid this situation can result in serious or fatal injury.
	CAUTION! This symbol alerts you to a dangerous situation. Failure to avoid this situation can result in minor or medium injury.
	NOTE! This symbol contains information on procedures and other facts which do not result in personal injury.

Electrical symbols

Symbol	Meaning	Symbol	Meaning
	Protective ground connection A terminal which must be connected to ground prior to establishing any other connections.		Ground connection A grounded terminal which, as far as the operator is concerned, is grounded via a grounding system.

Symbols for certain types of information

Symbol	Meaning
	Permitted Procedures, processes or actions that are permitted.
	Forbidden Procedures, processes or actions that are forbidden.
	Tip Indicates additional information.
	Reference to documentation
	Reference to page
	Reference to graphic
	Visual inspection

Symbols in graphics

Symbol	Meaning
1, 2, 3 ...	Item numbers
	Series of steps
A, B, C, ...	Views

Documentation

 The document types listed are available:
In the Download Area of the Endress+Hauser Internet site: www.endress.com → Download

Brief Operating Instructions (KA): getting the 1st measured value quickly

The Brief Operating Instructions contain all the essential information from incoming acceptance to initial commissioning.

Operating Instructions (BA): your comprehensive reference

These Operating Instructions contain all the information that is required in various phases of the life cycle of the device: from product identification, incoming acceptance and storage, to mounting, connection, operation and commissioning through to troubleshooting, maintenance and disposal.

Safety Instructions (XA)

Safety Instructions (XA) are supplied with the device depending on the approval. These instructions are an integral part of the Operating Instructions.

Device	Directive	Documentation	Option ¹⁾
PMP23	ATEX II 1/2G Ex ia IIC T4 Ga/Gb	XA01271P	BA
PMP23	FM IS Cl. I, Div.1 Gr. A-D T4	XA01321P	FA
PMP23	CSA C/US IS Cl. I Div. 1 Gr. A-D	XA01322P	CB
PMP23	EAC Ex ia IIC T4 Ga/Gb	XA01540P	GA
PMP23	IEC Ex ia IIC T4 Ga/Gb	XA01271P	IA
PMP23	NEPSI Ex ia IIC T4	XA01363P	NA
PMP23	TIIS Ex ia IIC T4	In preparation	TA

1) Product Configurator, order code for "Approval"

 The nameplate provides information on the Safety Instructions (XA) that are relevant for the device.

Terms and abbreviations

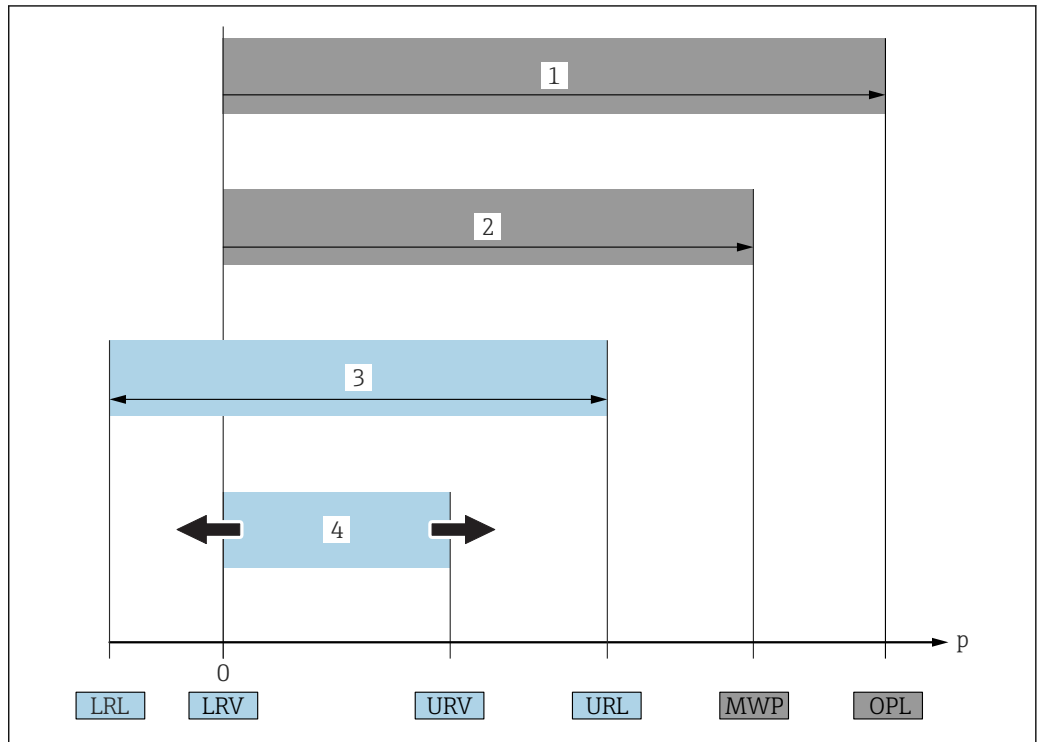

A0029505

Item	Term/ abbreviation	Explanation
1	OPL	The OPL (over pressure limit = sensor overload limit) for the measuring device depends on the lowest-rated element, with regard to pressure, of the selected components, i.e. the process connection has to be taken into consideration in addition to the measuring cell. Also observe pressure-temperature dependency. For the relevant standards and additional notes, see the "Pressure specifications" section → 18 . The OPL may only be applied for a limited period of time.
2	MWP	The MWP (maximum working pressure) for the sensors depends on the lowest-rated element, with regard to pressure, of the selected components, i.e. the process connection has to be taken into consideration in addition to the measuring cell. Also observe pressure-temperature dependency. For the relevant standards and additional notes, see the "Pressure specifications" section → 18 . The MWP may be applied at the device for an unlimited period. The MWP can also be found on the nameplate.
3	Maximum sensor measuring range	Span between LRL and URL This sensor measuring range is equivalent to the maximum calibratable/adjustable span.
4	Calibrated/ adjusted span	Span between LRV and URV Factory setting: 0 to URL Other calibrated spans can be ordered as customized spans.
p	-	Pressure
-	LRL	Lower range limit
-	URL	Upper range limit
-	LRV	Lower range value
-	URV	Upper range value
-	TD (turn down)	Turn down The turn down is preset at the factory and cannot be changed. Example - see the following section.

Turn down calculation

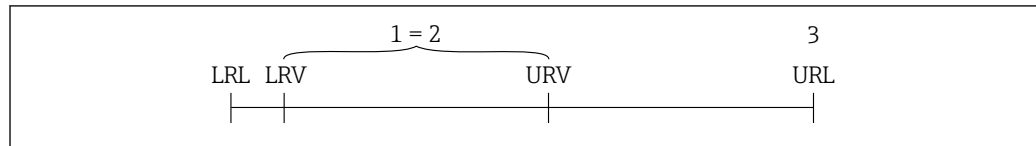

A0029545

- 1 Calibrated/adjusted span
- 2 Zero point-based span
- 3 URL sensor

Example

- Sensor: 10 bar (150 psi)
- Upper range value (URL) = 10 bar (150 psi)
- Lower range value (LRV) = 0 bar (0 psi)
- Upper range value (URV) = 5 bar (75 psi)
- Calibrated/adjusted span: 0 to 5 bar (0 to 75 psi)
- Lower range value (LRV) = 0 bar (0 psi)
- Upper range value (URV) = 5 bar (75 psi)

Turn down (TD):

$$TD = \frac{URL}{|URV - LRV|}$$

$$TD = \frac{10 \text{ bar (150 psi)}}{|5 \text{ bar (75 psi)} - 0 \text{ bar (0 psi)}|} = 2$$

In this example, the TD is 2:1.
This span is based on the zero point.

Function and system design

Measuring principle - process pressure measurement

Devices with metallic process isolating diaphragm

The process pressure deflects the metal process isolating diaphragm of the sensor and a fill fluid transfers the pressure to a Wheatstone bridge (semiconductor technology). The pressure-dependent change in the bridge output voltage is measured and evaluated.

Advantages:

- Can be used for high process pressures
- Fully welded sensor
- Slim, flush-mounted process connections available

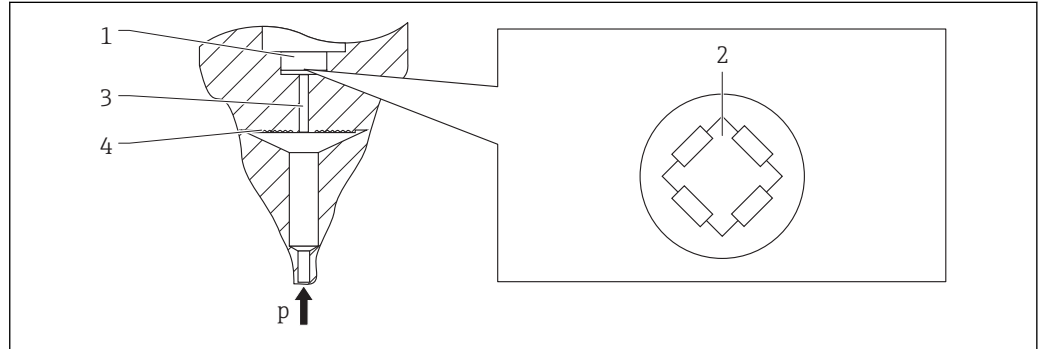

A0016448

- 1 Silicon measuring element, substrate
- 2 Wheatstone bridge
- 3 Channel with fill fluid
- 4 Metal process isolating diaphragm

Measuring system

A complete measuring system comprises, for example:

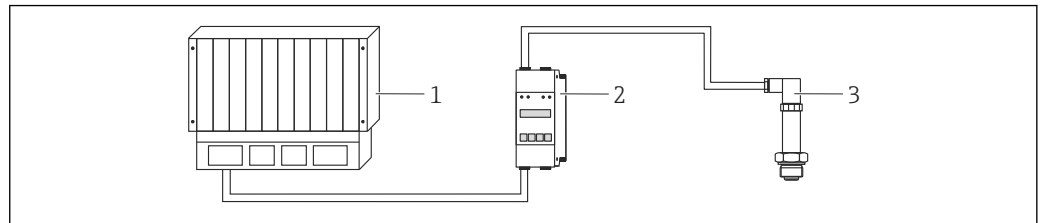

A0021926

- 1 PLC (programmable logic control)
- 2 RN221N / RMA42
- 3 Pressure transducer

Device features

	PMP23
Field of application	<ul style="list-style-type: none"> ▪ Gauge pressure and absolute pressure ▪ Hygiene applications
Process connections	<ul style="list-style-type: none"> ▪ Thread ISO 228 ▪ Clamp/Tri-Clamp ▪ DIN 11851 ▪ Thread M24 x 1.5 ▪ Universal adapter ▪ SMS ▪ Varivent
Measuring ranges	From -400 to +400 mbar (-6 to +6 psi) to -1 to +40 bar (-15 to +600 psi).
OPL (depends on the measuring range)	Max. 0 to +160 bar (0 to +2400 psi)
Process temperature range	-10 to +100 °C (+14 to +212 °F) (+135 °C (+275 °F) for one hour maximum)
Ambient temperature range	<ul style="list-style-type: none"> ▪ -40 to +85 °C (-40 to +185 °F) ▪ Devices for hazardous areas: -40 to +70 °C (-40 to +158 °F)
Reference accuracy	0.3 %, TD 5:1
Supply voltage	10 to 30 V DC
Output	4 to 20 mA
Material	<ul style="list-style-type: none"> ▪ Housing made from 316L (1.4404) ▪ Process connections made from 316L (1.4435) ▪ Process isolating diaphragm made from 316L (1.4435)
Options	<ul style="list-style-type: none"> ▪ Ex approvals ▪ Min. alarm current setting ▪ 3.1 Material certificates ▪ EHEDG/3A approvals ▪ Weld-in adapter ▪ IP69

Product design

Overview	Item	Description
<p>The overview image shows six components labeled A through E. A: Valve plug (A0027231). B: Cable (A0027232). C-1: M12 plug with a plastic housing cap (A0021987). C-2: M12 plug with a metal housing cap (A0027289). D: Housing (A0027227). E: Process connection (sample illustration).</p>	A	Valve plug
	B	Cable
	C- 1	M12 plug Housing cap made of plastic
	C- 2	M12 plug For Ex eC and IP69: metal housing cap Metal housing cap can also be ordered as an option.
	D E	Housing Process connection (sample illustration)

System integration

The device can be given a tag name (max. 8 alphanumeric characters).

Description	Option ¹⁾
Measuring point (TAG), see additional specifications	Z1

1) Product Configurator, order code for "Identification"

Input

Measured variable **Measured process variable**
PMP23: gauge pressure or absolute pressure

Calculated process variable
Pressure

Measuring range **Metal process isolating diaphragm**

Sensor	Device	Maximum Sensor measuring range		Lowest calibratable span ¹⁾	MWP	OPL	Factory settings ²⁾	Option ³⁾
		lower (LRL)	upper (URL)					
		[bar (psi)]	[bar (psi)]					
Devices for gauge pressure measurement								
400 mbar (6 psi) ⁴⁾	PMP23	-0.4 (-6)	+0.4 (+6)	0.4 (0.6)	1 (15)	1.6 (24)	0 to 400 mbar (0 to 6 psi)	1F
1 bar (15 psi) ⁴⁾	PMP23	-1 (-15)	+1 (+15)	1 (15)	2.7 (40.5)	4 (60)	0 to 1 bar (0 to 15 psi)	1H
2 bar (30 psi) ⁴⁾	PMP23	-1 (-15)	+2 (+30)	0.4 (0.6)	6.7 (100.5)	10 (150)	0 to 2 bar (0 to 30 psi)	1K
4 bar (60 psi) ⁴⁾	PMP23	-1 (-15)	+4 (+60)	0.8 (1.2)	10.7 (160.5)	16 (240)	0 to 4 bar (0 to 60 psi)	1M
6 bar (90 psi) ⁴⁾	PMP23	-1 (-15)	+6 (+90)	2 (30)	16 (240)	24 (360)	0 to 6 bar (0 to 90 psi)	1N
10 bar (150 psi) ⁴⁾	PMP23	-1 (-15)	+10 (+150)	2 (30)	25 (375)	40 (600)	0 to 10 bar (0 to 150 psi)	1P
16 bar (240 psi) ⁴⁾	PMP23	-1 (-15)	+16 (+240)	5 (75)	25 (375)	64 (960)	0 to 16 bar (0 to 240 psi)	1Q
25 bar (375 psi) ⁴⁾	PMP23	-1 (-15)	+25 (+375)	5 (75)	25 (375)	100 (1500)	0 to 25 bar (0 to 375 psi)	1R
40 bar (600 psi) ⁴⁾	PMP23	-1 (-15)	+40 (+600)	8 (120)	100 (1500)	160 (2400)	0 to 40 bar (0 to 600 psi)	1S
Devices for absolute pressure measurement								
400 mbar (6 psi) ⁴⁾	PMP23	0 (0)	0.4 (+6)	0.4 (0.6)	1 (15)	1.6 (24)	0 to 400 mbar (0 to 6 psi)	2F
1 bar (15 psi) ⁴⁾	PMP23	0 (0)	1 (+15)	1 (15)	2.7 (40.5)	4 (60)	0 to 1 bar (0 to 15 psi)	2H
2 bar (30 psi) ⁴⁾	PMP23	0 (0)	2 (+30)	0.4 (0.6)	6.7 (100.5)	10 (150)	0 to 2 bar (0 to 30 psi)	2K
4 bar (60 psi) ⁴⁾	PMP23	0 (0)	4 (+60)	0.8 (1.2)	10.7 (160.5)	16 (240)	0 to 4 bar (0 to 60 psi)	2M
10 bar (150 psi) ⁴⁾	PMP23	0 (0)	10 (+150)	2 (30)	25 (375)	40 (600)	0 to 10 bar (0 to 150 psi)	2P
40 bar (600 psi) ⁴⁾	PMP23	0 (0)	+40 (+600)	8 (120)	100 (1500)	160 (2400)	0 to 40 bar (0 to 600 psi)	2S

1) Highest turn down that can be set at the factory: 5:1. The turn down is preset and cannot be changed.

2) Other measuring ranges (e.g. -1 to +5 bar (-15 to 75 psi)) can be ordered with customer-specific settings (see the Product Configurator, order code for "Calibration; Unit" option "J"). It is possible to invert the output signal (LRV = 20 mA; URV = 4 mA). Prerequisite: URV < LRV

3) Product Configurator, order code for "Sensor range"

4) Vacuum resistance: 0.01 bar (0.145 psi)

Maximum turn down which can be ordered for absolute pressure and gauge pressure sensors

Device	Range	400 mbar (6 psi)	1 bar (15 psi) 6 bar (90 psi) 16 bar (240 psi)	2 bar (30 psi) 4 bar (60 psi) 10 bar (150 psi) 25 to 400 bar (375 to 6000 psi)
PMP23	0.3%	TD 1:1	TD 1:1 to TD 2.5:1	TD 1:1 to TD 5:1

Output

Output signal	Description	Option ¹⁾
	4 to 20 mA (2-wire)	1

1) Product Configurator, order code for "Output"

Signal range 4 to 20 mA 3.8 mA to 20.5 mA

Load (for 4 to 20 mA devices)

In order to guarantee sufficient terminal voltage in two-wire devices, a maximum load resistance R_{Lmax} (including line resistance) must not be exceeded, depending on the supply voltage U_B of the supply unit.

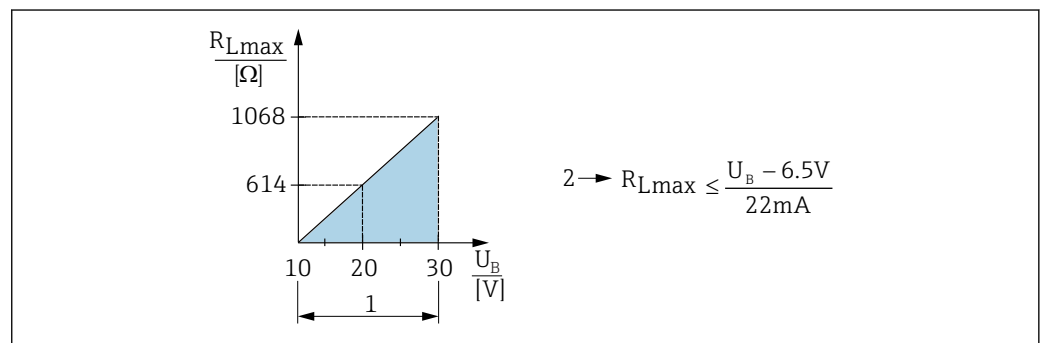

A0029452

- 1 Power supply 10 to 30 V DC
- 2 R_{Lmax} maximum load resistance
- U_B Supply voltage

Load resistance (for 0 to 10 V devices) The load resistance must be ≥ 5 [kΩ].

Signal on alarm 4 to 20 mA The response of the output to error is regulated in accordance with NAMUR NE43.
 Factory setting MAX alarm: >21 mA

alarm current

Device	Description	Option
PMP23	Adjusted min. alarm current	IA ¹⁾

1) Product Configurator order code for "Service"

Dead time, time constant Presentation of the dead time and the time constant:

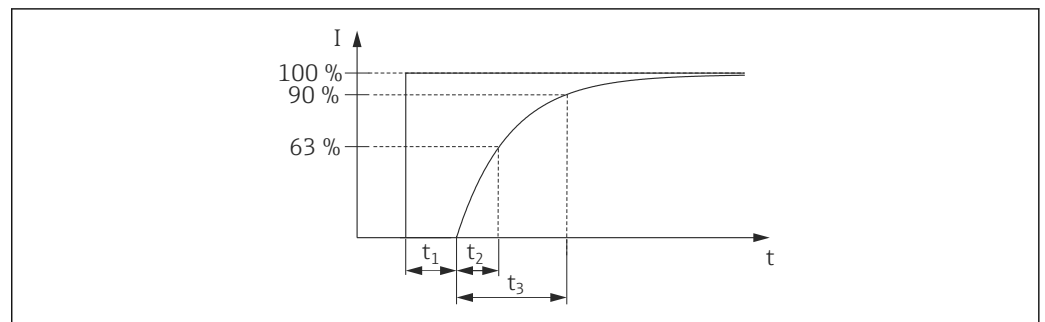

A0019786

Dynamic behavior**Analog electronics**

Dead time (t_1) [ms]	Time constant (T63), t_2 [ms]	Time constant (T90), t_3 [ms]
6 ms	10 ms	15 ms

Power supply

⚠ WARNING

Limitation of electrical safety due to incorrect connection!

- ▶ In accordance with IEC/EN61010 a separate circuit breaker must be provided for the device .
- ▶ When using the measuring device in hazardous areas, installation must comply with the corresponding national standards and regulations and the Safety Instructions or Installation or Control Drawings.
- ▶ All explosion protection data are given in separate documentation which is available upon request. The Ex documentation is supplied as standard with all devices approved for use in explosion hazardous areas.
- ▶ Protective circuits against reverse polarity, HF influences and overvoltage peaks are integrated.
- ▶ The device must be operated with a 500 mA fine-wire fuse (slow-blow).

Terminal assignment

4 to 20 mA output

Device	M12 plug	Valve plug	Cable
PMP23	<p>A0023487</p>	<p>A0022823</p>	<p>A0023783</p> <p>1 brown = L+ 2 blue = L- 3 green/yellow = ground connection (a) reference air hose</p>

Supply voltage

Electronic version	Device	Supply voltage
4 to 20 mA output	PMP23	10 to 30 V DC

Current consumption and alarm signal

Number of wires	Device	Normal operation	Alarm signal ¹⁾
2	PMP23	≤ 26 mA	> 21 mA

1) For MAX alarm (factory setting)

Power supply fault

- Behavior in the event of overvoltage (>30 V):
The device works continuously up to 34 V DC without damage. If the supply voltage is exceeded, the specified characteristics are no longer guaranteed.
- Behavior in the event of undervoltage:
If the supply voltage falls below the minimum value, the device switches off in a defined manner (status same as for no power supply).

Electrical connection

Degree of protection

Device	Connection	Climate class	Option ¹⁾
PMP23	Cable 5 m (16 ft)	IP66/68 ²⁾ NEMA Type 4X/6P Enclosure	A
PMP23	Cable 10 m (33 ft)	IP66/68 ²⁾ NEMA Type 4X/6P Enclosure	B
PMP23	Cable 25 m (82 ft)	IP66/68 ²⁾ NEMA Type 4X/6P Enclosure	C
PMP23	M12 plug made of plastic	IP65/67 NEMA type 4X enclosure	M
PMP23	M12 plug made of metal	IP66/69 ³⁾ NEMA type 4X enclosure	N

Device	Connection	Climate class	Option ¹⁾
PMP23	Valve plug ISO4400 M16	IP65 NEMA type 4X enclosure	U
PMP23	Valve plug ISO4400 NPT ½	IP65 NEMA type 4X enclosure	V

- 1) Product Configurator, order code for "Electrical connection"
- 2) IP 68 (1.83 mH₂O for 24 h)
- 3) Designation of the IP protection class according to DIN EN 60529. Previous designation "IP69K" according to DIN 40050 Part 9 is no longer valid (standard withdrawn on November 1, 2012). The tests required by both standards are identical.

Cable specification For valve plug: < 1.5 mm² (16 AWG) and Ø3.5 to 6.5 mm (0.14 to 0.26 in)

Residual ripple The device operates within the reference accuracy up to ±5 % of the residual ripple of the supply voltage, within the permitted voltage range.

Influence of power supply ≤0.005 % of the URL/1 V

Overvoltage protection The device does not contain any special elements to protect against overvoltage ("wire to ground"). Nevertheless the requirements of the applicable EMC standard EN 61000-4-5 (testing voltage 1kV EMC wire/ground) are met.

Performance characteristics of metallic process isolating diaphragm

Reference operating conditions

- As per IEC 60770
- Ambient temperature T_A = constant, in the range of: +21 to +33 °C (+70 to +91 °F)
- Humidity φ = constant, in the range of 5 to 80 % rH
- Ambient pressure p_A = constant, in the range of: 860 to 1060 mbar (12.47 to 15.37 psi)
- Position of measuring cell = constant, in range: horizontal $\pm 1^\circ$ (see also "Influence of the installation position" section → 16)
- Zero based span
- Process isolating diaphragm material: AISI 316L (1.4435)
- Filling oil: NSF-H1 synthetic oil in accordance with FDA 21 CFR 178.3570
- Supply voltage: 24 V DC ± 3 V DC
- Load: 320 Ω

Measuring uncertainty for small absolute pressure measuring ranges

- The smallest extended uncertainty of measurement that can delivered by our standards is:**
- in range 1 to 30 mbar (0.0145 to 0.435 psi): 0.4 % of reading
 - in range < 1 mbar (0.0145 psi): 1 % of reading.

Influence of the installation position

→ 16

Resolution

Current output: min. 1.6 μ A

Reference accuracy

The reference accuracy contains the non-linearity [DIN EN 61298-2 3.11] including the pressure hysteresis [DIN EN 61298-23.13] and non-repeatability [DIN EN 61298-2 3.11] in accordance with the limit point method as per [DIN EN 60770].

Device	TD ¹⁾	% of calibrated span	% of typical non-linearity	% of typical non-repeatability
PMP23	TD 1:1 to TD 5:1	± 0.3	± 0.1	± 0.1

1) Overview of the turn down ranges → 10

Thermal change of the zero output and the output span

Measuring cell	-10 to +85 °C (+14 to +185 °F)	+85 to +100 °C (+185 to +212 °F)
	% of the calibrated span for TD 1:1	
<1 bar (15 psi)	<1	<1.2
≥ 1 bar (15 psi)	<0.8	<1

Long-term stability

Measuring ranges	1 year	5 years	10 year
	% of URL		
400 mbar (6 psi) to 400 bar (6000 psi)	± 0.2	± 0.4	In preparation

Switch-on time

≤ 2 s

Installation

Installation conditions

- No moisture may enter the housing when installing or operating the device, or when establishing the electrical connection.
- Point the cable and connector downwards where possible to prevent moisture from entering (e.g. rain or condensation water).

Influence of the installation position

Any orientation is possible. However, the orientation may cause a zero point shift i.e. the measured value does not show zero when the vessel is empty or partially full.

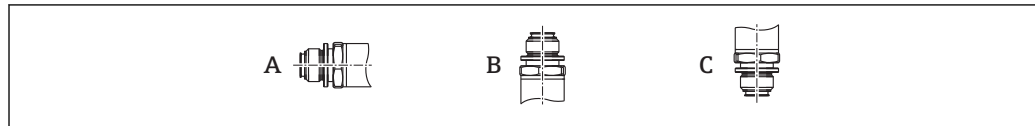

A0024708

Process isolating diaphragm axis is horizontal (A)	Process isolating diaphragm pointing upwards (B)	Process isolating diaphragm pointing downwards (C)
Calibration position, no effect	Up to +4 mbar (+0.058 psi)	Up to -4 mbar (-0.058 psi)

Mounting location

Level measurement

- Always install the device below the lowest measuring point.
- Do not install the device at the following positions:
 - In the filling curtain
 - In the tank outlet
 - In the suction area of a pump
 - Or at a point in the tank which could be affected by pressure pulses from the agitator.

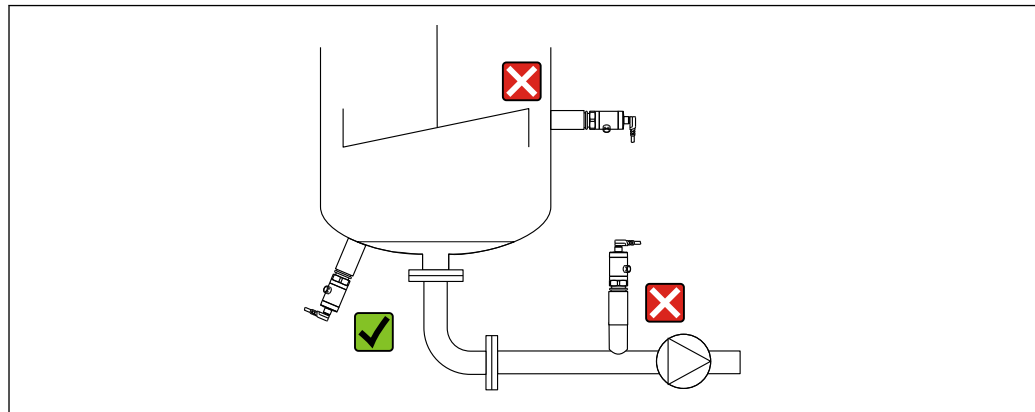

A0024405

Environment

Ambient temperature range	Device	Ambient temperature range ¹⁾
	PMP23	-40 to +85 °C (-40 to +185 °F)
	PMP23	Devices for hazardous areas: -40 to +70 °C (-40 to +158 °F)

- 1) Exception: the following cable is designed for an operating temperature range of -25 to +70 °C (-13 to +158 °F): Product Configurator order code for "Accessory enclosed", option "RZ".

Storage temperature range -40 to +85 °C (-40 to +185 °F)

Climate class	Device	Climate class	Note
	PMP23	Class 4K4H	Air temperature: -20 to +55 °C (-4 to +131 °F), relative humidity: 4 to 100 % satisfied according to DIN EN 60721-3-4 (condensation is possible)

Degree of protection	Device	Connection	Climate class	Option ¹⁾
	PMP23	Cable 5 m (16 ft)	IP66/68 ²⁾ NEMA Type 4X/6P Enclosure	A
	PMP23	Cable 10 m (33 ft)	IP66/68 ²⁾ NEMA Type 4X/6P Enclosure	B
	PMP23	Cable 25 m (82 ft)	IP66/68 ²⁾ NEMA Type 4X/6P Enclosure	C
	PMP23	M12 plug made of plastic	IP65/67 NEMA type 4X enclosure	M
	PMP23	M12 plug made of metal	IP66/69 ³⁾ NEMA type 4X enclosure	N
	PMP23	Valve plug ISO4400 M16	IP65 NEMA type 4X enclosure	U
	PMP23	Valve plug ISO4400 NPT ½	IP65 NEMA type 4X enclosure	V

- 1) Product Configurator, order code for "Electrical connection"
 2) IP 68 (1.83 mH₂O for 24 h)
 3) Designation of the IP protection class according to DIN EN 60529. Previous designation "IP69K" according to DIN 40050 Part 9 is no longer valid (standard withdrawn on November 1, 2012). The tests required by both standards are identical.

Vibration resistance	Test standard	Vibration resistance
	IEC 60068-2-64:2008	Guaranteed for 5 to 2000Hz: 0.05g ² /Hz

Electromagnetic compatibility

- Interference emission as per EN 61326-1 equipment B
- Interference immunity as per EN 61326-1 (industrial sector)
- NAMUR recommendation EMC (NE21)
- Maximum deviation: 1.5% for TD 1:1

For further details refer to the Declaration of Conformity.

Process

Process temperature range for devices with metallic process isolating diaphragm

Device	Process temperature range
PMP23	-10 to +100 °C (+14 to +212 °F)
PMP23 Sterilization in place (SIP)	At +135°C (+275 °F) for a maximum of one hour (device in operation but not within measuring specification)

Applications with changes in temperature

Frequent extreme changes in temperatures can temporarily cause measuring errors. Internal temperature compensation is faster the smaller the change in temperature and the longer the time interval.

For further information please contact your local Endress+Hauser Sales Center.

Pressure specifications

WARNING

The maximum pressure for the measuring device depends on the lowest-rated element with regard to pressure.

- ▶ For pressure specifications, see the "Measuring range" section and the "Mechanical construction" section.
- ▶ The Pressure Equipment Directive (2014/68/EU) uses the abbreviation "PS". The abbreviation "PS" corresponds to the MWP (maximum working pressure) of the measuring device.
- ▶ MWP (maximum working pressure): The MWP (maximum working pressure) is specified on the nameplate. This value is based on a reference temperature of +20 °C (+68 °F) and may be applied to the device for an unlimited period of time. Observe the temperature dependency of the MWP.
- ▶ OPL (over pressure limit): The test pressure corresponds to the over pressure limit of the sensor and may only be applied temporarily to ensure that the measurement is within the specifications and no permanent damage develops. In the case of sensor range and process connections where the over pressure limit (OPL) of the process connection is smaller than the nominal value of the sensor, the device is set at the factory, at the very maximum, to the OPL value of the process connection. If you want to use the entire sensor range, select a process connection with a higher OPL value.

Mechanical construction

Design, dimensions

Device height

The device height is calculated from

- the height of the electrical connection
- the height of the housing and
- the height of the individual process connection.

The individual heights of the components are listed in the following sections. To calculate the device height simply add up the individual heights of the components. Where applicable also take into consideration the installation distance (space that is used to install the device). You can use the following table for this purpose:

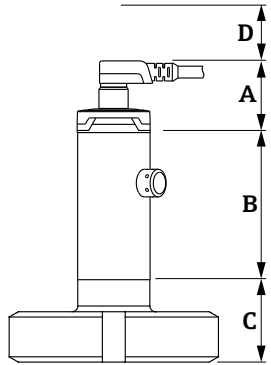
Section	Page	Height	Example
Electrical connection	→ 19	(A)	
Housing height	→ 20	(B)	
Process connection height	→ 21	(C)	
Installation distance	-	(D)	

A0027268

Electrical connection

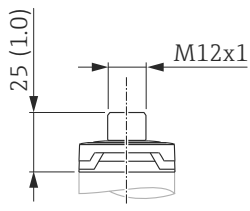
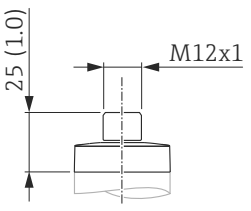
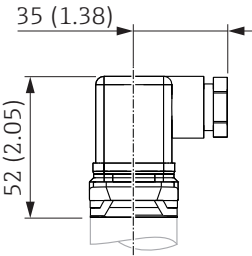
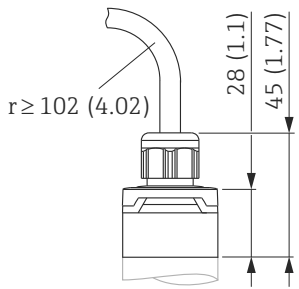
<p>A</p>  <p>A0024426</p>	<p>B</p>  <p>A0024427</p>	<p>C</p>  <p>A0024428</p>	<p>D</p>  <p>A0024429</p>
Engineering unit mm (in)			

Item	Description	Material	Weight kg (lbs)	Device	Option ¹⁾
A	M12 plug IP65/67 (Additional dimensions → 34)	Housing cap made of plastic	0.012 (0.03)	PMP23	M Plug connector with cable can be ordered as an accessory → 34
B	M12 plug IP66/67	Housing cap made of metal	0.030 (0.07)	PMP23	In the case of Ex eC type of protection, the housing cap is made of metal. Can be ordered separately via option "N".
C	M16 valve plug	Plastic PPSU	0.060 (0.14)	PMP23	U
C	NPT ½ valve plug	Plastic PPSU	0.060 (0.14)	PMP23	V
D	Cable5 m (16 ft)	PUR (UL94V0)	0.280 (0.62)	PMP23	A
D	Cable10 m (33 ft)	PUR (UL94V0)	0.570 (1.26)	PMP23	B
D	Cable25 m (82 ft)	PUR (UL94V0)	1.400 (3.09)	PMP23	C

1) Product Configurator, order code for "Electrical connection"

Housing

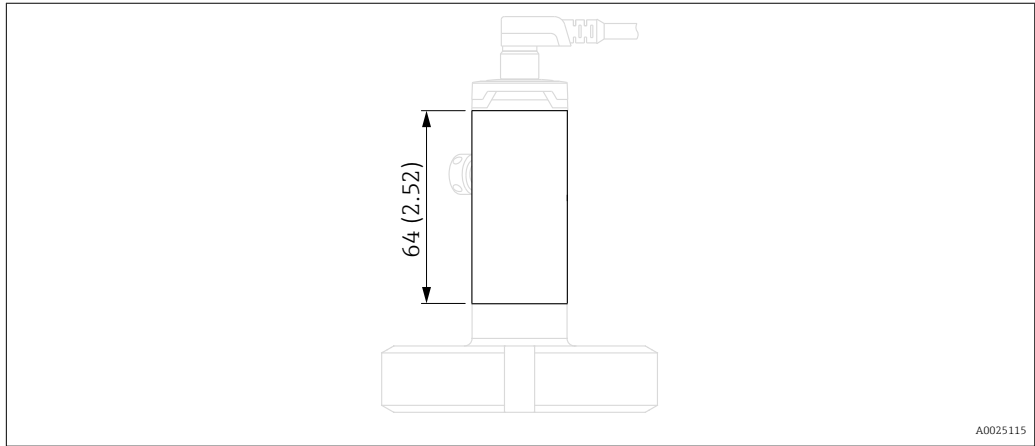

A0025115

Engineering unit mm (in)

Device	Material	Weight kg (lbs)
PMP23	Stainless steel 316L	0.100 (0.22)

Process connections with
flush-mounted, metal
process isolating diaphragm Thread ISO 228 G

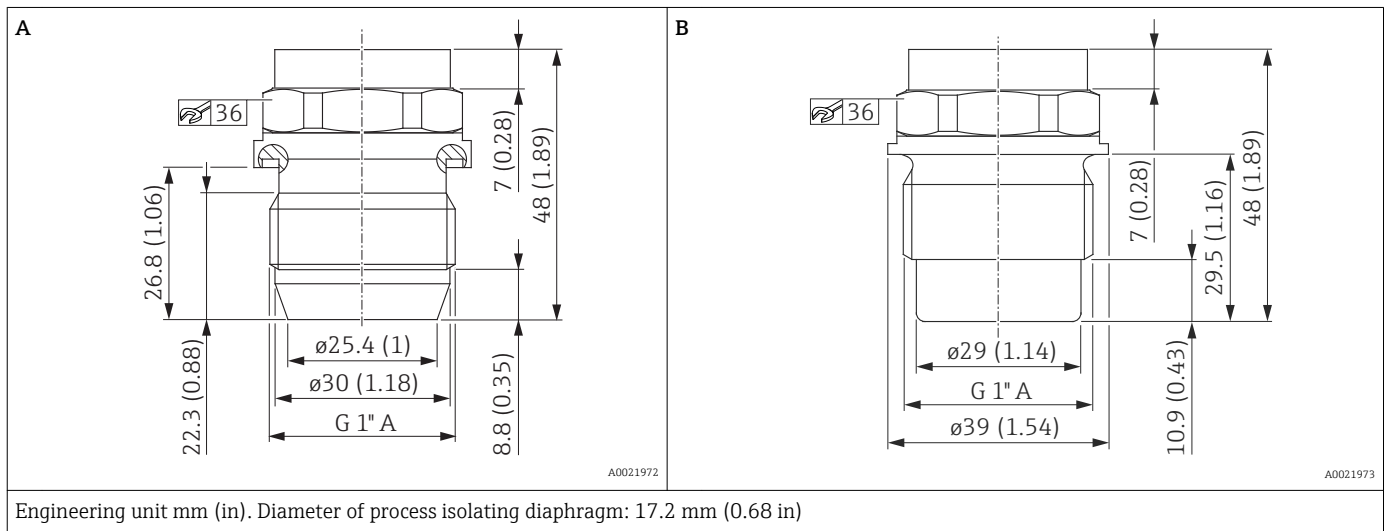

Item	Description	Seal	Material	Weight	Approval	Option ¹⁾
				kg (lbs)		
A	Thread ISO 228 G 1" A	Metal joint	316L	0.270 (0.60)	CRN	WQJ
B	Thread ISO 228 G 1" A	Seal established via O-ring. VMQ O-ring is enclosed with QJ and QK accessories.	316L	0.270 (0.60)	EHEDG, 3A ²⁾ , CRN	WSJ

- 1) Product Configurator, order code for "Process connection"
- 2) EHEDG and 3A only in conjunction with weld-in adapter → 33

Thread M24 x 1.5

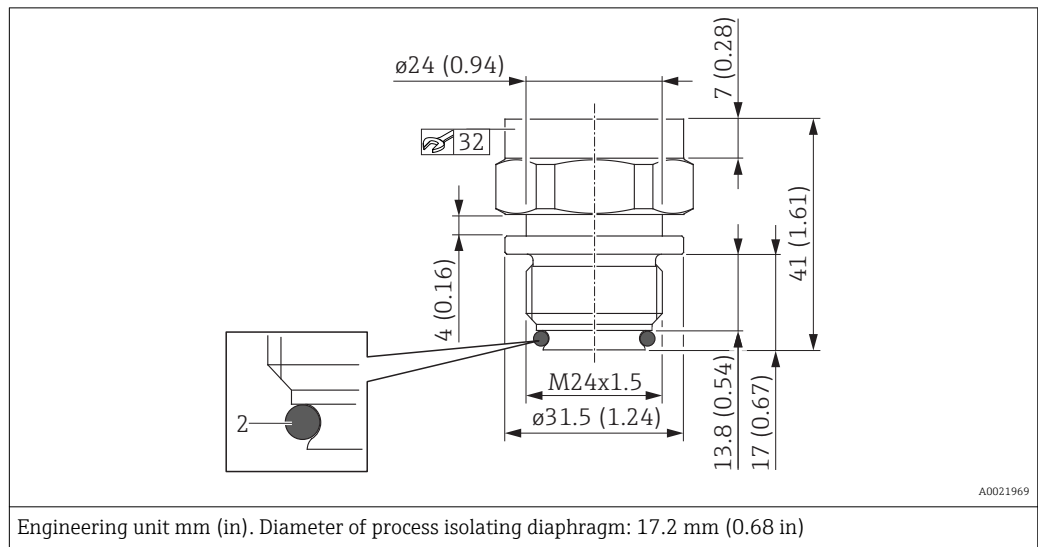

Description	Seal	Material	Weight	Approval	Option ¹⁾
			kg (lbs)		
M24 x 1.5	EPDM O-ring (2), pre-mounted	316L	0.150 (0.33)	EHEDG, 3A, CRN	X2J
M24 x 1.5	FKM O-ring (2), pre-mounted	316L	0.150 (0.33)	EHEDG, 3A, CRN	X3J

1) Product Configurator, order code for "Process connection"

Hygienic connections

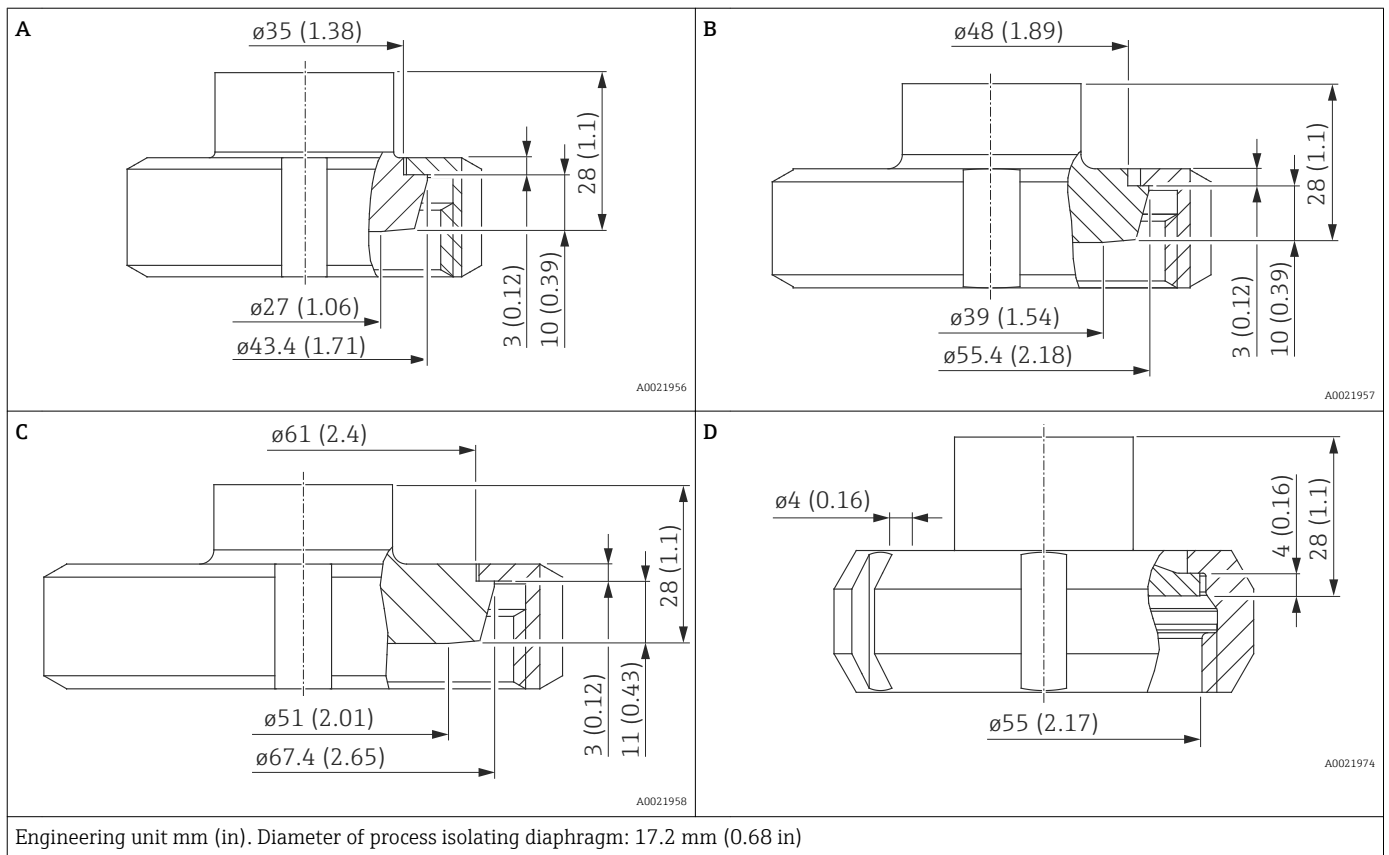

Item	Description	Approval	Nominal pressure	Material ¹⁾	Weight	Option ²⁾
			PN		kg (lbs)	
A	DIN 11851 DN 25	3A, EHEDG, CRN	40	316L	0.360 (0.79)	1GJ
B	DIN 11851 DN 40	3A, EHEDG, CRN	40	316L	0.520 (1.15)	1JJ
C	DIN 11851 DN 50	3A, EHEDG	25	316L	0.760 (1.68)	1DJ
D	SMS 1 1/2"	3A, EHEDG, CRN	25	316L	0.440 (0.97)	4QJ

- 1) Surface roughness of the surfaces in contact with the medium Ra ≤ 0.76 µm (29.9 µin).
- 2) Product Configurator, order code for "Process connection"

Hygienic connections

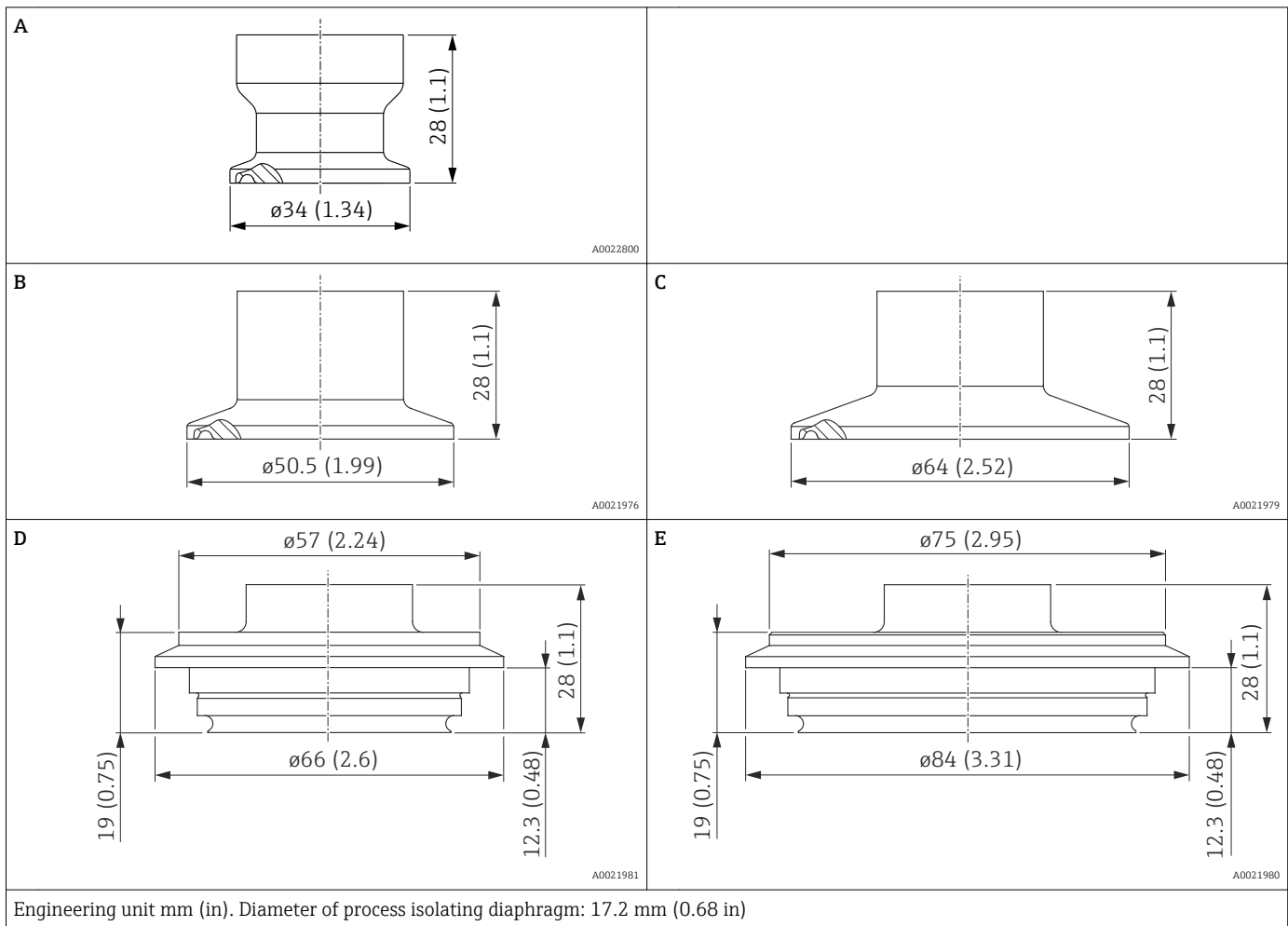

Item	Description	Approval	Nominal pressure	Material ¹⁾	Weight	Option ²⁾
			PN		kg (lbs)	
A	Clamp ISO 2852 DN 22 (¾")	3A, EHEDG, CRN	40	316L	0.090 (0.20)	3AJ
B	Tri-Clamp ISO 2852 DN 25 - DN 38 (1 ½"), DIN32676 DN25-38	3A, EHEDG, CRN	40	316L	0.160 (0.35)	3CJ
C	Tri-Clamp ISO 2852 DN 40 - DN 51 (2"), DIN32676 DN50, EHEDG, 3A	3A, EHEDG, CRN	40	316L	0.230 (0.51)	3EJ
D	Varivent F pipe DN25-32	3A, EHEDG, CRN	40	316L	0.350 (0.77)	41J
E	Varivent N pipe DN40-162	3A, EHEDG, CRN	40	316L	0.630 (1.39)	42J

1) Surface roughness of the surfaces in contact with the medium Ra ≤ 0.76 µm (29.9 µin).

2) Product Configurator, order code for "Process connection"

Hygienic connections

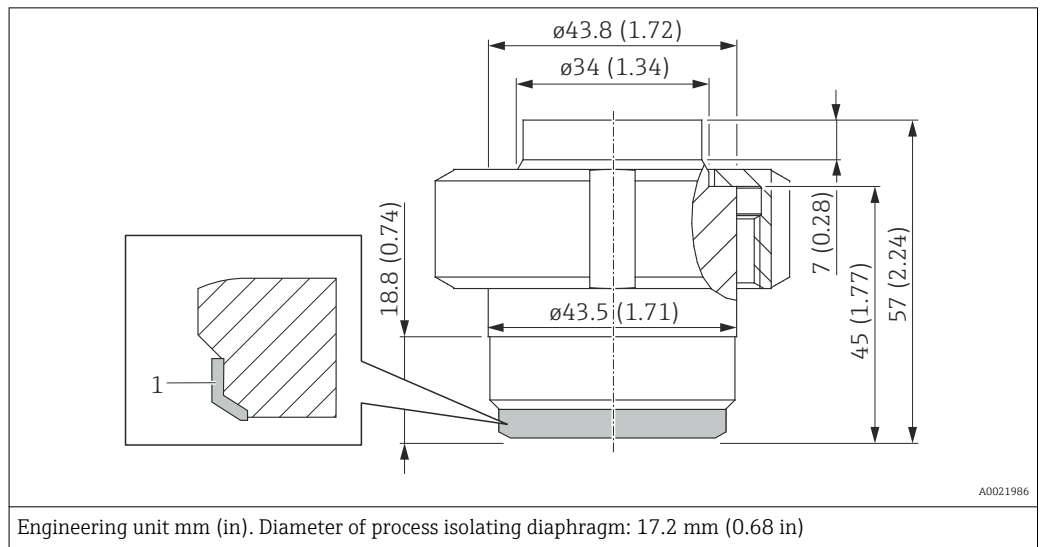

Item	Description	Seal	Approval	Nominal pressure	Material ¹⁾	Weight	Option ²⁾
				PN		kg (lbs)	
A	Universal adapter 44 mm	EPDM form seal, pre-mounted	3A, EHEDG, CRN	10	316L	0.730 (1.61)	52J

- 1) Surface roughness of the surfaces in contact with the medium Ra ≤ 0.76 μm (29.9 μin).
- 2) Product Configurator, order code for "Process connection"

Materials in contact with process**NOTICE**

- ▶ Device components in contact with the process are listed in the "Mechanical construction" and "Ordering information" sections.

TSE Certificate of Suitability

The following applies to all device components in contact with the process:

- They do not contain any materials derived from animals.
- No additives or operating materials derived from animals are used in production or processing.

Process connections

- Endress+Hauser supplies a threaded connection made of stainless steel in accordance with AISI 316L (DIN/ EN material number 1.4404 or 1.4435). With regard to their stability-temperature property, the materials 1.4404 and 1.4435 are grouped together under 13E0 in EN 1092-1: 2001 Tab. 18. The chemical composition of the two materials can be identical.
- "Clamp connections" and "Hygienic process connections": AISI 316L (DIN/EN material number 1.4435)

Process isolating diaphragm

Description	Material
Metal process isolating diaphragm	AISI 316L (DIN/EN material number 1.4435)

Seals

See the specific process connection.

Materials not in contact with process **Housing**

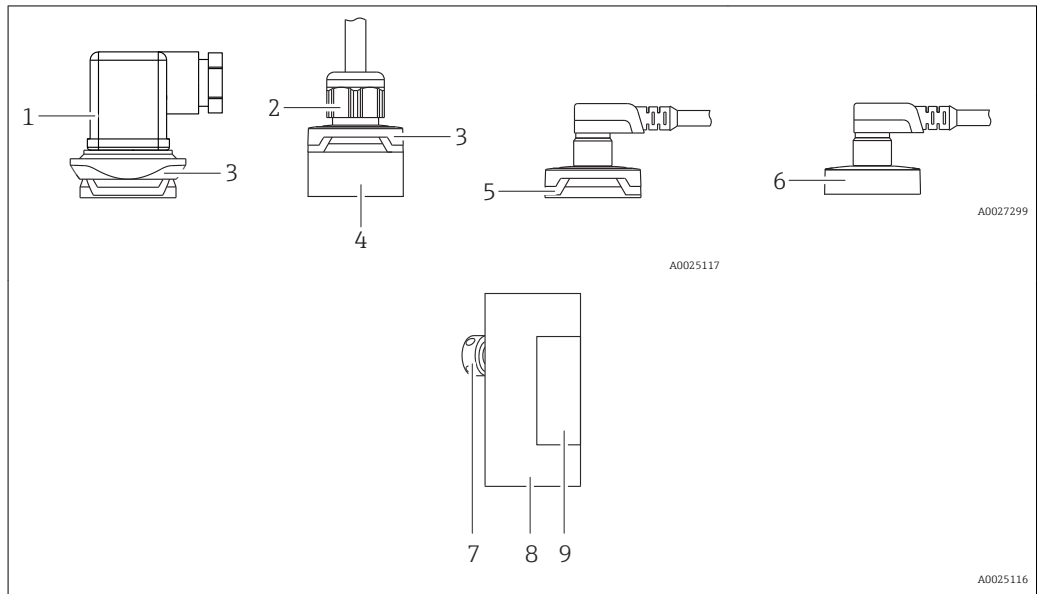

Item number	Component part	Material
1	Valve plug	<ul style="list-style-type: none"> ■ Seal: NBR ■ Plug: PA ■ Screw: V2A
2	Cable	<ul style="list-style-type: none"> ■ Pressure screw: PVDF ■ Seal: TPE-V ■ Cable: PUR (UL 94 V0)
3	Design element	PBT/PC
4	Connection	PPSU
5	M12 plug	Plastic: PPSU
6	M12 plug	Metal 316L (1.4404) Metal housing cap can be ordered as an option. For Ex eC: metal housing cap
7	Pressure compensation element	
8	Housing	316L (1.4404)
9	Nameplates	Lasered directly onto the housing

Filling oil

Device	Filling oil
PMP23	NSF-H1 synthetic oil in accordance with FDA 21 CFR 178.3570

Cleaning

Device	Description	Option ¹⁾
PMP23	Cleaned from oil+grease	HA

1) Product Configurator, order code for "Service"

Operability

Plug-on display PHX20 (optional)

No display or other operation facility is required to operate the device. However, devices with a valve plug can be fitted with the optional local display PHX20.

Description	Option ¹⁾
Plug-on display PHX20, IP65	RU

1) Product Configurator, order code for "Accessories"

A 1-line liquid crystal display (LCD) is used. The local display shows measured values, fault messages and information messages. The device display can be turned in 90° steps. Depending on the orientation of the device, it is therefore easy to read the measured values.

Technical data

Display:	4-digit, red LED display
Digit height:	7.62 mm; programmable decimal point setting
Display range:	-1999 to 9999
Accuracy:	0.2% of the span ± 1 digit
Electrical connection:	To transmitter with 4 to 20 mA output and elbow plug DIN 43 650, reverse polarity protection
Display power supply:	Not required, powered automatically from the power loop
Voltage drop:	≤ 5 V (corresponds to load: max. 250 Ω)
Rate of conversion:	3 measurements per second
Damping:	0.3 to 20 s (configurable)
Data backup:	Non-volatile EEPROM
Error message:	<ul style="list-style-type: none"> ■ HI: overrange ■ LO: below range
Programming:	Via 2 keys, menu-guided, display range scaling, decimal point, damping, error message
Degree of protection:	IP 65
Influence of temperature on the display:	0.1% / 10 K
Electromagnetic compatibility (EMC):	Interference emission as per EN 50081, interference immunity as per EN 50082
Permitted current load:	Max. 60 mA
Ambient temperature:	0 to +60 °C (+32 to +140 °F)
Housing material:	Pa6 GF30 plastic, blue Front screen made from red PMMA
Order number:	52022914

Certificates and approvals

CE mark The device meets the legal requirements of the relevant EC directives. Endress+Hauser confirms that the device has been successfully tested by applying the CE mark.

RCM-Tick marking The supplied product or measuring system meets the ACMA (Australian Communications and Media Authority) requirements for network integrity, interoperability, performance characteristics as well as health and safety regulations. Here, especially the regulatory arrangements for electromagnetic compatibility are met. The products are labelled with the RCM- Tick marking on the name plate.



A0029561

EAC conformity The PMP21 and PMP23 devices meet the legal requirements of the applicable EAC directives. These are listed in the corresponding EAC Declaration of Conformity along with the standards applied. Endress+Hauser confirms successful testing of the device by affixing to it the EAC mark.

Approval CSA C/US General Purpose

Safety Instructions (XA) Safety Instructions (XA) are supplied with the device depending on the approval. These instructions are an integral part of the Operating Instructions.

Device	Directive	Documentation	Option ¹⁾
PMP23	ATEX II 1/2G Ex ia IIC T4 Ga/Gb	XA01271P	BA
PMP23	FM IS Cl. I, Div.1 Gr. A-D T4	XA01321P	FA
PMP23	CSA C/US IS Cl. I Div. 1 Gr. A-D	XA01322P	CB
PMP23	EAC Ex ia IIC T4 Ga/Gb	XA01540P	GA
PMP23	IEC Ex ia IIC T4 Ga/Gb	XA01271P	IA
PMP23	NEPSI Ex ia IIC T4	XA01363P	NA
PMP23	TIIS Ex ia IIC T4	In preparation	TA

1) Product Configurator, order code for "Approval"

 The nameplate provides information on the Safety Instructions (XA) that are relevant for the device.

Suitability for hygienic processes All materials in contact with foodstuffs comply with framework regulation (EC) 1935/2004. The device is available with hygienic process connections (overview: see order code).

CAUTION

Contamination in the process!

Risk of contamination if incorrect seals and parts are used!

- ▶ To avoid the risk of contamination, when installing the device comply with the design principles of EHEDG, Guideline 37 "Hygienic Design and Application of Sensors" and Guideline 16 "Hygienic Pipe Couplings".
- ▶ Suitable assemblies and seals must be used to ensure hygienic design in accordance with 3-A SSI and EHEDG specifications.
- ▶ The leak-proof connections can be cleaned with the cleaning methods typical of this industry (CIP and SIP). Attention must be paid to the pressure and temperature specifications of the sensor and process connections for CIP and SIP processes (clean in place/sterilize in place).

 The seamless connections can be cleaned of all residue using any of the typical cleaning methods within this industry.

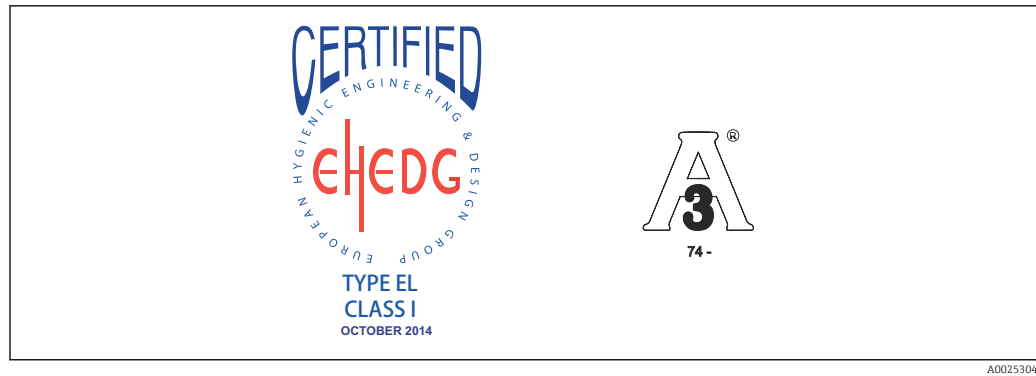

Pressure Equipment Directive 2014/68/EU (PED)

Pressure equipment with allowable pressure ≤ 200 bar (2 900 psi)

Pressure equipment (having a maximum allowable pressure $PS \leq 200$ bar (2 900 psi)) can be classified as pressurized equipment in accordance with Pressure Equipment Directive 2014/68/EU. If the maximum allowable pressure is ≤ 200 bar (2 900 psi) and the pressurized volume of the pressure equipment is ≤ 0.1 l, the pressure equipment is subject to the Pressure Equipment Directive (cf. Pressure Equipment Directive 2014/68/EU, Article 4, point 3). The Pressure Equipment Directive only requires that the pressure equipment shall be designed and manufactured in accordance with the "sound engineering practice of a Member State".

Reasons:

- Pressure Equipment Directive (PED) 2014/68/EU Article 4, point 3
- Pressure equipment directive 2014/68/EU, Commission's Working Group "Pressure", Guideline A-05 + A-06

Note:

A partial examination shall be performed for pressure instruments that are part of safety equipment for the protection of a pipe or vessel from exceeding allowable limits (equipment with safety function in accordance with Pressure Equipment Directive 2014/68/EU, Article 2, point 4).

Pressure equipment with allowable pressure > 200 bar (2 900 psi)

Pressure equipment designated for application in every process fluid having a pressurized volume of < 0.1 l and a max. allowable pressure $PS > 200$ bar (2 900 psi) shall satisfy the essential safety requirements set out in Annex I of the Pressure Equipment Directive 2014/68/EU. According to Article 13 pressure equipment shall be classified by category in accordance with Annex II. The conformity assessment of the pressure equipment shall be determined by the category I under consideration of the above-mentioned low pressurized volume. These devices shall be provided with CE marking.

Reasons:

- Pressure Equipment Directive 2014/68/EU, Article 13, Annex II
- Pressure equipment directive 2014/68/EU, Commission's Working Group "Pressure", Guideline A-05

Note:

A partial examination shall be performed for pressure instruments that are part of safety equipment for the protection of a pipe or vessel from exceeding allowable limits (equipment with safety function in accordance with Pressure Equipment Directive 2014/68/EU, Article 2, point 4).

Manufacturer declarations

Depending on the desired configuration, the following documents can be ordered additionally with the device:

- FDA conformity
- TSE-free: materials free from animal origin
- Regulation (EC) No. 2023/2006 (GMP)
- Regulation (EC) No. 1935/2004 on materials and articles intended to come into contact with food

Downloading the Declaration of Conformity

<http://www.endress.com/en/download>

A0031778

1. Select "Approvals & Certificates"
2. Select "Manufact. Declaration"
3. Enter the required product code
4. Click "Search"

The available downloads are displayed.

Other standards and guidelines

The applicable European guidelines and standards can be found in the relevant EU Declarations of Conformity. The following were also applied:

DIN EN 60770 (IEC 60770):

Transmitters for use in industrial process control systems Part 1: Methods for performance evaluation

Methods for evaluating the performance of transmitters for control and regulation in industrial process control systems.

DIN 16086:

Electrical pressure measuring instruments, pressure sensors, pressure transmitters, pressure measuring instruments, concepts, specifications on data sheets

Procedure for writing specifications in data sheets for electrical pressure measuring instruments, pressure sensors and pressure transmitters.

EN 61326-X:

EMC product family standard for electrical equipment for measurement, control and laboratory use.

EN 60529:

Degrees of protection provided by enclosures (IP code)

NAMUR - User association of automation technology in process industries.

NE21 - Electromagnetic Compatibility (EMC) of Industrial Process and Laboratory Control Equipment.

NE43 - Standardization of the Signal Level for the Failure Information of Digital Transmitters.

NE44 - Standardization of Status Indicators on PCT Instruments with the Help of Light Emitting Diodes

NE53 - Software of Field Devices and Signal-processing Devices with Digital Electronics

CRN approval

A CRN approval is available for some device versions. A CRN-approved process connection with a CSA approval must be ordered for a CRN-approved device. The CRN-approved devices are assigned the registration number 0F18141.5C.

Ordering information: Product Configurator, order code for "Process connection" (the CRN process connections are indicated appropriately in the "Mechanical construction" section.)

Calibration unit	Description	Option ¹⁾
	Sensor range; %	A
	Sensor range; mbar/bar	B
	Sensor range; kPa/MPa	C
	Sensor range; psi	F
	Customer-specific; see additional spec.	J

1) Product Configurator, order code for "Calibration; unit"

Calibration	Description	Option ¹⁾
	3-point certificate of calibration	F3

1) Product Configurator order code for "Calibration"

Inspection certificates	Device	Description	Option ¹⁾
	PMP23	3.1 Material documentation, wetted metal parts, EN10204-3.1 inspection certificate	JA
	PMP23	Surface finish measurement ISO4287/Ra, wetted metal parts, inspection certificate	KB

1) Product Configurator, order code for "Test, Certificate"

Additional approval	Device	Description	Option ¹⁾
	PMP23	EHEDG, certificate copy	L1
	PMP23	3A, certificate copy	L2
	PMP23	Declaration of Conformity EC1935/2004, wetted parts	L3

1) Product Configurator, order code for "Additional approval"

Ordering information

Detailed ordering information is available from the following sources:

- In the Product Configurator on the Endress+Hauser website: www.endress.com -> Click "Corporate" -> Select your country -> Click "Products" -> Select the product using the filters and search field -> Open product page -> The "Configure" button to the right of the product image opens the Product Configurator.
- From your Endress+Hauser Sales Center: www.addresses.endress.com



Product Configurator - the tool for individual product configuration

- Up-to-the-minute configuration data
- Depending on the device: Direct input of measuring point-specific information such as measuring range or operating language
- Automatic verification of exclusion criteria
- Automatic creation of the order code and its breakdown in PDF or Excel output format
- Ability to order directly in the Endress+Hauser Online Shop

Scope of delivery	Measuring device
	Optional accessories
	Brief Operating Instructions
	Certificates

Accessories

Weld-in adapter

Various weld-in adapters are available for installation in vessels or pipes.

Device	Description	Option ¹⁾	Order number
PMP23	Weld-in adapter M24, d=65, 316L	PM	71041381
PMP23	Weld-in adapter M24, d=65, 316L 3.1 EN10204-3.1 material, inspection certificate	PN	71041383
PMP23	Weld-in adapter G1, 316L, conical metal joint	QE	52005087
PMP23	Weld-in adapter G1, 316L, 3.1, conical metal joint, EN10204-3.1 material, inspection certificate	QF	52010171
PMP23	Weld-in tool adapter G1, brass	QG	52005272
PMP23	Weld-in adapter G1, 316L, silicone O-ring seal	QJ	52001051
PMP23	Weld-in adapter G1, 316L, 3.1, silicone O-ring seal, EN10204-3.1 material, inspection certificate	QK	52011896
PMP23	Weld-in adapter Uni D65, 316L	QL	214880-0002
PMP23	Weld-in adapter Uni D65, 316L 3.1 EN10204-3.1 material, inspection certificate	QM	52010174
PMP23	Weld-in tool adapter Uni D65/D85, brass	QN	71114210
PMP23	Weld-in adapter Uni D85, 316L	QP	52006262
PMP23	Weld-in adapter Uni D85, 316L 3.1 EN10204-3.1 material, inspection certificate	QR	52010173

1) Product Configurator, order code for "Enclosed accessories"

If installed horizontally and weld-in adapters with a leakage hole are used, ensure that the leakage hole is pointing down. This allows leaks to be detected as quickly as possible.

Process adapter M24

The following process adapters can be ordered for the process connections with order option X2J and X3J:

Device	Description	Order number	Order number with inspection certificate 3.1 EN10204
PMP23	Varivent F DN32 PN40	52023996	52024003
PMP23	Varivent N DN50 PN40	52023997	52024004
PMP23	DIN11851 DN40	52023999	52024006
PMP23	DIN11851 DN50	52023998	52024005
PMP23	SMS 1½"	52026997	52026999
PMP23	Clamp 1½"	52023994	52024001
PMP23	Clamp 2"	52023995	52024002

Plug-on display PHX20

→  28

M12 plug connectors

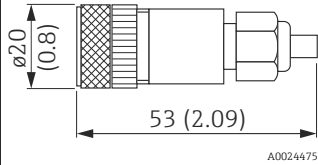
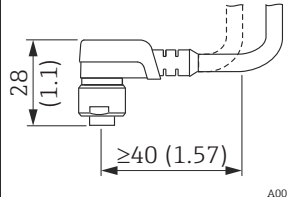
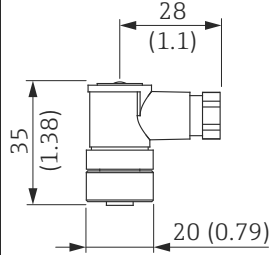
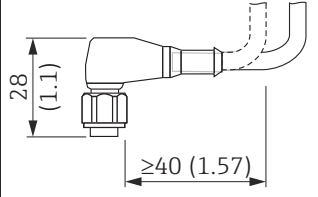
Connector	Degree of protection	Material	Option ¹⁾	Order number
M12 (self-terminated connection at M12 plug) 	IP67	<ul style="list-style-type: none"> ▪ Union nut: Cu Sn/Ni ▪ Body: PBT ▪ Seal: NBR 	R1	52006263
M12 90 degrees with 5m (16 ft) cable 	IP67	<ul style="list-style-type: none"> ▪ Union nut: GD Zn/Ni ▪ Body: PUR ▪ Cable: PVC 	RZ	52010285
M12 90 degrees (self-terminated connection at M12 plug) 	IP67	<ul style="list-style-type: none"> ▪ Union nut: GD Zn/Ni ▪ Body: PBT ▪ Seal: NBR 	RM	71114212
M12 90 degrees with 5m (16 ft) cable (terminated at one end) 	IP69 ²⁾	<ul style="list-style-type: none"> ▪ Union nut: 316L (1.4435) ▪ Body and cable: PVC and PUR 	RW	52024216

- 1) Product Configurator, order code for "Enclosed accessories"
- 2) Designation of the IP protection class according to DIN EN 60529. Previous designation "IP69K" according to DIN 40050 Part 9 is no longer valid (standard withdrawn on November 1, 2012). The tests required by both standards are identical.

Documentation

Field of Activities	Pressure measurement, powerful instruments for process pressure, differential pressure, level and flow: FA00004P/00/EN
Technical Information	<ul style="list-style-type: none"> ■ TI00241F/00/DE: EMV test procedures ■ TI00426F/00/DE: Weld-in adapters, process adapters and flanges (overview)
Operating Instructions	BA01271P/00/EN
Brief Operating Instructions	KA01164P/00/EN
Safety Instructions (XA)	Safety Instructions (XA) are supplied with the device depending on the approval. These instructions are an integral part of the Operating Instructions.

Device	Directive	Documentation	Option ¹⁾
PMP23	ATEX II 1/2G Ex ia IIC T4 Ga/Gb	XA01271P	BA
PMP23	FM IS Cl. I, Div.1 Gr. A-D T4	XA01321P	FA
PMP23	CSA C/US IS Cl. I Div. 1 Gr. A-D	XA01322P	CB
PMP23	EAC Ex ia IIC T4 Ga/Gb	XA01540P	GA
PMP23	IEC Ex ia IIC T4 Ga/Gb	XA01271P	IA
PMP23	NEPSI Ex ia IIC T4	XA01363P	NA
PMP23	TIIS Ex ia IIC T4	In preparation	TA

1) Product Configurator, order code for "Approval"



The nameplate provides information on the Safety Instructions (XA) that are relevant for the device.



www.addresses.endress.com
