

Brief Operating Instructions Gammapiilot M FMG60 HART

Radiometric measurement

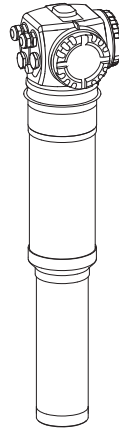

These Instructions are Brief Operating Instructions; they are not a substitute for the Operating Instructions pertaining to the device.

For detailed information, refer to the Operating Instructions and other documentation.

Available for all device versions via:

- Internet: www.endress.com/deviceviewer
- Smart phone/Tablet: Endress+Hauser Operations App

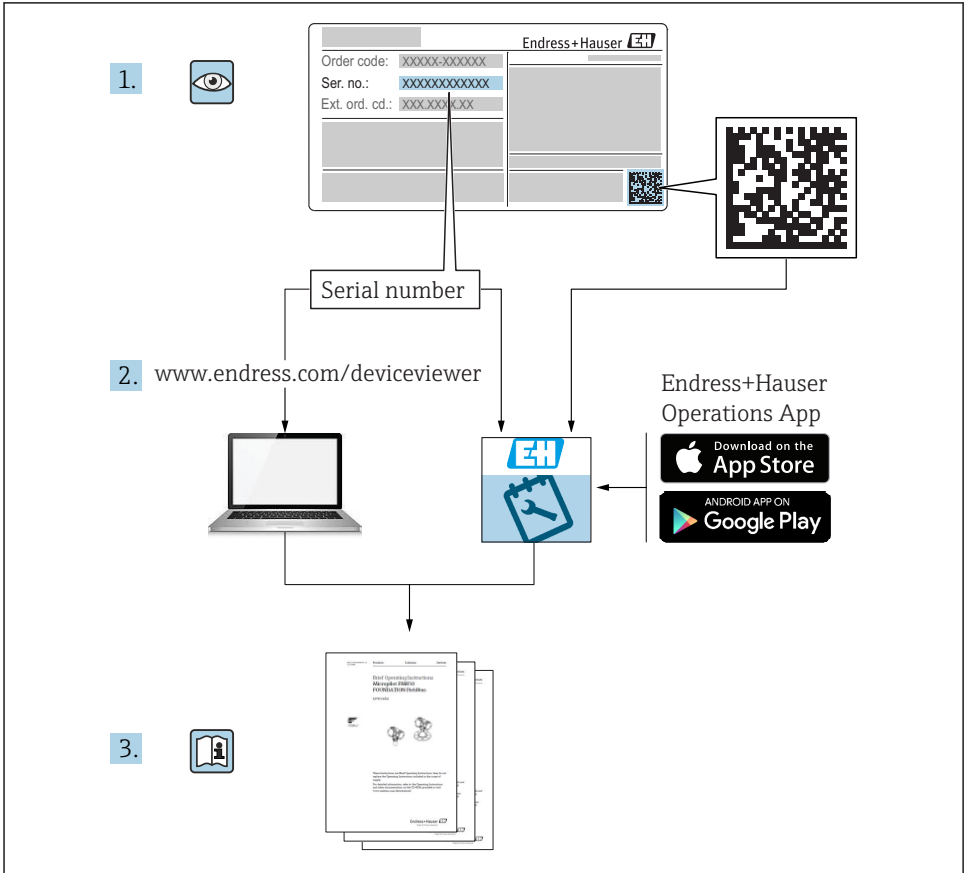

A0023555

Gammapilot M - Quick guide

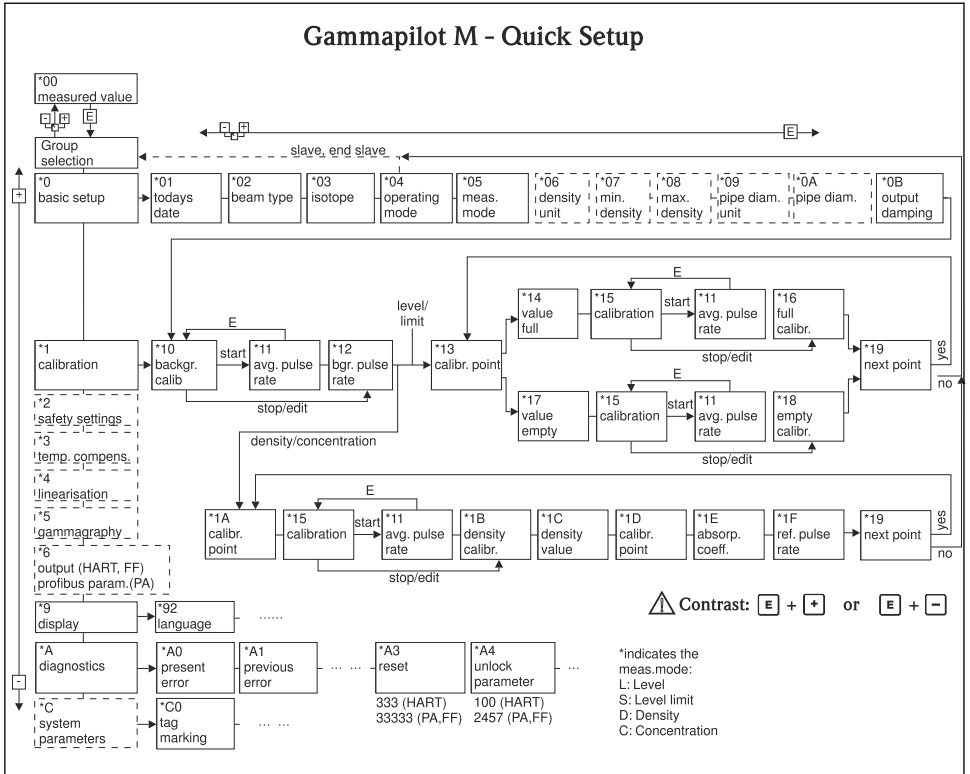

A0036818-EN





Table of contents

1	About this document	5
1.1	Symbols used	5
2	Basic safety instructions	7
2.1	Requirements for the personnel	7
2.2	Designated use	7
2.3	Installation, commissioning and operation	7
2.4	Hazardous area	7
2.5	Radiation protection	8
2.6	Workplace safety	9
2.7	Operational safety	9
2.8	Product safety	10
3	Installation	10
3.1	Incoming acceptance, product identification, transport, storage	10
3.2	Installation conditions	11
3.3	Water cooling	15
3.4	Post-installation check	15
4	Wiring	16
4.1	Connection compartments	16
4.2	Cable entries	17
4.3	Terminal assignment	18
4.4	Potential equalization	20
4.5	Wiring in connection compartment 1	21
4.6	Wiring in connection compartment 2	23
4.7	Connecting the remote display and operating unit FHX40	24
4.8	Wiring for cascade mode	25
4.9	Wiring example for point level detection 200/400 mm	25
4.10	Post-connection check	27
5	Operation	27
5.1	Display operation	27
6	Commissioning	30
6.1	Calibration: overview	31
6.2	Function check	32
6.3	Switching on the device	32
6.4	Basic setup	33
6.5	Calibration for level measurement and point level detection	39
6.6	Calibration for density and concentration measurements	49
6.7	Density measurement/temperature-compensated	58
6.8	Gammagraphy detection	58
6.9	SIL locking (for point level detection 200/400mm PVT scintillator) (HART only)	58





1 About this document

1.1 Symbols used



1.1.1 Safety symbols

Symbol	Meaning
	DANGER! This symbol alerts you to a dangerous situation. Failure to avoid this situation will result in serious or fatal injury.
	WARNING! This symbol alerts you to a dangerous situation. Failure to avoid this situation can result in serious or fatal injury.
	CAUTION! This symbol alerts you to a dangerous situation. Failure to avoid this situation can result in minor or medium injury.
	NOTICE! This symbol contains information on procedures and other facts which do not result in personal injury.















1.1.2 Electrical symbols

Symbol	Meaning
	Direct current A terminal at which DC is present or through which DC flows.
	Alternating current A terminal to which alternating voltage (sine-wave) is applied or through which alternating current flows.
	Ground connection A grounded terminal which, as far as the operator is concerned, is grounded via a grounding system.
	Protective ground connection A terminal which must be connected to ground prior to establishing any other connections.

1.1.3 Tool symbols



Symbol	Meaning
	Flat blade screwdriver
	Allen key

1.1.4 Symbols for certain types of information

Symbol	Meaning
	Permitted Procedures, processes or actions that are permitted.
	Preferred Procedures, processes or actions that are preferred.
	Forbidden Procedures, processes or actions that are forbidden.
	Tip Indicates additional information.
	Reference to documentation
	Reference to page
	Reference to graphic
	Notice or individual step to be observed
	Series of steps
	Result of a step
	Help in the event of a problem
	Visual inspection
	Operation via local display
	Operation via operating tool
	Write-protected parameter

1.1.5 Symbols in graphics

Symbol	Meaning
1, 2, 3 ...	Item numbers
	Series of steps
A, B, C, ...	Views
A-A, B-B, C-C, ...	Sections

Symbol	Meaning
	Hazardous area Indicates the hazardous area.
	Safe area (non-hazardous area) Indicates the non-hazardous area.

2 Basic safety instructions

2.1 Requirements for the personnel

The personnel must fulfill the following requirements for its tasks:

- ▶ Trained, qualified specialists must have a relevant qualification for this specific function and task.
- ▶ Are authorized by the plant owner/operator.
- ▶ Are familiar with federal/national regulations.
- ▶ Before starting work, read and understand the instructions in the manual and supplementary documentation as well as the certificates (depending on the application).
- ▶ Follow instructions and comply with basic conditions.

2.2 Designated use

The Gammapilot M is a compact transmitter for non-contact level, point level, density and concentration measurement. The measuring range of a single Gammapilot M is up to 2 m (6.6 ft). Large measuring ranges of any size can be implemented, however, by cascading several Gammapilot M devices. When used for point level detection, the Gammapilot is certified according to IEC 61508 for safety-related operation up to SIL 2/3.

2.3 Installation, commissioning and operation

The Gammapilot M is designed to meet state-of-the-art safety requirements and complies with applicable standards and EC regulations. However, if it is used improperly or for applications for which it is not intended, application-related hazards may arise, e.g. product overflow due to incorrect installation or configuration. Installation, electrical connection, commissioning, operation and maintenance of the measuring system must therefore be carried out exclusively by trained specialists authorized to perform such work by the system operator. Technical personnel must have read and understood these Operating Instructions and must adhere to them. Modifications and repairs to the device may only be carried out if they are expressly permitted in the Operating Instructions.

2.4 Hazardous area

If the measuring system is used in hazardous areas, the corresponding national standards and regulations must be observed. The device is accompanied by separate "Ex documentation", which is an integral part of these Operating Instructions. The installation specifications,

connection values and safety instructions listed in this supplementary documentation must be observed.

- Technical personnel must be suitably qualified and trained.
- Comply with the metrological and safety-related requirements for the measuring point.

⚠ WARNING

- ▶ The three screws connecting the detector pipe to the terminal housing may not be opened.

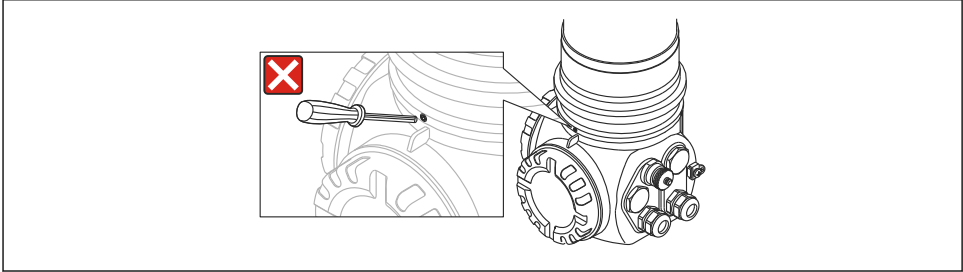

A0018068

⚠ WARNING

- ▶ The safety instructions, which depend on the certificate ordered, must be observed (Operating Instructions -> "Certificates and approvals" section)

2.5 Radiation protection

⚠ WARNING

- ▶ When working with radioactive sources, avoid any unnecessary exposure to radiation. All unavoidable radiation exposure must be kept to a minimum. Three basic concepts apply to achieve this:

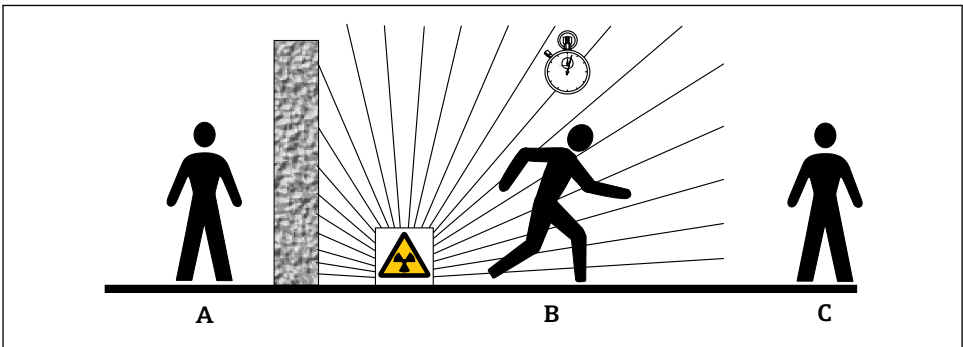

A0016373

- A *Shielding*
- B *Time*
- C *Distance*

Shielding

Ensure the best possible shielding between the radiation source and yourself and all other persons. Effective shielding is provided by source containers (FQG60, FQG61/FQG62, FQG63, QG2000) and all high-density materials (lead, iron, concrete etc.).

CAUTION

- ▶ When working with source containers, all the instructions for mounting and usage outlined in the following documents must be observed:

Source container	Document
FQG60	TI00445F/00/EN
FQG61, FQG62	TI00435F/00/EN
FQG63	TI00446F/00/EN
QG2000	TI00346F/00/EN BA00223F/00/EN

Time

The time spent in the exposed area should be kept to a minimum.

Distance

Keep as far away from the radiation source as possible. The radiation intensity decreases in proportion to the square of the distance from the radiation source.

2.6 Workplace safety

For work on and with the device:

- ▶ Wear the required personal protective equipment according to federal/national regulations.

2.7 Operational safety

Risk of injury.

- ▶ Operate the device in proper technical condition and fail-safe condition only.
- ▶ The operator is responsible for interference-free operation of the device.

Conversions to the device

Unauthorized modifications to the device are not permitted and can lead to unforeseeable dangers.

- ▶ If, despite this, modifications are required, consult with the manufacturer.

Repair

To ensure continued operational safety and reliability,

- ▶ Carry out repairs on the device only if they are expressly permitted.
- ▶ Observe federal/national regulations pertaining to repair of an electrical device.
- ▶ Use original spare parts and accessories from the manufacturer only.

Hazardous area

To eliminate a danger for persons or for the facility when the device is used in the hazardous area (e.g. explosion protection, pressure vessel safety):

- ▶ Based on the nameplate, check whether the ordered device is permitted for the intended use in the hazardous area.
- ▶ Observe the specifications in the separate supplementary documentation that is an integral part of these Instructions.

2.8 Product safety

This measuring device is designed in accordance with good engineering practice to meet state-of-the-art safety requirements, has been tested, and left the factory in a condition in which it is safe to operate.

It meets general safety standards and legal requirements. It also complies with the EC directives listed in the device-specific EC Declaration of Conformity. Endress+Hauser confirms this by affixing the CE mark to the device.

3 Installation

3.1 Incoming acceptance, product identification, transport, storage

3.1.1 Incoming acceptance

Check the packaging and contents for any signs of damage. Check the shipment, make sure nothing is missing and that the scope of supply matches your order.

3.1.2 Product identification

The measuring device can be identified in the following ways:

- Using the nameplate specifications.
- Using the order code with a breakdown of the device features on the delivery note.
- By entering the serial number of the nameplates into *W@M Device Viewer*. (www.endress.com/deviceviewer): All the information about the measuring device is displayed.

For an overview of the scope of the Technical Documentation provided:

Enter the serial number of the nameplates into *W@M Device Viewer*. (www.endress.com/deviceviewer)

3.1.3 Transport



Risk of injury

- ▶ Follow the safety instructions and transport conditions for devices weighing more than 18 kg (39.69 lb).

3.1.4 Storage

Pack the device so that it is protected against impact for storage and transport. The original packaging provides optimum protection. The permissible storage temperature is:

- -40 to +50 °C (-40 to +122 °F) for devices with PVT scintillator
- -40 to +60 °C (-40 to +140 °F) for devices with NaI crystal

3.2 Installation conditions

3.2.1 Installation conditions for level measurement

Conditions

- For level measurements the Gammapilot M is mounted vertically; if possible the detector head should point downwards
- The angle of emission of the source container must be exactly aligned to the measuring range of the Gammapilot M. Observe the measuring range marks of the Gammapilot M.
- If several Gammapilot M devices are connected in cascade mode, there should not be any gap between the individual measuring ranges.
- The source container and the Gammapilot M should be mounted as close to the vessel as possible. Any access to the beam must be blocked to ensure that it is not possible to reach into this area.
- The Gammapilot M should be protected against direct sunlight in order to increase its service life. Use a protective cover if necessary.
- The mounting device FHG60 or an equivalent mounting device should be used to secure the Gammapilot M (Operating Instructions -> "Accessories" section).
The mounting device itself must be installed in such a way that it can withstand the weight of the Gammapilot M under all anticipated conditions (e.g. vibrations). (Operating Instructions -> "Installation conditions" section)



The Gammapilot M should be given additional support to prevent damage to the connecting cable or to the unit if it falls.

Examples

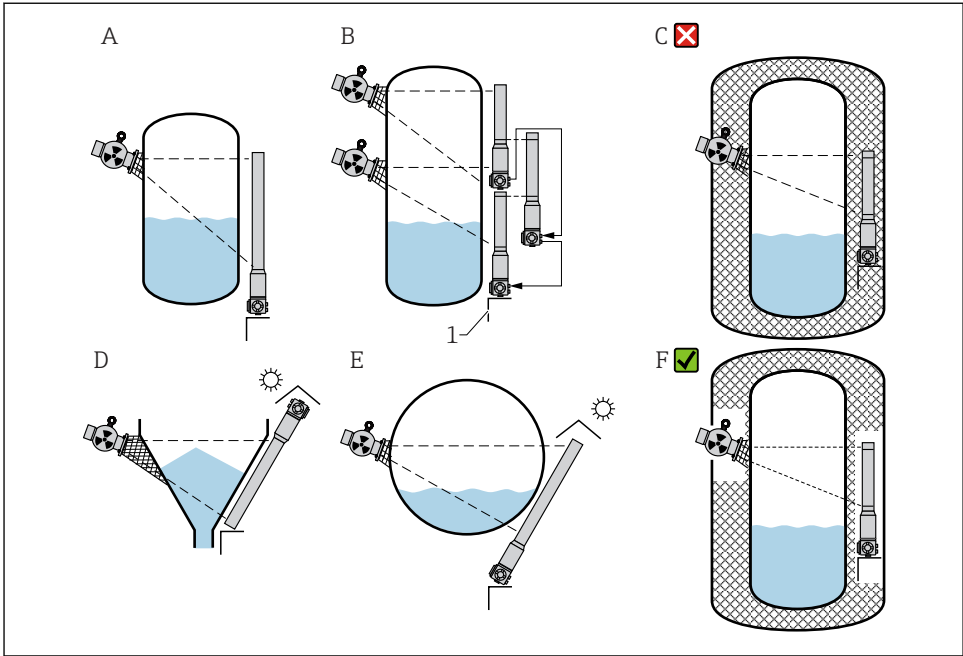

A0018074

- A Vertical cylinder; the Gammapilot M is mounted vertically with the detector head pointing downwards, the gamma ray is aligned to the measuring range.
- B Cascading of multiple Gammapilot M devices; there is no gap between the measuring ranges
- C Incorrect: Gammapilot M mounted inside the tank insulation
- D Conical vessel outlet (here with sun protection cover)
- E Horizontal cylinder (here with sun protection cover)
- F Correct: tank insulation removed for Gammapilot M
- 1 Support

3.2.2 Installation conditions for point level detection

Conditions

- For point level detection, the Gammapilot M is generally mounted horizontally at the height of the desired level limit.
- The angle of emission of the source container must be exactly aligned to the measuring range of the Gammapilot M. Observe the measuring range marks of the Gammapilot M.
- The source container and the Gammapilot M should be mounted as close to the vessel as possible. Any access to the beam must be blocked to ensure that it is not possible to reach into this area.
- The Gammapilot M should be protected against direct sunlight in order to increase its service life. Use a protective cover if necessary.
- The mounting device FHG60 or an equivalent mounting device should be used to secure the Gammapilot M (Operating Instructions -> "Accessories" section).
The mounting device itself must be installed in such a way that it can withstand the weight of the Gammapilot M under all anticipated conditions (e.g. vibrations). (Operating Instructions -> "Installation conditions" section)

 More information with regard to the safety-related use of the Gammapilot M can be found in the Functional Safety Manual SD00230F/00/EN and SD00324F/00/EN.

Examples

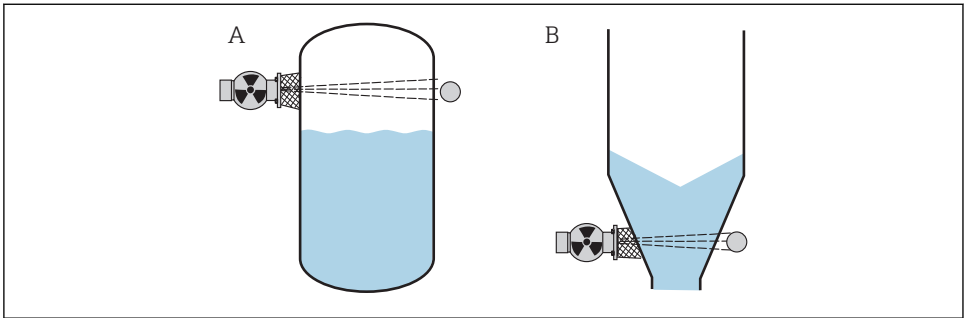

A0018075

- A *Maximum fail-safe mode*
 B *Minimum point level detection*

3.2.3 Installation conditions for density and concentration measurements

Conditions

- If possible, density and concentration should be measured on vertical pipes with forward flow from bottom to top.
- If only horizontal pipes are accessible, the path of the beam should also be arranged horizontally to minimize the influence of air bubbles and deposits.
- The Endress+Hauser clamping device FHG61 or an equivalent clamping device should be used to secure the radiation source container and the Gammapilot M to the measuring tube. The clamping device itself must be installed in such a way that it can withstand the weight of the source container and the Gammapilot M under all anticipated conditions.
- The sample point may not be further than 20 m (66 ft) from the measuring point.
- The distance of the density measurement to pipe bends is $\geq 3 \times$ pipe diameter, and $\geq 10 \times$ pipe diameter in the case of pumps.

Measuring system arrangement

The arrangement of the source container and the Gammapilot M depends on the pipe diameter (or the length of the irradiated measuring path) and the density measuring range. These two parameters determine the measuring effect (relative change in the pulse rate). The measuring effect increases with the length of the radiation path through the medium. Therefore, it is advisable to use diagonal irradiation or a measurement section for small pipe diameters.

To select the measuring system arrangement please contact your Endress+Hauser sales organization or use the Applicator™¹⁾

1) configuration software. The Applicator™ is available from your Endress+Hauser sales organization.

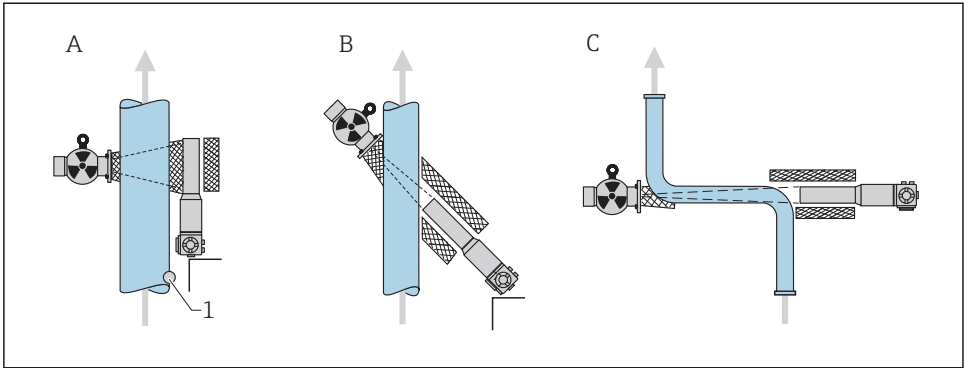

A0018076

- A Vertical beam (90°)
 B Diagonal beam (30°)
 C Measurement section
 1 Sample point



- To increase the accuracy of density measurements, the use of a collimator is recommended. The collimator screens the detector against environmental radiation.
- When planning, the total weight of the measuring system must be taken into consideration.
- The Gammapilot M should be given additional support to secure it against falling or to prevent damage to the connecting cable.
- A clamping device (FHG61) and a measurement section (FHG62) are available as accessories (Operating Instructions -> "Accessories" section)

3.3 Water cooling

See the Operating Instructions



BA00236F/00/EN

3.4 Post-installation check

After installing the measuring device, carry out the following checks:

- Is the device damaged (visual inspection)?
- Does the device match the measuring point specifications (ambient temperature, measuring range etc.)?
- If available: are the measuring point number and labeling correct (visual inspection)?
- Is the measuring device sufficiently protected against sunlight?
- Are the cable glands tightened correctly?

4 Wiring

4.1 Connection compartments

The Gammapilot M has two connection compartments

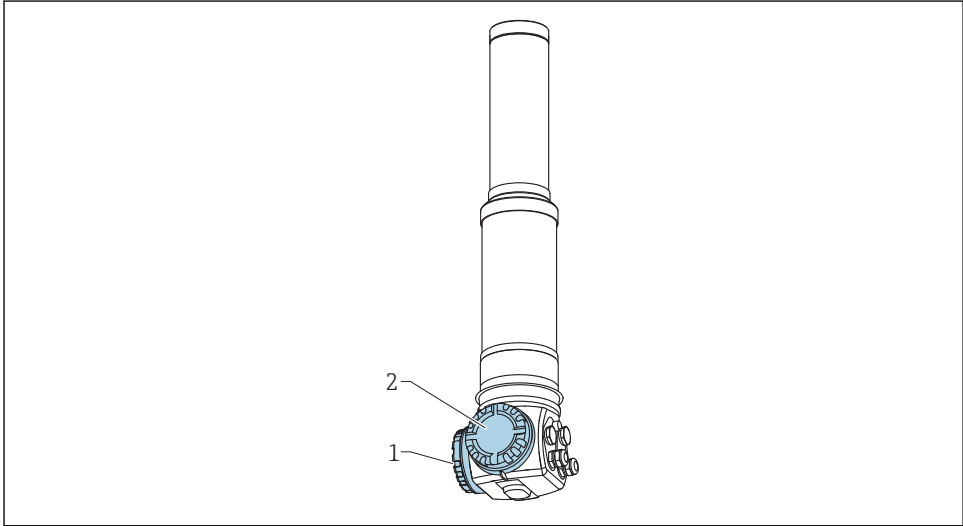

A0018082

1 Connection compartment 1

2 Connection compartment 2

Connection compartment 1

Connection compartment for:

- Power supply
- Signal output (depending on the device version)

Connection compartment 2

Connection compartment for:

- Signal output (depending on the device version)
- Pt-100 input (4-wire)
- Pulse input for cascade mode
- Pulse output for cascade mode
- Display and operating module FHX40 (or VU331)

 Depending on the device version, the signal output is located in connection compartment 1 or 2.

Maximum cable length:

- For cascade, 20 m (66 ft) per device
- For Pt-100 2 m (6.6 ft). Temperature measurement should be performed as close as possible to density measurement.

4.2 Cable entries

The number and type of cable entries depend on the device version ordered. The following are possible:

- Coupling M20x1.5, sealing range 7 to 10.5 mm (0.28 to 0.41 in)
- Cable entry M20x1.5
- Cable entry G1/2
- Cable entry NPT1/2
- M12 connector (see "Fieldbus connectors")
- 7/8" connector (see "Fieldbus connectors")

In addition, the Gammapilot M also has a socket to connect the separate display and operating unit FHX40. The housing of the Gammapilot M does not have to be opened to connect the FHX40.

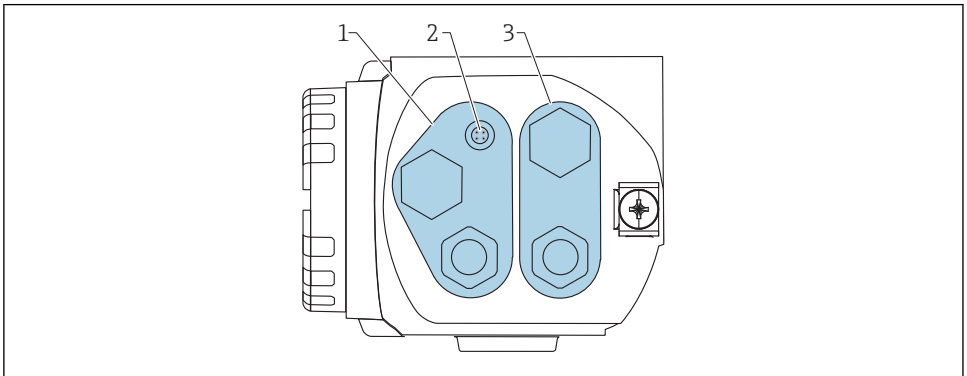

A0018083

- 1 Cable entry for connection compartment 2
- 2 Socket for FHX40
- 3 Cable entry for connection compartment 1



Cable entries

- A maximum of one cable gland is provided for each of the connection compartments upon delivery. If additional cable glands are required (e.g. for cascade mode), they must be supplied by the user.
- Connecting cables should be routed away from the housing from below to prevent moisture from penetrating the connection compartment. Otherwise, a drip loop should be provided or the Gammapilot M should be fitted with a weather protection cover.

4.3 Terminal assignment

Connection compartment 1

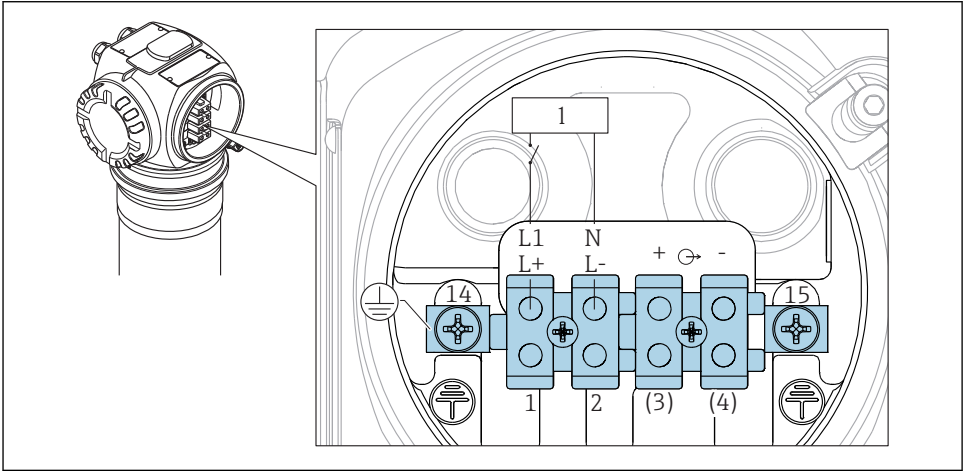

A0018084

1 For the terminal assignment, see the table below

1 Power supply: 90 to 253VAC, 18 to 35 VDC

Connection compartment 2

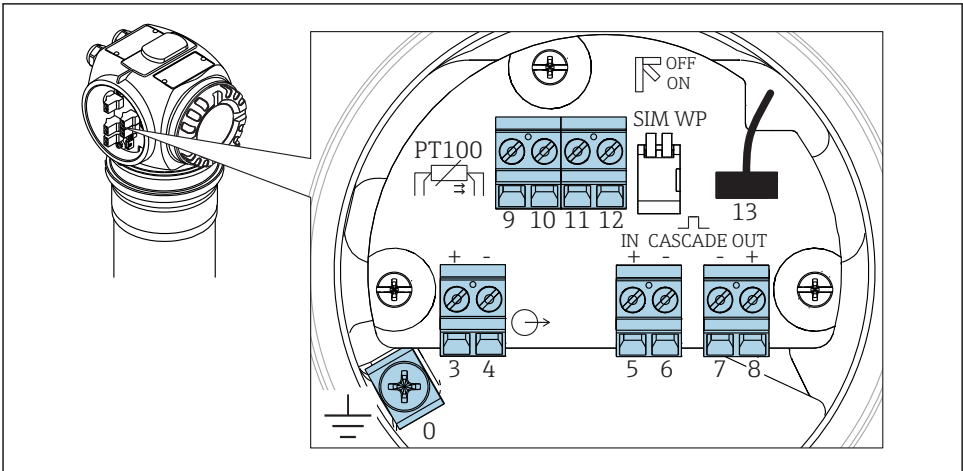

A0018085

2 For the terminal assignment, see the table below

Terminal	Meaning
0	Grounding of the cable shield ¹⁾
1, 2	Power supply ²⁾
Connection compartment 2: 3, 4 Connection compartment 1: 3 ¹⁾ , 4 ¹⁾	Signal output, depending on communication version: <ul style="list-style-type: none"> ■ 4-20mA with HART ■ PROFIBUS PA ■ FOUNDATION Fieldbus Depending on the device version ordered, the signal output is located in connection compartment 1 or 2 (see below).  For the versions of the Gammapilot M with a fieldbus connector (M12 or 7/8"), the signal output is wired in connection compartment 2 on delivery and connected to the fieldbus connector (see the "Fieldbus connectors" section). In this case, the housing does not need to be opened to connect the signal cable.
5, 6	Pulse input (for cascade mode; is used for master and slave)
7, 8	Pulse output (for cascade mode; is used for slave and end slave)
9, 10, 11, 12	Pt-100 input (4-wire)
13	Connection for display and operating module VU331 (from FHX40); is wired on delivery and connected to the FHX40 plug.
14	Protective ground ¹⁾
15	Protective ground or grounding of the cable shield ¹⁾

1) Rated cross-section > 1 mm² (17 AWG)

2) Rated cross-section max. 2.5 mm² (14 AWG)

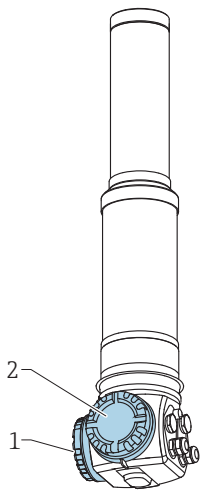

The cables used at terminals 14 and 15 must at least have the same cross-section as the cables at terminals 1 and 2.

Feature 30 of the ordering information: power supply wiring/output wiring		Connection compartment with terminals for		
		Supply voltage	Signal output	
A	Non-Ex; non-Ex	1	2	 <p>A0018082</p>
B	Ex e; Ex ia	1	2	
C	Ex e; Ex e	1	1	
D	Ex d (XP); Ex d (XP)	1	1	
E	Ex d (XP); Ex ia (IS)	1	2	
F	Dust-Ex; Dust-Ex	1	1	
G	Ex e, Dust-Ex; Ex e, Dust-Ex	1	1	
H	Ex d, Dust-Ex; Ex d, Dust-Ex	1	1	
J	Ex e, Dust-Ex; Ex ia, Dust-Ex	1	2	
K	Ex d, Dust-Ex; Ex ia, Dust-Ex	1	2	
L	Dust-Ex; Ex ia	1	2	

4.4 Potential equalization

Before wiring, connect the potential matching line to the external ground terminal of the transmitter. If a water cooling jacket is provided, it must be connected separately to the potential matching line.

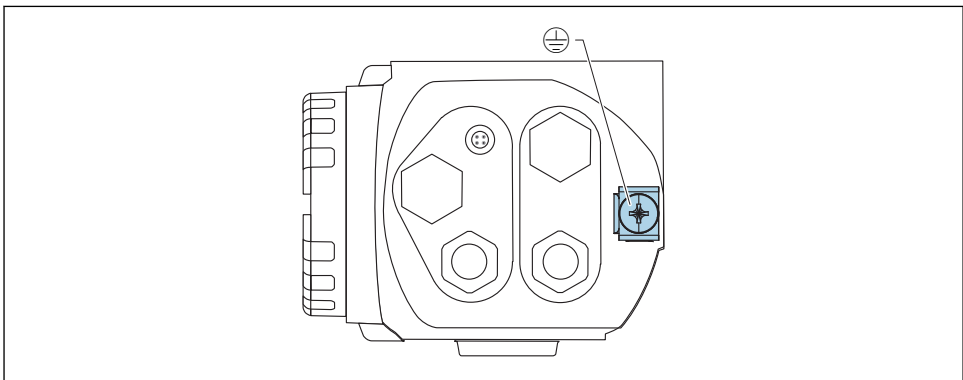

3 Ground terminal for connecting the potential matching line

⚠ CAUTION**In Ex applications, the device may only be grounded on the sensor side**

- ▶ Please refer to the separate documentation on applications in hazardous areas for further safety instructions.



For optimum electromagnetic compatibility, the potential matching line should be as short as possible and at least 2.5 mm² (14 AWG) in cross-section.

4.5 Wiring in connection compartment 1

⚠ CAUTION**Note the following before connecting:**

- ▶ If the device is used in hazardous areas, make sure to comply with national standards and the specifications in the Safety Instructions (XAs). The specified cable gland must be used.
- ▶ The supply voltage must match the specifications on the nameplate
- ▶ Switch off the supply voltage before connecting the device.
- ▶ Connect the potential matching line to the external ground terminal of the transmitter and to the ground terminal of the water cooling jacket (if present) before connecting the device. (See "Potential equalization" section)
- ▶ Connect the protective ground to the protective ground terminal (see "Terminal Assignment" section)
- ▶ According to IEC/EN 61010 a suitable circuit breaker must be provided for the device
- ▶ The cables must be adequately insulated, with due consideration given to the supply voltage and the overvoltage category.
- ▶ The connecting cables must offer adequate temperature stability, with due consideration given to the ambient temperature.

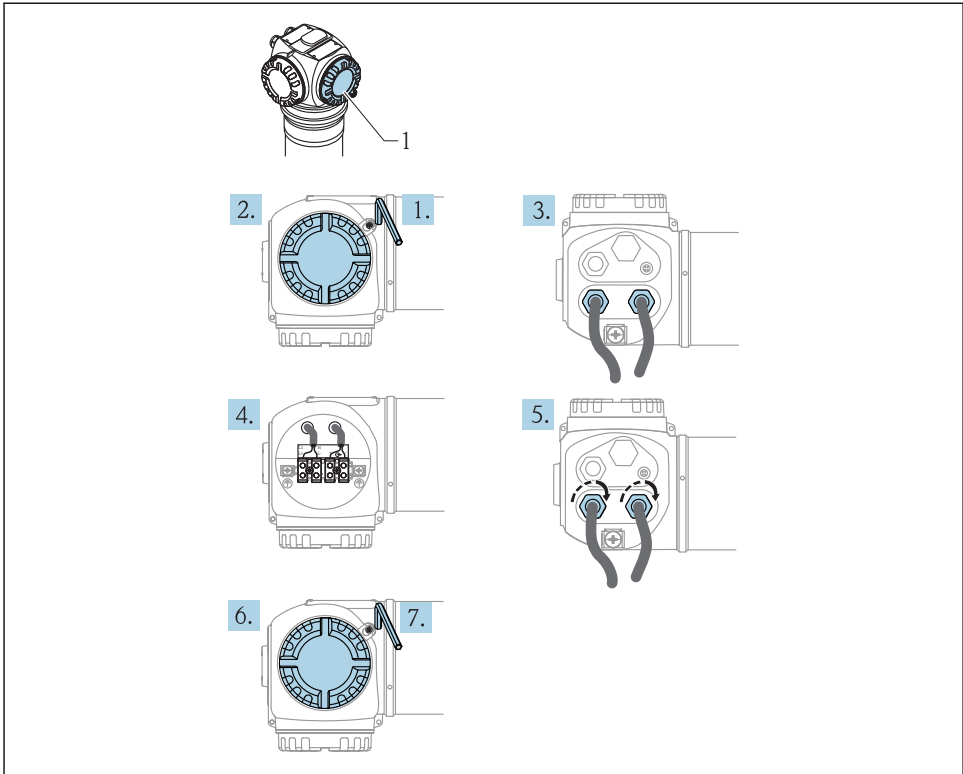

A0019826

1. Using a 3 mm Allen key, loosen the cover clamp for the connection compartment cover
2. Unscrew the cover
3. Push the power cable and (if required) the signal cable through the appropriate cable glands or cable entries
4. Wire up according to the terminal assignment diagram
5. Tighten the cable glands or cable entries so that they are leak-tight
6. Screw the cover securely back onto the connection compartment
7. Turn the cover clamp so that it is set over the cover and then tighten.

4.6 Wiring in connection compartment 2

⚠ CAUTION

Note the following before connecting:

- ▶ Connect the potential matching line to the external ground terminal of the transmitter and to the ground terminal of the water cooling jacket (if present) before connecting the device. (See "Potential equalization" section)
- ▶ The cables must be adequately insulated, with due consideration given to the supply voltage and the overvoltage category.
- ▶ The connecting cables must offer adequate temperature stability, with due consideration given to the ambient temperature.

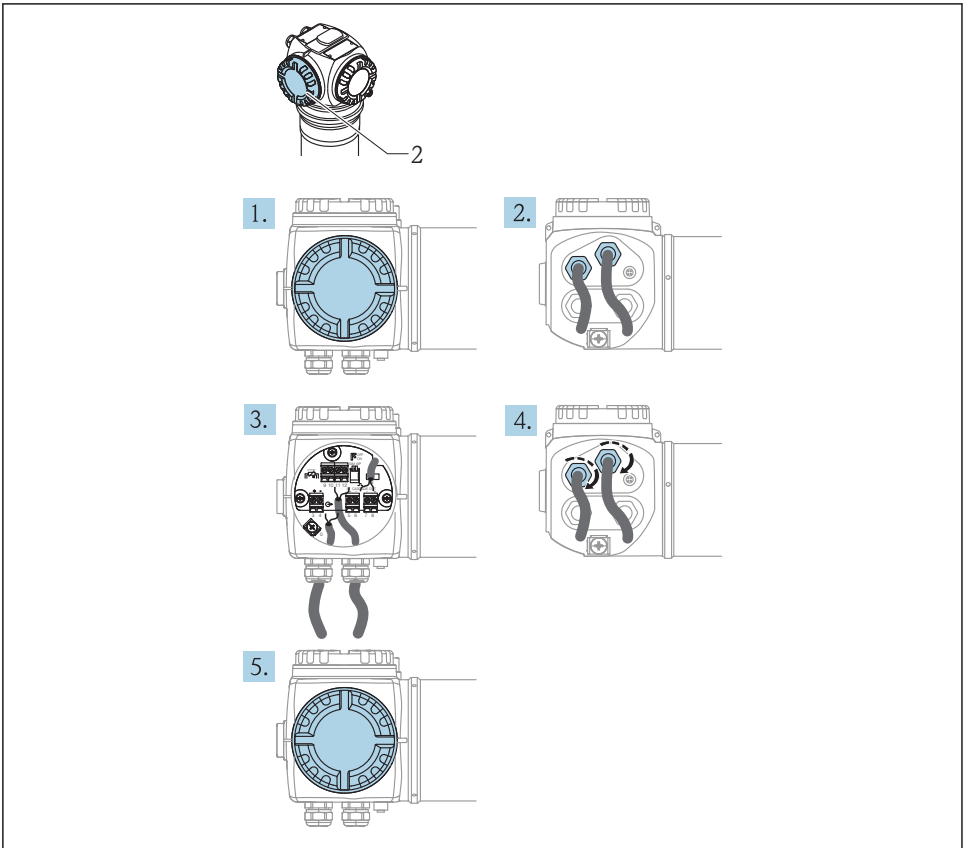

A0019827

1. Unscrew the cover

2. Push the following cables through the corresponding cable glands or cable entries: signal cable (if the signal output is located in connection compartment 2), Pt100 cable (if present), cascading cable (input and/or output, if required)
3. Wire up according to the terminal assignment diagram
4. Tighten the cable glands or cable entries so that they are leak-tight
5. Screw the cover securely back onto the connection compartment

4.7 Connecting the remote display and operating unit FHX40

The remote display and operating unit FHX40 is available as an accessory. It is connected to the FHX40 connector of the Gammapilot M via the cable supplied. The housing of the Gammapilot M does not have to be opened for this.

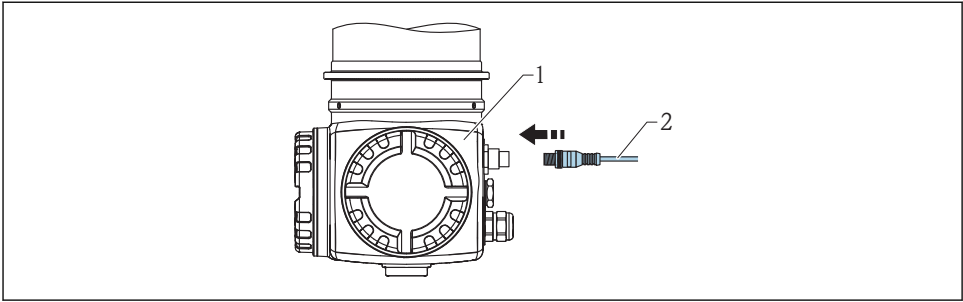

A0018089

- 1 Gammapilot M FMG60
- 2 Cable of the display and operating unit FHX40

For some Dust-Ex versions of the Gammapilot M, the FHX40 connector is protected by a metal sleeve:

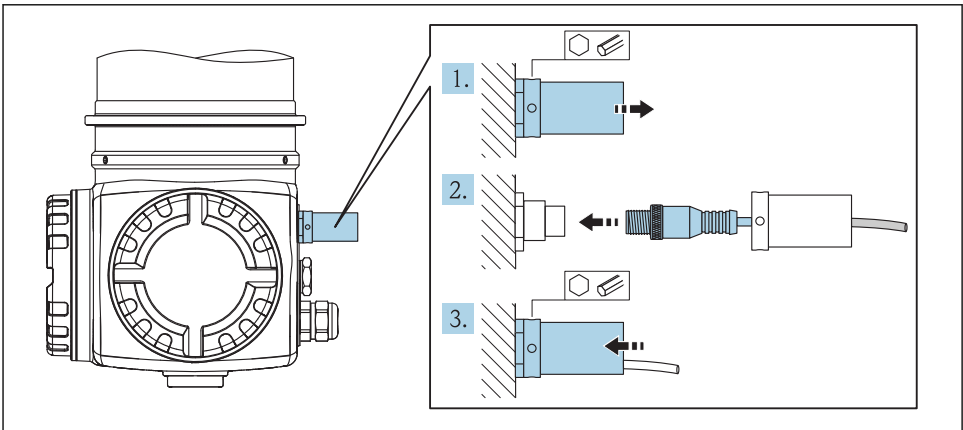

A0018090

1. Loosen the sleeve with an Allen key and remove it
2. Connect the display and operating unit FHX40
3. Attach the sleeve and fasten the Allen screw

4.8 Wiring for cascade mode

See the Operating Instructions



BA00236F/00/EN

4.9 Wiring example for point level detection 200/400 mm

The output signal is linear between the free and covered calibration (e.g. 4 to 20 mA) and can be evaluated in the control system. If a relay output is needed, the following Endress+Hauser process transmitters can be used:

- RTA421: for non-Ex applications, without WHG (German Water Resources Act), without SIL
- RMA42: for Ex applications, with SIL certificate

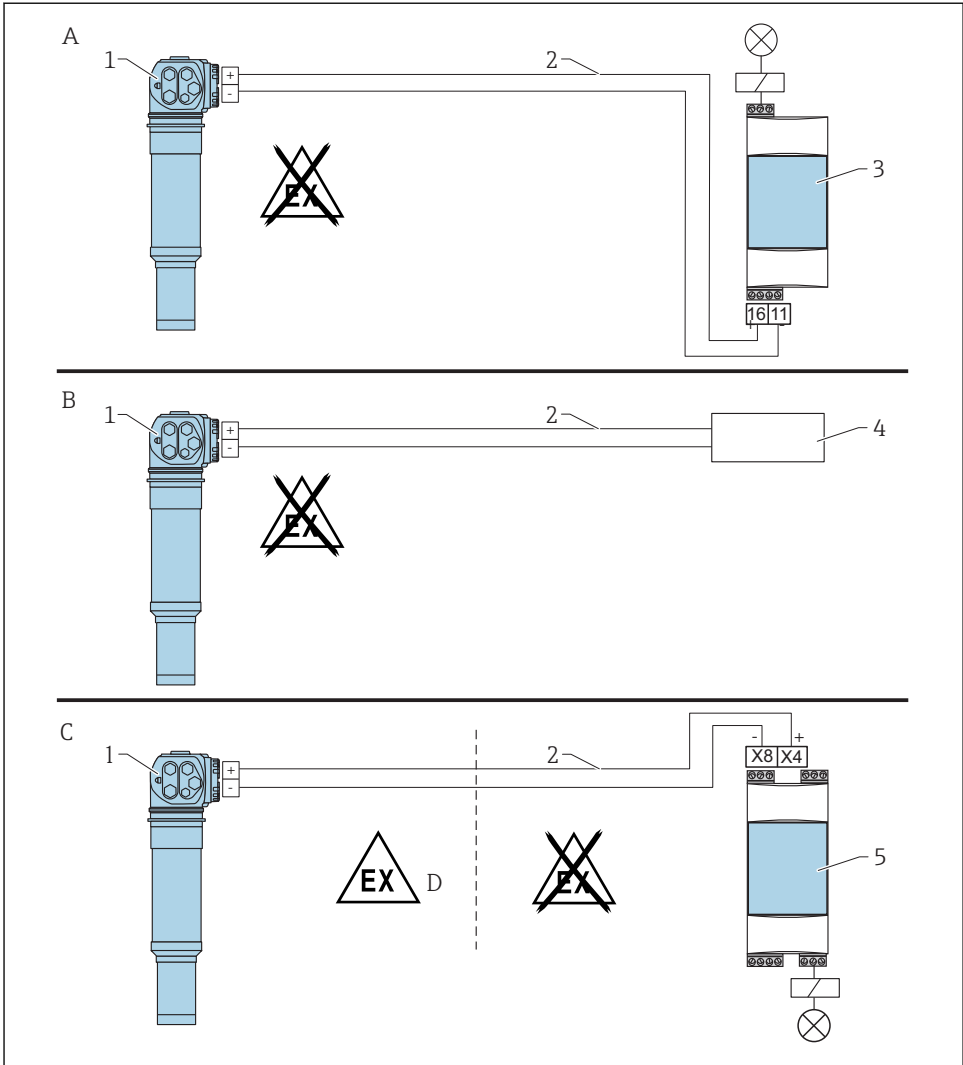

A0018092

- A Wiring with RTA421 switching unit
- B Wiring with process control system
- C Wiring with RMA42 switching unit
- D When installing in hazardous areas, please observe the corresponding Safety Instructions
- 1 Gammapilot M
- 2 4 to 20 mA
- 3 RTA421
- 4 PLC
- 5 RMA42

4.9.1 Ex applications in conjunction with RMA42

Observe the following Safety Instructions:

- XA00303F/00/A3: ATEX II 2 (1) G for Gammapilot M
- XA00304F/00/A3: ATEX II 2 (1) D for Gammapilot M
- XA00095R/09/A3: ATEX II (1) G [Ex ia] IIC, ATEX II (1) D [Ex ia] IIIC for RMA42

4.9.2 SIL applications for Gammapilot M FMG60 in conjunction with RMA42 (for point level detection 200/400 mm PVT scintillator)

- The Gammapilot M meets SIL2/3 as per IEC 61508, see:
 - Functional Safety Manual SD00230F/00/EN (maximum point level detection)
 - Functional Safety Manual SD00324F/00/EN (minimum point level detection)
- The RMA42 meets SIL2 as per IEC 61508:2010 (Edition 2.0), see the Functional Safety Manual SD00025R/09/EN

4.10 Post-connection check

After wiring the device, carry out the following checks:

- Is the protective ground connected?
- Is the potential matching line connected?
- Is the terminal assignment correct?
- Are the cable glands and dummy plugs tight?
- Are the fieldbus connectors and the FHX40 connector fixed securely?
- Are the covers screwed tightly onto the connection compartments?
- For Dust-Ex devices: is the protective sleeve for the FHX40 socket mounted correctly?
- Is the cover of connection compartment 1 secured by the cover clamp?

WARNING

- ▶ The Gammapilot M may only be operated if the cover of connection compartment 1 is closed.

5 Operation

5.1 Display operation

5.1.1 Display and operating elements

The LCD module VU331 for displaying and operating is located inside the remote display and operating unit FHX40. The measured value can be read through the FHX40 window. The FHX40 must be opened in order to operate the device. Remove the four screws on the cover to do so.

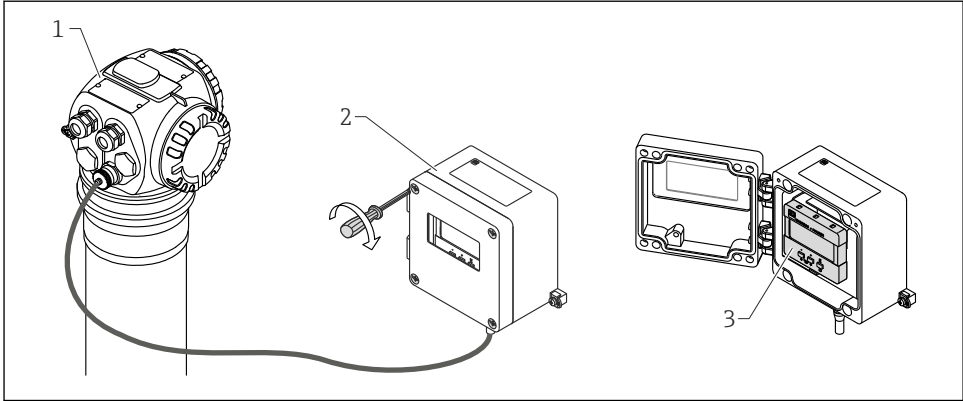

A0018096

- 1 Gammapilot M
- 2 FHX40
- 3 Operating module VU331

LCD module VU331

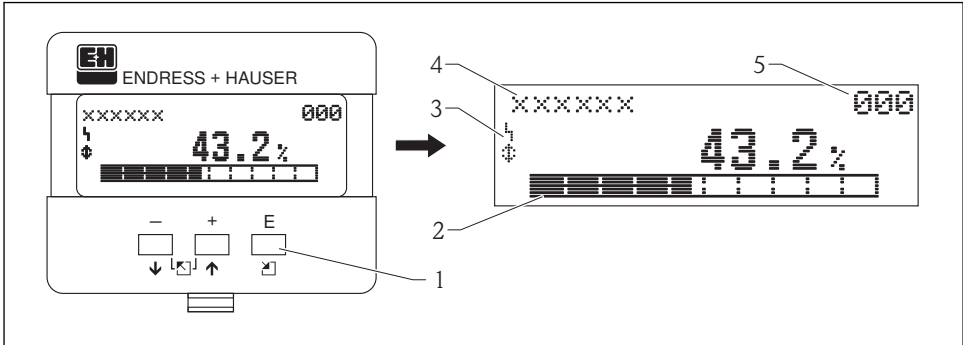





A0018097















- 1 Operating keys
- 2 Bargraph
- 3 Symbols
- 4 Function name
- 5 Parameter ID number

Display symbols

The following table describes the symbols that appear on the liquid crystal display:

Symbol	Meaning
	ALARM_SYMBOL This alarm symbol is displayed when the device is in an alarm condition. If the symbol flashes, this indicates a warning.
	LOCK_SYMBOL This lock symbol is displayed when the device is locked, i.e. if no entries are possible.
	COM_SYMBOL This communication symbol is displayed when data transmission via HART, PROFIBUS PA or FOUNDATION Fieldbus, for example, is in progress.
	SIMULATION_SWITCH_ENABLE This communication symbol is displayed when simulation in FOUNDATION Fieldbus is enabled via the DIP switch.

Key functions

Operating key(s)	Meaning
 or 	Navigate upwards in the picklist Edit the numeric values within a function
 or 	Navigate downwards in the picklist Edit the numeric values within a function
 and  or 	Navigate to the left within a function group
	Navigate to the right within a function group, confirmation
 and  or  and 	Contrast settings of the LCD
 and  and 	Hardware locking/unlocking After locking the hardware, operation via the display and communication is not possible! The hardware can only be unlocked via the display. An access code must be entered to do so.

5.1.2 The operating menu

Function codes

The functions of the Gammapilot M are arranged in an operating menu. To ensure easy orientation within this menu, a unique position code is indicated on the display for each function. This code consists of one alphabetic and two numeric characters.

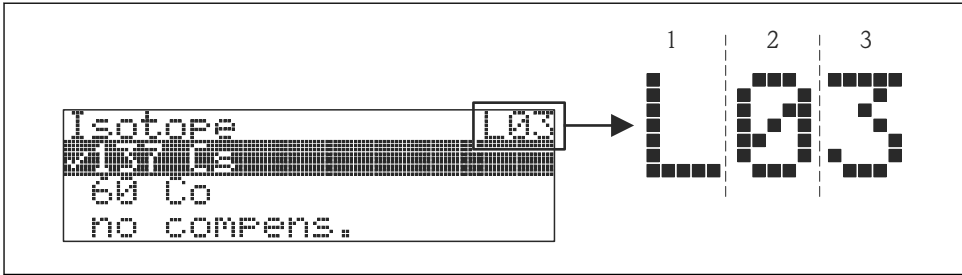

A0019876-EN

- 1 Measurement mode
- 2 Function group
- 3 Function

- The alphabetic character indicates the current measurement mode of the Gammapiot M:
 - **L**: Level
 - **S**: Switch
 - **D**: Density
 - **C**: Concentration
 - *****: no measurement mode selected yet
- The first numeric character identifies the function group:
 - **Basic setup *0**
 - **Calibration *1**
 - **Safety settings *2**
 - ...
- The second numeric character identifies the individual functions within the function group:
 - **Basic setup *0**
 - **Today's date *01**
 - **Beam type *02**
 - **Isotope *03**
 - **Operating mode *04**
 - ...

Hereinafter, the position is always indicated in brackets after the function name. "*****" (not yet selected) is always indicated as the measurement mode, e.g. "**Present date**" (***01**)

6 Commissioning



This chapter describes how to commission the Gammapiot M using the display and operating module VU331 (which is located in the remote display and operating unit FHX40). Commissioning via "FieldCare" or "Field Xpert SFX100" is performed in a similar manner. More information on the "FieldCare" operating program and on Field Xpert SFX100 is provided in BA00027S/04/EN and BA00060S/04/EN respectively.

6.1 Calibration: overview

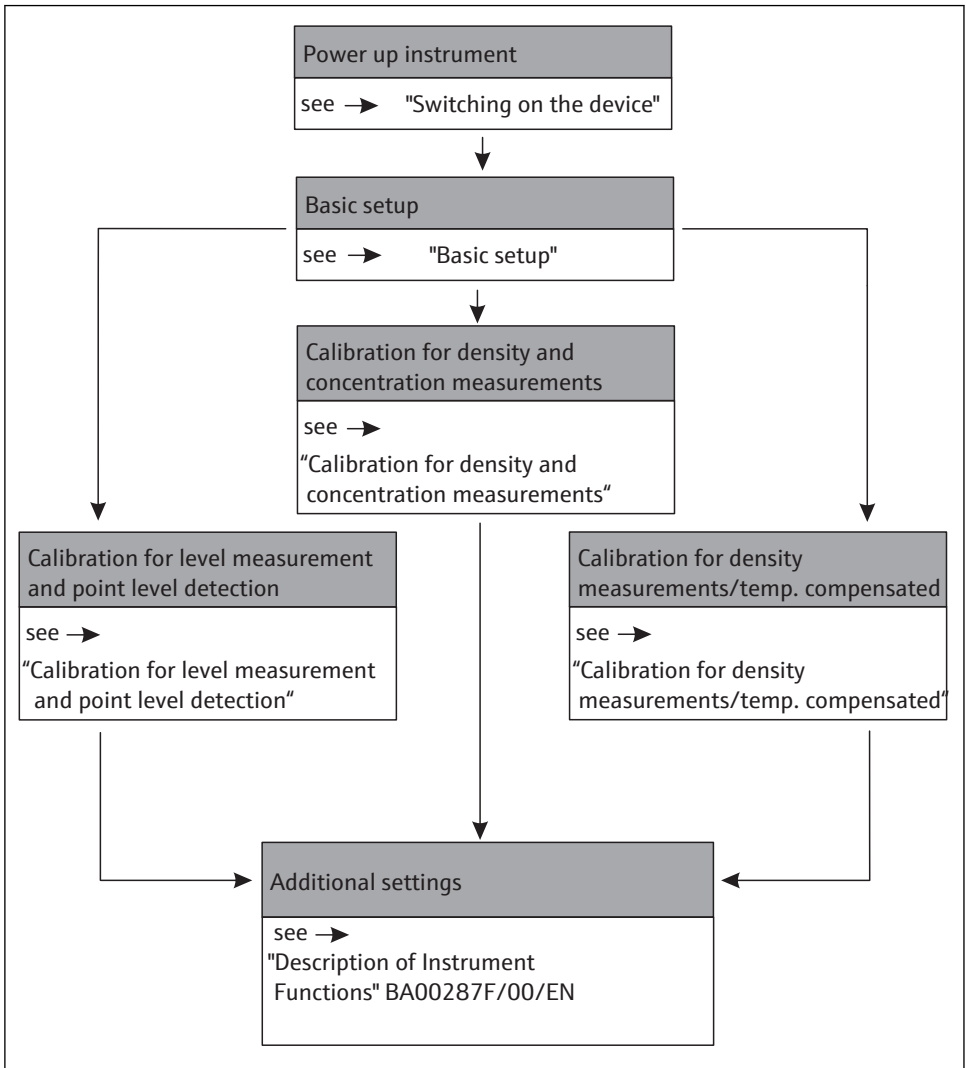

A0037160-EN



A detailed description of the functions used can be found in the following sections:

- Basic setup → 33
- Calibration for level measurement and point level detection → 39
- Calibration for density and concentration measurements → 49
- Density measurement/temperature-compensated → 58

6.2 Function check

Ensure that the post-installation check and post-connection check were carried out before the measuring point was commissioned.

- "Post-installation check" checklist (see "Post-installation check" section)
- "Post-connection check" checklist (see "Post-connection check" section)

6.3 Switching on the device



Error messages A165 "Electronics defect" and A635 "Present date not defined" The

Gammapilot M contains 2 real-time clocks for decay compensation, which are permanently compared with one another for safety reasons. In order to bridge voltage interruptions, the clocks are buffered with a capacitor. To ensure that the clocks work correctly and retain the date in the event of a voltage interruption, this capacitor must have a minimum charge. If the A165 "Electronics defect" or A635 "Present date not defined" error message appears **after switching on** the Gammapilot M, this may indicate that the capacitor is not yet sufficiently charged. In this case, the Gammapilot M must be operated at the operating voltage for at least 20 to 30 minutes in order to charge the capacitor. After this, the correct date must be entered. If the error message persists after this, it can be deleted by switching the Gammapilot M off and then on again.

After the supply voltage has been switched on, the device is first initialized. Due to internal memory tests, this takes approx. 2 minutes.

Local display

FMG60 V01.03.06

The following information appears for approximately 5 seconds:

- Device type
- Software version
- Type of communication signal

Language 092

✓ English Français Español

On the first power-up, select the language for the text on the display.

Select the language with the and keys. Press twice to confirm your selection.

Group selection

✓ Basic setup Calibration Safety settings

The measured value screen then appears.

The basic setup can now be performed. Press **[E]** to switch to the group selection:

Press **[E]** again to enter the first function of the "Basic setup" function group

6.4 Basic setup

6.4.1 "Present date" (*01)

Local display
Present date *01 17.11.04 ____ 10:30 DD.MM.YY ____ HH:MM

This function is used to enter the date and time of the basic setup. Each of these values must be confirmed by pressing **[E]** after entering the value.

6.4.2 "Beam type" (*02)

Local display
Beam type *02 ✓ Standard/cont. Modulated

This function is used to specify whether the radiation source used emits radiation continuously or whether it is modulated (for gamma radiography suppression).

- Standard/continuous (permanent, continuous radiation)
- Modulated (modulated radiation source)

6.4.3 "Isotope" (*03)

Local display
Isotope *03 ✓ 137 Cs 60 Co No compens.

This function is used to specify which isotope is used for the measurement. The Gammapilot M needs this information for decay compensation.

6.4.4 "Operating mode" (*04)

Local display
Operating mode *04
✓ Stand alone
Master
Slave

This function is used to specify in which operating mode the Gammapilot M will be used.

i The operating mode can only be selected once. After this, the function is automatically locked and can only be unlocked by resetting the Gammapilot M ("Reset" (*A3) function).

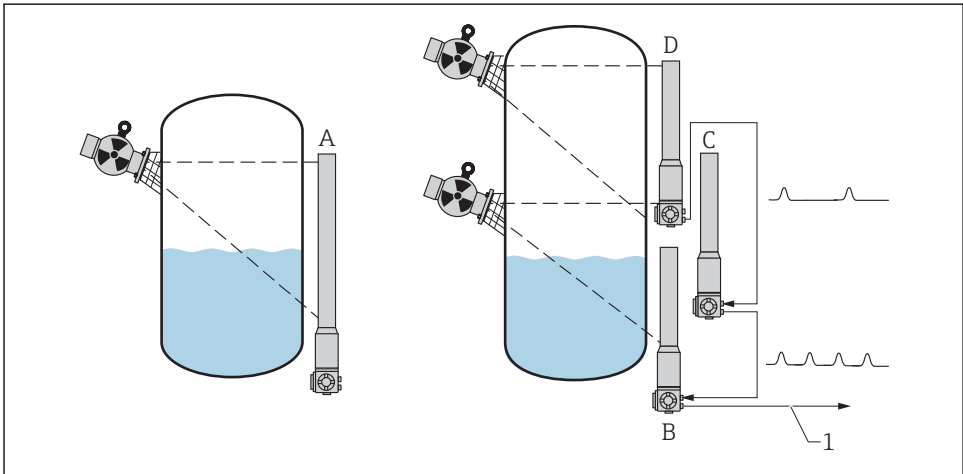

A0018107

- A Stand alone.
Only one Gammapilot M is required for measuring ranges up to 2 m (6.6 ft)
For larger measuring ranges, any number of Gammapilot M devices can be interconnected (cascade mode). The devices are defined by software settings as:
- B Master
C Slave(s) or
D End slave
- 1 4 to 20 mA HART; PROFIBUS PA; FOUNDATION Fieldbus

Options/display:

- **Stand alone:** This option is selected if the Gammapilot M is used as a single, standalone device.
- **Master:** This option is selected if the Gammapilot M is located at the beginning of a cascade chain. It then receives the pulses from a connected slave, adds its own pulses and calculates the measured value from this total.
- **Slave:** This option is selected if the Gammapilot M is located in the middle of a cascade chain. It then receives the pulses from another connected slave or end slave, adds its own pulses and transmits this total to the next device (master or slave). The calibration is finished if this option is selected. If several transmitters are cascaded, the rest of the calibration procedure is performed on the master only.
- **End slave:** This option is selected if the Gammapilot is located at the end of a cascade chain. It does not receive pulses from another device but transmits its own pulses to the next device (master or slave). The calibration is finished if this option is selected. If several transmitters are cascaded, the rest of the calibration procedure is performed on the master only.
- **Not defined:** Is displayed if the operating mode has not yet been selected. An option must be selected in order to continue with the basic setup.



If a "slave" or an "end slave" is connected to "FieldCare", the pulse rate of this device is displayed in the header instead of the measured value.

6.4.5 "Measurement mode" (*05)

Local display
Measurement mode *05
✓ Level
Switch
Density

This function is used to select the desired measurement mode.

Further options:

- Level measurement (continuous)
- Point level detection
- Density measurement (with temperature compensation if required)
- Concentration measurement (density measurement followed by linearization)



The operating mode can only be selected once. After this, the function is automatically locked and can only be unlocked by resetting the Gammapilot M ("Reset" (*A3) function).

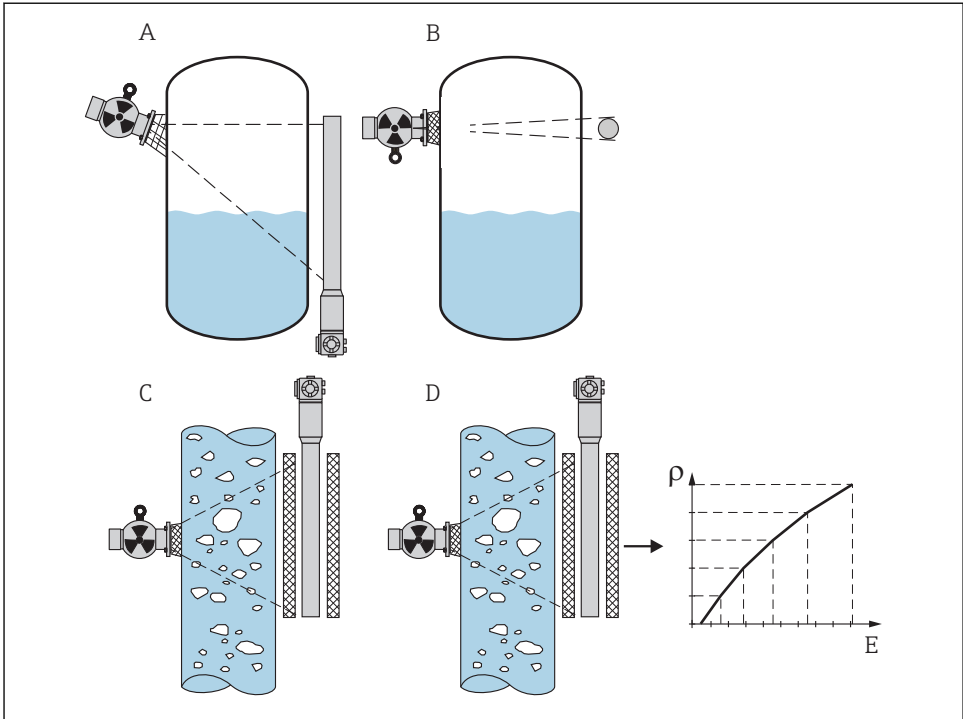

A0018108

A Level measurement (continuous)

B Point level detection

C Density measurement (with temperature compensation if required)

D Concentration measurement (density measurement followed by linearization)

ρ Density

E Concentration

6.4.6 "Density unit" (*06)

Local display

Density unit *06

✓ g/cm³

g/l

lb/gal

This function is needed for density and concentration measurements only. It is used to select the density unit.

Further options:

- g/cm^3
- g/l
- lb/gal ; [$1\text{g/cm}^3 = 8.345\text{ lb/gal}$]
- lb/ft^3 ; [$1\text{g/cm}^3 = 62.428\text{ lb/ft}^3$]
- °Brix; [$1^\circ\text{Brix} = 270 (1 - 1/x)$]
- °Baumé; [$1^\circ\text{Baumé} = 144.3 (1 - 1/x)$]
- °API; [$1^\circ\text{API} = 131.5 (1.076/x - 1)$]
- °Twaddell; [$1^\circ\text{Twaddell} = 200 (x-1)$]

"x" refers to the density in g/cm^3 . The formula indicates how many degrees this density corresponds to.

6.4.7 "Min. density" (*07)

Local display
Min. density *07 0.9500 g/cm^3

This function is needed for density and concentration measurements only. It is used to specify the lower limit of the density measuring range. The output current for this density is 4 mA.

6.4.8 "Max. density" (*08)

Local display
Max. density *08 1.2500 g/cm^3

This function is needed for density and concentration measurements only. It is used to specify the upper limit of the density measuring range. The output current for this density is 20 mA.

6.4.9 "Pipe diameter unit" (*09)

Local display
Pipe diam. unit *09 ✓ mm inch

This function is needed for density and concentration measurements only. It is used to select the unit for the pipe diameter.

1 in = 25.4 mm

6.4.10 "Pipe diameter" (*0A)

Local display
Pipe diam. *0A 200 mm

This function is needed for density and concentration measurements only. It is used to specify the irradiated measuring path L . With standard installation, this value is identical to the pipe inner diameter D_i . However, in the case of other installation variants (to extend the irradiated measuring path), this value may be greater (see diagram). The pipe walls are not to be considered a part of the measuring path.

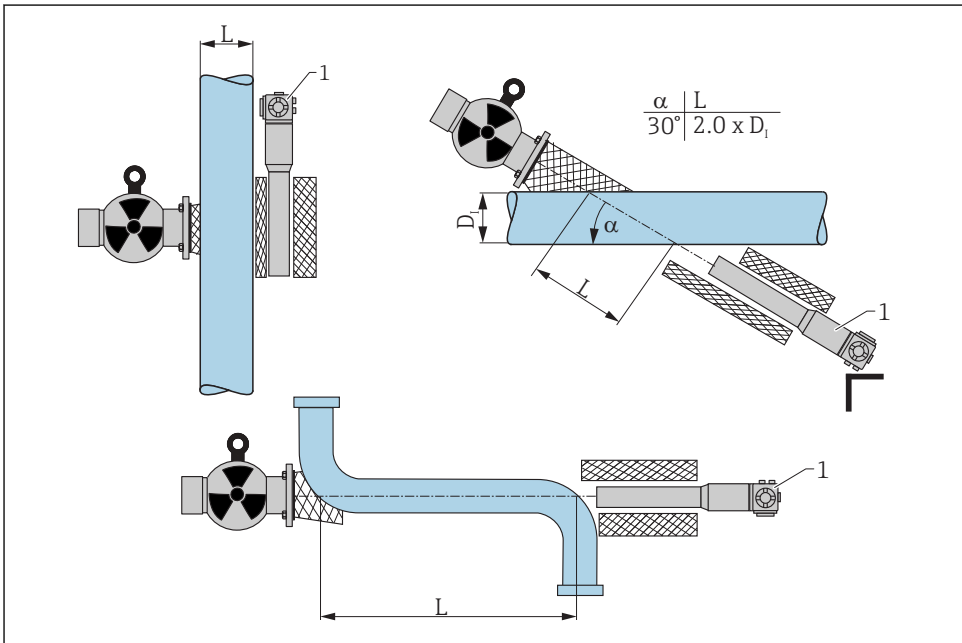

- 4 Always specify the complete irradiated measuring path L in the "Pipe diameter" (*0A) function. Depending on the installation, this value may be larger than the actual pipe diameter.

1 Gammapilot M

6.4.11 "Output damping" (*0B)

Local display
Output damping *0B 60 s

This function is used to specify the output damping time τ (in seconds). A change in the measured value is attenuated by this time. After a change in the level or density it takes $5 \times \tau$ until the new measured value is reached.

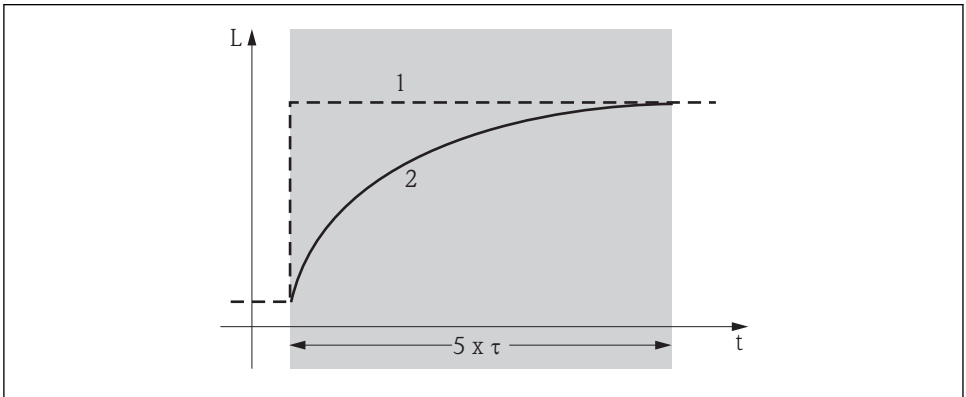

A0018110

- 1 Level change (or density change)
- 2 Measured value

Value range

1 to 999 s

Default value

The default value depends on the selected **"Measurement mode" (*05)**:

- Level: 6 s
- Switch: 6 s
- Density: 60 s
- Concentration: 60 s

Selecting the output damping value

The output damping value depends on the process conditions. Increasing the output damping value makes the measured value considerably steadier but also slower. In order to reduce the influence of stirrers or turbulent surfaces, it is advisable to increase the output damping value. However, the value selected for output damping should not be too large so that rapid changes in the measured value can also be detected quickly.

6.5 Calibration for level measurement and point level detection

6.5.1 General principles

The calibration points for the measurement are entered in the **"Calibration" (*1)** function group. Each calibration point consists of a level and the associated pulse rate.

Calibration points for level measurement

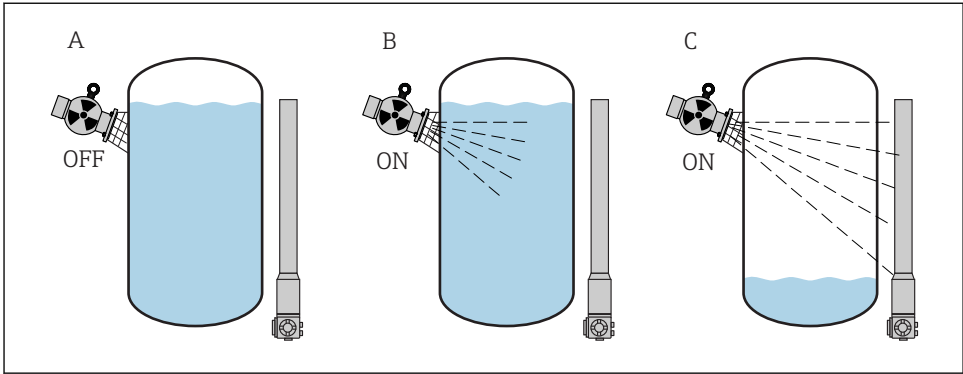

A0018111

- A Background calibration
- B Full calibration
- C Empty calibration

Background calibration

Free calibration refers to the following situation:

- The radiation is switched off
- The vessel is filled as much as possible (ideally 100%) within the measuring range

The background calibration is necessary in order to register the natural background radiation at the mounting position of the Gammapilot M. The pulse rate of this background radiation is automatically subtracted from all other measured pulse rates. This means that only the part of the pulse rate which originates from the applied radiation source is displayed and taken into account during signal analysis. As the background radiation remains virtually constant for the entire measurement duration (as opposed to the radiation of the source used), background calibration is not included in automatic decay compensation of the Gammapilot M.

Full calibration

Free calibration refers to the following situation:

- The radiation is switched on
- The vessel is filled as much as possible (ideally 100%, at least 60%) within the measuring range.

If the vessel cannot be filled to at least 60% during the calibration, the full calibration can alternatively be performed with the radiation switched off. This is a way of simulating a vessel that is 100% full. In this case, full calibration is identical to background calibration. As the pulse rate of the background calibration is automatically subtracted, the pulse rate displayed is around 0 cps.



This type of simulated calibration is not possible with self-radiating media. In this case, the vessel must be filled to 100% to perform the background and full calibration.

Empty calibration

Free calibration refers to the following situation:

- The radiation is switched on
- The vessel is emptied as much as possible (ideally 0%, at least 40%) within the measuring range.

Calibration points for point level detection

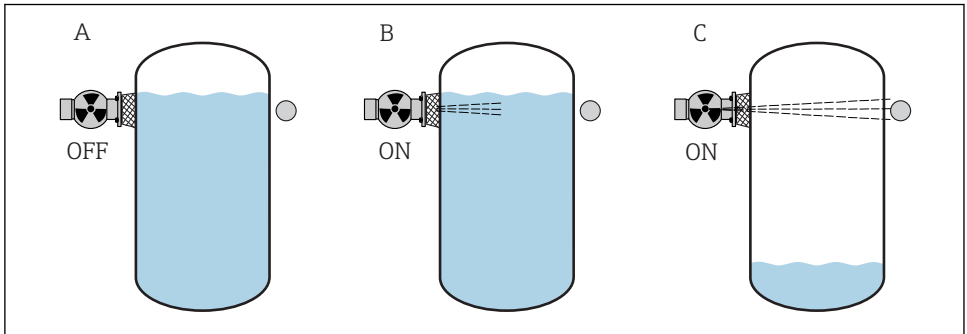

A0018112

- A Background calibration
 B Covered calibration
 C Free calibration

Background calibration

Free calibration refers to the following situation:

- The radiation is switched off.
- The radiation path is completely covered

The background calibration is necessary in order to register the natural background radiation at the mounting position of the Gammapilot M. The pulse rate of this background radiation is automatically subtracted from all other measured pulse rates. This means that only the part of the pulse rate which originates from the applied radiation source is displayed. As the background radiation remains virtually constant for the entire measurement duration (as opposed to the radiation of the source used), background calibration is not included in automatic decay compensation of the Gammapilot M.

Covered calibration

Free calibration refers to the following situation:

- The radiation is switched on
- The radiation path is completely covered, where possible

If the radiation path cannot be completely covered during the calibration, the covered calibration can alternatively be performed with the radiation switched off. This is a way of simulating a completely covered radiation path. In this case, covered calibration is identical to

background calibration. As the pulse rate of the background calibration is automatically subtracted, the pulse rate displayed is around 0 c/s.

 This type of simulated calibration is not possible with self-radiating media. In this case, the radiation path must be completely covered to perform the background calibration and the covered calibration.

Free calibration

Free calibration refers to the following situation:

- The radiation is switched on
- The radiation path is completely free

Methods for entering the calibration points

Automatic calibration

For an automatic calibration, the vessel is filled to the required value. The radiation remains switched off for background calibration, while radiation is switched on for all other calibration points. The Gammapilot M records the pulse rate automatically. The associated level is entered by the user.

Manual calibration

If one or more calibration points cannot be implemented during the commissioning of the Gammapilot M (e.g. because the vessel cannot be sufficiently filled or emptied), this calibration point must be entered manually. This means that both the level and the associated pulse rate must be entered directly. Please contact Endress+Hauser Service for any questions regarding the calculation of the pulse rate.

 Calibration date and calibration

- The calibration date is not set automatically during manual calibration. It must be entered by the user in the "**Calibration date**" (*C7) function.
- A calibration point entered manually should be replaced by an automatic calibration as soon as the associated level occurs during the operation of the plant. This recalibration is advisable because calibration points entered automatically result in more precise measurement results than calculated ones.

6.5.2 Background calibration

Excerpt from the operating menu

The following excerpt from the operating menu illustrates the entries to be made for background calibration. The individual functions are explained in detail in the sections that follow.

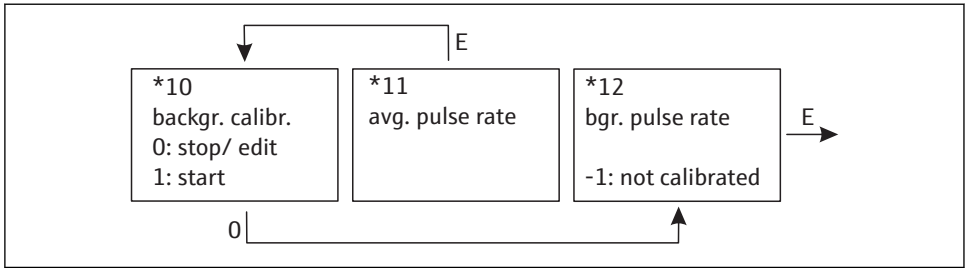

A0037161-EN

"Background calibration" (*10)

Local display
Backgr. cal. *10 Stop/edit Start

This function is used to start the background calibration

Options:

■ Stop/edit

This option must be selected if:

- No background calibration is to be performed but the pulse rate of an existing background calibration is to be displayed instead.
- The background calibration is to be performed manually.

Once this option has been selected, the Gammapilot M goes to the **"Bgr. pulse rate" (*12)** function where the existing pulse rate is displayed and can be changed if required.

■ Start

This option is used to start automatic background calibration. The Gammapilot M changes to the **"Avg. pulse rate" (*11)** function

"Avg. pulse rate" (*11)

Local display
Avg. pulse rate *11 186 cps

The average (integrated) pulse rate is displayed in this function (after the selection of "Start" in the previous function). Initially, this value fluctuates (because of the decay statistics), but reaches an average value over time due to integration. The longer the averaging is performed, the lower the fluctuations.

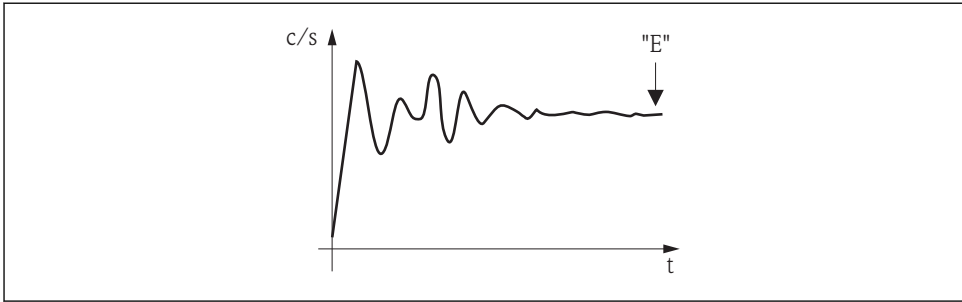

A0018118

When the value is sufficiently stable users can quit the function by pressing \boxed{E} . After this, the Gammapilot M changes to the **"Background calibration" (*10)** function. Here the **"Stop/edit"** option must be selected to stop the integration. The value is then automatically transmitted to the **"Background pulse rate" (*12)** function.



Background pulse rate

- The maximum integration time (= averaging time) is 1000 s. After this time, the value is automatically transmitted to the **"Background pulse rate" (*1B)** function.
- Integration is **not** terminated by pressing \boxed{E} in the **"Avg. pulse rate" (*11)** function. Integration continues until **"Stop/edit"** is selected in the **"Background calibration" (*10)** function. For this reason, there may be a slight deviation between the last average (integrated) pulse rate displayed and the final **"Background pulse rate" (*12)**.

"Background pulse rate" (*12)

Local display
Backgr. pulse rate *12 186 cps

The pulse rate of the background calibration is displayed in this function. Press \boxed{E} to confirm the value and complete the background calibration. If a background calibration has not yet been performed, "-1" is displayed. There are two options if this occurs:

- Return to the "Background calibration" (*10) function and restart the background calibration
- Enter a known or calculated pulse rate (manual calibration). The Gammapilot M then changes to the "Calibration point" (*13) or (*1A) function.

6.5.3 Full and empty calibration or covered and free calibration

Excerpt from the operating menu

The following excerpt from the operating menu illustrates the procedure for empty and full calibration (for level measurements) or for free and covered calibration (for point level detection). The individual functions are explained in detail in the sections that follow. The functions are only accessible once the background calibration has been performed.

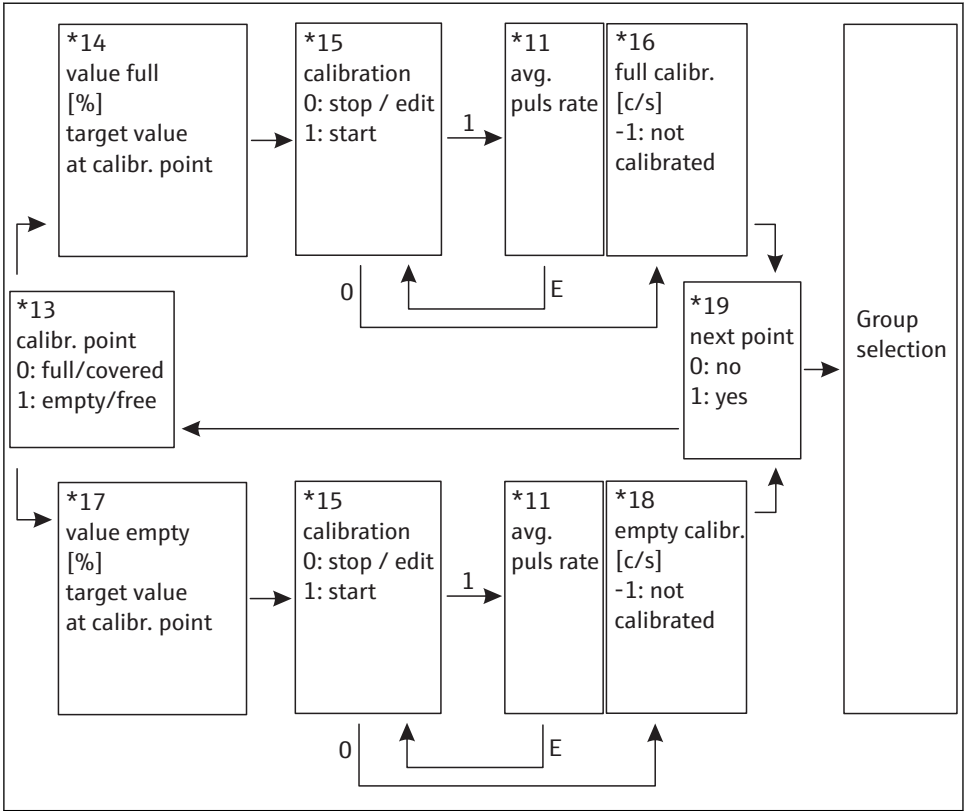

A0037162-EN

 The "Value full" (*14) and "Value empty" (*17) functions only appear if the "Level" option was selected in the "Measurement mode" (*05) function.

"Calibration point" (*13)

Local display
Calibr. point *13
✓ Full/covered
Empty/free

This function is used to select which calibration point ("full/covered" or "empty/free") will be entered.

"Value full" (*14) / "Value empty" (*17)

Local display
Value full *14 100%

Local display
Value empty *17 0%

These functions are needed for level measurements only. They are used to specify the level at which the full or empty calibration is performed.

Value range

	optimum value	minimum value	maximum value
Value full (*14)	100%	60%	100%
Value empty (*17)	0%	0%	40%

"Calibration" (*15)

Local display
Calibration *15 Stop/edit Start

This function is used to start automatic entry of the selected calibration point

Options:

- **Stop/edit**

This option must be selected if:

- The calibration point is not to be entered (e.g. because it has already been entered). The pulse rate of the calibration point is then displayed in the following function **"Full calibration" (*16)** or **"Empty calibration" (*18)**. This value can be changed if required.
- The calibration point is to be entered manually. The Gammapilot M changes to the **"Full calibration" (*16)** or **"Empty calibration" (*18)** function.

- **Start**

This option is used to start automatic entry of the calibration point. The Gammapilot M then changes to the **"Avg. pulse rate" (*11)** function.

"Avg. pulse rate" (*11)

Local display
Avg. pulse rate *11 2548 cps

The average (integrated) pulse rate is displayed in this function (after the selection of "Start" in the previous function). Initially, this value fluctuates (because of the decay statistics), but reaches an average value over time due to integration. The longer the averaging is performed, the lower the fluctuations.

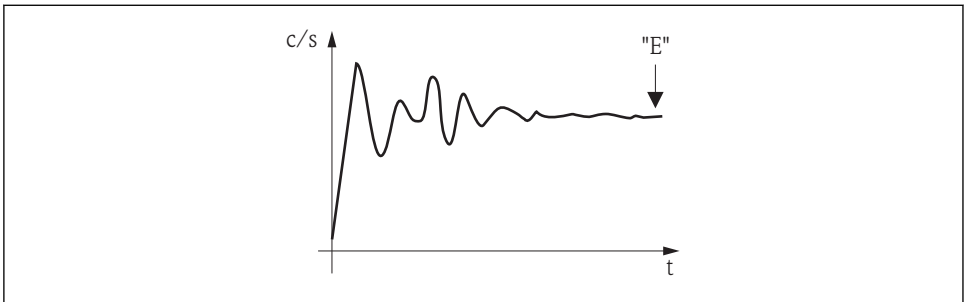

A0018118

- 5 *The integrated (average) pulse rate fluctuates greatly at the start. An average value is reached over time.*

When the value is sufficiently stable users can quit the function by pressing \square . After this, the Gammapilot M changes to the "Calibration" (*15) function. Here the "Stop/edit" option must be selected to stop the integration. The value is then automatically transmitted to the "Full calibration" (*16) or "Empty calibration" (*18) function.

**Avg. pulse rate**

- The maximum integration time (= averaging time) is 1000 s. After this time, the value is automatically transmitted to the "Full calibration" (*16) or "Empty calibration" (*18) function.
- Integration is **not** terminated by pressing \square in the "Avg. pulse rate" (*11) function. Integration continues until "Stop/edit" is selected in the "Calibration" (*15) function. For this reason, there may be a slight deviation between the last average (integrated) pulse rate displayed and the final "Full calibration" (*16) or "Empty calibration" (*18).

"Full calibration" (*16) / "Empty calibration" (*18)

Local display
Full calibration *16 33 cps

Local display
Empty calibration *18 2548 cps

The pulse rate of the full or empty calibration is displayed in this function. Press **[E]** to confirm the value. If a full or empty calibration has not yet been performed, "-1" is displayed. There are two options if this occurs:

- Either return to the "Calibration" (*15) function and restart the calibration
- Or enter a known or calculated pulse rate (manual calibration)

"Next point" (*19)

Local display
Next point *19 ✓ No Yes

This function is used to specify whether an additional calibration point is to be entered or not.

Options:

- **No**
Select this option once both calibration points have been entered. The Gammapilot M then returns to the group selection and the calibration is completed.
- **Yes**
Select this option if only one calibration point has yet been entered. The Gammapilot M then returns to the **"Calibration point" (*13)** function and the next point can be entered.

6.5.4 Additional settings

After the basic setup, the Gammapilot M outputs the measured value via the current output and the HART signal. The entire measuring range (0 to 100%) is mapped to the range (4 to 20 mA) of the current output. Many additional functions are available for optimizing the measuring point and can be configured as required. For a detailed description of all the device functions, see BA00287F/00/EN, "Gammapilot M - Description of Device Functions", or the CD-ROM supplied.

6.5.5 Configuration of the connected limit switch (for point level detection)

 For safety-related applications, the threshold values in the Safety Manual SD00230F/00/EN and SD00324F/00/EN must be observed.

The switching signal is calculated from the continuous signal in a connected evaluation unit or in a process transmitter and not in the Gammapilot M itself. For information on the configuration, please refer to the Operating Instructions of the specific device. The following settings are recommended if using the Endress+Hauser process transmitter RTA42.1 or RMA42:

For maximum fail-safe mode

- Switch threshold (SETPT) = 75%
- Hysteresis (HYST) = 50%

6.6 Calibration for density and concentration measurements

6.6.1 General principles

The calibration points for the measurement are entered in the "Calibration" (*1) function group. Each calibration point consists of a density value and the associated pulse rate.

Calibration points for density and concentration measurements

Function of the calibration points

In addition to the length of the irradiated measuring path, the Gammapilot M also needs the following two parameters for density and concentration measurements:

- The absorption coefficient μ of the material measured
- The reference pulse rate I_0 ²⁾

It calculates these parameters automatically from the pulse rates of the following calibration points:

- Background calibration (calibration with radiation switched off)
- Up to nine calibration points for samples of various known densities

i In the case of self-radiating media, the background calibration must always be performed when the pipe is filled. A simulated calibration with an empty pipe is not possible in this case.

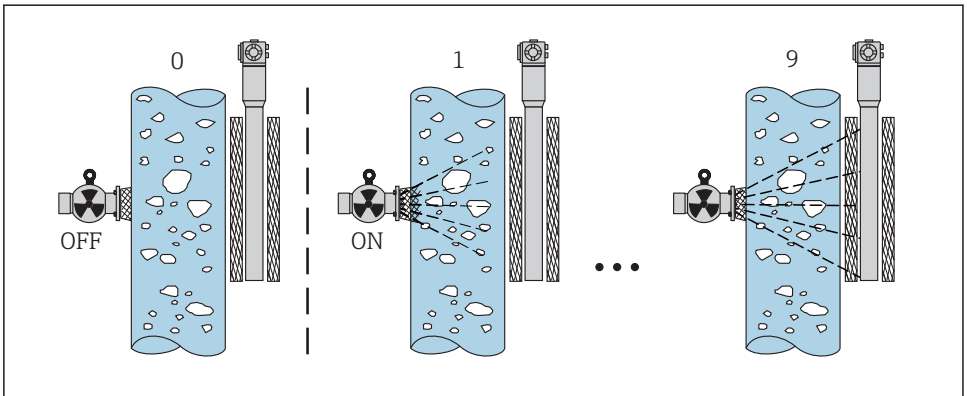

A0018128

- 0 Background calibration
- 1-9 Calibration points for various densities

2) I_0 is the pulse rate when the tube is empty. The value is significantly higher than any real pulse rates occurring during the measurement.

Two-point calibration

Two-point calibration is the calibration procedure recommended for strict accuracy requirements over the entire measuring range. Background calibration is performed first of all. Afterwards, the two calibration points are entered. These points should be as far apart as possible. Once the two calibration points have been entered, the Gammapiilot M calculates the I_0 and μ parameters on its own.

One-point calibration

A one-point calibration can be performed if a two-point calibration is not possible. This means that apart from the background calibration only one additional calibration point is used. This calibration point should be as close as possible to the operating point. Densities in the proximity of this calibration point are measured quite accurately, but the accuracy can decrease as the distance from the calibration point increases. In one-point calibration, the Gammapiilot M only calculates the reference pulse rate I_0 . In this case, it uses the default value $\mu = 7.7 \text{ mm}^2/\text{g}$ for the absorption coefficient.

Multiple-point calibration

Multiple-point calibration is recommended particularly for measurements in a large density range or for particularly accurate measurements. Up to 9 calibration points can be used over the entire measuring range. The calibration points should be as far apart as possible and should be evenly distributed over the entire measuring range. Once the calibration points have been entered, the Gammapiilot M calculates the I_0 and μ parameters on its own. Multiple-point calibration is recommended particularly for measurements in a large density range or for particularly accurate measurements.

Recalibration

The Gammapiilot M provides an additional calibration point (calibration point "10") for recalibration. This point can be entered if the measuring conditions have changed, e.g. as a result of deposit buildup in the measuring tube. Once the calibration point has been entered, I_0 is recalculated according to the current measuring conditions. The absorption coefficient μ from the original calibration remains unchanged.

Methods for entering the calibration points

Automatic calibration

In the case of automatic calibration, the calibration point in question is implemented on the vessel or the measuring tube, i.e. the measuring tube is filled with a medium of the desired density. The radiation remains switched off for background calibration, while radiation is switched on for all other calibration points. The Gammapiilot M records the pulse rate automatically. The associated density is determined in the laboratory and entered by the user.

Manual calibration

In order to achieve a high level of measuring accuracy, it is advisable to determine the pulse rates for several samples at a constant density and to calculate the average density and average pulse rate for these samples. These values can then be entered manually in the

Gammapilot M. If possible, this procedure should be repeated at another density. The two density values should be as far apart as possible.



The calibration date is not set automatically during manual calibration. It must be entered by the user in the "Calibration date" (*C7) function.

6.6.2 Background calibration

Excerpt from the operating menu

The following excerpt from the operating menu illustrates the entries to be made for background calibration. The individual functions are explained in detail in the sections that follow.

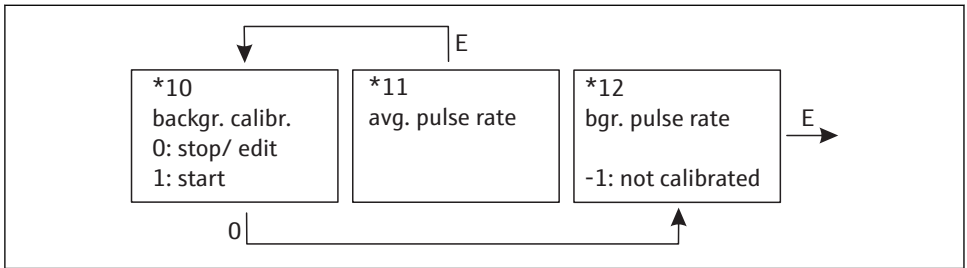

A0037161-EN

"Background calibration" (*10)

Local display
Backgr. cal. *10 Stop/edit Start

This function is used to start the background calibration

Options:

■ Stop/edit

This option must be selected if:

- No background calibration is to be performed but the pulse rate of an existing background calibration is to be displayed instead.
- The background calibration is to be performed manually.

Once this option has been selected, the Gammapilot M goes to the **"Bgr. pulse rate" (*12)** function where the existing pulse rate is displayed and can be changed if required.

■ Start

This option is used to start automatic background calibration. The Gammapilot M changes to the **"Avg. pulse rate" (*11)** function

"Avg. pulse rate" (*11)

Local display
Avg. pulse rate *11 186 cps

The average pulse rate is displayed in this function. Initially, this value fluctuates (because of the decay statistics), but reaches an average value over time due to integration. The longer the averaging is performed, the lower the fluctuations.

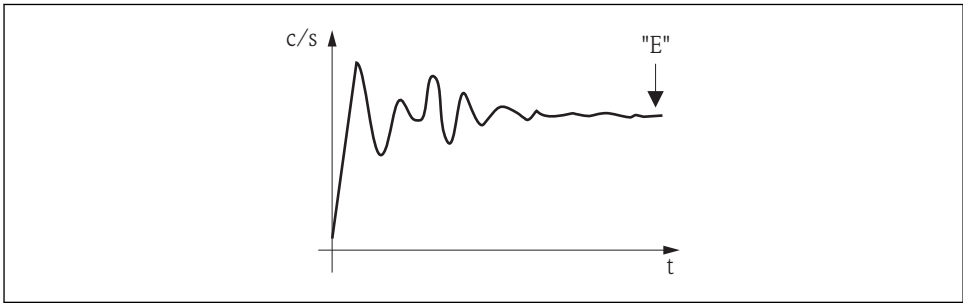

A0018118

When the value is sufficiently stable users can quit the function by pressing \boxed{E} . After this, the Gammapilot M changes to the **"Background calibration" (*10)** function. Here the **"Stop/edit"** option must be selected to stop the integration. The value is then automatically transmitted to the **"Background pulse rate" (*12)** function.

**Background pulse rate**

- The maximum integration time (= averaging time) is 1000 s. After this time, the value is automatically transmitted to the **"Background pulse rate" (*1B)** function.
- Integration is **not** terminated by pressing \boxed{E} in the **"Avg. pulse rate" (*11)** function. Integration continues until **"Stop/edit"** is selected in the **"Background calibration" (*10)** function. For this reason, there may be a slight deviation between the last average (integrated) pulse rate displayed and the final **"Background pulse rate" (*12)**.

"Background pulse rate" (*12)

Local display
Backgr. pulse rate *12 186 cps

The pulse rate of the background calibration is displayed in this function. Press \boxed{E} to confirm the value and complete the background calibration. If a background calibration has not yet been performed, "-1" is displayed. There are two options if this occurs:

- Return to the "Background calibration" (*10) function and restart the background calibration
- Enter a known or calculated pulse rate (manual calibration). The Gammapilot M then changes to the "Calibration point" (*13) or (*1A) function.

6.6.3 Calibration points

The following excerpt from the operating menu illustrates the procedure for entering the density calibration points. The individual functions are explained in detail in the sections that follow. The functions are only accessible once the background calibration has been performed.

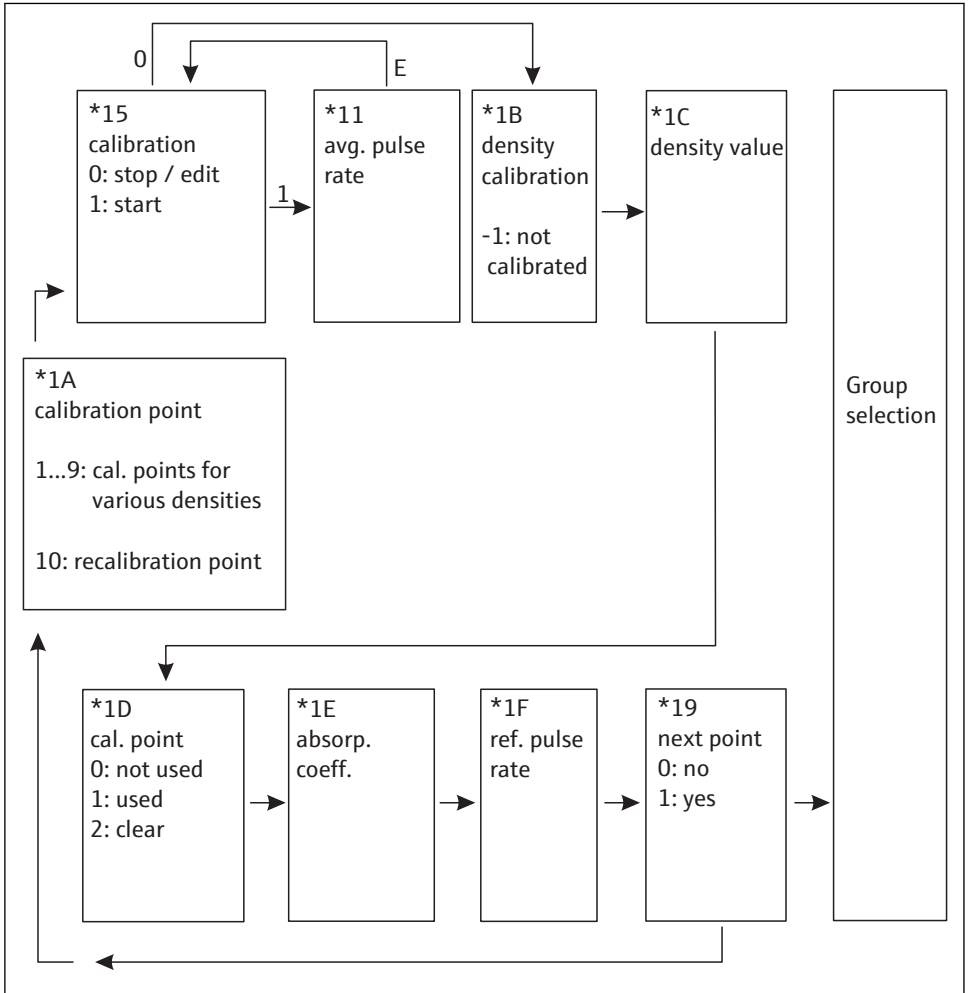

A0037163-EN

"Calibration point" (*1A)

Local display
Calibration point *1A
✓ 1
2
3

This function is used to select the calibration point which will be entered.

Further options:

- "1" to "9": calibration points for various densities
- "10": Point for recalibration. Once the calibration point has been entered, I_0 is recalculated according to the current measuring conditions. The absorption coefficient μ from the original calibration remains unchanged. Calibration point "10" can be entered if the measuring conditions have changed, e.g. as a result of deposit buildup in the measuring tube.

"Calibration" (*15)

Local display
Calibration *15
Stop/edit
Start

This function is used to start automatic entry of the selected calibration point.

Options:

- **Stop/edit**

This option must be selected if:

- The calibration point is not to be entered (e.g. because it has already been entered). The pulse rate of the calibration point is then displayed in the following function **"Density calib." (*1B)**. This value can be changed if required.
- The calibration point is to be entered manually. The Gammapilot M changes to the **"Density calib." (*1B)** function.

- **Start**

This option is used to start automatic entry of the calibration point. The Gammapilot M then changes to the **"Avg. pulse rate" (*11)** function.

"Avg. pulse rate" (*11)

Local display
Avg. pulse rate *11
1983 cps

The average pulse rate is displayed with this function (after the selection of "Start" in the previous function). Initially, this value fluctuates (because of the decay statistics), but reaches

an average value over time due to integration. The longer the averaging is performed, the lower the fluctuations.

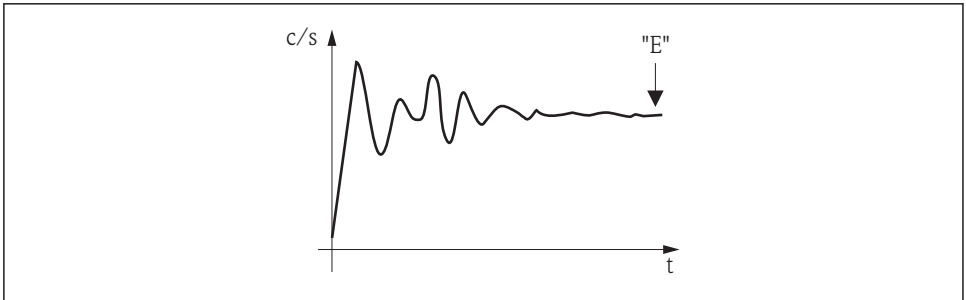

A0018118

When the value is sufficiently stable users can quit the function by pressing \boxed{E} . After this, the Gammapilot M changes to the **"Calibration" (*15)** function. Here the **"Stop/edit"** option must be selected to stop the integration. The value is then automatically transmitted to the **"Density adjustment" (*1B)** function.



Density calibration

- The maximum integration time (= averaging time) is 1000 s. After this time, the value is automatically transmitted to the **"Density calibration (*1B)** function.
- During the integration, a sample of the measured material must be taken. Its density must then be determined (e.g. in the laboratory).
- Integration is not terminated by pressing \boxed{E} in the **"Avg. pulse rate" (*11)** function. Integration continues until **"Stop/edit"** is selected in the **"Calibration" (*15)** function. For this reason, there may be a slight deviation between the last average (integrated) pulse rate displayed and the final **"Density calibration (*1B)**.

"Density calibration" (*1B)

Local display
Density calibration *1B 1983 cps

The pulse rate of the calibration point is displayed in this function. Press \boxed{E} to confirm the value and complete the entry of the calibration point. If a calibration has not yet been performed for the current point, "-1" is displayed. There are two options if this occurs:

- Either return to the **"Calibration" (*15)** function and restart the calibration
- Or enter a known or calculated pulse rate (manual calibration)

"Density value" (*1C)

Local display
Density value *1C 0.9963 g/cm ³

This function is used to specify the density of the calibration point. The value must be determined using a sample in the laboratory.



The temperature effect must be taken into account when entering the density value. The density entered must refer to the temperature at which the pulse rate has been determined. If the density and the pulse rate have been determined at different temperatures, the density value must be corrected accordingly before it is entered.

"Calibration point" (*1D)

Local display
Calibration point *1D Not used <input checked="" type="checkbox"/> Used Clear

This function is used to specify whether the current calibration point is to be used or not.

Options:

- **Not used**

The calibration point is **not** used. It can be reactivated subsequently, however.

- **Used**

The calibration point is used.

- **Clear**

The calibration point is deleted. It cannot be reactivated subsequently.

"Absorption coefficient" (*1E)

Local display
Absorp. coeff. *1E 7.70 mm ² /g

This function is used to display the absorption coefficient μ which results from the calibration points that are currently active. The displayed value is used to check plausibility.



If only one calibration point is active, the absorption coefficient is not calculated and the last valid value is used instead. The default value $\mu = 7.70 \text{ mm}^2/\text{g}$ is used during initial commissioning and following a reset. This value can be changed by the user, however.

"Reference pulse rate" (*1F)

Local display
Ref. pulse rate *1F 31687 cps

This function is used to display the reference pulse rate I_0 which has been calculated from the calibration points currently active. The value cannot be edited.



I_0 is the pulse rate when the tube is empty (theoretical reference value). Generally, the value is significantly higher than any real pulse rates occurring during the measurement.

"Next point" (*19)

Local display
Next point *19 ✓ No Yes

This function is used to specify whether the current calibration point is to be used or not.

Options:

■ No

Select this option if no more calibration points are to be entered or changed. The Gammapiot M then returns to the group selection and the calibration is completed.

■ Yes

Select this option if another calibration point is to be entered or changed. The Gammapiot M then returns to the "**Calibration point**" (*1A) function and the next point can be entered or changed.

6.6.4 Linearization (for concentration measurements)

If the concentration is to be measured in a unit other than the "**Density unit**" (*06), a linearization must be performed after the basic setup. This is done in the "**Linearization**" (*4) function group. The individual functions of this group and the linearization procedure are described in Operating Instructions BA00287F/00/EN, "Gammapiot M - Description of Device Functions", which can be found on the CD-ROM supplied.

6.6.5 Additional settings

After the basic setup, the Gammapiot M outputs the measured value via the current output and the HART signal. The entire measuring range (0 to 100%) is mapped to the range (4 to 20 mA) of the current output. Many additional functions are available for optimizing the measuring point and can be configured as required. For a detailed description of all the device functions, see BA00287F/00/EN, "Gammapiot M - Description of Device Functions", or the CD-ROM supplied.

6.7 Density measurement/temperature-compensated

Perform density measurement as described in the "Calibration for density and concentration measurements" section and then perform temperature calibration (see the "Temperature compensation" section in BA00287F/00/EN "Gammapilot M - Description of Device Functions").

6.8 Gammagraphy detection

See the "Gammagraphy" section of BA00287F/00/EN "Gammapilot M - Description of Device Functions".

6.9 SIL locking (for point level detection 200/400mm PVT scintillator) (HART only)

See the Operating Instructions



BA00236F/00/EN



71402949

www.addresses.endress.com
