

# Operating Instructions

## RIA452

Panel meter  
with pump control

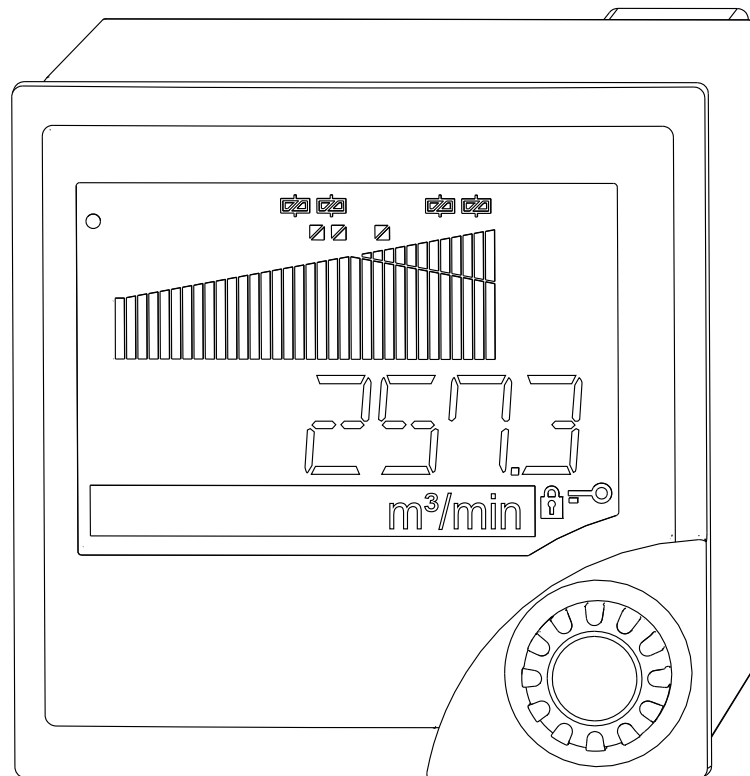







## Table of contents

<b>1</b>	<b>Document information</b> .....	<b>4</b>	<b>13</b>	<b>Technical data</b> .....	<b>48</b>
1.1	Document conventions .....	4	13.1	Input .....	48
<b>2</b>	<b>Safety instructions</b> .....	<b>6</b>	13.2	Output .....	49
2.1	Requirements for the personnel .....	6	13.3	Power supply .....	51
2.2	Designated use .....	6	13.4	Performance characteristics .....	52
2.3	Operational safety .....	6	13.5	Installation .....	54
2.4	Product safety .....	7	13.6	Environment .....	54
<b>3</b>	<b>Incoming acceptance and product identification</b> .....	<b>8</b>	13.7	Mechanical construction .....	55
3.1	Product identification .....	8	13.8	Operability .....	56
3.2	Scope of delivery .....	8	13.9	Certificates and approvals .....	57
3.3	Storage and transport .....	8	13.10	Supplementary documentation .....	57
<b>4</b>	<b>Installation</b> .....	<b>9</b>	<b>14</b>	<b>Appendix</b> .....	<b>58</b>
4.1	Installation conditions .....	9	14.1	Flow conversion .....	58
4.2	Mounting the display unit .....	9	<b>Index</b> .....		<b>59</b>
<b>5</b>	<b>Electrical connection</b> .....	<b>10</b>			
5.1	Universal input option .....	11			
5.2	Connecting the device .....	12			
5.3	Post-connection check .....	14			
<b>6</b>	<b>Operability</b> .....	<b>15</b>			
6.1	Overview of operation options .....	15			
6.2	Structure and function of the operating menu .....	16			
6.3	Access to the operating menu via the local display .....	17			
<b>7</b>	<b>Commissioning</b> .....	<b>20</b>			
7.1	Function check .....	20			
7.2	Switching on the measuring device .....	20			
7.3	Device configuration .....	20			
<b>8</b>	<b>Maintenance</b> .....	<b>43</b>			
<b>9</b>	<b>Accessories</b> .....	<b>43</b>			
9.1	Device-specific accessories .....	43			
<b>10</b>	<b>Troubleshooting</b> .....	<b>44</b>			
10.1	Troubleshooting instructions .....	44			
10.2	Process error messages .....	44			
<b>11</b>	<b>Return</b> .....	<b>47</b>			
<b>12</b>	<b>Disposal</b> .....	<b>47</b>			







# 1 Document information

## 1.1 Document conventions





### 1.1.1 Safety symbols







Symbol	Meaning
	<b>DANGER!</b> This symbol alerts you to a dangerous situation. Failure to avoid this situation will result in serious or fatal injury.
	<b>WARNING!</b> This symbol alerts you to a dangerous situation. Failure to avoid this situation can result in serious or fatal injury.
	<b>CAUTION!</b> This symbol alerts you to a dangerous situation. Failure to avoid this situation can result in minor or medium injury.
	<b>NOTE!</b> This symbol contains information on procedures and other facts which do not result in personal injury.

### 1.1.2 Electrical symbols

Symbol	Meaning
	Direct current
	Alternating current
	Direct current and alternating current
	<b>Ground connection</b> A grounded terminal which, as far as the operator is concerned, is grounded via a grounding system.
	<b>Protective ground connection</b> A terminal which must be connected to ground prior to establishing any other connections.
	<b>Equipotential connection</b> A connection that has to be connected to the plant grounding system: This may be a potential equalization line or a star grounding system depending on national or company codes of practice.

### 1.1.3 Symbols for certain types of information

Symbol	Meaning
	<b>Permitted</b> Procedures, processes or actions that are permitted.
	<b>Preferred</b> Procedures, processes or actions that are preferred.
	<b>Forbidden</b> Procedures, processes or actions that are forbidden.
	<b>Tip</b> Indicates additional information.
	Reference to documentation

Symbol	Meaning
	Reference to page
	Reference to graphic
	Series of steps
	Result of a step
	Help in the event of a problem
	Visual inspection

#### 1.1.4 Registered trademarks

##### **HART®**

Registered trademark of the HART Communication Foundation, Austin, USA

##### **Applicator®, FieldCare®, Field Xpert™, HistoROM®**

Registered or registration-pending trademarks of the Endress+Hauser Group

## 2 Safety instructions

### 2.1 Requirements for the personnel

The personnel for installation, commissioning, diagnostics and maintenance must fulfill the following requirements:

- ▶ Trained, qualified specialists must have a relevant qualification for this specific function and task.
- ▶ Are authorized by the plant owner/operator.
- ▶ Are familiar with federal/national regulations.
- ▶ Before starting work, read and understand the instructions in the manual and supplementary documentation as well as the certificates (depending on the application).
- ▶ Follow instructions and comply with basic conditions.

The operating personnel must fulfill the following requirements:

- ▶ Are instructed and authorized according to the requirements of the task by the facility's owner-operator.
- ▶ Follow the instructions in this manual.

### 2.2 Designated use

The process display unit analyzes analog process variables and depicts them on its multicolored display. Processes can be monitored and controlled using outputs and limit relays. The device provides the user with a wide range of software functions for this purpose. Power can be supplied to 2-wire sensors with the integrated transmitter power supply.

- The device is seen as an associated electrical apparatus and may not be installed in hazardous areas.
- The manufacturer does not accept liability for damage caused by improper or non-designated use. The device may not be converted or modified in any way.
- The device is designed for installation in a panel and may only be operated in an installed state.

### 2.3 Operational safety

Risk of injury.

- ▶ Operate the device in proper technical condition and fail-safe condition only.
- ▶ The operator is responsible for interference-free operation of the device.

#### Conversions to the device

Unauthorized modifications to the device are not permitted and can lead to unforeseeable dangers.

- ▶ If, despite this, modifications are required, consult with Endress+Hauser.

#### Repair

To ensure continued operational safety and reliability,

- ▶ Carry out repairs on the device only if they are expressly permitted.
- ▶ Observe federal/national regulations pertaining to repair of an electrical device.
- ▶ Use original spare parts and accessories from Endress+Hauser only.

## **2.4 Product safety**

This measuring device is designed in accordance with good engineering practice to meet state-of-the-art safety requirements, has been tested, and left the factory in a condition in which it is safe to operate.

It meets general safety standards and legal requirements. It also complies with the EC directives listed in the device-specific EC Declaration of Conformity. Endress+Hauser confirms this by affixing the CE mark to the device.

## 3 Incoming acceptance and product identification

### 3.1 Product identification

#### 3.1.1 Nameplate

Compare the nameplate on the device with the following figure:

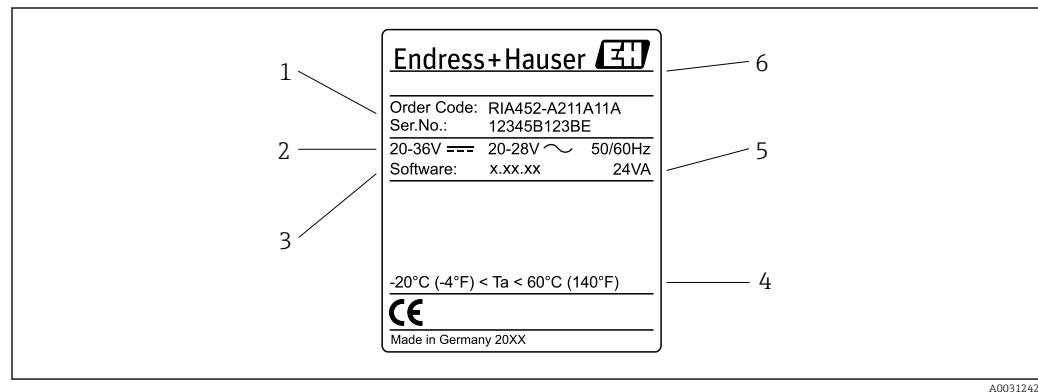

1 Nameplate of the process display unit (example)

- 1 Order code and serial number of the device
- 2 Power supply
- 3 Software version number
- 4 Ambient temperature
- 5 Power consumption
- 6 Name and address of manufacturer

### 3.2 Scope of delivery

The scope of delivery of the process display unit comprises:

- Process display unit for panel mounting
- Multilanguage Brief Operating Instructions as hard copy
- CD-ROM with PC configuration software and interface cable RS232 (optional)
- Fixing clips
- Sealing ring

Please note the device accessories in Section 'Accessories' → 43.

### 3.3 Storage and transport

#### Storage temperature

-30 to +70 °C (-22 to +158 °F)





## 4 Installation

### 4.1 Installation conditions

The permitted ambient conditions must be observed during installation and operation (see the "Technical data" section of the Operating Instructions). The device must be protected from exposure to heat.

#### 4.1.1 Installation dimensions

Required panel cutout 92 mm (3.62 in)x92 mm (3.62 in). Ensure an installation depth of 150 mm (5.91 in) for the device plus cable. For additional dimensions, see →  2,  9 and the "Technical data" section of the Operating Instructions.

#### 4.1.2 Mounting location

Installation in a panel (according to EN 60529). The mounting location must be free from vibrations.

#### 4.1.3 Orientation

Horizontal,  $\pm 45^\circ$  in every direction.

### 4.2 Mounting the display unit

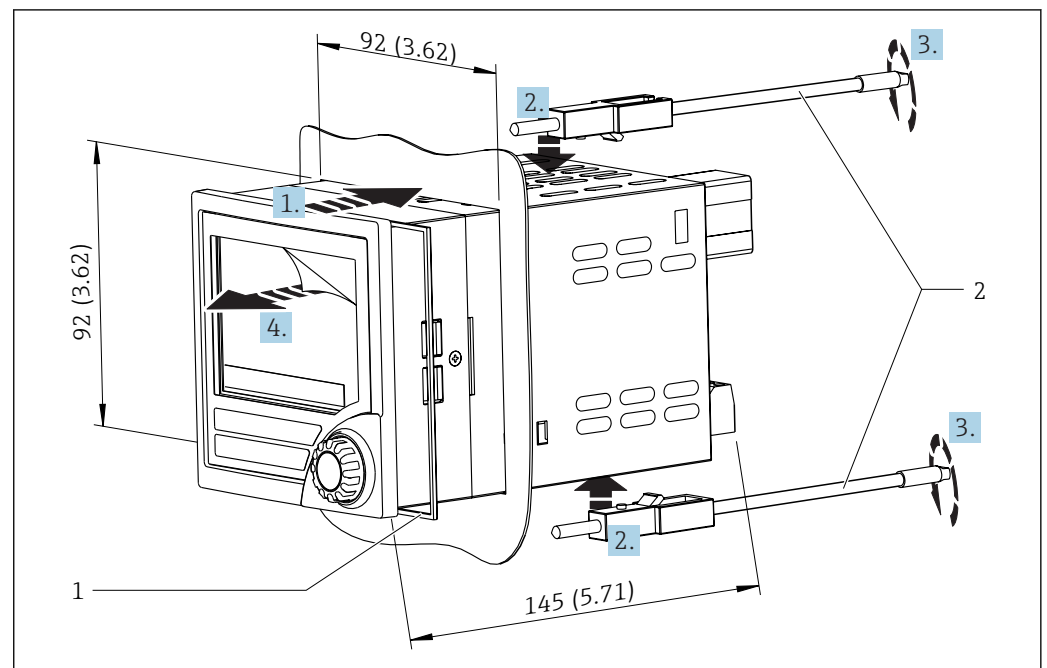

 2 Installation in a panel

#### Mounting the display unit

1. Push the device with the sealing ring (item 1) through the panel cutout from the front.
2. Hold the device level and clip the fastening clips (item 2) into the openings provided.
3. Tighten the screws of the fastening clips uniformly using a screwdriver.

- 4. Remove the protective foil from the display.

## 5 Electrical connection

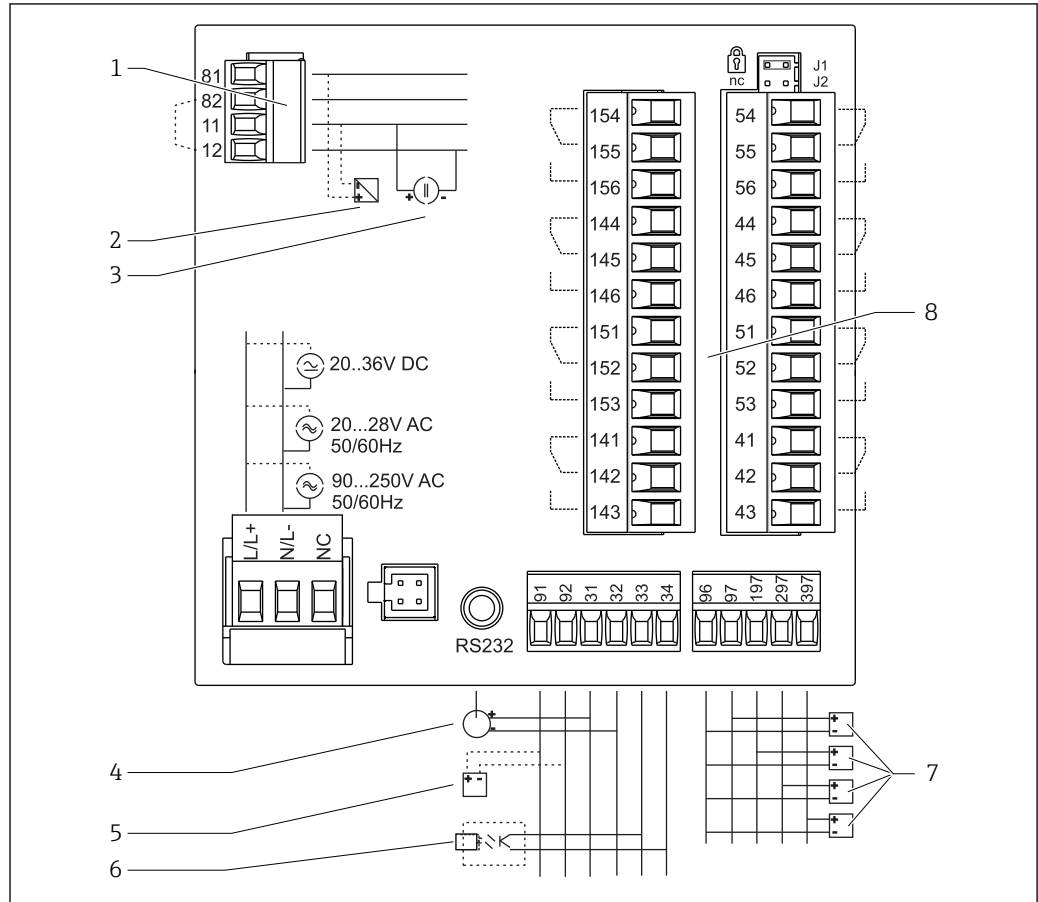

A0031253

3 Terminal assignment of the process display unit. Internal circuits represented by dashed lines.

- 1 Current input, terminals 12 and 82 are internally bridged.
- 2 Current loop transmitter power supply max. 22 mA current input
- 3 Current input 0 to 20 mA
- 4 Analog output 0 to 20 mA, 0 to 10 V<sub>DC</sub>
- 5 Transmitter power supply, 24 V, ≤250 mA.
- 6 Digital output, passive open collector, max. 28 V, 200 mA
- 7 Digital inputs as per DIN 19240; voltage level: -3 to 5 V low, 12 to 30 V high, input current typically 3 mA (with overload and reverse polarity protection), input voltage max. 34.5 V, sampling frequency max. 10 Hz
- 8 Relay output: Relays 1-8; 250 V<sub>AC</sub>/30 V<sub>DC</sub>, 3 A

Terminal	Terminal assignment	Description
L/L+	L for AC L+ for DC	Power supply
N/L-	N for AC L- for DC	
NC	Not connected	
J1	Jumper for locking device operation via hardware. If the jumper is set to J1, the configuration cannot be modified.	The device can always be configured with the PC software via RS232 even if the jumper is set to J1.
J2	Not connected	
11	+0/4 to 20 mA	Current input

Terminal	Terminal assignment	Description
12	Signal ground (current)	
81	24 V sensor power supply 1	Transmitter power supply (optionally intrinsically safe)
82	Ground, sensor power supply 1	
41	Normally closed (NC)	Relay 1
42	Common (COM)	
43	Normally open (NO)	
51	Normally closed (NC)	Relay 2
52	Common (COM)	
53	Normally open (NO)	
44	Normally closed (NC)	Relay 3
45	Common (COM)	
46	Normally open (NO)	
54	Normally closed (NC)	Relay 4
55	Common (COM)	
56	Normally open (NO)	
141	Normally closed (NC)	Relay 5
142	Common (COM)	
143	Normally open (NO)	
151	Normally closed (NC)	Relay 6
152	Common (COM)	
153	Normally open (NO)	
144	Normally closed (NC)	Relay 7
145	Common (COM)	
146	Normally open (NO)	
154	Normally closed (NC)	Relay 8
155	Common (COM)	
156	Normally open (NO)	
96	Ground for digital status inputs	Digital inputs
97	+ digital status input 1	
197	+ digital status input 2	
297	+ digital status input 3	
397	+ digital status input 4	
31	+ analog output	Analog output (optional)
32	Ground, analog output	
33	+ digital output	Digital output (optional)
34	Ground, digital output	
91	24 V sensor power supply 2	Transmitter power supply
92	Ground, sensor power supply 2	

## 5.1 Universal input option

The device can be optionally equipped with a universal input instead of a current input.

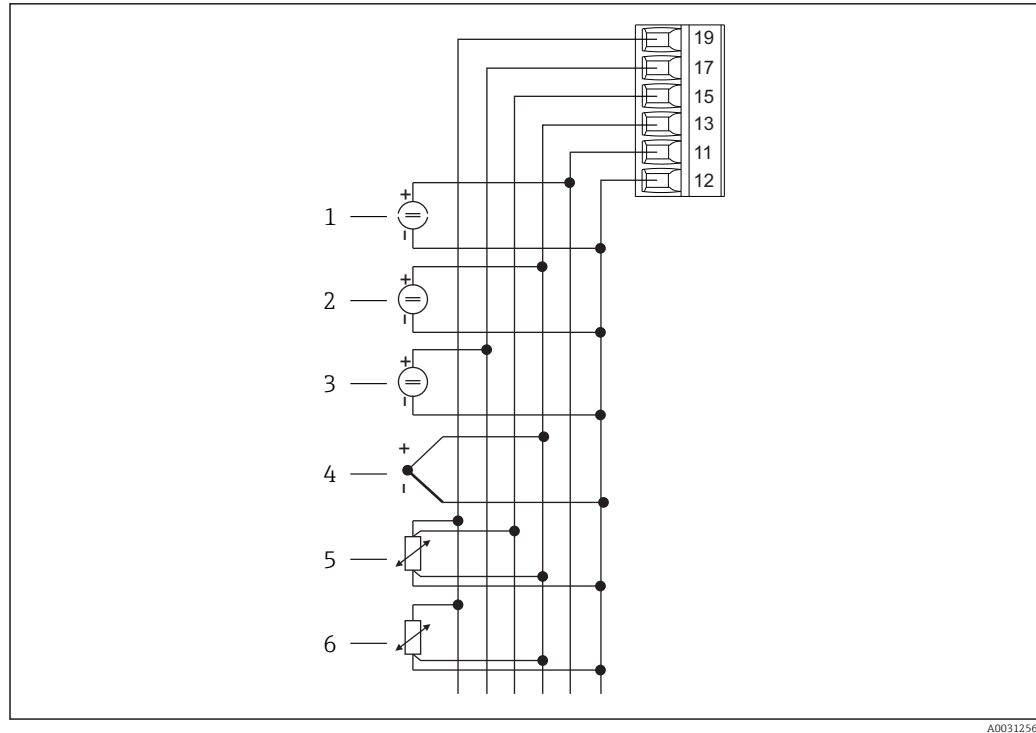

4 Universal input terminal assignment

- |   |                            |   |                                 |
|---|----------------------------|---|---------------------------------|
| 1 | Current input 0/4 to 20 mA | 4 | Thermocouples                   |
| 2 | Voltage input $\pm 1$ V    | 5 | Resistance thermometers, 4-wire |
| 3 | Voltage input $\pm 30$ V   | 6 | Resistance thermometers, 3-wire |

Terminal	Terminal assignment
11	+0/4 to 20 mA signal
12	Signal ground (current, voltage, temperature)
13	+1 V, + thermocouples, - resistance thermometer signal (3-/4-wire)
15	+ resistance thermometer signal (4-wire)
17	+30 V
19	+ resistance thermometer supply (3-/4-wire)

## 5.2 Connecting the device

### **⚠ WARNING**

#### **Danger! Electric voltage!**

- ▶ The entire connection of the device must take place while the device is de-energized.

### 5.2.1 Connecting the power supply

- Before wiring the device, ensure that the supply voltage corresponds to the specification on the nameplate.
- For the 90 to 250 V<sub>AC</sub> (power supply connection) version, a switch marked as a separator, as well as an overvoltage organ (rated current  $\leq 10$  A), must be fitted in the supply line near the device (easy to reach).

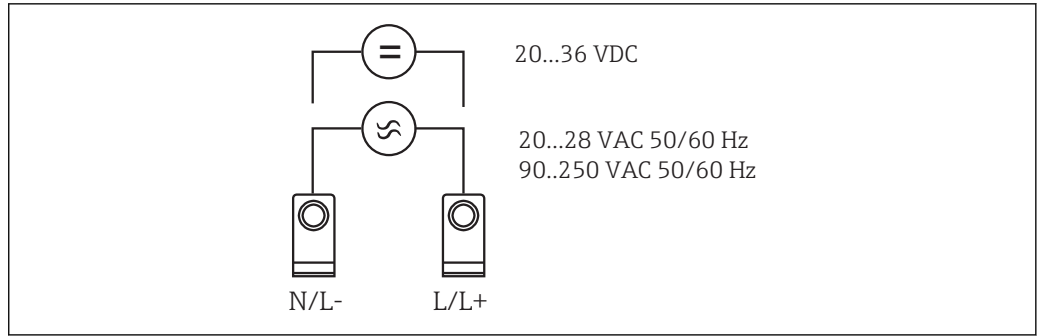

A0031259

5 Connecting the power supply

### 5.2.2 Connecting external sensors

**i** Active and passive sensors with analog, TC, resistance and RTD sensors can be attached to the device.

#### Current input 0/4 to 20 mA

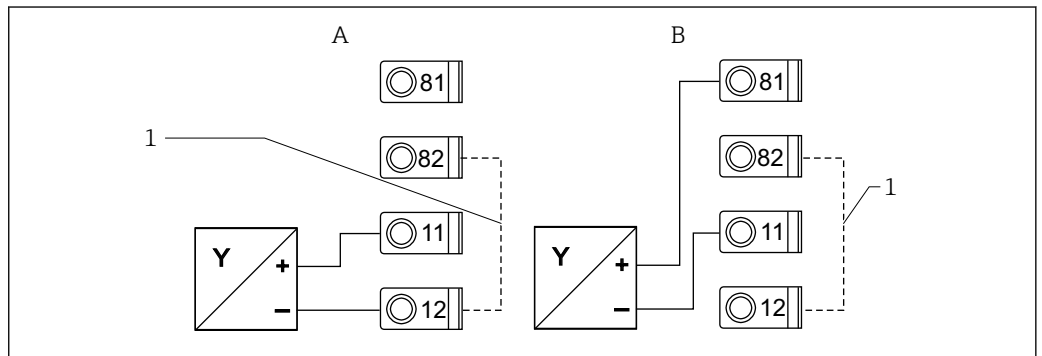

A0031272

6 Connection of the two-wire sensor to the current input 0/4 to 20 mA

- A Active sensor
- B Passive sensor
- 1 Terminals 12 and 82 internally bridged

#### Universal input

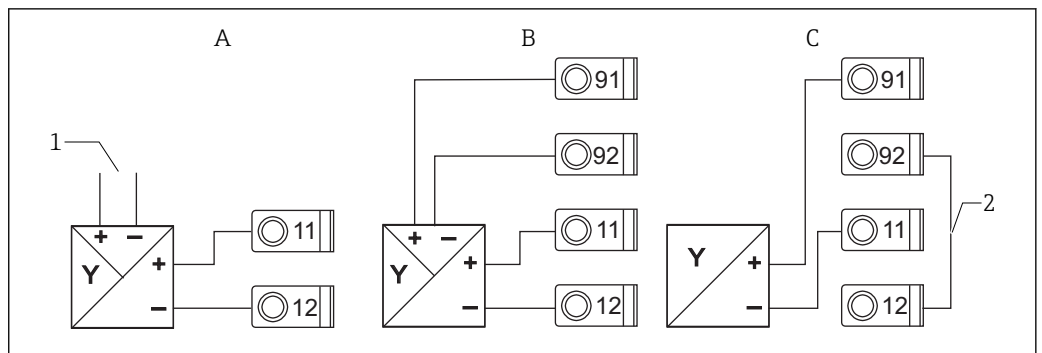

A0031273

7 Connection of the four-wire sensor, transmitter power supply and universal input

- A Active sensor, 4-wire
- 1 Power supply
- B Passive sensor, 4-wire
- C Passive sensor, 2-wire
- 2 Terminals 12 and 92 externally bridged

### 5.3 Post-connection check

Device condition and specifications	Notes
Is the device or cable damaged (visual inspection)?	-

Electrical connection	Notes
Does the supply voltage match the specifications on the nameplate?	90 to 250 V <sub>AC</sub> (50/60 Hz) 20 to 36 V <sub>DC</sub> 20 to 28 V <sub>AC</sub> (50/60 Hz)
Are all of the terminals firmly engaged in their correct slots? Is the coding on the individual terminals correct?	-
Are the mounted cables strain relieved?	-
Are the power supply and signal cables correctly connected?	See wiring diagram on the housing
Are all screw terminals firmly tightened?	-

## 6 Operability

### 6.1 Overview of operation options

#### 6.1.1 Display and operating elements

**i** Remove the protective film from the display as this would otherwise affect the readability of the display.

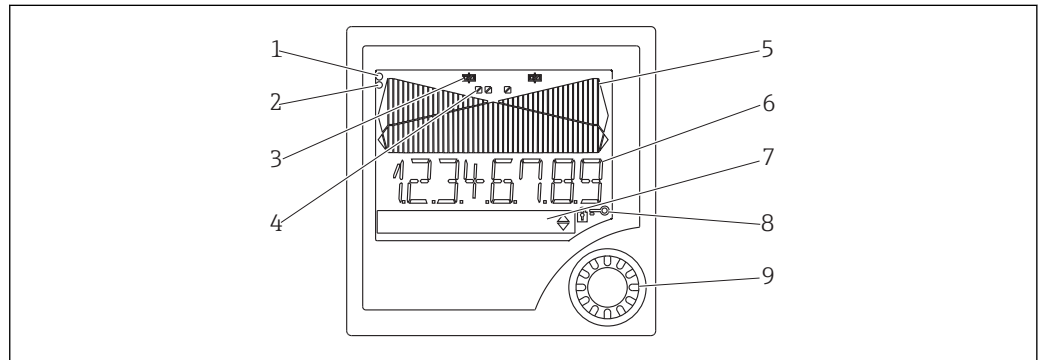

A0031274

**8** Display and operating elements

- 1 Operational indicator, green, is lit when supply voltage is applied
- 2 Fault indicator, red, flashes in the event of a sensor or device error
- 3 Limit indicator: the symbol is displayed if a relay is energized.
- 4 Status of digital inputs: green indicates ready for operation, yellow indicates a signal is pending
- 5 Bar graph, yellow, 42-part, with overranging and underranging in orange/red
- 6 7-digit, 14-segment display, white for measured values
- 7 9x7 dot matrix display, white, for texts, units and menu icons
- 8 Key and padlock symbols, indicate whether device operation is locked (see Section 5.3.3)
- 9 Jog/shuttle dial for local display operation

#### 6.1.2 Display



**i** For troubleshooting information, see the "Troubleshooting" section → **44**.

Range	Display	Relay	Analog output	Totalization
Input current is below lower error limit	Display <b>nnnnn</b>	Fault state	Configured failsafe mode	No totalization
Input current above lower error limit and below lower limit of validity	Display <b>-----</b>	Normal limit value behavior	Normal behavior with max. 10% overrange. No output < 0 mA/0 V possible	Normal behavior (negative totalization not possible)
Input current in valid range	Display scaled measured value	Normal limit value behavior	Normal behavior with max. 10% overrange. No output < 0 mA/0 V possible	Normal behavior (negative totalization not possible)
Input current below upper error limit and above upper limit of validity	Display <b>-----</b>	Normal limit value behavior	Normal behavior with max. 10% overrange. No output < 0 mA/0 V possible	Normal behavior (negative totalization not possible)
Input current above upper error limit	Display <b>uuuuu</b>	Fault state	Configured failsafe mode	No totalization

**Relay indicator**

- Relay not energized: nothing indicated
- Relay energized:  (symbol is lit)

**Status display for digital inputs**

- Digital input configured:  (green)
- Signal at digital input:  (yellow)

**6.2 Structure and function of the operating menu**

M1	<b>Analog input INPUT</b>	<b>Signal type</b>	<b>Type of connection*</b>	<b>Curve</b>	<b>Signal damping</b>	
		Signal type	Connection	Curve	Damp	
		<b>Dimension</b>	<b>Decimal point</b>	<b>0% value</b>	<b>100% value</b>	
		Dimension	Dec. point	0% value	100% value	
		<b>Offset</b>	<b>Reference temperature*</b>	<b>Fixed reference temperature*</b>	<b>Open circuit detection</b>	
		Offset	Comp. temp.	Const. temp.	Open circ.	
M2	<b>Anzeige DISPLAY</b>	<b>Assign numerical display</b>	<b>Alternating display</b>	<b>Assign bargraph</b>	<b>Decimal point bargraph</b>	
		Ref. num.	Displ. sw.	Ref. bargraf	Dec. point	
		<b>Bargraph 0% value</b>	<b>Bargraph 100% value</b>	<b>Assign bargraph</b>		
		Bar 0%	Bar 100%	Ref. bargraf		
M3	<b>Analog output* ANALOG OUT</b>	<b>Assignment</b>	<b>Damping</b>	<b>Output range</b>	<b>Decimal point</b>	
		Ref. num.	Out damp	Out range	Dec. point	
		<b>0% value</b>	<b>100% value</b>	<b>Offset</b>	<b>Output in the event of a fault</b>	
		Out 0%	Out 100%	Offset	Fail mode	
		<b>Value in the event of a fault</b>	<b>Simulation mA</b>	<b>Simulation Volt</b>		
		Fail value	Simu mA	Simu V		
M5	<b>Digital input 1-4 DIGITAL INP</b>	<b>Function digital input 1-4</b>	<b>Active level 1-4</b>	<b>Pump monitoring sampling time</b>		
		Function	Level	Sampl. time		
M10- M17	<b>Limit 1-4 (8)* LIMIT</b>	<b>Assignment</b>	<b>Function 1-4 (8)</b>	<b>Decimal point</b>	<b>Switch point A</b>	<b>Switch point B</b>
		Ref. num	Function	Dec. point	Setpoint A	Setpoint B
		<b>Hysteresis or switchback gradient</b>	<b>Switching delay 1-4 (8) in seconds</b>	<b>Alternate function 1-4</b>	<b>Delay for 1st switch-on every 24 h</b>	<b>Switch-on period for switch-on every 24 h</b>
		Hysteresis	Delay	Alternate	Sw. delay	Sw. period
		<b>Display runtime 1-8</b>	<b>Display switching frequency 1-8</b>	<b>Reset switching frequency and runtime</b>	<b>Relay simulation</b>	
		Runtime	Count	Reset	Simu Relais	
M18	<b>Integration* Integration</b>	<b>Signal source for integration</b>	<b>Precounter</b>	<b>Integration base</b>	<b>Decimal point factor</b>	<b>Conversion factor</b>
		Ref. Integr.	Pre-counter	Integr. base	Dec. factor	Factor
		<b>Dimension totalizer</b>	<b>Decimal point totalizer</b>	<b>Set pre-counter</b>	<b>Set preliminary alarm</b>	<b>Display totalizer</b>



	Dimension	Dec. point T	Set count A	Set count B	Totalizer
	<b>Reset totalizer</b>	<b>Flow calculation</b>	<b>Dimension of input signal</b>	<b>Dimension of linearized value</b>	<b>Decimal point for formula</b>
	Reset total	Calc flow	Dim. Input	Dim. flow	Dec. flow
	<b>Decimal point for display</b>	<b>Alpha value</b>	<b>Beta value</b>	<b>Gamma value</b>	<b>C value</b>
	Dec. point	Alpha	Beta	Gamma	C
	<b>Khafagi- Venturi channels</b>	<b>Venturi channels as per British Standard</b>	<b>Venturi channels as per British Standard</b>	<b>Parshall channels</b>	<b>Parshall- Bowlus channels</b>
	Kha Venturi	Iso-Venturi	BST-Venturi	Parshall	Parshall-Bow
	<b>Rectangular weirs</b>	<b>Rectangular weirs with constriction</b>	<b>Rectangular weirs as per NFX</b>	<b>Rectangular weirs as per NFX with constriction</b>	<b>Trapezoid. weirs</b>
	Rect. WTO	Rect. WThr	NFX Rect. WTO	NFX Rect. WThr	Trap. WTO
	<b>Triangular weirs</b>	<b>Triangular weirs as per British Standard</b>	<b>Triangular weirs as per NFX</b>	<b>Width</b>	
	V. weir	BST V. weir	NFX V. weir	width	
M19	<b>Pulse output*</b> PULSE OUT	<b>Decimal point pulse value</b>	<b>Pulse value</b>	<b>Pulse width</b>	<b>Simulation pulse output</b>
		Dec value	Unit Value	Pulse width	Sim pulseout
M20	<b>Min/Max memory</b> MIN/MAX	<b>Signal source for Min/Max</b>	<b>Decimal point</b>	<b>Display minimum value</b>	
		Ref. Min/Max	Dec. point	Min. value	
		<b>Display maximum value</b>	<b>Reset minimum value</b>	<b>Reset maximum value</b>	
		Max. value	Reset min	Reset max	
M21	<b>Linearization table</b> LIN-TABLE	<b>Number of support points</b>	<b>Dimension of linearized value</b>	<b>Decimal point Y-axis</b>	<b>Delete all support points</b>
		Counts	Dimension	Dec. Y value	Del points
					<b>Display all support points</b>
					Show points
M23- Mxx	<b>Lin. support points</b> NO 01 NO 32	<b>X-axis</b>	<b>Y-axis</b>		
		X value	Y value		
M55	<b>Operating parameters</b> PARAMETERS	<b>User code</b>	<b>Limit value lock</b>	<b>Program name</b>	<b>Program version</b>
		User code	Limit lock	Prog. name	Version
		<b>Relay lock time</b>	<b>Relay failsafe mode</b>	<b>Time for gradient evaluation</b>	<b>Failsafe mode 4-20 mA input</b>
		Lock time	Rel. Mode	Grad. Time	Namur
		<b>Error limit 2</b>	<b>Error limit 3</b>	<b>Error limit 4</b>	<b>Display contrast</b>
		Range 2	Range 3	Range 4	Contrast
M56	SERVICE	Only for service staff. The service code must be entered.			
M57	EXIT	Exit the menu. If you have changed parameters, you are asked whether you want to save the changes.			
M58	SAVE	Changes are saved and you exit the menu.			
*) Only available if the option in question is installed in the device					

### 6.3 Access to the operating menu via the local display

Press the jog/shuttle dial for longer than 3 seconds to activate the operating menu.

### 6.3.1 Operation via the jog/shuttle dial

#### A) 3-key function

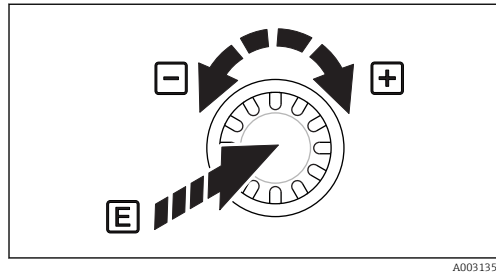

- Press = "Enter"
- Rotate in clockwise direction = "+"
- Rotate in counterclockwise direction = "-"

9 Operation via the jog/shuttle dial

#### B) Selection from list

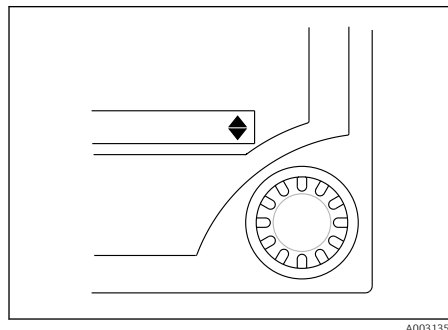

- ▼ Arrow pointing down:  
Option is at the top of the picklist. The other entries become visible when the jog/shuttle is turned in the clockwise direction.
- ▲ Both arrows visible:  
▼ User is in the middle of the picklist.
- ▲ Arrow pointing up:  
The end of the picklist is reached. The user moves back towards the start when the jog/shuttle is turned in the counterclockwise direction.

10 Selection from list via the jog/shuttle dial

### 6.3.2 Entering text

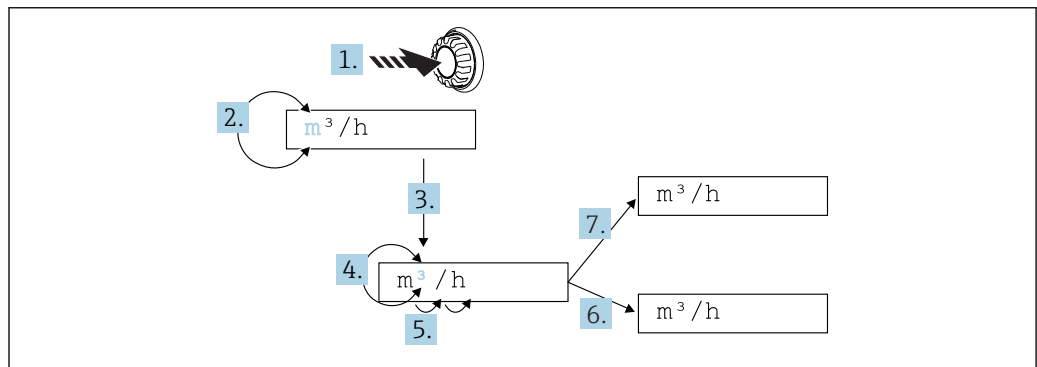

11 Texteingabe am Prozessanzeiger

1. Press jog/shuttle dial for longer than 3 s.  
↳ The first digit flashes.
2. In order to alter the character turn the jog/shuttle dial to the left or right.
3. Press jog/shuttle dial briefly.  
↳ The character is accepted and the next one flashes.
4. In order to alter the character turn the jog/shuttle dial to the left or right. Select the "<" symbol to go back to the previous digit.
5. Press jog/shuttle dial briefly.  
↳ The character is accepted and the next one flashes.

6. Set / change all digits in this way. At the last digit, press the jog/shuttle dial briefly.
  - ↳ The input is accepted.
7. Alternatively press the jog/shuttle dial for longer than 1 s at any position and release it.
  - ↳ Input is cancelled.

### Possible characters

The following characters can be entered:

Blank

+ABCDEFGHIJKLMNPOQRSTUVWXYZabcdefghijklmnopqrstuvwxyz0123456789/!%  
°23+-.:;\*()< (go back)



## 6.3.3 Disabling the programming mode

### User code

The configuration can be protected against unintentional access by means of a four-digit code. This code is defined in menu item 55 "Parameter/user code". All the parameters remain visible but can only be changed after entering the user code. The "key" symbol is shown on the display.

If the limit values are also to be locked, the "Limit code" must be set to "On" in menu item 55. Limit values can then only be changed after entering the user code. If the limit code is set to "Off", limit values can be changed without entering the user code. All the other parameters are locked, however.

### Hardware locking

In addition, configuration can also be locked using a connector on the rear of the device (→  12,  19). This is indicated by the "padlock" symbol on the display.

To hardware-lock the measuring device, insert the jumper into position J1 in the top righthand corner on the rear of the device.

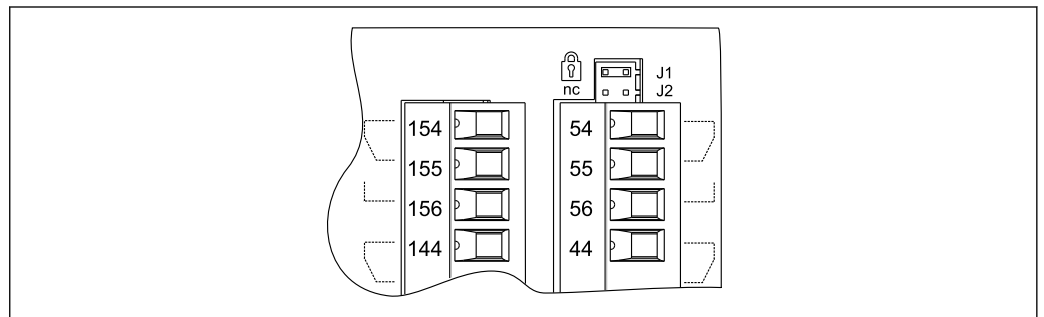

A0031364

 12 Position of the jumper on the rear of the device

 The hardware lock does not affect the PC operating software.

## 7 Commissioning

### 7.1 Function check

Make sure that all post-connection checks have been carried out before you commission your device:

Checklist connection check →  14

 Remove the protective strip from the display as this restricts display legibility otherwise.

### 7.2 Switching on the measuring device

Once the operating voltage is applied, the green LED indicates that the device is operational.

- When the unit is delivered, the device parameters are used as per the factory settings.
- When commissioning a device already configured or preset, measuring is immediately started as per the settings. The limit values only switch once the first measured value has been determined.
- The limit values are only activated as per their configuration once a valid measured value is present.

### 7.3 Device configuration

This section describes all the configurable instrument parameters with the associated value ranges and factory settings (default values, marked in bold).

### 7.3.1 Analog input - INPUT/M1

All the parameters that can be selected for the input can be found under the analog input menu item which is marked as INPUT in the device.

Function (menu item)	Parameter setting	Description
Signal type	<b>4 - 20 mA</b> 0 - 20 mA 0 - 5 mA <sup>(*)</sup> 0 - 100 mV <sup>(*)</sup> 0 - 200 mV <sup>(*)</sup> 0 - 1 V <sup>(*)</sup> 0 - 10 V <sup>(*)</sup> ± 150 mV <sup>(*)</sup> ± 1 V <sup>(*)</sup> ± 10 V <sup>(*)</sup> ± 30 V <sup>(*)</sup> Type B (IEC584) <sup>(*)</sup> Type J (IEC584) <sup>(*)</sup> Type K (IEC584) <sup>(*)</sup> Type L (DIN43710) <sup>(*)</sup> Type L (GOST) <sup>(*)</sup> Type N (IEC584) <sup>(*)</sup> Type R (IEC584) <sup>(*)</sup> Type S (IEC584) <sup>(*)</sup> Type T (IEC584) <sup>(*)</sup> Type U (DIN43710) <sup>(*)</sup> Type D (ASTME998) <sup>(*)</sup> Type C (ASTME998) <sup>(*)</sup> PT50 (GOST) <sup>(*)</sup> PT100 (IEC751) <sup>(*)</sup> PT100 (JIS1604) <sup>(*)</sup> PT100 (GOST) <sup>(*)</sup> PT500 (IEC751) <sup>(*)</sup> PT500 (JIS1604) <sup>(*)</sup> PT500 (GOST) <sup>(*)</sup> PT1000 (IEC751) <sup>(*)</sup> PT1000 (JIS1604) <sup>(*)</sup> PT1000 (GOST) <sup>(*)</sup> Cu50 (GOST) <sup>(*)</sup> Cu100 (GOST) <sup>(*)</sup> 30 - 3000 Ohm <sup>(*)</sup>	Selects the signal type of the connected sensor. Parameters marked with an asterisk (*) can only be selected with the universal input option.
Connection	<b>3 Wire</b> 4 Wire	Configures the sensor connection in 3-wire or 4-wire technology. Can only be selected for "Signal type" 30- 3000 Ω, PT50/100/1000, Cu50/100
Curve	<b>Linear</b> Quad. °C °F Kelvin	Linear or quadratic (quad.) characteristic of the sensor used. Can be selected for analog signals. °C, °F, Kelvin physical measured variable, can be selected for temperature sensors.
Damp	0...99.9 <b>0</b>	Signal damping of measuring input with 1st order low pass. Time constant can be selected from 0 to 99.9 s.
Dimension	XXXXXXXX <b>%</b>	The technical unit or an arbitrary text for the measured value of the sensor can be configured here. Max. length 9 characters.
Dec. point	XXXXX <b>XXXX.X</b> XXX.XX XX.XXX X.XXXX	Number of places after the decimal point for displaying the measured value.
0% value	-99999...99999 <b>0.0</b>	Start value of measured value, can be selected for analog signal types.

Function (menu item)	Parameter setting	Description
100% value	-99999...99999 <b>100.0</b>	End value of measured value, can be selected for analog signal types.
Offset	-99999...99999 <b>0.0</b>	Shifts the zero point of the response curve. This function is used to adjust the sensor.
Comp. temp	<b>Intern</b> Const	Reference temperature for thermocouple measurement. An internal cold junction (= Intern) or a constant value (= const) can be selected.
Const. temp	9999.9 <b>20.0</b>	Fixed reference temperature. This can only be selected if const is set for "Cmp. Temp".
Open circ.	<b>No</b> Yes	Switch cable open circuit detection off or on for thermocouples

### Adjusting the analog input

The input can be adjusted to the sensor with the aid of the following parameters. For current, voltage and resistance sensors, a scaled value is calculated from the sensor signal.

For temperature outputs, the scaled value is calculated from linearization tables. The temperature value can be converted to degrees Celsius, degrees Fahrenheit or Kelvin. In addition, the temperature value can be corrected by means of an offset.

 The signal types 4 to 20 mA, thermocouples and resistance thermometers are monitored for cable open circuit. Long reaction times can occur in the case of resistance thermometers.

### 7.3.2 Display - DISPLAY/M2

All of the display settings are grouped under this menu item.

Function (menu item)	Parameter setting	Description
Ref. num.	Input Lin.table Total <sup>(*)</sup> Inp.+Lint. Inp.+Tot. <sup>(*)</sup> Lint.+Tot. <sup>(*)</sup> In+Lin+Tot <sup>(*)</sup> Batch <sup>(*)</sup>	For choosing the display value on the display. (If a combination is selected, e.g. "Inp.+Lint", the display alternates between the selected display values, e.g. measured value (Inp.) and linearized measured value (Lint.)) <ul style="list-style-type: none"> <li>■ Input = measured value</li> <li>■ Lin. table = linearized measured value or current flow rate for calculation of channel</li> <li>■ Total = integrated value</li> <li>■ Inp.+Lint. = alternates between measured value and linearized measured value</li> <li>■ Inp.+Tot. = alternates between measured value and integrated value</li> <li>■ Lint.+Tot. = alternates between linearized measured value and integrated value</li> <li>■ In+Lin+Tot = measured value, linearized measured value or integrated value</li> <li>■ Batch = preset counter</li> </ul> Settings marked with an asterisk (*) are only available if the pulse output or integration option is available and has been configured.
Display sw.	0...99 s <b>0</b>	Selectable period for displaying the individual values if combinations of display values have been selected under "Ref. num.". This setting is only available if the pulse output or integration option is available and has been configured.
Ref. bargraf	<b>Input</b> Lintab	Selects the signal source for the bar graph.

Function (menu item)	Parameter setting	Description
Dec. point	XXXXX XXXX.X XXX.XX XX.XXX X.XXXX	Number of digits after the decimal point for bar graph scaling.
Bar 0%	-99999...99999 0.0	Start value for the bar graph
Bar 100%	-99999...99999 100.0	End value for the bar graph
Bar rise	Right Left	Bar graph orientation. <ul style="list-style-type: none"> <li>Right = 100% value (rising from left to right)</li> <li>Left = 100% value left (falling from left to right)</li> </ul>

### 7.3.3 Analog output - ANALOG OUT/M3

 Dieser Menüpunkt ist nur vorhanden, wenn die Option "Analogausgang" in Ihrem Gerät bestückt ist.

Function (menu item)	Parameter setting	Description
Ref. num.	Input Lintab	Selects which value is output at the analog output. <ul style="list-style-type: none"> <li>Input = measured value</li> <li>Lintab = linearized measured value or current flow rate for calculation of channel</li> </ul>
Out damp	0..99.9 0	Signal damping of measuring input with 1st order low pass. Time constant can be selected from 0 to 99.9 s.
Out range	Off 0 - 20 mA 4 - 20 mA 0 - 10 V 2 - 10 V 0 - 1 V	Signal type of output. "Off" switches the output signal off completely.
Dec. point	XXXXX XXXX.X XXX.XX XX.XXX X.XXXX	Number of places after the decimal point for outputting the measured value. Can be selected for analog signal types.
Out 0%	-99999...99999 0.0	Start value of the output signal
Out 100%	-99999...99999 100.0	End value of the output signal
Offset	-999.99...999.99 0.00	Shifts the zero point of the output curve in mA or V.
Fail mode	Hold Const Min Max	Output value if a sensor or device error occurs. <ul style="list-style-type: none"> <li>Hold = last valid value</li> <li>Const = freely selectable value</li> <li>Min = output value 3.5 mA at 4 to 20 mA, otherwise 0 V or 0 mA</li> <li>Max = output value 22.0 mA at 0/20 mA, otherwise 1.1 V or 11 V</li> </ul>
Fail value	0...999.99 0.00	The freely selectable value for "Fail mode = Const" can be set here. <ul style="list-style-type: none"> <li>Current output: 0 to 22 mA</li> <li>Voltage output: 0 to 11 V</li> </ul>

Function (menu item)	Parameter setting	Description
Simu mA	<b>OFF</b> 0.0 mA 3.6 mA 4 mA 10 mA 12 mA 20 mA 21 mA	Simulates the current output and outputs the selected current at the output, regardless of the input value. Is automatically set to OFF when the Simu mA menu item is exited. The parameter is only available if the mA parameter is configured in Out range.
Simu V	<b>OFF</b> 0.0 V 5.0 V 10.0 V	Simulates the voltage output and outputs the selected voltage at the output, regardless of the input value. Is automatically set to OFF when the Simu V menu item is exited. The parameter is only available if the V parameter is configured in Out range.

### 7.3.4 Digital input - DIGITAL INP./M5

The settings for the digital status inputs, e.g. for monitoring pumps, starting/stopping the counter or resetting the min/max-value memory are grouped in this section.

-  The digital inputs 1 to 4 are permanently assigned to relays 1 to 4 in the PUMP function. Relay 1 is monitored by digital input 1, relay 2 by digital input 2 etc.
- When the "Batch" function is used, digital input 1 is permanently assigned to a preset value count function. Configuration for this digital input is then not possible.

Function (menu item)	Parameter setting	Description
Function	Off Pump Res Tot. (*) Start/Stop (*) Res MinMax	Function of the selected digital input. <ul style="list-style-type: none"> <li>▪ Off = Off</li> <li>▪ Pump = pump monitoring (see Pump monitoring function)</li> <li>▪ Res Tot. = reset the totalizer</li> <li>▪ Start/Stop = start or stop the totalizer</li> <li>▪ Res MinMax = reset the min/max memory values</li> </ul> Parameters marked with an asterisk (*) are only available for the pulse output option if this function has been configured.
Level	<b>Low</b> High	Selects the side for evaluation. <ul style="list-style-type: none"> <li>▪ Low = descending side</li> <li>▪ High = increasing side</li> </ul>
Sampl. time	0..99 <b>0</b>	Defines the time (in seconds) within which pump feedback at the digital input is to be expected. If there is no feedback within the defined time, an error message is generated and a second pump is activated if more than one pump is available. The setting for Sampl. time determines the type of monitoring of the digital input. <ul style="list-style-type: none"> <li>▪ Sampl. time = 0 means fault monitoring</li> <li>▪ Sampl. time &gt; 0 means startup monitoring</li> </ul>

#### Pump monitoring function

The digital inputs 1 to 4 are permanently assigned to relays 1 to 4 for the pump monitoring function. This function is activated for the relevant digital input using the "Function" parameter. "Pump" must be selected here.

Generally, two different types of monitoring are possible. The setting for "Sampl. time" determines the operating mode chosen.



- **Fault monitoring: Sampl. Time = 0**  
In the case of fault monitoring, the level at the digital input is changed by a fault on the pump.
- **Startup monitoring: Sampl. Time > 0**  
In the case of startup monitoring, feedback on the correct startup of the pump is sent to the panel meter via a level change at the digital input.

#### a) Fault monitoring operating mode

The status signal indicates availability of the pump in the fault monitoring operating mode. If a fault occurs, the status signal changes accordingly.

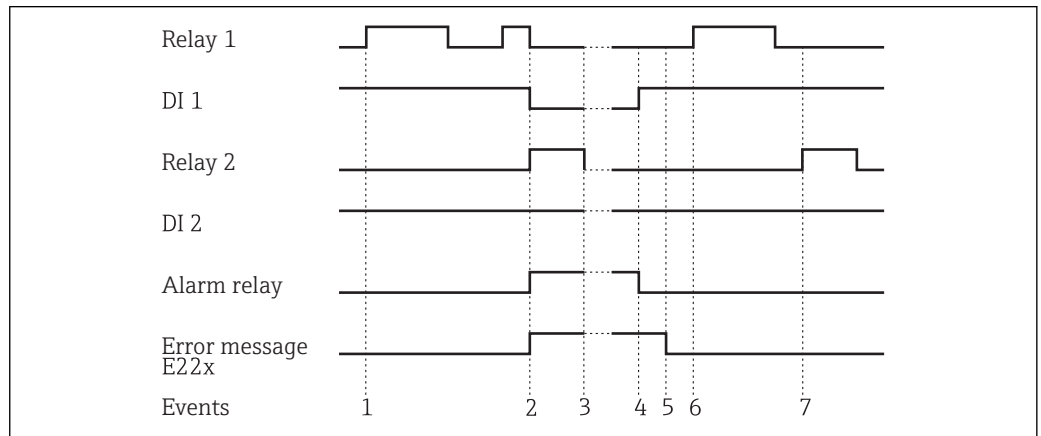

13 Fault monitoring operating mode

In event 1, pump 1 is requested due to limit value violation of the level. Pump 1 remains active until the level drops as much as required.

In event 2, a fault occurs at pump 1 during operation, status signal at DI1 changes. Pump 2 and the alarm relay are activated subsequently (if configured accordingly) and the pump fault is shown as a message on the display.

In event 3, the level has fallen so much that pumping is no longer necessary and pump 2 stops operation.

The fault at pump 1 was rectified, the status signal at DI1 changes once more. The alarm relay is reset, see event 4.

In event 5, the alarm relay and error message are acknowledged on the display by pressing the jog/shuttle.

Events 6 and 7 show uninterrupted operation of the system.

#### b) Startup monitoring

In the case of the startup monitoring operating mode, a change of the status signal is expected at the relevant digital input after a pump is activated. A waiting time is defined for this (Sampl. time, T). Alternating pump control is activated. If the signal does not change within the defined time, the pump is taken to be faulty.

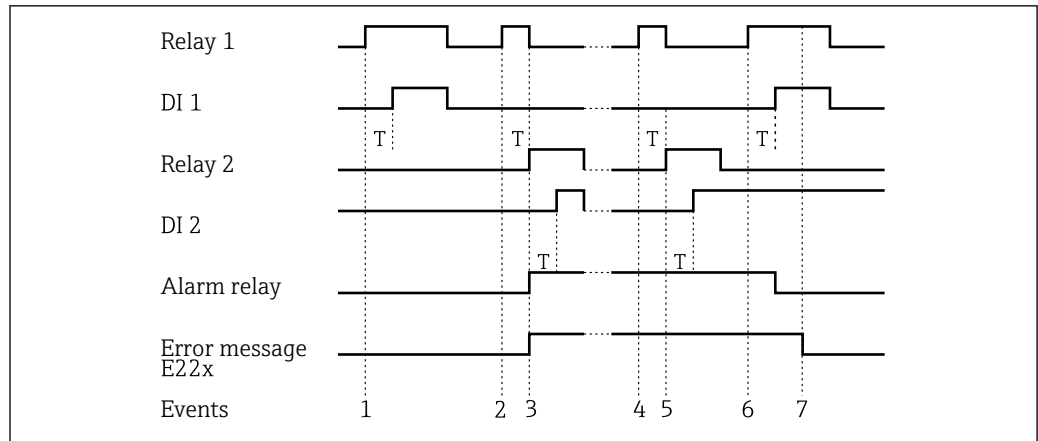

A0032766-EN

14 Startup monitoring operating mode

Event 1 shows uninterrupted operation of pump 1. Pump 1 is activated upon request due to a limit value violation. The status signal at DI1, which changes within T, indicates that the pump is operating correctly, pump 1 continues pumping.

In event 2, there is no feedback at DI1 after pump 1 is activated and thus this pump is taken to be faulty. The alarm relay is activated and an error message is output on the display.

Pump 2 takes over pumping, event 3. This pump provides feedback at DI2 within the defined waiting time. Pumping continues until the limit value violation is undershot.

A new limit value violation occurs in event 4. A new attempt is made to start pump 1 due to alternating pump control. Pump 2 takes over as, once more, there is no feedback after the waiting time elapses (event 5). If the alarm relay and error message were not already active on the display, they are now.

In event 6, the level is exceeded once more and a pump is requested. Following alternating pump control, pump 1 is tried again. This time, feedback is from pump 1. The alarm relay is reset.

In event 7, the error message is acknowledged on the display. The status signal at the DI has no effect on the acknowledgement of the error message on the display.

- i** In the PUMP function the assignment of the digital inputs 1..4 to the relays 1..4 is fixed. Relay 1 is monitored by digital input 1, relay 2 by digital input 2 and so on.
- A faulty pump is always restarted depending on the signal at the relevant digital input. Acknowledgement of the error message on the display has no effect on the pump resuming operation. If a pump is faulty for more than 10 minutes, an attempt is made to restart it when the limit value is violated.

The following parameters must be configured:

Menu	Function (menu item)	Setting value
DIGITAL INP./M5	Function	Pump
	Level	Low oder High
	Sampl. time	Sampling time in seconds
LIMIT 1...8	Alternate	Yes

### 7.3.5 Limit values - LIMIT 1...8/M10...17

- i** If the "Batch" function is used, limit values 1 and 2 are permanently assigned activation in the event of a "preset counter" and "preliminary alarm" limit value. These limit values cannot be configured. They are not shown in the menu structure.

Function (menu item)	Parameter setting	Description
Ref. num.	<b>Input</b> Lin. table	Selects which value is used: <ul style="list-style-type: none"> <li>Input: scaled value from analog input</li> <li>Lin. table: value from linearization table or current flow rate for calculation of channel</li> </ul>
Function	<b>Off</b> Min Max Grad In band Out band Alarm Alarm invers	Selects limit value and fault monitoring. In the event of device errors or incorrect input values (see error limits → 41), the relays are switched in accordance with the failsafe mode configured in Rel. Mode (→ 41). <ul style="list-style-type: none"> <li>Min: minimum with hysteresis → 28</li> <li>Max: maximum with hysteresis → 28</li> <li>Grad: gradient → 29</li> <li>In band: validity range within two values</li> <li>Out band: validity range outside of two values</li> <li>Alarm: relay is used as an alarm relay → 30</li> <li>Alarm invers: relay is used as an alarm relay; the relay behaves in a safety-oriented manner with the result that it is de-energized if the power supply fails or if the display unit has a fault.</li> </ul>
Dec. point	XXXXX <b>XXXX.X</b> XXX.XX XX.XXX X.XXXX	Number of digits after the decimal point for the limit value.
Setpoint A	-99999...99999 <b>0.0</b>	Measured value at which a change in the switch status occurs (slope for gradient).
Setpoint B	-99999...99999 <b>99999</b>	The second setpoint can be configured for the "In band" and "Out band" operating modes and is only visible if one of these two functions was selected for this relay.
Hysteresis	-99999...99999 <b>99999</b>	For entering the hysteresis for the threshold at minimum/maximum as an absolute value.
Delay	0...99 <b>0</b>	Sets the limit value event delay once the threshold is reached (in seconds) → 30.
Alternate	<b>No</b> Yes	Determines the switching function for this relay: <ul style="list-style-type: none"> <li>No: no alternating function; switch point permanently assigned to relay</li> <li>Yes: alternate function → 31</li> </ul> Relays 1-4 can be used for the alternate function.
Sw. delay	0...99 <b>0</b>	The starting time for 24-hour counting can be selected with Sw. delay. Every time the instrument is reset, the process of measuring 24 hours and the delay time is restarted. Example → 32
Sw. period	0...999 <b>0</b>	Limit value is activated cyclically every 24 h for 0 to 999 s. The activation is delayed by [Sw.delay] hours by changing the hour value (example → 32).
Runtime		Displays the run time of the connected device, e.g. pump, in hours [h].
Count		Records the switching frequency of the limit value.
Reset	<b>No</b> Yes	Resets the run time and switching frequency for this limit value.
Simu Relais	<b>Off</b> Low High	Simulation of the selected limit value. Is automatically set to Off when the menu item is exited.

### Min operating mode

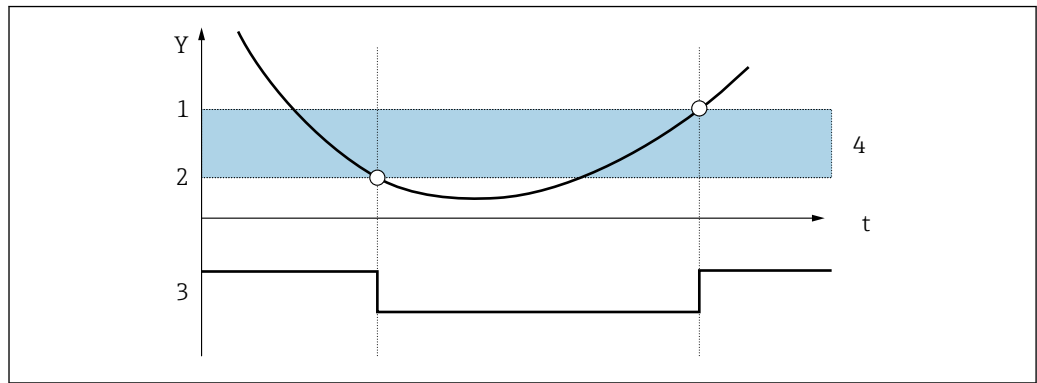

A0032767

15 Min operating mode

- $Y$  Measured value
- $t$  Time
- 1 Threshold + hysteresis
- 2 Threshold
- 3 Relay
- 4 Hysteresis

Folgende Parameter müssen eingestellt werden:

Menu	Function (menu item)	Setting value
LIMIT 1...8/M10...17	Function	Min
	Setpoint A	Value for threshold
	Hysteresis	Value for hysteresis

### Max operating mode

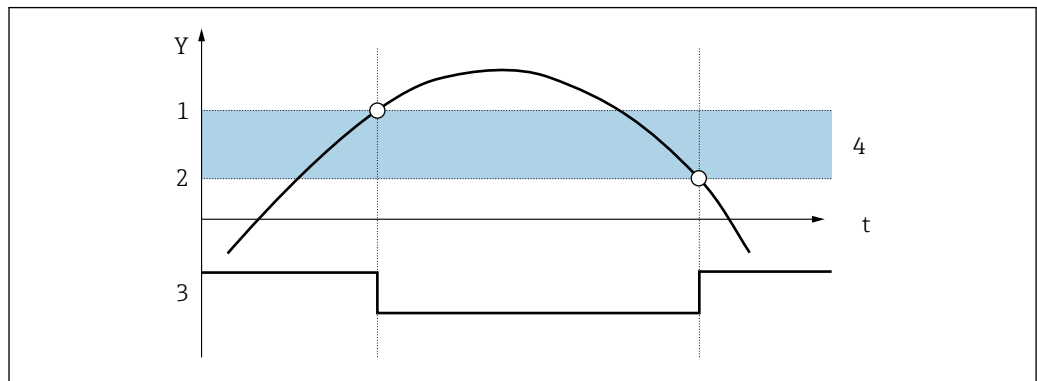

A0032768

16 Max operating mode

- $Y$  Measured value
- $t$  Time
- 1 Threshold
- 2 Threshold - hysteresis
- 3 Relay
- 4 Hysteresis

The following parameters must be configured:

Menu	Function (menu item)	Setting value
LIMIT 1...8/M10...17	Function	Min
	Setpoint A	Value for threshold
	Hysterese	Value for hysteresis

**Grad operating mode**

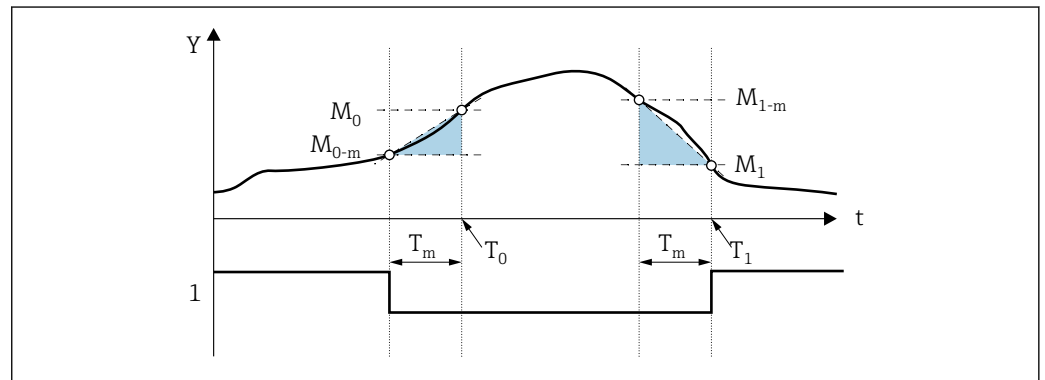

17 Grad operating mode

- Y Measured value
- t Time
- T<sub>m</sub> Time for gradient evaluation
- M<sub>0</sub> Measured value at time T<sub>0</sub>
- M<sub>0-m</sub> Measured value at time (T<sub>0</sub>-T<sub>m</sub>)
- M<sub>1</sub> Measured value at time T<sub>1</sub>
- M<sub>1-m</sub> Measured value at time (T<sub>1</sub>-T<sub>m</sub>)
- 1 Relay

The "Grad" operating mode is used for monitoring the changes in the input signal over time. The time basis T<sub>m</sub> of the monitoring system is configured in the "PARAMETER/M55 -> Grad. time" menu.

The difference between the lower range value M<sub>0-m</sub> and the upper range value M<sub>0</sub> of the interval is calculated. If the calculated value is greater than the value set under "Setpoint A", the relay is switched in accordance with the failsafe mode configured in "Rel. Mode" (→ 41).

The relay is switched on again once the difference between M<sub>1-m</sub> and M<sub>1</sub> drops below the value set in "Hysteresis". The sign determines the direction of signal change. Positive values monitor an increase in the measured value while negative values monitor a decrease. A new value is calculated every second (floating interval).

The following parameters must be configured:

Menu	Function (menu item)	Setting value
LIMIT 1..8/M10...17	Function	Min
	Setpoint A	Gradient value for threshold
	Hysterese	Value for hysteresis
	Grad. time	Interval time in seconds

### Alarm operating mode

A relay with the "Alarm" operating mode is activated if the following events occur:

- Analog input (4 to 20 mA) < 3.6 mA (lower Namur limit) or > 21.0 mA (upper Namur limit)
- EEPROM HW error (E101)  
The relay remains picked up even after acknowledging.
- Implausible calibration data (E103)  
The relay remains picked up even after acknowledging.
- Bus error reading the min/max data after power-up (E104)  
The relay remains picked up even after acknowledging.
- Bus error reading the relay data after power-up (E105)  
The relay remains picked up even after acknowledging.
- Universal card HW error (E106)  
The relay remains picked up even after acknowledging.
- Pulse buffer overflow (E210)  
The relay is de-energized after acknowledgement.
- Pump error at the digital input x in question (E22x)  
The relay remains picked up even after acknowledging.

### Delay

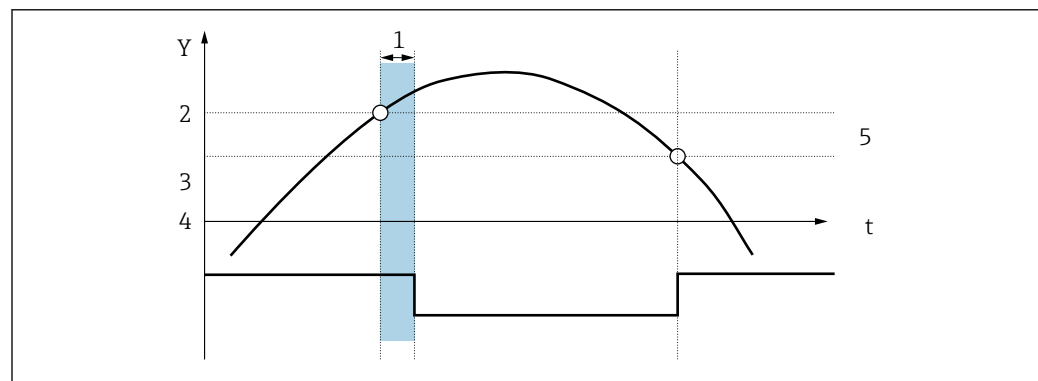

A0032770

#### 18 Delay

- Y Measured value  
t Time  
1 Delay  
2 Threshold Max  
3 Threshold - hysteresis  
4 Relay  
5 Hysteresis

The following parameters must be configured:

Menu	Function (menu item)	Setting value
LIMIT 1...8/M10...17	Setpoint A	Value for threshold
	Hysteresis	Value for hysteresis
	Delay	Delay time in [s]

Alternate

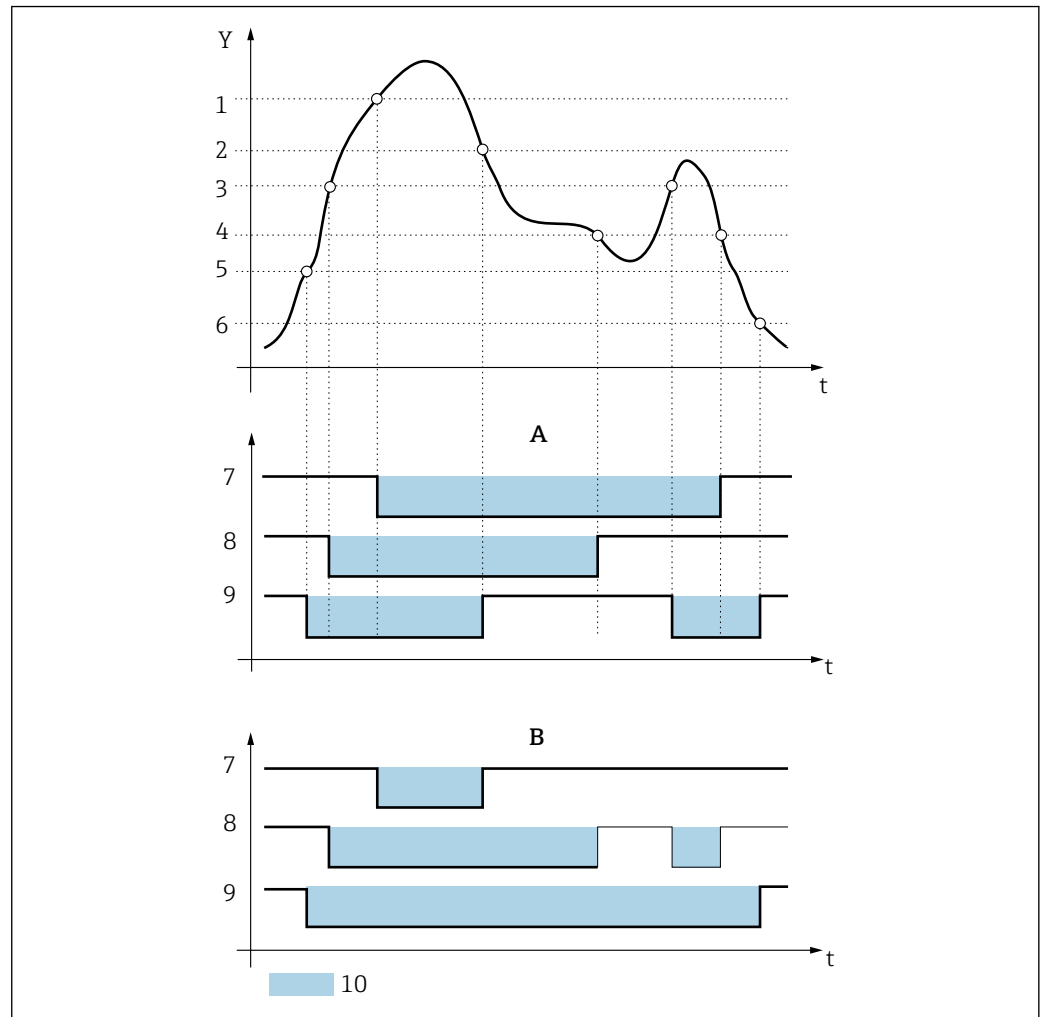

A0032771

19 Alternating pump control

- A With alternating pump control
- B Without alternating pump control

Y	Measured value	3	Setpoint A2	7	Relay 3 switching state
t	Time	4	Setpoint A2 - hysteresis 2	8	Relay 2 switching state
1	Setpoint A3	5	Setpoint A1	9	Relay 1 switching state
2	Setpoint A3 - hysteresis 3	6	Setpoint A1 - hysteresis 1	10	Relay de-energized

Alternate switching is used to ensure that several pumps are utilized evenly in level control systems. The main factor for switching on a certain pump is not a fixed assigned switch-on value but rather the operating time of the pumps.

In total, the first 4 relays (LIMIT 1 to 4) can be included in the alternating pump control system.

**i** Relays not included in alternating pump control are available.

This function cannot be applied to individual relays. Relays not included are not assessed based on the switch-on and switch-off duration.

The following parameters must be configured for the example above:

Menu	Function (menu item)	Setting value
LIMIT 1...3/M10...12	Each: Setpoint A	Value for threshold
	Each: Hysteresis	Value for hysteresis
	Each: Alternate	Yes

### 24-hour activation function

Pumps with long downtimes can be activated cyclically with the 24-hour activation function for the time defined in "Sw. period" (0 to 999 s).

The starting time for the 24 h step interval can be postponed by 0 to 23 hours with the "Sw. delay" setting.

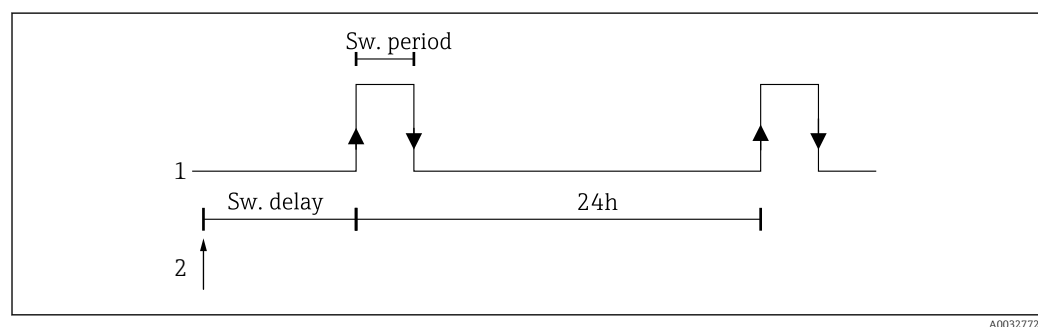

20 24-hour activation function

- 1 Relay
- 2 Start

Example: time at the time of configuration 12 midday, desired start of 24-hour counting 22:00 (10 p.m.) → set "Sw. delay" to 10.

**i** If power is switched off, the time for the 24-hour activation function starts again.

The following parameters must be configured for the example above:

Menu	Function (menu item)	Setting value
LIMIT	Sw. period	Activation duration
	Sw. delay	Activation delay

### 7.3.6 Integration - INTEGRATION/M18

**i** If the preset counter function ("Batch") is used, digital input 1 and relay 1 and 2 are permanently assigned to this function. Configuration for these inputs/outputs is then not possible.



This function can only be selected if the pulse output option is available in the device.

Funktion (Menüposition)	Parameter setting	Description
Ref. integr.	<b>Input</b> Lintab	Selects which value should be integrated. <ul style="list-style-type: none"> <li>Input = measured value</li> <li>Lintab = linearized measured value or current flow rate for calculation of channel</li> </ul>
Pre-counter	<b>Off</b> Count up Count down	Activation of the preset counter <ul style="list-style-type: none"> <li>Off = preset counter off</li> <li>Count up = counting up from zero to the end value</li> <li>Count down = counting down from the start value to zero</li> </ul>
Integr. base	<b>Off</b> sec min hour day	Time basis for integration
Dec. factor	XXXXX XXXX.X XXX.XX XX.XXX X.XXXX	Decimal point position of the conversion factor
Factor	0..99999 1.0	Conversion factor
Dimension	XXXXXXXXXX	Select the dimension from the list or dimension as free text (max. 9 characters long).
Dec. Point T	XXXXX XXXX.X XXX.XX XX.XXX X.XXXX	Decimal point of totalizer
Set count A	99999 0.0	End value/start value for preset counter; refers permanently to relay 1.
Set count B	99999 0.0	Value for preliminary alarm; refers permanently to relay 2.
Totalizer	9999999	In this position, the totalizer can be displayed and edited (e.g. assigned a default value). The counter starts again at 0 if the maximum value of 9999999 is exceeded.
Reset Total	<b>No</b> Yes	Reset totalizer Cannot be configured via the PC operating software.
Calc. Flow	<b>No</b> Curve Formula	For selecting a method of calculating the total flow based on the channel type or by means of a formula using the analog input signal (e.g. level signal) <ul style="list-style-type: none"> <li>No = no integration</li> <li>Curve = flow calculated with channel type. If "Curve" is selected, the menu only displays possible channel types for configuration (e.g. Venturi channels, Parshall channels, weirs etc.)</li> <li>Formula = flow calculated using a formula. If "Formula" is selected, the menu only displays possible configuration parameters for entering the formula (Alpha, Beta, Gamma, C). Here, the flow is calculated using the following formula: <math>Q = C * (h^\alpha + \gamma * h^\beta)</math></li> </ul>
Dim. Input	<b>mm</b> inch	Dimension of the channel size

Funktion (Menüposition)	Parameter setting	Description
Dec. flow	XXXXX XXXX.X XXX.XX XX.XXX X.XXXX	Decimal point for display
Dim. flow	m <sup>3</sup> /s, l/s, hl/s, igal/s, usgal/s, barrels/s, inch <sup>3</sup> /s, ft <sup>3</sup> /s, Usmgal/s, Ml/s, m <sup>3</sup> /smin, l/ min, hl/min, igal/ min, usgal/ min, barrels/min, inch <sup>3</sup> / min, ft <sup>3</sup> / min, Usmgal/ min, Ml/min, m <sup>3</sup> /h, l/ h, hl/h, igal/h, usgal/h, barrels/h, inch <sup>3</sup> /h, ft <sup>3</sup> /h, Usmgal/h, Ml/h	Dimension of linearized value <ul style="list-style-type: none"> <li>■ l = liter</li> <li>■ hl = hectoliter</li> <li>■ m<sup>3</sup> = cubic meter</li> <li>■ Ml = megaliter</li> <li>■ USgal = US gallon</li> <li>■ USKgal = US kilogallon</li> <li>■ USMgal = US megagallon</li> <li>■ USbl = US barrel</li> <li>■ igal = imperial gallon</li> <li>■ ibl = imperial barrel</li> <li>■ inch = inch</li> <li>■ ft = feet</li> </ul>
Dec. point	XXXXX XXXX.X XXX.XX XX.XXX X.XXXX	Decimal point for formula (only if formula-based flow calculation is selected)
Alpha	-99.99999	Flow rate exponent $\alpha$ (see "Calc.flow")
Beta	-99.99999	Flow rate exponent $\beta$ (see "Calc.flow")
Gamma	-99.99999	Weighting factor $\gamma$ (see "Calc.flow")
C	-100	Scaling constant C (see "Calc.flow")
Flumes Weir	Kha Venturi ISO Venturi BST Venturi Parshall Palmer-Bow Rect. WTO Rect WThr NFXRectWTO NFXRectWThr Trap.W TO V-weir BST V-weir NFX V-weir	Kha-Venturi = Khafagi-Venturi channels ISO Venturi = ISO-Venturi channels BST Venturi = Venturi channels as per British Standard Parshall = Parshall channels Palmer-Bow = Parshall-Bowlus channels Rect. WTO = Rectangular weir (w) Rect WThr = Rectangular weir with constriction (w) NFXRectWTO = Rectangular weir as per NFX (w) NFXRectWThr = Rectangular weir as per NFX with constriction (w) Trap.WTO = Trapezoidal weir (w) V-weir = Triangular weir (w) BST V-weir = Triangular weir as per British Standard NFX V-weir = Triangular weir as per NFX  Configure (w) width additionally
Width	99999	Value for width. Can only be selected for channel types marked with (w) (see "Flumes-Weir")
Kha-Venturi	QV 302 QV 303 QV 304 QV 305 QV 306	Khafagi-Venturi channels QV 302 = Khafagi-Venturi channel QV 302 QV 303 = Khafagi-Venturi channel QV 303 QV 304 = Khafagi-Venturi channel QV 304 QV 305 = Khafagi-Venturi channel QV 305 QV 306 = Khafagi-Venturi channel QV 306

Funktion (Menüposition)	Parameter setting	Description
	QV 308 QV 310 QV 313 QV 316	QV 308 = Khafagi-Venturi channel QV 308 QV 310 = Khafagi-Venturi channel QV 310 QV 313 = Khafagi-Venturi channel QV 313 QV 316 = Khafagi-Venturi channel QV 316
ISO Venturi	415 425 430 440 450 480	ISO-Venturi channels 415 = ISO-Venturi channel 415 425 = ISO-Venturi channel 425 430 = ISO-Venturi channel 430 440 = ISO-Venturi channel 440 450 = ISO-Venturi channel 450 480 = ISO-Venturi channel 480
BST Venturi	4" 7" 12" 18" 30"	Venturi channels as per British Standard 4" = Venturi channel as per British Standard 4 in 7" = Venturi channel as per British Standard 7 in 12" = Venturi channel as per British Standard 12 in 18" = Venturi channel as per British Standard 18 in 30" = Venturi channel as per British Standard 30 in
Parshall	1" 2" 3" 6" 9" 1 ft 1.5 ft 2 ft 3 ft 4 ft 5 ft 6 ft 8 ft	Parshall channels 1" = Parshall channel 1 in 2" = Parshall channel 2 in 3" = Parshall channel 3 in 6" = Parshall channel 6 in 9" = Parshall channel 9 in 1 ft = Parshall channel 1 ft 1.5 ft = Parshall channel 1,5 ft 2 ft = Parshall channel 2 ft 3 ft = Parshall channel 3 ft 4 ft = Parshall channel 4 ft 5 ft = Parshall channel 5 ft 6 ft = Parshall channel 6 ft 8 ft = Parshall channel 8 ft
Palmer-Bowl.	6" 8" 10" 12" 15" 18" 21" 24" 27" 30"	Palmer-Bowlus channels 6" = Palmer-Bowlus channel 6 in 8" = Palmer-Bowlus channel 8 in 10" = Palmer-Bowlus channel 10 in 12" = Palmer-Bowlus channel 12 in 15" = Palmer-Bowlus channel 15 in 18" = Palmer-Bowlus channel 18 in 21" = Palmer-Bowlus channel 21 in 24" = Palmer-Bowlus channel 24 in 27" = Palmer-Bowlus channel 27 in 30" = Palmer-Bowlus channel 30 in

Funktion (Menüposition)	Parameter setting	Description
Rect.WTO	5H	Rectangular weirs 5H = Rectangular weir WTO/5H
	T5	T5 = Rectangular weir WTO/T5
Rect.WThr	2H	Rectangular weirs with constriction 2H = Rectangular weir with constriction 2H
	3H	3H = Rectangular weir with constriction 3H
	4H	4H = Rectangular weir with constriction 4H
	5H	5H = Rectangular weir with constriction 5H
	6H	6H = Rectangular weir with constriction 6H
	8H	8H = Rectangular weir with constriction 8H
	TO	TO = Rectangular weir with constriction TO
	T5	T5 = Rectangular weir with constriction T5
NFXRect.WTO	5H	Rectangular weir NFX 5H = NFX Rectangular weir TO/5H
	T5	T5 = NFX Rectangular weir TO/T5
NFXRect.WThr	2H	Rectangular weir NFX with constriction 2H = NFX Rectangular weir with constriction 2H
	3H	3H = NFX Rectangular weir with constriction 3H
	4H	4H = NFX Rectangular weir with constriction 4H
	5H	5H = NFX Rectangular weir with constriction 5H
	6H	6H = NFX Rectangular weir with constriction 6H
	8H	8H = NFX Rectangular weir with constriction 8H
	TO	TO = NFX Rectangular weir with constriction TO
Trap. W TO	3H	Trapezoidal weirs 3H = Trapezoidal weir W TO/3H
	T5	T5 = Trapezoidal weir W TO/T5
V-weir	22.5	Triangular weirs 22.5 = Triangular weir 22.5
	30	30 = Triangular weir 30
	45	45 = Triangular weir 45
	60	60 = Triangular weir 60
	90	90 = Triangular weir 90
BST V-weir	22.5	Triangular weir as per British Standard 22.5 = Triangular weir as per British Standard 22.5
	45	45 = Triangular weir as per British Standard 45
	90	90 = Triangular weir as per British Standard 90
NFX V-weir	30	NFX Triangular weirs 30 = NFX Triangular weir 30
	45	45 = NFX Triangular weir 45
	60	60 = NFX Triangular weir 60
	90	90 = NFX Triangular weir 90

### Calculation formula for flow measurement

If you selected "Formula" under "Calc. flow" for flow measurement, the flow is calculated using the following formula:

$$Q = C * (h^{\alpha} + \gamma * h^{\beta})$$

Where:

- Q: Flow rate in m<sup>3</sup>/h
- C: Scaling constant
- h: Headwater level
- α, β: Flow exponent
- γ: Weighting factor

 The scaling constant C must always refer to Q in m<sup>3</sup>/h, i.e. C has to be converted if Q is available in another flow unit.

Examples:

- Q in l/h with C = 2.11  
1 l/h = 0.001 m<sup>3</sup>/h  
→ C = 2.11 \* 0.001 = 0.00211
- Q in USKgal/s with C = 0.35  
1 USKgal/s = 13 627.4444 m<sup>3</sup>/h  
→ C = 0.35 \* 13 627.4444 = 4 769.60554

A table with values for converting the various flow units to m<sup>3</sup>/h is provided in the appendix.

### Integration function/totalizer

With this function, the computed value from the linearization table, or of the current flow rate for channel calculation or of the analog input can be numerically integrated to create a totalizer for example.

The totalizer is calculated as follows:

$$\text{Totalizer}_{\text{new}} = \text{Totalizer}_{\text{old}} + \text{value} * \frac{\text{measuring interval}}{\text{integration base}} * \text{conversion factor}$$

The measuring interval is 0.1 s.

In most instances, the integration basis is the same time unit as the time basis of the signal to be integrated.

Example: analog input l/s → integration base s !

### Simple preset counter

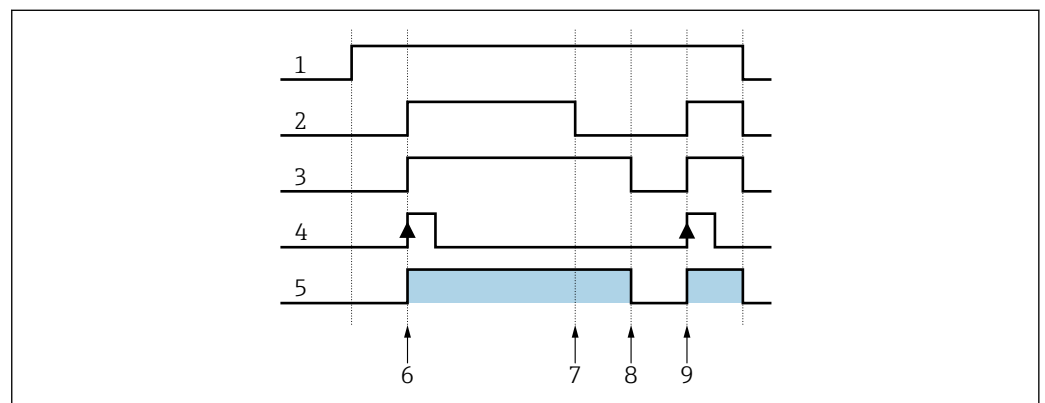

 21 Simple preset counter

A0032773

1	Power on	4	Digital input 1	7	Limit value B
2	Relay 2	5	Counter run time	8	Limit value A
3	Relay 1	6	Restart counter	9	Restart counter

If the preset counter is activated, limit values 1 and 2 are permanently assigned to the preset counter function (output 1 = main switchoff, output 2 = preliminary switchoff). Digital input 1 is permanently assigned to the "Reset and restart preset counter" function.

Thus, the number of free relays available is reduced accordingly. The operating menus for these inputs/outputs are then hidden.

"Set count B" (limit value B) defines the preliminary switchoff, "Set count A" (limit value A) defines the main switchoff. Limit value (or start value, see "Pre-counter" function →  32) for limit value A and preliminary alarm value for limit value B are freely configurable.

The positive counting direction is defined as follows: starting at the fixed starting value of zero, count up until the set limit value is reached ("Set count A").

The negative counting direction is defined as follows: starting at the configurable starting value ("Set count A"), count down until the fixed limit value of zero is reached.

The counter is reset and restarted at the same time by means of digital input 1 ("Digital Inp.1"). Edge "Digital Inp.1": Low-High = reset and start counter.

 The display of the preset counter can be configured under DISPLAY/M2 → "Ref.num" = "Batch".

### 7.3.7 Pulse output - PULSE OUT/M19

All the possible settings for the pulse output can be found in this menu item. This menu item can only be selected if your device is fitted with this option.

Function (menu item)	Parameter setting	Description
Dec. value	XXXXX XXXX.X XXX.XX XX.XXX X.XXXX	Decimal point position of the pulse value.
Unit value	0..99999 1.0	Pulse value with which the pulses should be output at the output.
Pulse width	0.04 .. 2000ms 1000.00	Sets the pulse width at the pulse output. The maximum output frequency depends on the pulse width. $f(\max) = 1/(2 * \text{pulse width})$
Sim pulseout	Off 1 Hz 10 Hz 100 Hz 1000 Hz 10000 Hz	Outputs the selected pulses at the pulse output regardless of the input value. Is automatically set to OFF when exited.

### 7.3.8 Min/Max memory - MIN MAX/M20

The panel meter can save a minimum and a maximum measured value. The input signal or the signal processed using the linearization table are available as the signal source. The memory is reset manually or using the digital input (→  24).

Function (menu item)	Parameter setting	Description
Ref. Min/Max	<b>Input</b> Lintab	Signal source for the min/max value memory. <ul style="list-style-type: none"> <li>Input = input signal</li> <li>Lintab = linearized input signal or current flow rate for calculation of channel</li> </ul>
Dec. point	XXXXX XXXX.X XXX.XX XX.XXX X.XXXX	Number of digits after the decimal point for the min/max value memory.
Min. value	0...99999	Displays the current minimum value in the memory.
Max. value	0...99999	Displays the current maximum value in the memory.
Reset min	<b>No</b> Yes	Resets the minimum value memory.
Reset Max	<b>No</b> Yes	Resets the maximum value memory.

### 7.3.9 Linearization table - LIN. TABLE/M21

To linearize input variables, a linearization table can be saved in the measuring instrument, e.g. to correct the level signal of a container for volume display.

Function (menu item)	Parameter setting	Description
Counts	2...32 2	Number of support points needed. At least two points have to be entered.
Dimension	XXXXXXXXXX	Select the dimension from the list or dimension as free text (max. 9 characters long).
Dec. Y value	XXXXX XXXX.X XXX.XX XX.XXX X.XXXX	Decimal point position for the Y-values in the linearization table.
Del. points	<b>No</b> Yes	Delete all programmed support points.
Show points	<b>No</b> Yes	Show all programmed support points.

**Tank linearization**

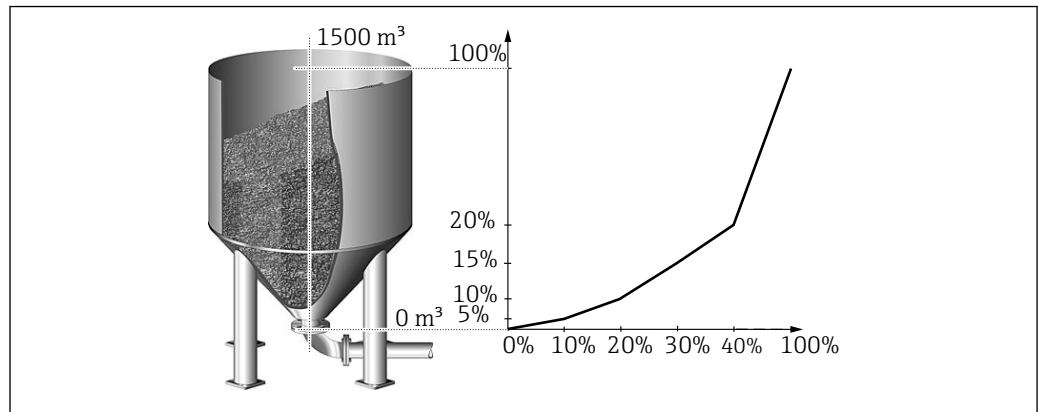

22 Example for tank linearization

You want to determine the amount of cereal filled into a silo, display this information on site and transfer it to a process control system. A 4 to 20 mA level sensor determines the level in the container, the connection between the level (m) and volume (m<sup>3</sup>) is known and the level is proportional to the sensor current. The volume calculated is output as a 0 to 20 mA signal at the analog output in proportion to the volume. In the event of a fault in the system, the analog output outputs an error signal of 21.0 mA.

- Container empty:
  - Sensor signal 4 mA
  - Level 0 m
  - Numeric display should show 0 (m<sup>3</sup>)
  - Bar graph should show 0%
  - 0 mA should be present at the analog output
- Container full:
  - Sensor signal 20 mA
  - Level 10 m
  - Numeric display should show 1500 (m<sup>3</sup>)
  - Bar graph should show 100%
  - 20 mA should be present at the analog output

	Point									
	1	2	3	4	5	6	7	8	9	10
Sensor signal (mA)	X value 4.0	X value 4.32	X value 4.64	X value 4.96	X value 5.28	X value 5.6	X value 5.92	X value 6.24	X value 6.56	X value 20
Display value (m <sup>3</sup> )	Y value 0	Y value 20	Y value 50	Y value 85	Y value 115	Y value 160	Y value 210	Y value 280	Y value 400	Y value 1500

The following parameters must be configured for the example above:

Menu	Function (menu item)	Setting value
LIN. TABLE / M 21	Counts	Number of support points (10)
	Dimension	Dimension of linearized value (m <sup>3</sup> )
	Show points	Display support points (Yes)
LINPOINTS 1...10 / M23...32	Each point	Use point (Used)
	Each X value	X-value (as in table above)
	Each Y value	Y-value (as in table above)



Menu	Function (menu item)	Setting value
ANALOG OUT / M 3	Ref. num	Output value (Lintab)
	Out range	Signal type (0-20 mA)
	Fail mode	Failsafe mode (Const)
	Fail value	Value in event of error (21.0 mA)
DISPLAY / M 2	Ref. num.	Reading on display (LIN. TABLE)
	Ref. bargraf	Signal source for bar graph (Lintab)

 The PC operating software supports the generation of a tank linearization table. Here you can find a tank linearization generator which you can use to generate a linearization table for standard and specific tanks.

### 7.3.10 Support points of linearization table - LINPOINTS 1.X/M23..MXX

Displays the set value pairs of the linearization table. This menu item is only visible if a linearization table was configured (→  39) and "Yes" was selected in the "Show points" parameter in the "LIN. TABLE/M21" menu.

Function (menu item)	Parameter setting	Description
Point	<b>Used</b> Discard	Use or discard support point.
X value	-99999...99999	X-value of the linearization table. Corresponds to the input value.
Y value	-99999...99999	Y-value that belongs to the previous X-value. Corresponds to the converted measured value.

### 7.3.11 Operating parameters - PARAMETER/M55

In this menu item, configuration options such as the user code, failsafe mode of the panel meter to NAMUR etc. can be configured.

Function (menu item)	Parameter setting	Description
User code	9999	The option of editing the operating parameters is locked after entering a 4-digit digital sequence. This lock is indicated on the display with the "key" symbol.
Limit code	<b>Off</b> On	<ul style="list-style-type: none"> <li>▪ Off: It is not necessary to enter the user code to change the limit values</li> <li>▪ On: Limit values are protected by the user code.</li> </ul> The item is only displayed if a user code was assigned.
Prog. name	ILU10xA	Displays the name of the device software currently installed.
Version	V X.XX.XX	Version of the device software currently installed.
Func. alt.	<b>Time</b> Count	Setting for controlling pump rotation in alternating pump control. <ul style="list-style-type: none"> <li>▪ Time = switching time of the relay</li> <li>▪ Count = switching frequency of the relay</li> </ul>
Lock time	99.9	Locking time of the relay, 0 to 99.9 s

Function (menu item)	Parameter setting	Description
Rel. Mode	<b>Off</b> On	Switching mode of the relays. <ul style="list-style-type: none"> <li>■ Off = relays de-energize in the event of limit value violation</li> <li>■ On = relays energize in the event of limit value violation</li> </ul>
Grad. Time	1...100	Time setting for gradient evaluation, 1 to 100 s
Namur	<b>No</b> Yes	Sensor evaluation to NAMUR (e.g. cable open circuit). Only for 4 to 20 mA current signal.
Range 1	0.0...22.0 3.6 (NAMUR)	Error limits for the input signal. In the "NAMUR=Yes" operating mode, ranges 1 to 4 are assigned the limits specified by Namur NE 43 and cannot be changed. In the "NAMUR=No" operating mode, the error limits can be freely selected. Here, please note that the following applies: Range 1 < Range 2 < Range 3 < Range 4. Violation of these limits can be evaluated with a relay for example ("Alarm" and "Alarm inverse" operating mode).
Range 2	0.0...22.0 3.8 (NAMUR)	
Range 3	0.0...22.0 20.5 (NAMUR)	
Range 4	0.0...22.0 21.0 (NAMUR)	
Contrast	1...30	Setting for the display contrast. <ul style="list-style-type: none"> <li>■ 1 = low contrast</li> <li>■ 30 = high contrast</li> </ul>



## 8 Maintenance

No special maintenance work is required on the device.

## 9 Accessories

Various accessories, which can be ordered with the device or subsequently from Endress+Hauser, are available for the device. Detailed information on the order code in question is available from your local Endress+Hauser sales center or on the product page of the Endress+Hauser website: [www.endress.com](http://www.endress.com).

### 9.1 Device-specific accessories

Designation	Order no.
PC configuration software ReadWin 2000 and serial configuration cable with jack connector 3.5 mm for RS232 port	RIA452A-VK
PC configuration software ReadWin 2000 and serial configuration cable for USB-port with CDI connector	TXU10-AA
Field housing IP65 →  23,  43	51009957
Current simulator active 4-20mA 1-channel, compact housing, 9V-battery	SONDST-S1

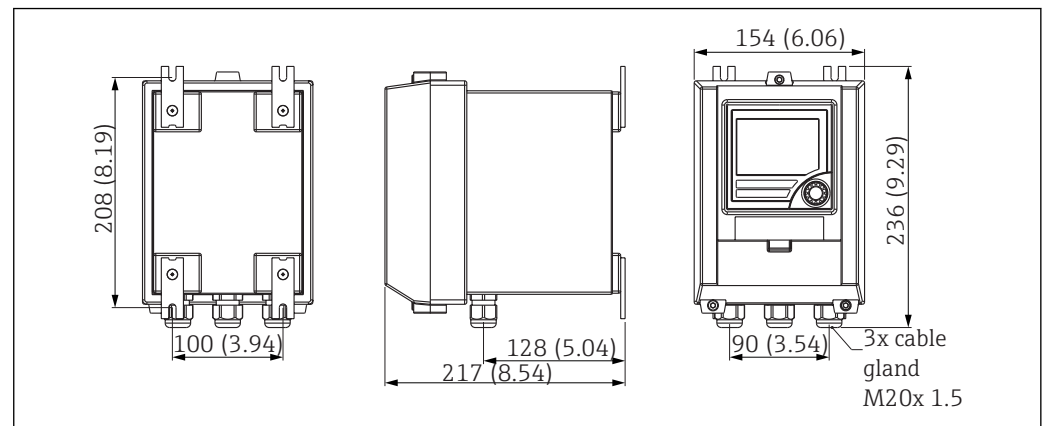

A0033026

 23 Dimensions of field housing

# 10 Troubleshooting



## 10.1 Troubleshooting instructions

**NOTICE**

**Explosion hazard through open device in explosion-hazardous environment**

- ▶ In the case of Ex devices, fault diagnosis cannot be carried out on the open device as this annuls the explosion protection.

Display	Cause	Remedy
No measured value display	No power supply connected	Check the power supply of the device.
	Power supply applied, device defective	The device must be replaced.
The red marking for overrange/ underrange is flashing on the bar graph.	Analog output is > 10% above or below the scaled range.	Check the scaling of the analog output (Out 100% or Out 0%).

 Errors for which an error code is shown on the display are described in the following section →  44 beschrieben.

Further information on the display is also provided in the section "Display" →  15.

## 10.2 Process error messages

 Faults have the highest priority. The associated error code is displayed. A fault is present if the memory module for writing and reading data is defective or if data could not be read correctly.

### 10.2.1 Device malfunction

Error code	Cause	Effect	Remedy
E 101	Bus error reading the config/ calibration data after power-up	Faulty device functioning	Instrument error, notify Service
E 102	Implausible operating data (checksum)	Configuration lost	Perform preset
E 103	Implausible calibration data	Faulty device functioning	Instrument error, notify Service
E 104	Bus error reading the min/ max data after power-up	Incorrect min/max values	Reset min/max values
E 105	Bus error reading the relay data after power-up	Incorrect relay data	Reset relay data
E 106	Universal card bus error	Faulty universal input functioning	Replace universal card, notify Service
E 210	Pulse output Pulse buffer overflow	A maximum of 10 pulses are buffered	Set the parameters of the pulse output in such a way that the maximum frequency is not exceeded
E 221	Pump error Digital input 1	Relay goes to failsafe mode	Acknowledge error via operation or switching power on/off
E 222	Pump error Digital input 2		
E 223	Pump error Digital input 3		

Error code	Cause	Effect	Remedy
E 224	Pump error Digital input 4		
E 290	Number overshoot due to decimal point shift	Decimal point position cannot be altered	Check decimal point position and number range

**i** The errors listed above can be evaluated with a relay in the "Alarm" and "Alarm inverse" operating mode.

### 10.2.2 Incorrect entries

Error code	Description	Reaction at device
E 290	The number of digits after the decimal point cannot be increased due to number overflow of the dependent parameters.	Error code is shown on the display until a key is pressed.

### 10.2.3 Spare parts

Specify the device serial number when ordering spare parts!

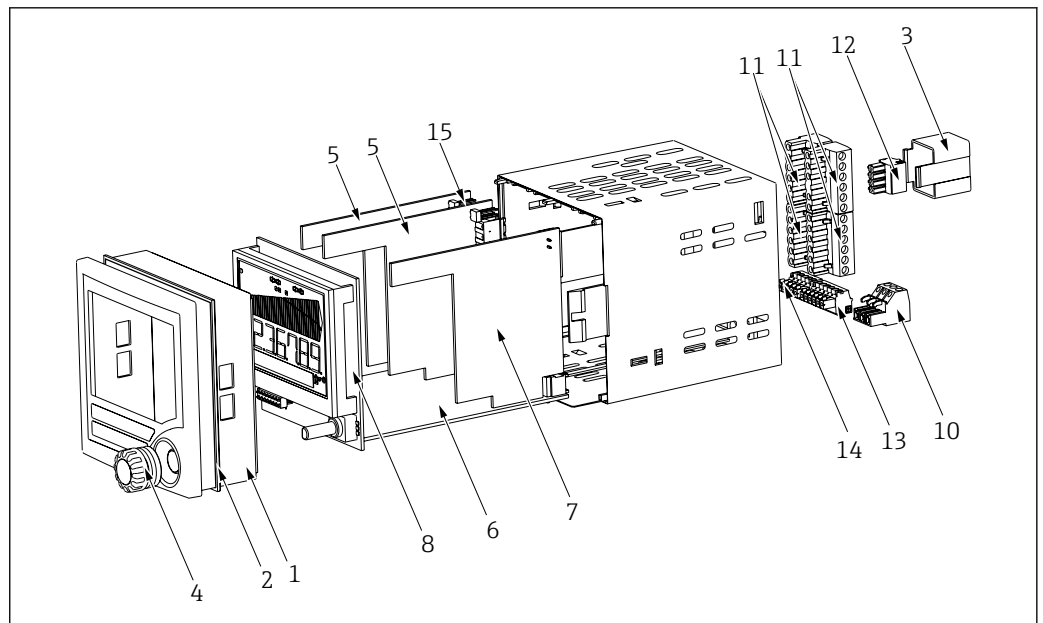

A0032775

**24** Spare parts of the process indicator

Item No.	Name	Order No.
1	Housing front	RIA452X-HA
2	Housing seal	50070730
3	Ex-cover (rear panel)	51008272
4	Rotary button with seal	RIA452X-HB
5	Relay board	RIA452X-RA
6	Mainboard 90 to 250 V, 50/60 Hz	RIA452X-MA
	Mainboard 20 to 36 V DC; 20 to 28 V AC, 50/60 Hz	RIA452X-MB
	Mainboard 90 to 253VAC + analog output	RIA452X-MC
	Mainboard 10 to 36VDC/20 to 27VAC + analog output	RIA452X-MD

Item No.	Name	Order No.
	Mainboard 90 to 253VAC + integration + pulse output	RIA452X-ME
	Mainboard 10 to 36VDC/20 to 27VAC + integration + pulse output	RIA452X-MF
	Mainboard 90 to 253VAC + output + integr. (pulse + analog output)	RIA452X-MG
	Mainboard 10 to 36VDC + output + integr. (pulse + analog output)	RIA452X-MH
7	Standard input card	RIA452X-IA
	Standard input card ATEX, FM, CSA approval	RIA452X-IB
	Multifunction input card	RIA452X-IC
8	Complete display board	RIA452X-DA
10	Terminal (power supply) 3-pin	50078843
11	Terminal (relay 1-8) 6-pin	51005104
12	Terminal (analog input) 4-pin	51009302
13	Terminal (analog output, Open Collector, transmitter power supply) 6-pin	51008588
14	Terminal (digital inputs) 5-pin	51008587
15	Jumper operating lock	50033350
o. Nr.	Casing fixing clip RIA452 (1 piece)	71035359

## 11 Return

The measuring device must be returned if it is need of repair or a factory calibration, or if the wrong measuring device has been delivered or ordered. Legal specifications require Endress+Hauser, as an ISO-certified company, to follow certain procedures when handling products that are in contact with the medium.

To ensure safe, swift and professional device returns, please refer to the procedure and conditions for returning devices provided on the Endress+Hauser website at <http://www.endress.com/support/return-material>

## 12 Disposal

The device contains electronic components and must therefore be disposed of as electronic waste. Comply with local disposal regulations.

## 13 Technical data

### 13.1 Input

#### 13.1.1 Measured variable

- Current (standard)
- Digital inputs (standard)
- Current/voltage, resistance, resistance thermometer, thermocouples (universal input option)

#### 13.1.2 Measuring range

##### Current input:

- 0/4 to 20 mA +10% overrange, 0 to 5 mA
- Short-circuit current: max. 150 mA
- Input impedance:  $\leq 5 \Omega$
- Reaction time:  $\leq 100$  ms

##### Universal input:

###### Current:

- 0/4 to 20 mA + 10% overrange, 0 to 5 mA
- Short-circuit current: max. 100 mA
- Input impedance:  $\leq 50 \Omega$

###### Voltage:

- $\pm 150$  mV,  $\pm 1$  V,  $\pm 10$  V,  $\pm 30$  V, 0 to 100 mV, 0 to 200 mV, 0 to 1 V, 0 to 10 V
- Input impedance:  $\geq 100$  k $\Omega$

###### Resistance:

30 to 3 000  $\Omega$  in 3/4-wire technology

###### Resistance thermometer:

- Pt100/500/1000, Cu50/100, Pt50 in 3/4-wire technology
- Measuring current for Pt100/500/1000 = 0.25 mA

###### Thermocouple types:

- J, K, T, N, B, S, R as per IEC584
- D, C as per ASTM E998
- U, L as per DIN43710/GOST
- Reaction time:  $\leq 100$  ms

##### Digital input:

- Voltage level -3 to 5 V low, 12 to 30 V high (as per DIN19240)
- Input voltage max. 34.5 V
- Input current typ. 3 mA with overload and reverse polarity protection
- Sampling frequency max. 10 Hz

#### 13.1.3 Galvanic isolation

Towards all other circuits



## 13.2 Output

### 13.2.1 Output signal

- Relay, transmitter power supply (standard)
- Current, voltage, pulse, intrinsically safe transmitter power supply (option)

### 13.2.2 Signal on alarm

No measured value visible on the LC display, no background illumination, no sensor power supply, no output signals, relays behave in safety-oriented manner.

### 13.2.3 Current/voltage output

Span:

0/4 to 20 mA (active), 0 to 10 V (active)

Load:

- $\leq 600 \Omega$  (current output)
- Max. loop current 22 mA (voltage output)

Signal characterization:

Signal freely scalable

Galvanic isolation towards all other circuits

### 13.2.4 Pulse output (open collector)

- Frequency range to 2 kHz
- $I_{\max} = 200 \text{ mA}$
- $U_{\max} = 28 \text{ V}$
- $U_{\text{low/max}} = 2 \text{ V}$  at 200 mA
- Pulse width = 0.04 to 2 000 ms

### 13.2.5 Relay

Signal characterization:

Binary, switches when the limit value is reached

Switch function: limit relay switches for the operating modes:

- Minimum/maximum safety
- Alternating pump control function
- Batch function
- Time control
- Window function
- Gradient
- Device malfunction
- Sensor malfunction

Switching threshold:

Freely programmable

Hysteresis:

0 to 99%

Signal source:

- Analog input signal
- Integrated value
- Digital input

Number:

4 in basic unit (can be extended to 8 relays, option)

Electrical specifications:

- Relay type: changeover
- Relay switching capacity: 250 V<sub>AC</sub> / 30 V<sub>DC</sub>, 3 A
- Switch cycles: typically 10<sup>5</sup>
- Switching frequency: max. 5 Hz
- Minimum switching load: 10 mA / 5 V<sub>DC</sub>

Galvanic isolation towards all other circuits

 Mixed assignment of low and extra-low voltage circuits is not permitted for neighboring relays.

### 13.2.6 Transmitter power supply

#### Transmitter power supply 1, terminal 81/82 (optionally intrinsically safe):

Electrical specifications:

- Output voltage: 24 V ±15%
- Output current: max. 22 mA (at U<sub>out</sub> ≥ 16 V, sustained short-circuit proof)
- Impedance: ≤ 345 Ω

Approvals:

- ATEX
- FM
- CSA

#### Transmitter power supply 2, terminal 91/92:

Electrical specifications:

- Output voltage: 24 V ±15%
- Output current: max. 250 mA (sustained short-circuit proof)

#### Transmitter power supply unit 1 and 2:

Galvanic isolation:

Towards all other circuits

#### HART®

No HART® signal influence

### 13.3 Power supply

#### 13.3.1 Terminal assignment

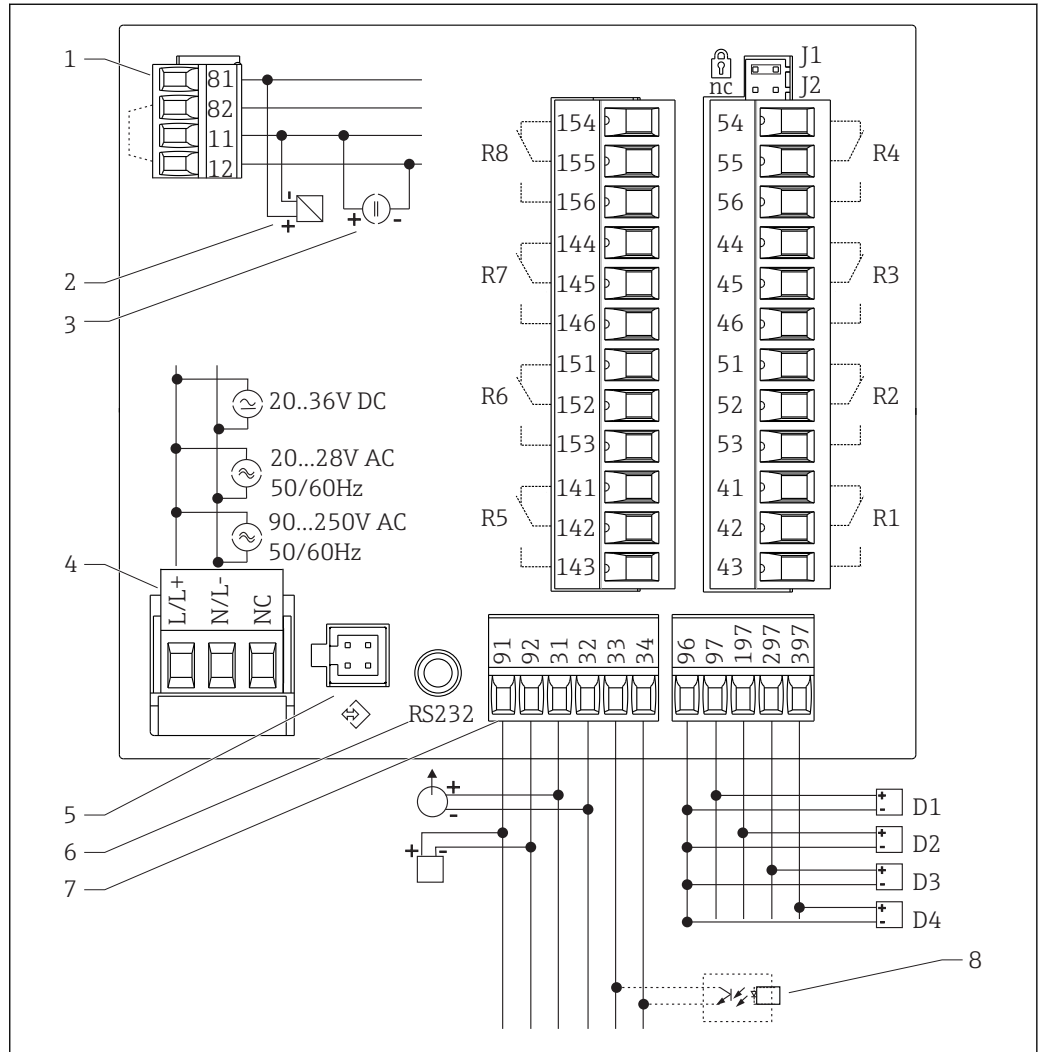

25 Terminal layout of process meter

A0028439

- |   |  |         |  |
|---|--|---------|--|
| 1 | Current input (12 and 82 internally bridged) | 7       | Transmitter power supply and analog output |
| 2 | - passive sensor                             | 8       | Open collector output                      |
| 3 | - active sensor                              | D1...D4 | Digital inputs                             |
| 4 | Voltage supply                               | R1...R4 | Relay outputs                              |
| 5 | Interface for PC operating software          | R5...R8 | Relay outputs (optional)                   |
| 6 | RS232 interface                              | J1      | Hardware write protection                  |

### Option universal input

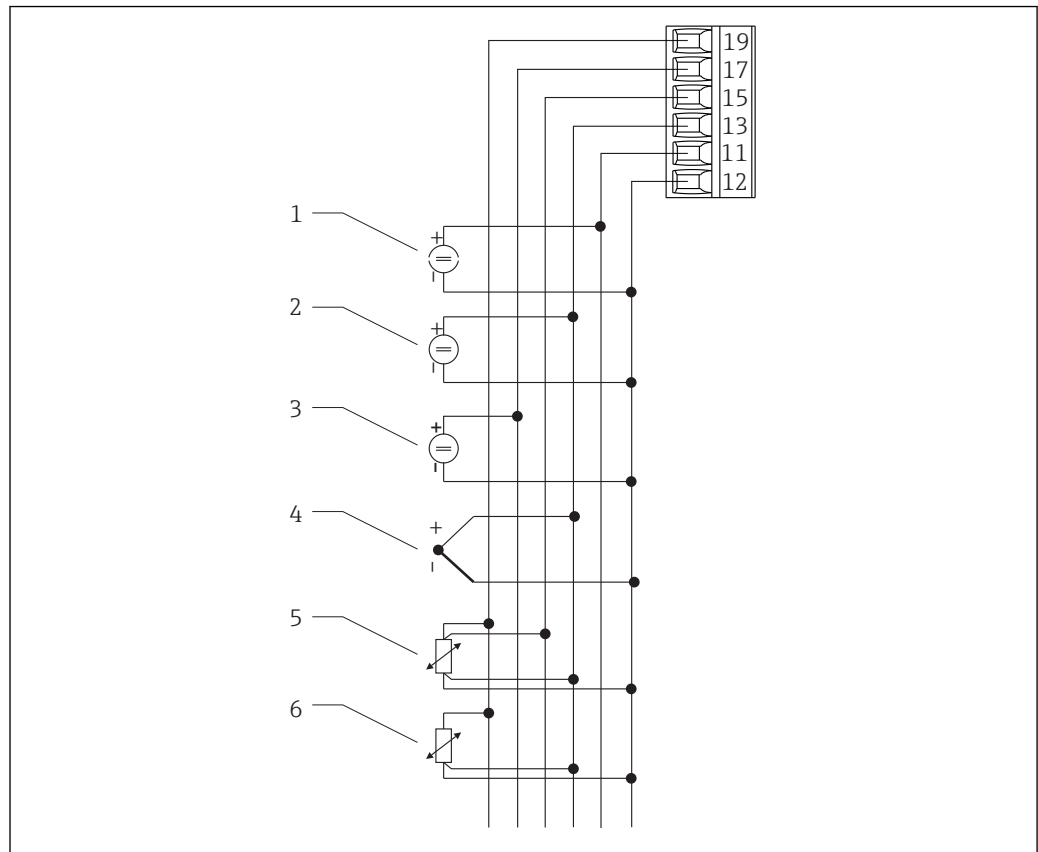

A0028457

26 Terminal layout universal input

- |   |                            |   |                                 |
|---|----------------------------|---|---------------------------------|
| 1 | Current input 0/4 to 20 mA | 4 | Thermocouples                   |
| 2 | Voltage input ±1 V         | 5 | Resistance thermometers, 4-wire |
| 3 | Voltage input ±30 V        | 6 | Resistance thermometers, wire   |

### Connection data interface

#### RS232

- Connection: jack socket 3.5 mm, rear of device
- Transmission protocol: ReadWin 2000
- Transmission rate: 38 400 Baud

### 13.3.2 Supply voltage

Power unit 90 to 250 V<sub>AC</sub> 50/60 Hz

Low voltage power unit 20 to 36 V<sub>DC</sub> bzw. 20 to 28 V<sub>AC</sub> 50/60 Hz

### 13.3.3 Power consumption

max. 24 VA

## 13.4 Performance characteristics

### 13.4.1 Reference operating conditions

Power supply: 230 V<sub>AC</sub> ±10%, 50 Hz ±0.5 Hz

Warm-up period: 90 min

Ambient temperature: 25 °C (77 °F)

### 13.4.2 Maximum measured error

#### Current input

Accuracy	0.1% of full scale
Resolution	13 bit
Temperature drift	≤ 0.4%/10 K (18 °F)

#### Universal input

	Input:	Range:	Maximum measured error of measuring range (oMR):	
Accuracy	Current	0 to 20 mA, 0 to 5 mA, 4 to 20 mA; overrange: to 22 mA	±0.10%	
	Voltage > 1 V	0 to 10 V, ±10 V, ±30 V	±0.10%	
	Voltage ≤ 1 V	±1 V, 0 to 1 V, 0 to 200 mV, 0 to 100 mV, ±150 mV	±0.10%	
	Resistance thermometer	Pt100, -200 to 600 °C (-328 to 1 112 °F) (IEC751, JIS1604, GOST) Pt500, -200 to 600 °C (-328 to 1 112 °F) (IEC751, JIS1604) Pt1000, -200 to 600 °C (-328 to 1 112 °F) (IEC751, JIS1604)		4-wire: ± (0.10% oMR + 0.3 K (0.54 °F)) 3-wire: ± (0.15% oMR + 0.8 K (1.44 °F))
		Cu100, -200 to 200 °C (-328 to 392 °F) (GOST) Cu50, -200 to 200 °C (-328 to 392 °F) (GOST) Pt50, -200 to 600 °C (-328 to 1 112 °F) (GOST)		4-wire: ± (0.20% oMR + 0.3 K (0.54 °F)) 3-wire: ± (0.20% oMR + 0.8 K (1.44 °F))
	Resistance measurement	30 to 3 000 Ω	4-wire: ± (0.20% oMR + 0.3 K (0.54 °F)) 3-wire: ± (0.20% oMR + 0.8 K (1.44 °F))	
	Thermocouples	Typ J (Fe-CuNi), -210 to 999.9 °C (-346 to 1 382 °F) (IEC584)		± (0.15% oMR + 0.5 K (0.9 °F)) from -100 °C (-148 °F)
		Typ K (NiCr-Ni), -200 to 1 372 °C (-328 to 2 502 °F) (IEC584)		± (0.15% oMR + 0.5 K (0.9 °F)) from -130 °C (-234 °F)
		Typ T (Cu-CuNi), -270 to 400 °C (-454 to 752 °F) (IEC584)		± (0.15% oMR + 0.5 K (0.9 °F)) from -200 °C (-328 °F)
		Typ N (NiCrSi-NiSi), -270 to 1 300 °C (-454 to 2 372 °F) (IEC584)		± (0.15% oMR + 0.5 K (0.9 °F)) from -100 °C (-148 °F)
		Typ B (Pt30Rh-Pt6Rh), 0 to 1 820 °C (32 to 3 308 °F) (IEC584)		± (0.15% oMR + 1.5 K (2.7 °F)) from 600 °C (1 112 °F)
		Typ D (W3Re/W25Re), 0 to 2 315 °C (32 to 4 199 °F) (ASTME998)		± (0.15% oMR + 1.5 K (2.7 °F)) from 500 °C (932 °F)
		Typ C (W5Re/W26Re), 0 to 2 315 °C (32 to 4 199 °F) (ASTME998)		± (0.15% oMR + 1.5 K (2.7 °F)) from 500 °C (932 °F)
Typ L (Fe-CuNi), -200 to 900 °C (-328 to 1 652 °F) (DIN43710, GOST)			± (0.15% oMR + 0.5 K (0.9 °F)) from -100 °C (-148 °F)	
Typ U (Cu-CuNi), -200 to 600 °C (-328 to 1 112 °F) (DIN43710)			± (0.15% oMR + 0.5 K (0.9 °F)) from -100 °C (-148 °F)	
Typ S (Pt10Rh-Pt), 0 to 1 768 °C (32 to 3 214 °F) (IEC584)			± (0.15% oMR + 3.5 K (6.3 °F)) for 0 to 100 °C (32 to 212 °F) ± (0.15% oMR + 1.5 K (2.7 °F)) for 100 to 1 768 °C (212 to 3 214 °F)	
Typ R (Pt13Rh-Pt), -50 to 1 768 °C (-58 to 3 214 °F) (IEC584)		± (0.15% oMR + 1.5 K (2.7 °F)) for 100 to 1 768 °C (212 to 3 214 °F)		

	Input:	Range:	Maximum measured error of measuring range (oMR):
Resolution		16 bit	
Temperature drift		Temperature drift: $\leq 0.1\%/10\text{ K}$ (18 °F)	

### Current output

Linearity	0.1% of full scale
Resolution	13 bit
Temperature drift	Temperature drift: $\leq 0.1\%/10\text{ K}$ (18 °F)
Output Ripple	10 mV at 500 $\Omega$ for frequencies $\leq 50\text{ kHz}$

### Voltage output

Linearity	0.1% of full scale
Resolution	13 bit
Temperature drift	Temperature drift: $\leq 0.1\%/10\text{ K}$ (18 °F)

## 13.5 Installation

### 13.5.1 Mounting location

Panel, cut-out 92 x 92 mm (3.62x3.62 in) (see 'Mechanical construction').

### 13.5.2 Orientation

Horizontal +/- 45° in every direction

## 13.6 Environment

### 13.6.1 Ambient temperature range

-20 to 60 °C (-4 to 140 °F)

### 13.6.2 Storage temperature

-30 to 70 °C (-22 to 158 °F)

### 13.6.3 Operating height

< 3 000 m (9 840 ft) above MSL

### 13.6.4 Climate class

As per IEC 60654-1, Class B2

### 13.6.5 Degree of protection

Front IP 65 / NEMA 4

Device casing IP 20

### 13.6.6 Shock and vibration resistance

2 Hz (+3/-0) ... 13.2 Hz:  $\pm 1$  mm ( $\pm 0.04$  in)

13.2 to 100 Hz: 0.7 g

### 13.6.7 Electromagnetic compatibility (EMC)

#### CE compliance

Electromagnetic compatibility in accordance with all the relevant requirements of the IEC/EN 61326 series and NAMUR Recommendation EMC (NE21). For details refer to the EU Declaration of Conformity.

Maximum measurement error  $< 1\%$  of measuring range.

Interference immunity as per IEC/EN 61326 series, industrial requirements.

Interference emission as per IEC/EN 61326 series, Class B equipment.

### 13.6.8 Electrical protection class

IEC 60529 (IP code) / NEMA 250

### 13.6.9 Condensation

Front: permitted

Device casing: not permitted

## 13.7 Mechanical construction

### 13.7.1 Design, dimensions

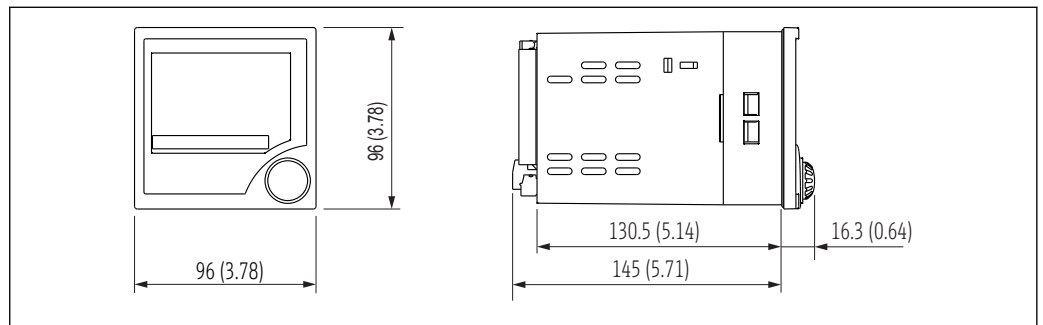

27 Dimensions of the panel meter in mm (in)

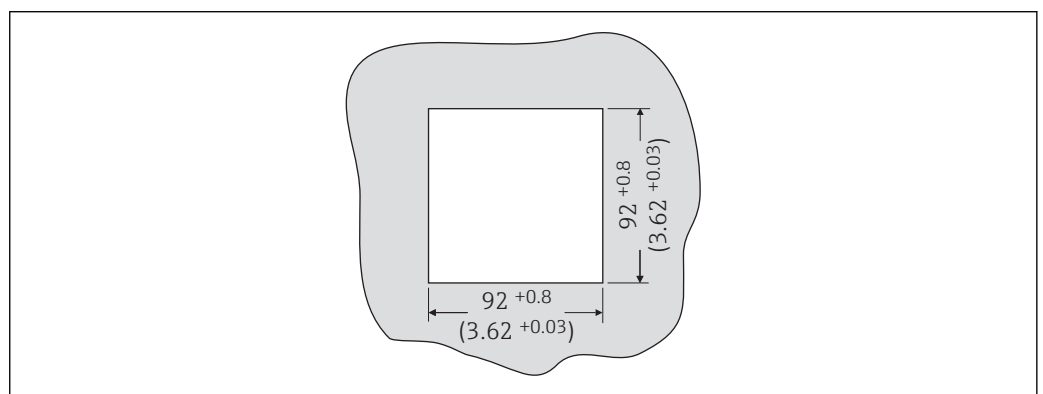

28 Panel cutout, dimensions in mm (in)

### 13.7.2 Weight

500 g (17.64 oz)

### 13.7.3 Material

- Housing front: ABS plastic, galvanized
- Housing casing: plastic PC10GF

### 13.7.4 Terminals

Pluggable screw terminals, core size 1.5 mm<sup>2</sup> (16 AWG) solid, 1 mm<sup>2</sup> (18 AWG) strand with wire ferrule

## 13.8 Operability

### 13.8.1 Local operation

#### Display elements

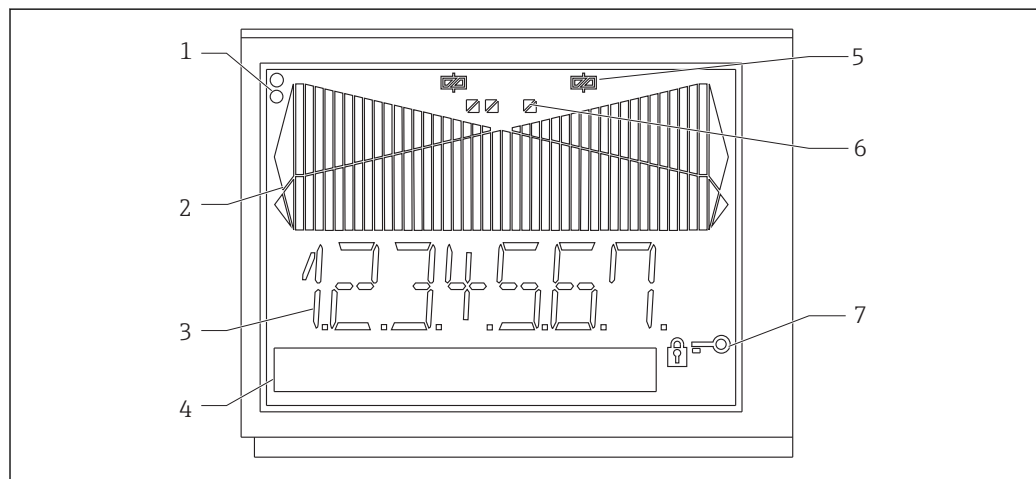

A0028477

29 Display elements of the panel meter

- 1 Device status LEDs: green - device ready for operation; red - device or sensor malfunction
- 2 Bar graph with overrange and underrange
- 3 7-digit 14-segment display
- 4 Unit and text field 9x77 dot matrix
- 5 Relay status display: if power is supplied to a relay, the symbol is displayed
- 6 Status display, digital inputs
- 7 Symbol for 'device operation locked'

- Display range
  - -99999 to +99999 for measured values
  - 0 to 9999999 for counter values
- Signaling
  - Relay activation
  - Measuring range overshoot/undershoot

#### Operating elements

Jog/shuttle dial



## 13.8.2 Remote operation

### Configuration

The device can be configured with PC software ReadWin 2000.

### Interface

CDI interface at device; connection to PC via USB box (see "Accessories")

RS232 interface at device; connection with serial interface cable (see "Accessories")

## 13.9 Certificates and approvals

### 13.9.1 CE mark

The measuring system meets the legal requirements of the applicable EC guidelines. These are listed in the corresponding EC Declaration of Conformity together with the standards applied. Endress+Hauser confirms successful testing of the device by affixing to it the CE mark.

### 13.9.2 UL approval

UL recognized component (see [www.ul.com/database](http://www.ul.com/database), search for Keyword "E225237")

### 13.9.3 EAC mark

The product meets the legal requirements of the EEU guidelines. The manufacturer confirms the successful testing of the product by affixing the EAC mark.

### 13.9.4 Ex approvals

Information about currently available Ex versions (ATEX, FM, CSA, etc.) can be supplied by your E+H Sales Center on request. All explosion protection data are given in a separate documentation which is available upon request.

### 13.9.5 Other standards and guidelines

- IEC 60529: Degrees of protection by housing (IP code)
- IEC 61010-1: Protection measures for electrical equipment for measurement, control, regulation and laboratory procedures
- CSA 1010.1 Safety requirements for electrical equipment for measurement, control, and laboratory use - General requirements
- FM 3610 Intrinsically safe apparatus and associated apparatus for use in class 1, 2 and 3, division 1 hazardous (classified) locations
- CSA C22.2.157 Intrinsically safe & non-incendive equipment for use in hazardous locations
- CSA E79-11 Electrical apparatus for explosive gas atmospheres - intrinsic safety "I"
- EN 50020 Electrical apparatus for hazardous areas - intrinsic safety "I"

## 13.10 Supplementary documentation

- System components and data manager - solutions to complete your measuring point:  
FA00016K/09
- 
- Ex-related additional documentation:  
ATEX II(1)GD: XA00053R/09/a3

## 14 Appendix

### 14.1 Flow conversion

Conversion of various units to m<sup>3</sup>/h

#### Liter

- 1 l/s = 3.6 m<sup>3</sup>/h
- 1 l/min = 0.06 m<sup>3</sup>/h
- 1 l/h = 0.001 m<sup>3</sup>/h

#### Hectoliter

- 1 hl/s = 360 m<sup>3</sup>/h
- 1 hl/min = 6 m<sup>3</sup>/h
- 1 hl/h = 0.1 m<sup>3</sup>/h

#### Cubic meter

- 1 m<sup>3</sup>/s = 3 600 m<sup>3</sup>/h
- 1 m<sup>3</sup>/min = 60 m<sup>3</sup>/h

#### Megaliter

- 1 Ml/s = 3 600 000 m<sup>3</sup>/h
- 1 Ml/min = 6 000 m<sup>3</sup>/h
- 1 Ml/h = 1 000 m<sup>3</sup>/h

#### US gallon

- 1 USgal/s = 13.6274 m<sup>3</sup>/h
- 1 USgal/min = 0.2271 m<sup>3</sup>/h
- 1 USgal/h = 0.003785 m<sup>3</sup>/h

#### US kilogallon

- 1 US kgal/s = 13 627.4444 m<sup>3</sup>/h
- 1 US kgal/min = 0.2271 m<sup>3</sup>/h
- 1 US kgal/h = 0.003785 m<sup>3</sup>/h

#### US megagallon

- 1 USMgal/s = 13 627 481.6155 m<sup>3</sup>/h
- 1 USMgal/min = 2 271 246 936 m<sup>3</sup>/h
- 1 USMgal/h = 3 785.4118 m<sup>3</sup>/h

#### US barrel

- 1 US bl/s = 429.264 m<sup>3</sup>/h
- 1 US bl/min = 7.1544 m<sup>3</sup>/h
- 1 US bl/h = 0.1192 m<sup>3</sup>/h

#### Imperial gallon

- 1 Imp.gal/s = 16.3659 m<sup>3</sup>/h
- 1 Imp.gal/min = 0.2728 m<sup>3</sup>/h
- 1 Imp.gal/h = 0.004546 m<sup>3</sup>/h

#### Imperial barrel

- 1 Imp.bl/s = 589.1955 m<sup>3</sup>/h
- 1 Imp.bl/min = 9.8195 m<sup>3</sup>/h
- 1 Imp.gal/h = 0.1637 m<sup>3</sup>/h

#### Cubic inch

- 1 in<sup>3</sup>/s = 0.05899 m<sup>3</sup>/h
- 1 in<sup>3</sup>/min = 0.00098322 m<sup>3</sup>/h
- 1 in<sup>3</sup>/h = 0.000016387 m<sup>3</sup>/h

#### Cubic foot

- 1 ft<sup>3</sup>/s = 101.9406 m<sup>3</sup>/h
- 1 ft<sup>3</sup>/min = 1.699 m<sup>3</sup>/h
- 1 ft<sup>3</sup>/h = 0.0283 m<sup>3</sup>/h

# Index

## 0 ... 9

24-hour activation function . . . . . 32

## A

Adjusting the analog input . . . . . 22

Alarm . . . . . 30

Alternating pump control . . . . . 31

Analog input . . . . . 21

Analog output . . . . . 23

## C

Calculation formula for flow measurement . . . . . 37

CE mark . . . . . 7

CE-mark . . . . . 57

## D

Declaration of Conformity . . . . . 7

Delay . . . . . 30

Device configuration . . . . . 20

Device malfunction . . . . . 44

Digital input . . . . . 24

Display . . . . . 22

## E

Error codes . . . . . 44

## F

Flow

    Calculation . . . . . 37

## I

Incorrect entries . . . . . 45

Integration . . . . . 32

Integration function . . . . . 37

## L

Limit values . . . . . 26

    Alarm operating mode . . . . . 30

    Alternate . . . . . 31

    Delay . . . . . 30

    Grad operating mode . . . . . 29

    Max operating mode . . . . . 28

    Min operating mode . . . . . 28

Linearization table . . . . . 39

    Support points . . . . . 41

## M

M1/INPUT . . . . . 21

M2/DISPLAY . . . . . 22

M3/ANALOG OUT . . . . . 23

M5/DIGITAL INP. . . . . 24

M10...17/LIMIT 1...8 . . . . . 26

M18/INTEGRATION . . . . . 32

M19/PULSE OUT . . . . . 38

M20/MIN MAX . . . . . 39

M21/LIN. TABLE . . . . . 39

M23...MXX/LINPOINTS 1...X . . . . . 41

M55/PARAMETER . . . . . 41

Menu

    ANALOG OUT . . . . . 23

    DIGITAL INP. . . . . 24

    DISPLAY . . . . . 22

    INPUT . . . . . 21

    INTEGRATION . . . . . 32

    LIMIT 1...8 . . . . . 26

    LIN. TABLE . . . . . 39

    LINPOINTS 1...X . . . . . 41

    MIN MAX . . . . . 39

    PARAMETER . . . . . 41

    PULSE OUT . . . . . 38

Min/Max memory . . . . . 39

## O

Operating parameters . . . . . 41

Operational safety . . . . . 6

## P

Preset counter . . . . . 37

Process error messages . . . . . 44

Product safety . . . . . 7

Pulse output . . . . . 38

Pump monitoring . . . . . 24

## R

Registered trademarks . . . . . 5

Requirements for personnel . . . . . 6

Return . . . . . 47

## S

Spare parts . . . . . 45

Support points . . . . . 41

## T

Tank linearization . . . . . 40

Totalizer . . . . . 37

Troubleshooting . . . . . 44

## U

UL approval . . . . . 57

[www.addresses.endress.com](http://www.addresses.endress.com)

---