



Level



Pressure



Flow



Temperature



Liquid
Analysis



Registration



Systems
Components



Services



Solutions

Explosion proof Thermocouple Assembly T55

Compact Instructions

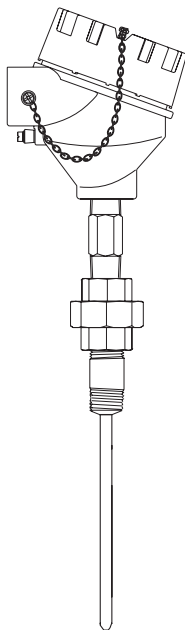

Measuring System

Explosion proof Thermocouple assembly T55 with spring loaded insert and enclosure for process industry.

The sensor is made up of a MgO insulated thermocouple as a measurement probe. The thermocouple sensor complies with the ASTM E-230 and IEC60584 specifications. The sensor is designed to ensure highest accuracy and long term stability.

Important Notice



Warning!

Electrical shock could cause death or serious injury. If the sensor is installed in a high voltage environment and a fault or installation error occurs, high voltage may be present on the connection terminals or the probe itself.

Safe and secure operation of the temperature sensor can only be guaranteed if the operating instructions of the used transmitters and all included safety notes are read, understood and followed. For Endress+Hauser temperature transmitters see enclosed CD-ROM.

Correct use

The manufacturer cannot be held responsible for damage caused by misuse of the unit. The installation conditions and connection values indicated in the operating instructions must be followed!



Warning!

The Thermocouple assembly (T55) is designed to be used in conjunction with a thermowell. It is not meant to be used directly in pressurized applications; Maximum working pressure = P_{atm} . (Atmospheric pressure)

Installation Guidelines and Safety instructions

1. Install the unit according to the relevant NEC Code and local regulations.
2. Avoid any spark due to impact, friction and installation. Anti-sparking wrenches should be utilized.
3. Approved apparatus must be installed in accordance with manufacturer's instructions, see corresponding Control Drawing:

Approval		Drawing code
XP DIP Class I, II, III Div. 1+2	CSA	ZD052R/09/en
XP NI DIP Class I, II, III Div. 1+2	CSA	ZD054R/09/en
XP DIP Class I, II, III Div. 1+2	FM	ZD056R/09/en
XP NI DIP Class I, II, III Div. 1+2	FM	ZD063R/09/en

The accessories for pipe connections and the appropriate gaskets and sealing rings are not supplied with the sensors. These are the customer's responsibility. For further information regarding connections, please refer to the corresponding Standards.

Installation and operation

The unit is constructed using the most up to date production equipment and complies with the safety requirements of the local guidelines. However, if it is installed incorrectly or misused, certain application dangers can occur. Installation, wiring and maintenance of the unit must only be completed by trained, skilled personnel who are authorized to do so by the plant operator. The plant operator must make sure that the measurement system has been correctly wired to the connection schematics. Procedures indicated in these instructions must be followed.

Returns

Please follow the Return Authorization Policy which is attached with this manual.

Safety pictograms and symbols

 Note!

Notes draw attention to activities or procedures that can have a direct influence on operation or trigger an unforeseen device reaction if they are not carried out properly.

 Caution!

Cautions draw attention to activities or procedures that can lead to persons being injured or to incorrect device operation if they are not carried out properly.

 Warning!

Warnings draw attention to activities or procedures that can lead to persons being seriously injured, to safety risks or to the destruction of the device if they are not carried out properly.

Though the information provided herein is believed to be accurate, be advised that the information contained herein is NOT a guarantee of satisfactory results. Specifically, this information is neither a warranty nor guarantee, expressed or implied, regarding performance; merchantability, fitness, or other matter with respect to the products; and recommendation for the use of the product/process information in conflict with any patent. Please note that Endress+Hauser reserves the right to change and/or improve the product design and specifications without notice.

Installation

Installation locations

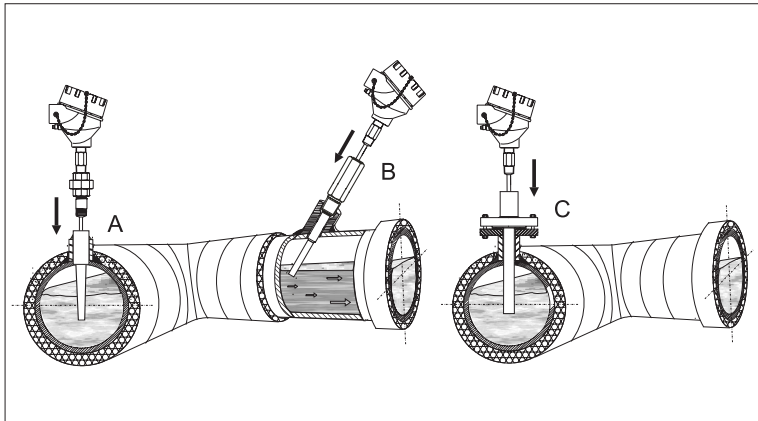

Examples of spring loaded insert installation.

- A: Explosion proof Thermocouple assembly T55 installed within a socket weld thermowell
- B: Explosion proof Thermocouple assembly T55 installed within a tilted installed threaded thermowell
- C: Explosion proof Thermocouple assembly T55 installed within a flanged thermowell

For installation proceed as follows:

1. Seal the extension nipples with TFE tape before screwing in the device.
2. Screw the explosion proof Thermocouple assembly T55 only into an already prepared thermowell.

⚠ Warning!

Do not install the Explosion proof Thermocouple assembly T55 directly to the process pipe or process container wall. Otherwise it could cause death or serious injury!

Electrical connection-wiring diagrams

Head mounted transmitter

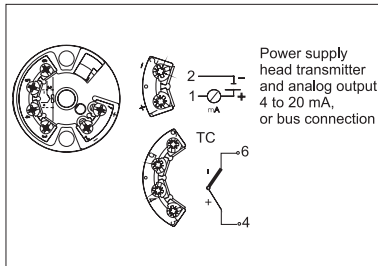

Field mounted transmitter

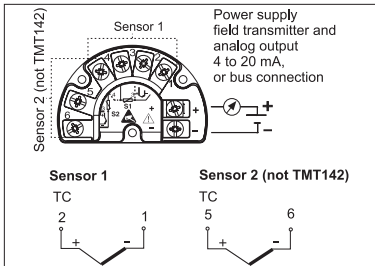

Terminal block mounted

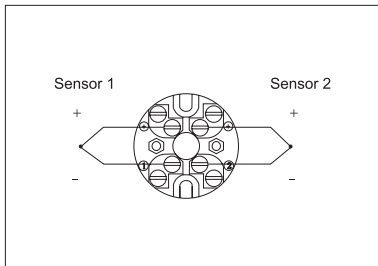

Wire specifications Thermocouple grade, TFE insulated 20AWG, 7 strands with stripped ends

Flying leads, standard 3" for wiring in connection head, head transmitter mounted or terminal block mounted

Flying leads, 5½" for wiring with TMT162 or TMT142 assembly

 Note!

The blocks and transmitters are shown as they will sit inside the heads in reference to the conduit opening. ALWAYS terminate leads to the outside screw!

Dimensions

for T55 assembly with spring loaded insert and flamepath nipple (dimensions in inches).

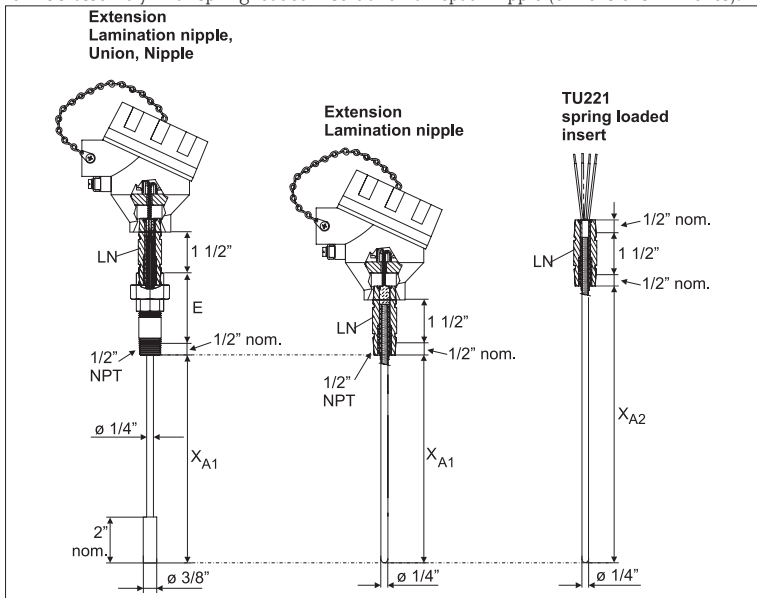

E = Extension length (nom. dimension, see table)

LN = Lamination nipple (flamepath nipple)

X_{A1} = Insert immersion length (see table)

X_{A2} = Spring loaded insert immersion length TU221 as spare part with lamination nipple

 Note: For spare part spring loaded insert, TU221, please contact Endress+Hauser!

X_{A1}	E (nom. dimension)
4", 6", 9", 12", 14" specified length 4" to 100" in $\frac{1}{2}$ " increments	Lamination Nipple Union Nipple (LUN)
X_{A2}	3" or 6"
Calculate as follows: $X_{A2} = X_{A1} + E$	

Recommended minimum immersion

2.5 inches for the ¼" OD thermocouple sheath, nominal

Technical data

Upper temperature limits for various thermocouple types in °F (°C)					
Sheath OD	Type T	Type J	Type E	Type K	Type N
Ø ¼"	700 °F (370 °C)	1330 °F (720 °C)	1510 °F (820 °C)	2100 °F (1150 °C)	

Thermocouple color codes as per ASTM E-230

Weight

From 1 to 5.5 lbs

Material	Max. temp. rating	Application notes
316SS	1700 °F (927 °C)	Superior corrosion resistance. Duplex version of type N is not available with 316SS sheaths.
Inconel 600	2100 °F (1149 °C) ¹	Excellent oxidation and corrosion resistance at high temperature. Not to be used in sulphurous atmospheres over 1000 °F (538 °C). Types T & J are not available with Inconel 600 sheaths.

1) Max. working temperature under oxidizing conditions; reducing conditions reduce max. temp. to 1900°F (1038°C).

Shock and vibration resistance 4g/2 to 150 Hz as per IEC 60 068-2-6

Ambient temperature limits

Housing without head-mounted transmitter	
Aluminium pressure die-cast housing	-58 to 212 °F (-50 to 100 °C)
Stainless steel housing	-58 to 212 °F (-50 to 100 °C)
Housing with head-mounted transmitter	
All types of housing	-40 to 185 °F (-40 to 85 °C)
Field transmitter	
with display	-40 to 158 °F (-40 to 70 °C)
without display	-40 to 185 °F (-40 to 85 °C)

Performance Characteristics

Maximum measured error

Type	Temperature range		Standard Tolerance in % and °C* (whichever is greater)	
	°C	°F	IEC class 1	IEC class 2
E	0 to 870	32 to 1600	± 1 or ± 0.4%	± 1.7 or ± 0.5%
J	0 to 760	32 to 1400	± 1.1 or ± 0.4%	± 2.2 or ± 0.75%
K	0 to 1260	32 to 2300	± 1.1 or ± 0.4%	± 2.2 or ± 0.75%
T	0 to 370	32 to 700	± 0.5 or ± 0.4%	± 1 or ± 0.75%
N	0 to 1260	32 to 2300	± 1.1 or ± 0.4%	± 2.2 or ± 0.4%

* For measurement errors in °F, calculate using equation above in °C, then multiply the outcome by 1.8.

Dielectrical strength

The units are factory tested with 850 V_{DC} for one second between live parts (leads/terminals) and exposed non-current-carrying metal parts (e.g. insert sheath)

Supplementary documentation

All important Temperature Operating Instructions, particularly with regard to head and field transmitters are available on CD-ROM, find enclosed or order by order number:

SONDTT-AG.

USA	Canada	México	Instruments International
Endress+Hauser, Inc. 2350 Endress Place Greenwood, IN 46143 USA Tel. 317-535-7138 Fax 317-535-8498 Sales 888-ENDRESS Service 800-642-8737 inquiry@us.endress.com www.us.endress.com	Endress+Hauser Canada 1075 Sutton Drive Burlington, ON L7L 5Z8 Canada Tel. 905-681-9292 800-668-3199 Fax 905-681-9444 www.ca.endress.com	Endress+Hauser México S.A. de C.V. Fernando Montes de Oca 21 Edificio A Piso 3 Fracc. Industrial San Nicolás 54030 Tlalnepanitla de Baz Estado de México México Tel. +52 55 5321 2080 Fax +52 55 5321 2099 mailto: www.mx.endress.com	Endress+Hauser Instruments International AG Kaegenstrasse 2 4153 Reinach Switzerland Tel. +41 61 715 81 00 Fax +41 61 715 25 00 www.endress.com info@ii.endress.com