

Technical Information

CYR52

Ultrasonic cleaning



Application

The CYR52 ultrasonic cleaning unit is used to clean turbidity sensors that are installed in pipes.

Your benefits

- The sensor remains always clean.
- No process interruption for sensor cleaning
- No contamination of the medium caused by sensor cleaning

Function and system design

Measuring arrangement

The complete ultrasonic cleaning system comprises:

- Ultrasonic generator
- Ultrasonic transducer
- Assembly or pipe with turbidity sensor
- Liquiline CM44x transmitter

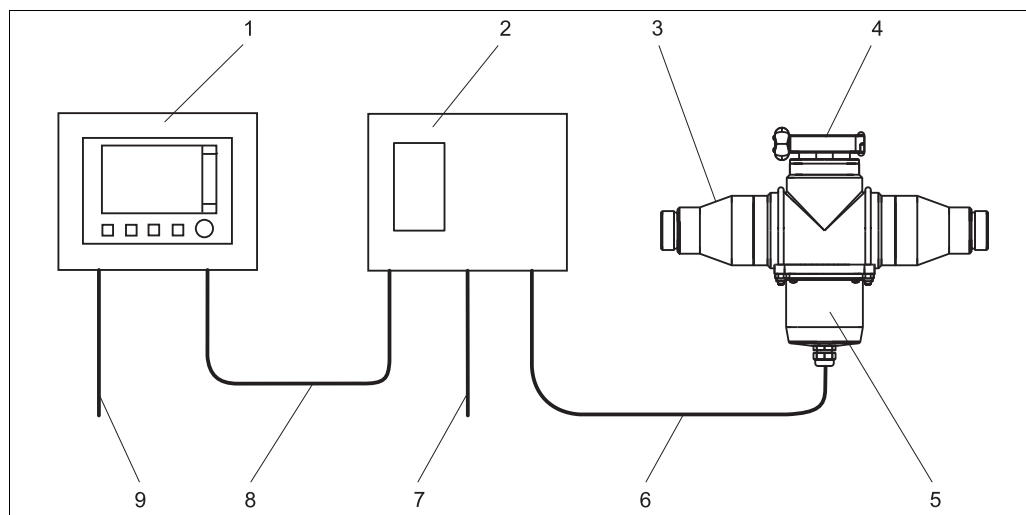

Ultrasonic cleaning with Flowfit CUA252 assembly

- | | | | |
|---|---------------------------------------|---|--|
| 1 | Liquiline CM44x transmitter | 6 | Power supply cable for ultrasonic transducer |
| 2 | Ultrasonic generator | 7 | Mains voltage cable for ultrasonic generator |
| 3 | Flowfit CUA252 flow assembly | 8 | Control cable |
| 4 | Clamp connection for turbidity sensor | 9 | Mains voltage cable for transmitter |
| 5 | Ultrasonic transducer | | |

Function

The cleaning effect is achieved by generating cavitation in liquid medium. Thus adhesive soiling on the sensor is dissolved and removed by the flow.

The ultrasonic transducer is mounted face to face with the turbidity sensor directly on the assembly or on the pipe.

Output

Operating frequency of the ultrasonic cleaning

approx.. 40 kHz

Power supply

Connection

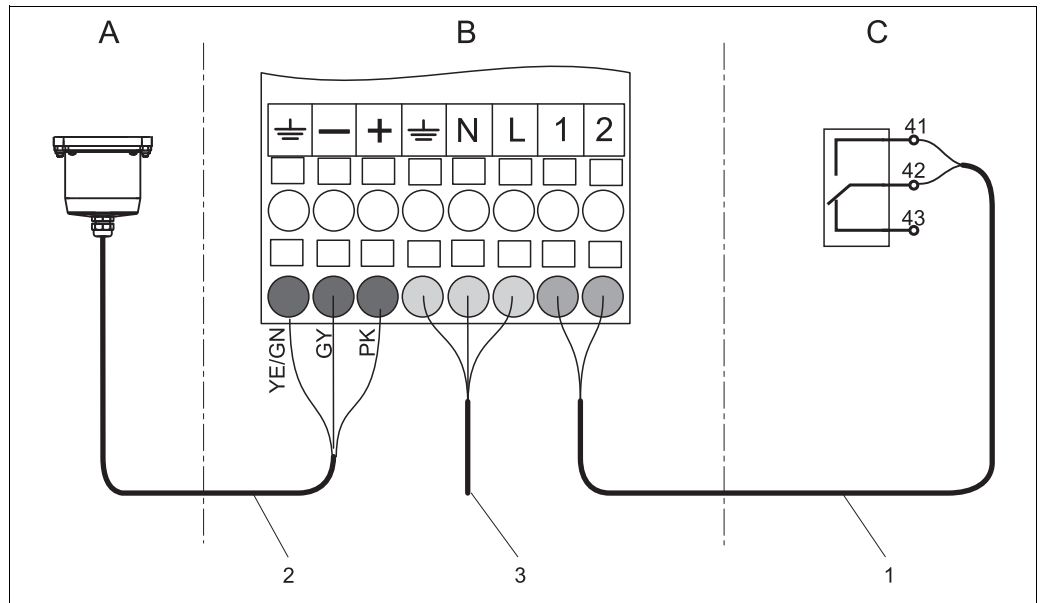

Wiring diagram

- A Ultrasonic transducer
 B Terminal block in ultrasonic generator
 C Relay in transmitter
 1 Control cable
 2 Power supply cable
 3 Mains connection

Supply voltage

Depends on the order version:
 230 VAC / 50 Hz
 115 VAC / 60 Hz

NOTICE

The device does not have a mains switch

- ▶ The customer must provide a protected circuit breaker in the vicinity of the device.
- ▶ The circuit breaker must be a switch or a power-circuit breaker, and you must label it as the circuit breaker for the device.

Power consumption

max. 50 VA

Installation

Installation conditions

The ultrasonic transducer is mounted face to face with the turbidity sensor.

Installation options

With Flowfit CUA252 flow assembly

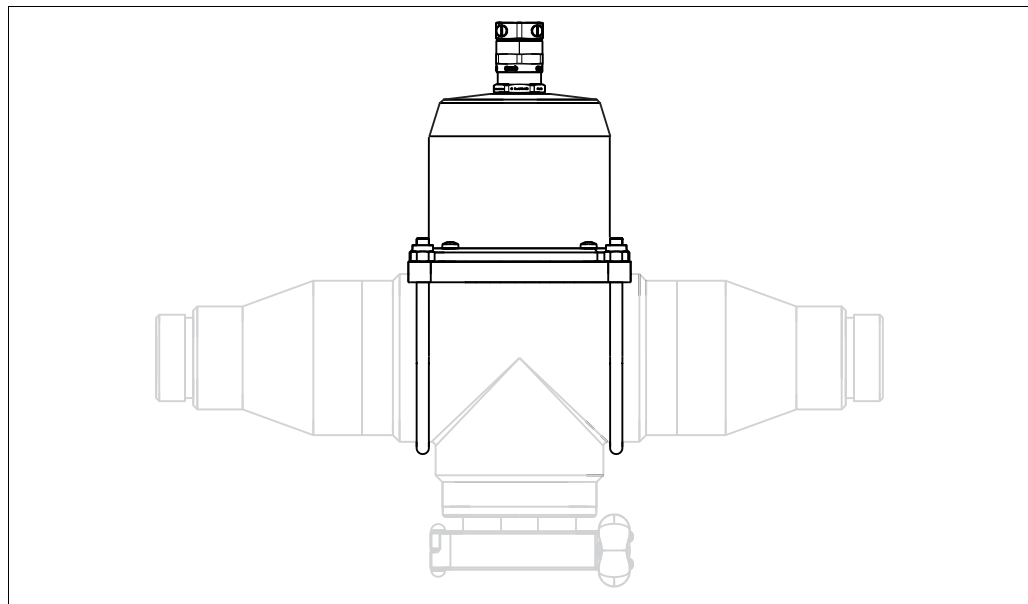

a0022751

Ultrasonic transducer on Flowfit CUA252 assembly

With Flowfit CUA262 flow assembly

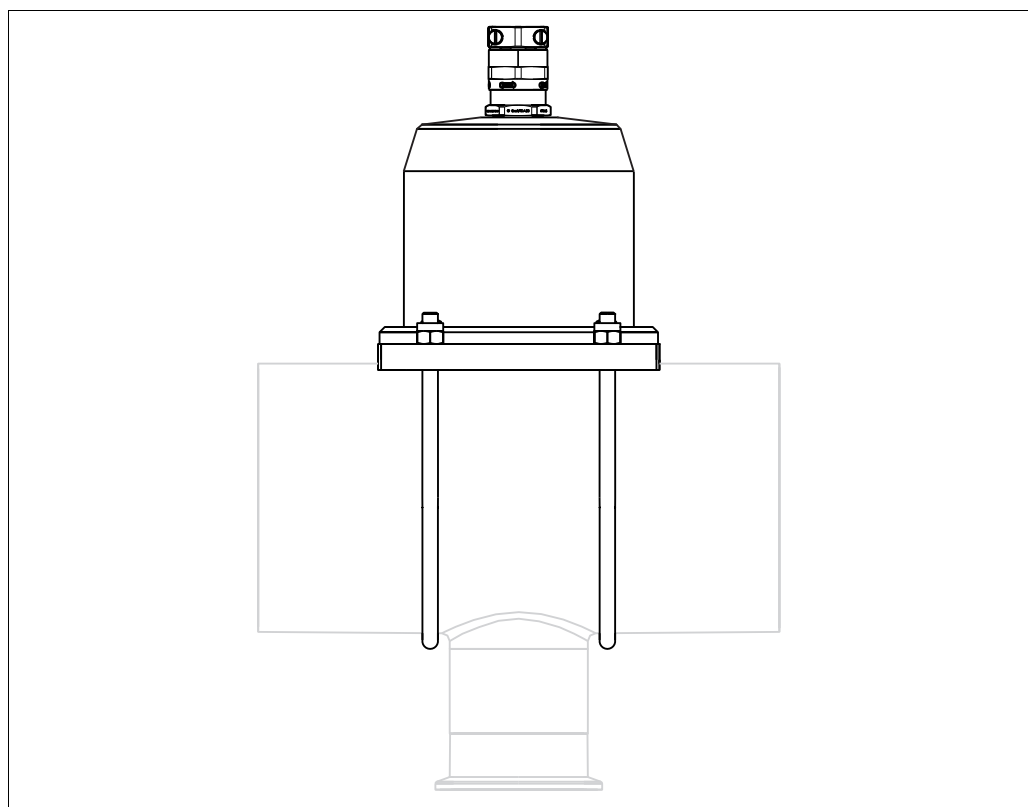

a0022752

Ultrasonic transducer on Flowfit CUA262 assembly

With assembly CUS31

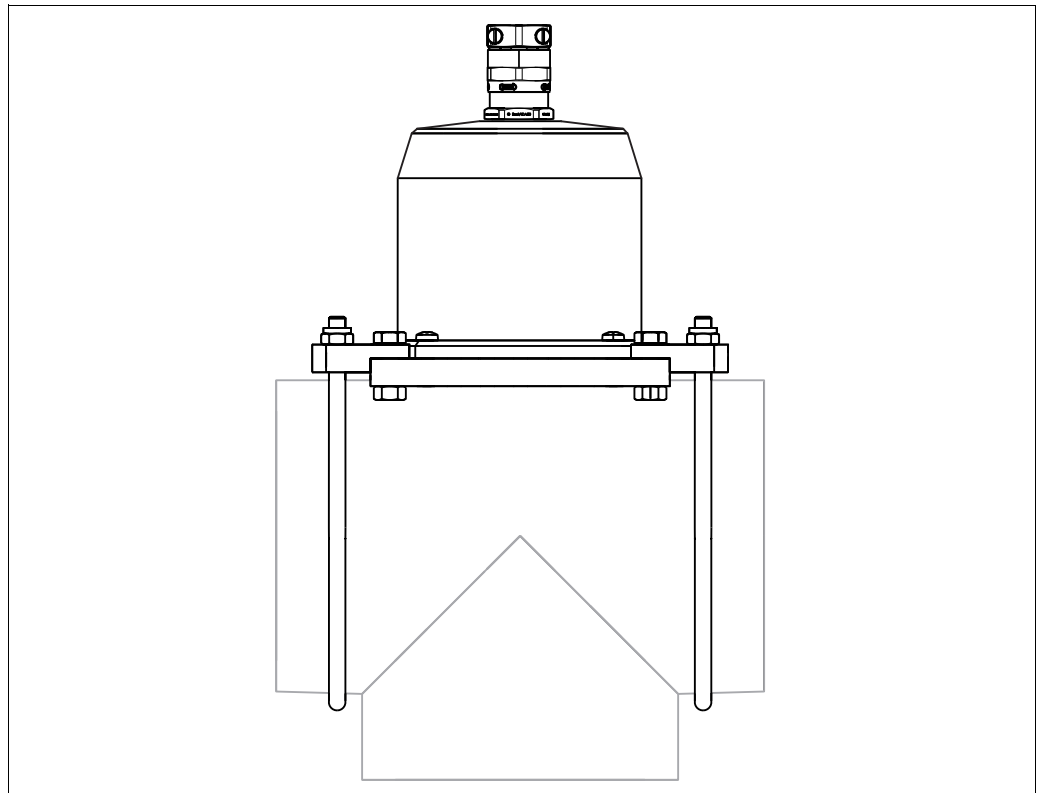

Ultrasonic transducer with assembly of CUS31

a0022754

Mounted on a pipe

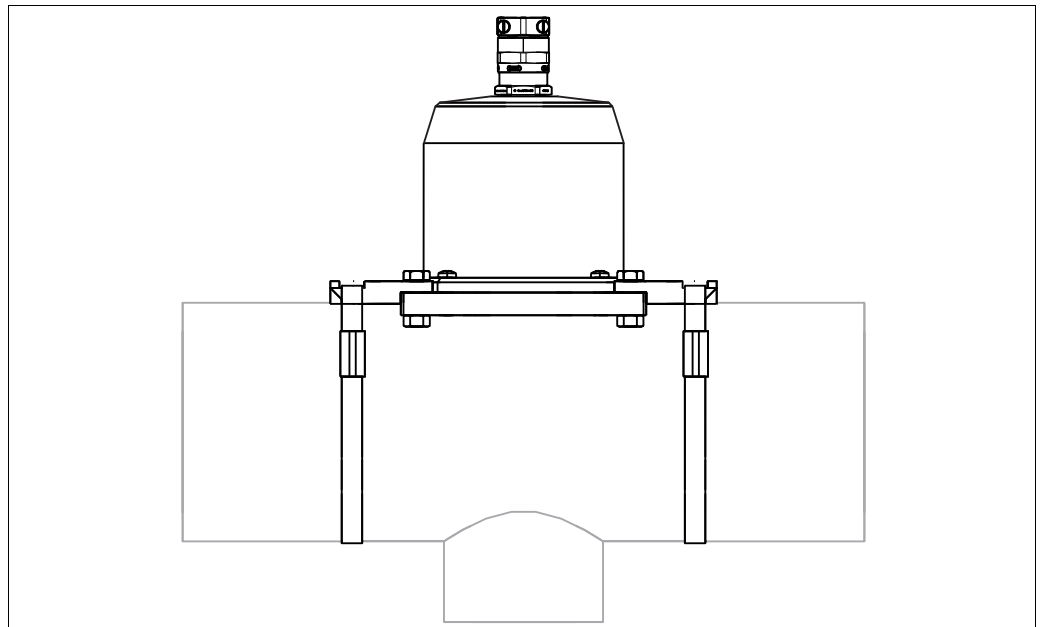

Ultrasonic transducer mounted on a pipe

a0022757

Environment

Ambient temperature range	Ultrasonic transducer:	0 to 60 °C (32 to 140 °F), non-freezing, non-condensing
	Ultrasonic generator:	-10 to +60 °C (+14 to 140 °F), non-condensing
Storage temperature	0 to 60 °C (32 to 140 °F)	
Electromagnetic compatibility	Interference emission and interference immunity as per EN 61326-1:2006, EN 61326-2-3:2006	
Degree of protection	Ultrasonic transducer:	IP 68
	Ultrasonic generator:	IP 66/67
Humidity	10 to 95 %, non-condensing	

Mechanical construction

Dimensions ultrasonic transducer

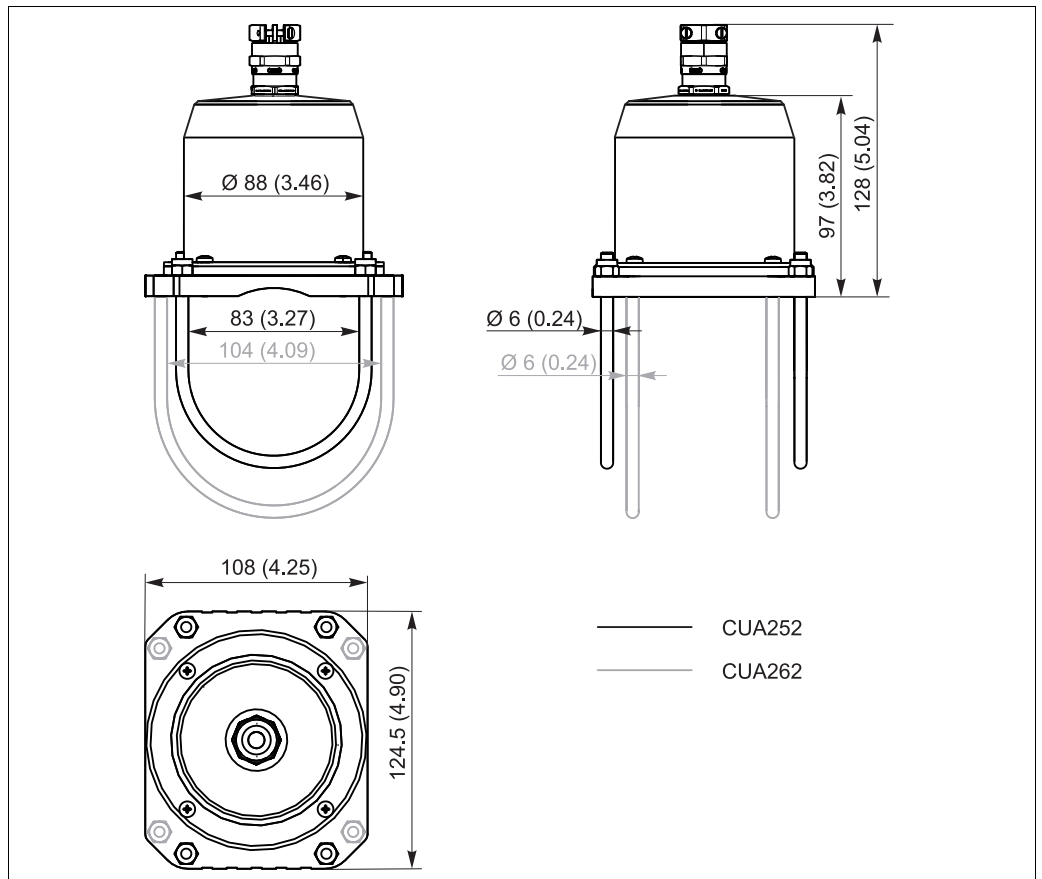

Dimensions in mm (inch) for CUA252 and CUA262

a0022750

- i** In the case of the ultrasonic transducer factor in a clearance of approx. 100 mm (4 inch) above the cable gland for the power supply cable.

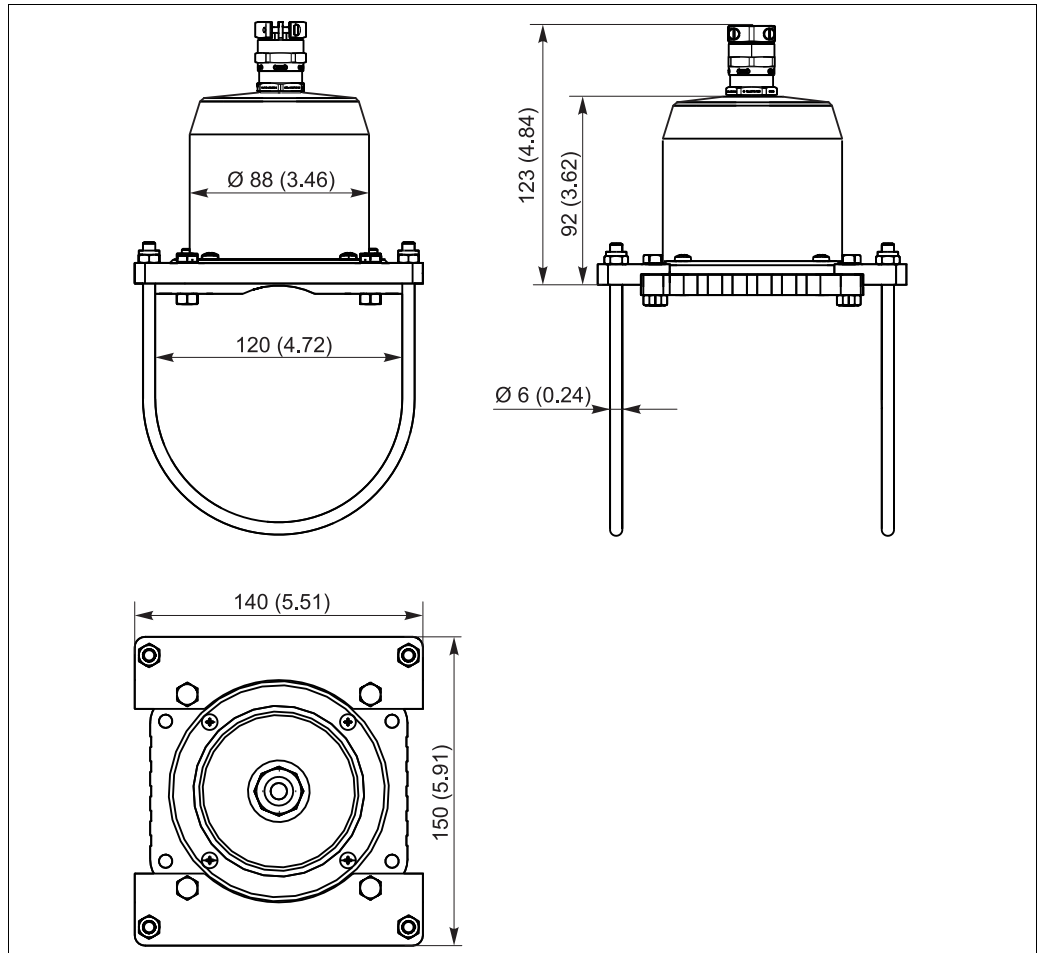

a0022755

Dimensions in mm (inch) for assembly of CUS31

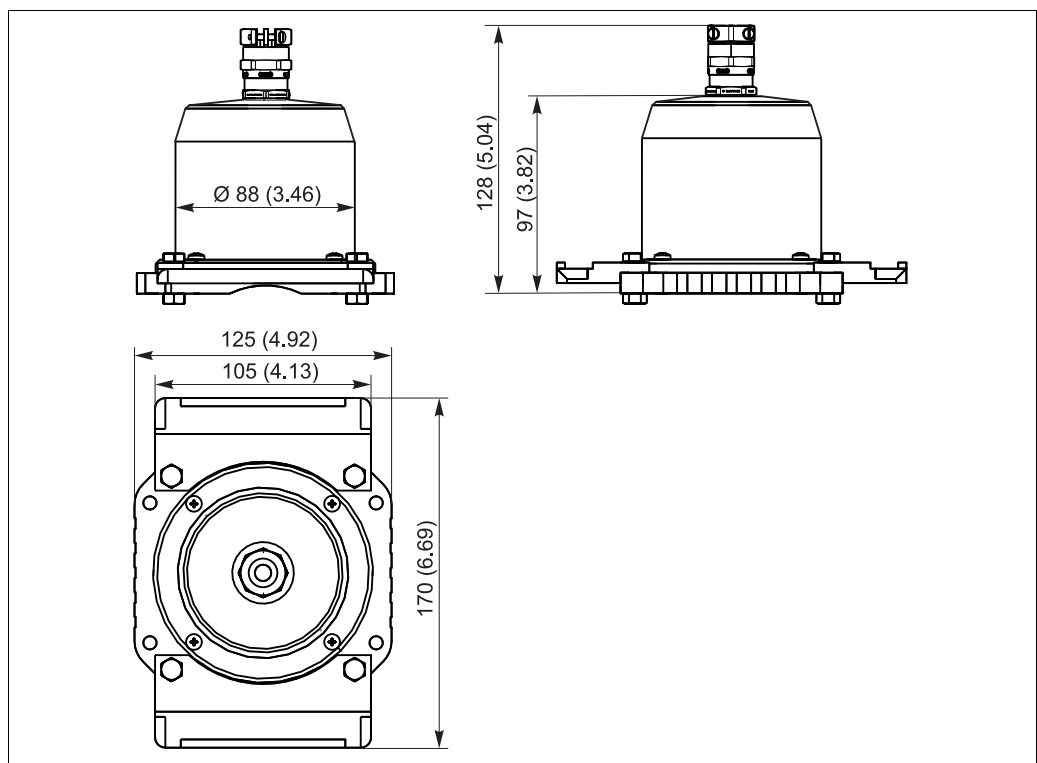

a0022756

Dimensions in mm (inch) for pipe mounting

Dimensions ultrasonic generator

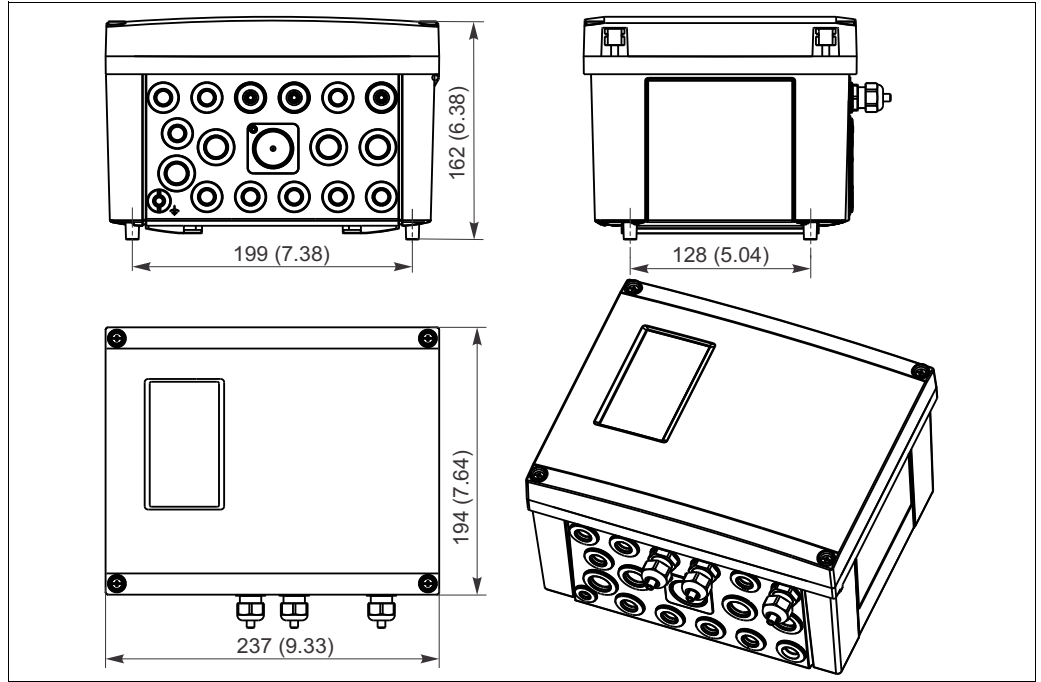

Dimensions in mm (inch)

Weight

Ultrasonic transducer:	0.72 kg (1.59 lbs), with 3 m cable
Ultrasonic generator:	2.2 kg (4.85 lbs)

Materials

Ultrasonic transducer

Cover:	PE
Floor:	Aluminum
Cable:	TPE-U mix; 3xLi9Y 0.75; sheath: Ø 6.6 mm Minimum bending radius: 66 mm (2.6 inch) when cable can move freely 33 mm (1.3 inch) when cable cannot move freely

Ultrasonic generator

Housing:	PC-FR
Housing seal:	EPDM
Cable glands:	Polyamide

Ordering information

Product page

You can create a valid and complete order code online using the Configurator tool:

Enter the following addresses in your browser to access the product page:

www.endress.com/cyr52

Product configurator

On the right-hand side of the product page, you will find the navigation area:

1. Under "Device Support", click "Configure your selected product".
 - ↳ The Configurator opens in a new window.
 2. Configure the device according to your requirements by selecting all options.
 - ↳ This ensures that you will receive a valid and complete order code.
 3. Export the order code as a PDF or Excel file. To do so, click on the relevant button at the top of the selection window.
-

Scope of delivery

The scope of delivery of the ultrasonic cleaning system comprises:

- 1 Ultrasonic generator
- 1 Ultrasonic transducer
- Mounting material depending on the order version
- 1 Set of Operating Instructions BA01300C/07/EN

Accessories

- i** The most important accessories available at the time this document went to print are listed below. Contact your Service Department or sales center for accessories that are not listed here.

Installation accessories

Description	Order number
Mounting paste for CYR52	71242140
Mounting kit for CUA252	71242141
Mounting kit for CUA262	71242142
Mounting kit for flow assembly CUS31 E/S	71242143
Mounting kit, variable	71242145
Post mounting kit for securing the ultrasonic generator to horizontal and vertical posts and pipes	71096920

The CYY101 weather protection cover for field devices is absolutely essential

- Material: stainless steel 1.4301 (AISI 304)
- Order No. CYY101-A

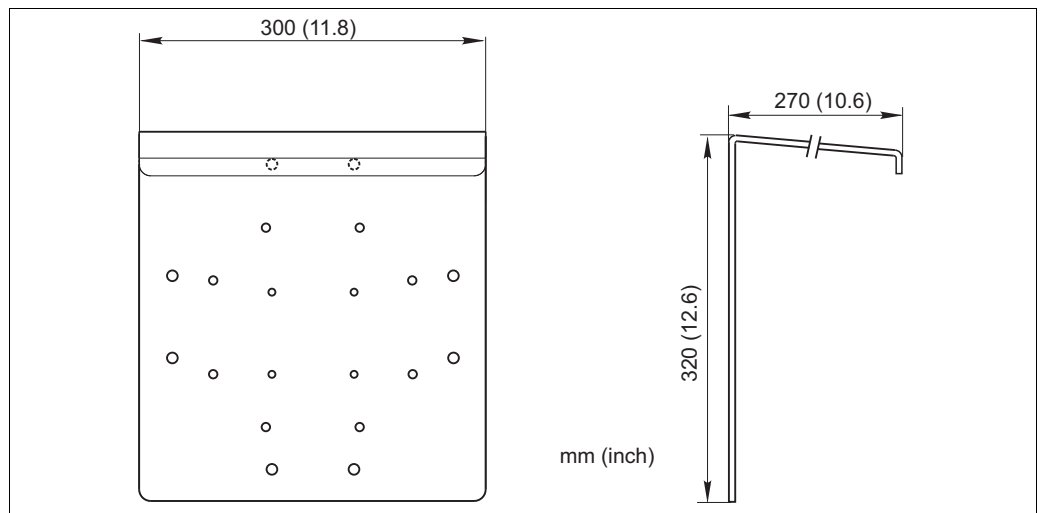

Weather protection cover for field devices

a0019166

www.addresses.endress.com
