

# Technical Information

## Omnigrad TA540, TA541

Industrial protection tube



Heavy duty - General purpose protection tube,  
threaded or flanged weld type

### Application

The thermowell is designed for use with resistance and thermocouple thermometers mainly in heavy duty applications.

### Your benefits

- TA540 and TA541 are industry standard protection tubes manufactured from pipe.
- The process connection can either be threaded or flanged weld.
- The stem shape can be straight or stepped for fast response time.
- Extension, immersion length and total length can be chosen according to process requirements.
- A wide choice of standard pipe sizes, materials and process connections is available.
- Special versions can be manufactured according to specifications.
- The connection to the thermometer of the TA540 is a female thread, and in the case of TA541 a male thread.

## Technical data

	TA540	TA541			
Standard reference	ENI TUB 1, ENI TUB 2, ENI TUB 3, ENI TUB 4	-			
Extension	Cylindrical extension: Ø35 mm (1.38 in)	Cylindrical extension: in pipe size			
Protection tube diameter / wall thickness	¼"	sch. 40 (13.7 x 9.23 mm)	-		
		sch. 80 (13.7 x 7.65 mm)			
	½"	sch. 40 (21.34 x 15.80 mm)		½"	sch. 40 (21.34 x 15.80 mm)
		sch. 80 (21.34 x 13.87 mm)			sch. 80 (21.34 x 13.87 mm)
	¾"	sch. 40 (26.67 x 20.93 mm)		¾"	sch. 40 (26.67 x 20.93 mm)
		sch. 80 (26.67 x 18.85 mm)			sch. 80 (26.67 x 18.85 mm)
Standard insert diameter	6 mm (¼ in)				

### Process

#### Process temperature range

For the maximum operating temperatures, see the 'Material' section.

#### Process pressure (static)

Process connection	Standard	Max. process pressure
Flange	EN1092-1	Depending on the flange pressure rating PN: 40 bar, 63 bar, 100 bar or 160 bar.
	ASME B16.5	Depending on the flange pressure rating: 150 psi, 300 psi, 400 psi, 600 psi, 900 psi, 1500 psi, 2500 psi

#### Permitted flow velocity depending on the immersion length

The maximum flow velocity tolerated by the thermowell diminishes with increasing thermowell immersion length exposed to the stream of the fluid. In addition, it depends on the shape and size of the thermowell, the medium type, process temperature and process pressure.



#### Thermowell sizing tool

It is possible to check the mechanical loading capacity as a function of the installation and process conditions online in the TW Sizing Module for thermowells in the Endress+Hauser Applicator software. See <https://wapps.endress.com/applicator>

### Connection to thermometer

Protection tube	Thread
TA540	½" NPT, ¾" NPT, M20x1,5 - female
TA541	½" NPT, ¾" NPT, G½", G¾" - male

### Process connection

#### TA540

Thread or flange					
Thread	½" NPT as per ASME B 1.20.1	¾" NPT as per ASME B 1.20.1	1" NPT as per ASME B 1.20.1	1½" NPT as per ASME B 1.20.1	M20x1,5 as per ISO 724
Engagement length	8 mm (0.31 in)	8.5 mm (0.33 in)	10 mm (0.4 in)	10.5 mm (0.41 in)	15 mm (0.6 in)
Flange type	Blind flange according to EN1092-1 or ASME B16.5				
Flange welding	Double sided standard weld				

TA541

Thread or flange			
Thread	¾" NPT as per ASME B 1.20.1	1" NPT as per ASME B 1.20.1	1½" NPT as per ASME B 1.20.1
Flange type	Blind flange according to EN1092-1 or ASME B16.5		
Flange welding	Double sided standard weld		

Tip

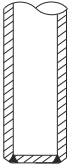
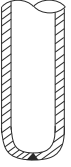
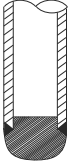
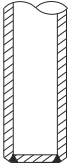
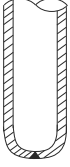
Protection tube	Bottom thickness					Bottom shape
		¼"	½"	¾"		
TA540	sch. 40	¼"	½"	¾"	 A0023432	straight
		3 mm	3 mm	3 mm		
	sch. 80	3.5 mm	4 mm	4 mm		
	 A0023433			 A0023434		round
Bottom thickness = wall thickness			Bottom thickness > wall thickness			
TA541	sch. 40	½"	¾"	 A0023432	straight	
		3 mm	3 mm			
	sch. 80	4 mm	4 mm			
	Bottom thickness = wall thickness			 A0023433		round

**Material**

Protection tube, process connection

The temperatures for continuous operation specified in the following table are only intended as reference values for use of the various materials in air and without any significant compressive load. The maximum operation temperatures are reduced considerably in some cases where abnormal conditions such as high mechanical load occur or in aggressive media.

Material name	Short form	Recommended max. temp. for continuous use in air	Properties
AISI 316/1.4401	X5CrNiMo 17-12-2	650 °C (1 202 °F)	<ul style="list-style-type: none"> <li>▪ Austenitic, stainless steel</li> <li>▪ High corrosion resistance in general</li> <li>▪ Particularly high corrosion resistance in chlorine-based and acidic, non-oxidizing atmospheres through the addition of molybdenum (e.g. phosphoric and sulfuric acids, acetic and tartaric acids with a low concentration)</li> </ul>
AISI 316L/ 1.4404 1.4435	X2CrNiMo17-12-2 X2CrNiMo18-14-3	650 °C (1 202 °F)	<ul style="list-style-type: none"> <li>▪ Austenitic, stainless steel</li> <li>▪ High corrosion resistance in general</li> <li>▪ Particularly high corrosion resistance in chlorine-based and acidic, non-oxidizing atmospheres through the addition of molybdenum (e.g. phosphoric and sulfuric acids, acetic and tartaric acids with a low concentration)</li> <li>▪ Increased resistance to intergranular corrosion and pitting</li> <li>▪ Compared to 1.4404, 1.4435 has even higher corrosion resistance and a lower delta ferrite content</li> </ul>
AISI A105/ 1.0460	C22.8	450 °C (842 °F)	<ul style="list-style-type: none"> <li>▪ Heat-resistant steel</li> <li>▪ Resistant in nitrogen-containing atmospheres and atmospheres that are low in oxygen; not suitable for acids or other aggressive media</li> <li>▪ Often used in steam generators, water and steam pipes, pressure vessels</li> </ul>
AISI 446 / ~1.4762/ ~1.4749	X10CrAl24 / X18CrNi24	1 100 °C (2 012 °F)	<ul style="list-style-type: none"> <li>▪ A ferritic, heat resistant, high-chromium stainless steel</li> <li>▪ Very high resistance to reducing sulphurous gases and salts with low content of oxygen</li> <li>▪ Very good resistance to constant as well as cyclical thermal stress, to incineration ash corrosion and to melts of copper, lead and tin</li> <li>▪ Poorly resistant to gases containing nitrogen</li> </ul>

## Mechanical construction

### Protection tube TA540

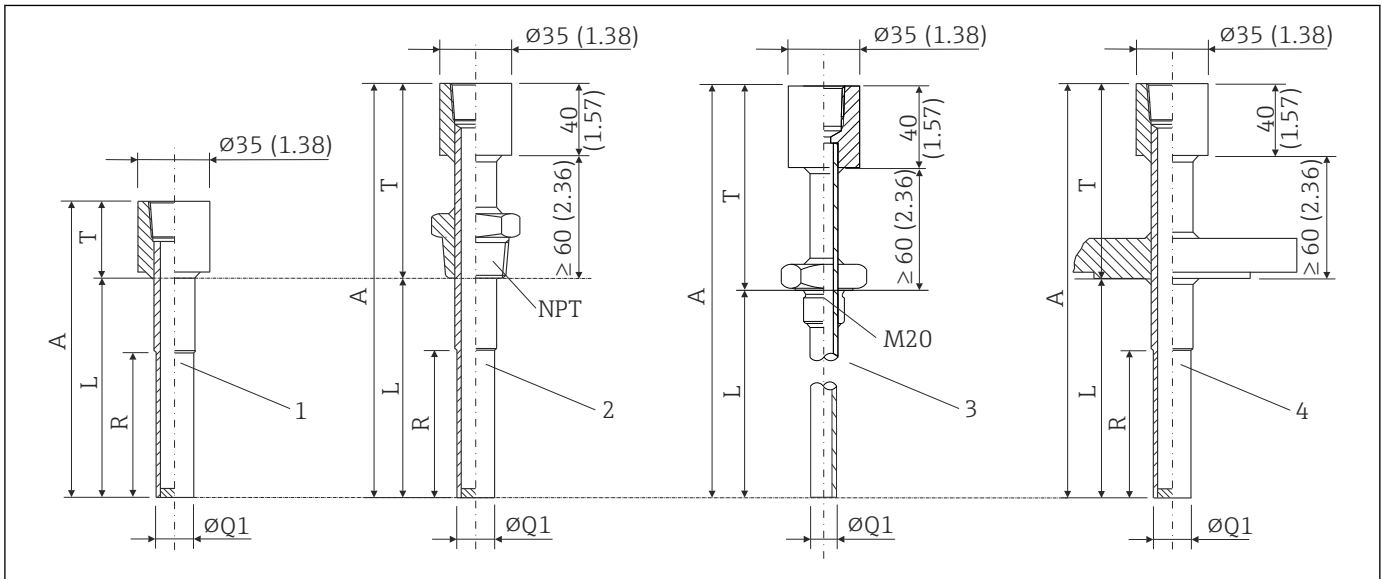

A0016111

1 Protection tube dimensions of the TA540 in mm (in)

- 1 Protection tube without process connection
- 2 Protection tube with NPT thread as process connection
- 3 Protection tube with M20 thread as process connection
- 4 Protection tube with flange as process connection

Pos. no.	Description
A	Total length (A=T+L)
L	Immersion length
ØQ1	Diameter protection tube tip
R	Length of protection tube tip
T	Extension

#### Gasket

For cylindrical threads (M20x1.5) a gasket must be used to seal the connection.

Possible gasket dimensions:

M20x1.5: gasket 24x20.3x1.5 copper

The material of the gasket has to be resistant against the process medium. The gasket is not part of the delivery.

Protection tube TA541

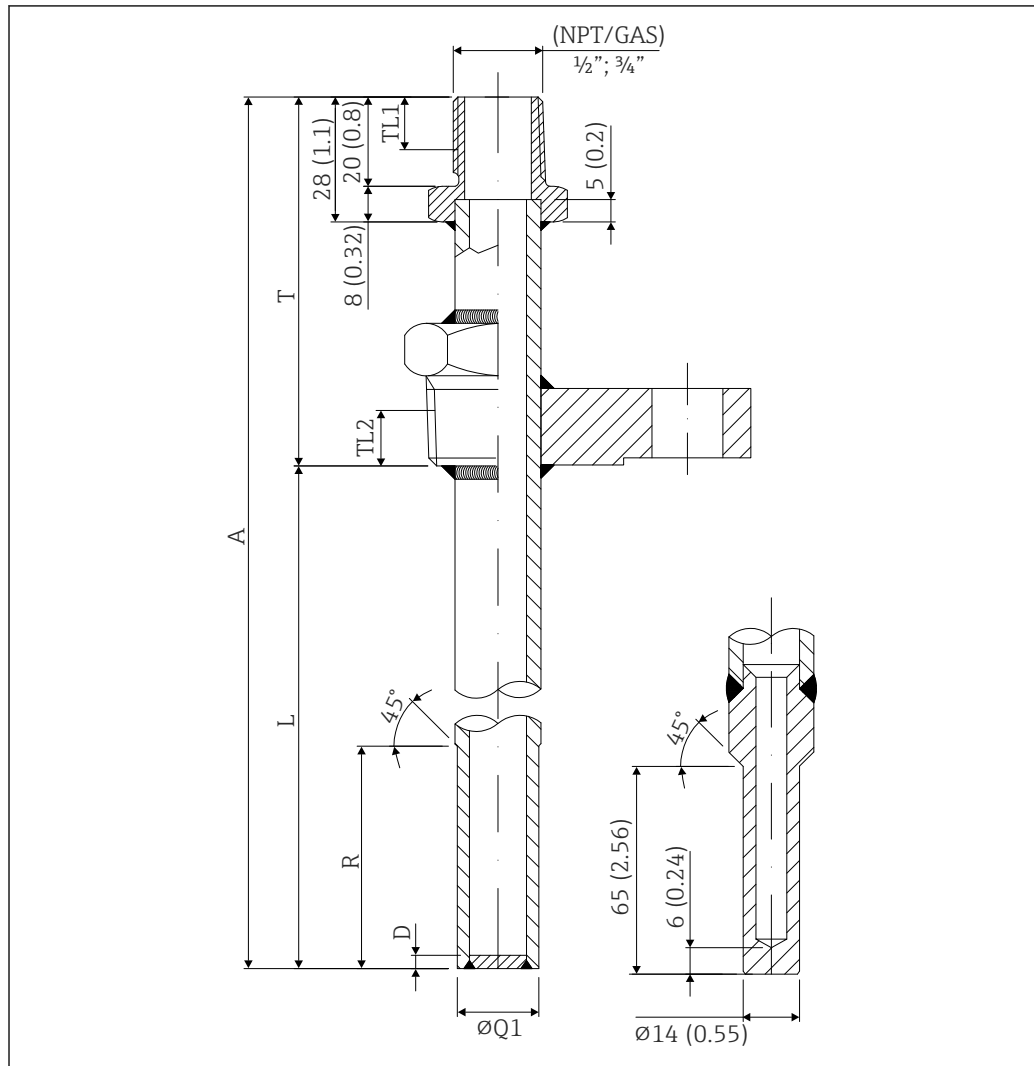

A0014039

2 Protection tube dimensions of the TA541 in mm (in)

Pos. no.	Description		
A	Total length, freely selectable		
L	Immersion length, freely selectable		
T	Extension, 95 mm (3.74 in); 120 mm (4.72 in) or freely selectable		
D	Bottom thickness		
ØQ1	Diameter protection tube tip		
R	Length of protection tube tip		
TL1	Thread length for thread connection on thermometer	Length in mm (in)	Thread
		20 mm (0.8 in)	G $\frac{1}{2}$ ", G $\frac{3}{4}$ "
		8 mm (0.32 in)	$\frac{1}{2}$ " NPT
		8.5 mm (0.33 in)	$\frac{3}{4}$ " NPT
TL2	Thread length for thread connection on process	Length in mm (in)	Thread
		8.5 mm (0.33 in)	$\frac{3}{4}$ " NPT
		10 mm (0.4 in)	1" NPT
		10.5 mm (0.41 in)	1 $\frac{1}{2}$ " NPT

## Installation conditions

### Orientation

No restrictions.

### Installation instructions

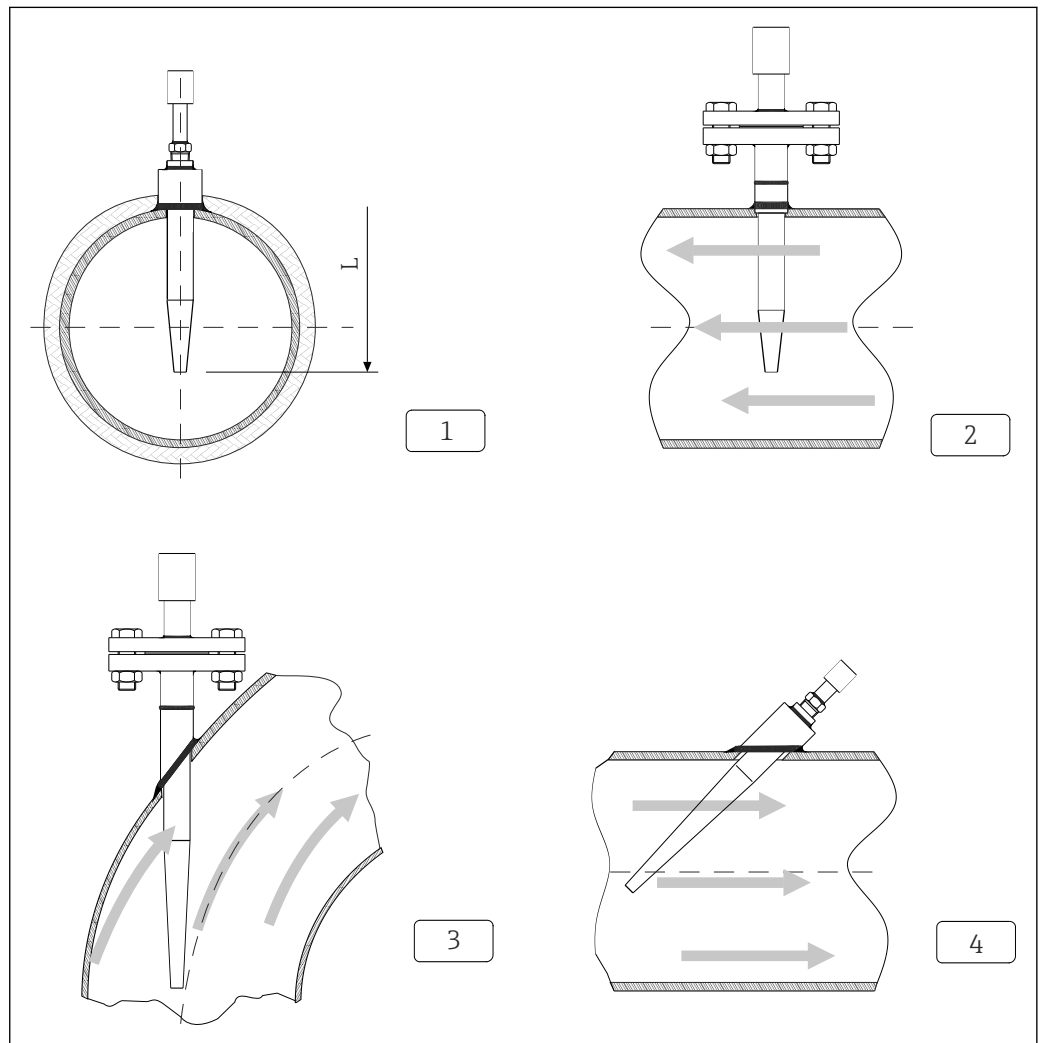

A0023441

#### 3 Installation examples

1-2 In pipes with a small cross section the sensor tip should reach or extend slightly past the center line of the pipe (= L)

3-4 Tilted installation

The immersion length of the thermometer influences the accuracy. If the immersion length is too small then errors in the measurement are caused by heat conduction via the process connection and the container wall. If installing into a pipe then the immersion length should be half of the pipe diameter, if possible (see 1 and 2). A further solution could be an angled (tilted) installation (see 3 and 4). When determining the immersion length all thermometer parameters and the process to be measured must be taken into account (e.g. flow velocity, process pressure).

- Installation possibilities: Pipes, tanks or other plant components
- Recommended minimum immersion length = 80 to 100 mm (3.15 to 3.94 in)  
The immersion length should correspond to at least 8 times of the thermowell diameter.
- ATEX certification: Always take note of the installation regulations.

---

## Certificates and approvals

---

**PED approval**

The thermowell complies with paragraph 3.3 of the Pressure Equipment Directive (97/23/EC) and is not marked separately.

**Test on thermowell**

Thermowell pressure tests are carried out in accordance with the specifications in the DIN 43772 standard. With regards to thermowells with tapered or reduced tips that do not comply with this standard these are tested using the pressure of corresponding straight thermowells. Tests according to other specifications can be carried out on request. Dye penetration tests verify the absence of cracks on the thermowell welding.

## Ordering information

Detailed ordering information is available from the following sources:

- In the Product Configurator on the Endress+Hauser website: [www.endress.com](http://www.endress.com) → Select country → Instruments → Select device → Product page function: Configure this product
- From your Endress+Hauser Sales Center: [www.endress.com/worldwide](http://www.endress.com/worldwide)

**Product Configurator - the tool for individual product configuration**

- Up-to-the-minute configuration data
- Depending on the device: Direct input of measuring point-specific information such as measuring range or operating language
- Automatic verification of exclusion criteria
- Automatic creation of the order code and its breakdown in PDF or Excel output format
- Ability to order directly in the Endress+Hauser Online Shop



## Accessories

### Service-specific accessories

Accessories	Description
Applicator	<p>Software for selecting and sizing Endress+Hauser measuring devices:</p> <ul style="list-style-type: none"> <li>▪ Calculation of all the necessary data for identifying the optimum measuring device: e.g. pressure loss, accuracy or process connections.</li> <li>▪ Graphic illustration of the calculation results</li> </ul> <p>Administration, documentation and access to all project-related data and parameters over the entire life cycle of a project.</p> <p>Applicator is available:</p> <ul style="list-style-type: none"> <li>▪ Via the Internet: <a href="https://wapps.endress.com/applicator">https://wapps.endress.com/applicator</a></li> <li>▪ On CD-ROM for local PC installation.</li> </ul>
Konfigurator <sup>+temperature</sup>	<p>Software for selecting and configuring the product depending on the measuring task, supported by graphics. Includes a comprehensive knowledge database and calculation tools:</p> <ul style="list-style-type: none"> <li>▪ For temperature competence</li> <li>▪ Quick and easy design and sizing of temperature measuring points</li> <li>▪ Ideal measuring point design and sizing to suit the processes and needs of a wide range of industries</li> </ul> <p>The Konfigurator is available:</p> <p>On request from your Endress+Hauser sales office on a CD-ROM for local PC installation.</p>
W@M	<p>Life cycle management for your plant</p> <p>W@M supports you with a wide range of software applications over the entire process: from planning and procurement, to the installation, commissioning and operation of the measuring devices. All the relevant device information, such as the device status, spare parts and device-specific documentation, is available for every device over the entire life cycle.</p> <p>The application already contains the data of your Endress+Hauser device. Endress+Hauser also takes care of maintaining and updating the data records.</p> <p>W@M is available:</p> <ul style="list-style-type: none"> <li>▪ Via the Internet: <a href="http://www.endress.com/lifecyclemanagement">www.endress.com/lifecyclemanagement</a></li> <li>▪ On CD-ROM for local PC installation.</li> </ul>



---

[www.addresses.endress.com](http://www.addresses.endress.com)

---