

Technical Information

Tank Side Monitor NRF590

Inventory Control

Field device for tank sensor operation and monitoring and for integration into inventory control systems



Software Version 02.04.zz

Application

The Tank Side Monitor NRF590 is a sensor integration and monitoring unit for bulk storage tank gauging applications. It can be used with Micropilot radar or Proservo level gauges and can be combined with other HART compatible devices.

The Tank Side Monitor offers the following functions:

- intrinsically safe (i.s.) power supply of the connected devices
- parametrization of the connected devices
- display of the measured values
- tank calculations for accurate correction of the tank distortions

Features and benefits

- I.s. power supply and communication for Micropilot and Levelflex level radars
- Connects up to 6 HART devices via i.s. 2 wire, for example Prothermo for average temperature measurement and Cerabar/Deltabar for HTMS density applications
- Backlit graphical LCD display; operation via 3 optical keys (touch control)
- User-friendly operating menu (multi-lingual)
- Interfaces to the tank inventory system Tankvision
- Provides communication to PLC, DCS and SCADA systems
- Various industry standard communication protocols, including
 - **Sakura V1**
 - **EIA-485 Modbus**
 - **Whessoematic WM550**
 - **BPM (compatible with Enraf systems)**
- Approved for use in explosion hazardous areas
- Weights & Measure-approved for use in custody transfer applications

Table of Contents

Function and system design	3	Storage temperature	21
Application	3	Ingress protection	21
Operating principle	3	Electromagnetic compatibility (EMC)	21
System Integration		Overvoltage protection	21
(typical example)	3		
HART interface	4	Mechanical construction	22
Power supply for HART instruments	4	Design, dimensions	22
Operation of HART instruments	4	Material	22
Typical Tank calculations	5	Construction	22
Corrections	7	Weight	22
Overfill protection	7	Cable entries	22
Inputs and outputs	8	Human interface	23
Non IS inputs and outputs	8	Display and operating elements	23
IS inputs and outputs	8	Operating concept	25
Fieldbus Protocols	9	Remote operation	25
Values transmitted by the Field Protocols	10		
Technical data of the non-IS inputs and outputs	11	Certificates and Approvals	26
Technical Data of the IS inputs and outputs	12	CE mark	26
		Ex approvals	26
Auxiliary energy	13	Custody transfer approvals	26
AC supply	13	External standards and guidelines	27
DC supply	13		
Power consumption	13	Ordering information	28
Inrush current	13	Tank Side Monitor NRF590	28
Fuse	13		
Grounding	13	Accessories	30
		Discrete I/O modules	30
Electrical connection - non-i.s. terminals	14	Rail mounting kit	33
Terminal assignment of the field protocol/host side	14		
Connection of the field protocols	15	Supplementary Documentation	34
Grounding of the fieldbus screen	15	Technical Information	34
Connection of the auxiliary energy	15	Operating Instructions	34
Connection of the non-i.s.		Safety Instructions	34
4 to 20 mA analogue input	16	Control Drawings	34
Connection of the non-i.s.		35
4 to 20 mA analogue output	16	36
Connection of the discrete in and output	16		
Electrical connection - i.s. terminals	17		
Terminal assignment	17		
Connection of HART instruments	18		
Spot RTD	19		
Performance characteristics	19		
Accuracy	19		
Resolution	19		
Scan time	19		
Installation conditions	20		
Wall mounting	20		
Mounting on vertical rail	20		
Mounting on horizontal rail	20		
Ambient conditions	21		
Ambient temperature	21		

Function and system design

Application

The Tank Side Monitor NRF590 is a field device for the integration of tank sensors into tank inventory systems. It is used in tank farms, terminals and refineries. Especially, it can be used in connection with Micropilot M level radars (for inventory control) and Micropilot S high accuracy level radars (for custody transfer applications).

Operating principle

The Tank Side Monitor is typically installed at the bottom of the tank and allows to access all connected tank sensors. Typical process values measured by the sensors are:

- level
- temperature (point and/or average)
- water level (measured by capacitive probe)
- hydrostatic pressure (for hydrostatic tank gauging, "HTG", or hybrid tank measurements, "HTMS")
- secondary level value (for critical applications)

The Tank Side Monitor collects the measured values and performs several configurable tank calculations.

All measured and calculated values can be displayed at the on-site display. Via a field communication protocol, the Tank Side Monitor can transfer the values to an inventory control system.

System Integration (typical example)

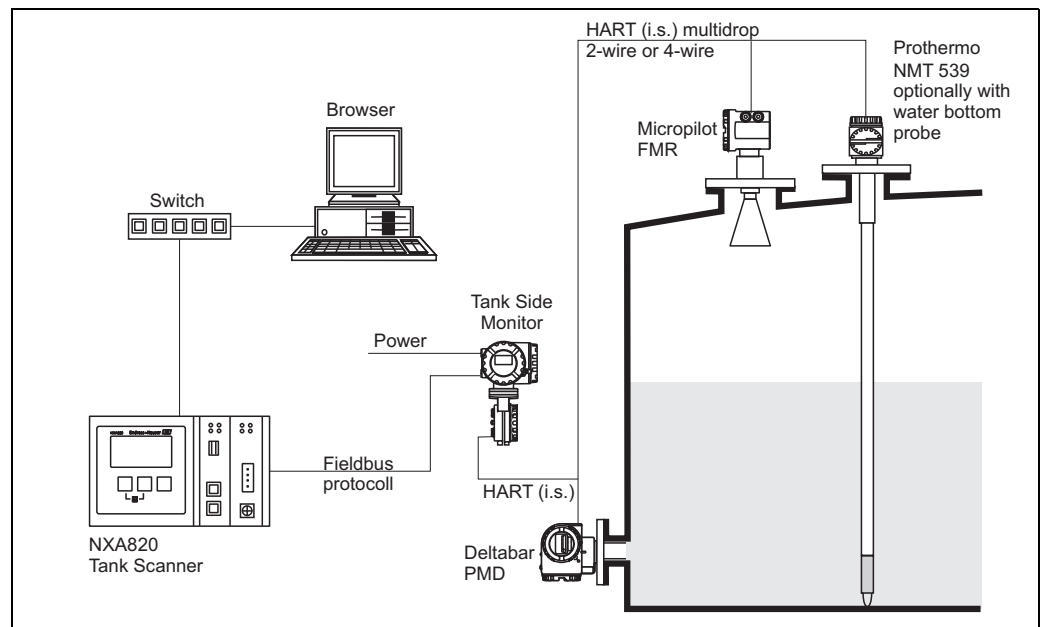

HART interface

IS (intrinsically safe)	HART Master for measuring device connection
Non-IS (if selected by order code)	user settable: <ul style="list-style-type: none">■ HART Master■ HART Slave (active 4-20 mA when address is "0")

Power supply for HART instruments

The Tank Side Monitor provides intrinsically safe power for 2-wire tank sensors. It also can provide intrinsically safe power for the 4-wire instrument Micropilot S.

Operation of HART instruments

For the following instruments, the operating menu can be accessed on the display of the Tank Side Monitor:

- Micropilot M: FMR230/231/240/244/245
- Micropilot S: FMR530/531/532/533/540
- Prothermo: NMT532/535/536/537/538
- Prothermo: NMT539 (including Water Bottom Probe)
- Cerabar M: PMC/PMP4x
- Cerabar S: PMC/PMP7x
- Cerabar: PCM/PMC73x/63x
- Deltabar: PMD/FMD23x/63x
- Deltabar S: PMD/FMD7x

Any other HART instrument can be operated via the Generic HART menu (allowing all 4 universal HART values to be accessed).

Typical Tank calculations

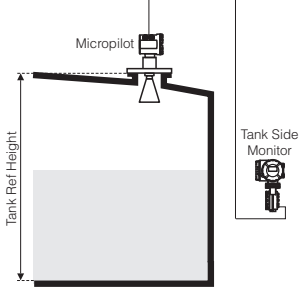
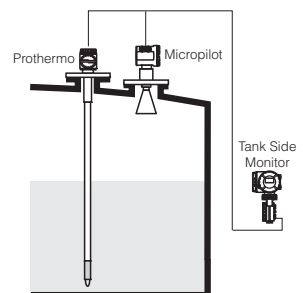
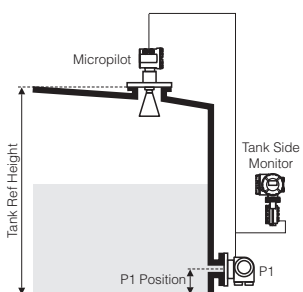
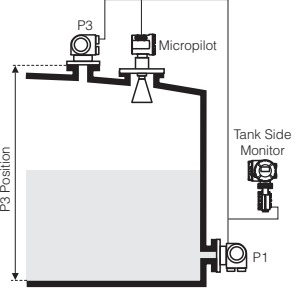
Setup preset	Installation example	Sensors	measured/ calculated values	required parameters
Direct level measurement				
Level only	 <p style="text-align: center;">L00-NRF590-14-00-08-yy-002</p>	<ul style="list-style-type: none"> Level sensor 	<ul style="list-style-type: none"> level 	<ul style="list-style-type: none"> Tank Ref Height
Level + Temperature	 <p style="text-align: center;">L00-NRF590-14-00-08-yy-003</p>	<ul style="list-style-type: none"> Level sensor Temperature sensor (RTD or HART device; optionally with bottom water probe) 	<ul style="list-style-type: none"> level temperature 	
Hybrid Tank Measuring System (HTMS)				
HTMS + P1	 <p style="text-align: center;">L00-NRF590-14-00-08-yy-004</p>	<ul style="list-style-type: none"> Level sensor Pressure sensor (P1, bottom) 	<ul style="list-style-type: none"> level density of the measured medium (calculated) 	<ul style="list-style-type: none"> Tank Ref Height P1 Position Min HTMS (minimum level at which HTMS measurement is possible; should be slightly above the position of the P1 sensor) local gravity vapour density air density P3 Position (only for the "HTMS + P1,3" mode)
HTMS + P1,3	<p>Note! This mode should be used in non-atmospheric tanks (e.g. pressurised tanks)</p>  <p style="text-align: center;">L00-NRF590-14-00-08-yy-005</p>	<ul style="list-style-type: none"> Level sensor Pressure sensor (P1, bottom) Pressure sensor (P3, top) 		

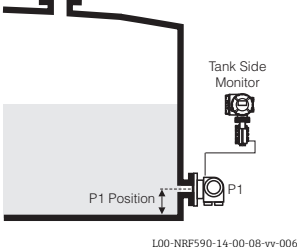
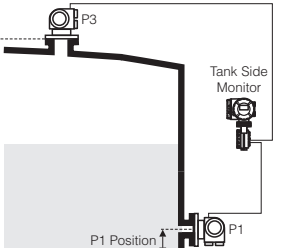
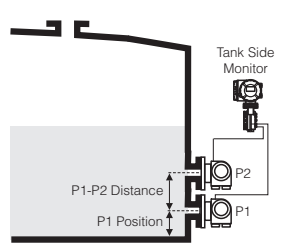
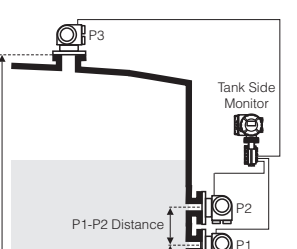
Setup preset	Installation example	Sensors	measured/ calculated values	required parameters
Hydrostatic Tank Gauging (HTG)				
HTG P1	 <p>L00-NRF590-14-00-08-yy-006</p>	<ul style="list-style-type: none"> Pressure sensor (P1, bottom) 	<ul style="list-style-type: none"> level (calculated) 	<ul style="list-style-type: none"> Tank Ref Height local gravity density of the measured medium Min HTG Level (minimum level at which HTG measurement is possible; should be slightly above the position of the P1 sensor) P1 Position P3 Position (only for the "HTG P1,3" mode)
HTG P1,3	<p>Note! This mode should be used in non-atmospheric tanks (e.g. pressurised tanks)</p>  <p>L00-NRF590-14-00-08-yy-009</p>	<ul style="list-style-type: none"> Pressure sensor (P1, bottom) Pressure sensor (P3, top) 		
HTG P1,2	 <p>L00-NRF590-14-00-08-yy-007</p>	<ul style="list-style-type: none"> Pressure sensor (P1, bottom) Pressure sensor (P2, middle) 	<ul style="list-style-type: none"> level (calculated) density of the measured medium (calculated) 	<ul style="list-style-type: none"> Tank Ref Height local gravity Min HTG Level (minimum level at which HTG measurement is possible; should be slightly above the position of the P2 sensor) P1 Position P1-P2-Distance P3 Position (only for the "HTG P1,2,3" mode)
HTG P1,2,3	<p>Note! This mode should be used in non-atmospheric tanks (e.g. pressurised tanks)</p>  <p>L00-NRF590-14-00-08-yy-008</p>	<ul style="list-style-type: none"> Pressure sensor (P1, bottom) Pressure sensor (P2, middle) Pressure sensor (P3, top) 		

Corrections

The Tank Side Monitor can automatically calculate the following corrections:

- Correction for the Hydrostatic Tank Deformation (HyTD)
- Temperature Correction for Thermal Expansion of the Tank Shell (CTSh)

Overfill protection

The NRF590 can be configured and used as part of an overfill protection system in conjunction with the approved WHG operating mode of the Endress+Hauser FMR53x/54x radar devices (as described in the TÜV test certificate for the FMR53x/54x WHG operating mode).

Overview

- Level input from FMR53x/54x via HART communication
- Discrete output via DO #A and/or DO #B (in conjunction with the AL1 alarm function block)
- Analogue 4 to 20mA output via AO

Note!

AO #2 and DO #C (if available) cannot be used for overfill protection

Inputs and outputs

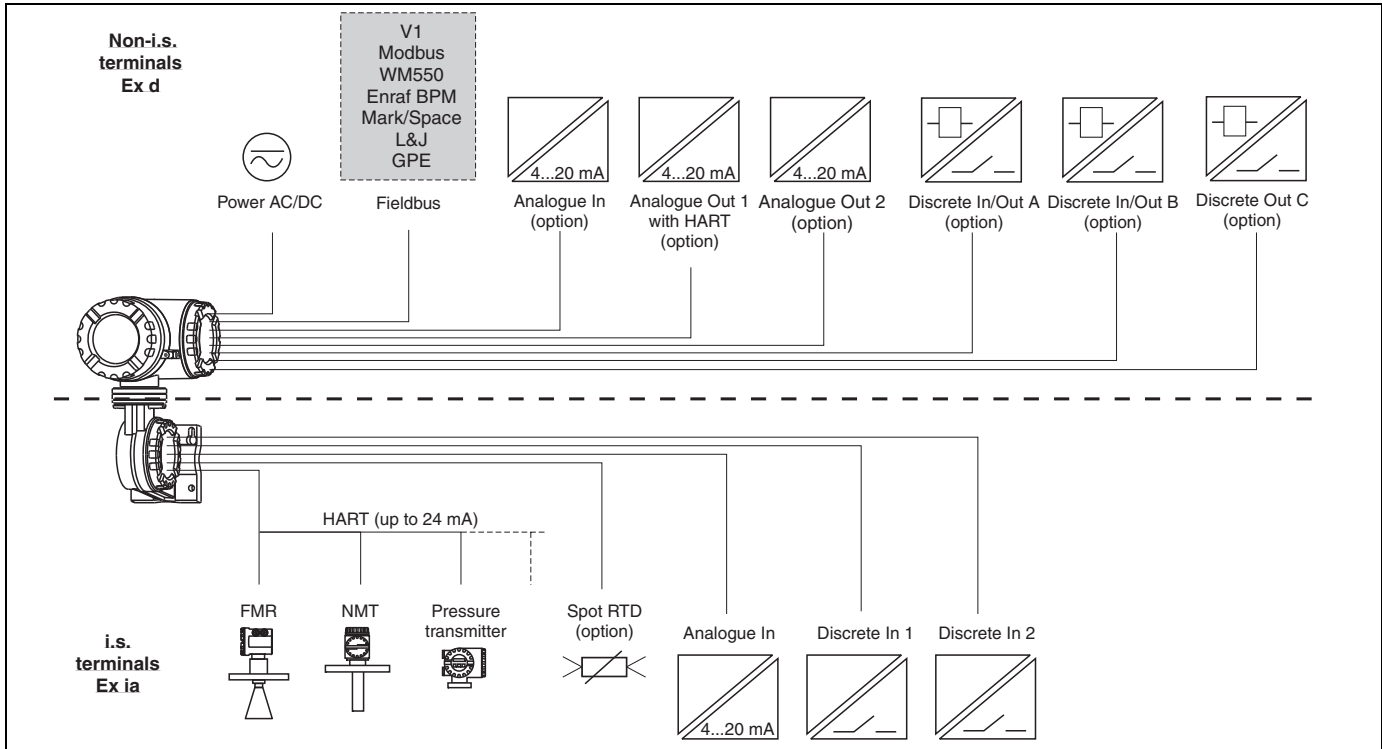

L00-NRF590-04-08-08-en-003

Non IS inputs and outputs

		V1	Modbus	WM550	BPM	Mark/Space	L&J Tankway	GPE
Analogue In	AI	-	option ¹⁾	-	standard	standard	standard	-
Analogue Out 1	AO	standard +HART	option ¹⁾ +HART	standard +HART	standard +HART	standard +HART	standard +HART	standard +HART
Analogue Out 2	AO#2	standard	-	standard	-	-	-	standard
Discrete In/Out A	DI#A DO#A	option, s. pos. 50 of the product structure						
Discrete In/Out B	DI#B DO#B	option, s. pos. 60 of the product structure						
Discrete Out C	DO#C	standard	-	-	-	-	-	-

1) see pos. 20 option 4 of the product structure; Modbus without in- or output does **not** provide an Ex d HART bus!

IS inputs and outputs

		V1	Modbus	WM550	BPM	Mark/Space	L&J Tankway	GPE
HART		standard	standard	standard	standard	standard	standard	standard
IS RTD		option, s. pos. 40 of the product structure						
IS Discrete In 1	IS DI#1	standard	standard	standard	standard	standard	standard	standard
IS Discrete In 2	IS DI#2	standard	standard	standard	standard	standard	standard	standard
IS Analogue In	IS AI	standard	standard	standard	standard	standard	standard	standard

Fieldbus Protocols

The Tank Side Monitor NRF590 supports all of the following industry standard communication protocols allowing it to be integrated with existing instrumentation and connect to host computer systems without the need for additional hardware. These protocols allow for piece-by-piece replacement and upgrading of older technologies to modern radar solutions.

Sakura V1

V1 protocol provides a standard form of digital communication via a two-wire system. V1 was brought to the market by Sakura Endress and meets the demands of the Japanese market.

The Tank Side Monitor implementation of the V1 slave protocol supports various old and new V1 protocols:

- V1 (new V1)
- MDP (old V1)
- BBB (old V1)
- MIC+232 (old V1) (in preparation)

EIA-485 (RS485) Modbus

In Modbus, the flow of data between two devices uses a master/slave protocol. The NRF590 acts as a Modbus slave and runs on the EIA-485 (RS) version of the MODBUS communications board. Modbus provides Varec MFT parameter mapping for easier setup in retrofit applications. It provides direct connection to PLC and DCS systems.

Whessoematic WM550

The WM550 protocol provides a standard form of digital communication via dual current loops. WM550 was developed by Endress+Hauser (formerly Whessoe) to facilitate communications to transmitters installed on mechanical float and tape gauges. It is a two-wire system and the only protocol with a redundant loop.

BPM

The Bi-Phase Mark (BPM) protocol provides compatibility to Enraf systems by emulating the Enraf GPU-BPM protocol. The NRF590 is fully compatible to ENRAF (802, 812), 811, 854 and 954 series servo gauges, 813 MGT (mechanical gauge transmitter), 872, 873 and 973 series Radar gauges, 874 AIM (Analogue Input Module) and the 875 VCU (Valve Command Unit).

Mark/Space

The Mark/Space protocol provides compatibility with Varec transmitters using a standard form of digital communication via a voltage mode bus. Mark/Space was developed to facilitate communication to transmitters installed on mechanical float and tape gauges. It supports product level, temperature and discrete inputs.

L&J Tankway

L&J Tankway protocol provides a standard form of digital communication via a voltage mode bus. Tankway supports product level, temperature and discrete inputs.

GPE

GPE protocol provides a standard form of digital communication via a current loop. It is compatible with L&J and GPE mechanical float and tape and servo instrumentation.

Values transmitted by the Field Protocols

The following values can be transmitted by the communication protocols:

Tank Value	Symbol	V1 - old	V1 - new	Modbus	WM550	BPM	Mark/Space	L&J Tankway Basic	L&J Tankway Servo	GPE
Level	L	yes	yes	yes	yes	yes	yes	yes	yes	yes
Temperature (Product)	T _P	yes	yes	yes	yes	yes	yes	yes	yes	yes
Observed Density	D _{obs}	-	yes	yes	yes	yes	-	-	yes	-
Water Level	L _W	-	yes	yes	yes	yes	-	-	yes	-
Pressure 1 (Bottom)	P ₁	-	yes	yes	yes ¹⁾	yes	-	-	-	-
Pressure 2 (Middle)	P ₂	-	yes	yes	yes ¹⁾	-	-	-	-	-
Pressure 3 (Top)	P ₃	-	yes	yes	yes	yes	-	-	-	-
Measured Level	L _M	-	-	yes	yes ¹⁾	-	-	-	-	-
Level Correction	L _C	-	-	yes	yes ¹⁾	-	-	-	-	-
Percentage Level	L _%	-	-	yes	yes	-	-	-	-	-
Gasphase Temperature	T _V	-	yes	yes	yes ¹⁾	yes	-	-	-	-
Air Temperature	T _A	-	-	yes	yes ¹⁾	yes	-	-	-	-
General Purpose Value 1	GP ₁	-	yes	yes	yes ¹⁾	-	-	-	-	-
General Purpose Value 2	GP ₂	-	yes	yes	yes ¹⁾	-	-	-	-	-
General Purpose Value 3	GP ₃	-	-	yes	yes ¹⁾	-	-	-	-	-
General Purpose Value 4	GP ₄	-	-	yes	yes ¹⁾	-	-	-	-	-
Multi-Element Temperatures	T ₍₁₎ to T ₍₁₆₎	-	yes	yes	T ₍₁₎ to T ₍₁₅₎	-	-	-	-	-
Alarm/Discrete Values		yes ²⁾	yes ²⁾	yes	yes	yes ³⁾	yes ⁴⁾	yes ⁵⁾	yes ⁵⁾	-
Discrete Output Control		-	-	yes	-	-	-	-	-	1
Additional		-	4-20mA ⁶⁾	yes	Level %	-	-	Temp ⁷⁾	-	4-20mA ⁶⁾
Protocol Documentation		KA00246 F	KA00246 F	KA00245 F	KA00247 F	KA00248 F	KA00249 F	KA00250 F	KA00250 F	KA00251 F

1) Only accessible through WM550 extended tasks (51&52); not available on older control room systems.

2) The protocol allows 2 alarm and 4 general purpose flags which can be connected to any alarm or discrete input.

3) Level L & H alarm, 4 alarms and 2 general purpose flags which can be connected to any alarm or discrete input.

4) The protocol allows 2 digital alarm values which can be connected to any alarm or discrete input.

5) The protocol allows 2 digital values which can be connected to any alarm or discrete input.

6) One additional value "4-20mA" which can be connected to any value, however range of value sent is limited (see KA00246F/00/EN).

7) One additional value "Temp2" which can be connected to any value, however the range of value sent is limited (see KA00250F/00/EN).

Technical data of the non-IS inputs and outputs**Analogue 4 to 20 mA input (option, s. pos. 20 of the product structure)**

Internal load (to ground)	110 Ω
Measuring range	0 to 26 mA
Accuracy	$\pm 15 \mu\text{A}$ (after linearisation and calibration)

Analogue 4 to 20 mA outputs

Output current	3 to 24 mA
Output voltage	$U = 24 \text{ V} - I_{\text{LOAD}} 400 \Omega$
Output load	max. 500 Ω
Accuracy	$\pm 15 \mu\text{A}$ (after linearisation and calibration)
HART options ¹⁾	<ul style="list-style-type: none">■ Slave, address # 0: 4 to 20 mA active■ Slave, address #1 - #15: fixed current (user selectable)■ Master: max. current ($\leq 24 \text{ mA}$) selectable by user; typically 6 HART instruments (each 4 mA) can be connected²⁾

- 1) The second analogue output (available for V1, WM550 and GPE) has no HART option.
- 2) Start-up current of the HART instruments has to be taken into account

Discrete inputs/outputs A and B

The Tank Side Monitor can be equipped with 1 or 2 discrete I/O modules.
Available types: see position 50 and 60 of Product Structure or chapter "Accessories".

Discrete output C (for V1 protocol)

Load voltage	3 to 100 V
Load current	max. 500 mA
Type of contact	mechanical latching relay
Isolation voltage	1500 V
Approvals	UL, CSA

Technical Data of the IS inputs and outputs

HART input loop

Source voltage	$U = 25 \text{ V} - I_{\text{Load}} \times 333 \ \Omega$ (typically)
total I_{max}	Start-up currents of all connected HART devices may not exceed a total of 27 mA
connectable sensors	depending on current consumption (including start-up current)

Spot RTD input (option, s. pos. 40 of the product structure)

Measuring range	10...600 Ω
Excitation current	typ. 400 μA , max. 2000 μA

Type of Sensor	Nominal value	Temp _{min}	Temp _{max}	Accuracy ¹⁾
Pt100 (385) IEC751 Pt100 (389) Pt100 (392) IPTS-68	100 Ω @ 0 °C (\approx 32 °F)	-200 °C (\approx -330 °F)	+600 °C (\approx +1110 °F)	± 0.1 °C (\approx ± 0.2 °F)
Cu90 (4274)	100 Ω @ 25 °C (\approx 77 °F) [90 Ω @ 0 °C (\approx 32 °F)]	-100 °C (\approx -150 °F)	+250 °C (\approx +480 °F)	± 0.1 °C (\approx ± 0.2 °F)
Ni120 (672)	120 Ω @ 0 °C (\approx 32 °F)	-60 °C (\approx -75 °F)	+180 °C (\approx +350 °F)	± 0.1 °C (\approx ± 0.2 °F)
Ni100 (618) DIN 43760	100 Ω @ 0 °C (\approx 32 °F)	-60 °C (\approx -75 °F)	+180 °C (\approx +350 °F)	± 0.1 °C (\approx ± 0.2 °F)

1) Accuracy of converter, may be influenced by element accuracy

IS Analogue 4 to 20 mA input (option, s. pos. 70 of the product structure)

Source voltage	$U = 25 \text{ V} - I_{\text{Load}} \times 333 \ \Omega$ (typically)
Internal load (to ground)	100 Ω
Measuring range	0 to 26 mA
Accuracy	$\pm 15 \ \mu\text{A}$ (after linearisation and calibration)
Usage	Source for Discrete Inputs / Source for 4 to 20 mA loop device

Discrete inputs (option, s. pos. 70 of the product structure)

Active voltage ("closed circuit")	min. 9 V (default)
In-active voltage ("open circuit")	max. 7 V (default)
Active high current	4 mA
Switching hysteresis	2 V

Auxiliary energy

AC supply 55 to 264 VAC; insensitive to polarity / CSA approved: 55 to 250 VAC

DC supply 18 to 55 VAC/DC

Power consumption

- 370 mA at 24 V DC
- 200 mA at 48 V DC
- 75 mA at 125 V AC
- 45 mA at 220 V AC

Inrush current 30 A, duration 0.6 ms

Fuse Internal (on primary power)

Grounding The NRF590 must be grounded to the tank potential before communication and power connections are made. The connections ($A \geq 4 \text{ mm}^2$) from each outer ground plug of the NRF590 to the tank ground must be made before any other wiring connections are made. All grounding must be compliant with local and company regulations and checked before the equipment is commissioned.

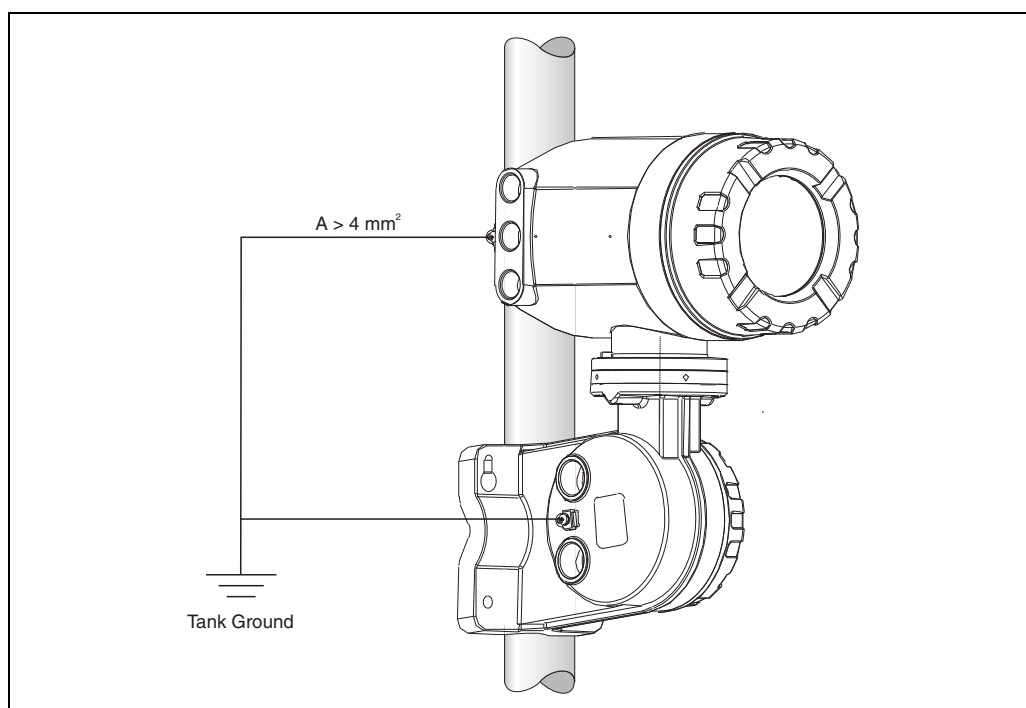

L00-NRF590-04-08-08-en-004

Electrical connection - non-i.s. terminals

Terminal assignment of the field protocol/host side

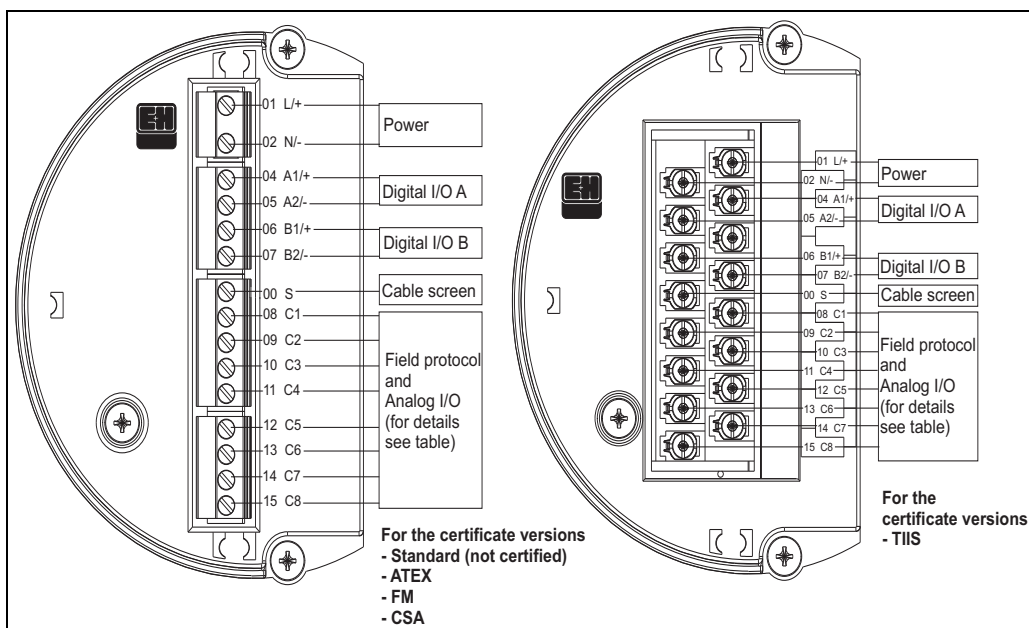

Terminal	01 L/+	02 N/-	04 A1/+	05 A2/-	06 B1/+	07 B2/-	00 S
	Power supply		Discrete I/O - A +	Discrete I/O - A -	Discrete I/O - B +	Discrete I/O - B -	Cable screen

	08 C1	09 C2	10 C3	11 C4	12 C5	13 C6	14 C7	15 C8
V1	4 to 20 mA output ¹⁾ #2	V1A	V1B	0 V ¹⁾	0 V	4 to 20 mA output #1 + HART	discrete output 1C	discrete output 2C
EIA-485 Modbus	not used ²⁾	485-B	485-A	0 V	0 V ¹⁾	4 to 20 mA output ³⁾ +HART	4 to 20 mA input ³⁾	+24 V ¹⁾
Whessoe WM550	4 to 20 mA output ¹⁾ #2	Loop 1-	Loop 1+	0 V ¹⁾	0 V	4 to 20 mA output #1 +HART	Loop 2-	Loop 2+
BPM	not used ²⁾	T	T	0 V	0 V ¹⁾	4 to 20 mA output + HART	4 to 20 mA input	+24 V ¹⁾
Mark/Space	V+	Space	Mark	0 V (V-)	0 V ¹⁾	4 to 20 mA output + HART	4 to 20 mA input	+24 V ¹⁾
L&J Tankway	Power	Encoder	Computer	Ground	0 V ¹⁾	4 to 20 mA output + HART	4 to 20 mA input	+24 V ¹⁾
GPE	4 to 20 mA output ¹⁾ #2	Loop 1-	Loop 1+	0 V ¹⁾	0 V	4 to 20 mA output #1 + HART	do not connect	do not connect

1) In case an "Ex d" rated 4-wire level gauge version is used, the power supply can be obtained from these terminals (21V ±10%).

2) The internal voltage at this terminal is 0 V, however, shielding and signal common should be connected to terminal 11 or 12.

3) Option, s. pos. 20 of the product structure

Connection of the field protocols**Sakura V1**

The V1 protocol provides 2 wire communication allowing up to 10 devices to operate on a loop. V1 connects to terminals 9-10. Max. distance: 6000 m

EIA-485 Modbus

The NRF590 protocol uses a shielded 3-wire EIA-485 hardware interface to communicate with the modbus master. EIA-485 is a high speed, differential communications network that allows up to 32 devices to operate on one network.

- Using one shielded twisted pair of 18 AWG wire, connect the EIA-485 at terminal 9 and 10.
- Termination of the EIA-485 bus at the NRF590 can be set in the operating menu (only enable on end device in a loop)
- Connect the 3rd wire from the control system signal common (0V) to terminal 11 or 12.
- Max distance: 4000 ft (1300 m)

Whessoematic WM550

The WM550 protocol provides 2 wire, current loop communication and allows up to 16 devices per loop.

For redundancy (safety function) two wire pairs are used. They always transmit the same values. The WM550-loops connect to terminals 9 - 10 and 14 - 15. Max. distance: 7000 m

BPM

The BPM protocol provides 2 wire communication allowing up to 10 devices to operate on a loop. BPM connects to terminals 9-10. Max. distance: 10000 m

Mark/Space

For a NRF590 using the Mark/Space field communications option, the following additional wiring connections must be made:

- Run 2 twisted pairs (one power, one communication) of 18 AWG wire (Mark/Space wires) into the upper terminal compartment through one of the conduit entries along with the 48 Vdc power wiring.
- Connect the Mark line to terminal 10 and the Space line to terminal 9.
- Connect to power supply at terminals 8 and 11.

L&J Tankway

Including power and ground, L&J is a 4-wire system, allowing 50+ devices to be connected on the communication bus. L&J connects to terminals 8 through 11.

GPE

The GPE protocol provides 2 wire current loop communication. GPE connects to terminal 9-10.

Grounding of the fieldbus screen

The screen of the fieldbus cable should be connected to ground at both ends. If this is not possible due to signal disruption by potential equalisation currents, it is advisable to connect the screen of the fieldbus cable to terminal "00 S" at the NRF590 and to ground at the other end. The "00S" terminal provides a 500 V capacitor between the cable screen and tank ground potential.

Connection of the auxiliary energy

The Tank Side Monitor can be AC or DC supplied, depending on the installed power supply board. The AC supply needs to be connected to the terminals marked "L/+" (Line) and "N/-" (Neutral), corresponding with the phase/line and neutral wire. DC supply can be connected to the same terminals, for which it is necessary to connect the positive (+) to the terminal marked "L/+", and the negative to the terminal marked "N/-".

Connection of the non-i.s. 4 to 20 mA analogue input

Depending on the selected fieldbus communication board, a non-i.s. self-powered or loop powered analogue transmitter can be connected. The analogue signal for the loop powered transmitter can be connected to the terminals 14 (-) and 15 (+24 V DC). The maximum supply current for the analogue transmitter is limited to 24 mA. The analog signal for a self powered transmitter should be connected to terminals 11 or 12 and 14.

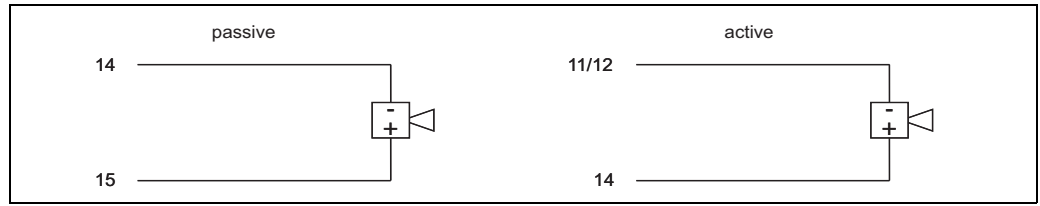

L00-NRF590-04-00-08-en-019

Connection of the non-i.s. 4 to 20 mA analogue output

For all field communication boards except the Modbus Option without analog in/output, a non-i.s. 4...20mA output is available. Via Software settings, this analogue output can be connected to any parameter in the Tank Side Monitor. The analogue output is available between terminals 13 (+) and 12 (-). From SW 02.01.xx onwards, an additional HART signal is available at terminal 13.

Connection of the discrete in and output

The Tank Side Monitor can be equipped with up to 2 discrete I/O modules. These modules can be used for interfacing to non-i.s. discrete in- or outputs. Input and output voltage and current ranges depend on the type of selected module installed in the relevant I/O slot. Terminals 4 and 5 correspond to discrete I/O slot A, terminals 6 and 7 correspond to discrete I/O slot B. For details on available I/O modules, → 30.

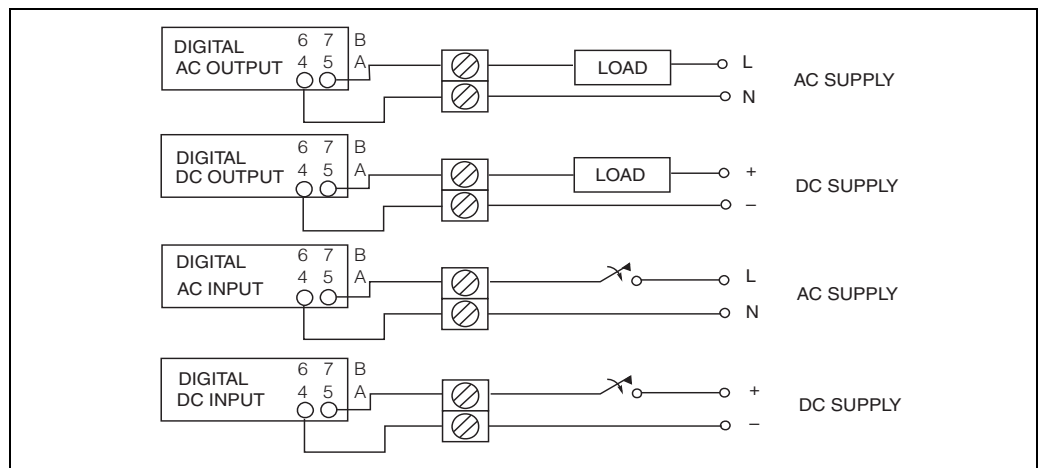

L00-NRF590-04-00-08-en-004

Note!
250 V AC is the maximum load that can be connected.

Electrical connection - i.s. terminals

Terminal assignment

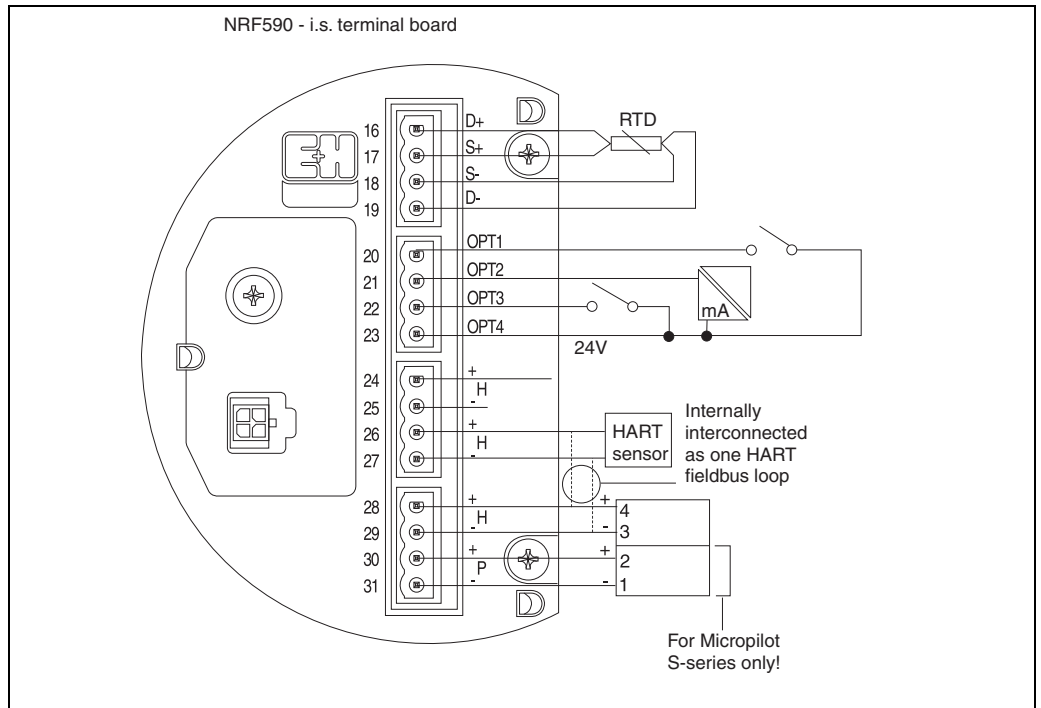

L00-NRF590-04-00-08-en-018

Terminal	Designation	Meaning
16	D+	+ RTD drive ¹⁾
17	S+	+ RTD sense ¹⁾
18	S-	- RTD sense ^{1), 2)}
19	D-	- RTD drive ^{1), 2)}
20	OPT1	Discrete Input 1
21	OPT2	Analog Input 1 (4 to 20 mA)
22	OPT3	Discrete Input 2
23	OPT4	Option +24 V
24	H+	+HART comm. ³⁾
25	H-	-HART comm. ⁴⁾
26	H+	+HART comm. ³⁾
27	H-	-HART comm. ⁴⁾
28	H+	+HART comm. ³⁾
29	H-	-HART comm. ⁴⁾
30	P+	+ i.s. power for FMR S-series (terminal 2 of FMR) ³⁾
31	P-	- i.s. power for FMR S-series (terminal 1 of FMR) ⁴⁾

- 1) These terminals should be left unconnected if RTD has not been selected in feature 40 of the product structure.
- 2) For a 3-wire RTD, terminals 18 and 19 should be connected together.
- 3) These terminals share the same HART signal.
- 4) These terminals share the same i.s. 0 V signal.

Connection of HART instruments

Tank sensors

The Tank Side Monitor can interface to a maximum of 6 i.s. HART sensors. All HART sensors are connected to one HART multi-drop communication loop. In order to keep wiring simple, 3 interconnected terminal pairs are available. The terminal pairs are marked respectively "H+" and "H-".

Power supply for Micropilot S

For supplying extra i.s. power to the FMR S-series radar, additional power terminals are available, marked as "P+" and "P-". Although it is possible to use only 3 wires between the S-series radar and the NRF590, by combining the "P-" and "H-" wires, it is recommended to use a double pair of screened and twisted cable.

Grounding of the cable screen (for Micropilot S)

The screen of the cable connecting the Micropilot S to the Tank Side Monitor should be grounded at the Tank Side Monitor, **not** at the Micropilot S.

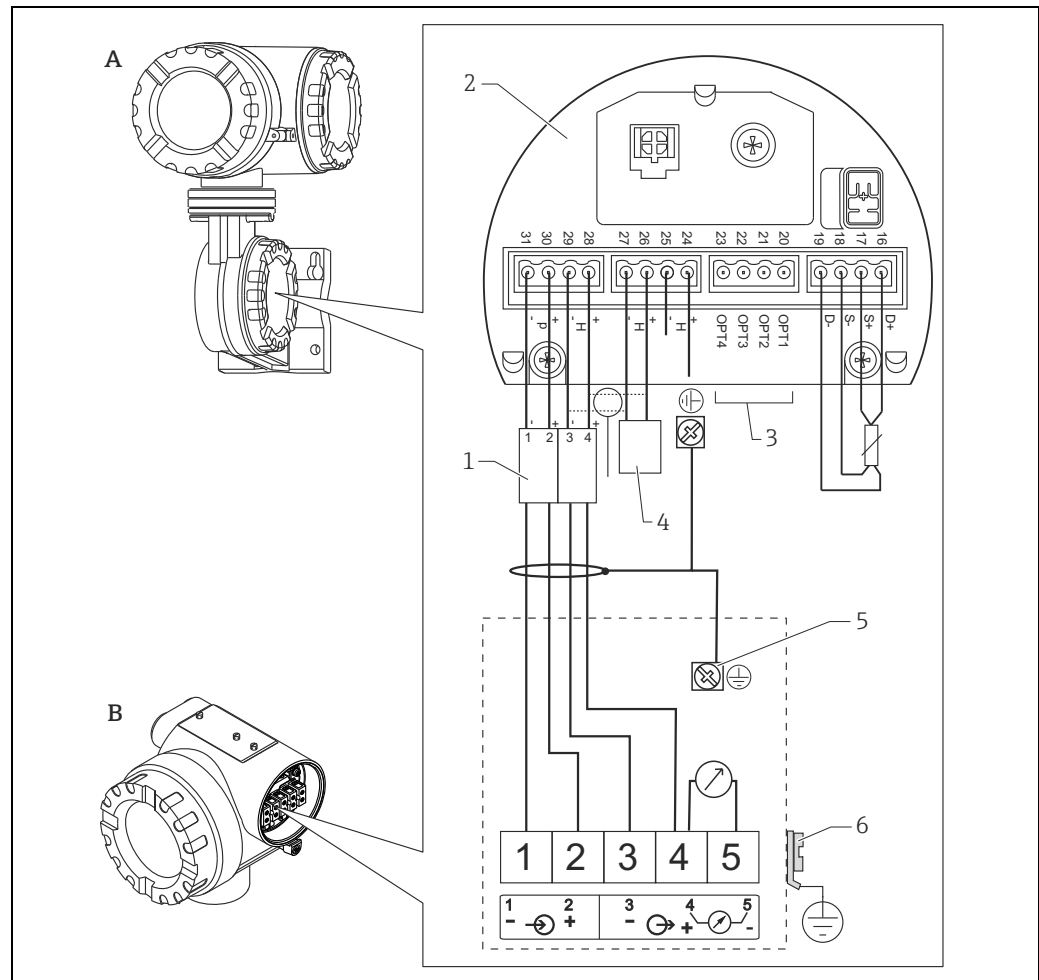

- A Tank Side Monitor NRF590
 B Micropilot S
 1 Only for Micropilot S
 2 Intrinsically safe terminal board
 3 Grounding single sided on Tank Side Monitor NRF590
 4 HART Sensor
 5 Shield ground
 6 PML (potential equalization line)

If there is no way to set a ground cable between NRF590 and Micropilot S it is possible to ground single side (grounding on side NRF590). In this case it's imperative to ground the shield (on Micropilot S side) via a ceramic capacitor with a maximum capacitance of 10 nF and a minimum insulating voltage of 1500 V.

The Micropilot S is - possibly in combination with other devices - connected to a tank side monitor in a hazardous area. In this case, it is recommended that you ground the cable screen centrally at the Tank

Side Monitor and connect all devices to the same potential matching line (PML). If, for functional reasons, a capacitive coupling is required between local earth and screen (multiple grounding), ceramic condensers with a dielectric strength of min. 1500 Veff must be used, whereby the total capacitance of 10 nF must not be exceeded. Notes on grounding interconnected intrinsically safe devices are provided by the FISCO model.

Spot RTD

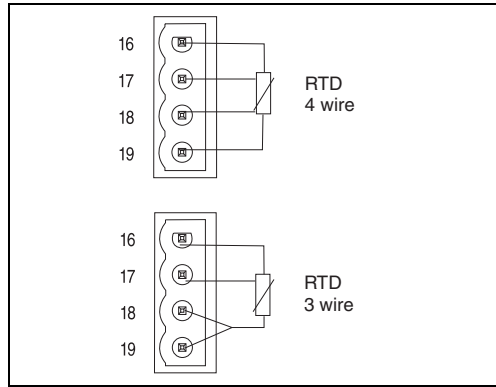

A spot RTD can be connected to the NRF590 if the option is installed. For 4-wire connection, the RTD must be connected to the 4 available terminals marked D+, S+, S- and D-. For 3-wire connection, the RTD should be connected to the same 4 terminals. The terminals D- and S- should be connected together directly at the NRF590 terminals.

Performance characteristics

Accuracy

HART sensors

Accuracy of all data from connected HART sensors depends on the type and installation of instruments. The use of the digital HART protocol prevents accuracy data degradation, as would be the case with analogue (4 to 20 mA) sensors.

Spot RTD input, analogue inputs, analogue outputs

See "Technical data of the IS inputs and outputs".

Resolution

Resolution of all measured data depends on sensor and communication settings. The following settings are recommended for inventory and custody transfer applications:

Data type	Units	Inventory control	Custody transfer
Level	millimeters	1 mm	1 or 0.1 mm
	meters	10 mm	1 or 0.1 mm
	feet	0.01 ft	0.01 ft
	inches	1" or 0.1"	0.01" or 0.001"
	ft-in-16	1/16"	1/16"
Temperature	°C	0.1 °C	0.1 °C
	°F	0.1 °F	0.1 °F

For purpose of consistency all internal calculations are performed in SI units.

Scan time

HART sensors

The data of connected HART sensors is constantly scanned and updated in the internal data base. The scanning sequence is based on the priorities of the measurements (level - prio 1, temperature - prio 2, pressure - prio 3,...). Typically, a value change on the HART multidrop loop is displayed after a 2 seconds delay (for priority 1 values).

Spot RTD input

RTD resistance is measured and recalculated at least every second.

Installation conditions

Wall mounting

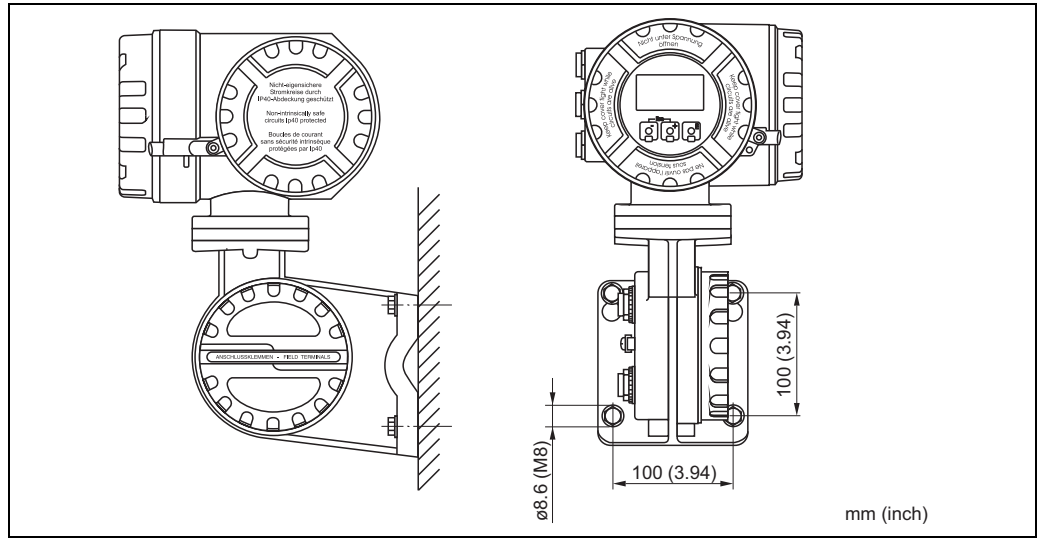

L00-NRF590-17-00-06-xx-001

Mounting on vertical rail

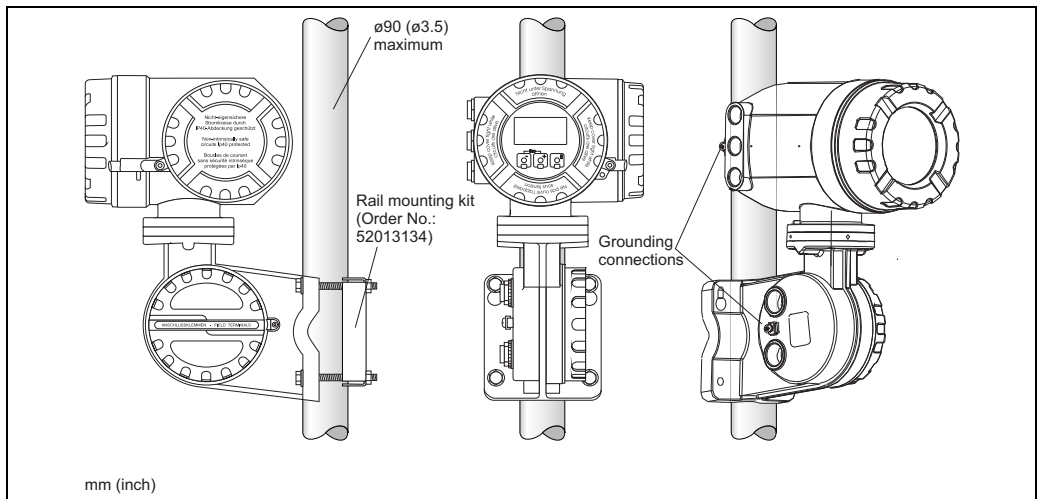

L00-NRF590-17-00-06-en-002

Mounting on horizontal rail

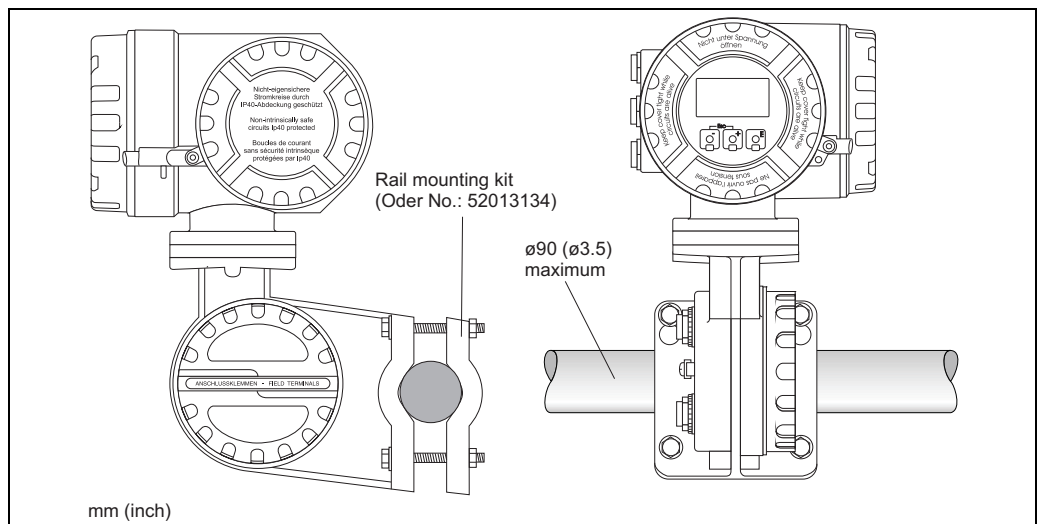

L00-NRF590-17-00-06-en-003

Ambient conditions

Ambient temperature	-40 °C to +60 °C (-40 °F to +140 °F)
Storage temperature	-55 °C to +85 °C (-67 °F to +185 °F)
Ingress protection	IP65, Nema 4X
Electromagnetic compatibility (EMC)	<ul style="list-style-type: none">■ Interference emission to EN 61326, Equipment class A■ Interference immunity to EN 61326 Use shielded signal lines for installation.
Overvoltage protection	Both interfaces of the NRF590 - the Ex ia and the Ex d side - are protected by internal 600 Vrms surge arresters which have been tested against 10 kA transient discharges.

Mechanical construction

Design, dimensions

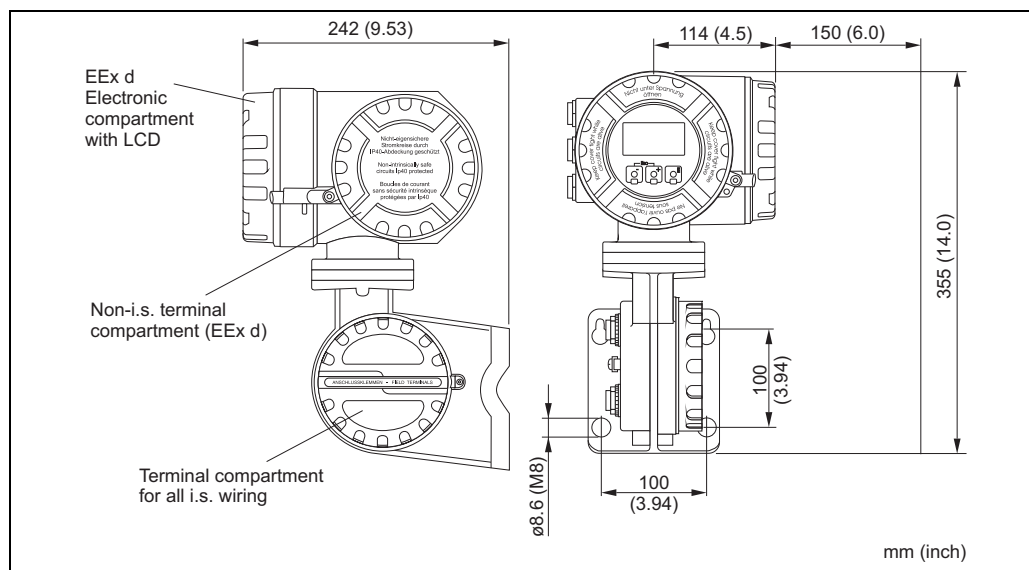

Material

- Remote field housing: powder coated die-cast aluminium
- Wall-mount housing: powder coated die-cast aluminium
- Window material: glass

Construction

The NRF590 housing has three separate compartments, one containing all electronics and two for electrical connections. The enclosure is die-cast aluminum with an polyester coating and IP65 (NEMA 4) rating.

The upper terminal compartment and electronics compartment are designated for non-i.s. connections and electronics and are rated EEx d. The lower terminal compartment is designated for i.s. wiring connections and wiring only.

Weight

approx. 8 kg

Cable entries

The non-i.s. terminal compartment has 3 cable entries. The threading in this terminal compartment enclosure is M20x1.5. All intrinsically designated wiring has to be terminated in the i.s. terminal compartment.

For the i.s. wiring, two M25x1.5 cable entries are available. The internal diameter of the cable entry is 16 mm.

For accommodating various types of cable glands or cable conduit (rigid or flexible), the following sizes of cable gland adapters are optionally available:

- M20x1.5
- G $\frac{1}{2}$
- $\frac{1}{2}$ " NPT
- $\frac{3}{4}$ " NPT (max. 2 cable entries)

All adapters are rated EEx d and can be used for either cable connection. When installing, properly seal all ports to prevent moisture or other contamination from entering the wiring compartments.

Human interface

Display and operating elements

Liquid crystal display (LCD)

Four lines with 20 characters each. Display contrast adjustable through key combination. The backlight of the display is activated during operation for user defined time (30 sec continuous backlight). The following display languages can be selected by the user:

- English
- German
- Japanese¹⁾
- Simplified Chinese²⁾
- Dutch
- Spanish
- French
- Italian

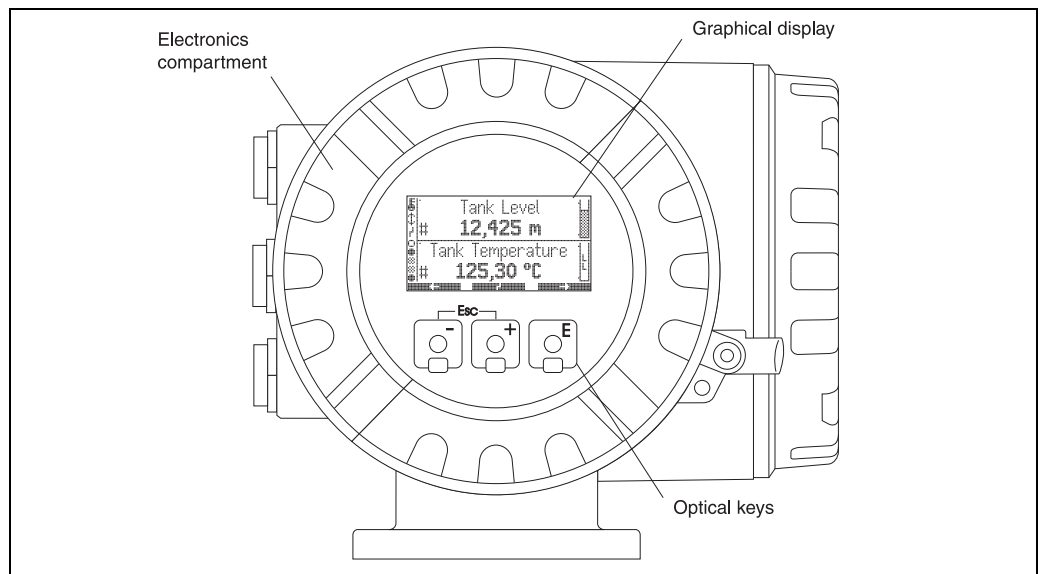

L00-NRF590-07-00-00-en-001

Optical keys

The optical keys allow the Tank Side Monitor to be operated without the housing being opened. From Software Version 02.xx.xx onwards they function as softkeys, i.e. their meaning varies depending on the current position within the operating menu. The meaning is indicated by softkey symbols in the bottom line of the display:

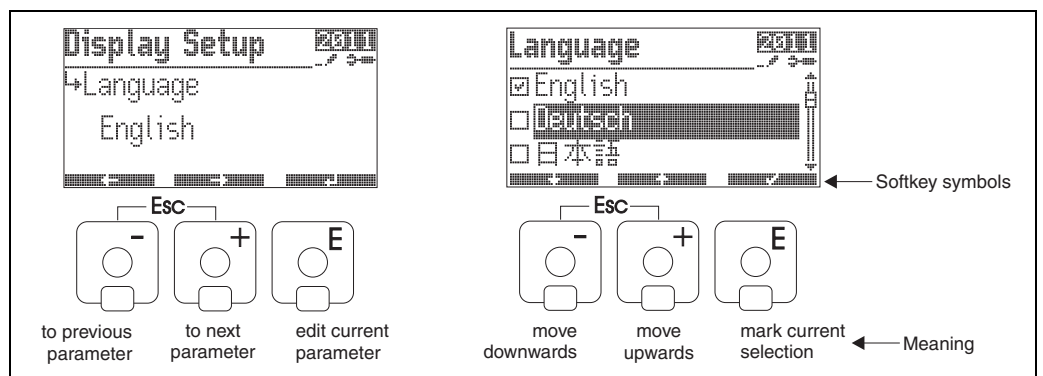

L00-NRF590-07-00-00-en-003

1) Japanese font: JIS X 208-1997 including Hiragana, Katakana and Kanji
 2) Chinese font: GB18030, CITS Committee approved

Format of decimal numbers

The number of decimal places displayed can be selected from three resolution presets (high, normal, low)

VAlue	resolution preset		
	low	normal	high
level units			
mm	xxxxx	xxxxx	xxxxx.x
cm	xxxx.x	xxxx.x	xxxx.x
m	xx.xxx	xx.xxx	xx.xxxx
in	xxxx.x	xxxx.x	xxxx.xx
ft	xxx.xxx	xxx.xxx	xxx.xxxx
ft-in-8	xx'xx"x/8	xx'xx"x/8	xx'xx"x/8
ft-in-16	xx'xx'xx/16	xx'xx'xx/16	xx'xx'xx/16
16ths	xxxxx	xxxxx	xxxxx.x
temperature units			
°C	xxx	xxx.x	xxx.xx
°F	xxx	xxx.x	xxx.xx
pressure units			
Pa	xxxxxxx	xxxxxxx	xxxxxxx
kPa	xxxx.x	xxxx.xx	xxxx.xxx
MPa	x.xxxx	x.xxxxx	x.xxxxxx
mbar	xxxxx	xxxxx	xxxxx.x
bar	xx.xxx	xx.xxx	xx.xxxx
psi	xxx	xxx.x	xxx.xx
inH ₂ O	xxxxx	xxxxx.x	xxxxx.x
density units			
kg/m ³	xxxx.x	xxxx.xx	xxxx.xx
g/ml	x.xxxx	x.xxxx	x.xxxxx
lb/ft ³	xx.xx	xx.xxx	xx.xxxx
°API	xxx.xx	xxx.xx	xxx.xxx
current units			
mA	xx.xxx	xx.xxx	xx.xxxx

Operating concept

The Tank Side Monitor is operated via a four-layer menu. The structure of the menu accounts for typical measuring tasks as well as for the individual instrument configuration and installation. In particular, the menu contains dynamic function groups which are only indicated if the respective option is installed or the respective instrument is connected. This structure ensures clarity and simple operation without restricting the scope of functionality.

The appearance and meaning of the LCD change according to the current position within the menu.

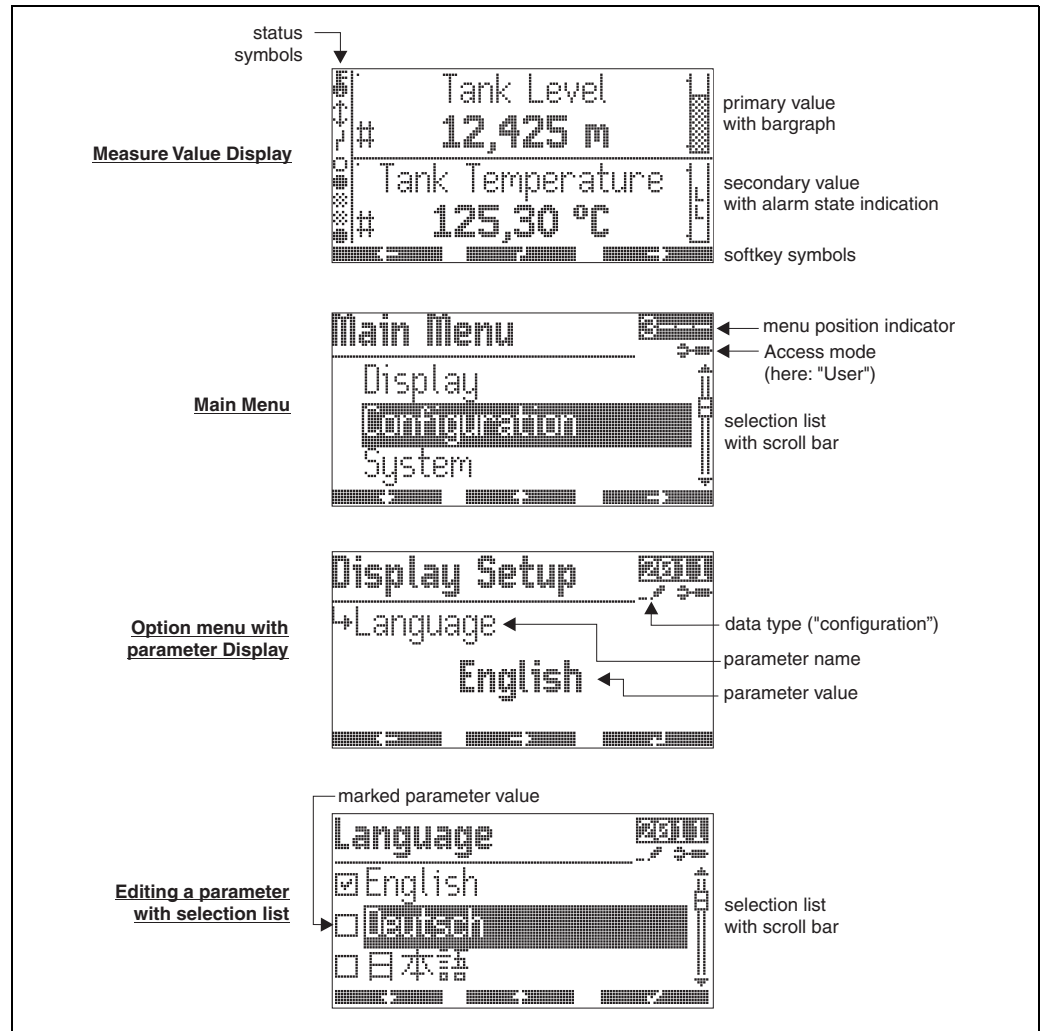

L00-NRF590-07-00-00-en-004

Remote operation

FieldCare is an Endress+Hauser asset management tool based on FDT technology. With FieldCare, you can configure all Endress+Hauser devices as well as devices from other manufacturers that support the FDT standard. Hardware and software requirements you can find on the internet: www.endress.com » select your country » search: FieldCare.

FieldCare supports the following functions

- Configuration of transmitter in online operation
- Loading and saving of instrument data (Upload/Download)
- Documentation of measuring point

Certificates and Approvals

CE mark The measuring system meets the legal requirements of the EC-guidelines.
Endress+Hauser confirms the instrument passing the required tests by attaching the CE-mark.

Ex approvals

FM
FM XP - Class I, Div 1 Groups A-D
Note the Installation Drawings ZD00084F/00/EN

CSA
FM XP - Class I, Div 1 Groups A-D
Note the Installation Drawings ZD00103F/00/EN

ATEX
ATEX II 2 (1) G Ex d [ia Ga] IIC T6 Gb
Note the Safety Instructions XA00160F/00/A3

Custody transfer approvals

- NMI type approval
- PTB type approval

External standards and guidelines

EN 60529

Protection class of housing (IP-code).

EN 61010

Safety regulations for electrical devices for measurement, control, regulation and laboratory use.

EN 61326

Emissions (equipment class B), compatibility (appendix A - industrial use).

API MPMS Ch. 3.1A

Standard Practice for Manual Gauging of Petroleum and Petroleum Products in Stationary Tanks.

API MPMS Ch. 3.1B

Standard Practice for Level Measurement of Liquid Hydrocarbons in Stationary Tanks by Automatic Tank Gauging.

API MPMS Ch. 3.3

Standard Practice for Level Measurement of liquid Hydrocarbons in Stationary Pressurized Storage Tanks by Automatic Tank Gauging.

API MPMS Ch. 3.6

Measurement of Liquid Hydrocarbons by Hybrid Tank Measurement Systems.

API MPMS Ch. 7.4

Static Temperature Determination Using Fixed Automatic Tank Thermometers.

ISO 4266 / Part 1

Petroleum and liquid petroleum products - Measurement of level and temperature in storage tanks by automatic methods - Part 1: Measurement of level in atmospheric tanks.

ISO 4266 / Part 3

Petroleum and liquid petroleum products - Measurement of level and temperature in storage tanks by automatic methods - Part 3: Measurement of level in pressurized storage tanks (non refrigerated).

ISO 4266 / Part 4

Petroleum and liquid petroleum products - Measurement of level and temperature in storage tanks by automatic methods - Part 4: Measurement of temperature in atmospheric tanks.

ISO 4266 / Part 6

Petroleum and liquid petroleum products - Measurement of level and temperature in storage tanks by automatic methods - Part 6: Measurement of temperature in pressurized tanks.

ISO 15169

Petroleum and liquid petroleum products - Determination of volume, density and mass of the contents of vertical cylindrical tanks by Hybrid Tank Measurement Systems.

OIML - R85

Organisation Internationale de Métrologie Légale - Automatic level gauges for measuring the level of liquid in fixed storage tanks.

Ordering information

Tank Side Monitor NRF590

This overview does not mark options which are mutually exclusive.

10	Approval	A	Non-hazardous areas
		B	NEPSI Ex d(ia) IIC T6
		6	ATEX II 2 (1) EEx d (ia) IIC T6
		U	CSA XP Cl. I, Div 1, Gr. A-D, zone 1, 2
		S	FM XP Cl. I, Div 1, Gr. A-D, zone 1, 2
		K	TIIS EEx d (ia) IIC T6
		Y	Special version, TSP-No. to be spec.
20	Field communication protocol Ex d/XP	E	ENRAF BPM, 4-20mA input, 4-20mA HART output
		G	GPE, -20mA output, 4-20mA HART output
		1	Whessoe WM550 (dual output), 4-20mA output, 4-20mA HART output
		3	Mark/Space, 4-20mA input, 4-20mA HART output
		4	Modbus EIA 485
		5	Modbus, 4-20mA input, 4-20mA HART output
		7	L&J, 4-20mA input, 4-20mA HART output
		8	Sakura V1, 4-20mA output, 4-20mA HART output, Relais output
		9	Special version, TSP-No. to be spec.
30	Power supply	A	18-55 V AC/DC
		B	55-264V AC
		Y	Special version, TSP-No. to be spec.
40	Spot RTD option	0	Not selected
		1	Intrinsically safe input
		9	Special version, TSP-No. to be spec.
50	Digital Module A	A	Not selected
		B	Input 90-140V AC
		C	Input 3-32V DC
		D	Input 180-264V AC
		E	Input 35-60V AC/DC
		G	Output 24-250V AC
		H	Output 3-60V DC
		J	Output 24-140V AC
		K	Output 4-200V DC
		R	Relay 0-100 VDC, 0-120VAC
		Y	Special version, TSP-No. to be spec.
60	Digital Module B	A	Not selected
		B	Input 90-140V AC
		C	Input 3-32V DC
		D	Input 180-264V AC
		E	Input 35-60V AC/DC
		G	Output 24-250V AC
		H	Output 3-60V DC
		J	Output 24-140V AC
		K	Output 4-200V DC
		R	Relay 0-100 VDC, 0-120VAC
		Y	Special version, TSP-No. to be spec.
70	Additional intrinsically safe module	2	Input 4-20mA + 2x input digital
		9	Special version, TSP-No. to be spec.

80																					Cable entry (Non-IS)		
																					F	2 x Ex d gland G1/2	
																					B	2 x Ex d gland M20 (EEx d > thread M20)	
																					C	2 x Ex d thread G1/2	
																					D	2 x Ex d thread NPT1/2	
																					E	2 x Ex d thread NPT3/4	
																					H	3 x Ex d gland M20 (EEx d > thread M20)	
																					K	3 x Ex d thread G1/2	
																					L	3 x Ex d thread NPT1/2	
																					G	3 x Ex d thread NPT3/4 (in preparation)	
																					Y	Special version, TSP-No. to be spec.	
90																					Entry - IS Compartment		
																					2	2x gland M25, 13-18mm	
																					3	2x thread G1/2	
																					4	2x thread NPT1/2	
																					5	2s thread NPT3/4	
																					9	Special version, TSP-No. to be spec.	
100																					Weight + Measure Approval		
																					N	Not selected	
																					A	NMi type approval	
																					G	PTB type approval	
																					Y	Special version, TSP-No. to be spec.	
110																					Additional Option		
																					0	Basic version	
																					9	Special version, TSP-No. to be spec.	
995																					Marking		
																					1	Tagging (TAG), see additional spec.	
NRF590 -																					Complete product designation		

Accessories

Discrete I/O modules

Standard mechanical diagram for all I/O modules

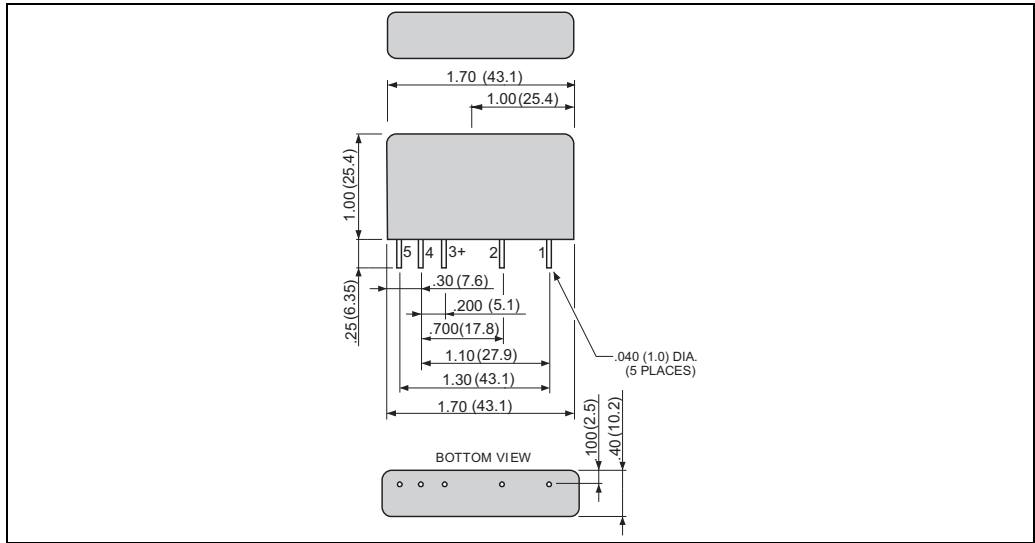

100-NRF590-00-00-08-en-001

Output modules

	AC voltage		DC voltage	
NRF590 order code ¹⁾ module A	NRF590 - ****J*****	NRF590 - ****G*****	NRF590 - ****I*****	NRF590 - ****K*****
NRF590 order code ¹⁾ module B	NRF590 - ****J*****	NRF590 - ****G*****	NRF590 - ****H*****	NRF590 - ****K*****
Order Code ²⁾	52012959	52012960	52012961	52012962
Colour of housing	black	black	red	red
Load voltage	24 to 140 V AC	24 to 250 V AC	3 to 60 V DC	4 to 200 V DC
Load current	30 to 500 mA eff. ³⁾		20 to 500 mA eff. ¹⁾	
Typ. power dissipation	1 W/A		1 to 1.5 W/A	
Transient protection	Meets IEEE472		Meets IEEE472	
Type of contact	SPST normally open Zero crossing turn-on		SPST normally open	
Optical isolation	yes		yes	
Isolation voltage	4000 V eff.		4000 V eff.	
Approvals	UL, CSA, CE, TÜV		UL, CSA, CE, TÜV	

- 1) This order code is valid if the module is preinstalled in the Tank Side Monitor as module A or module B
- 2) This order code is valid if the module is ordered as an accessory.
- 3) This upper limit of the load current is determined by the Tank Side Monitor.

Input modules

	AC voltage		DC voltage	
NRF590 order code ¹⁾ module A	NRF590 - ****B*****	NRF590 - ****D*****	NRF590 - ****C*****	NRF590 - ****E*****
NRF590 order code ¹⁾ module B	NRF590 - ****B*****	NRF590 - ****D*****	NRF590 - ****C*****	NRF590 - ****E*****
Order code ²⁾	52012955	52012956	52012957	52012958
Colour of housing	yellow	yellow	white	white
Input voltage	90 to 140 V AC	180 to 264 V AC ³⁾	3 to 32 V DC	35 to 60 V DC
Nominal input resistance	22 kΩ	60 kΩ	22 kΩ	60 kΩ
Max. pick-up voltage	90 V AC	180 V AC	3 V DC	35 V DC
Min. drop-out voltage	25 V AC	50 V AC	1 V DC	9 V DC
Input current @ max. voltage	8 mA rms		8 mA rms	
Typ. power dissipation	1 to 1.5 W/A		1 to 1.5 W/A	
Transient protection	Meets IEEE472		Meets IEEE472	
Optical isolation	yes		yes	
Isolation voltage	4000 V rms		4000 V rms	
Approvals	UL, CSA, CE, TÜV		UL, CSA, CE, TÜV	

- 1) This order code is valid if the module is preinstalled in the Tank Side Monitor as module A or module B.
- 2) This order code is valid if the module is ordered as an accessory.
- 3) This upper limit of the input voltage is determined by the Tank Side Monitor.

Relay output module

NRF590 order code ¹⁾ module A	NRF590 - ****R*****
NRF590 order code ¹⁾ module B	NRF590 - *****R*****
Order code ²⁾	52026945
Colour of housing	red
Load voltage	0 to 100 VDC / 0 to 120 VAC
Load current	0 to 500 mA ³⁾
Max. contact resistance	250 mΩ
Max. turn on/off time ⁴⁾	1 ms
Min. life expectancy	500000 cycles
Type of contact	SPST normally open; mechanical relay
Isolation voltage	1500 V _{eff}
Approvals	UL, CSA, CE, TÜV

1) This order code is valid if the module is preinstalled in the Tank Side Monitor as module A or module B.

2) This order code is valid if the module is ordered as an accessory.

3) For inductive loads, use diode suppression or RC network to improve contact life.

4) Including debounce

Rail mounting kit

For rail mounting the Tank Side Monitor to vertical or horizontal pipe.
Order-Number: 52013134

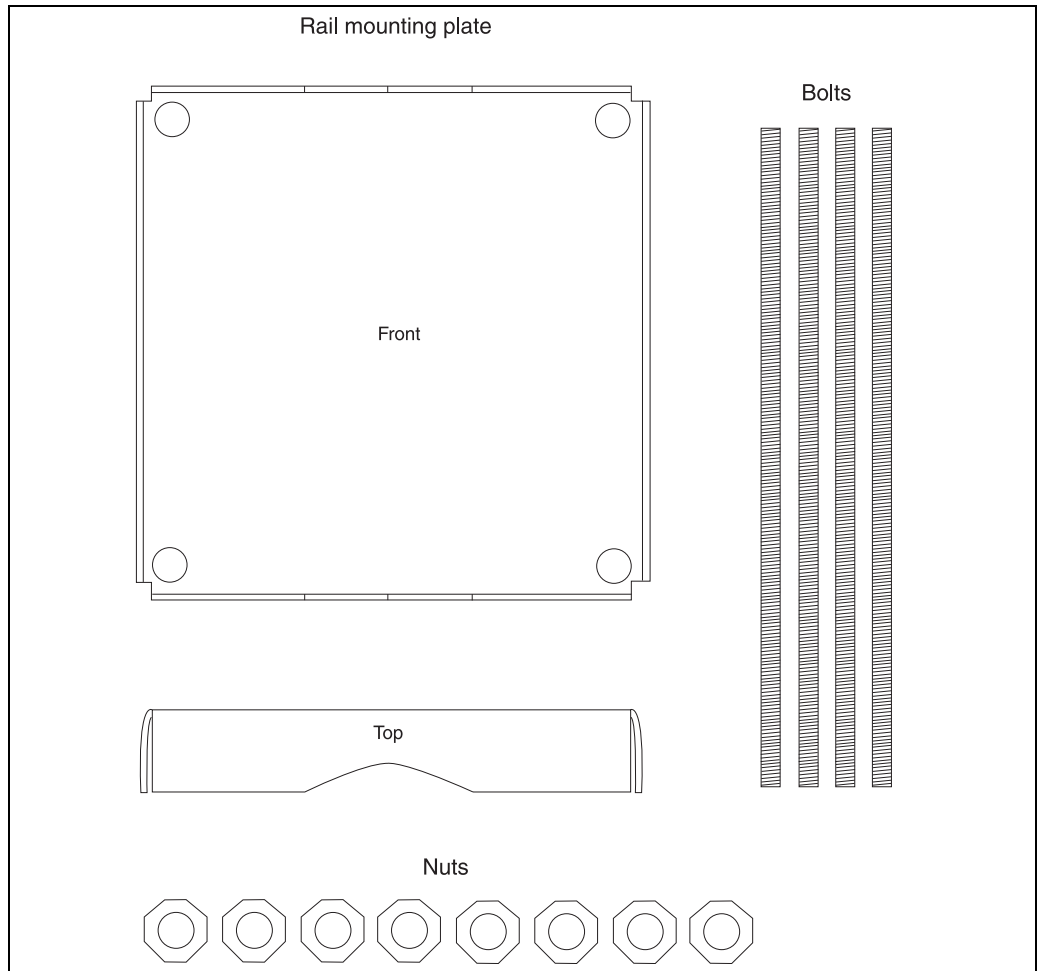

L00-NRF590-00-00-06-en-001

Supplementary Documentation

Technical Information

TI00419G/00/EN

Technical Information Tankvision NXA820, NXA821, NXA822

TI00042N/08/EN

Technical Information Prothermo NMT539

TI00344F/00/EN

Technical Information Micropilot S FMR530

TI01122F/00/EN

Technical Information Micropilot S FMR532

TI01123F/00/EN

Technical Information Micropilot S FMR533

TI00412F/00/EN

Technical Information Micropilot S FMR540

TI00345F/00/EN

Technical Information Micropilot M FMR230, FMR231, FMR240, FMR244, FMR245

Operating Instructions

BA00256F/00/EN

Operating Instructions Tank Side Monitor NRF590.

This document describes installation and commissioning of the Tank Side Monitor.

Only those functions of the operating menu are included, which are relevant for a usual application.

BA00257F/00/EN

Tank Side Monitor - Description of Instrument Functions.

This document contains a detailed description of all the functions of the Tank Side Monitor.

Safety Instructions

XA00160F/00/A3

Tank Side Monitor NRF590 - ATEX II 2 (1) G Ex d [ia Ga] IIC T6 Gb

Control Drawings

ZD00084F/00/EN

Tank Side Monitor NRF590 - FM XP - Class I, Div. 1, Groups A-D

ZD00103F/00/EN

Tank Side Monitor NRF590 - CSA XP - Class I, Div. 1, Groups A-D





www.addresses.endress.com
