

Operating Instructions

Proline Promag H 100

HART

Electromagnetic flowmeter

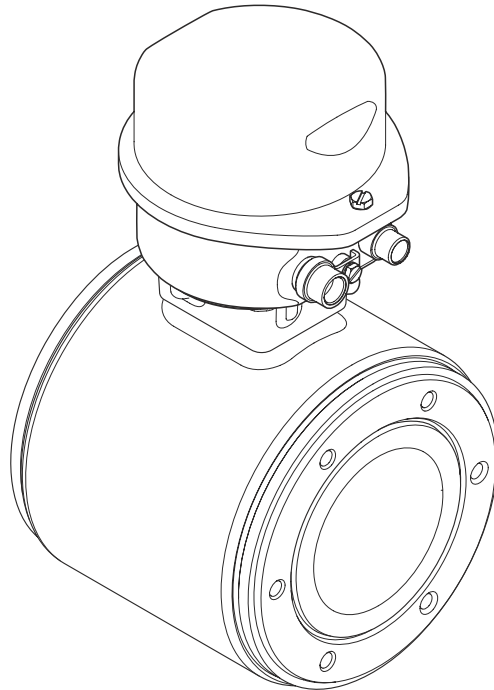

- Make sure the document is stored in a safe place such that it is always available when working on or with the device.
- To avoid danger to individuals or the facility, read the "Basic safety instructions" section carefully, as well as all other safety instructions in the document that are specific to working procedures.
- The manufacturer reserves the right to modify technical data without prior notice. Your Endress+Hauser Sales Center will supply you with current information and updates to these Instructions.

Table of contents

1	Document information	5	6.3	Post-installation check	25
1.1	Document function	5	7	Electrical connection	27
1.2	Symbols used	5	7.1	Connection conditions	27
1.2.1	Safety symbols	5	7.1.1	Required tools	27
1.2.2	Electrical symbols	5	7.1.2	Requirements for connecting cable	27
1.2.3	Tool symbols	6	7.1.3	Terminal assignment	28
1.2.4	Symbols for certain types of information	6	7.1.4	Pin assignment, device plug	29
1.2.5	Symbols in graphics	6	7.1.5	Preparing the measuring device	29
1.3	Documentation	7	7.2	Connecting the measuring device	29
1.3.1	Standard documentation	7	7.2.1	Connecting the transmitter	29
1.3.2	Supplementary device-dependent documentation	7	7.2.2	Ensuring potential equalization	31
1.4	Registered trademarks	7	7.3	Special connection instructions	33
2	Basic safety instructions	8	7.3.1	Connection examples	33
2.1	Requirements for the personnel	8	7.4	Ensuring the degree of protection	33
2.2	Designated use	8	7.5	Post-connection check	33
2.3	Workplace safety	9	8	Operation options	34
2.4	Operational safety	9	8.1	Overview of operation options	34
2.5	Product safety	9	8.2	Structure and function of the operating menu	35
2.6	IT security	9	8.2.1	Structure of the operating menu	35
3	Product description	11	8.2.2	Operating philosophy	36
3.1	Product design	11	8.3	Access to the operating menu via the Web browser	36
3.1.1	Device version with HART communication type	11	8.3.1	Function range	36
4	Incoming acceptance and product identification	12	8.3.2	Prerequisites	37
4.1	Incoming acceptance	12	8.3.3	Establishing a connection	37
4.2	Product identification	12	8.3.4	Logging on	38
4.2.1	Transmitter nameplate	13	8.3.5	User interface	38
4.2.2	Sensor nameplate	14	8.3.6	Disabling the Web server	39
4.2.3	Symbols on measuring device	15	8.3.7	Logging out	40
5	Storage and transport	16	8.4	Access to the operating menu via the operating tool	40
5.1	Storage conditions	16	8.4.1	Connecting the operating tool	40
5.2	Transporting the product	16	8.4.2	Field Xpert SFX350, SFX370	41
5.3	Packaging disposal	17	8.4.3	FieldCare	41
6	Mounting	17	8.4.4	AMS Device Manager	43
6.1	Installation conditions	17	8.4.5	SIMATIC PDM	43
6.1.1	Mounting position	17	8.4.6	Field Communicator 475	44
6.1.2	Requirements from environment and process	19	9	System integration	45
6.2	Mounting the measuring device	21	9.1	Overview of device description files	45
6.2.1	Required tools	21	9.1.1	Current version data for the device	45
6.2.2	Preparing the measuring device	21	9.1.2	Operating tools	45
6.2.3	Mounting the sensor	22	9.2	Measured variables via HART protocol	45
6.2.4	Turning the display module	24	9.3	Other settings	47
			9.3.1	Burst mode functionality in accordance with HART 7 Specification	47
			10	Commissioning	49
			10.1	Function check	49

10.2	Configuring the measuring device	49	13	Maintenance	87
10.2.1	Defining the tag name	49	13.1	Maintenance tasks	87
10.2.2	Configuring the current output	50	13.1.1	Exterior cleaning	87
10.2.3	Configuring the pulse/frequency/ switch output	51	13.1.2	Interior cleaning	87
10.2.4	Configuring the local display	55	13.1.3	Replacing seals	87
10.2.5	Configuring the HART input	56	13.2	Measuring and test equipment	87
10.2.6	Configuring the output conditioning	57	13.3	Endress+Hauser services	87
10.2.7	Configuring the low flow cut off	58	14	Repair	88
10.2.8	Configuring empty pipe detection	60	14.1	General notes	88
10.3	Advanced settings	61	14.2	Spare parts	88
10.3.1	Setting the system units	61	14.3	Endress+Hauser services	88
10.3.2	Carrying out a sensor adjustment	62	14.4	Return	88
10.3.3	Configuring the totalizer	63	14.5	Disposal	88
10.3.4	Carrying out additional display configurations	64	14.5.1	Removing the measuring device	88
10.3.5	Performing electrode cleaning	66	14.5.2	Disposing of the measuring device	89
10.4	Simulation	67	15	Accessories	90
10.5	Protecting settings from unauthorized access	68	15.1	Device-specific accessories	90
10.5.1	Write protection via access code	69	15.1.1	For the transmitter	90
10.5.2	Write protection via write protection switch	69	15.1.2	For the sensor	90
11	Operation	71	15.2	Communication-specific accessories	91
11.1	Reading device locking status	71	15.3	Service-specific accessories	91
11.2	Reading measured values	71	15.4	System components	92
11.2.1	Process variables	71	16	Technical data	93
11.2.2	Totalizer	72	16.1	Application	93
11.2.3	Output values	72	16.2	Function and system design	93
11.3	Adapting the measuring device to the process conditions	73	16.3	Input	93
11.4	Performing a totalizer reset	73	16.4	Output	95
12	Diagnostics and troubleshooting	75	16.5	Power supply	97
12.1	General troubleshooting	75	16.6	Performance characteristics	98
12.2	Diagnostic information via light emitting diodes	76	16.7	Installation	100
12.2.1	Transmitter	76	16.8	Environment	100
12.3	Diagnostic information in FieldCare	76	16.9	Process	101
12.3.1	Diagnostic options	76	16.10	Mechanical construction	102
12.3.2	Calling up remedy information	77	16.11	Operability	105
12.4	Adapting the diagnostic information	78	16.12	Certificates and approvals	107
12.4.1	Adapting the diagnostic behavior	78	16.13	Application packages	108
12.4.2	Adapting the status signal	78	16.14	Accessories	109
12.5	Overview of diagnostic information	78	16.15	Supplementary documentation	109
12.6	Pending diagnostic events	81	17	Appendix	111
12.7	Diagnostic list	82	17.1	Overview of the operating menu	111
12.8	Event logbook	82	17.1.1	Main menu	111
12.8.1	Event history	82	17.1.2	"Operation" menu	111
12.8.2	Filtering the event logbook	83	17.1.3	"Setup" menu	112
12.8.3	Overview of information events	83	17.1.4	"Diagnostics" menu	117
12.9	Resetting the measuring device	84	17.1.5	"Expert" menu	119
12.10	Device information	84	Index	133	
12.11	Firmware history	86			





1 Document information

1.1 Document function







These Operating Instructions contain all the information that is required in various phases of the life cycle of the device: from product identification, incoming acceptance and storage, to mounting, connection, operation and commissioning through to troubleshooting, maintenance and disposal.

1.2 Symbols used



1.2.1 Safety symbols

Symbol	Meaning
	DANGER! This symbol alerts you to a dangerous situation. Failure to avoid this situation will result in serious or fatal injury.
	WARNING! This symbol alerts you to a dangerous situation. Failure to avoid this situation can result in serious or fatal injury.
	CAUTION! This symbol alerts you to a dangerous situation. Failure to avoid this situation can result in minor or medium injury.
	NOTE! This symbol contains information on procedures and other facts which do not result in personal injury.











1.2.2 Electrical symbols

Symbol	Meaning
	Direct current A terminal to which DC voltage is applied or through which direct current flows.
	Alternating current A terminal to which alternating voltage is applied or through which alternating current flows.
	Direct current and alternating current <ul style="list-style-type: none"> ▪ A terminal to which alternating voltage or DC voltage is applied. ▪ A terminal through which alternating current or direct current flows.
	Ground connection A grounded terminal which, as far as the operator is concerned, is grounded via a grounding system.
	Protective ground connection A terminal which must be connected to ground prior to establishing any other connections.
	Equipotential connection A connection that has to be connected to the plant grounding system: This may be a potential equalization line or a star grounding system depending on national or company codes of practice.





1.2.3 Tool symbols

Symbol	Meaning
	Allen key
	Open-ended wrench



1.2.4 Symbols for certain types of information

Symbol	Meaning
	Permitted Indicates procedures, processes or actions that are permitted.
	Preferred Indicates procedures, processes or actions that are preferred.
	Forbidden Indicates procedures, processes or actions that are forbidden.
	Tip Indicates additional information.
	Reference to documentation Refers to the corresponding device documentation.
	Reference to page Refers to the corresponding page number.
	Reference to graphic Refers to the corresponding graphic number and page number.
	Series of steps
	Result of a sequence of actions
	Help in the event of a problem
	Visual inspection

1.2.5 Symbols in graphics

Symbol	Meaning
1, 2, 3, ...	Item numbers
	Series of steps
A, B, C, ...	Views
A-A, B-B, C-C, ...	Sections
	Flow direction
	Hazardous area Indicates a hazardous area.
	Safe area (non-hazardous area) Indicates the non-hazardous area.

1.3 Documentation

-  For an overview of the scope of the associated Technical Documentation, refer to the following:
- The CD-ROM provided for the device (depending on the device version, the CD-ROM might not be part of the delivery!)
 - The *W@M Device Viewer* : Enter the serial number from the nameplate (www.endress.com/deviceviewer)
 - The *Endress+Hauser Operations App*: Enter the serial number from the nameplate or scan the 2-D matrix code (QR code) on the nameplate.
-  For a detailed list of the individual documents along with the documentation code (→  109)

1.3.1 Standard documentation

Document type	Purpose and content of the document
Technical Information	Planning aid for your device The document contains all the technical data on the device and provides an overview of the accessories and other products that can be ordered for the device.
Brief Operating Instructions	Guide that takes you quickly to the 1st measured value The Brief Operating Instructions contain all the essential information from incoming acceptance to initial commissioning.

1.3.2 Supplementary device-dependent documentation

Additional documents are supplied depending on the device version ordered: Always comply strictly with the instructions in the supplementary documentation. The supplementary documentation is an integral part of the device documentation.

1.4 Registered trademarks

HART®

Registered trademark of the HART Communication Foundation, Austin, USA

Microsoft®

Registered trademark of the Microsoft Corporation, Redmond, Washington, USA

Applicator®, FieldCare®, Field Xpert™, HistoROM®, Heartbeat Technology™

Registered or registration-pending trademarks of the Endress+Hauser Group

2 Basic safety instructions

2.1 Requirements for the personnel

The personnel for installation, commissioning, diagnostics and maintenance must fulfill the following requirements:

- ▶ Trained, qualified specialists must have a relevant qualification for this specific function and task
- ▶ Are authorized by the plant owner/operator
- ▶ Are familiar with federal/national regulations
- ▶ Before beginning work, the specialist staff must have read and understood the instructions in the Operating Instructions and supplementary documentation as well as in the certificates (depending on the application)
- ▶ Following instructions and basic conditions

The operating personnel must fulfill the following requirements:

- ▶ Being instructed and authorized according to the requirements of the task by the facility's owner-operator
- ▶ Following the instructions in these Operating Instructions

2.2 Designated use

Application and media

Depending on the version ordered, the measuring device can also measure potentially explosive, flammable, poisonous and oxidizing media.

Measuring devices for use in hazardous areas, in hygienic applications or in applications where there is an increased risk due to process pressure, are labeled accordingly on the nameplate.

To ensure that the measuring device remains in proper condition for the operation time:

- ▶ Only use the measuring device in full compliance with the data on the nameplate and the general conditions listed in the Operating Instructions and supplementary documentation.
- ▶ Based on the nameplate, check whether the ordered device is permitted for the intended use in the hazardous area (e.g. explosion protection, pressure vessel safety).
- ▶ Use the measuring device only for media against which the process-wetted materials are adequately resistant.
- ▶ If the measuring device is not operated at atmospheric temperature, compliance with the relevant basic conditions specified in the associated device documentation is absolutely essential: "Documentation" section (→  7).

Incorrect use

Non-designated use can compromise safety. The manufacturer is not liable for damage caused by improper or non-designated use.

WARNING

Danger of breakage of the sensor due to corrosive or abrasive fluids!

- ▶ Verify the compatibility of the process fluid with the sensor material.
- ▶ Ensure the resistance of all fluid-wetted materials in the process.
- ▶ Observe the specified pressure and temperature range.

Verification for borderline cases:

- ▶ For special fluids and fluids for cleaning, Endress+Hauser is glad to provide assistance in verifying the corrosion resistance of fluid-wetted materials, but does not accept any warranty or liability as minute changes in the temperature, concentration or level of contamination in the process can alter the corrosion resistance properties.

Residual risks

The external surface temperature of the housing can increase by max. 10 K due to the power consumption of the electronic components. Hot process fluids passing through the measuring device will further increase the surface temperature of the housing. The surface of the sensor, in particular, can reach temperatures which are close to the fluid temperature.

Possible burn hazard due to fluid temperatures!

- ▶ For elevated fluid temperature, ensure protection against contact to prevent burns.

2.3 Workplace safety

For work on and with the device:

- ▶ Wear the required personal protective equipment according to federal/national regulations.

For welding work on the piping:

- ▶ Do not ground the welding unit via the measuring device.

If working on and with the device with wet hands:

- ▶ It is recommended to wear gloves on account of the higher risk of electric shock.

2.4 Operational safety

Risk of injury.

- ▶ Operate the device in proper technical condition and fail-safe condition only.
- ▶ The operator is responsible for interference-free operation of the device.

Conversions to the device

Unauthorized modifications to the device are not permitted and can lead to unforeseeable dangers.

- ▶ If, despite this, modifications are required, consult with Endress+Hauser.

Repair

To ensure continued operational safety and reliability,

- ▶ Carry out repairs on the device only if they are expressly permitted.
- ▶ Observe federal/national regulations pertaining to repair of an electrical device.
- ▶ Use original spare parts and accessories from Endress+Hauser only.

2.5 Product safety

This measuring device is designed in accordance with good engineering practice to meet state-of-the-art safety requirements, has been tested, and left the factory in a condition in which it is safe to operate.

It meets general safety standards and legal requirements. It also complies with the EC directives listed in the device-specific EC Declaration of Conformity. Endress+Hauser confirms this by affixing the CE mark to the device.

2.6 IT security

We only provide a warranty if the device is installed and used as described in the Operating Instructions. The device is equipped with security mechanisms to protect it against any inadvertent changes to the device settings.

IT security measures in line with operators' security standards and designed to provide additional protection for the device and device data transfer must be implemented by the operators themselves.

3 Product description

3.1 Product design

3.1.1 Device version with HART communication type

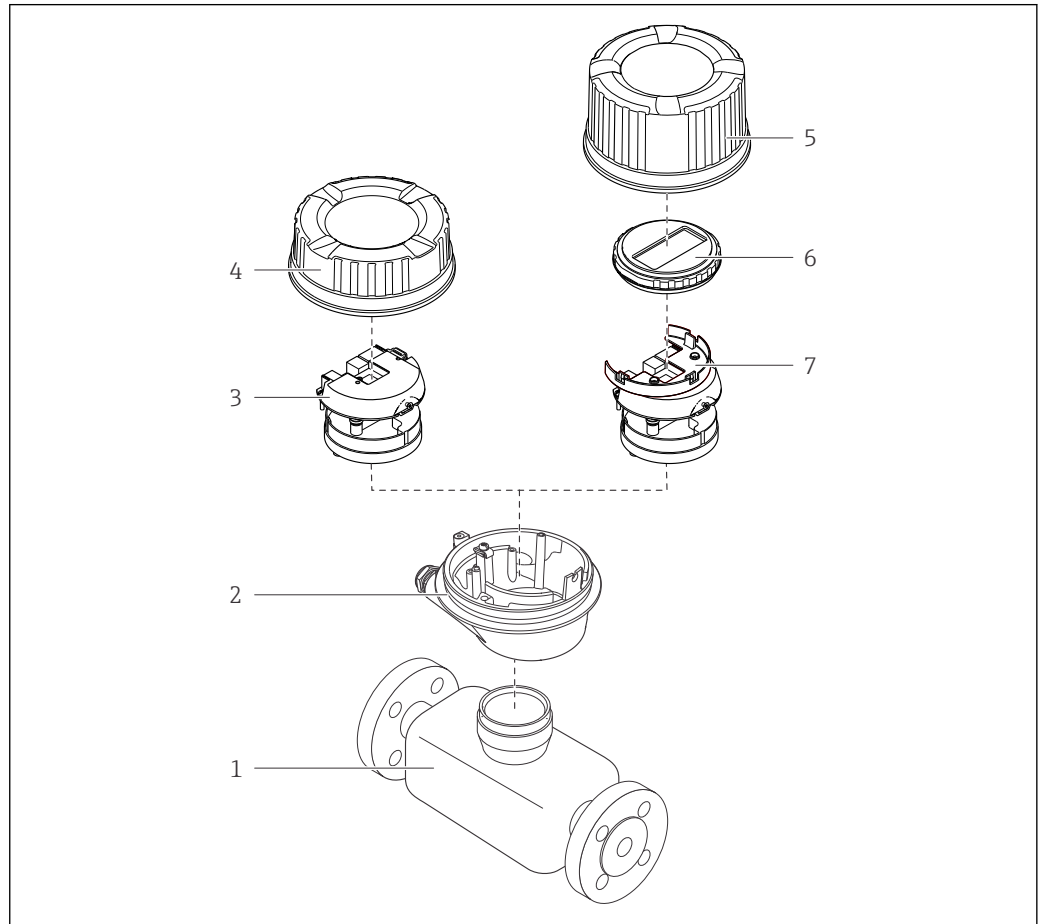





A0023153

1 Important components of a measuring device

- 1 Sensor
- 2 Transmitter housing
- 3 Main electronics module
- 4 Transmitter housing cover
- 5 Transmitter housing cover (version for optional onsite display)
- 6 Onsite display (optional)
- 7 Main electronics module (with bracket for optional onsite display)



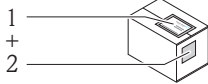
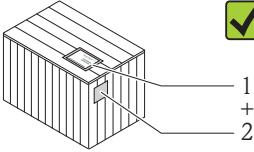

4 Incoming acceptance and product identification

4.1 Incoming acceptance

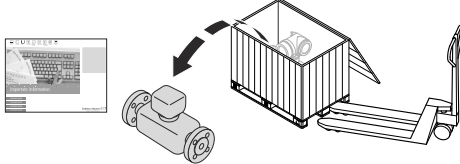



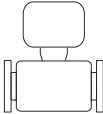
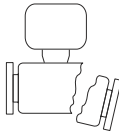



Are the order codes on the delivery note (1) and the product sticker (2) identical?



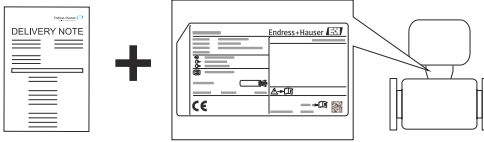



Are the goods undamaged?

Do the nameplate data match the ordering information on the delivery note?

Is the CD-ROM with the Technical Documentation (depends on device version) and documents present?



-  If one of the conditions is not satisfied, contact your Endress+Hauser Sales Center.
- Depending on the device version, the CD-ROM might not be part of the delivery! In such cases, the technical documentation is available via the Internet or via the *Endress+Hauser Operations App*, see the "Product identification" section (→  13).

4.2 Product identification

The following options are available for identification of the measuring device:

- Nameplate specifications
- Order code with breakdown of the device features on the delivery note
- Enter serial numbers from nameplates in *W@M Device Viewer* (www.endress.com/deviceviewer): All information about the measuring device is displayed.
- Enter the serial number from the nameplates into the *Endress+Hauser Operations App* or scan the 2-D matrix code (QR code) on the nameplate with the *Endress+Hauser Operations App*: all the information for the measuring device is displayed.

For an overview of the scope of the associated Technical Documentation, refer to the following:

- The chapters "Additional standard documentation on the device" (→  7) and "Supplementary device-dependent documentation" (→  7)
- The *W@M Device Viewer*: Enter the serial number from the nameplate (www.endress.com/deviceviewer)
- The *Endress+Hauser Operations App*: Enter the serial number from the nameplate or scan the 2-D matrix code (QR code) on the nameplate.

4.2.1 Transmitter nameplate

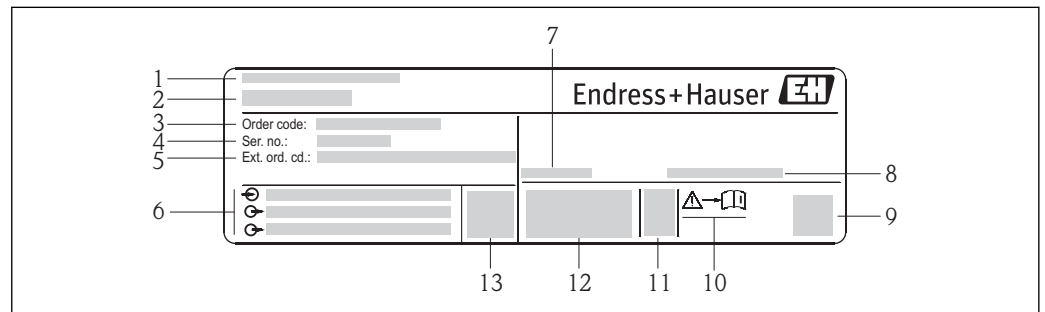

A0017520

 2 Example of a transmitter nameplate

- 1 Manufacturing location
- 2 Name of the transmitter
- 3 Order code
- 4 Serial number
- 5 Extended order code
- 6 Electrical connection data, e.g. available inputs and outputs, supply voltage
- 7 Permitted ambient temperature range (T_a)
- 8 Degree of protection
- 9 2-D matrix code
- 10 Document number of safety-related supplementary documentation
- 11 Manufacturing date: year-month
- 12 CE mark, C-Tick
- 13 Firmware version (FW)

4.2.2 Sensor nameplate

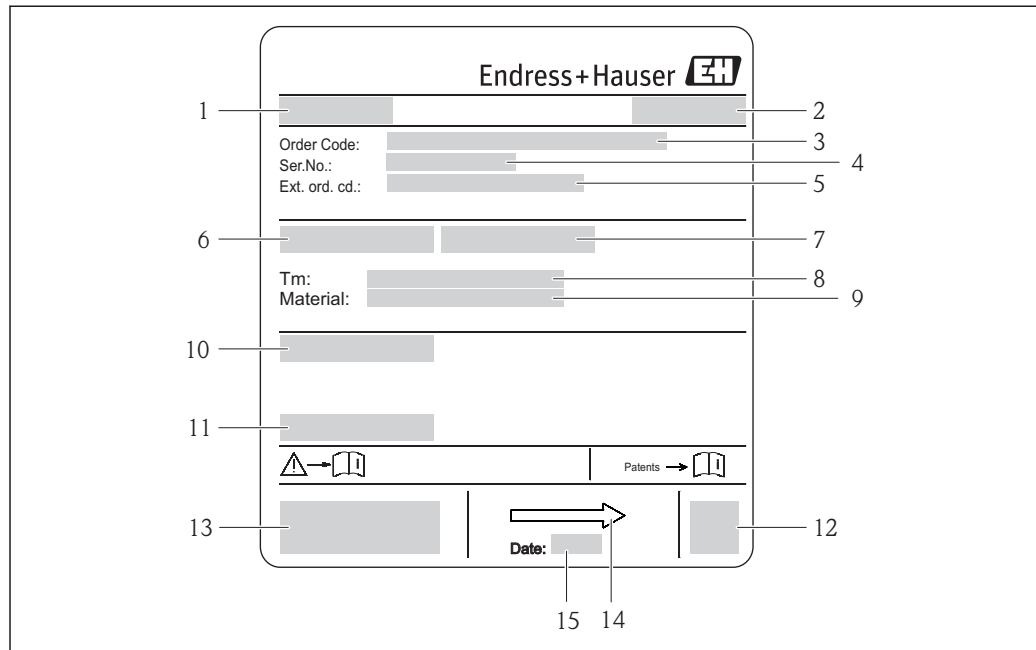

A0017186

 3 Example of sensor nameplate

- 1 Name of the sensor
- 2 Manufacturing location
- 3 Order code
- 4 Serial number (Ser. no.)
- 5 Extended order code (Ext. ord. cd.)
- 6 Nominal diameter of sensor
- 7 Test pressure of the sensor
- 8 Medium temperature range
- 9 Material of lining and electrodes
- 10 Degree of protection: e.g. IP, NEMA
- 11 Permitted ambient temperature (T_a)
- 12 2-D matrix code
- 13 CE mark, C-Tick
- 14 Flow direction
- 15 Manufacturing date: year-month





Order code

The measuring device is reordered using the order code.

Extended order code

- The device type (product root) and basic specifications (mandatory features) are always listed.
- Of the optional specifications (optional features), only the safety and approval-related specifications are listed (e.g. LA). If other optional specifications are also ordered, these are indicated collectively using the # placeholder symbol (e.g. #LA#).
- If the ordered optional specifications do not include any safety and approval-related specifications, they are indicated by the + placeholder symbol (e.g. XXXXXX-ABCDE +).

4.2.3 Symbols on measuring device

Symbol	Meaning
	WARNING! This symbol alerts you to a dangerous situation. Failure to avoid this situation can result in serious or fatal injury.
 A0011194	Reference to documentation Refers to the corresponding device documentation.
 A0011199	Protective ground connection A terminal which must be connected to ground prior to establishing any other connections.

5 Storage and transport

5.1 Storage conditions

Observe the following notes for storage:

- Store in the original packaging to ensure protection from shock.
- Do not remove protective covers or protective caps installed on process connections. They prevent mechanical damage to the sealing surfaces and contamination in the measuring tube.
- Protect from direct sunlight to avoid unacceptably high surface temperatures.
- Select a storage location where moisture cannot collect in the measuring device as fungus and bacteria infestation can damage the lining.
- Store in a dry and dust-free place.
- Do not store outdoors.
- Storage temperature(→ 📄 100)

5.2 Transporting the product

⚠ WARNING

Center of gravity of the measuring device is higher than the suspension points of the webbing slings.

Risk of injury if the measuring device slips.

- ▶ Secure the measuring device from rotating or slipping.
- ▶ Observe the weight specified on the packaging (stick-on label).
- ▶ Observe the transport instructions on the stick-on label on the electronics compartment cover.

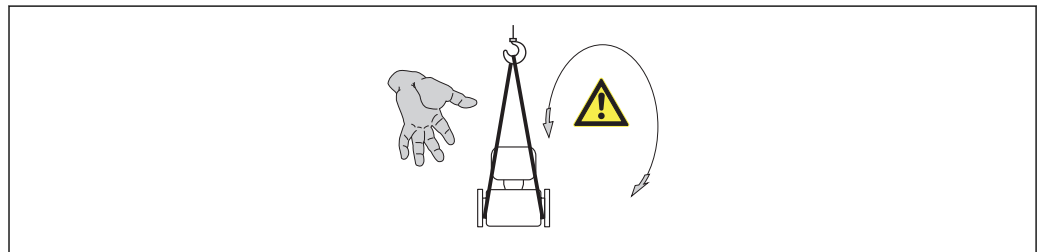

A0015606

- i** ▪ Transport the measuring device to the measuring point in the original packaging.
- Lifting gear
 - Webbing slings: Do not use chains, as they could damage the housing.
 - For wood crates, the floor structure enables these to be loaded lengthwise or broadside using a forklift.
- Use the webbing slings to lift the measuring device at the process connections; do not lift at the transmitter housing.
- Do not remove protective covers or protective caps installed on process connections. They prevent mechanical damage to the sealing surfaces and contamination in the measuring tube.

5.3 Packaging disposal

All packaging materials are environmentally friendly and 100% recyclable:

- Measuring device secondary packaging: polymer stretch film that conforms to EC Directive 2002/95/EC (RoHS).
- Packaging:
 - Wood crate, treated in accordance with ISPM 15 standard, which is confirmed by the affixed IPPC logo.
 - or
 - Carton in accordance with European Packaging Directive 94/62EC; recyclability is confirmed by the affixed RESY symbol.
- Seaworthy packaging (optional): Wood crate, treated in accordance with ISPM 15 standard, which is confirmed by the affixed IPPC logo.
- Carrying and mounting hardware:
 - Disposable plastic pallet
 - Plastic straps
 - Plastic adhesive strips
- Dunnage: Paper cushion

6 Mounting

6.1 Installation conditions

6.1.1 Mounting position

Mounting location

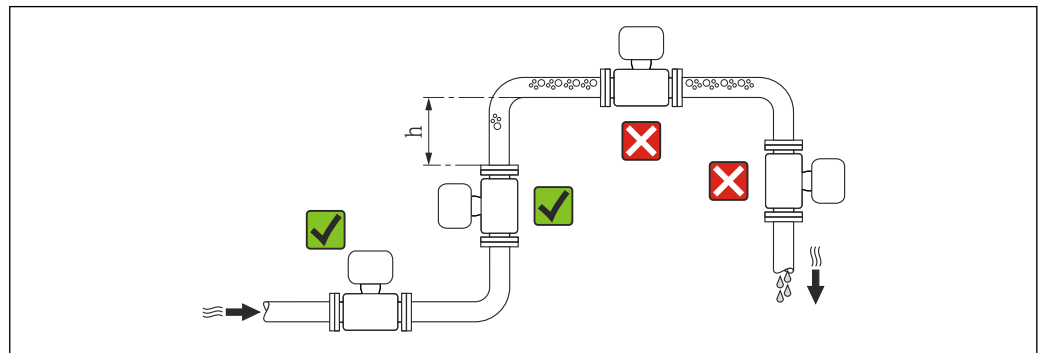

Preferably install the sensor in an ascending pipe, and ensure a sufficient distance to the next pipe elbow: $h \geq 2 \times DN$

To prevent measuring errors arising from accumulation of gas bubbles in the measuring tube, avoid the following mounting locations in the pipe:

- Highest point of a pipeline.
- Directly upstream of a free pipe outlet in a down pipe.

Installation in down pipes

Install a siphon with a vent valve downstream of the sensor in down pipes whose length $h \geq 5 \text{ m}$ (16.4 ft). This precaution is to avoid low pressure and the consequent risk of damage to the measuring tube. This measure also prevents the system losing prime.

 For information on the liner's resistance to partial vacuum (\rightarrow  101)

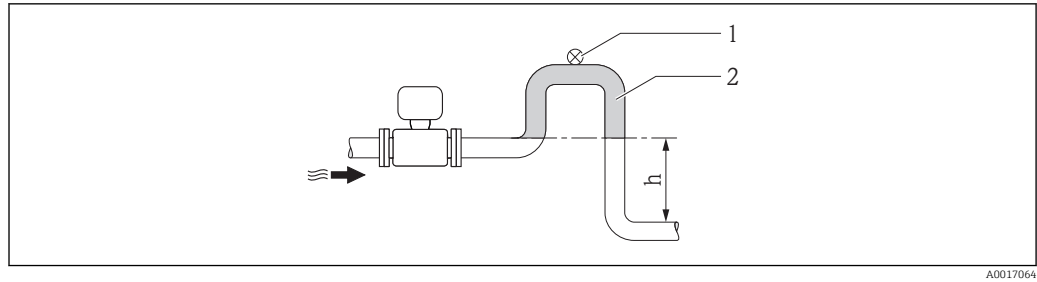

A0017064

4 Installation in a down pipe

- 1 Vent valve
- 2 Pipe siphon
- h Length of down pipe

Installation in partially filled pipes

A partially filled pipe with a gradient necessitates a drain-type configuration. The empty pipe detection (EPD) function offers additional protection by detecting empty or partially filled pipes.

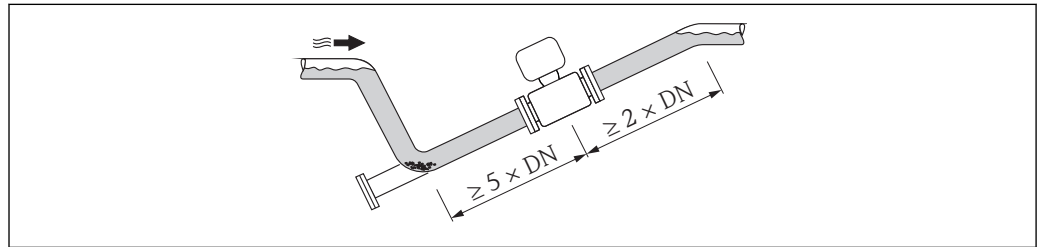

A0017063

Orientation

The direction of the arrow on the sensor nameplate helps you to install the sensor according to the flow direction (direction of medium flow through the piping).

An optimum orientation position helps avoid gas and air accumulations and deposits in the measuring tube.

The measuring device also offers the empty pipe detection function to detect partially filled measuring pipes in the event of outgassing fluids or variable process pressures.

Vertical

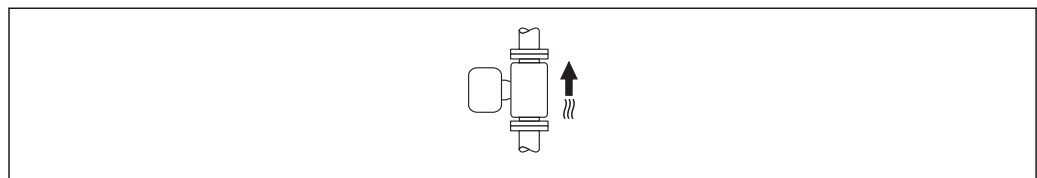

A0015591

This is the optimum for self-emptying piping systems and for use in conjunction with empty pipe detection.

Horizontal

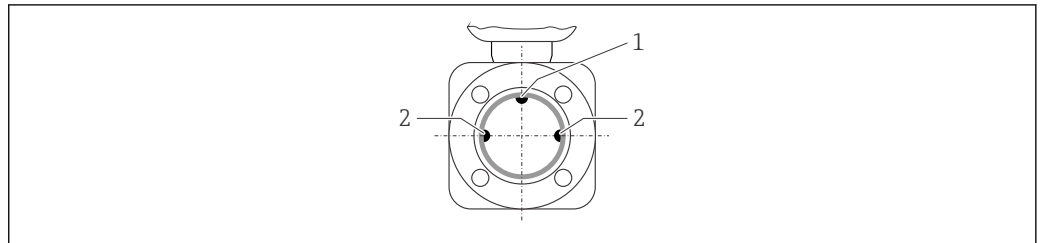

A0019602

- 1 EPD electrode for empty pipe detection
- 2 Measuring electrodes for signal detection

- i** The measuring electrode plane must be horizontal. This prevents brief insulation of the two measuring electrodes by entrained air bubbles.
 - The empty pipe detection only works if the transmitter housing is pointing upwards as otherwise there is no guarantee that the empty pipe detection function will actually respond to a partially filled or empty measuring tube.

Inlet and outlet runs

If possible, install the sensor upstream from fittings such as valves, T-pieces or elbows.

Observe the following inlet and outlet runs to comply with accuracy specifications:

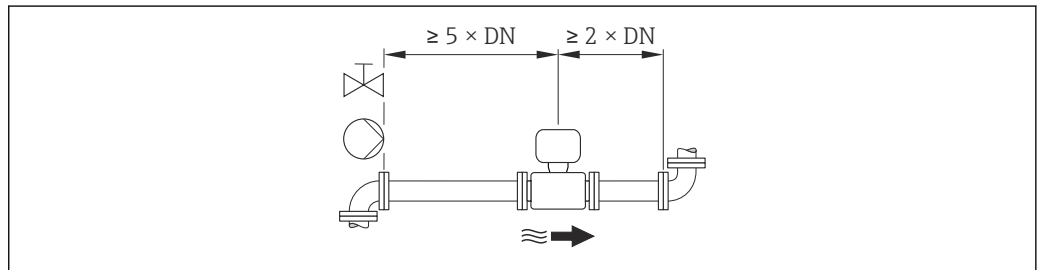

A0016275

Installation dimensions

- i** For the dimensions and installation lengths of the device, see the "Technical Information" document, "Mechanical construction" section

6.1.2 Requirements from environment and process

Ambient temperature range

Transmitter	-40 to +60 °C (-40 to +140 °F)
Sensor	-20 to +60 °C (-4 to +140 °F)
Liner	Do not exceed or fall below the permitted temperature range of the liner (→ 101).

If operating outdoors:

- Install the measuring device in a shady location.
- Avoid direct sunlight, particularly in warm climatic regions.
- Avoid direct exposure to weather conditions.

Temperature tables

SI units

T _a [°C]	T6 [85 °C]	T5 [100 °C]	T4 [135 °C]	T3 [200 °C]	T2 [300 °C]	T1 [450 °C]
30	50	95	130	150	150	150
50	-	95	130	150	150	150
60	-	95	110	110	110	110

US units

T _a [°F]	T6 [185 °F]	T5 [212 °F]	T4 [275 °F]	T3 [392 °F]	T2 [572 °F]	T1 [842 °F]
86	122	203	266	302	302	302
122	-	203	266	302	302	302
140	-	203	230	230	230	230

System pressure

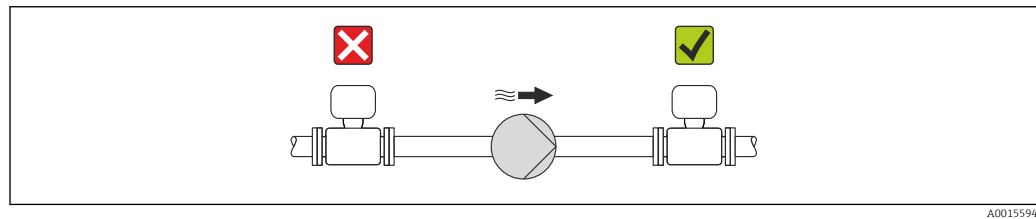

A0015594

Never install the sensor on the pump suction side in order to avoid the risk of low pressure, and thus damage to the liner.

- Furthermore, install pulse dampers if reciprocating, diaphragm or peristaltic pumps are used.
- For information on the liner's resistance to partial vacuum (→ 101)
 - Information on the shock resistance of the measuring system (→ 100)
 - Information on the vibration resistance of the measuring system (→ 100)

Vibrations

In the event of very strong vibrations, the pipe and sensor must be supported and fixed.

- Information on the shock resistance of the measuring system (→ 100)
- Information on the vibration resistance of the measuring system (→ 100)

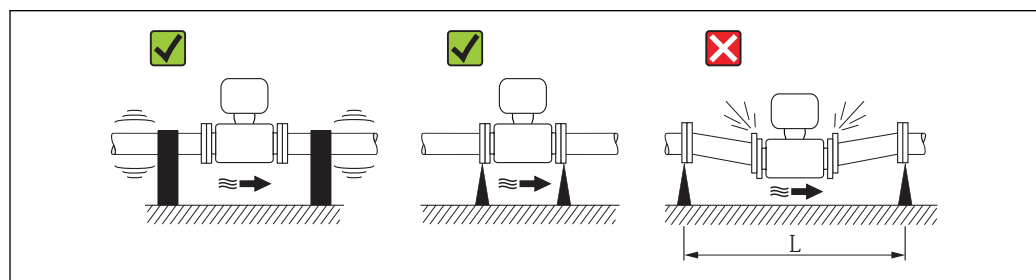

A0016266

5 Measures to avoid device vibrations (L > 10 m (33 ft))

Adapters

Suitable adapters to DIN EN 545 (double-flange reducers) can be used to install the sensor in larger-diameter pipes. The resultant increase in the rate of flow improves measuring accuracy with very slow-moving fluids. The nomogram shown here can be used to calculate the pressure loss caused by reducers and expanders.

i The nomogram only applies to liquids with a viscosity similar to that of water.

1. Calculate the ratio of the diameters d/D .
2. From the nomogram read off the pressure loss as a function of flow velocity (downstream from the reduction) and the d/D ratio.

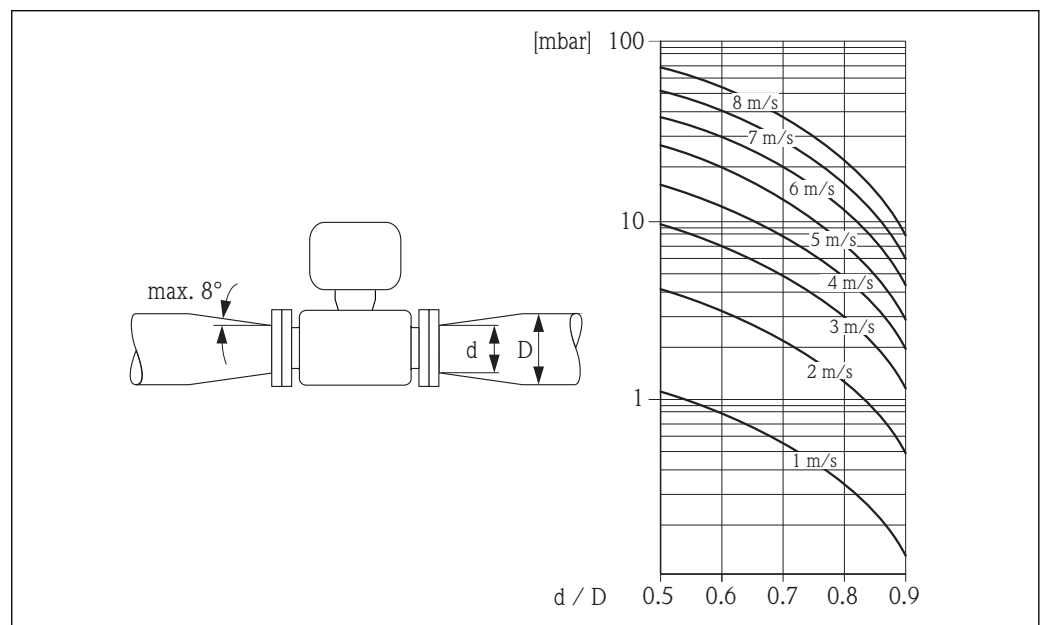

A0016359

6.2 Mounting the measuring device

6.2.1 Required tools

For sensor

For flanges and other process connections:

- Screws, nuts, seals etc. are not included in the scope of supply and must be provided by the customer.
- Appropriate mounting tools

6.2.2 Preparing the measuring device

1. Remove all remaining transport packaging.
2. Remove any protective covers or protective caps present from the sensor.
3. Remove stick-on label on the electronics compartment cover.

6.2.3 Mounting the sensor

⚠ WARNING

Danger due to improper process sealing!

- ▶ Ensure that the inside diameters of the gaskets are greater than or equal to that of the process connections and piping.
 - ▶ Ensure that the gaskets are clean and undamaged.
 - ▶ Install the gaskets correctly.
1. Ensure that the direction of the arrow on the sensor matches the flow direction of the medium.
 2. To ensure compliance with device specifications, install the measuring device between the pipe flanges in a way that it is centered in the measurement section.
 3. Install the measuring device or turn the transmitter housing so that the cable entries do not point upwards.

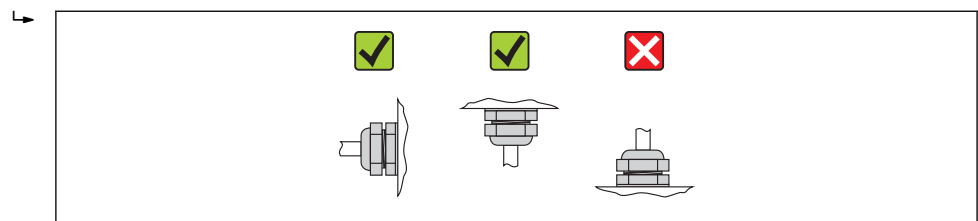

A0013964

The sensor is supplied to order, with or without pre-installed process connections. Pre-installed process connections are firmly secured to the sensor by 4 or 6 hexagonal-headed bolts.

- i** The sensor may need to be supported or additionally secured depending on the application and pipe length. In particular, it is absolutely essential to secure the sensor additionally if plastic process connections are used. An appropriate wall mounting kit can be ordered separately as an accessory from Endress+Hauser (→ [109](#)).

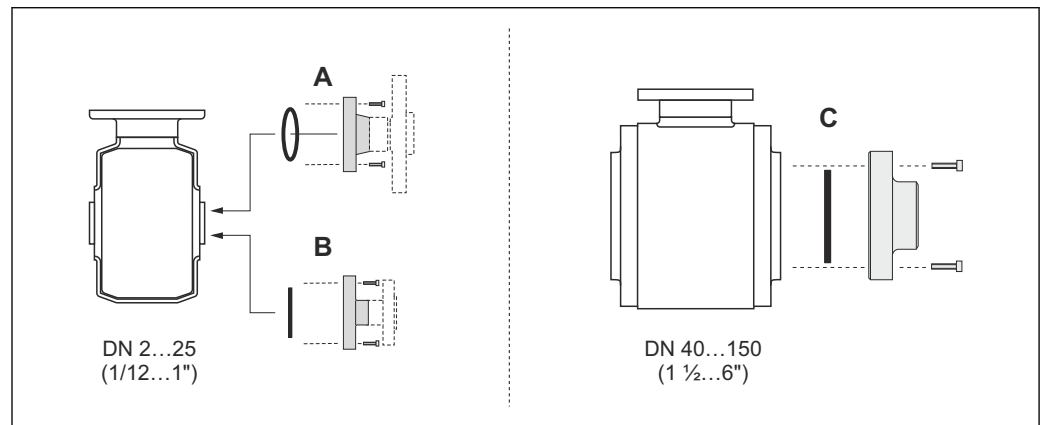

A0019804

6 Process connection seals



- A Process connections with O-ring seal (→ [105](#))
- B Process connections with aseptic molded seal, DN 2 to 25 (1/12 to 1") (→ [105](#))
- C Process connections with aseptic molded seal, DN 40 to 150 (1 1/2 to 6") (→ [105](#))

Welding the sensor into the pipe (welding connections)

⚠ WARNING

Risk of destroying the electronics!

- ▶ Make sure that the welding system is not grounded via the sensor or transmitter.

1. Tack-weld the sensor to secure it in the pipe. A suitable welding aid can be ordered separately as an accessory (→  109).
 2. Release the screws on the process connection flange and remove the sensor, along with the seal, from the pipe.
 3. Weld the process connection into the pipe.
 4. Reinstall the sensor in the pipe, and in doing so make sure that the seal is clean and in the right position.
-  ■ If thin-walled pipes carrying food are welded correctly, the seal is not damaged by the heat even when mounted. Nevertheless it is advisable to remove the sensor and seal.
- It must be possible to open the pipe by approx. 8 mm (0.31 in) in total to permit disassembly.

Cleaning with pigs



It is essential to take the internal diameters of the measuring tube and process connection into account when cleaning with pigs. All the dimensions and lengths of the sensor and transmitter are provided in the separate "Technical Information" document.

Mounting the seals



Comply with the following instructions when installing seals:

- When mounting the process connections, make sure that the seals concerned are clean and centered correctly.
- In the case of metal process connections, the screws must be tightened securely. The process connection forms a metal connection with the sensor, which ensures a defined compression of the seal.
- In the case of plastic process connections, comply with the max. screw tightening torques for lubricated threads: 7 Nm (5.2 lbf ft). In the case of plastic flanges, always insert a seal between the connection and the counterflange.
- Depending on the application the seals should be replaced periodically, particularly if molded seals are used (aseptic version)! The interval between changes depends on the frequency of the cleaning cycles, the cleaning temperature and the medium temperature. Replacement seals can be ordered as an accessory (→  109).

Mounting grounding rings (DN 2 to 25 (1/12 to 1"))

-  Pay attention to the information on potential equalization (→  31).

In the case of plastic process connections (e.g. flange connections or adhesive fittings), additional ground rings must be used to ensure the potential between the sensor and fluid is matched. If grounding rings are not installed, this can affect the measuring accuracy or cause the destruction of the sensor as a result of the electrochemical decomposition of the electrodes.

-  ■ Depending on the option ordered, plastic disks are used instead of grounding rings on some process connections. These plastic disks only act as "spacers" and do not have any potential matching function. Furthermore, they also perform a significant sealing function at the sensor/process connection interface. Therefore, in the case of process connections without metal grounding rings, these plastic disks/seals should never be removed and should always be installed!
- Grounding rings can be ordered separately as an accessory from Endress+Hauser (→  109). When ordering make sure that the grounding rings are compatible with the material used for the electrodes, as otherwise there is the danger that the electrodes could be destroyed by electrochemical corrosion! Material specifications (→  104).
 - Grounding rings, including seals, are mounted inside the process connections. Therefore the installation length is not affected.

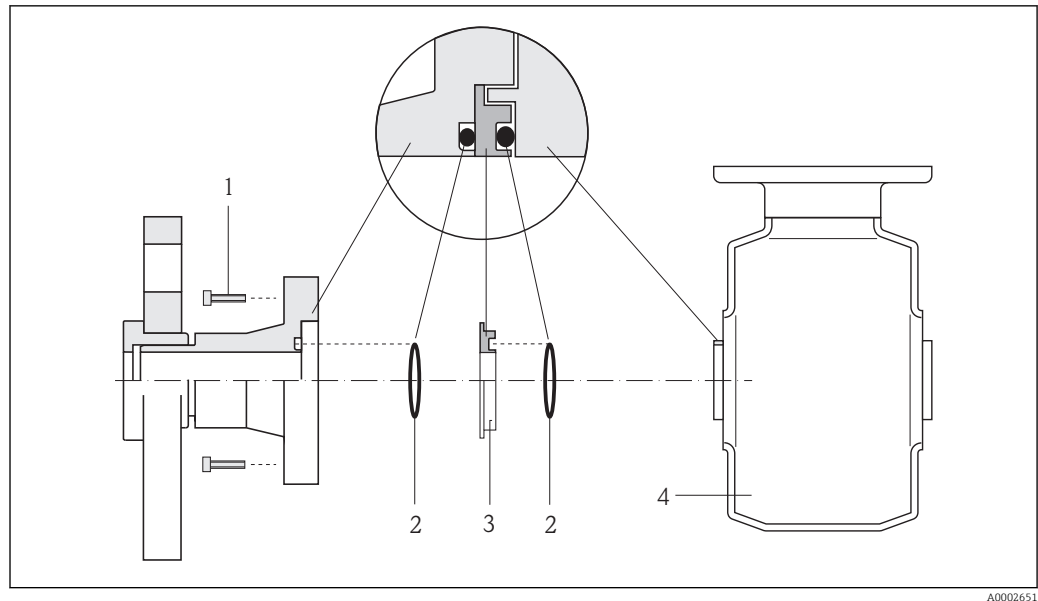

A0002651

7 *Installing grounding rings*

- 1 *Hexagonal-headed bolts of process connection*
- 2 *O-ring seals*
- 3 *Grounding ring or plastic disk (spacer)*
- 4 *Sensor*

1. Release the 4 or 6 hexagonal-headed bolts (1) and remove the process connection from the sensor (4).
2. Remove the plastic disk (3), along with the two O-ring seals (2), from the process connection.
3. Place the first O-ring seal (2) back into the groove of the process connection.
4. Fit the metal grounding ring (3) in the process connection as illustrated.
5. Place the second O-ring seal (2) into the groove of the grounding ring.
6. Mount the process connection back on the sensor. In doing so, make sure you comply with the max. screw tightening torques for lubricated threads: 7 Nm (5.2 lbf ft)

6.2.4 Turning the display module

The display module can be turned to optimize display readability.

Aluminum housing version, AlSi10Mg, coated

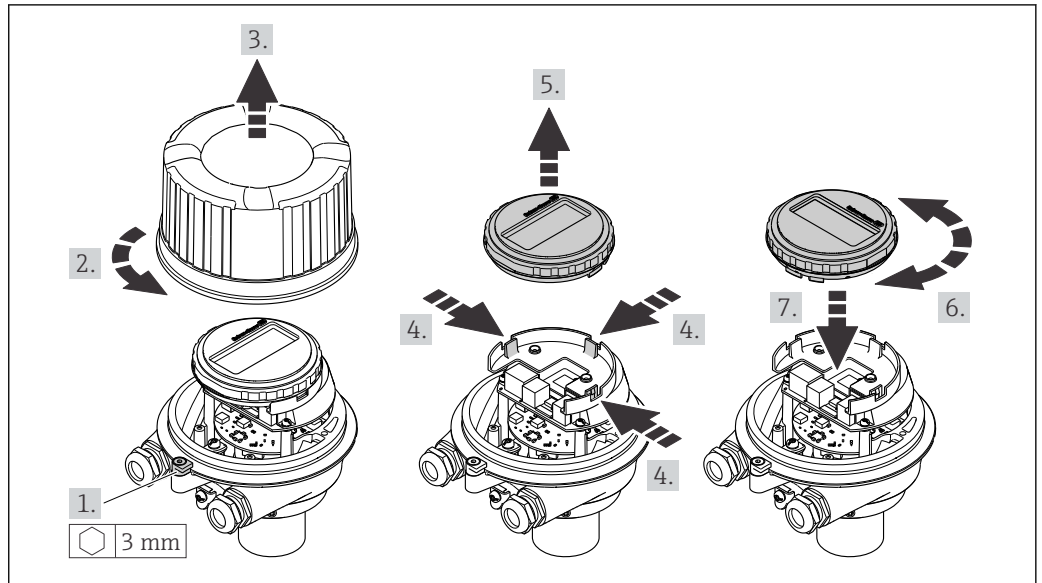

A0023192

Compact and ultra-compact housing version, hygienic, stainless

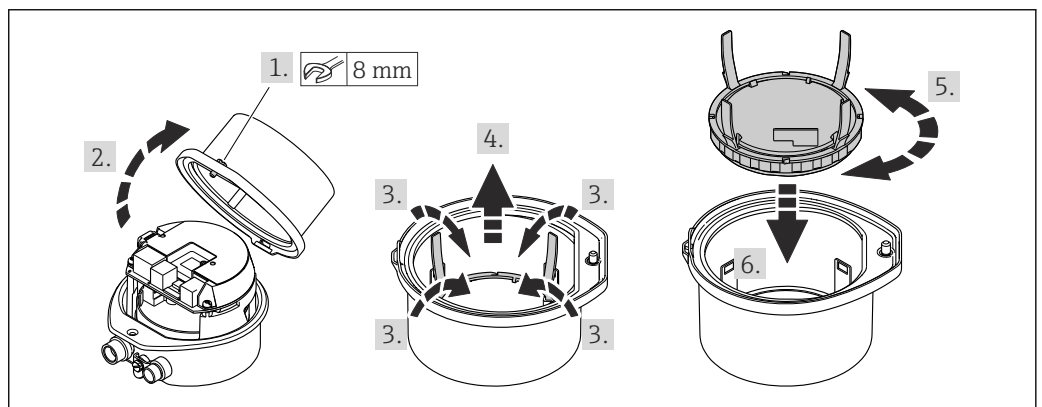

A0023195

6.3 Post-installation check

Is the device undamaged (visual inspection)?	<input type="checkbox"/>
Does the measuring device conform to the measuring point specifications? For example: <ul style="list-style-type: none"> ▪ Process temperature ▪ Process pressure (refer to the section on "Pressure-temperature ratings" in the "Technical Information" document) ▪ Ambient temperature ▪ Measuring range 	<input type="checkbox"/>
Has the correct orientation for the sensor been selected ? <ul style="list-style-type: none"> ▪ According to sensor type ▪ According to medium temperature ▪ According to medium properties (outgassing, with entrained solids) 	<input type="checkbox"/>
Does the arrow on the sensor nameplate match the direction of flow of the fluid through the piping ?	<input type="checkbox"/>

Are the measuring point identification and labeling correct (visual inspection)?	<input type="checkbox"/>
Have the fixing screws been tightened with the correct tightening torque?	<input type="checkbox"/>

7 Electrical connection

 The measuring device does not have an internal circuit breaker. For this reason, assign the measuring device a switch or power-circuit breaker so that the power supply line can be easily disconnected from the mains.

7.1 Connection conditions

7.1.1 Required tools

- For cable entries: Use corresponding tools
- For securing clamp (on aluminum housing): Allen screw 3 mm
- For securing screw (for stainless steel housing): open-ended wrench 8 mm
- Wire stripper
- When using stranded cables: crimping tool for ferrule

7.1.2 Requirements for connecting cable

The connecting cables provided by the customer must fulfill the following requirements.

Electrical safety

In accordance with applicable federal/national regulations.

Permitted temperature range

- -40 °C (-40 °F) to $+80\text{ °C}$ ($+176\text{ °F}$)
- Minimum requirement: cable temperature range \geq ambient temperature +20 K

Power supply cable

Standard installation cable is sufficient.

Signal cable

Current output

For 4-20 mA HART: Shielded cable recommended. Observe grounding concept of the plant.

Pulse/frequency/switch output

Standard installation cable is sufficient.

Cable diameter

- Cable glands supplied:
M20 \times 1.5 with cable ϕ 6 to 12 mm (0.24 to 0.47 in)
- Spring terminals:
Wire cross-sections 0.5 to 2.5 mm² (20 to 14 AWG)

7.1.3 Terminal assignment

Transmitter

Connection version 4-20 mA HART with pulse/frequency/switch output

Order code for "Output", option B

Depending on the housing version, the transmitters can be ordered with terminals or device plugs.

Order code for "Housing"	Connection methods available		Possible options for order code "Electrical connection"
	Outputs	Power supply	
Options A, B	Terminals	Terminals	<ul style="list-style-type: none"> ▪ Option A: coupling M20x1 ▪ Option B: thread M20x1 ▪ Option C: thread G ½" ▪ Option D: thread NPT ½"
Options A, B	Device plug	Terminals	<ul style="list-style-type: none"> ▪ Option L: plug M12x1 + thread NPT ½" ▪ Option N: plug M12x1 + coupling M20 ▪ Option P: plug M12x1 + thread G ½" ▪ Option U: plug M12x1 + thread M20
Options A, B, C	Device plug	Device plug	Option Q: 2 x plug M12x1

Order code for "Housing":

- Option A: compact, coated aluminum
- Option B: compact, hygienic, stainless
- Option C: ultra compact, hygienic, stainless, M12 device plug

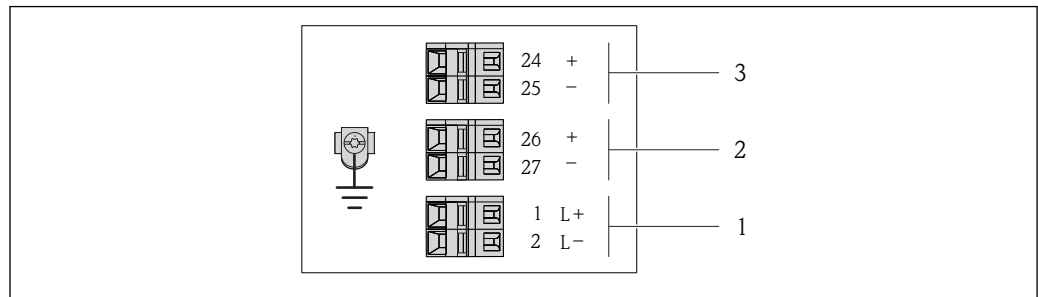

A0016888

8 Terminal assignment 4-20 mA HART with pulse/frequency/switch output

- 1 Power supply: DC 24 V
- 2 Output 1: 4-20 mA HART (active)
- 3 Output 2: pulse/frequency/switch output (passive)

Order code for "Output"	Terminal number					
	Power supply		Output 1		Output 2	
	2 (L-)	1 (L+)	27 (-)	26 (+)	25 (-)	24 (+)
Option B	DC 24 V		4-20 mA HART (active)		Pulse/frequency/switch output (passive)	

Order code for "Output":
Option B: 4-20 mA HART with pulse/frequency/switch output

7.1.4 Pin assignment, device plug

4-20 mA HART with pulse/frequency/switch output

Device plug for supply voltage (device side)

Pin	Assignment		Coding	Plug/socket
1	L+	DC24 V	A	Plug
2				
3				
4	L-	DC24 V		
5		Grounding/shielding		

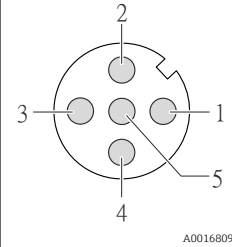

A0016809

Device plug for signal transmission (device side)

Pin	Assignment		Coding	Plug/socket
1	+	4-20 mA HART (active)	A	Socket
2	-	4-20 mA HART (active)		
3	+	Pulse/frequency/switch output (passive)		
4	-	Pulse/frequency/switch output (passive)		
5		Grounding/shielding		

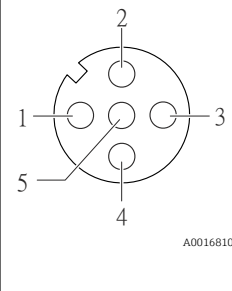

A0016810

7.1.5 Preparing the measuring device

1. Remove dummy plug if present.
2. **NOTICE!** Insufficient sealing of the housing! Operational reliability of the measuring device could be compromised. Use suitable cable glands corresponding to the degree of protection.
If measuring device is delivered without cable glands:
Provide suitable cable gland for corresponding connecting cable (→ 27).
3. If measuring device is delivered with cable glands:
Observe cable specification (→ 27).

7.2 Connecting the measuring device

NOTICE

Limitation of electrical safety due to incorrect connection!

- ▶ Have electrical connection work carried out by correspondingly trained specialists only.
- ▶ Observe applicable federal/national installation codes and regulations.
- ▶ Comply with local workplace safety regulations.
- ▶ For use in potentially explosive atmospheres, observe the information in the device-specific Ex documentation.

7.2.1 Connecting the transmitter

The connection of the transmitter depends on the following order codes:

- Housing version: compact or ultra-compact
- Connection version: device plug or terminals

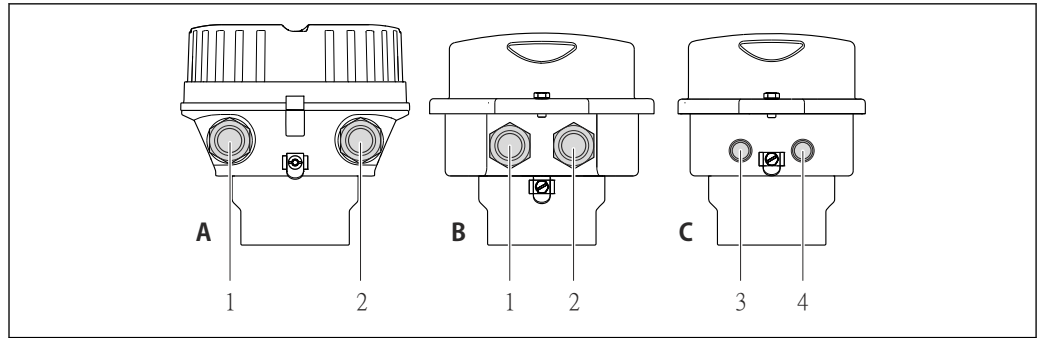

A0016924

9 Device versions and connection versions

- A Housing version: compact, aluminum coated
- B Housing version: compact hygienic, stainless
- 1 Cable entry or device plug for signal transmission
- 2 Cable entry or device plug for supply voltage
- C Housing version: ultra-compact hygienic, stainless, M12 device plug
- 3 Device plug for signal transmission
- 4 Device plug for supply voltage

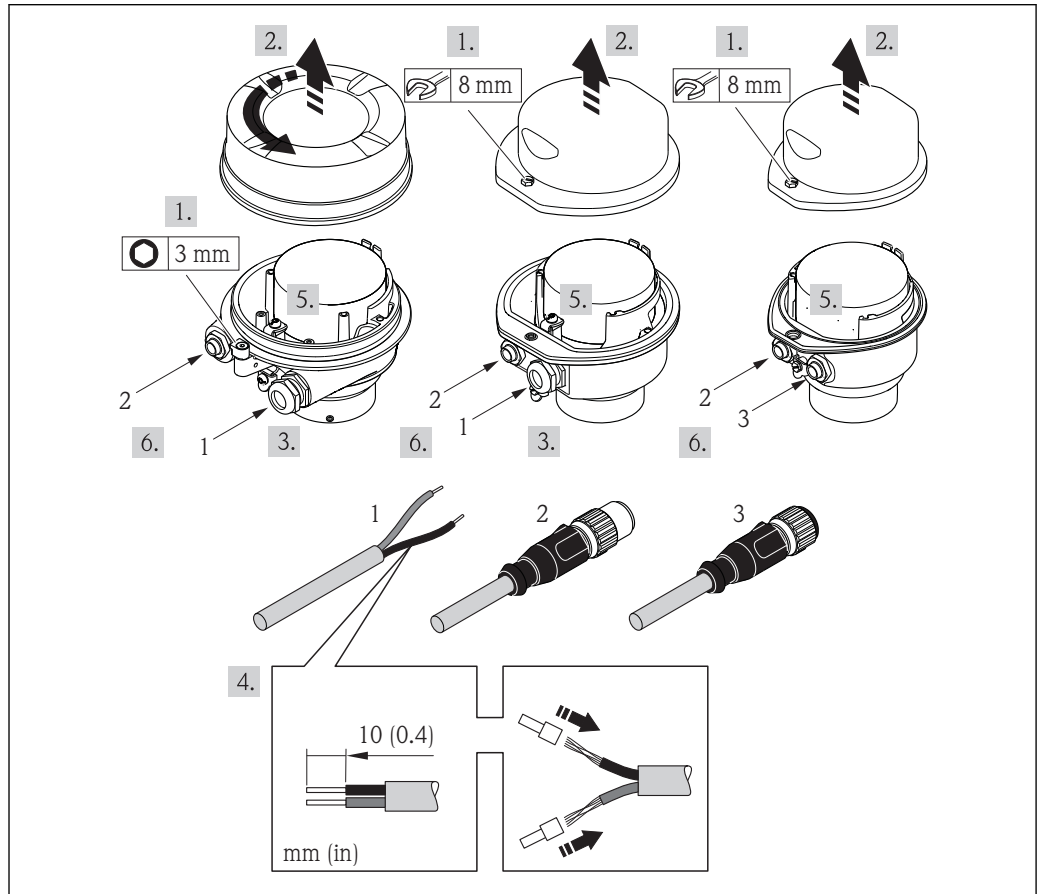

A0017844

10 Device versions with connection examples

- 1 Cable
- 2 Device plug for signal transmission
- 3 Device plug for supply voltage

For device version with device plug: only pay attention to Step 6.

- 1. Depending on the housing version, loosen the securing clamp or fixing screw of the housing cover.

2. Depending on the housing version, unscrew or open the housing cover and disconnect the local display from the main electronics module where necessary (→  106).
3. Push the cable through the cable entry . To ensure tight sealing, do not remove the sealing ring from the cable entry.
4. Strip the cable and cable ends. In the case of stranded cables, also fit ferrules.
5. Connect the cable in accordance with the terminal assignment or the device plug pin assignment .
6. Depending on the device version: tighten the cable glands or plug in the device plug and tighten .
7. **WARNING!** Housing degree of protection may be voided due to insufficient sealing of the housing. Screw in the screw without using any lubricant. The threads on the cover are coated with a dry lubricant.
Reverse the removal procedure to reassemble the transmitter.

7.2.2 Ensuring potential equalization

CAUTION

Electrode damage can result in the complete failure of the device!

- ▶ Make sure that the fluid and sensor have the same electrical potential.
- ▶ Pay attention to internal grounding concepts in the company.
- ▶ Pay attention to the pipe material or grounding.

Connection examples for standard situations

Metal process connections

Potential matching usually takes place via the metallic process connections in contact with medium which are directly mounted on the measuring transmitter. This usually means that additional potential matching measures are unnecessary.

Connection example in special situations

Plastic process connections

In the case of plastic process connections, additional grounding rings or process connections with an integrated grounding electrode must be used to ensure potential matching between the sensor and the fluid. If there is no potential matching, this can affect the measuring accuracy or cause the destruction of the sensor as a result of the electrochemical decomposition of the electrodes.

Note the following when using grounding rings:

- Depending on the option ordered, plastic disks are used instead of grounding rings on some process connections. These plastic disks only act as "spacers" and do not have any potential matching function. Furthermore, they also perform a significant sealing function at the sensor/connection interface. Therefore, in the case of process connections without metal grounding rings, these plastic disks/seals should never be removed and should always be installed!
- Grounding rings can be ordered separately as an accessory from Endress+Hauser . When ordering make sure that the grounding rings are compatible with the material used for the electrodes, as otherwise there is the danger that the electrodes could be destroyed by electrochemical corrosion!
- Grounding rings, including seals, are mounted inside the process connections. Therefore the installation length is not affected.

Potential equalization via additional grounding ring

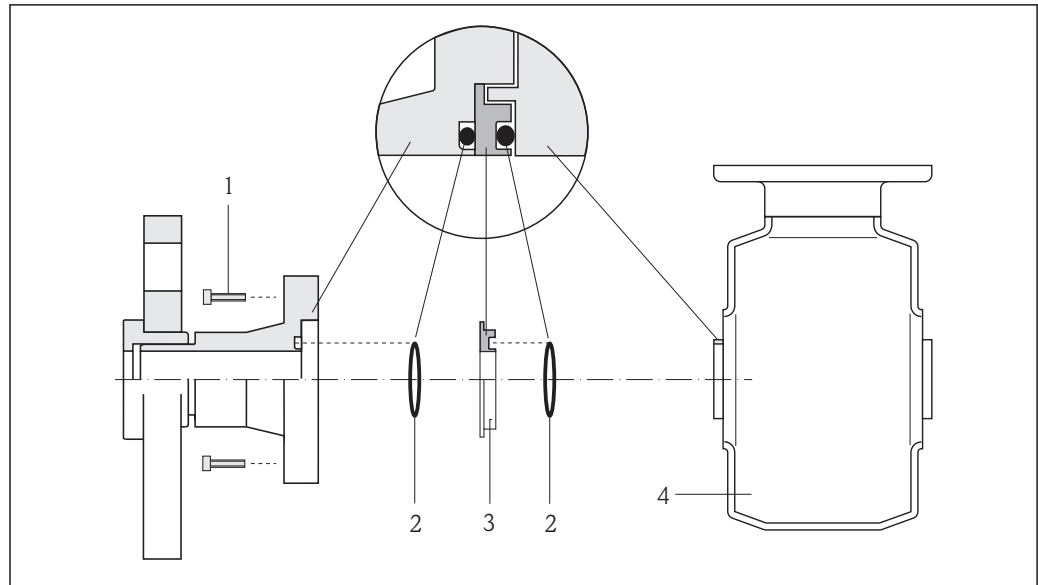

A0002651

- 1 Hexagonal-headed bolts of process connection
- 2 O-ring seals
- 3 Plastic disk (spacer) or grounding ring
- 4 Sensor

Potential equalization via grounding electrodes on process connection

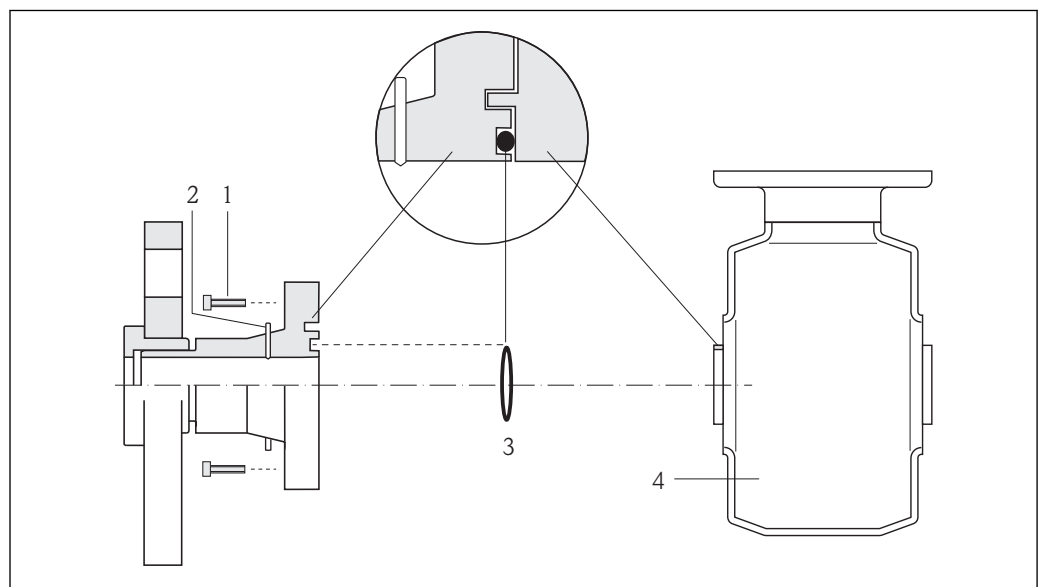

A0017293

- 1 Hexagonal-headed bolts of process connection
- 2 Integrated grounding electrodes
- 3 O-ring seal
- 4 Sensor

7.3 Special connection instructions

7.3.1 Connection examples

7.4 Ensuring the degree of protection

The measuring device fulfills all the requirements for the IP66/67 degree of protection, Type 4X enclosure.

To guarantee IP66/67 degree of protection, Type 4X enclosure, carry out the following steps after the electrical connection:

1. Check that the housing seals are clean and fitted correctly. Dry, clean or replace the seals if necessary.
2. Tighten all housing screws and screw covers.
3. Firmly tighten the cable glands.
4. To ensure that moisture does not enter the cable entry, route the cable so that it loops down before the cable entry ("water trap").

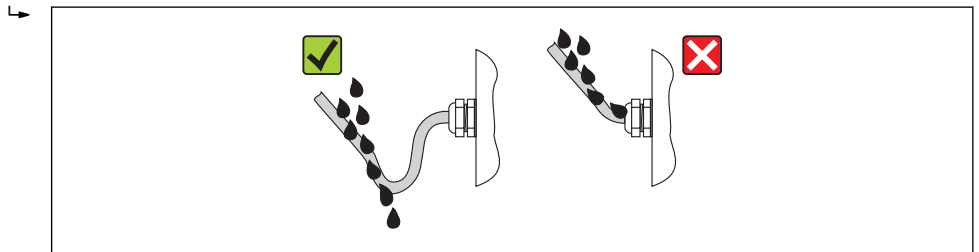

A0013960

5. Insert dummy plugs into unused cable entries.

7.5 Post-connection check

Are cables or the device undamaged (visual inspection)?	<input type="checkbox"/>
Do the cables comply with the requirements (→ 27)?	<input type="checkbox"/>
Do the cables have adequate strain relief?	<input type="checkbox"/>
Are all the cable glands installed, firmly tightened and leak-tight? Cable run with "water trap" (→ 33)?	<input type="checkbox"/>
Depending on the device version: are all the device plugs firmly tightened (→ 29)?	<input type="checkbox"/>
Does the supply voltage match the specifications on the transmitter nameplate (→ 97)?	<input type="checkbox"/>
Is the terminal assignment or the pin assignment of the device plug correct?	<input type="checkbox"/>
If supply voltage is present, is the power LED on the electronics module of the transmitter lit green (→ 11)?	<input type="checkbox"/>
Is the potential equalization established correctly (→ 31)?	<input type="checkbox"/>
Depending on the device version, is the securing clamp or fixing screw firmly tightened?	<input type="checkbox"/>

8 Operation options

8.1 Overview of operation options

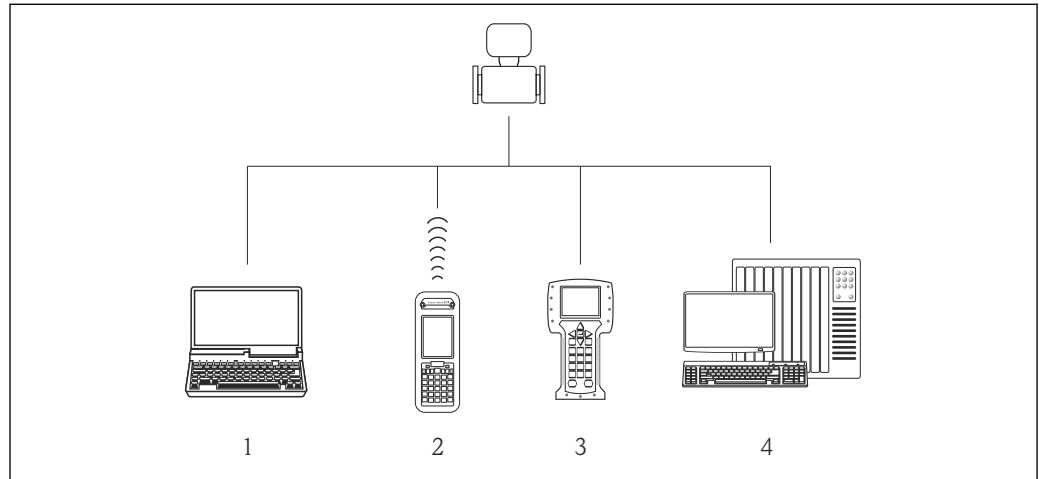

A0019598

- 1 Computer with Web browser (e.g. Internet Explorer) or with operating tool (e.g. FieldCare, AMS Device Manager, SIMATIC PDM)
- 2 Field Xpert SFX350 or SFX370
- 3 Field Communicator 475
- 4 Control system (e.g. PLC)

8.2 Structure and function of the operating menu

8.2.1 Structure of the operating menu

 For an overview of the operating menu with menus and parameters

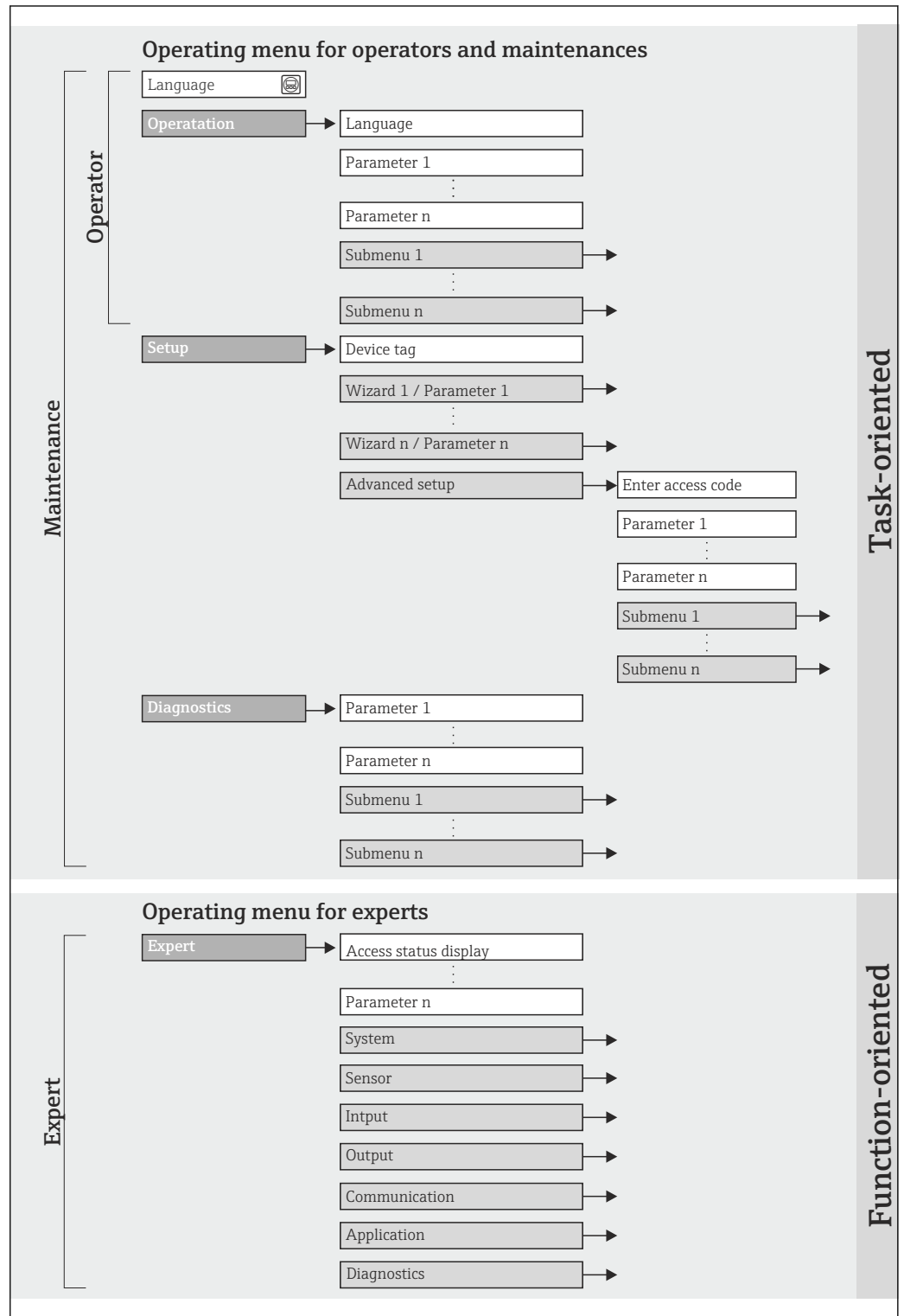

 11 Schematic structure of the operating menu

A0018237-EN

8.2.2 Operating philosophy

The individual parts of the operating menu are assigned to certain user roles. Each user role corresponds to typical tasks within the device lifecycle.

Menu		User role and tasks	Content/meaning
Language	task-oriented	Role "Operator", "Maintenance" Tasks during operation:	Defining the operating language
Operation		<ul style="list-style-type: none"> ▪ Configuring the operational display ▪ Reading measured values 	<ul style="list-style-type: none"> ▪ Configuring the operational display (e.g. display format, display contrast) ▪ Resetting and controlling totalizers
Setup		"Maintenance" role Commissioning:	"Advanced setup" submenu:
Diagnostics		<ul style="list-style-type: none"> ▪ Configuration of the measurement ▪ Configuration of the inputs and outputs 	<ul style="list-style-type: none"> ▪ For more customized configuration of the measurement (adaptation to special measuring conditions) ▪ Configuration of totalizers ▪ Configuration of electrode cleaning (optional) ▪ Administration (define access code, reset measuring device)
		"Maintenance" role Fault elimination:	Contains all parameters for error detection and analyzing process and device errors:
		<ul style="list-style-type: none"> ▪ Diagnostics and elimination of process and device errors ▪ Measured value simulation 	<ul style="list-style-type: none"> ▪ "Diagnostic list" submenu Contains up to 5 currently pending diagnostic messages. ▪ "Event logbook" submenu Contains up to 20 or 100 (order option "Extended HistoROM") event messages that have occurred. ▪ "Device information" submenu Contains information for identifying the device. ▪ "Measured values" submenu Contains all current measured values. ▪ "Data logging" submenu (order option "Extended HistoROM") Storage and visualization of up to 1000 measured values ▪ "Heartbeat Technology" submenu The functionality of the device is checked on demand and the verification results are documented. ▪ "Simulation" submenu Is used to simulate measured values or output values.
Expert	function-oriented	Tasks that require detailed knowledge of the function of the device:	Contains all the parameters of the device and makes it possible to access these parameters directly using an access code. The structure of this menu is based on the function blocks of the device:
		<ul style="list-style-type: none"> ▪ Commissioning measurements under difficult conditions ▪ Optimal adaptation of the measurement to difficult conditions ▪ Detailed configuration of the communication interface ▪ Error diagnostics in difficult cases 	<ul style="list-style-type: none"> ▪ "System" submenu Contains all higher-order device parameters that do not pertain either to measurement or the measured value communication. ▪ "Sensor" submenu Configuration of the measurement. ▪ "Application" submenu Configuration of the functions that go beyond the actual measurement (e.g. totalizer). ▪ "Diagnostics" submenu Error detection and analysis of process and device errors and for device simulation and Heartbeat Technology.

8.3 Access to the operating menu via the Web browser

8.3.1 Function range

Thanks to the integrated Web server the device can be operated and configured via a Web browser. In addition to the measured values, status information on the device is also displayed and allows the user to monitor the status of the device. Furthermore the device data can be managed and the network parameters can be configured.

8.3.2 Prerequisites

Hardware

Connecting cable	Standard Ethernet cable with RJ45 connector
Computer	RJ45 interface
Measuring device:	Web server must be enabled; factory setting: ON  For information on enabling the Web server (→ 39)

Software of the computer

Web browsers supported	<ul style="list-style-type: none"> ▪ Microsoft Internet Explorer (min. 8.x) ▪ Mozilla Firefox ▪ Google chrome
Recommended operating systems	<ul style="list-style-type: none"> ▪ Windows XP ▪ Windows 7
User rights for TCP/IP settings	User rights required for TCP/IP settings (e.g. for changes to IP address, subnet mask)
Computer configuration	<ul style="list-style-type: none"> ▪ JavaScript is enabled ▪ If JavaScript cannot be enabled, enter http://XXX.XXX.X.XXX/basic.html in the address line of the Web browser, e.g. http://192.168.1.212/basic.html. A fully functional but simplified version of the operating menu structure starts in the Web browser.

 When installing a new firmware version:
 To enable correct data display, clear the temporary memory (cache) of the Web browser under **Internet options**.

8.3.3 Establishing a connection

Configuring the Internet protocol of the computer

The following information refers to the default Ethernet settings of the device.

IP address of the device: 192.168.1.212 (factory setting)

IP address	192.168.1.XXX; for XXX all numerical values except: 0, 212 and 255 → e.g. 192.168.1.213
Subnet mask	255.255.255.0
Default gateway	192.168.1.212 or leave cells empty

1. Switch on the measuring device and connect to the computer via the cable (→ 41).
2. If a 2nd network card is not used: all the applications on the notebook should be closed, or all the applications that require the Internet or network, such as e-mail, SAP applications, Internet or Windows Explorer, i.e. close all open Internet browsers.
3. Configure the properties of the Internet protocol (TCP/IP) as defined in the table above.

Starting the Web browser

1. Start the Web browser on the computer.
2. Enter the IP address of the Web server in the address line of the Web browser: 192.168.1.212

The login page appears.

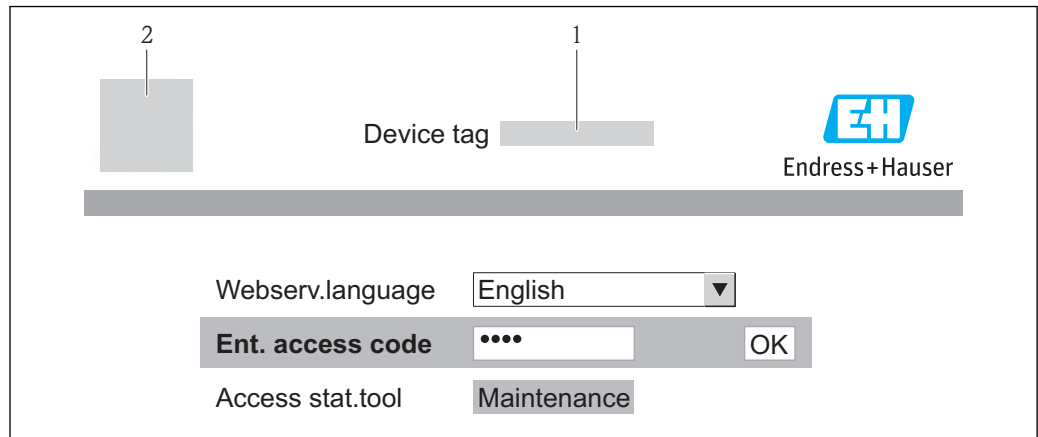

A0017362

- 1 Device tag (→ 📄 49)
- 2 Picture of device

 If a login page does not appear, or if the page is incomplete (→ 📄 75)

8.3.4 Logging on

1. Select the preferred operating language for the Web browser.
2. Enter the access code.
3. Press **OK** to confirm your entry.

Access code	0000 (factory setting); can be changed by customer (→ 📄 69)
--------------------	---

 If no action is performed for 10 minutes, the Web browser automatically returns to the login page.

8.3.5 User interface

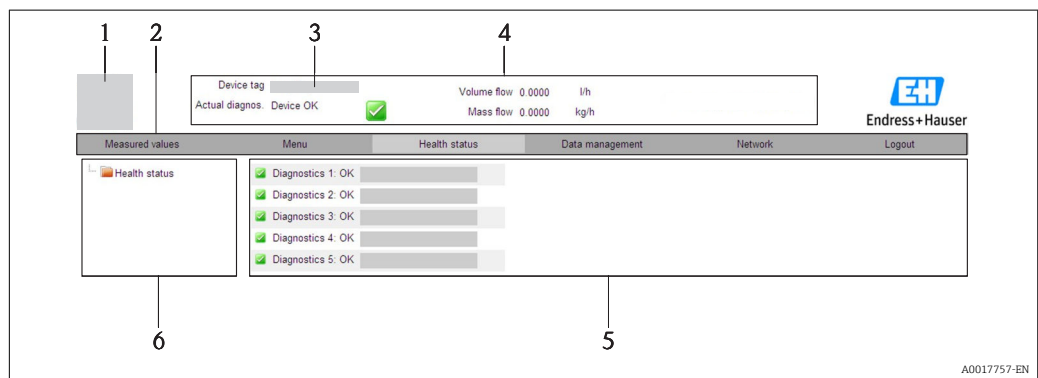

A0017757-EN

- 1 Picture of device
- 2 Function row with 6 functions
- 3 Device tag
- 4 Header
- 5 Working area
- 6 Navigation area

Header

The following information appears in the header:

- Device tag (→ ⓘ 49)
- Device status with status signal (→ ⓘ 77)
- Current measured values (→ ⓘ 71)

Function row

Functions	Meaning
Measured values	The measured values of the device are displayed
Menu	Access to the operating menu structure of the device, same as for the operating tool
Device status	Displays the diagnostic messages currently pending, listed in order of priority
Data management	Data exchange between PC and measuring device: <ul style="list-style-type: none"> - Upload the configuration from the device (XML format, create configuration back-up) - Save the configuration to the device (XML format, restore configuration) - Export the event list (.csv file) - Export parameter settings (.csv file, create documentation of the measuring point configuration) - Export the Heartbeat verification log (PDF file, only available with the "Heartbeat Verification" application package)
Network configuration	Configuration and checking of all the parameters required for establishing the connection to the device: <ul style="list-style-type: none"> ■ Network settings (e.g. IP address, MAC address) ■ Device information (e.g. serial number, firmware version)
Logout	End the operation and call up the login page

Navigation area

If a function is selected in the function bar, the submenus of the function open in the navigation area. The user can now navigate through the menu structure.

Working area

Depending on the selected function and the related submenus, various actions can be performed in this area:

- Configuring parameters
- Reading measured values
- Calling up help text
- Starting an upload/download

8.3.6 Disabling the Web server

The Web server for the measuring device can enabled and disabled as required via the **Web server functionality** parameter.

Navigation

"Expert" menu → Communication → Web server

Parameter overview with brief description

Parameter	Description	Selection	Factory setting
Web server functionality	Switch the Web server on and off.	<ul style="list-style-type: none"> ■ Off ■ On 	On

Enabling the Web server

If the Web server is disabled it can only be re-enabled with the **Web server functionality** parameter via the following operating options:
Via "FieldCare" operating tool

8.3.7 Logging out

i Before logging out, perform a data backup via the **Data management** function (upload configuration from device) if necessary.

1. Select the **Logout** entry in the function row.
↳ The home page with the Login box appears.
2. Close the Web browser.
3. Reset the modified properties of the Internet protocol (TCP/IP) if they are no longer needed (→ 37).

8.4 Access to the operating menu via the operating tool

8.4.1 Connecting the operating tool

Via HART protocol

This communication interface is present in the following device version:
Order code for "Output", option **B**: 4-20 mA HART, pulse/frequency/switch output

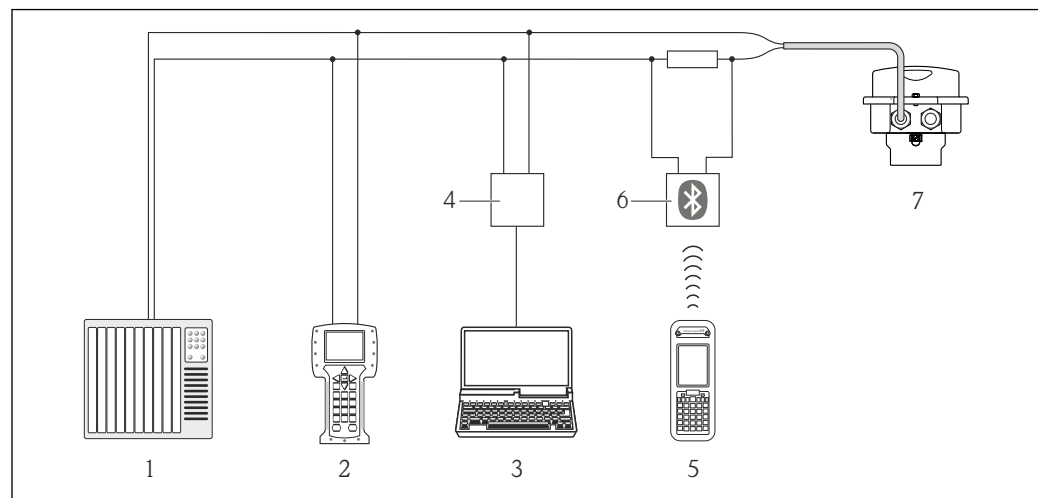

A0016948

12 Options for remote operation via HART protocol

- 1 Control system (e.g. PLC)
- 2 Field Communicator 475
- 3 Computer with operating tool (e.g. FieldCare, AMS Device Manager, SIMATIC PDM)
- 4 Commubox FXA195 (USB)
- 5 Field Xpert SFX350 or SFX370
- 6 VIATOR Bluetooth modem with connecting cable
- 7 Transmitter

Via service interface (CDI-RJ45)

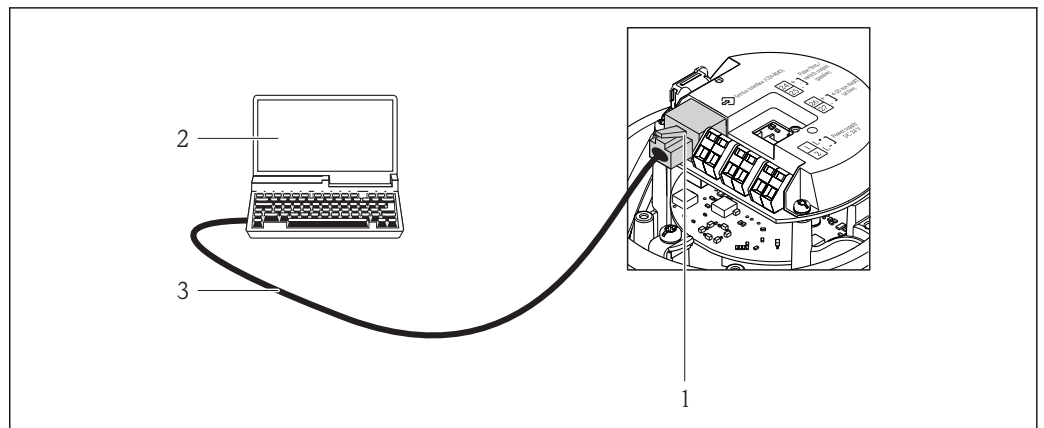

13 Connection for the order code for "Output", option B: 4-20 mA HART, pulse/frequency/switch output

- 1 Service interface (CDI -RJ45) of the measuring device with access to the integrated Web server
- 2 Computer with Web browser (e.g. Internet Explorer) for accessing the integrated device Web server or with "FieldCare" operating tool with COM DTM "CDI Communication TCP/IP"
- 3 Standard Ethernet connecting cable with RJ45 plug

8.4.2 Field Xpert SFX350, SFX370

Function scope

Field Xpert SFX350 and Field Xpert SFX370 are mobile computers for commissioning and maintenance. They enable efficient device configuration and diagnostics for HART and FOUNDATION fieldbus devices in the **non-Ex area** (SFX350, SFX370) and the **Ex area** (SFX370).

 For details, see Operating Instructions BA01202S

Source for device description files



See data (→  45)

8.4.3 FieldCare

Function scope

FDT-based plant asset management tool from Endress+Hauser. It can configure all smart field devices in a system and helps you manage them. By using the status information, it is also a simple but effective way of checking their status and condition.

Access takes place via:

- HART protocol (→  40)
- Service interface CDI-RJ45 (→  41)

Typical functions:

- Configuring parameters of transmitters
- Loading and saving device data (upload/download)
- Documentation of the measuring point
- Visualization of the measured value memory (line recorder) and event logbook

 For details, see Operating Instructions BA00027S and BA00059S

Source for device description files

See data (→  45)

Establishing a connection

Via service interface (CDI-RJ45)

1. Start FieldCare and launch the project.
2. In the network: Add a device.
 - ↳ The **Add device** window opens.
3. Select the **CDI Communication TCP/IP** option from the list and press **OK** to confirm.
4. Right-click **CDI Communication TCP/IP** and select the **Add device** option in the context menu that opens.
5. Select the desired device from the list and press **OK** to confirm.
 - ↳ The **CDI Communication TCP/IP (Configuration)** window opens.
6. Enter the device address in the **IP address** field and press **Enter** to confirm:
192.168.1.212 (factory setting); if the IP address is not known .
7. Establish the online connection to the device.



For details, see Operating Instructions BA00027S and BA00059S

User interface

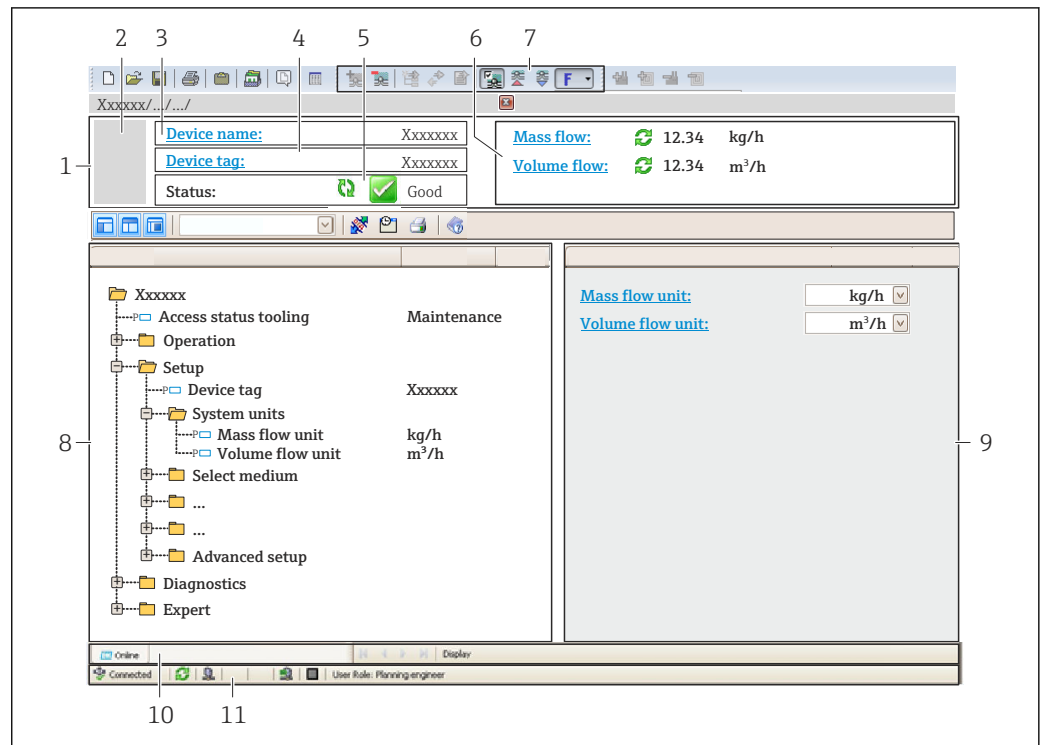

A0021051-EN

- 1 Header
- 2 Picture of device
- 3 Device name
- 4 Device tag (→ 49)
- 5 Status area with status signal (→ 77)
- 6 Display area for current measured values
- 7 Event list with additional functions such as save/load, events list and document creation
- 8 Navigation area with operating menu structure
- 9 Operating range
- 10 Range of action
- 11 Status area

8.4.4 AMS Device Manager

Function scope

Program from Emerson Process Management for operating and configuring measuring devices via HART protocol.

Source for device description files

See data (→ 45)

8.4.5 SIMATIC PDM

Function scope

SIMATIC PDM is a standardized, manufacturer-independent program from Siemens for the operation, configuration, maintenance and diagnosis of intelligent field devices via HART protocol.

Source for device description files

See data (→ 45)

8.4.6 Field Communicator 475

Function scope

Industrial handheld terminal from Emerson Process Management for remote configuration and measured value display via HART protocol.

Source for device description files

See data (→  45)

9 System integration

9.1 Overview of device description files

9.1.1 Current version data for the device

Firmware version	01.01.zz	<ul style="list-style-type: none"> ▪ On the title page of the Operating instructions ▪ On transmitter nameplate(→ 12) ▪ Parameter firmware version Diagnostics → Device info → Firmware version
Release date of firmware version	06.2014	---
Manufacturer ID	0x11	Manufacturer ID parameter Diagnostics → Device info → Manufacturer ID
Device type ID	0x3A	Device type parameter Diagnostics → Device info → Device type
HART protocol revision	7	---
Device revision	2	<ul style="list-style-type: none"> ▪ On transmitter nameplate(→ 12) ▪ Device revision parameter Diagnostics → Device info → Device revision

9.1.2 Operating tools

The suitable device description file for the individual operating tools is listed in the table below, along with information on where the file can be acquired.

Operating tool via HART protocol	Sources for obtaining device descriptions
<ul style="list-style-type: none"> ▪ Field Xpert SFX350 ▪ Field Xpert SFX370 	Use update function of handheld terminal
FieldCare	<ul style="list-style-type: none"> ▪ www.endress.com → Download Area ▪ CD-ROM (contact Endress+Hauser) ▪ DVD (contact Endress+Hauser)
AMS Device Manager (Emerson Process Management)	www.endress.com → Download Area
SIMATIC PDM (Siemens)	www.endress.com → Download Area
Field Communicator 475 (Emerson Process Management)	Use update function of handheld terminal

9.2 Measured variables via HART protocol

The following measured variables (HART device variables) are assigned to the dynamic variables at the factory:

Dynamic variables	Measured variables (HART device variables)
Primary dynamic variable (PV)	Volume flow
Secondary dynamic variable (SV)	Totalizer 1
Tertiary dynamic variable (TV)	Totalizer 2
Quaternary dynamic variable (QV)	Totalizer 3

The assignment of the measured variables to the dynamic variables can be modified and assigned as desired via local operation and the operating tool using the following parameters:

- Expert → Communication → HART output → Output → Assign PV
- Expert → Communication → HART output → Output → Assign SV
- Expert → Communication → HART output → Output → Assign TV
- Expert → Communication → HART output → Output → Assign QV

The following measured variables can be assigned to the dynamic variables:

Measured variables for PV (primary dynamic variable)

- Off
- Volume flow
- Mass flow
- Corrected volume flow
- Flow velocity
- Corrected conductivity
- Temperature
- Electronic temperature

Measured variables for SV, TV, QV (secondary, tertiary and quaternary dynamic variable)

- Volume flow
- Mass flow
- Corrected volume flow
- Flow velocity
- Corrected conductivity
- Temperature
- Electronic temperature
- Totalizer 1
- Totalizer 2
- Totalizer 3



The range of options increases if the measuring device has one or more application packages.

Device variables

The device variables are permanently assigned. A maximum of 8 device variables can be transmitted:

- 0 = volume flow
- 1 = mass flow
- 2 = corrected volume flow
- 3 = flow velocity
- 4 = conductivity
- 5 = corrected conductivity
- 6 = temperature
- 7 = electronic temperature
- 8 = totalizer 1
- 9 = totalizer 2
- 10 = totalizer 3

9.3 Other settings

9.3.1 Burst mode functionality in accordance with HART 7 Specification

Navigation

"Expert" menu → Communication → HART output → Burst configuration → Burst configuration 1 to 3

Structure of the submenu

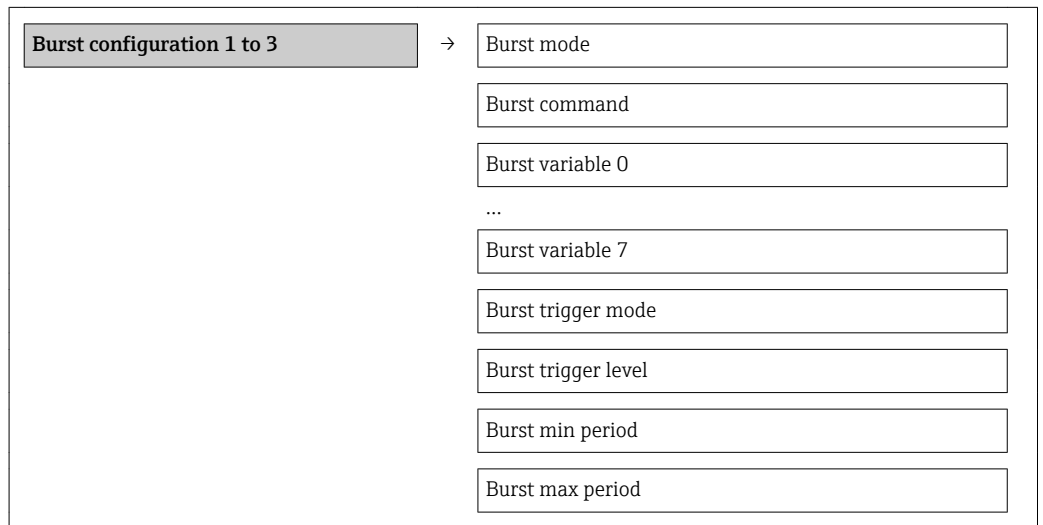

Parameter overview with brief description

Parameter	Description	Selection / User entry	Factory setting
Burst mode #	Activation of the HART burst mode for burst message X.  An external pressure or temperature sensor must also be in the Burst mode.	<ul style="list-style-type: none"> ▪ Off ▪ On 	Off
Burst command #	Select the HART command that is sent to the HART master. <ul style="list-style-type: none"> ▪ Command 1 option: Read out the primary variable. ▪ Command 2 option: Read out the current and the main measured value as a percentage. ▪ Command 3 option: Read out the dynamic HART variables and the current. ▪ Command 9 option: Read out the dynamic HART variables including the related status. ▪ Command 33 option: Read out the dynamic HART variables including the related unit. ▪ Command 48 option: Read out the complete device diagnostics. 	<ul style="list-style-type: none"> ▪ Command 1 ▪ Command 2 ▪ Command 3 ▪ Command 9 ▪ Command 33 ▪ Command 48 	Command 2

Parameter	Description	Selection / User entry	Factory setting
Burst variable 0	Assignment of the individual HART variables (PV, SV, TV, QV) and assignment of the process variables available in the device to the HART command.	<ul style="list-style-type: none"> ■ Volume flow ■ Mass flow ■ Corrected volume flow ■ Flow velocity ■ Conductivity ■ Corrected conductivity ■ Electronic temperature ■ Totalizer 1 ■ Totalizer 2 ■ Totalizer 3 ■ Density ■ Temperature ■ HART input ■ Percent Of Range ■ Measured current ■ Primary variable (PV) ■ Secondary variable (SV) ■ Tertiary variable (TV) ■ Quaternary variable (QV) ■ Not used 	Volume flow
Burst variable 1	See burst variable 0.	See burst variable 0.	Not used
Burst variable 2	See burst variable 0.	See burst variable 0.	Not used
Burst variable 3	See burst variable 0.	See burst variable 0.	Not used
Burst variable 4	See burst variable 0.	See burst variable 0.	Not used
Burst variable 5	See burst variable 0.	See burst variable 0.	Not used
Burst variable 6	See burst variable 0.	See burst variable 0.	Not used
Burst variable 7	See burst variable 0.	See burst variable 0.	Not used
Burst trigger mode	<p>Use this function to select the event that triggers burst message X.</p> <ul style="list-style-type: none"> ■ Continuous option: The message is triggered in a time-controlled manner, at least observing the time interval defined in the Burst min period parameter. ■ Window option: The message is triggered if the specified measured value has changed by the value in the Burst trigger level parameter. ■ Rising option: The message is triggered if the specified measured value exceeds the value in the Burst trigger level parameter. ■ Falling option: The message is triggered if the specified measured value drops below the value in the Burst trigger level parameter. ■ On change option: The message is triggered if the measured value changes. 	<ul style="list-style-type: none"> ■ Continuous ■ Window ■ Rising ■ Falling ■ On change 	Continuous
Burst trigger level	<p>For entering the burst trigger value.</p> <p>Together with the option selected in the Burst trigger mode parameter the burst trigger value determines the time of burst message X.</p>	Positive floating-point number	2.0E-38
Min. update period	Use this function to enter the minimum time span between two burst commands of burst message X.	Positive integer	1 000 ms
Max. update period	Use this function to enter the maximum time span between two burst commands of burst message X.	Positive integer	2 000 ms

10 Commissioning

10.1 Function check

Before commissioning the device, make sure that the post-installation and post-connection checks have been performed.

- "Post-installation check" checklist (→  25)
- "Post-connection check" checklist (→  33)

10.2 Configuring the measuring device

The **Setup** menu with its submenus contains all the parameters needed for standard operation.

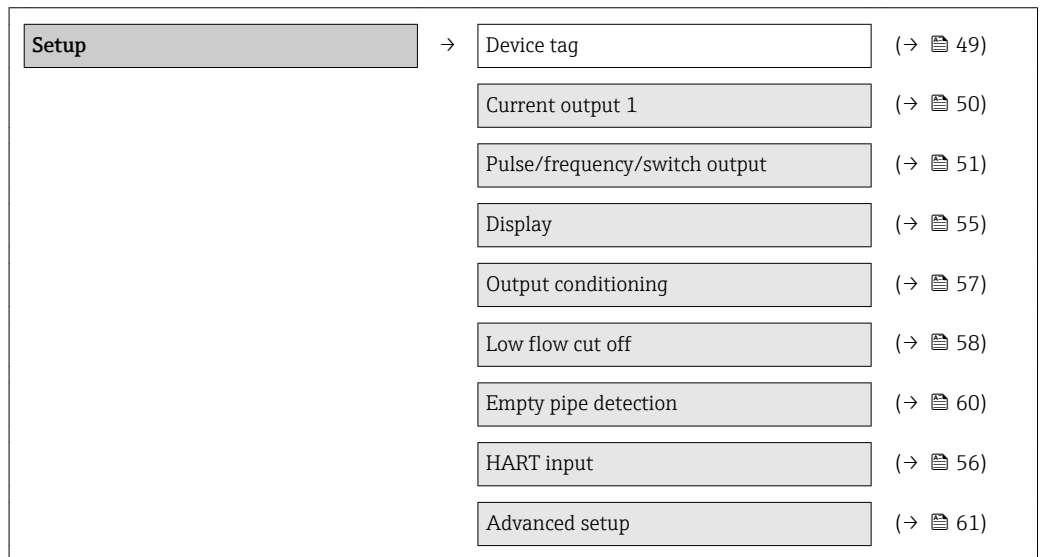

Structure of the "Setup" menu



10.2.1 Defining the tag name

To enable fast identification of the measuring point within the system, you can enter a unique designation using the **Device tag** parameter and thus change the factory setting.

 The number of characters displayed depends on the characters used.

 For information on the tag name in the "FieldCare" operating tool (→  43)

Navigation

"Setup" menu → Device tag

Parameter overview with brief description

Parameter	Description	User entry	Factory setting
Device tag	Enter tag for measuring point.	Max. 32 characters, such as letters, numbers or special characters (e.g. @, %, /).	Promag

10.2.2 Configuring the current output

The "**Current output 2**" submenu contains all the parameters that must be configured for the configuration of the current output.

Navigation

"Setup" menu → Current output 1 to 2

Structure of the submenu

Current output 1 to 2	→	Assign current output
		Current span
		4 mA value
		20 mA value
		Failure mode
		Failure current

Parameter overview with brief description

Parameter	Description	Selection / User entry	Factory setting
Assign current output	Select process variable for current output.	<ul style="list-style-type: none"> ■ Off ■ Volume flow ■ Mass flow ■ Corrected volume flow ■ Flow velocity ■ Conductivity ■ Corrected conductivity ■ Temperature ■ Electronic temperature 	Volume flow
Mass flow unit	Select mass flow unit. <i>Result</i> The selected unit applies for: <ul style="list-style-type: none"> ■ Output ■ Low flow cut off ■ Simulation process variable 	Unit choose list	Country-specific: <ul style="list-style-type: none"> ■ kg/h ■ lb/min
Volume flow unit	Select volume flow unit. <i>Result</i> The selected unit applies for: <ul style="list-style-type: none"> ■ Output ■ Low flow cut off ■ Simulation process variable 	Unit choose list	Country-specific: <ul style="list-style-type: none"> ■ l/h ■ gal/min (us)
Current span	Select current range for process value output and upper/lower level for alarm signal.	<ul style="list-style-type: none"> ■ 4...20 mA NAMUR ■ 4...20 mA US ■ 4...20 mA ■ 0...20 mA ■ Fixed current 	4...20 mA NAMUR
0/4 mA value	Enter 4 mA value.	Signed floating-point number	0 l/h
20 mA value	Enter 20 mA value.	Signed floating-point number	0.025 l/h

Parameter	Description	Selection / User entry	Factory setting
Failure mode	Define output behavior in alarm condition.	<ul style="list-style-type: none"> ■ Min. ■ Max. ■ Last valid value ■ Actual value ■ Defined value 	Max.
Failure current	Enter current output value in alarm condition.	3.59 ⁻³ to 22.5 ⁻³ mA	22.5 mA

10.2.3 Configuring the pulse/frequency/switch output

The **Pulse/frequency/switch output 1** submenu contains all the parameters that must be configured for the configuration of the selected output type.

Pulse output

Navigation

"Setup" menu → Pulse/frequency/switch output

Structure of the submenu for the pulse output

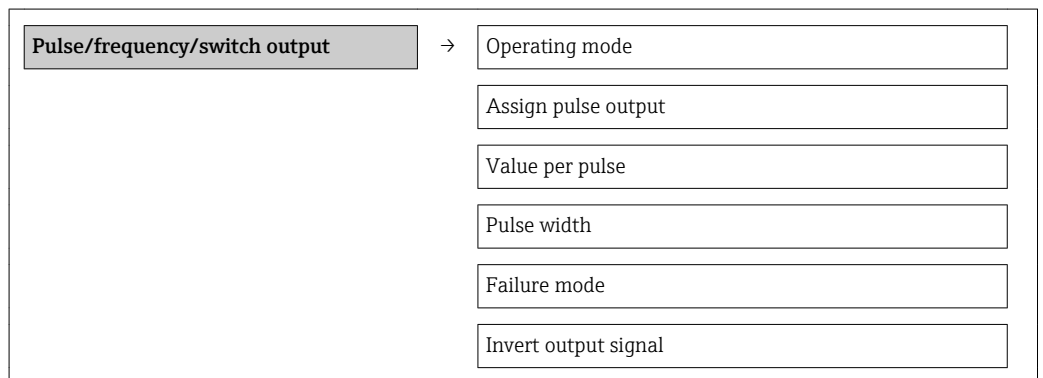

Parameter overview with brief description

Parameter	Description	Selection / User entry	Factory setting
Operating mode	Define the output as a pulse, frequency or switch output.	<ul style="list-style-type: none"> ■ Pulse ■ Frequency ■ Switch 	Pulse
Assign pulse output	Select process variable for pulse output.	<ul style="list-style-type: none"> ■ Off ■ Volume flow ■ Mass flow ■ Corrected volume flow 	Off
Mass unit	Select mass unit. <i>Result</i> The selected unit is taken from: Mass flow unit parameter	Unit choose list	Country-specific: <ul style="list-style-type: none"> ■ kg ■ lb
Volume unit	Select volume unit. Result The selected unit is taken from: Volume flow unit parameter	Unit choose list	Country-specific: <ul style="list-style-type: none"> ■ l ■ gal (us)
Value per pulse	Enter measured value at which a pulse is output.	Signed floating-point number	0
Pulse width	Define time width of the output pulse.	0.05 to 2 000 ms	100 ms

Parameter	Description	Selection / User entry	Factory setting
Failure mode	Define output behavior in alarm condition.	<ul style="list-style-type: none"> ■ Actual value ■ No pulses 	No pulses
Invert output signal	Invert the output signal.	<ul style="list-style-type: none"> ■ No ■ Yes 	No

Frequency output

Navigation

"Setup" menu → Pulse/frequency/switch output

Structure of the submenu for the frequency output

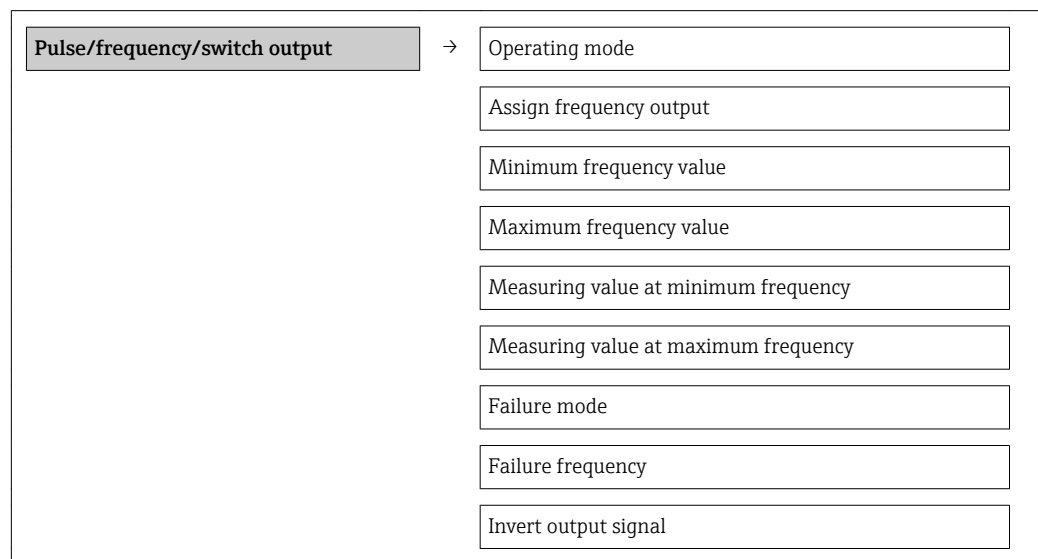

Parameter overview with brief description

Parameter	Description	Selection / User entry	Factory setting
Operating mode	Define the output as a pulse, frequency or switch output.	<ul style="list-style-type: none"> ■ Pulse ■ Frequency ■ Switch 	Pulse
Assign frequency output	Select process variable for frequency output.	<ul style="list-style-type: none"> ■ Off ■ Volume flow ■ Mass flow ■ Corrected volume flow ■ Flow velocity ■ Conductivity ■ Corrected conductivity ■ Temperature ■ Electronic temperature 	Off
Mass flow unit	Select mass flow unit. <i>Result</i> The selected unit applies for: <ul style="list-style-type: none"> ■ Output ■ Low flow cut off ■ Simulation process variable 	Unit choose list	Country-specific: <ul style="list-style-type: none"> ■ kg/h ■ lb/min

Parameter	Description	Selection / User entry	Factory setting
Volume flow unit	Select volume flow unit. <i>Result</i> The selected unit applies for: <ul style="list-style-type: none"> ■ Output ■ Low flow cut off ■ Simulation process variable 	Unit choose list	Country-specific: <ul style="list-style-type: none"> ■ l/h ■ gal/min (us)
Minimum frequency value	Enter minimum frequency.	0.0 to 10 000.0 Hz	0.0 Hz
Maximum frequency value	Enter maximum frequency.	0.0 to 10 000.0 Hz	10 000.0 Hz
Measuring value at minimum frequency	Enter measured value for minimum frequency.	Signed floating-point number	0
Measuring value at maximum frequency	Enter measured value for maximum frequency.	Signed floating-point number	0
Failure mode	Define output behavior in alarm condition.	<ul style="list-style-type: none"> ■ Actual value ■ Defined value ■ 0 Hz 	0 Hz
Failure frequency	Enter frequency output value in alarm condition.	0.0 to 12 500.0 Hz	0.0 Hz
Invert output signal	Invert the output signal.	<ul style="list-style-type: none"> ■ No ■ Yes 	No

Switch output

Navigation

"Setup" menu → Pulse/frequency/switch output

Structure of the submenu for the switch output

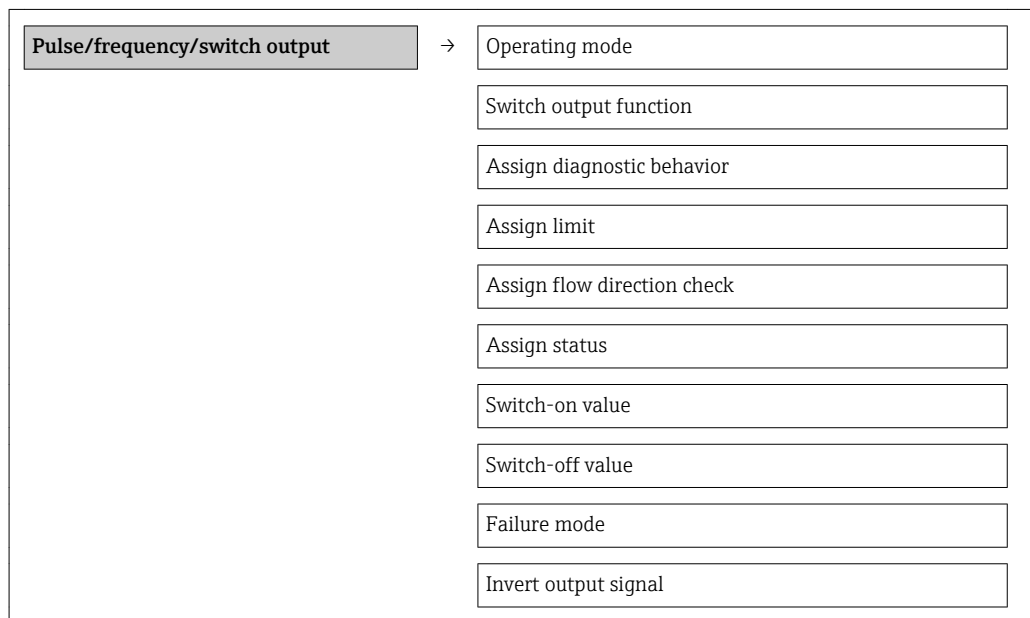

Parameter overview with brief description

Parameter	Description	Selection / User entry	Factory setting
Operating mode	Define the output as a pulse, frequency or switch output.	<ul style="list-style-type: none"> ■ Pulse ■ Frequency ■ Switch 	Pulse
Switch output function	Select function for switch output.	<ul style="list-style-type: none"> ■ Off ■ On ■ Diagnostic behavior ■ Limit ■ Flow direction check ■ Status 	Off
Assign diagnostic behavior	Select diagnostic behavior for switch output.	<ul style="list-style-type: none"> ■ Alarm ■ Alarm or warning ■ Warning 	Alarm
Assign limit	Select process variable for limit function.	<ul style="list-style-type: none"> ■ Off ■ Volume flow ■ Mass flow ■ Corrected volume flow ■ Flow velocity ■ Conductivity ■ Corrected conductivity ■ Totalizer 1 ■ Totalizer 2 ■ Totalizer 3 ■ Temperature ■ Electronic temperature 	Volume flow
Assign flow direction check	Select process variable for flow direction monitoring.	<ul style="list-style-type: none"> ■ Off ■ Volume flow ■ Mass flow ■ Corrected volume flow 	Volume flow
Assign status	Select device status for switch output.	<ul style="list-style-type: none"> ■ Empty pipe detection ■ Low flow cut off 	Empty pipe detection
Mass flow unit	Select mass flow unit. <i>Result</i> The selected unit applies for: <ul style="list-style-type: none"> ■ Output ■ Low flow cut off ■ Simulation process variable 	Unit choose list	Country-specific: <ul style="list-style-type: none"> ■ kg/h ■ lb/min
Volume flow unit	Select volume flow unit. <i>Result</i> The selected unit applies for: <ul style="list-style-type: none"> ■ Output ■ Low flow cut off ■ Simulation process variable 	Unit choose list	Country-specific: <ul style="list-style-type: none"> ■ l/h ■ gal/min (us)
Unit totalizer	Select process variable totalizer unit.	Unit choose list	1
Switch-on value	Enter measured value for the switch-on point.	Signed floating-point number	0 l/h
Switch-off value	Enter measured value for the switch-off point.	Signed floating-point number	0 l/h
Switch-on delay	Define delay for the switch-on of status output.	0.0 to 100.0 s	0.0 s
Switch-off delay	Define delay for the switch-off of status output.	0.0 to 100.0 s	0.0 s
Failure mode	Define output behavior in alarm condition.	<ul style="list-style-type: none"> ■ Actual status ■ Open ■ Closed 	Open
Invert output signal	Invert the output signal.	<ul style="list-style-type: none"> ■ No ■ Yes 	No

10.2.4 Configuring the local display

The **Display** wizard guides you systematically through all the parameters that can be configured for configuring the local display.

Navigation

"Setup" menu → Display

Structure of the wizard

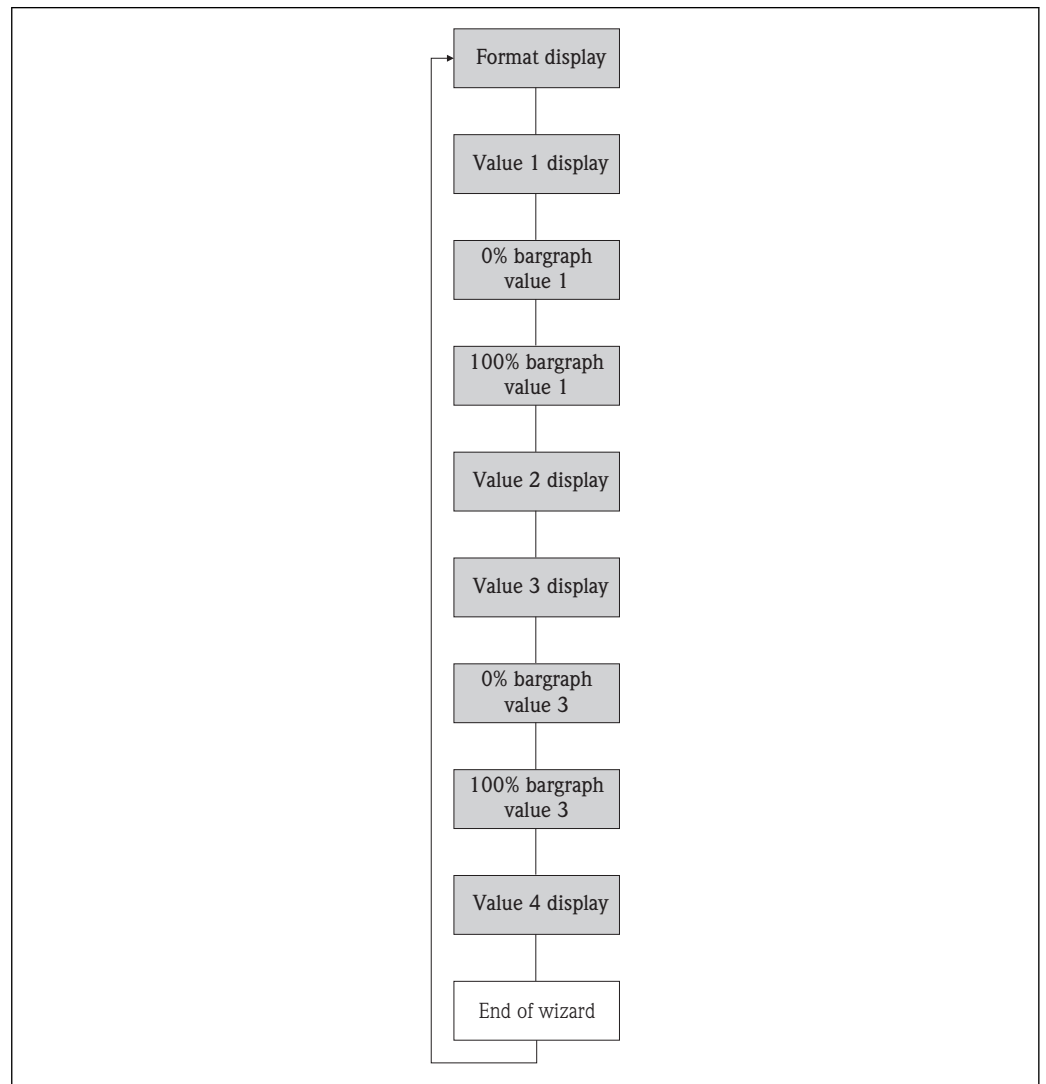

14 "Display" wizard in the "Setup" menu

A0013797-EN

Parameter overview with brief description

Parameter	Description	Selection / User entry	Factory setting
Format display	Select how measured values are shown on the display.	<ul style="list-style-type: none"> ▪ 1 value, max. size ▪ 1 bargraph + 1 value ▪ 2 values ▪ 1 value large + 2 values ▪ 4 values 	1 value, max. size
Value 1 display	Select the measured value that is shown on the local display.	<ul style="list-style-type: none"> ▪ Volume flow ▪ Mass flow ▪ Corrected volume flow ▪ Flow velocity ▪ Conductivity ▪ Corrected conductivity ▪ Temperature ▪ Electronic temperature ▪ Totalizer 1 ▪ Totalizer 2 ▪ Totalizer 3 ▪ Current output 1 ▪ None 	Volume flow
0% bargraph value 1	Enter 0% value for bar graph display.	Signed floating-point number	0 l/h
100% bargraph value 1	Enter 100% value for bar graph display.	Signed floating-point number	0.025 l/h
Value 2 display	Select the measured value that is shown on the local display.	Picklist (see 1st display value)	None
Value 3 display	Select the measured value that is shown on the local display.	Picklist (see 1st display value)	None
0% bargraph value 3	Enter 0% value for bar graph display.	Signed floating-point number	0
100% bargraph value 3	Enter 100% value for bar graph display.	Signed floating-point number	0
Value 4 display	Select the measured value that is shown on the local display.	Picklist (see 1st display value)	None

10.2.5 Configuring the HART input

The **HART input** submenu contains all the parameters that must be configured for the configuration of the HART input.

Navigation

"Expert" menu → Communication → HART input → Configuration

HART input	→	Capture mode
		Device ID
		Device type
		Manufacturer ID
		Burst command
		Slot number
		Timeout
		Failure mode
		Failure value

Parameter overview with brief description

Parameter	Description	Selection / User entry	Factory setting
Capture mode	Select capture mode via burst or master communication.	<ul style="list-style-type: none"> ▪ Off ▪ Burst network ▪ Master network 	Off
Manufacturer ID	Enter manufacture ID of external device.	0 to 255	0
Device ID	Enter device ID of external device.	Positive integer	0
Device type	Enter device type of external device.	0 to 255	0
Burst command	Select command to read in external process variable.	<ul style="list-style-type: none"> ▪ Command 1 ▪ Command 3 ▪ Command 9 ▪ Command 33 	Command 1
Slot number	Define position of external process variable in burst command.	1 to 4	1
Timeout	Enter deadline for process variable of external device.  If the deadline is exceeded, diagnostic message F410 data transmission is output.	1 to 120 s	5 s
Failure mode	Define behavior if external process variable is missed.	<ul style="list-style-type: none"> ▪ Alarm ▪ Last valid value ▪ Defined value 	Alarm
Failure value	Enter value to be used by the device if input value from external device is missing.	Signed floating-point number	0

10.2.6 Configuring the output conditioning

The **Output conditioning** wizard contains all the parameters that must be configured for the configuration of output conditioning.

Navigation

"Setup" menu → Output conditioning

Structure of the submenu for output conditioning

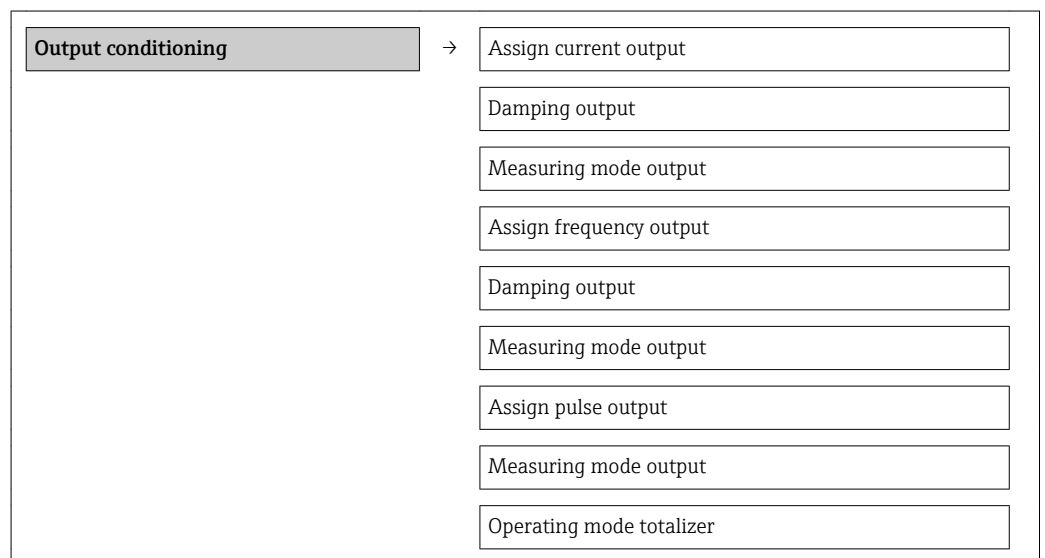

Parameter overview with brief description

Parameter	Description	Selection / User entry	Factory setting
Assign current output	Select process variable for current output.	<ul style="list-style-type: none"> ■ Off ■ Volume flow ■ Mass flow ■ Corrected volume flow ■ Flow velocity ■ Conductivity ■ Corrected conductivity ■ Temperature ■ Electronic temperature 	Volume flow
Damping output 1	Set reaction time for output signal to fluctuations in the measured value.	0 to 999.9 s	1 s
Measuring mode output 1	Select measuring mode for output.	<ul style="list-style-type: none"> ■ Forward flow ■ Forward/Reverse flow ■ Reverse flow compensation 	Forward flow
Assign frequency output	Select process variable for frequency output.	<ul style="list-style-type: none"> ■ Off ■ Volume flow ■ Mass flow ■ Corrected volume flow ■ Flow velocity ■ Conductivity ■ Corrected conductivity ■ Temperature ■ Electronic temperature 	Off
Damping output 1	Set reaction time for output signal to fluctuations in the measured value.	0 to 999.9 s	1 s
Measuring mode output 1	Select measuring mode for output.	<ul style="list-style-type: none"> ■ Forward flow ■ Forward/Reverse flow ■ Reverse flow ■ Reverse flow compensation 	Forward flow
Assign pulse output	Select process variable for pulse output.	<ul style="list-style-type: none"> ■ Off ■ Volume flow ■ Mass flow ■ Corrected volume flow 	Off
Measuring mode output 1	Select measuring mode for output.	<ul style="list-style-type: none"> ■ Forward flow ■ Forward/Reverse flow ■ Reverse flow ■ Reverse flow compensation 	Forward flow
Operating mode totalizer #	Select totalizer calculation mode.	<ul style="list-style-type: none"> ■ Net flow total ■ Forward flow total ■ Reverse flow total 	Net flow total

10.2.7 Configuring the low flow cut off

The **Low flow cut off** submenu contains parameters that must be configured for the configuration of low flow cut off.

Navigation

"Setup" menu → Low flow cut off

Structure of the submenu

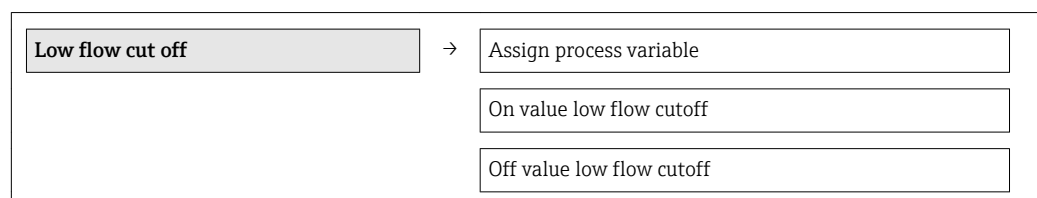

	Pressure shock suppression
--	----------------------------

Parameter overview with brief description

Parameter	Prerequisite	Description	Selection / User entry	Factory setting
Assign process variable	–	Select process variable for low flow cut off.	<ul style="list-style-type: none"> ■ Off ■ Volume flow ■ Mass flow ■ Corrected volume flow 	Volume flow
On value low flow cutoff	One of the following options is selected in the Assign process variable parameter: <ul style="list-style-type: none"> ■ Mass flow ■ Volume flow ■ Corrected volume flow 	Enter on value for low flow cut off.	Signed floating-point number	For liquids: depends on country and nominal diameter
Off value low flow cutoff	One of the following options is selected in the Assign process variable parameter: <ul style="list-style-type: none"> ■ Mass flow ■ Volume flow ■ Corrected volume flow 	Enter off value for low flow cut off.	0 to 100.0 %	50 %
Pressure shock suppression	One of the following options is selected in the Assign process variable parameter: <ul style="list-style-type: none"> ■ Mass flow ■ Volume flow ■ Corrected volume flow 	Enter time frame for signal suppression (= active pressure shock suppression).	0 to 100 s	0 s

10.2.8 Configuring empty pipe detection

The **Empty pipe detection** submenu contains parameters that must be configured for the configuration of low flow cut off.

Navigation

"Setup" menu → Empty pipe detection

Structure of the submenu

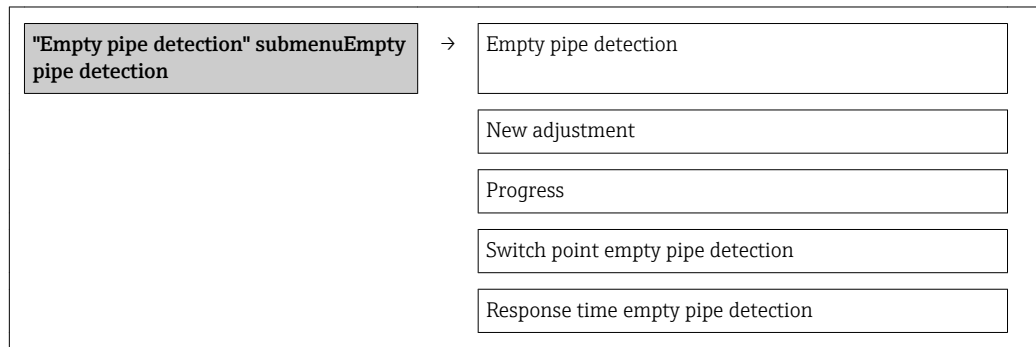

Parameter overview with brief description

Parameter	Prerequisite	Description	Selection / User interface / User entry	Factory setting
Empty pipe detection	-	Switch empty pipe detection on and off.	<ul style="list-style-type: none"> ▪ Off ▪ On 	Off
New adjustment	-	Select type of adjustment.	<ul style="list-style-type: none"> ▪ Cancel ▪ Empty pipe adjust ▪ Full pipe adjust 	Cancel
Progress	-		<ul style="list-style-type: none"> ▪ Ok ▪ Busy ▪ Not ok 	-
Switch point empty pipe detection	-	Enter hysteresis in %, below this value the measuring tube will be detected as empty.	0 to 100 %	10 %
Response time empty pipe detection	One of the following options is selected in the Assign process variable parameter: <ul style="list-style-type: none"> ▪ Density ▪ Reference density 	Enter the time before diagnostic message S862 'Pipe empty' is displayed for empty pipe detection.	0 to 100 s	1 s

10.3 Advanced settings

The **Advanced setup** submenu with its submenus contains parameters for specific settings.

Overview of the parameters and submenus in the "Advanced setup" submenu

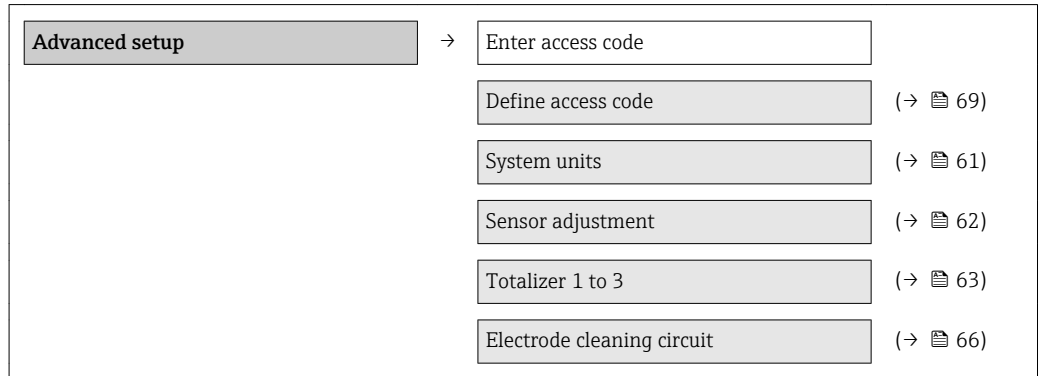

10.3.1 Setting the system units

In the **System units** submenu the units of all the measured values can be set.

Navigation

"Setup" menu → System units

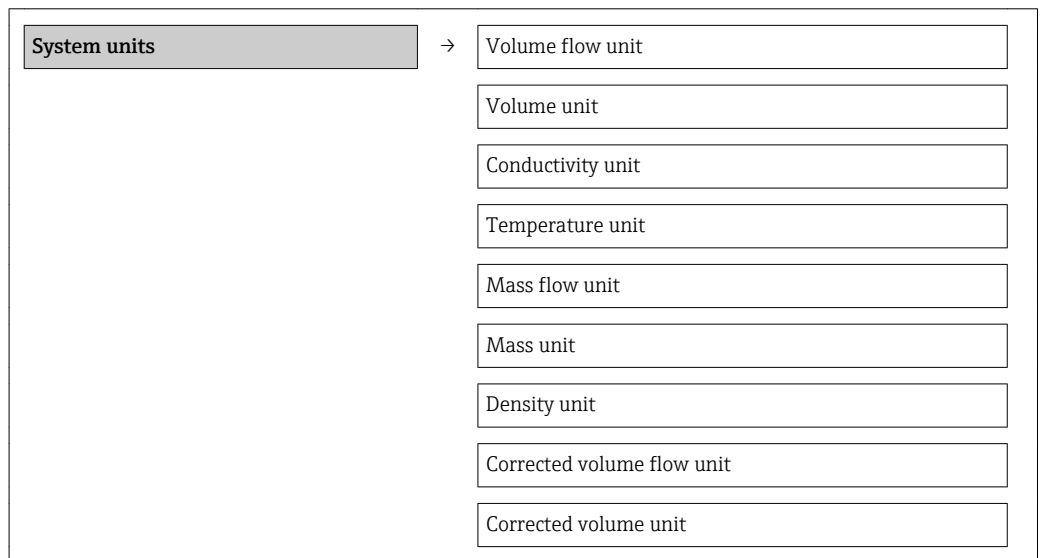

Parameter overview with brief description

Parameter	Description	Selection	Factory setting
Volume flow unit	Select volume flow unit. <i>Result</i> The selected unit applies for: <ul style="list-style-type: none"> ▪ Output ▪ Low flow cut off ▪ Simulation process variable 	Unit choose list	Country-specific: <ul style="list-style-type: none"> ▪ l/h ▪ gal/min (us)
Volume unit	Select volume unit. Result The selected unit is taken from: Volume flow unit parameter	Unit choose list	Country-specific: <ul style="list-style-type: none"> ▪ l ▪ gal (us)

Parameter	Description	Selection	Factory setting
Conductivity unit	Select conductivity unit. <i>Result</i> The selected unit applies for: <ul style="list-style-type: none"> ▪ Current output ▪ Frequency output ▪ Switch output ▪ Simulation process variable 	Unit choose list	µS/cm
Temperature unit	Select temperature unit. <i>Result</i> The selected unit applies for: <ul style="list-style-type: none"> ▪ Output ▪ Reference temperature ▪ Simulation process variable 	Unit choose list	Country-specific: <ul style="list-style-type: none"> ▪ °C (Celsius) ▪ °F (Fahrenheit)
Mass flow unit	Select mass flow unit. <i>Result</i> The selected unit applies for: <ul style="list-style-type: none"> ▪ Output ▪ Low flow cut off ▪ Simulation process variable 	Unit choose list	Country-specific: <ul style="list-style-type: none"> ▪ kg/h ▪ lb/min
Mass unit	Select mass unit. <i>Result</i> The selected unit is taken from: Mass flow unit parameter	Unit choose list	Country-specific: <ul style="list-style-type: none"> ▪ kg ▪ lb
Density unit	Select density unit. <i>Result</i> The selected unit applies for: <ul style="list-style-type: none"> ▪ Output ▪ Simulation process variable ▪ Density adjustment (in Expert menu) 	Unit choose list	Country-specific: <ul style="list-style-type: none"> ▪ kg/l ▪ lb/ft³
Corrected volume flow unit	Select corrected volume flow unit. <i>Result</i> The selected unit applies for: <ul style="list-style-type: none"> ▪ Output ▪ Low flow cut off ▪ Simulation process variable 	Unit choose list	Country-specific: <ul style="list-style-type: none"> ▪ NI/h ▪ Sft³/h
Corrected volume unit	Select corrected volume unit. Result The selected unit is taken from: Corrected volume flow unit parameter	Unit choose list	Country-specific: <ul style="list-style-type: none"> ▪ NI ▪ Sft³

10.3.2 Carrying out a sensor adjustment

The **Sensor adjustment** submenu contains parameters that pertain to the functionality of the sensor.

Navigation

"Setup" menu → Advanced setup → Sensor adjustment

Structure of the submenu



Parameter overview with brief description

Parameter	Description	Selection	Factory setting
Installation direction	Set sign of flow direction to match the direction of the arrow on the sensor.	<ul style="list-style-type: none"> ▪ Flow in arrow direction ▪ Flow against arrow direction 	Flow in arrow direction

10.3.3 Configuring the totalizer

In the "**Totalizer 1 to 3**" submenu the individual totalizers can be configured.

Navigation

"Setup" menu → Advanced setup → Totalizer 1 to 3

Totalizer 1 to 3	→	Assign process variable
		Unit totalizer
		Failure mode

Parameter overview with brief description

Parameter	Description	Selection	Factory setting
Assign process variable	Select process variable for totalizer.	<ul style="list-style-type: none"> ▪ Off ▪ Volume flow ▪ Mass flow ▪ Corrected volume flow 	Volume flow
Unit totalizer	Select process variable totalizer unit.	Unit choose list	1
Totalizer operation mode	Select totalizer calculation mode.	<ul style="list-style-type: none"> ▪ Net flow total ▪ Forward flow total ▪ Reverse flow total 	Net flow total
Failure mode	Define totalizer behavior in alarm condition.	<ul style="list-style-type: none"> ▪ Stop ▪ Actual value ▪ Last valid value 	Stop

10.3.4 Carrying out additional display configurations

In the **"Display"** submenu you can set all the parameters involved in the configuration of the local display.

Navigation

"Setup" menu → Advanced setup → Display

Structure of the submenu

Display	→	Format display
		Value 1 display
		0% bargraph value 1
		100% bargraph value 1
		Decimal places 1
		Value 2 display
		Decimal places 2
		Value 3 display
		0% bargraph value 3
		100% bargraph value 3
		Decimal places 3
		Value 4 display
		Decimal places 4
		Display language
		Display interval
		Display damping
		Header
		Header text
		Separator
		Backlight

Parameter overview with brief description

Parameter	Description	Selection / User entry	Factory setting
Format display	Select how measured values are shown on the display.	<ul style="list-style-type: none"> ■ 1 value, max. size ■ 1 bargraph + 1 value ■ 2 values ■ 1 value large + 2 values ■ 4 values 	1 value, max. size
Value 1 display	Select the measured value that is shown on the local display.	<ul style="list-style-type: none"> ■ Volume flow ■ Mass flow ■ Corrected volume flow ■ Flow velocity ■ Conductivity ■ Corrected conductivity ■ Temperature ■ Electronic temperature ■ Totalizer 1 ■ Totalizer 2 ■ Totalizer 3 ■ Current output 1 ■ None 	Volume flow
0% bargraph value 1	Enter 0% value for bar graph display.	Signed floating-point number	0 l/h
100% bargraph value 1	Enter 100% value for bar graph display.	Signed floating-point number	0.025 l/h
Decimal places 1	Select the number of decimal places for the display value.	<ul style="list-style-type: none"> ■ x ■ x.x ■ x.xx ■ x.xxx ■ x.xxxx 	x.xx
Value 2 display	Select the measured value that is shown on the local display.	Picklist (see 1st display value)	None
Decimal places 2	Select the number of decimal places for the display value.	<ul style="list-style-type: none"> ■ x ■ x.x ■ x.xx ■ x.xxx ■ x.xxxx 	x.xx
Value 3 display	Select the measured value that is shown on the local display.	Picklist (see 1st display value)	None
0% bargraph value 3	Enter 0% value for bar graph display.	Signed floating-point number	0
100% bargraph value 3	Enter 100% value for bar graph display.	Signed floating-point number	0
Decimal places 3	Select the number of decimal places for the display value.	<ul style="list-style-type: none"> ■ x ■ x.x ■ x.xx ■ x.xxx ■ x.xxxx 	x.xx
Value 4 display	Select the measured value that is shown on the local display.	Picklist (see 1st display value)	None
Decimal places 4	Select the number of decimal places for the display value.	<ul style="list-style-type: none"> ■ x ■ x.x ■ x.xx ■ x.xxx ■ x.xxxx 	x.xx

Parameter	Description	Selection / User entry	Factory setting
Display language	Set display language.	<ul style="list-style-type: none"> ▪ English ▪ Deutsch ▪ Français ▪ Español ▪ Italiano ▪ Nederlands ▪ Portuguesa ▪ Polski ▪ русский язык (Russian) ▪ Svenska ▪ Türkçe ▪ 中文 (Chinese) ▪ 日本語 (Japanese) ▪ 한국어 (Korean) ▪ العربية (Arabic) ▪ Bahasa Indonesia ▪ ภาษาไทย (Thai) ▪ tiếng Việt (Vietnamese) ▪ čeština (Czech) 	English (alternatively, the ordered language is preset in the device)
Display interval	Set time measured values are shown on display if display alternates between values.	1 to 10 s	5 s
Display damping	Set display reaction time to fluctuations in the measured value.	0.0 to 999.9 s	0.0 s
Header	Select header contents on local display.	<ul style="list-style-type: none"> ▪ Device tag ▪ Free text 	Device tag
Header text	Enter display header text.		-----
Separator	Select decimal separator for displaying numerical values.	<ul style="list-style-type: none"> ▪ . ▪ , 	.
Backlight	Switch the local display backlight on and off.	<ul style="list-style-type: none"> ▪ Disable ▪ Enable 	Enable

10.3.5 Performing electrode cleaning

The **Electrode cleaning circuit** submenu contains parameters that must be configured for the configuration of electrode cleaning.

 The submenu is only available if the device was ordered with electrode cleaning.

Navigation

"Setup" menu → Advanced setup → Electrode cleaning circuit

Structure of the submenu

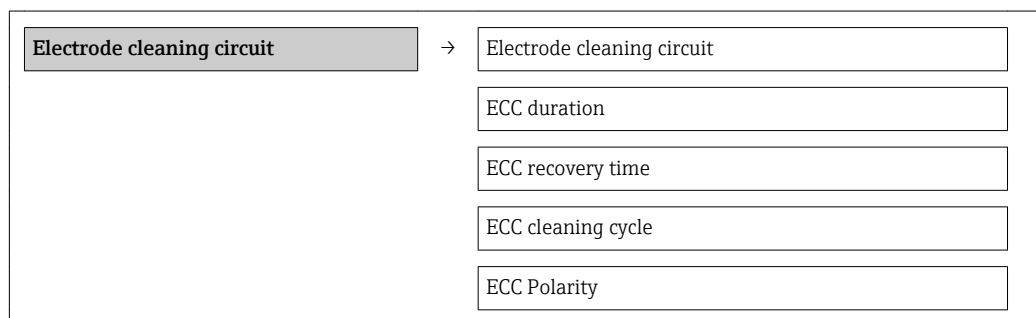

Parameter overview with brief description

Parameter	Description	Selection / User entry / User interface	Factory setting
Electrode cleaning circuit	Enable the cyclic electrode cleaning circuit.	<ul style="list-style-type: none"> ■ Off ■ On 	Off
ECC duration	Enter the duration of electrode cleaning in seconds.	0.01 to 30 s	2 s
ECC recovery time	Define recovery time after electrode cleaning. During this time the current output values will be held at last valid value.	1 to 3.0 ⁺³⁸ s	60 s
ECC cleaning cycle	Enter the pause duration between electrode cleaning cycles.	0.5 to 168 h	0.5 h
ECC Polarity	Select the polarity of the electrode cleaning circuit.	<ul style="list-style-type: none"> ■ Positive ■ Negative 	Positive

10.4 Simulation

The **"Simulation"** submenu enables you to simulate, without a real flow situation, various process variables in the process and the device alarm mode and to verify downstream signal chains (switching valves or closed-control loops).

Navigation

"Diagnostics" menu → Simulation

Simulation

→

Assign simulation process variable

Value process variable

Simulation current output

Value current output

Frequency simulation

Frequency value

Pulse simulation

Pulse value

Switch output simulation

Switch status

Simulation device alarm



Simulation diagnostic event

Parameter overview with brief description

Parameter	Prerequisite	Description	Selection / User entry	Factory setting
Assign simulation process variable	–	Select a process variable for the simulation process that is activated.	<ul style="list-style-type: none"> ▪ Off ▪ Volume flow ▪ Mass flow ▪ Corrected volume flow ▪ Conductivity ▪ Corrected conductivity ▪ Temperature 	Off
Value process variable	A process variable is selected in the Assign simulation process variable parameter.	Enter the simulation value for the selected process variable.	Signed floating-point number	0
Simulation current output 1	–	Switch simulation of the current output on and off.	<ul style="list-style-type: none"> ▪ Off ▪ On 	Off
Value current output 1	The On option is selected in the Current output simulation parameter.	Enter the current value for simulation.	$3.59 \cdot 10^{-3}$ to $22.5 \cdot 10^{-3}$ mA	3.59 mA
Frequency simulation 1	–	Switch simulation of the frequency output on and off.	<ul style="list-style-type: none"> ▪ Off ▪ On 	Off
Frequency value 1	The On option is selected in the Frequency output simulation parameter.	Enter the frequency value for simulation.	0.0 to 12 500.0 Hz	0.0 Hz
Pulse simulation 1	The Down-count. val. option is selected in the Simulation pulse output parameter.	Switch simulation of the pulse output on and off.  If the Fixed value option is selected, the Pulse width parameter defines the pulse width of the pulses output.	<ul style="list-style-type: none"> ▪ Off ▪ Fixed value ▪ Down-counting value 	Off
Pulse value 1	The Down-count. val. option is selected in the Simulation pulse output parameter.	Enter the number of pulses for simulation.	0 to 65 535	0
Switch output simulation 1	–	Switch simulation of switch output on and off.	<ul style="list-style-type: none"> ▪ Off ▪ On 	Off
Switch status 1	The On option is selected in the Switch output simulation parameter.	Select the status of the status output for the simulation.	<ul style="list-style-type: none"> ▪ Open ▪ Closed 	Open
Simulation device alarm	–	Switch the device alarm on and off.	<ul style="list-style-type: none"> ▪ Off ▪ On 	Off
Simulation diagnostic event	–	Switch simulation of the diagnostic event on and off. For the simulation, you can choose from the diagnostic events of the category selected in the Diagnostic event category parameter.	<ul style="list-style-type: none"> ▪ Off ▪ Picklist Diagnostic events (depends on the selected category) 	Off

10.5 Protecting settings from unauthorized access

The following options exist for protecting the configuration of the measuring device from unintentional modification after commissioning:

- Write protection via access code for Web browser (→  69)
- Write protection via write protection switch (→  69)

10.5.1 Write protection via access code

With the customer-specific access code, access to the measuring device via the Web browser is protected, as are the parameters for the measuring device configuration.

Navigation

"Setup" menu → Advanced setup → Administration → Define access code

Structure of the submenu

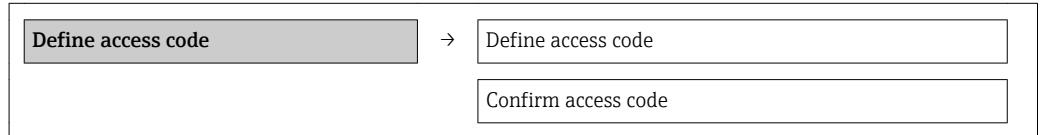

Defining the access code via the Web browser

1. Navigate to the **Enter access code** parameter.
2. Define a max. 4-digit numeric code as an access code.
3. Enter the access code again to confirm the code.
 - ↳ The Web browser switches to the login page.

 If no action is performed for 10 minutes, the Web browser automatically returns to the login page.

 The user role with which the user is currently logged on via the Web browser is indicated by the **Access status tooling** parameter. Navigation path: Operation → Access status tooling

10.5.2 Write protection via write protection switch

The write protection switch makes it possible to block write access to the entire operating menu with the exception of the following parameters:

- External pressure
- External temperature
- Reference density
- All parameters for configuring the totalizer

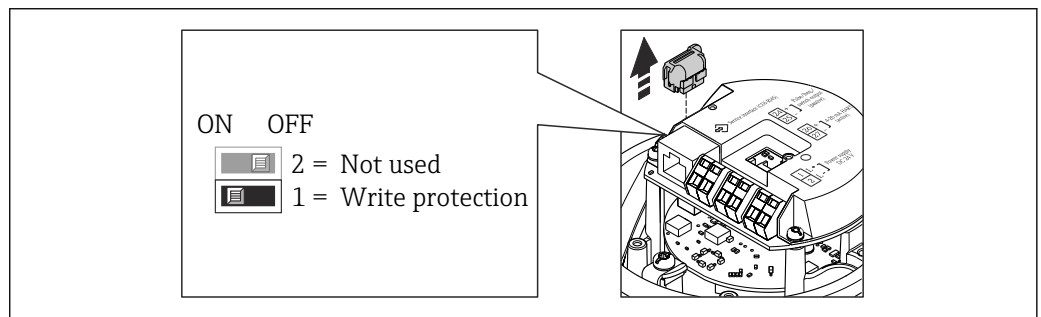

The parameter values are now read only and cannot be edited any more:

- Via service interface (CDI)
- Via HART protocol



A0022571

1. Depending on the housing version, loosen the securing clamp or fixing screw of the housing cover.
2. Depending on the housing version, unscrew or open the housing cover and disconnect the local display from the main electronics module where necessary (→  106).
3. Disconnect the T-DAT from the main electronics module.

4. Setting the write protection switch on the main electronics module to the ON position enables the hardware write protection. Setting the write protection switch on the main electronics module to the OFF position (factory setting) disables the hardware write protection.
 - ↳ If hardware write protection is enabled: the **Locking status** parameter displays the **Hardware locked** option(→  71); if disabled, the **Locking status** parameter does not display any option (→  71)
5. Reverse the removal procedure to reassemble the transmitter.

11 Operation

11.1 Reading device locking status

The write protection types that are currently active can be determined using the **Locking status** parameter.

Navigation

"Operation" menu → Locking status

Function scope of "Locking status" parameter

Options	Description
Hardware locked	The locking switch (DIPswitch) for locking the hardware is activated on the main electronic module. This prevents write access to the parameters (→ 69).
Temporarily locked	Due to internal processing in the device (e.g. up-/downloading of data, reset), write access to the parameters is blocked for a short time. Once the internal processing has been completed, the parameters can be changed once again.

11.2 Reading measured values

Using the **Measured values** submenu, it is possible to read all the measured values.

"Diagnostics" menu → Measured values

11.2.1 Process variables

The **Process variables** submenu contains all the parameters needed to display the current measured values for every process variable.

Navigation

"Diagnostics" menu → Measured values → Process variables

Structure of the submenu

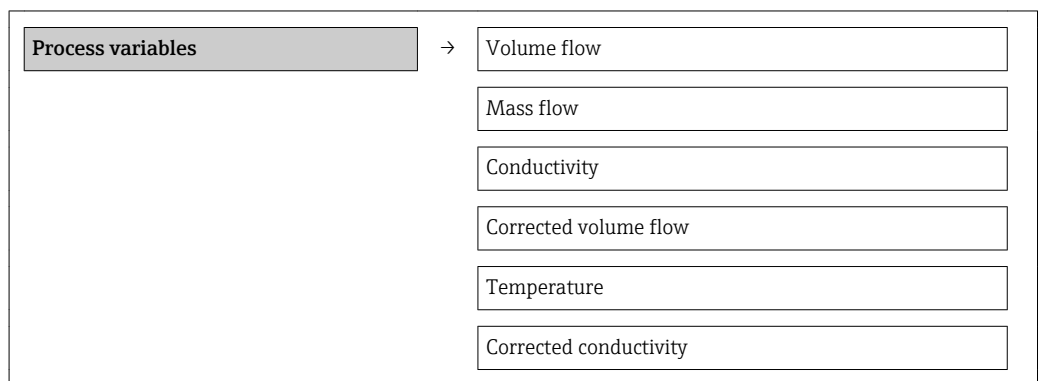

Structure of the submenu

Parameter overview with brief description

Parameter	Description	User interface
Volume flow	Displays the volume flow currently measured.	Signed floating-point number
Mass flow	Displays the mass flow currently calculated.	Signed floating-point number

Parameter	Description	User interface
Conductivity	Displays the corrected volume flow currently calculated.	Signed floating-point number
Corrected volume flow	Displays the temperature currently measured.	Signed floating-point number
Temperature	Displays the saturated steam pressure currently calculated.	Positive floating-point number
Corrected conductivity	Displays the steam quality currently calculated.	Positive floating-point number

11.2.2 Totalizer

The **"Totalizer" submenu** contains all the parameters needed to display the current measured values for every totalizer.

Navigation

"Diagnostics" menu → Measured values → Totalizer

Structure of the submenu

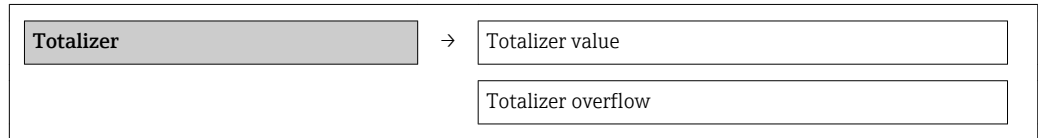

Parameter overview with brief description

Parameter	Description	User interface	Factory setting
Totalizer value 1	Displays the current totalizer counter value.	Signed floating-point number	01
Totalizer overflow 1	Displays the current totalizer overflow.	-32 000.0 to 32 000.0	0

11.2.3 Output values

The **"Output values" submenu** contains all the parameters needed to display the current measured values for every output.

Navigation

"Diagnostics" menu → Measured values → Output values

Structure of the submenu

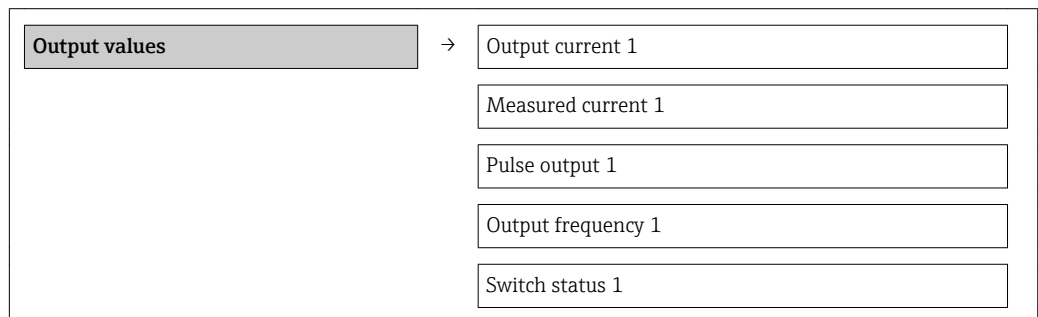



Parameter overview with brief description

Parameter	Description	User interface	Factory setting
Output current 1	Displays the current value currently calculated for the current output.	3.59 to 22.5 mA	3.59 mA
Measured current 1	Displays the current value currently measured for the current output.	0 to 30 mA	0 mA
Pulse output 1	Displays the value currently measured for the pulse output.	Positive floating-point number	0 Hz
Output frequency 1	Displays the value currently measured for the frequency output.	0.0 to 12 500.0 Hz	0.0 Hz
Switch status 1	Displays the current switch output status.	<ul style="list-style-type: none"> ▪ Open ▪ Closed 	Open

11.3 Adapting the measuring device to the process conditions

The following are available for this purpose:

- Basic settings using the **Setup** menu(→  49)
- Advanced settings using the **Advanced setup** submenu(→  61)

11.4 Performing a totalizer reset

In the **Operation** submenu the totalizers are reset:

- Control Totalizer
- Reset all totalizers

Function scope of "Control Totalizer " parameter

Options	Description
Totalize	The totalizer is started.
Stop	Totalizing is stopped.
Reset + hold	The totaling process is stopped and the totalizer is reset to 0.
Preset + hold	The totaling process is stopped and the totalizer is set to its defined start value from the Preset value parameter.
Reset + totalize	The totalizer is reset to 0 and the totaling process is restarted.
Preset + totalize	The totalizer is set to the defined start value in Preset value parameter and the totaling process is restarted.

Function scope of "Reset all totalizers" parameter

Options	Description
Reset + totalize	Resets all totalizers to 0 and restarts the totaling process. This deletes all the flow values previously totalized.

Navigation

"Operation" menu → Operation

Structure of the submenu



	Preset value
	Reset all totalizers

Parameter overview with brief description

Parameter	Description	Selection / User entry	Factory setting
Control Totalizer #	Control totalizer value.	<ul style="list-style-type: none"> ■ Totalize ■ Reset + hold ■ Preset + hold ■ Reset + totalize ■ Preset + totalize 	Totalize
Preset value #	Specify start value for totalizer.	Signed floating-point number	01
Reset all totalizers	Reset all totalizers to 0 and start.	<ul style="list-style-type: none"> ■ Cancel ■ Reset + totalize 	Cancel





12 Diagnostics and troubleshooting

12.1 General troubleshooting

For output signals

Problem	Possible causes	Remedy
Green power LED on the main electronics module of the transmitter is dark	Supply voltage does not match that specified on the nameplate.	Apply the correct supply voltage (→  29).
Device measures incorrectly.	Configuration error or device is operated outside the application.	1. Check and correct parameter configuration. 2. Observe limit values specified in the "Technical Data".

For access

Problem	Possible causes	Remedy
No write access to parameters	Hardware write protection enabled	Set the write protection switch on the main electronics module to the OFF position (→  69).
No connection via HART protocol	Missing or incorrectly installed communication resistor.	Install the communication resistor (250 Ω) correctly. Observe the maximum load (→  95).
No connection via HART protocol	Commubox <ul style="list-style-type: none"> ▪ Connected incorrectly ▪ Configured incorrectly ▪ Drivers not installed correctly ▪ USB interface on computer configured incorrectly 	Observe the documentation for the Commubox.  FXA195 HART: Document "Technical Information" TI00404F
Not connecting to Web server	Incorrect setting for the Ethernet interface of the computer	1. Check the properties of the Internet protocol (TCP/IP) (→  37). 2. Check the network settings with the IT manager.
Not connecting to Web server	Web server disabled	Via the "FieldCare" operating tool check whether the Web server of the measuring device is enabled and enable it if necessary (→  39).
No or incomplete display of contents in the Web browser	<ul style="list-style-type: none"> ▪ JavaScript not enabled ▪ JavaScript cannot be enabled 	1. Enable JavaScript. 2. Enter http://XXX.XXX.X.XXX/basic.html as the IP address.
Web browser frozen and operation no longer possible	Data transfer active	Wait until data transfer or current action is finished.
Web browser frozen and operation no longer possible	Connection lost	1. Check cable connection and power supply. 2. Refresh the Web browser and restart if necessary.
Content of Web browser incomplete or difficult to read	Not using optimum version of Web server.	1. Use the correct Web browser version (→  37). 2. Clear the Web browser cache and restart the Web browser.
Content of Web browser incomplete or difficult to read	Unsuitable view settings.	Change the font size/display ratio of the Web browser.

12.2 Diagnostic information via light emitting diodes

12.2.1 Transmitter

Various light emitting diodes (LEDs) on the main electronics module of the transmitter provide information on device status.

LED	Color	Meaning
Power	Off	Supply voltage is off or too low
	Green	Supply voltage is ok
Link/Activity	Orange	Link available but no activity
	Flashing orange	Activity present
Communication	Flashing white	HART communication is active.

12.3 Diagnostic information in FieldCare

12.3.1 Diagnostic options

Any faults detected by the measuring device are displayed on the home page of the operating tool once the connection has been established.

The screenshot shows the FieldCare software interface. At the top, there is a status bar with the following information:

- Device name: Xxxxxxx
- Device tag: Xxxxxxx
- Status signal: Function check (C)
- Mass flow: 12.34 kg/h
- Volume flow: 12.34 m³/h

Below the status bar is a tree view of the device structure:

- Xxxxxxx
 - Diagnostics 1: C485 Simu...
 - Remedy information: Deactivate...
 - Access status tooling: Maintenance
 - Operation
 - Setup
 - Diagnostics
 - Expert

The main panel is titled "Instrument health status" and displays the following fault categories:

- Failure (F)
- Function check (C)
 - Diagnostics 1: C485 Simulation measured vari...
 - Remedy information: Deactivate Simulation (Service...
- Out of specification (S)
- Maintenance required (M)

Annotations in the image point to:

- 1: Status area with status signal
- 2: Diagnostic information (→ 77)
- 3: Remedial measures with Service ID





- 1 Status area with status signal
- 2 Diagnostic information (→ 77)
- 3 Remedial measures with Service ID

i Furthermore, diagnostic events that have occurred can be viewed in the **Diagnostics** menu:

- Via parameters (→ 81)
- Via submenu (→ 82)

Status signals

The status signals provide information on the state and reliability of the device by categorizing the cause of the diagnostic information (diagnostic event).

Symbol	Meaning
 A0017271	Failure A device error has occurred. The measured value is no longer valid.
 A0017278	Function check The device is in service mode (e.g. during a simulation).
 A0017277	Out of specification The device is operated: <ul style="list-style-type: none"> ▪ Outside its technical specification limits (e.g. outside the process temperature range) ▪ Outside of the configuration carried out by the user (e.g. maximum flow in parameter 20 mA value)
 A0017276	Maintenance required Maintenance is required. The measured value is still valid.

 The status signals are categorized in accordance with VDI/VDE 2650 and NAMUR Recommendation NE 107.

Diagnostic information

The fault can be identified using the diagnostic information. The short text helps you by providing information about the fault.

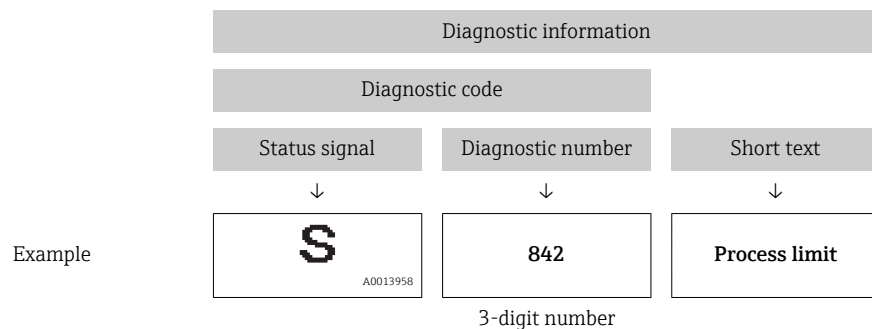

12.3.2 Calling up remedy information

Remedy information is provided for every diagnostic event to ensure that problems can be rectified quickly:

- On the home page
Remedy information is displayed in a separate field below the diagnostics information.
- In the **Diagnostics** menu
Remedy information can be called up in the working area of the user interface.

The user is in the **Diagnostics** menu.

1. Call up the desired parameter.
2. On the right in the working area, mouse over the parameter.
↳ A tool tip with remedy information for the diagnostic event appears.

12.4 Adapting the diagnostic information

12.4.1 Adapting the diagnostic behavior

Each item of diagnostic information is assigned a specific diagnostic behavior at the factory. The user can change this assignment for certain diagnostics information in the **Diagnostic behavior** submenu .

"Expert" menu → System → Diagnostic handling → Diagnostic behavior

You can assign the following options to the diagnostic number as the diagnostic behavior:

Options	Description
Alarm	Measurement is interrupted. Signal outputs and totalizers assume the defined alarm condition. A diagnostic message is generated.
Warning	Measurement is resumed. The signal outputs and totalizers are not affected. A diagnostic message is generated.
Logbook entry only	The device continues to measure. The diagnostic message is entered in the Event logbook (events list) submenu only and is not displayed in alternation with the measured value display.
Off	The diagnostic event is ignored, and no diagnostic message is generated or entered.

12.4.2 Adapting the status signal

Each item of diagnostic information is assigned a specific status signal at the factory. The user can change this assignment for certain diagnostic information in the **Diagnostic event category** submenu .

"Expert" menu → Communication → Diagnostic event category



Available status signals

Configuration as per HART 7 Specification (Condensed Status), in accordance with NAMUR NE107.

Symbol	Meaning
F A0013956	Failure A device error has occurred. The measured value is no longer valid.
C A0013959	Function check The device is in service mode (e.g. during a simulation).
S A0013958	Out of specification The device is being operated: <ul style="list-style-type: none"> ▪ Outside its technical specification limits (e.g. outside the process temperature range) ▪ Outside of the configuration carried out by the user (e.g. maximum flow in parameter 20 mA value)
M A0013957	Maintenance required Maintenance is required. The measured value is still valid.
N A0023076	Has no effect on the condensed status.

12.5 Overview of diagnostic information

 The amount of diagnostic information and the number of measured variables affected increase if the measuring device has one or more application packages.

 In the case of some items of diagnostic information, the status signal and the diagnostic behavior can be changed. Adapt the diagnostic information (→  78)

Diagnostic number	Short text	Remedy instructions	Status signal [from the factory]	Diagnostic behavior [from the factory]
Diagnostic of sensor				
004	Sensor	1. Change sensor 2. Contact service	S	Alarm
022	Sensor temperature	1. Change main electronic module 2. Change sensor	F	Alarm
043	Sensor short circuit	1. Check sensor and cable 2. Change sensor or cable	S	Warning
062	Sensor connection	1. Check sensor connections 2. Contact service	F	Alarm
082	Data storage	1. Check module connections 2. Contact service	F	Alarm
083	Memory content	1. Restart device 2. Contact service	F	Alarm
190	Special event 1	Contact service	F	Alarm
Diagnostic of electronic				
201	Device failure	1. Restart device 2. Contact service	F	Alarm
222	Electronic drift	Change main electronic module	F	Alarm
242	Software incompatible	1. Check software 2. Flash or change main electronics module	F	Alarm
252	Modules incompatible	1. Check electronic modules 2. Change electronic modules	F	Alarm
261	Electronic modules	1. Restart device 2. Check electronic modules 3. Change I/O Modul or main electronics	F	Alarm
262	Module connection	1. Check module connections 2. Change main electronics	F	Alarm
270	Main electronic failure	Change main electronic module	F	Alarm
271	Main electronic failure	1. Restart device 2. Change main electronic module	F	Alarm
272	Main electronic failure	1. Restart device 2. Contact service	F	Alarm
273	Main electronic failure	Change electronic	F	Alarm
281	Electronic initialization	Firmware update active, please wait!	F	Alarm
283	Memory content	1. Reset device 2. Contact service	F	Alarm
302	Device verification active	Device verification active, please wait.	C	Warning
311	Electronic failure	1. Reset device 2. Contact service	F	Alarm
311	Electronic failure	1. Do not reset device 2. Contact service	M	Warning
322	Electronic drift	1. Perform verification manually 2. Change electronic	S	Warning
375	I/O communication failed	1. Restart device 2. Change main electronic module	F	Alarm



Diagnostic number	Short text	Remedy instructions	Status signal [from the factory]	Diagnostic behavior [from the factory]
382	Data storage	1. Insert DAT module 2. Change DAT module	F	Alarm
383	Memory content	1. Restart device 2. Check or change DAT module 3. Contact service	F	Alarm
390	Special event 2	Contact service	F	Alarm
Diagnostic of configuration				
410	Data transfer	1. Check connection 2. Retry data transfer	F	Alarm
411	Up-/download active	Up-/download active, please wait	C	Warning
431	Trim 1	Carry out trim	C	Warning
437	Configuration incompatible	1. Restart device 2. Contact service	F	Alarm
438	Dataset	1. Check data set file 2. Check device configuration 3. Up- and download new configuration	M	Warning
441	Current output 1	1. Check process 2. Check current output settings	S	Warning ¹⁾
442	Frequency output	1. Check process 2. Check frequency output settings	S	Warning ¹⁾
443	Pulse output	1. Check process 2. Check pulse output settings	S	Warning ¹⁾
453	Flow override	Deactivate flow override	C	Warning
484	Simulation failure mode	Deactivate simulation	C	Alarm
485	Simulation measured variable	Deactivate simulation	C	Warning
491	Simulation current output 1	Deactivate simulation	C	Warning
492	Simulation frequency output	Deactivate simulation frequency output	C	Warning
493	Simulation pulse output	Deactivate simulation pulse output	C	Warning
494	Switch output simulation	Deactivate simulation switch output	C	Warning
495	Simulation diagnostic event	Deactivate simulation	C	Warning
500	Electrode 1 potential exceeded	1. Check process cond. 2. Increase system pressure	F	Alarm
500	Electrode difference voltage too high	1. Check process cond. 2. Increase system pressure	F	Alarm
530	Electrode cleaning is running	1. Check process cond. 2. Increase system pressure	C	Warning
531	Empty pipe detection	Execute EPD adjustment	S	Warning
537	Configuration	1. Check IP addresses in network 2. Change IP address	F	Warning
590	Special event 3	Contact service	F	Alarm
Diagnostic of process				
803	Current loop	1. Check wiring 2. Change I/O module	F	Alarm

Diagnostic number	Short text	Remedy instructions	Status signal [from the factory]	Diagnostic behavior [from the factory]
832	Electronic temperature too high	Reduce ambient temperature	S	Warning ¹⁾
833	Electronic temperature too low	Increase ambient temperature	S	Warning ¹⁾
834	Process temperature too high	Reduce process temperature	S	Warning ¹⁾
835	Process temperature too low	Increase process temperature	S	Warning ¹⁾
842	Process limit	Low flow cut off active! 1. Check low flow cut off configuration	S	Warning
862	Empty pipe	1. Check for gas in process 2. Adjust empty pipe detection	S	Warning
882	Input signal	1. Check input configuration 2. Check external device or process conditions	F	Alarm
937	EMC interference	Change main electronic module	S	Warning ¹⁾
938	EMC interference	1. Check ambient conditions regarding EMC influence 2. Change main electronic module	F	Alarm
990	Special event 4	Contact service	F	Alarm

1) Diagnostic status is changeable.

12.6 Pending diagnostic events

The **Diagnostics** menu allows the user to view the current diagnostic event and the previous diagnostic event separately.

-  To call up the measures to rectify a diagnostic event:
 - Via Web browser
 - Via "FieldCare" operating tool (→  77)

-  Other pending diagnostic events can be displayed in the **Diagnostic list** submenu(→  82)

Navigation

"Diagnostics" menu

Structure of the submenu

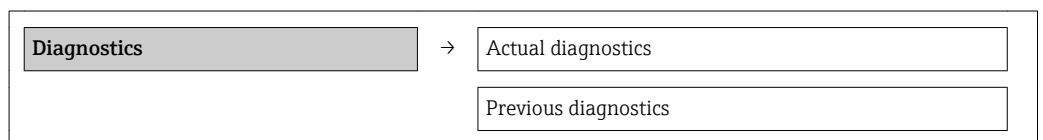

Parameter overview with brief description



Parameter	Prerequisite	Description	User interface	Factory setting
Actual diagnostics	1 diagnostic event has occurred.	Displays the current diagnostic event along with the diagnostic information.  If two or more messages occur simultaneously, the message with the highest priority is shown on the display.	Symbol for diagnostic behavior, diagnostic code and short message.	–
Previous diagnostics	2 diagnostic events have already occurred.	Displays the diagnostic event that occurred prior to the current diagnostic event along with the diagnostic information.	Symbol for diagnostic behavior, diagnostic code and short message.	–

12.7 Diagnostic list

In the **Diagnostic list** submenu, up to 5 currently pending diagnostic events can be displayed along with the related diagnostic information. If more than 5 diagnostic events are pending, the events with the highest priority are shown on the display.

Navigation path

Diagnostics menu → **Diagnostic list** submenu

-  To call up the measures to rectify a diagnostic event:
- Via Web browser
 - Via "FieldCare" operating tool (→  77)

12.8 Event logbook



12.8.1 Event history

A chronological overview of the event messages that have occurred is provided in the **Events list** submenu.



Navigation path



"Diagnostics" menu → Event logbook → Events list



The event history includes entries for:

- Diagnostic events (→  78)
- Information events (→  83)

In addition to the operation time of its occurrence, each event is also assigned a symbol that indicates whether the event has occurred or is ended:

- Diagnostic event
 - : Event has occurred
 - : Event has ended
- Information event
 - : Event has occurred

-  To call up the measures to rectify a diagnostic event:
- Via Web browser
 - Via "FieldCare" operating tool (→  77)

-  For filtering the displayed event messages (→  83)

12.8.2 Filtering the event logbook

Using the **Filter options** parameter, you can define which category of event messages is displayed in the **Events list** submenu.

Navigation path

"Diagnostics" menu → Event logbook → Filter options

Filter categories

- All
- Failure (F)
- Function check (C)
- Out of specification (S)
- Maintenance required (M)
- Information (I)

12.8.3 Overview of information events

Unlike a diagnostic event, an information event is displayed in the event logbook only and not in the diagnostic list.

Info number	Info name
I1000	----- (Device ok)
I1089	Power on
I1090	Configuration reset
I1091	Configuration changed
I1110	Write protection switch changed
I1137	Electronic changed
I1151	History reset
I1155	Reset electronic temperature
I1157	Memory error event list
I1185	Display backup done
I1186	Restore via display done
I1187	Settings downloaded with display
I1188	Display data cleared
I1189	Backup compared
I1256	Display: access status changed
I1264	Safety sequence aborted
I1278	I/O module reset detected
I1335	Firmware changed
I1351	Empty pipe detection adjustment failure
I1353	Empty pipe detection adjustment ok
I1361	Wrong web server login
I1397	Fieldbus: access status changed
I1398	CDI: access status changed
I1444	Device verification passed
I1445	Device verification failed
I1457	Failed: Measured error verification
I1459	Failed: I/O module verification

Info number	Info name
I1461	Failed: Sensor verification
I1462	Failed:Sensor electronic module verific.

12.9 Resetting the measuring device

Using the **Device reset** parameter it is possible to reset the entire device configuration or some of the configuration to a defined state.

"Setup" menu → Advanced setup → Administration

Function scope of "Device reset" parameter

Options	Description
Cancel	No action is executed and the user exits the parameter.
To delivery settings	Every parameter for which a customer-specific default setting was ordered is reset to this customer-specific value. All other parameters are reset to the factory setting.  This option is not visible if no customer-specific settings have been ordered.
Restart device	The restart resets every parameter whose data are in the volatile memory (RAM) to the factory setting (e.g. measured value data). The device configuration remains unchanged.
History reset	Every parameter is reset to its factory setting.

12.10 Device information

The **Device information** submenu contains all the parameters that display different information for identifying the device.

Navigation

"Diagnostics" menu → Device information

Device information	→	Device tag
		Serial number
		Firmware version
		Device name
		Order code
		Extended order code 1
		Extended order code 2
		Extended order code 3
		ENP version
		Device revision
		Device ID
		Device type

	Manufacturer ID
	IP address
	Subnet mask
	Default gateway

Parameter overview with brief description

Parameter	Description	User interface	Factory setting
Device tag	Enter tag for measuring point.	Max. 32 characters, such as letters, numbers or special characters (e.g. @, %, /)	Promag 100
Serial number	Displays the serial number of the measuring device.	Max. 11-digit character string comprising letters and numbers.	79AFF16000
Firmware version	Displays the device firmware version installed.	Character string with the following format: xx.yy.zz	01.01
Device name	Displays the name of the transmitter.	Character string composed of letters, numbers and certain punctuation marks.	Promag 100
Order code	Displays the device order code.	Character string composed of letters, numbers and certain punctuation marks	-
Extended order code 1	Displays the 1st part of the extended order code.	Character string	-
Extended order code 2	Displays the 2nd part of the extended order code.	Character string	-
Extended order code 3	Displays the 3rd part of the extended order code.	Character string	-
ENP version	Displays the version of the electronic nameplate.	Character string in the format xx.yy.zz	2.02.00
Device revision	Displays the device revision with which the device is registered with the HART Communication Foundation.	0 to 255	2
Device ID	Displays the device ID for identifying the device in a HART network.	Positive integer	6-digit hexadecimal number
Device type	Displays the device type with which the measuring device is registered with the HART Communication Foundation.	0 to 255	58
Manufacturer ID	Displays the manufacturer ID with which the measuring device is registered with the HART Communication Foundation.	0 to 255	17
IP address	Displays the IP address of the Web server of the measuring device.	4 octet: 0 to 255 (in the particular octet)	192.168.1.212
Subnet mask	Displays the subnet mask.	4 octet: 0 to 255 (in the particular octet)	255.255.255.0
Default gateway	Displays the default gateway.	4 octet: 0 to 255 (in the particular octet)	0.0.0.0

12.11 Firmware history

Release date	Firmware version	Order code for "Firmware version"	Firmware changes	Documentation type	Documentation
04.2013	01.00.00	Option 76	Original firmware	Operating Instructions	BA01171D/06/EN/01.13
06.2014	01.01.zz	Option 70	<ul style="list-style-type: none"> ▪ In accordance with HART 7 Specification ▪ Integration of optional onsite display ▪ New unit "Beer Barrel (BBL)" ▪ Simulation of diagnostic events ▪ External verification of the current and PFS output via the Heartbeat application package ▪ Fixed value for simulation pulses 	Operating Instructions	BA01171D/06/EN/02.14

 Flashing the firmware to the current version or to the previous version is possible via the service interface (CDI) .

 For the compatibility of the firmware version with the previous version, the installed device description files and operating tools, observe the information about the device in the "Manufacturer's information" document.

 The manufacturer's information is available:

- In the Download Area of the Endress+Hauser Internet site: www.endress.com → Download
- Specify the following details:
 - Product root: e.g. 5H1B
 - Text search: Manufacturer's information
 - Search range: documentation

13 Maintenance

13.1 Maintenance tasks

No special maintenance work is required.

13.1.1 Exterior cleaning

When cleaning the exterior of measuring devices, always use cleaning agents that do not attack the surface of the housing or the seals.

13.1.2 Interior cleaning

No interior cleaning is planned for the device.

13.1.3 Replacing seals

The sensor's seals (particularly aseptic molded seals) must be replaced periodically.

The interval between changes depends on the frequency of the cleaning cycles, the cleaning temperature and the medium temperature.

Replacement seals (accessory) (→  109)

13.2 Measuring and test equipment

Endress+Hauser offers a wide variety of measuring and test equipment, such as W@M or device tests.

 Your Endress+Hauser Sales Center can provide detailed information on the services.

 For a list of some of the measuring and test equipment, refer to the "Accessories" chapter of the "Technical Information" document for the device.

13.3 Endress+Hauser services

Endress+Hauser offers a wide variety of services for maintenance such as recalibration, maintenance service or device tests.

 Your Endress+Hauser Sales Center can provide detailed information on the services.

14 Repair

14.1 General notes

Repair and conversion concept

The Endress+Hauser repair and conversion concept provides for the following:

- The measuring devices have a modular design.
- Spare parts are grouped into logical kits with the associated Installation Instructions.
- Repairs are carried out by Endress+Hauser Service or by correspondingly trained customers.
- Certified devices can be converted into other certified devices by Endress+Hauser Service or at the factory only.

Notes for repair and conversion

For repair and modification of a measuring device, observe the following notes:

- Use only original Endress+Hauser spare parts.
- Carry out the repair according to the Installation Instructions.
- Observe the applicable standards, federal/national regulations, Ex documentation (XA) and certificates.
- Document every repair and each conversion and enter them into the *W@M* life cycle management database.

14.2 Spare parts



Measuring device serial number:

- Is located on the nameplate of the device.
- Can be read out via the **Serial number** parameter in the **Device information** submenu (→ 84).

14.3 Endress+Hauser services



Contact your Endress+Hauser Sales Center for information on services and spare parts.

14.4 Return

The measuring device must be returned if repairs or a factory calibration are required, or if the wrong measuring device has been ordered or delivered. According to legal regulations, Endress+Hauser, as an ISO-certified company, is required to follow certain procedures when handling returned products that are in contact with medium.

To ensure swift, safe and professional device returns, please read the return procedures and conditions on the Endress+Hauser website at

www.services.endress.com/return-material

14.5 Disposal

14.5.1 Removing the measuring device

1. Switch off the device.
2. **WARNING!** Danger to persons from process conditions. Beware of hazardous process conditions such as pressure in the measuring device, high temperatures or aggressive fluids.

Carry out the mounting and connection steps from the chapters "Mounting the measuring device" and "Connecting the measuring device" in the logically reverse sequence. Observe the safety instructions.

14.5.2 Disposing of the measuring device

⚠ WARNING

Danger to personnel and environment from fluids that are hazardous to health.

- ▶ Ensure that the measuring device and all cavities are free of fluid residues that are hazardous to health or the environment, e.g. substances that have permeated into crevices or diffused through plastic.

Observe the following notes during disposal:

- Observe valid federal/national regulations.
- Ensure proper separation and reuse of the device components.

15 Accessories

Various accessories, which can be ordered with the device or subsequently from Endress+Hauser, are available for the device. Detailed information on the order code in question is available from your local Endress+Hauser sales center or on the product page of the Endress+Hauser website: www.endress.com.

15.1 Device-specific accessories







15.1.1 For the transmitter

Accessories	Description
Adapter set	Adapter connections for installing Promag H instead of a Promag 30/33 A or Promag 30/33 H (DN 25) device. Consists of: <ul style="list-style-type: none"> ▪ 2 process connections ▪ Threaded fasteners ▪ Seals
Seal set	For the regular replacement of seals for the sensor.
Spacer	If replacing a DN 80/100 sensor in an existing installation, a spacer is needed if the new sensor is shorter.
Welding jig	Welded connection as process connection: welding jig for installation in pipe.
Grounding rings	Are used to ground the fluid in lined measuring tubes to ensure proper measurement.  For details, see Installation Instructions EA00070D
Mounting kit	Consists of: <ul style="list-style-type: none"> ▪ 2 process connections ▪ Threaded fasteners ▪ Seals
Wall mounting kit	Wall mounting kit for measuring device (only DN 2 to 25 (1/12 to 1"))

15.1.2 For the sensor

Accessories	Description
Adapter set	Adapter connections for installing Promag H instead of a Promag 30/33 A or Promag 30/33 H (DN 25) device. Consists of: <ul style="list-style-type: none"> ▪ 2 process connections ▪ Threaded fasteners ▪ Seals
Seal set	For the regular replacement of seals for the sensor.
Spacer	If replacing a DN 80/100 sensor in an existing installation, a spacer is needed if the new sensor is shorter.
Welding jig	Welded connection as process connection: welding jig for installation in pipe.
Grounding rings	Are used to ground the fluid in lined measuring tubes to ensure proper measurement.  For details, see Installation Instructions EA00070D
Mounting kit	Consists of: <ul style="list-style-type: none"> ▪ 2 process connections ▪ Threaded fasteners ▪ Seals
Wall mounting kit	Wall mounting kit for measuring device (only DN 2 to 25 (1/12 to 1"))

15.2 Communication-specific accessories

Accessories	Description
Commubox FXA195 HART	For intrinsically safe HART communication with FieldCare via the USB interface.  For details, see "Technical Information" TI00404F
HART Loop Converter HMX50	Is used to evaluate and convert dynamic HART process variables to analog current signals or limit values.  For details, see "Technical Information" TI00429F and Operating Instructions BA00371F
Wireless HART adapter SWA70	Is used for the wireless connection of field devices. The WirelessHART adapter can be easily integrated into field devices and existing infrastructures, offers data protection and transmission safety and can be operated in parallel with other wireless networks with minimum cabling complexity.  For details, see Operating Instructions BA00061S
Fieldgate FXA320	Gateway for the remote monitoring of connected 4-20 mA measuring devices via a Web browser.  For details, see "Technical Information" TI00025S and Operating Instructions BA00053S
Fieldgate FXA520	Gateway for the remote diagnostics and remote configuration of connected HART measuring devices via a Web browser.  For details, see "Technical Information" TI00025S and Operating Instructions BA00051S
Field Xpert SFX350	Field Xpert SFX350 is a mobile computer for commissioning and maintenance. It enables efficient device configuration and diagnostics for HART and FOUNDATION Fieldbus devices in the non-Ex area .  For details, see Operating Instructions BA01202S
Field Xpert SFX370	Field Xpert SFX370 is a mobile computer for commissioning and maintenance. It enables efficient device configuration and diagnostics for HART and FOUNDATION Fieldbus devices in the non-Ex area and the Ex area .  For details, see Operating Instructions BA01202S

15.3 Service-specific accessories

Accessories	Description
Applicator	Software for selecting and sizing Endress+Hauser measuring devices: <ul style="list-style-type: none"> ▪ Calculation of all the necessary data for identifying the optimum flowmeter: e.g. nominal diameter, pressure loss, accuracy or process connections. ▪ Graphic illustration of the calculation results Administration, documentation and access to all project-related data and parameters over the entire life cycle of a project. Applicator is available: <ul style="list-style-type: none"> ▪ Via the Internet: https://wapps.endress.com/applicator ▪ On CD-ROM for local PC installation.

W@M	<p>Life cycle management for your plant</p> <p>W@M supports you with a wide range of software applications over the entire process: from planning and procurement, to the installation, commissioning and operation of the measuring devices. All the relevant device information, such as the device status, spare parts and device-specific documentation, is available for every device over the entire life cycle.</p> <p>The application already contains the data of your Endress+Hauser device. Endress+Hauser also takes care of maintaining and updating the data records.</p> <p>W@M is available:</p> <ul style="list-style-type: none"> ■ Via the Internet: www.endress.com/lifecyclemanagement ■ On CD-ROM for local PC installation.
FieldCare	<p>FDT-based plant asset management tool from Endress+Hauser.</p> <p>It can configure all smart field units in your system and helps you manage them. By using the status information, it is also a simple but effective way of checking their status and condition.</p> <p> For details, see Operating Instructions BA00027S and BA00059S</p>

15.4 System components

Accessories	Description
Memograph M graphic display recorder	<p>The Memograph M graphic display recorder provides information on all relevant measured variables. Measured values are recorded correctly, limit values are monitored and measuring points analyzed. The data are stored in the 256 MB internal memory and also on a SD card or USB stick.</p> <p> For details, see "Technical Information" TI00133R and Operating Instructions BA00247R</p>

16 Technical data

16.1 Application

Depending on the version ordered, the measuring device can also measure potentially explosive, flammable, poisonous and oxidizing media.

To ensure that the device remains in proper operating condition for its service life, use the measuring device only for media against which the process-wetted materials are adequately resistant.

16.2 Function and system design

Measuring principle	Electromagnetic flow measurement on the basis of <i>Faraday's law of magnetic induction</i> .
Measuring system	One device version is available: compact version, transmitter and sensor form a mechanical unit. For information on the structure of the device (→  11)

16.3 Input

Measured variable	<p>Direct measured variables</p> <ul style="list-style-type: none"> ■ Volume flow (proportional to induced voltage) ■ Temperature (DN 15 to 150 (½ to 6")) ■ Electrical conductivity <p>Calculated measured variables</p> <ul style="list-style-type: none"> ■ Mass flow ■ Corrected volume flow ■ Corrected electrical conductivity
Measuring range	Typically $v = 0.01$ to 10 m/s (0.03 to 33 ft/s) with the specified accuracy Electrical conductivity: 5 to $10\,000$ $\mu\text{S/cm/cm}$

Flow characteristic values in SI units

Nominal diameter		Recommended flow min./max. full scale value ($v \sim 0.3/10$ m/s) [dm ³ /min]	Factory settings		
[mm]	[in]		Full scale value current output ($v \sim 2.5$ m/s) [dm ³ /min]	Pulse value (~ 2 pulse/s) [dm ³]	Low flow cut off ($v \sim 0.04$ m/s) [dm ³ /min]
2	1/12	0.06 to 1.8	0.5	0.005	0.01
4	1/8	0.25 to 7	2	0.025	0.05
8	3/8	1 to 30	8	0.1	0.1
15	½	4 to 100	25	0.2	0.5
25	1	9 to 300	75	0.5	1
40	1 ½	25 to 700	200	1.5	3

Nominal diameter		Recommended flow min./max. full scale value (v ~ 0.3/10 m/s)	Factory settings		
[mm]	[in]		Full scale value current output (v ~ 2.5 m/s)	Pulse value (~ 2 pulse/s)	Low flow cut off (v ~ 0.04 m/s)
		[dm ³ /min]	[dm ³ /min]	[dm ³]	[dm ³ /min]
50	2	35 to 1 100	300	2.5	5
65	-	60 to 2 000	500	5	8
80	3	90 to 3 000	750	5	12
100	4	145 to 4 700	1200	10	20
125	5	220 to 7 500	1850	15	30
150	6	20 to 600 m ³ /h	150 m ³ /h	0.03 m ³	2.5 m ³ /h

Flow characteristic values in US units

Nominal diameter		Recommended flow min./max. full scale value (v ~ 0.3/10 m/s)	Factory settings		
[in]	[mm]		Full scale value current output (v ~ 2.5 m/s)	Pulse value (~ 2 pulse/s)	Low flow cut off (v ~ 0.04 m/s)
		[gal/min]	[gal/min]	[gal]	[gal/min]
1/12	2	0.015 to 0.5	0.1	0.001	0.002
1/8	4	0.07 to 2	0.5	0.005	0.008
3/8	8	0.25 to 8	2	0.02	0.025
½	15	1 to 27	6	0.05	0.1
1	25	2.5 to 80	18	0.2	0.25
1 ½	40	7 to 190	50	0.5	0.75
2	50	10 to 300	75	0.5	1.25
3	80	24 to 800	200	2	2.5
4	100	40 to 1 250	300	2	4
5	125	60 to 1 950	450	5	7
6	150	90 to 2 650	600	5	12

Recommended measuring range

"Flow limit" section (→  101)

Operable flow range Over 1000 : 1

Input signal

External measured values

To increase the accuracy of certain measured variables or to calculate the corrected volume flow, the automation system can continuously write different measured values to the measuring device:

- Operating pressure to increase accuracy (Endress+Hauser recommends the use of a pressure measuring device for absolute pressure, e.g. Cerabar M or Cerabar S)
- Medium temperature to increase accuracy (e.g. iTEMP)
- Reference density for calculating the corrected volume flow

 Various pressure transmitters and temperature measuring devices can be ordered from Endress+Hauser: see "Accessories" section (→  92)

It is recommended to read in external measured values to calculate the following measured variables:

Corrected volume flow

HART protocol

The measured values are written from the automation system to the measuring device via the HART protocol. The pressure transmitter must support the following protocol-specific functions:

- HART protocol
- Burst mode

16.4 Output

Output signal

Current output

Current output	4-20 mA HART (active)
Maximum output values	<ul style="list-style-type: none"> ■ DC 24 V (no flow) ■ 22.5 mA
Load	0 to 700 Ω
Resolution	0.38 μ A
Damping	Adjustable: 0.07 to 999 s
Assignable measured variables	<ul style="list-style-type: none"> ■ Volume flow ■ Mass flow ■ Corrected volume flow ■ Flow velocity ■ Conductivity ■ Corrected conductivity ■ Temperature ■ Electronic temperature

Pulse/frequency/switch output

Function	Can be set to pulse, frequency or switch output
Version	Passive, open collector
Maximum input values	<ul style="list-style-type: none"> ■ DC 30 V ■ 25 mA
Voltage drop	For 25 mA: \leq DC 2 V
Pulse output	
Pulse width	Adjustable: 0.05 to 2 000 ms
Maximum pulse rate	10 000 Impulse/s
Pulse value	Adjustable
Assignable measured variables	<ul style="list-style-type: none"> ■ Volume flow ■ Mass flow ■ Corrected volume flow
Frequency output	
Output frequency	Adjustable: 0 to 10 000 Hz
Damping	Adjustable: 0 to 999 s
Pulse/pause ratio	1:1

Assignable measured variables	<ul style="list-style-type: none"> ■ Volume flow ■ Mass flow ■ Corrected volume flow ■ Flow velocity ■ Conductivity ■ Corrected conductivity ■ Temperature ■ Electronic temperature
Switch output	
Switching behavior	Binary, conductive or non-conductive
Switching delay	Adjustable: 0 to 100 s
Number of switching cycles	Unlimited
Assignable functions	<ul style="list-style-type: none"> ■ Off ■ On ■ Diagnostic behavior ■ Limit value: <ul style="list-style-type: none"> - Off - Volume flow - Mass flow - Corrected volume flow - Flow velocity - Conductivity - Corrected conductivity - Totalizer 1-3 - Temperature - Electronic temperature ■ Flow direction monitoring ■ Status <ul style="list-style-type: none"> - Empty pipe detection - Low flow cut off

Signal on alarm

Depending on the interface, failure information is displayed as follows:

Current output

4-20 mA

Failure mode	Selectable (as per NAMUR recommendation NE 43): <ul style="list-style-type: none"> ■ Minimum value: 3.6 mA ■ Maximum value: 22 mA ■ Defined value: 3.59 to 22.5 mA ■ Actual value ■ Last valid value
---------------------	---

HART

Device diagnostics	Device condition can be read out via HART Command 48
---------------------------	--

Pulse/frequency/switch output

Pulse output	
Failure mode	Choose from: <ul style="list-style-type: none"> ■ Actual value ■ No pulses
Frequency output	
Failure mode	Choose from: <ul style="list-style-type: none"> ■ Actual value ■ Defined value: 0 to 12 500 Hz ■ 0 Hz

Switch output	
Failure mode	Choose from: <ul style="list-style-type: none"> ▪ Current status ▪ Open ▪ Closed

Local display

Plain text display	With information on cause and remedial measures
Backlight	Red backlighting indicates a device error.

 Status signal as per NAMUR recommendation NE 107



Operating tool

- Via digital communication:
 - HART protocol
- Via service interface



Plain text display	With information on cause and remedial measures
--------------------	---

Web browser

Plain text display	With information on cause and remedial measures
--------------------	---

Low flow cut off	The switch points for low flow cut off are user-selectable.
Galvanic isolation	The following connections are galvanically isolated from each other: <ul style="list-style-type: none"> ▪ Outputs ▪ Power supply
Protocol-specific data	<p>HART</p> <ul style="list-style-type: none"> ▪ For information on the device description files (→  45) ▪ For information on the dynamic variables and measured variables (HART device variables) (→  45)

16.5 Power supply

Terminal assignment	(→  28)
Pin assignment, device plug	(→  29)
Supply voltage	<p>Transmitter</p> <p>For device version with all communication types: DC 20 to 30 V</p> <p>The power unit must be tested to ensure it meets safety requirements (e.g. PELV, SELV).</p>

Power consumption

Transmitter

Order code for "Output"	Maximum Power consumption
Option B : 4-20mA HART, pulse/frequency/switch output	3.5 W

Current consumption

Transmitter

Order code for "Output"	Maximum Current consumption	Maximum switch-on current
Option B : 4-20mA HART, pul./freq./switch output	145 mA	18 A (<0.125 ms)

Power supply failure

- Totalizers stop at the last value measured.
- Depending on the device version, the configuration is retained in the device memory or in the plug-in memory (HistoROM DAT).
- Error messages (incl. total operated hours) are stored.

Electrical connection

(→  29)

Potential equalization

(→  31)

Terminals

Transmitter

Spring terminals for wire cross-sections 0.5 to 2.5 mm² (20 to 14 AWG)

Cable entries

- Cable gland: M20 × 1.5 with cable ϕ 6 to 12 mm (0.24 to 0.47 in)
- Thread for cable entry:
 - NPT 1/2"
 - G 1/2"
 - M20

Cable specification

(→  27)

16.6 Performance characteristics

Reference operating conditions

In accordance with DIN EN 29104

- Fluid temperature: +28±2 °C (+82±4 °F)
- Ambient temperature range: +22±2 °C (+72±4 °F)
- Warm-up period: 30 min

Installation

- Inlet run > 10 × DN
- Outlet run > 5 × DN
- Sensor and transmitter grounded.
- The sensor is centered in the pipe.

Maximum measured error

Error limits under reference operating conditions

o.r. = of reading

Volume flow

- ±0.5 % o.r. ± 1 mm/s (0.04 in/s)
- Optional: ±0.2 % o.r. ± 2 mm/s (0.08 in/s)

i Fluctuations in the supply voltage do not have any effect within the specified range.

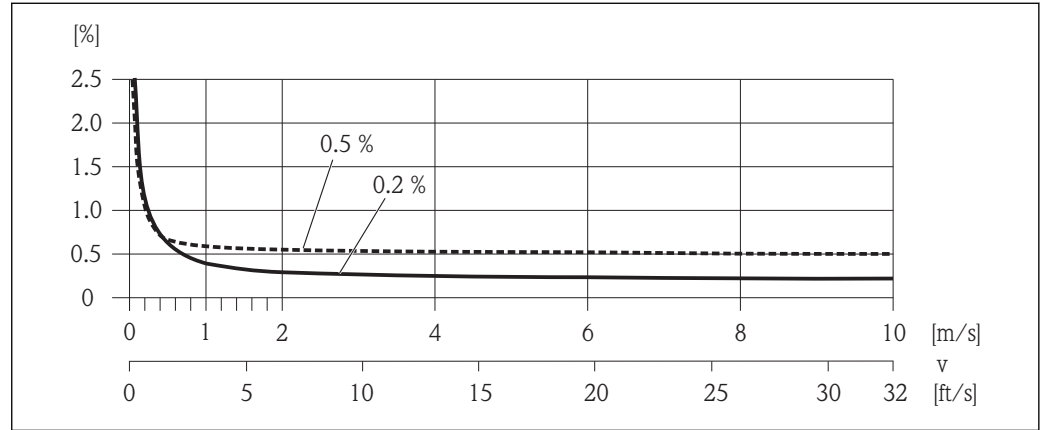

15 Maximum measured error in % o.r.

Temperature

±3 °C (±5.4 °F)

Electrical conductivity

Max. measured error not specified.

Accuracy of outputs

o.r. = of reading; o.f.s. = of full scale value

i The output accuracy must be factored into the measured error if analog outputs are used, but can be ignored for fieldbus outputs (e.g. Modbus RS485, EtherNet/IP).

Current output

Accuracy	Max. ±0.05 % o.f.s. or ±5 µA
-----------------	------------------------------

Pulse/frequency output

Accuracy	Max. ±50 ppm o.r.
-----------------	-------------------

Repeatability

o.r. = of reading

Volume flow

Max. ±0.1 % o.r. ± 0.5 mm/s (0.02 in/s)

Temperature

±0.5 °C (±0.9 °F)

Electrical conductivity

Max. ±5 % o.r.

Temperature measurement response time

T₉₀ < 15 s

Influence of ambient temperature o.r. = of reading; o.f.s. = of full scale value

Current output

Temperature coefficient	Max. ±50 ppm/°C o.f.s. or ±1 µA/°C
-------------------------	------------------------------------

Pulse/frequency output

Temperature coefficient	Max. ±50 ppm o.r. /100 °C
-------------------------	---------------------------

16.7 Installation

"Mounting requirements" (→  17)

16.8 Environment

Ambient temperature range (→  19)

Storage temperature The storage temperature corresponds to the operating temperature range of the measuring transmitter and the appropriate measuring sensors.

- Protect the measuring device against direct sunlight during storage in order to avoid unacceptably high surface temperatures.
- Select a storage location where moisture cannot collect in the measuring device as fungus or bacteria infestation can damage the liner.
- If protection caps or protective covers are mounted these should never be removed before installing the measuring device.

Degree of protection **Transmitter and sensor**

- As standard: IP66/67, type 4X enclosure
- With the order code for "Sensor options", option **CM**: IP69K can also be ordered
- When housing is open: IP20, type 1 enclosure
- Display module: IP20, type 1 enclosure

Shock resistance As per IEC/EN 60068-2-31

Vibration resistance Acceleration up to 2 g following IEC 60068-2-6

Mechanical load

- Protect the transmitter housing against mechanical effects, such as shock or impact.
- Never use the transmitter housing as a ladder or climbing aid.

Interior cleaning

- Cleaning in place (CIP)
- Sterilization in place (SIP)

Electromagnetic compatibility (EMC)

- As per IEC/EN 61326 and NAMUR Recommendation 21 (NE 21)
- Complies with emission limits for industry as per EN 55011 (Class A)

 For details refer to the Declaration of Conformity.

16.9 Process

Medium temperature range -20 to +150 °C (-4 to +302 °F)

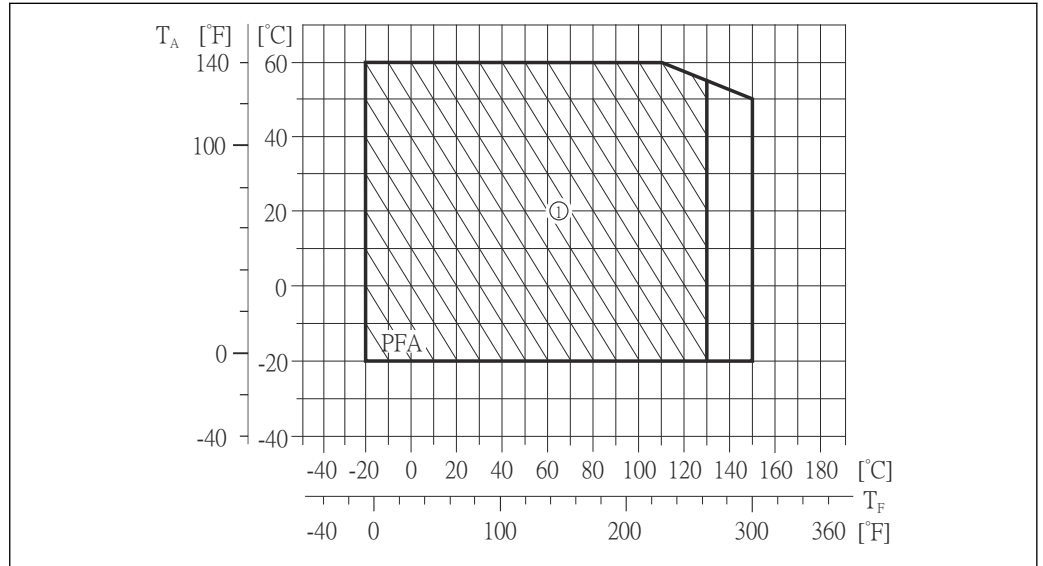

T_A Ambient temperature

T_F Medium temperature

1 Harsh environment and IP68 only to +130 °C (+266 °F)

Conductivity $\geq 5 \mu\text{S/cm}$ for liquids in general

Pressure-temperature ratings



An overview of the pressure-temperature ratings for the process connections is provided in the "Technical Information" document

Pressure tightness

Liner: PFA

Nominal diameter		Limit values for absolute pressure in [mbar] ([psi]) for fluid temperatures:				
[mm]	[in]	+25 °C (+77 °F)	+80 °C (+176 °F)	+100 °C (+212 °F)	+130 °C (+266 °F)	+150 °C (+302 °F)
2 to 150	1/12 to 6	0 (0)	0 (0)	0 (0)	0 (0)	0 (0)

Flow limit

The diameter of the pipe and the flow rate determine the nominal diameter of the sensor. The optimum velocity of flow is between 2 to 3 m/s (6.56 to 9.84 ft/s). Also match the velocity of flow (v) to the physical properties of the fluid:

- $v < 2 \text{ m/s}$ (6.56 ft/s): for low conductivity values
- $v > 2 \text{ m/s}$ (6.56 ft/s): for fluids producing buildup (e.g. milk with a high fat content)



A necessary increase in the flow velocity can be achieved by reducing the sensor nominal diameter.



For an overview of the measuring range full scale values, see the "Measuring range" section (\rightarrow 93)

Pressure loss	<ul style="list-style-type: none"> No pressure loss occurs as of nominal diameter DN 8 (3/8") if the sensor is installed in a pipe with the same nominal diameter. Pressure losses for configurations incorporating adapters according to DIN EN 545 (→  21)
---------------	---

System pressure	(→  20)
-----------------	--

Vibrations	(→  20)
------------	--

16.10 Mechanical construction

Design, dimensions	 For the dimensions and installation lengths of the device, see the "Technical Information" document, "Mechanical construction" section
--------------------	--

Weight	Compact version
	<ul style="list-style-type: none"> Including the transmitter Weight specifications apply to standard pressure ratings and without packaging material.

Nominal diameter		Weight	
[mm]	[in]	[kg]	[lbs]
2	1/12	2.00	4.41
4	1/8	2.00	4.41
8	3/8	2.00	4.41
15	½	1.90	4.19
25	1	2.80	6.17
40	1 ½	4.10	9.04
50	2	4.60	10.1
65	–	5.40	11.9
80	3	6.00	13.2
100	4	7.30	16.1
125	5	12.7	28.0
150	6	15.1	33.3

Measuring tube specification

Nominal diameter		Pressure rating ¹⁾ EN (DIN) [bar]	Process connection internal diameter	
[mm]	[in]		PFA	
			[mm]	[in]
2	1/12	PN 16/40	2.25	0.09
4	1/8	PN 16/40	4.5	0.18
8	3/8	PN 16/40	9.0	0.35
15	½	PN 16/40	16.0	0.63
–	1	PN 16/40	22.6	0.89
25	–	PN 16/40	26.0	1.02
40	1 ½	PN 16/25/40	35.3	1.39

Nominal diameter		Pressure rating ¹⁾ EN (DIN) [bar]	Process connection internal diameter	
[mm]	[in]		PFA	
			[mm]	[in]
50	2	PN 16/25	48.1	1.89
65	-	PN 16/25	59.9	2.36
80	3	PN 16/25	72.6	2.86
100	4	PN 16/25	97.5	3.84
125	5	PN 10/16	120.0	4.72
150	6	PN 10/16	146.5	5.77

1) Depending on process connection and seals used

Materials

Transmitter housing

- Order code for "Housing", option A "Compact, aluminum coated":
Aluminum, AlSi10Mg, coated
- Order code for "Housing", option B "Compact, hygienic, stainless":
Hygienic version, stainless steel 1.4301 (304)
- Order code for "Housing", option C "Ultra compact, hygienic, stainless":
Hygienic version, stainless steel 1.4301 (304)

Cable entries/cable glands

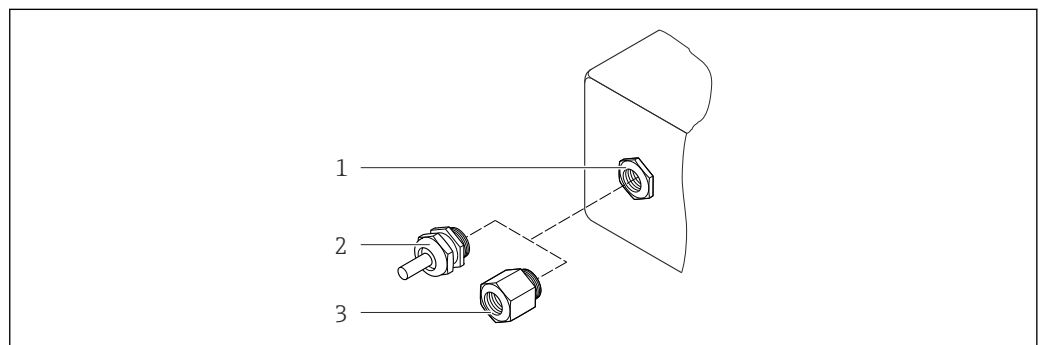

16 Possible cable entries/cable glands

- 1 Cable entry in transmitter housing, wall-mount housing or connection housing with internal thread M20 x 1.5
- 2 Cable gland M20 x 1.5
- 3 Adapter for cable entry with internal thread G 1/2" or NPT 1/2"

Order code for "Housing", option A "Compact, coated aluminum"

The various cable entries are suitable for hazardous and non-hazardous areas.

Cable entry/cable gland	Material
Cable gland M20 x 1.5	Nickel-plated brass
Adapter for cable entry with internal thread G 1/2"	
Adapter for cable entry with internal thread NPT 1/2"	

Order code for "Housing", option B "Compact, hygienic, stainless"

The various cable entries are suitable for hazardous and non-hazardous areas.

Cable entry/cable gland	Material
Cable gland M20 × 1.5	Stainless steel, 1.4404 (316L)
Adapter for cable entry with internal thread G ½"	
Adapter for cable entry with internal thread NPT ½"	

Device plug

Electrical connection	Material
Plug M12x1	<ul style="list-style-type: none"> ▪ Socket: Stainless steel, 1.4404 (316L) ▪ Contact housing: Polyamide ▪ Contacts: Gold-plated brass

Sensor housing

Stainless steel 1.4301 (304)

Measuring tubes



Stainless steel 1.4301 (304)

Liner

PFA (USP Class VI, FDA 21 CFR 177.1550, 3A)

Process connections

- Stainless steel 1.4404 (F316L)
- PVDF
- PVC adhesive sleeve

 List of all available process connections (→  105)

Electrodes

- Standard: 1.4435 (316L)
- Optional: Alloy C22, tantalum, platinum (only up to DN 25 (1"))

Seals

- O-ring seal, DN 2 to 25 (1/12 to 1"): EPDM, FKM, Kalrez
- Aseptic molded seal, DN 2 to 150 (1/12 to 6"): EPDM¹⁾, FKM, silicone¹⁾

Accessories

Grounding rings

- Standard: 1.4435 (F316L)
- Optional: Alloy C22, tantalum

Wall mounting kit



Stainless steel 1.4301 (304)

1) USP Class VI, FDA 21 CFR 177.2600, 3A

Spacer

1.4435 (F316L)

Fitted electrodes	<ul style="list-style-type: none"> ■ 2 measuring electrodes for signal detection ■ 1 empty pipe detection electrode for empty pipe detection/temperature measurement (only DN 15 to 150 (½ to 6"))
-------------------	--

Process connections	<p>With O-ring seal</p> <ul style="list-style-type: none"> ■ Welded connection (DIN EN ISO 1127, ODT/SMS, ISO 2037) ■ Flange (EN (DIN), ASME, JIS) ■ Flange from PVDF (EN (DIN), ASME, JIS) ■ External thread ■ Internal thread ■ Hose connection ■ PVC adhesive sleeve <p>With aseptic molded seal:</p> <ul style="list-style-type: none"> ■ Welded connection (DIN 11850, ASME BPE, ISO 2037) ■ Clamp (ISO 2852, ISO 2853, DIN 32676, L14 AM7) ■ Coupling (DIN 11851, DIN 11864-1, ISO 2853, SMS 1145) ■ Flange DIN 11864-2 <p> For information on the materials of the process connections (→  104)</p>
---------------------	---

Surface roughness	<p>Stainless steel electrodes, 1.4435 (F316L); Alloy C22, 2.4602 (UNS N06022); platinum; tantalum:</p> <p>≤ 0.3 to 0.5 μm (11.8 to 19.7 μin) (All data relate to parts in contact with fluid)</p> <p>Liner with PFA:</p> <p>≤ 0.4 μm (15.7 μin) (All data relate to parts in contact with fluid)</p> <p>Stainless steel process connections:</p> <p>≤ 0.8 μm (31 μin) Optional: ≤ 0.38 μm (15 μin) (All data relate to parts in contact with fluid)</p>
-------------------	---

16.11 Operability

Local display	<p>The local display is only available with the following device version: Order code for "Display; Operation", option B: 4-line; via communication</p> <p>Display element</p> <ul style="list-style-type: none"> ■ 4-line liquid crystal display with 16 characters per line. ■ White background lighting; switches to red in event of device errors. ■ Format for displaying measured variables and status variables can be individually configured. ■ Permitted ambient temperature for the display: -20 to +60 °C (-4 to +140 °F). The readability of the display may be impaired at temperatures outside the temperature range.
---------------	---

Disconnecting the local display from the main electronics module

i In the case of the "Compact, aluminum coated" housing version, the local display must only be disconnected manually from the main electronics module. In the case of the "Compact, hygienic, stainless" and "Ultra compact, hygienic, stainless" housing versions, the local display is integrated in the housing cover and is disconnected from the main electronics module when the housing cover is opened.

"Compact, aluminum coated" housing version

The local display is plugged onto the main electronics module. The electronic connection between the local display and main electronics module is established via a connecting cable.

For some work performed on the measuring device (e.g. electrical connection), it is advisable to disconnect the local display from the main electronics module:

1. Press in the side latches of the local display.
2. Remove the local display from the main electronics module. Pay attention to the length of the connecting cable when doing so.

Once the work is completed, plug the local display back on.

Remote operation

Via HART protocol

This communication interface is present in the following device version:
Order code for "Output", option **B**: 4-20 mA HART, pulse/frequency/switch output

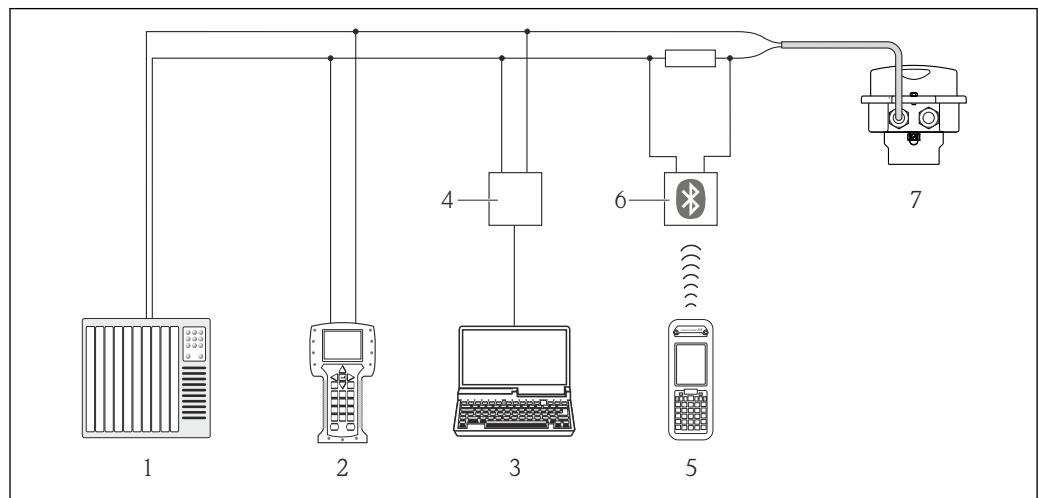

17 Options for remote operation via HART protocol

- 1 Control system (e.g. PLC)
- 2 Field Communicator 475
- 3 Computer with operating tool (e.g. FieldCare, AMS Device Manager, SIMATIC PDM)
- 4 Commubox FXA195 (USB)
- 5 Field Xpert SFX350 or SFX370
- 6 VIATOR Bluetooth modem with connecting cable
- 7 Transmitter

Service interface

Service interface (CDI-RJ45)

HART

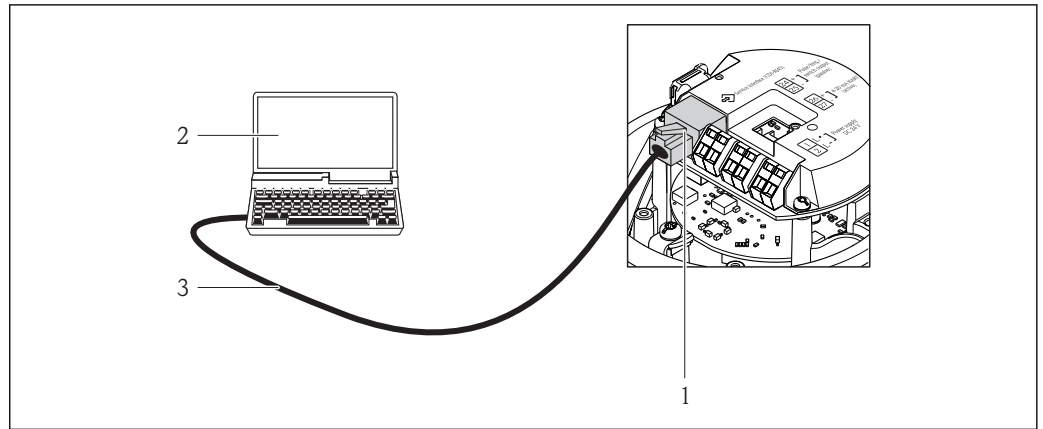

18 Connection for the order code for "Output", option B: 4-20 mA HART, pulse/frequency/switch output

- 1 Service interface (CDI -RJ45) of the measuring device with access to the integrated Web server
- 2 Computer with Web browser (e.g. Internet Explorer) for accessing the integrated device Web server or with "FieldCare" operating tool with COM DTM "CDI Communication TCP/IP"
- 3 Standard Ethernet connecting cable with RJ45 plug

Languages

Can be operated in the following languages:

- Via "FieldCare" operating tool:
English, German, French, Spanish, Italian, Chinese, Japanese
- Via Web browser
English, German, French, Spanish, Italian, Dutch, Portuguese, Polish, Russian, Turkish, Chinese, Japanese, Bahasa (Indonesian), Vietnamese, Czech

16.12 Certificates and approvals

CE mark

The measuring system is in conformity with the statutory requirements of the applicable EC Directives. These are listed in the corresponding EC Declaration of Conformity along with the standards applied.

Endress+Hauser confirms successful testing of the device by affixing to it the CE mark.

C-Tick symbol

The measuring system meets the EMC requirements of the "Australian Communications and Media Authority (ACMA)".

Ex approval

The devices are certified for use in hazardous areas and the relevant safety instructions are provided in the separate "Safety Instructions" (XA) document. Reference is made to this document on the nameplate.

Sanitary compatibility

- 3A approval and EHEDG-certified
- Seals → conform to FDA (apart from Kalrez seals)

Pressure Equipment Directive

- With the PED/G1/x (x = category) marking on the sensor nameplate, Endress+Hauser confirms compliance with the "Essential Safety Requirements" specified in Annex I of the Pressure Equipment Directive 97/23/EC.
- Devices not bearing this marking (PED) are designed and manufactured according to good engineering practice. They meet the requirements of Art.3 Section 3 of the Pressure Equipment Directive 97/23/EC. The range of application is indicated in tables 6 to 9 in Annex II of the Pressure Equipment Directive.

Other standards and guidelines

- EN 60529
Degrees of protection provided by enclosures (IP code)
- EN 61010-1
Safety requirements for electrical equipment for measurement, control and laboratory use
- IEC/EN 61326
Emission in accordance with Class A requirements. Electromagnetic compatibility (EMC requirements).
- NAMUR NE 21
Electromagnetic compatibility (EMC) of industrial process and laboratory control equipment
- NAMUR NE 32
Data retention in the event of a power failure in field and control instruments with microprocessors
- NAMUR NE 43
Standardization of the signal level for the breakdown information of digital transmitters with analog output signal.
- NAMUR NE 53
Software of field devices and signal-processing devices with digital electronics
- NAMUR NE 105
Specifications for integrating fieldbus devices in engineering tools for field devices
- NAMUR NE 107
Self-monitoring and diagnosis of field devices
- NAMUR NE 131
Requirements for field devices for standard applications

16.13 Application packages

Many different application packages are available to enhance the functionality of the device. Such packages might be needed to address safety aspects or specific application requirements.

The application packages can be ordered from Endress+Hauser either directly with the device or subsequently. Detailed information on the order code in question is available from your local Endress+Hauser sales center or on the product page of the Endress+Hauser website: www.endress.com.



Cleaning

Package	Description
Electrode cleaning circuit (ECC)	The electrode cleaning circuit (ECC) function has been developed to have a solution for applications where magnetite (Fe ₃ O ₄) deposits frequently occur (e.g. hot water). Since magnetite is highly conductive this build up leads to measuring errors and ultimately to the loss of signal. The application package is designed to AVOID build up of highly conductive matter and thin layers (typical of magnetite).

Heartbeat Technology

Package	Description
Heartbeat Verification +Monitoring	<p>Heartbeat Monitoring: Continuously supplies monitoring data, which are characteristic of the measuring principle, for an external condition monitoring system. This makes it possible to:</p> <ul style="list-style-type: none"> ▪ Draw conclusions - using these data and other information - about the impact the measuring application has on the measuring performance over time. ▪ Schedule servicing in time. ▪ Monitor the product quality, e.g. gas pockets. <p>Heartbeat Verification: Makes it possible to check the device functionality on demand when the device is installed, without having to interrupt the process.</p> <ul style="list-style-type: none"> ▪ Access via onsite operation or other operating interfaces, such as FieldCare for instance. ▪ Documentation of device functionality within the framework of manufacturer specifications, for proof testing for instance. ▪ End-to-end, traceable documentation of the verification results, including report. ▪ Makes it possible to extend calibration intervals in accordance with operator's risk assessment.

16.14 Accessories

 Overview of accessories available for order (→  90)

16.15 Supplementary documentation

-  For an overview of the scope of the associated Technical Documentation, refer to the following:
- The CD-ROM provided for the device (depending on the device version, the CD-ROM might not be part of the delivery!)
 - The *W@M Device Viewer* : Enter the serial number from the nameplate (www.endress.com/deviceviewer)
 - The *Endress+Hauser Operations App*: Enter the serial number from the nameplate or scan the 2-D matrix code (QR code) on the nameplate.

Standard documentation

Brief Operating Instructions

Measuring device	Documentation code
Promag H 100	KA01142D

Technical Information

Measuring device	Documentation code
Promag H 100	TI01101D

Supplementary device-dependent documentation



Safety Instructions

Contents	Documentation code
ATEX/IECEX Ex nA	XA01090D

Special Documentation

Contents	Documentation code
Heartbeat Technology	SD01149D

Installation Instructions

Contents	Documentation code
Installation Instructions for spare part sets	 Overview of accessories available for order (→  90)

17 Appendix

17.1 Overview of the operating menu

The following tables provide an overview of the entire operating menu structure with menus and parameters. The page reference indicates where a description of the parameter can be found in the manual.

* = The submenu only appears if it has been additionally ordered ("Technical Information", Section "Application packages").



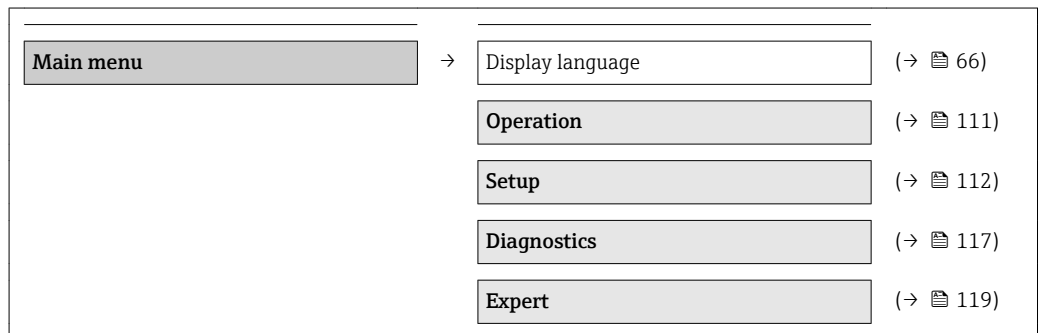



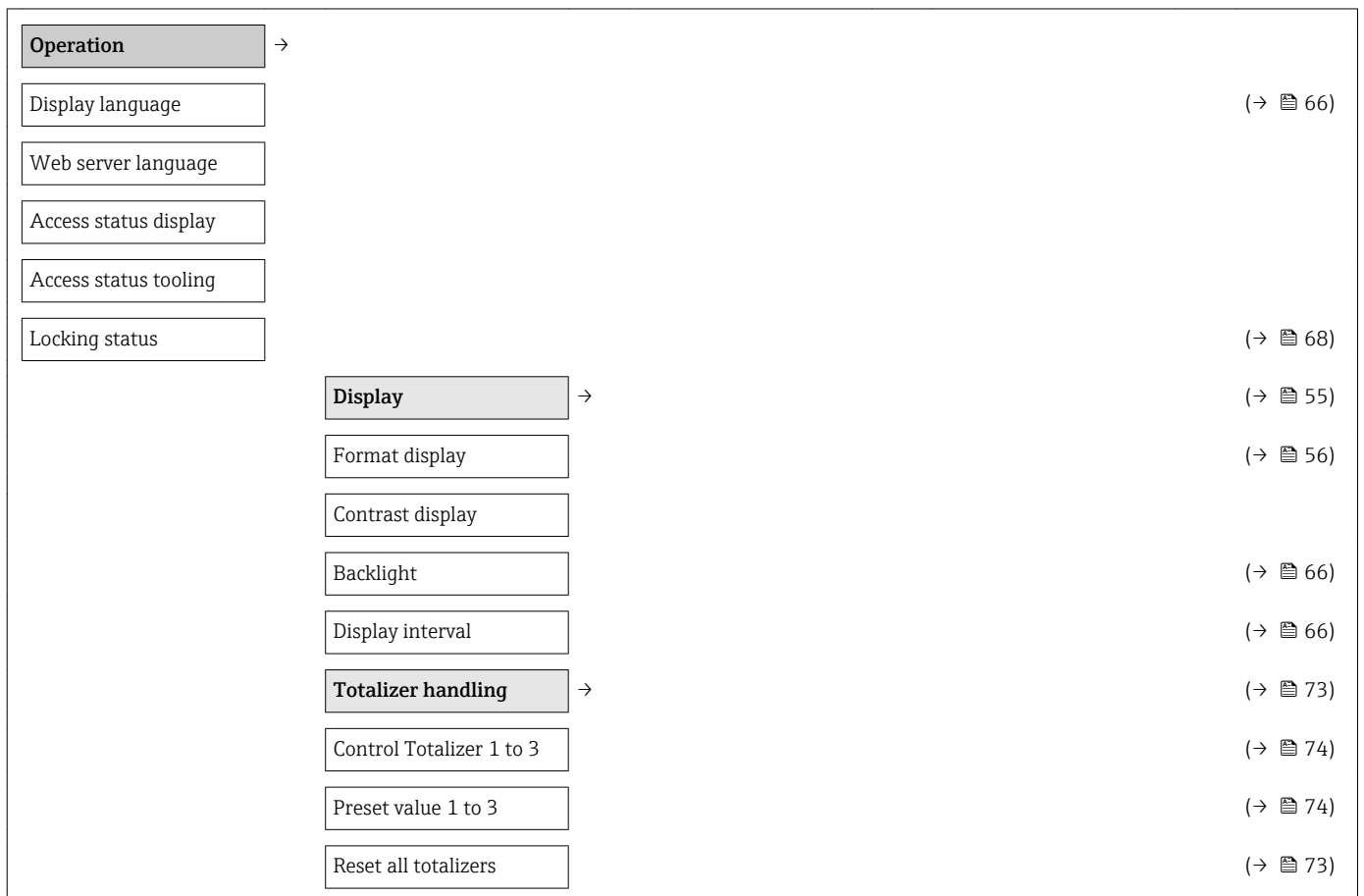





















17.1.1 Main menu



















































17.1.2 "Operation" menu



17.1.3 "Setup" menu

Setup →	(→  49)
Device tag	(→  49)
Current output 1 →	
Assign current output	(→  50)
Mass flow unit	(→  50)
Volume flow unit	(→  50)
Conductivity unit	(→  62)
Density unit	(→  62)
Current span	(→  50)
0/4 mA value	(→  50)
20 mA value	(→  50)
20 mA value	(→  50)
0/4 mA value	(→  50)
Failure mode	(→  51)
Failure current	(→  51)
Pulse/frequency/switch output →	(→  51)
Operating mode	(→  51)
Assign pulse output	(→  51)
Assign frequency output	(→  52)
Switch output function	(→  54)
Assign diagnostic behavior	(→  54)
Assign limit	(→  54)
Assign flow direction check	(→  54)
Assign status	(→  54)
Mass flow unit	(→  50)
Mass unit	(→  51)
Volume flow unit	(→  50)
Conductivity unit	(→  62)
Volume unit	(→  51)

Density unit		(→  62)
Unit totalizer		(→  54)
Unit totalizer		(→  54)
Unit totalizer		(→  54)
Value per pulse		(→  51)
Pulse width		(→  51)
Failure mode		(→  52)
Minimum frequency value		(→  53)
Maximum frequency value		(→  53)
Maximum frequency value		(→  53)
Minimum frequency value		(→  53)
Measuring value at minimum frequency		(→  53)
Measuring value at maximum frequency		(→  53)
Measuring value at maximum frequency		(→  53)
Measuring value at minimum frequency		(→  53)
Failure mode		(→  53)
Failure frequency		(→  53)
Switch-on value		(→  54)
Switch-off value		(→  54)
Switch-off value		(→  54)
Switch-on value		(→  54)
Switch-on delay		(→  54)
Switch-off delay		(→  54)
Failure mode		(→  54)
Invert output signal		(→  52)
Display	→	(→  55)
Format display		(→  56)
Value 1 display		(→  56)

0% bargraph value 1		(→  56)
100% bargraph value 1		(→  56)
Value 2 display		(→  56)
Value 3 display		(→  56)
0% bargraph value 3		(→  56)
100% bargraph value 3		(→  56)
Value 4 display		(→  56)
Output conditioning	→	(→  57)
Assign current output		(→  50)
Damping output 1		(→  58)
Measuring mode output 1		(→  58)
Assign frequency output		(→  52)
Damping output 1		(→  58)
Measuring mode output 1		(→  58)
Assign pulse output		(→  51)
Measuring mode output 1		(→  58)
Low flow cut off	→	
Assign process variable		(→  59)
On value low flow cutoff		(→  59)
Off value low flow cutoff		(→  59)
Pressure shock suppression		(→  59)
Empty pipe detection	→	(→  60)
Empty pipe detection		(→  60)
New adjustment		(→  60)
Progress		(→  60)
Switch point empty pipe detection		(→  60)
Response time part. filled pipe detect.		(→  60)
HART input	→	(→  56)
Capture mode		(→  57)













Device ID		(→ 57)
Device type		(→ 57)
Manufacturer ID		(→ 57)
Burst command		(→ 57)
Slot number		(→ 57)
Timeout		(→ 57)
Failure mode		(→ 57)
Failure value		(→ 57)
Advanced setup	→	(→ 61)
Enter access code		(→ 69)
	System units	→ (→ 61)
	Volume flow unit	(→ 50)
	Volume unit	(→ 51)
	Conductivity unit	(→ 62)
	Temperature unit	(→ 62)
	Mass flow unit	(→ 50)
	Mass unit	(→ 51)
	Density unit	(→ 62)
	Corrected volume flow unit	(→ 62)
	Corrected volume unit	(→ 62)
	Sensor adjustment	→ (→ 62)
	Installation direction	(→ 63)
	Totalizer 1 to 3	→ (→ 63)
	Assign process variable	(→ 63)
	Unit totalizer	(→ 54)
	Totalizer operation mode	(→ 63)
	Failure mode	(→ 63)
	Display	→ (→ 64)
	Format display	(→ 56)
	Value 1 display	(→ 56)
	0% bargraph value 1	(→ 56)

100% bargraph value 1		(→ 56)
Decimal places 1		(→ 65)
Value 2 display		(→ 56)
Decimal places 2		(→ 65)
Value 3 display		(→ 56)
0% bargraph value 3		(→ 56)
100% bargraph value 3		(→ 56)
Decimal places 3		(→ 65)
Value 4 display		(→ 56)
Decimal places 4		(→ 65)
Display language		(→ 66)
Display interval		(→ 66)
Display damping		(→ 66)
Header		(→ 66)
Header text		(→ 66)
Separator		(→ 66)
Backlight		(→ 66)
Electrode cleaning circuit ¹⁾	→	(→ 66)
Electrode cleaning circuit		(→ 67)
ECC duration		(→ 67)
ECC recovery time		(→ 67)
ECC cleaning cycle		(→ 67)
ECC Polarity		(→ 67)
Administration	→	
	Define access code	→ (→ 69)
	Define access code	(→ 69)
	Confirm access code	(→ 69)
Device reset		(→ 84)

1) Order code for "Application package", option EC "ECC electrode cleaning"

17.1.4 "Diagnostics" menu

Diagnostics →	(→ 📖 75)
Actual diagnostics	(→ 📖 82)
Previous diagnostics	(→ 📖 82)
Operating time from restart	(→ 📖 82)
Operating time	(→ 📖 0)
Diagnostic list →	(→ 📖 82)
Diagnostics 1 to 5	(→ 📖 82)
Event logbook →	(→ 📖 82)
Filter options	(→ 📖 83)
Device information →	(→ 📖 84)
Device tag	(→ 📖 85)
Serial number	(→ 📖 85)
Firmware version	(→ 📖 85)
Device name	(→ 📖 85)
Order code	(→ 📖 85)
Extended order code 1 to 3	(→ 📖 85)
ENP version	(→ 📖 85)
Device revision	(→ 📖 85)
Device ID	(→ 📖 85)
Device type	(→ 📖 85)
Manufacturer ID	(→ 📖 85)
IP address	(→ 📖 85)
Subnet mask	(→ 📖 85)
Default gateway	(→ 📖 85)
Measured values →	
Process variables →	(→ 📖 71)
Volume flow	(→ 📖 71)
Mass flow	(→ 📖 71)
Conductivity	(→ 📖 72)

	Corrected volume flow	(→  72)
	Temperature	(→  72)
	Corrected conductivity	(→  72)
	Totalizer 1 to 3 →	(→  72)
	Totalizer value 1 to 3	(→  72)
	Totalizer overflow 1 to 3	(→  72)
	Output values →	(→  72)
	Output current 1	(→  73)
	Measured current 1	(→  73)
	Pulse output 1	(→  73)
	Output frequency 1	(→  73)
	Switch status 1	(→  73)
	Heartbeat¹⁾ →	(→  109)
	Performing verification →	
	Year	
	Month	
	Day	
	Hour	
	AM/PM	
	Minute	
	External device information	
	Start verification	
	Progress	
	Status	
	Overall result	
	Verification results →	
	Date/time	
	Verification ID	
	Operating time	
	Overall result	
	Sensor	

	Sensor electronic module	
	I/O module	
	Monitoring results	→
	Noise	
	Coil current shot time	
	Reference electrode potential against PE	
Simulation		→ (→ 67)
	Assign simulation process variable	→ (→ 68)
	Value process variable	→ (→ 68)
	Simulation current output 1	→ (→ 68)
	Value current output 1	→ (→ 68)
	Frequency simulation	→ (→ 68)
	Frequency value	→ (→ 68)
	Pulse simulation	→ (→ 68)
	Pulse value	→ (→ 68)
	Switch output simulation	→ (→ 68)
	Switch status	→ (→ 68)
	Simulation device alarm	→ (→ 68)
	Simulation diagnostic event	→ (→ 68)

1) Order code for "Application package", option EB "Heartbeat Verification + Monitoring", see the Special Documentation for the device

17.1.5 "Expert" menu

The following tables provide an overview of the **Expert** menu (→ 119) with its submenus and parameters. The direct access code to the parameter is given in brackets. The page reference indicates where a description of the parameter can be found in the manual.





Overview "Expert" menu

Expert	→	(→ 36)
Direct access (0106)		
Locking status (0004)		(→ 71)
Access status display (0091)		

Access status tooling (0005)	(→ 📖 69)
Enter access code (0092)	
System	(→ 📖 120)
Sensor	(→ 📖 121)
Output	(→ 📖 125)
Communication	(→ 📖 127)
Application	(→ 📖 128)
Diagnostics	(→ 📖 129)



























"System" submenu











System	→	
Display	→	(→ 📖 64)
Display language (0104)		(→ 📖 66)
Format display (0098)		(→ 📖 56)
Value 1 display (0107)		(→ 📖 56)
0% bargraph value 1 (0123)		(→ 📖 56)
100% bargraph value 1 (0125)		(→ 📖 56)
Decimal places 1 (0095)		(→ 📖 65)
Value 2 display (0108)		(→ 📖 56)
Decimal places 2 (0117)		(→ 📖 65)
Value 3 display (0110)		(→ 📖 56)
0% bargraph value 3 (0124)		(→ 📖 56)
100% bargraph value 3 (0126)		(→ 📖 56)
Value 4 display (0109)		(→ 📖 56)
Decimal places 4 (0119)		(→ 📖 65)
Display interval (0096)		(→ 📖 66)
Display damping (0094)		(→ 📖 66)
Header (0097)		(→ 📖 66)
Header text (0112)		(→ 📖 66)

Separator (0101)		(→  66)
Contrast display (0105)		
Backlight (0111)		(→  66)
Access status display (0091)		
Diagnostic handling	→	(→  75)
Alarm delay (0651)		
	Diagnostic behavior	→
	Assign behavior of diagnostic no. 531 (0741)	
	Assign behavior of diagnostic no. 832 (0681)	
	Assign behavior of diagnostic no. 833 (0682)	
	Assign behavior of diagnostic no. 834 (0700)	
	Assign behavior of diagnostic no. 835 (0702)	
	Assign behavior of diagnostic no. 862 (0745)	
	Assign behavior of diagnostic no. 937 (0743)	
	Assign behavior of diagnostic no. 302 (0739)	
	Administration	→
	Define access code (0093)	(→  69)
Device reset (0000)		(→  84)
Activate SW option (0029)		
Software option overview (0015)		

"Sensor" submenu

Sensor	→	
---------------	---	--

Measured values	→	(→  71)
Process variables	→	(→  71)
Volume flow (1847)		(→  71)
Mass flow (1838)		(→  71)
Conductivity (1850)		(→  72)
Corrected volume flow (1851)		(→  72)
Temperature (1853)		(→  72)
Corrected conductivity (1853)		(→  72)
Totalizer 1 to 3	→	(→  72)
Totalizer value 1 to 3 (0911-1 to 3)		(→  72)
Totalizer overflow 1 to 3 (0910-1 to 3)		(→  72)
Output values	→	(→  72)
Output current 1 (0361)		(→  73)
Measured current 1 (0366)		(→  73)
Pulse output 1 (0456)		(→  73)
Output frequency 1 (0471)		(→  73)
Switch status 1 (0461)		(→  73)
System units	→	(→  61)
Volume flow unit (0553)		(→  50)
Volume unit (0563)		(→  51)
Conductivity unit (0582)		(→  62)
Temperature unit (0557)		(→  62)
Mass flow unit (0554)		(→  50)
Mass unit (0574)		(→  51)
Density unit (0555)		(→  62)
Corrected volume flow unit (0558)		(→  62)
Corrected volume unit (0575)		(→  62)
Date/time format (2812)		

User-specific units	→	
		User volume text (0567)
		User volume offset (0569)
		User volume factor
		User mass text
		User mass offset (0562)
		User mass factor (0561)
Process parameters	→	(→  49)
		Filter options (6710)
		Flow damping (6661)
		Flow override (1839)
		Conductivity damping (1803)
		Temperature damping (1886)
		Conductivity measurement (6514)
		Low flow cut off
		→
		Assign process variable (1837)
		(→  59)
		On value low flow cutoff (1805)
		(→  59)
		Off value low flow cutoff (1804)
		(→  59)
		Pressure shock suppression (1806)
		(→  59)
		Empty pipe detection
		→
		Empty pipe detection (1860)
		(→  60)
		Switch point empty pipe detection (6562)
		(→  60)
		Response time part. filled pipe detect. (1859)
		(→  60)
		New adjustment (6560)
		(→  60)
		Progress (6571)
		(→  60)
		Empty pipe adjust value (6527)

	Full pipe adjust value (6548)	
	Measured value EPD (6559)	
	Electrode cleaning circuit¹⁾	→ ⓘ 66
	Electrode cleaning circuit (6528)	→ ⓘ 67
	ECC duration (6555)	→ ⓘ 67
	ECC recovery time (6556)	→ ⓘ 67
	ECC cleaning cycle (6557)	→ ⓘ 67
	ECC Polarity (6631)	→ ⓘ 67
External compensation	→	
External value (6707)		
External temperature (6673)		
External density (6630)		
Fixed density (6623)		
Reference density (1885)		
Sensor adjustment	→	
Installation direction (1809)		→ ⓘ 63
Integration time (6533)		
Measuring period (6536)		
	Process variable adjustment	→
	Volume flow offset (1841)	
	Volume flow factor (1846)	
	Mass flow offset (1831)	
	Mass flow factor (1832)	
	Conductivity offset (1848)	
	Conductivity factor (1849)	

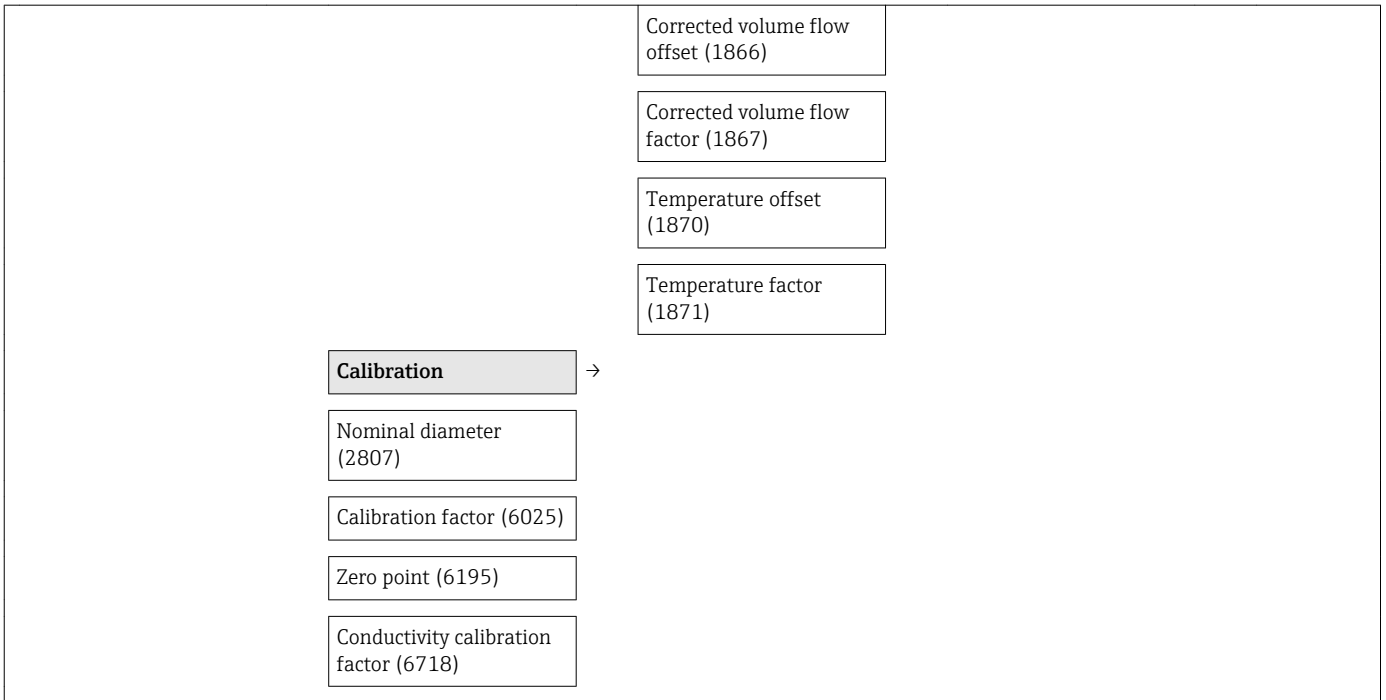

1) Order code for "Application package", option EC "ECC electrode cleaning"









































"Output" submenu



Assign pulse output (0460)	(→  51)
Value per pulse (0455)	(→  51)
Pulse width (0452)	(→  51)
Measuring mode (0351)	
Failure mode (0480)	(→  52)
Pulse output 1 (0456)	(→  73)
Assign frequency output (0478)	(→  52)
Minimum frequency value (0453)	(→  53)
Maximum frequency value (0454)	(→  53)
Measuring value at minimum frequency (0476)	(→  53)
Measuring value at maximum frequency (0475)	(→  53)
Measuring mode (0479)	
Damping output	
Response time (0491)	
Failure mode (0451)	(→  53)
Failure frequency (0474)	(→  53)
Output frequency 1 (0471)	(→  73)
Switch output function (0481)	(→  54)
Assign diagnostic behavior (0482)	(→  54)
Assign limit (0483)	(→  54)
Switch-on value (0466)	(→  54)
Switch-off value (0464)	(→  54)
Assign flow direction check (0484)	(→  54)
Assign status (0485)	(→  54)
Switch-on delay (0467)	(→  54)
Switch-off delay (0465)	(→  54)

Failure mode (0486)	(→  54)
Switch status 1 (0461)	(→  73)
Invert output signal (0470)	(→  52)



"Communication" submenu

Communication →																											
	HART input → (→  56)																										
	<table border="1"> <tr> <td>Configuration →</td> <td></td> </tr> <tr> <td>Capture mode (7001)</td> <td>(→  57)</td> </tr> <tr> <td>Device ID (7007)</td> <td>(→  57)</td> </tr> <tr> <td>Device type (7008)</td> <td>(→  57)</td> </tr> <tr> <td>Manufacturer ID (7009)</td> <td>(→  57)</td> </tr> <tr> <td>Burst command (7006)</td> <td>(→  57)</td> </tr> <tr> <td>Slot number (7010)</td> <td>(→  57)</td> </tr> <tr> <td>Timeout (7005)</td> <td>(→  57)</td> </tr> <tr> <td>Failure mode (7011)</td> <td>(→  57)</td> </tr> <tr> <td>Failure value (7012)</td> <td>(→  57)</td> </tr> <tr> <td>Input</td> <td></td> </tr> <tr> <td>Value (7003)</td> <td></td> </tr> <tr> <td>Status (7004)</td> <td></td> </tr> </table>	Configuration →		Capture mode (7001)	(→  57)	Device ID (7007)	(→  57)	Device type (7008)	(→  57)	Manufacturer ID (7009)	(→  57)	Burst command (7006)	(→  57)	Slot number (7010)	(→  57)	Timeout (7005)	(→  57)	Failure mode (7011)	(→  57)	Failure value (7012)	(→  57)	Input		Value (7003)		Status (7004)	
Configuration →																											
Capture mode (7001)	(→  57)																										
Device ID (7007)	(→  57)																										
Device type (7008)	(→  57)																										
Manufacturer ID (7009)	(→  57)																										
Burst command (7006)	(→  57)																										
Slot number (7010)	(→  57)																										
Timeout (7005)	(→  57)																										
Failure mode (7011)	(→  57)																										
Failure value (7012)	(→  57)																										
Input																											
Value (7003)																											
Status (7004)																											
	HART output → (→  45)																										
	<table border="1"> <tr> <td>Configuration →</td> <td></td> </tr> <tr> <td>Burst mode (0208)</td> <td></td> </tr> <tr> <td>Burst command (0207)</td> <td></td> </tr> <tr> <td>HART address (0219)</td> <td></td> </tr> <tr> <td>No. of preambles (0217)</td> <td></td> </tr> <tr> <td>HART short tag (0220)</td> <td></td> </tr> <tr> <td>Information →</td> <td>(→  84)</td> </tr> <tr> <td>Device revision (0204)</td> <td>(→  85)</td> </tr> <tr> <td>Device ID (0221)</td> <td>(→  85)</td> </tr> <tr> <td>Device type (0222)</td> <td>(→  85)</td> </tr> </table>	Configuration →		Burst mode (0208)		Burst command (0207)		HART address (0219)		No. of preambles (0217)		HART short tag (0220)		Information →	(→  84)	Device revision (0204)	(→  85)	Device ID (0221)	(→  85)	Device type (0222)	(→  85)						
Configuration →																											
Burst mode (0208)																											
Burst command (0207)																											
HART address (0219)																											
No. of preambles (0217)																											
HART short tag (0220)																											
Information →	(→  84)																										
Device revision (0204)	(→  85)																										
Device ID (0221)	(→  85)																										
Device type (0222)	(→  85)																										

	Manufacturer ID (0223)	(→ ⓘ 85)
	HART revision (0205)	(→ ⓘ 45)
	HART descriptor (0212)	
	HART message (0216)	
	Hardware revision (0206)	
	Software revision (0224)	
	HART date code (0202)	
	Output →	(→ ⓘ 45)
	Assign PV (0234)	
	Primary variable (PV) (0201)	
	Assign SV (0235)	
	Secondary variable (SV) (0226)	
	Assign TV (0236)	
	Tertiary variable (TV) (0228)	
	Assign QV (0237)	
	Quaternary variable (QV) (0203)	
	Web server →	(→ ⓘ 36)
	Web server language (7221)	
	MAC address (7214)	
	IP address (7209)	
	Subnet mask (7211)	
	Default gateway (7210)	
	Web server functionality (7222)	(→ ⓘ 39)









"Application" submenu

Application →		
Reset all totalizers (2806)		(→ ⓘ 74)
Totalizer 1 to 3 →		(→ ⓘ 63)





Assign process variable (0914)	(→  63)
Unit totalizer (0915)	(→  54)
Totalizer operation mode	(→  63)
Control Totalizer 1 to 3 (0912-1 to 3)	(→  74)
Preset value 1 to 3 (0913-1 to 3)	(→  74)
Failure mode (0901)	(→  63)
Concentration →	
Concentration unit	
User concentration text	
User concentration factor	
User concentration offset	
A 0	
A 1 to 4	
B 1 to 3	

"Diagnostics" submenu

Diagnostics →	(→  75)
Actual diagnostics (0691)	(→  82)
Timestamp (0667)	
Previous diagnostics (0690)	(→  82)
Timestamp (0672)	
Operating time from restart (0653)	(→  82)
Operating time (0652)	(→  82)
Diagnostic list →	(→  82)
Diagnostics 1 to 5 (0692-1 to 5)	(→  82)
Timestamp 1 to 5 (0683-1 to 5)	
Event logbook →	(→  82)
Filter options (0705)	(→  83)

Device information	→		(→  84)
Device tag (0011)			(→  85)
Serial number (0009)			(→  85)
Firmware version (0010)			(→  85)
Device name (0013)			(→  85)
Order code (0008)			(→  85)
Extended order code 1 to 3 (0023-1 to 3)			(→  85)
Configuration counter (0233)			
ENP version (0012)			(→  85)
Min/max values	→		
Reset min/max values (6151)			
		Main electronic temperature	→
		Minimum value (6547)	
		Maximum value (6545)	
		Temperature	→
		Minimum value (6030)	
		Maximum value (6029)	
Heartbeat¹⁾	→		(→  109)
		Heartbeat base settings	→
		Plant operator (2754)	
		Location (2751)	
		Performing verification	→
		Year (2846)	
		Month (2845)	
		Day (2842)	
		Hour (2843)	
		AM/PM (2813)	
		Minute (2844)	
		External device information (12101)	

	Start verification (12127)	
	Progress (2808)	
	Status (12153)	
	Overall result (12149)	
	Verification results →	
	Date/time (12142)	
	Verification ID (12141)	
	Operating time (12126)	
	Overall result (12149)	
	Sensor (12152)	
	Sensor electronic module (12151)	
	I/O module (12145)	
	Monitoring results →	
	Noise (12158)	
	Coil current shot time (12150)	
	Reference electrode potential against PE (12155)	
Simulation →		(→ 📄 67)
	Assign simulation process variable (1810)	(→ 📄 68)
	Value process variable (1811)	(→ 📄 68)
	Simulation current output 1 (0354)	(→ 📄 68)
	Value current output 1 (0355)	(→ 📄 68)
	Frequency simulation (0472-1 to #)	(→ 📄 68)
	Frequency value (0473-1 to #)	(→ 📄 68)
	Pulse simulation (0458-1 to #)	(→ 📄 68)
	Pulse value (0459-1 to #)	(→ 📄 68)

	Switch output simulation (0462-1 to #)	(→  68)
	Switch status (0463-1 to #)	(→  68)
	Simulation device alarm (0654)	(→  68)
	Simulation diagnostic event (0737)	(→  68)

- 1) Order code for "Application package", option EB "Heartbeat Verification + Monitoring", see the Special Documentation for the device

Index

A

Adapters	21
Adapting the diagnostic behavior	78
Adapting the status signal	78
Ambient temperature	
Influence	100
Ambient temperature range	19
AMS Device Manager	43
Function	43
Application	8, 93
Applicator	93
Approvals	107

C

C-Tick symbol	107
Cable entries	
Technical data	98
Cable entry	
Degree of protection	33
CE mark	9, 107
Certificates	107
Checklist	
Post-connection check	33
Post-installation check	25
Cleaning	
Exterior cleaning	87
Interior cleaning	87
Cleaning in place (CIP)	100
Commissioning	49
Advanced settings	61
Configuring the measuring device	49
Communication-specific data	45
Conductivity	101
Connecting cable	27
Connecting the measuring device	29
Connection	
see Electrical connection	
Connection examples, potential equalization	31
Connection preparations	29
Connection tools	27
Current consumption	98

D

Declaration of Conformity	9
Define access code	69
Degree of protection	33, 100
Design	
Measuring device	11
Designated use	8
Device components	11
Device description files	45
Device documentation	
Supplementary documentation	7
Device locking, status	71
Device name	
Sensor	14

Transmitter	13
Device repair	88
Device revision	45
Device type ID	45
Diagnostic information	
Design, description	77
FieldCare	76
Light emitting diodes	76
Overview	78
Remedial measures	78
Diagnostic list	82
DIP switch	
see Write protection switch	
Disabling write protection	68
Display	
Current diagnostic event	81
Previous diagnostic event	81
Display values	
For locking status	71
Disposal	88
Document	
Function	5
Symbols used	5
Document function	5
Down pipe	17

E

ECC	66
Electrical connection	
Commubox FXA195	40, 106
Degree of protection	33
Field Communicator	40, 106
Handheld terminals	40, 106
Measuring device	27
Operating tools	40, 106
Via HART protocol	40, 106
Via service interface (CDI-RJ45)	41
Web server	41
Electromagnetic compatibility	100
Enabling write protection	68
Endress+Hauser services	
Maintenance	87
Repair	88
Environment	
Ambient temperature range	19
Mechanical load	100
Shock resistance	100
Storage temperature	100
Vibration resistance	100
Error messages	
see Diagnostic messages	
Event history	82
Events list	82
Ex approval	107
Extended order code	
Sensor	14

- Transmitter 13
- Exterior cleaning 87
- F**
- Field Communicator
 - Function 44
- Field Communicator 475 44
- Field of application
 - Residual risks 9
- Field Xpert
 - Function 41
- Field Xpert SFX350 41
- FieldCare 41
 - Device description file 45
 - Establishing a connection 42
 - Function 41
 - User interface 43
- Filtering the event logbook 83
- Firmware
 - Release date 45
 - Version 45
- Firmware history 86
- Fitted electrodes 105
- Flow direction 18
- Flow limit 101
- Function check 49
- Function scope
 - AMS Device Manager 43
 - Field Communicator 44
 - Field Communicator 475 44
 - Field Xpert 41
 - SIMATIC PDM 43
- Functions
 - see Parameter
- G**
- Galvanic isolation 97
- H**
- Hardware write protection 69
- HART input
 - Settings 56
- HART protocol
 - Device variables 45
 - Measured variables 45
- I**
- I/O electronics module 11, 29
- Identifying the measuring device 12
- Incoming acceptance 12
- Influence
 - Ambient temperature 100
- Information on the document 5
- Inlet runs 19
- Input 93
- Inspection
 - Installation 25
 - Received goods 12
- Inspection check
 - Connection 33
- Installation conditions
 - Adapters 21
 - Down pipe 17
 - Inlet and outlet runs 19
 - Mounting location 17
 - Orientation 18
 - Partially filled pipe 18
 - System pressure 20
 - Vibrations 20
- Installation dimensions 19
- Interior cleaning 87, 100
- L**
- Languages, operation options 107
- Low flow cut off 97
- M**
- Main electronics module 11
- Maintenance tasks 87
 - Replacing seals 87
- Manufacturer ID 45
- Manufacturing date 13, 14
- Materials 103
- Maximum measured error 98
- Measured variables
 - Calculated 93
 - Measured 93
 - see Process variables
- Measuring and test equipment 87
- Measuring device
 - Configuration 49
 - Conversion 88
 - Design 11
 - Disposal 89
 - Integrating via HART protocol 45
 - Mounting the sensor 22
 - Cleaning with pigs 23
 - Mounting grounding rings 23
 - Mounting the seals 23
 - Welding connections 22
 - Preparing for electrical connection 29
 - Preparing for mounting 21
 - Removing 88
 - Repair 88
- Measuring principle 93
- Measuring range 93
- Measuring system 93
- Measuring tube specification 102
- Mechanical load 100
- Media 8
- Medium temperature range 101
- menu
 - Diagnostics 81
 - Operation 71
 - Setup 49
- Menus
 - For measuring device configuration 49
 - For specific settings 61
- Mounting 17

- Mounting dimensions
 - see Installation dimensions
- Mounting location 17
- Mounting preparations 21
- Mounting requirements
 - Installation dimensions 19
- Mounting tools 21
- N**
- Nameplate
 - Sensor 14
 - Transmitter 13
- O**
- Operable flow range 94
- Operating menu
 - Menus, submenus 35
 - Overview of menus with parameters 111
 - Structure 35
 - Submenus and user roles 36
- Operating philosophy 36
- Operation 71
- Operation options 34
- Operational safety 9
- Order code 13, 14
- Orientation (vertical, horizontal) 18
- Outlet runs 19
- Output 95
- Output signal 95
- Overview
 - Operating menu 111
- P**
- Packaging disposal 17
- Parameter settings
 - Burst configuration 1 to 3 (submenu) 47
 - Configuration (submenu) 56
 - Current output 1 to 2 (wizard) 50
 - Device information (submenu) 84
 - Diagnostics (menu) 81
 - Display (submenu) 64
 - Display (wizard) 55
 - Electrode cleaning circuit (submenu) 66
 - Empty pipe detection (wizard) 60
 - Low flow cut off (wizard) 58
 - Operation (submenu) 73
 - Output conditioning (wizard) 57
 - Output values (submenu) 72
 - Process variables (submenu) 71
 - Pulse/frequency/switch output (wizard) 51, 52, 53
 - Sensor adjustment (submenu) 62
 - Setup (menu) 49
 - Simulation (submenu) 67
 - System units (submenu) 61
 - Totalizer (submenu) 72
 - Totalizer 1 to 3 (submenu) 63
 - Web server (submenu) 39
- Partially filled pipe 18
- Performance characteristics 98
- Post-connection check (checklist) 33
- Post-installation check 49
- Post-installation check (checklist) 25
- Potential equalization 31, 98
- Power consumption 98
- Power supply failure 98
- Pressure Equipment Directive 108
- Pressure loss 102
- Pressure tightness 101
- Pressure-temperature ratings 101
- Process conditions
 - Conductivity 101
 - Flow limit 101
 - Medium temperature 101
 - Pressure loss 102
 - Pressure tightness 101
- Process connections 105
- Product safety 9
- Protecting parameter settings 68
- R**
- Reading measured values 71
- Recalibration 87
- Reference operating conditions 98
- Registered trademarks 7
- Remote operation 106
- Repair 88
 - Notes 88
- Repair of a device 88
- Repeatability 99
- Replacement
 - Device components 88
- Replacing seals 87
- Requirements for personnel 8
- Returning devices 88
- S**
- Safety 8
- Sanitary compatibility 107
- Sensor
 - Mounting 22
- Serial number 13, 14
- Service interface (CDI-RJ45) 106
- Settings
 - Adapting the measuring device to the process conditions 73
 - Advanced display configurations 64
 - Current output 50
 - Device reset 84
 - Device tag 49
 - Electrode cleaning circuit (ECC) 66
 - Empty pipe detection (EPD) 60
 - HART input 56
 - Local display 55
 - Low flow cut off 58
 - Output conditioning 57
 - Pulse/frequency/switch output 51
 - Resetting the totalizer 73
 - Sensor adjustment 62

Simulation	67	Transport	16
System units	61	Transmitter	
Totalizer	63	Connecting the signal cables	29
Totalizer reset	73	Turning the display module	24
Shock resistance	100	Transporting the measuring device	16
Signal on alarm	96	Troubleshooting	
SIMATIC PDM	43	General	75
Function	43	Turning the display module	24
Software release	45	U	
Spare part	88	Use of the measuring device	
Spare parts	88	Borderline cases	8
Special connection instructions	33	Incorrect use	8
Standards and guidelines	108	see Designated use	
Status signals	77	User roles	36
Sterilization in place (SIP)	100	V	
Storage conditions	16	Version data for the device	45
Storage temperature	16	Vibration resistance	100
Storage temperature range	100	Vibrations	20
Structure		W	
Operating menu	35	W@M	87, 88
submenu		W@M Device Viewer	12, 88
Burst configuration 1 to 3	47	Weight	
Configuration	56	Transport (notes)	16
Device information	84	wizard	
Display	64	Current output 1 to 2	50
Electrode cleaning circuit	66	Define access code	69
Operation	73	Display	55
Output values	72	Empty pipe detection	60
Process variables	71	Low flow cut off	58
Sensor adjustment	62	Output conditioning	57
Simulation	67	Pulse/frequency/switch output	51, 52, 53
System units	61	Workplace safety	9
Totalizer	72	Write protection	
Totalizer 1 to 3	63	Via access code	69
Web server	39	Via write protection switch	69
Submenu		Write protection switch	69
Define access code	69		
Events list	82		
Overview	36		
Process variables	71		
Supplementary documentation	109		
Supply voltage	97		
Surface roughness	105		
System design			
Measuring system	93		
see Measuring device design			
System integration	45		
System pressure	20		
T			
Technical data, overview	93		
Temperature measurement response time	99		
Temperature range			
Storage temperature	16		
Terminal assignment	28, 29		
Terminals	98		
Tools			
Electrical connection	27		
For mounting	21		

www.addresses.endress.com
