

Technical Information

WirelessHART Adapter SWA70

WirelessHART

Smart WirelessHART interface module with power supply for field devices



Application

The WirelessHART Adapter SWA70 is an interface module for the wireless transmission of 4 to 20 mA/HART signals from connected field devices to a WirelessHART Fieldgate. It is powered by either a battery pack or power supply units. The WirelessHART Adapter can be used in hazardous and non-hazardous area for applications, such as:

- Process optimization:
By connecting the WirelessHART Adapter, it is possible to monitor and optimize plant sections with less cost and effort.
- Level monitoring in tanks and silos:
Measured values together with the device and battery status are transmitted at regular intervals to a higher-level system.
- Plant condition monitoring:
Wireless devices are mounted at critical points in the plant which are not normally connected to the control room due to their limited accessibility or wiring costs. Improved data flow and diagnostics increase plant reliability and safety.

Your benefits

The flexible adapter concept offers the following advantages:

- HART devices are quickly upgraded to WirelessHART technology
- Fast integration of 4 to 20 mA field devices into a WirelessHART network
- One 4 to 20 mA field device and up to four HART field devices in multidrop mode can be connected to a WirelessHART Adapter
- Burst mode and event notification supported
- Remote and difficult-to-access HART devices are connected to the control room without expensive cabling
- Easy planning, quick installation and integration

Function and system design

WirelessHART

WirelessHART adds wireless capabilities to the HART protocol, while ensuring compatibility with existing HART devices, commands and tools.

A WirelessHART network comprises:

- Wireless field devices
- Wired field devices with a connected WirelessHART Adapter
- Gateways responsible for communication between devices and host applications
- Network and Safety Manager responsible for configuring, managing and monitoring the network

WirelessHART Adapter SWA70

The WirelessHART Adapter SWA70 acts as an add-on interface for wireless communication with HART field devices or 4 to 20 mA field devices.

It is powered by either a battery pack, a wide range power unit or a DC power unit. The DC power unit can use solar power, for example. A special long-life, high-power battery is used as the battery.

The WirelessHART Adapter SWA70 supports the following functions:

- Power supply for a HART field device or a 4 to 20 mA field device
- Power supply of up to four HART devices in the multidrop mode with a wide range power unit
- Connection of up to four externally powered HART field devices in the multidrop mode
- Scaling of the current signal from a connected 4 to 20 mA field device
- Burst mode and event notification for the WirelessHART Adapter and the connected field devices

System design

The WirelessHART Adapter SWA70 transmits information to a host application via a WirelessHART Fieldgate. The figure below shows a typical WirelessHART network architecture.

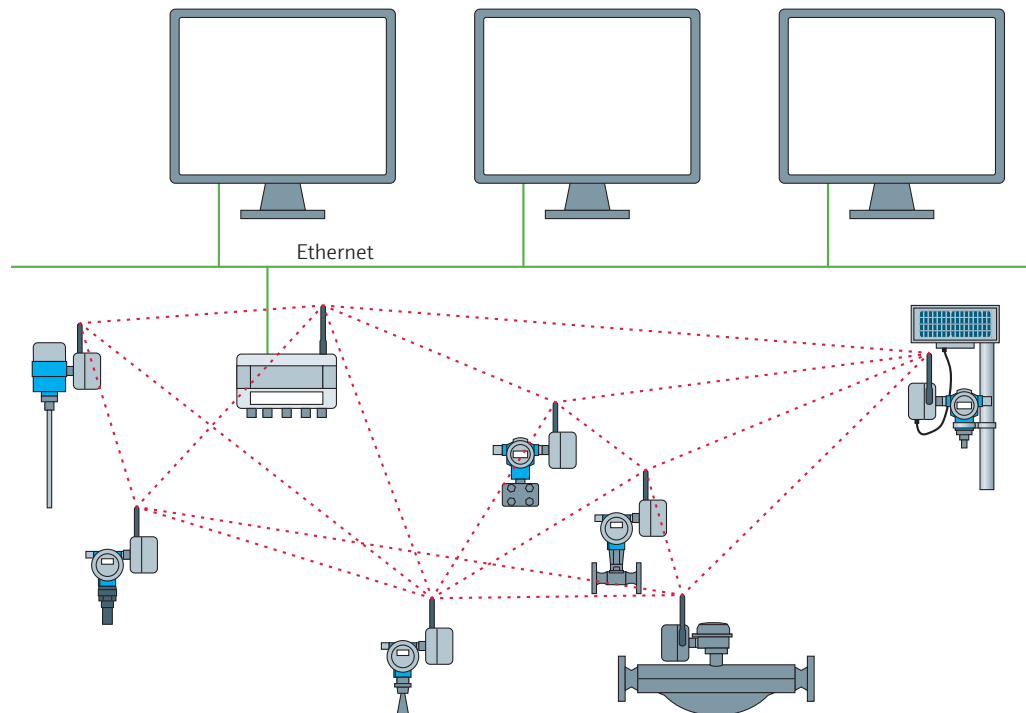

Inputs (wired interface)

Inputs

- One input channel for:
- One point-to-point connection with a HART field device or
 - One point-to-point connection with a 4-20 mA field device or
 - Up to four HART field devices connected in multidrop mode if a wide range power unit is used. The wide range power unit provides 24 V to power the field devices.

Communication interface

- HART interface to configure the WirelessHART Adapter with a HART modem
- LPI interface (internal interface for the manufacturing and diagnosis)

Protocol version

HART Version 7.3 (backwards compatible with earlier HART versions)

Transmission rate

1200 bits/s

Field device power supply

- Current: 4 to 20 mA (according to NAMUR recommendation NE 43) or 4 mA if only one field device is connected in multidrop mode
- Error current: $I \leq 3.6 \text{ mA}$ or $I \geq 21 \text{ mA}$
- Protection: Short-circuit protection, triggered if currents $> 25 \text{ mA}$
- Terminal voltage: 8 to 23 V DC, configurable

Connection of externally powered devices on terminals 2...6

max. permissible input current terminals 2...6: 100 mA
max. permissible input voltage terminals 2...6: 30 V DC

Only the connection of power supply units of the protection class II is permissible.

Terminals

The WirelessHART Adapter has a terminal block with screw terminals 1-6 and 2 eyelets 7 and 8 for connection purposes.

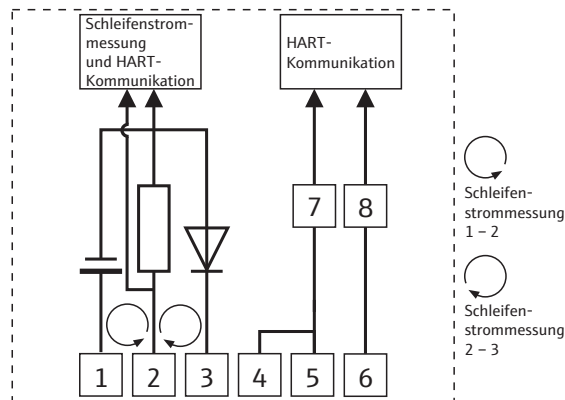

Application	Terminal assignment	Remarks	Connection values
Power supply to a loop-powered field device	1 (+) and 2 (-)	<ul style="list-style-type: none"> ▪ Current measurement and HART communication where applicable ▪ Loop current flows through the adapter 	<ul style="list-style-type: none"> ▪ 4 to 20 mA (according to NAMUR NE43) ▪ 8-23 V power supply for field device, configurable, see the following diagram ▪ Integrated load: 250 Ohm
Integration of the WirelessHART Adapter into a current loop	2 (+) and 3 (-)	<ul style="list-style-type: none"> ▪ Current measurement and HART communication where applicable ▪ Loop current flows through the adapter 	<ul style="list-style-type: none"> ▪ 4 to 20 mA (according to NAMUR NE43) ▪ Integrated load: 250 Ohm
Integration of the WirelessHART Adapter into a current loop	5 and 6	<ul style="list-style-type: none"> ▪ Integration into HART communication ▪ Loop current does not flow through the adapter 	<ul style="list-style-type: none"> ▪ Input impedance for HART communication: $> 10 \text{ kOhm}$ at 1700 Hz ▪ DC input impedance: 1 MOhm

Application	Terminal assignment	Remarks	Connection values
Configuration of the WirelessHART Adapter with a HART modem	7 and 8	Temporary connection of the modem via eyelets	<ul style="list-style-type: none"> ■ Input impedance for HART communication: > 10 kOhm at 1700 Hz ■ DC input impedance: > 1 MOhm

Field device power supply through SWA70

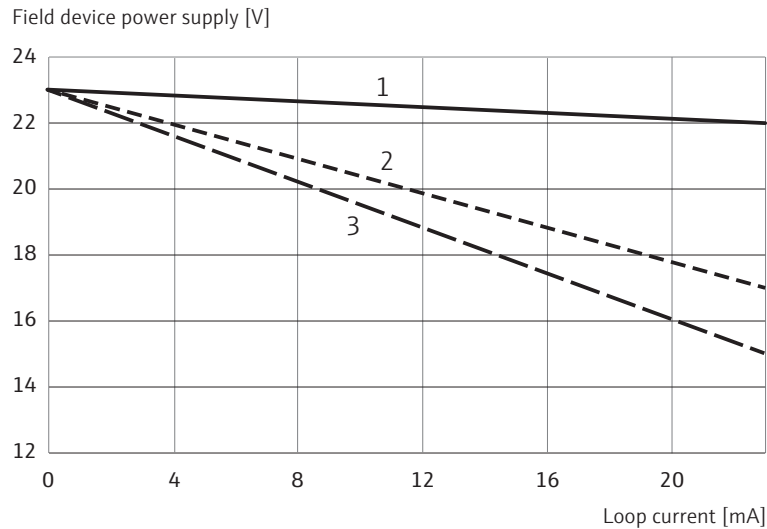

- 1 SWA70 non-Ex versions with 4 to 20 mA field device
- 2 SWA70 non-Ex versions with HART field device
- 3 SWA70 Ex versions with HART field device or 4 to 20 mA field device

Output (wireless interface)

Communication interface	WirelessHART communication interface (IEC 62591), HART version 7.3 (backwards compatible with earlier HART versions)
Transmission rate	Nominal 250 kBits/s
Operating frequency	2.4 GHz (ISM band)
Range	Up to 250 m outdoors, up to 50 m indoors
Transmission power	Can be configured for 0 dBm or 10 dBm to adapt to national regulations
Device variables	<p>Up to 10 bursts can be configured in accordance with the HART specification. Up to eight device variables per burst can be configured depending on user transmission requirements.</p> <p>Example:</p> <ul style="list-style-type: none"> ■ HART field device: device variables ■ 4 to 20 mA field device: scaled or linearized process values ■ WirelessHART Adapter: scaled loop current and other variables, choose from: estimated battery life, battery voltage, energy used, adapter temperature
Additional functions	<ul style="list-style-type: none"> ■ Event notification, configurable for up to eight variables from the WirelessHART adapter and/or connected field devices ■ Error notification and scaling or linearization of the 4 to 20 mA signal of the connected analog field device ■ Monitoring of energy consumption ■ Locking of device parameterization

Diagnostics Diagnostics function in accordance with NAMUR NE 107, ASM and HART recommendations

Power supply

Versions

- Battery unit BU 191: special long-life high-power lithium-thionyl chloride battery unit
- Wide range power unit
- DC power unit, e.g. solar-powered

Power supply

- Wide range power unit: 24 V to 230 V AC/DC \pm 10 %, 50/60 Hz
- DC power unit: 8 to 50 V DC

In the event of an external power supply failure, wireless communication is maintained for at least one hour thanks to an internal power supply system.

Current consumption

- Wide range power unit: <350 mA, 1 A slow-blow back-up fuse must be installed by the customer onsite
- DC power unit: < 250 mA, 1 A slow-blow back-up fuse must be installed by the customer onsite

Power consumption

- Wide range power unit: max. active power 7 W / max. reactive power 12 VA with alternating voltage
- DC power unit: < 2.2 W

Battery capacity

- 19 Ah nominal capacity at 20 °C
- 7.2 V DC
- Lithium metal content: 10 g

Battery life Up to 10 years, depending on update rate of process variables, field device type and environmental conditions

Cable Field device connection

- Mounted directly on field devices: cable supplied (0.25 mm²)
- Remote mounting: standard installation cable (0.25 mm²)

Wide range power unit or DC power unit (M12 socket): 0.75 mm²

Performance characteristics

Reference operating conditions According to IEC 61298 Part 2

Maximum measured error 4 to 20 mA circuit: 0.125 % of measuring range

Influence of ambient temperature 4 to 20 mA circuit: 5 μ A/10 K

Operating conditions

Installation conditions

Installation	<ul style="list-style-type: none"> ▪ Directly on field device ▪ Remotely on a wall or pipe using optional mounting bracket
Installation instructions (recommendations)	<ul style="list-style-type: none"> ▪ Consider the range. See Seite 4, Range. ▪ Avoid mounting too near walls, pipes and heavy-duty electrical equipment. ▪ Mount in line of sight with a neighboring adapter and Fieldgate. ▪ Consider the development of the Fresnel zone. ▪ Align antenna so that it is completely vertical.
Protection against lightning	<ul style="list-style-type: none"> ▪ Do not mount the WirelessHART Adapter at the highest point in the plant. ▪ WirelessHART Adapter with metal housing: connect protective ground to protective ground connection of the housing. Protective ground in 2.5 mm².

Environment

Climate class	EN 60721-3-4: 4K4H, suitable for stationary use at unprotected outdoor locations
Ambient temperature range	<ul style="list-style-type: none"> ▪ -40 to +80 °C (-40 to +176 °F) ▪ Ex versions -40 to +60 °C (-40 to +146 °F) for temperature class T3 ▪ Ex versions -40 to +50 °C (-40 to +122 °F) for temperature class T4 ▪ The battery pack capacity decreases significantly at temperatures below -30 °C (-22 °F).
Storage temperature	<ul style="list-style-type: none"> ▪ WirelessHART Adapter without battery unit: -40 to +85 °C (-40 to +185 °F) ▪ WirelessHART Adapter with disconnected battery unit: -40 to +25 °C (-40 to +77 °F) ▪ Battery unit BU 191: -40 to +25 °C (-40 to +77 °F)
Vibration resistance	EN 60068-2-64: 20 Hz ≤ f ≤ 2000 Hz: 0.01 g ² /Hz
Shock resistance	EN 60068-2-27: 15 g, 11 ms
Electromagnetic compatibility	<p>All modules are suitable for industrial use and meet the requirements of EU Directive 2014/30/EU "Electromagnetic compatibility":</p> <ul style="list-style-type: none"> ▪ Emission: <ul style="list-style-type: none"> ▪ With wide range power unit: EN 61326-1: 2013, Class A ▪ With DC power unit or battery unit: EN 61326-1: 2013, Class B ▪ Interference immunity: <ul style="list-style-type: none"> ▪ EN 61326-1: 2013 Tab. 2 (industry) ▪ Namur recommendation EMC (NE21)

Temperature restrictions

The temperature restrictions listed are based on the assumption that more than 30% battery capacity is remaining.

**Ex version,
4 to 20 mA
supply mode**

The application range is limited in the event of high measuring currents close to 22 mA.

		Current strength in mA	
		4	22
Terminal voltage of field device in V	8	-40°C	-30°C
	10	-40°C	-30°C
	12	-40°C	-30°C
	14	-40°C	-25°C
	16	-40°C	-25°C
	18	-40°C	
	20	-40°C	
	22	-40°C	

**Ex version with fixed current
of 4 mA (multidrop mode)**

		Start-up current in mA See Operating Instructions, "Field device power supply" section.										
		4	6	8	10	12	14	16	18	20	22	
Terminal voltage of field device in V	8	-40°C	-40°C	-40°C	-40°C	-40°C	-40°C	-40°C	-40°C	-35°C	-25°C	-15°C
	10	-40°C	-40°C	-40°C	-40°C	-40°C	-40°C	-40°C	-40°C	-30°C	-15°C	-10°C
	12	-40°C	-40°C	-40°C	-40°C	-40°C	-40°C	-40°C	-35°C	-20°C		
	14	-40°C	-40°C	-40°C	-40°C	-40°C	-35°C	-25°C	-10°C			
	16	-40°C	-40°C	-40°C	-40°C	-40°C	-25°C					
	18	-40°C	-40°C	-40°C	-30°C	-5°C						
	20	-40°C	-35°C									
	22											

**Non-Ex version,
4 to 20 mA
supply mode**

The application range is limited in the event of high measuring currents close to 22 mA.

		Current strength in mA	
		4	22
Terminal voltage of field device in V	8	-40°C	-30°C
	10	-40°C	-30°C
	12	-40°C	-30°C
	14	-40°C	-25°C
	16	-40°C	-25°C
	18	-40°C	
	20	-40°C	
	22	-40°C	

Non-Ex version with fixed
current of 4 mA
(multidrop mode)

		Start-up current in mA									
		See Operating Instructions, "Field device power supply" section.									
		4	6	8	10	12	14	16	18	20	22
Terminal voltage of field device in V	8	-40°C	-40°C	-40°C	-40°C	-40°C	-40°C	-40°C	-40°C	-40°C	-40°C
	10	-40°C	-40°C	-40°C	-40°C	-40°C	-40°C	-40°C	-40°C	-40°C	-35°C
	12	-40°C	-40°C	-40°C	-40°C	-40°C	-40°C	-40°C	-40°C	-40°C	-35°C
	14	-40°C	-40°C	-40°C	-40°C	-40°C	-40°C	-40°C	-40°C	-35°C	-35°C
	16	-40°C	-40°C	-40°C	-40°C	-40°C	-40°C	-40°C	-40°C	-35°C	-20°C
	18	-40°C	-40°C	-40°C	-40°C	-40°C	-40°C	-40°C	-40°C	-35°C	
	20	-40°C	-40°C	-40°C	-40°C	-40°C	-40°C	-35°C			
	22	-40°C	-40°C	-40°C							

Mechanical construction

Design/dimensions

Dimensions in mm
25.4 mm = 1 inch

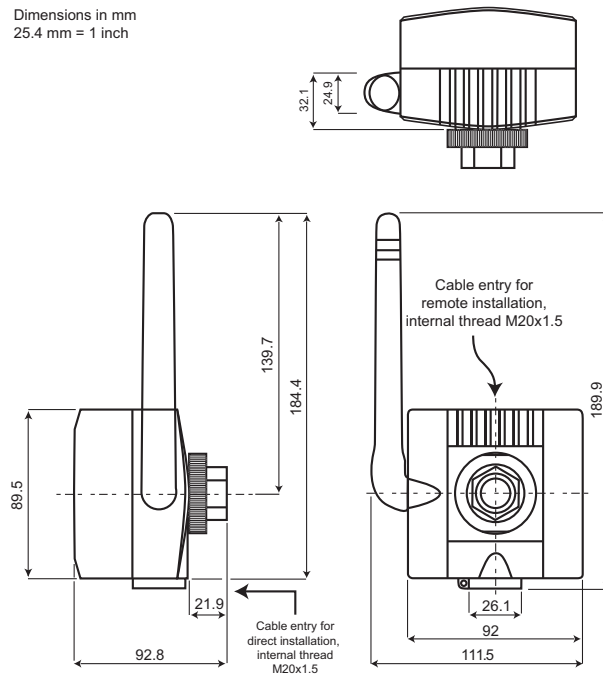

Weight

- Polyester housing with power supply unit: 0.785 kg
- Aluminum housing with power supply unit: 0.9 kg
- AISI 316L housing with power supply unit: 1.9 kg

Materials

- Housing: polyester or aluminum or AISI 316L, see ordering information
- Color of polyester and aluminum: light-gray, RAL 7035 with blue logo

Degree of protection

- Polyester housing F32: IP65/IP66; NEMA Type 4
- Aluminum housing F33: IP67, NEMA Type 4X
- AISI 316L housing F39: IP66/IP67, NEMA Type 4X

Connection adapters

M20x1.5 to M20x1.5; M20x1.5 to G 1/2; M20x1.5 to NPT 1/2; M20x1.5 to NPT 3/4
See ordering information

Antenna

Omnidirectional dipole antenna

Operation

Configuration	<ul style="list-style-type: none">▪ Local configuration with FieldCare or DeviceCare via modem and DTM for SWA70▪ Local operation with FieldXpert also in the hazardous area▪ Remote configuration with FieldCare via WirelessHART Fieldgate SWG70 and DTM for SWA70 and SWG70▪ Remote configuration with a software and a gateway based on the device description (DTM or DD)
Display and operating elements	Display and operating elements in WirelessHART Adapter: <ul style="list-style-type: none">▪ Push buttons for selecting various functions▪ LEDs for indicating communication status, battery status, voltage level and error messages
Device address	Can be configured between 0 to 63 via DD or DTM, default address 15

Ordering information

Product structure	Detailed information about the product structure is available: <ul style="list-style-type: none">▪ In the Product Configurator on the Endress+Hauser website: www.endress.com → Enter "SWA70" as the search string → click the "WirelessHART Adapter SWA70" link → In the window on the right under "Device support", click the link "Configure your selected product"▪ From your Endress+Hauser Sales Center: www.addresses.endress.com
--------------------------	---

Documentation

WirelessHART Adapter SWA70	<ul style="list-style-type: none"><input type="checkbox"/> WirelessHART Adapter SWA70 Operating Instructions BA00061S<input type="checkbox"/> WirelessHART Adapter SWA70 Safety Instructions ATEX, IECEx XA01366F<input type="checkbox"/> WirelessHART Adapter SWA70 Safety Instructions CSA XA00538F	<ul style="list-style-type: none"><input type="checkbox"/> WirelessHART solutions for real-world applications Competence brochure CP00013S<input type="checkbox"/> WirelessHART Fieldgate SWG70 Operating Instructions BA00064S<input type="checkbox"/> WirelessHART-Adapter SWA70 Safety Instructions EAC Ex XA01505F-A
-----------------------------------	---	--

Certificates and approvals

CE mark	The WirelessHART Adapter SWA70 meets the legal requirements of the relevant EU Directives. Endress+Hauser confirms successful testing of the WirelessHART Adapter SWA70 by affixing to it the CE mark.
Ex approval	See "Documentation" section.

Radio approvals

Europe This device meets the requirements of the RED "Radio Equipment Directive" 2014/53/EU.
This device meets the requirements of the RTTE Directive 1999/5/EU.

USA and Canada

FCC ID: 2A1KP-SWA70A
IC: 21533-SWA70A

This device has been tested and found to comply with the limits for a Class A digital device, pursuant to Part 15 of the FCC Rules. These limits are designed to provide reasonable protection against harmful interference when the device is operated in a commercial environment. This device generates, uses, and can radiate radio frequency energy and, if not installed and used in accordance with the instruction manual, may cause harmful interference to radio communications. Operation of this device in a residential area is likely to cause harmful interference in which case the user will be required to correct the interference at his own expense.

Changes or modifications made to this device not expressly approved by Endress+Hauser may void the FCC authorization to operate this device. This device must be installed to ensure a minimum antenna separation distance of 20 cm from all persons.

This device complies with Part 15 of the FCC Rules and with Industry Canada license-exempt RSS standard(s).

Operation is subject to the following two conditions:

- this device may not cause harmful interference, and
- this device must accept any interference received, including interference that may cause undesired operation.

Le présent appareil est conforme aux CNR d'Industrie Canada applicables aux appareils radio exempts de licence.

L'exploitation est autorisée aux deux conditions suivantes:

- l'appareil ne doit pas produire de brouillage, et
- l'utilisateur de l'appareil doit accepter tout brouillage radioélectrique subi, même si le brouillage est susceptible d'en compromettre le fonctionnement.

Other approvals

Other national approvals are available on request

Country	Approval/Guideline
Bulgaria	General authorization required for the use outdoors and in public.
Italy	General authorization necessary for the use outside of private terrain.
Norway	The operation can be restricted within a radius of 20 km from the center of Ny-Alesund.
Romania	In case of operation as secondary device; a special license is required.
Latvia	The outdoor use of the transmission frequency band of 2,4 GHz requires a national approval.

www.addresses.endress.com
