

Technical Information

Source container FQG61, FQG62

Radiometric level measurement

Technical Information and Operating Instructions



Source container with source insert for manual or pneumatic switch-ON/switch-OFF

Application

The FQG61 and FQG62 source containers are designed to hold the radioactive source during radiometric point level measurement, continuous level measurement and density measurement. The radiation is emitted almost unattenuated in one direction only, and is damped in all other directions. FQG61 and FQG62 differ from each other in terms of size and screening effect.

Your benefits

- Lightweight device provides best possible screening thanks to almost spherical design
- Safe and easy source replacement
- Highest safety classification for the source supplied (DIN 25426/ISO 2919, typical classification C66646)
- Compact device that is easy to mount
- Various angles of emission for optimum adaptation to the application
- Manual or pneumatic switch-ON/switch-OFF
- Padlock, cylinder lock or locking bolt for fixing the switch position
- Switch state easily identified
- Fire-resistant version +821 °C (+1510 °F) / 30 minutes

Table of contents

Product identification	3	Commissioning	40
About this document	4	Reading the switch state	40
Symbols used	4	Technical data of the pneumatic actuator	41
Documentation	4	Operation	42
Safety instructions	8	FQG61/FQG62; order code 020, option A	42
Designated use	8	FQG61/FQG62; order code 020, option B	43
Basic instructions for use and storage	8	FQG61/FQG62; order code 020, option C	45
Hazardous areas	8	FQG61/FQG62; order code 020, option D	46
General instructions on radiation protection	9	Maintenance and inspection	48
Legal regulations for radiation protection	9	Cleaning	48
Supplementary safety instructions	10	Maintenance and inspection	48
Function and system design	11	Routine tests of the shutter mechanism	48
Function	11	Routine leak testing	49
Attenuation factor and half-value layers	11	What to do in an emergency	51
Maximum activity of the radiation source	11	Emergency action	51
Dose rate diagrams	11	Notifying the competent authority	51
Mechanical construction	14	Procedures after termination of the application	52
Version	14	Internal measures	52
Design, dimensions	14	Return	52
Radiation emission channel	18	Ordering information	54
Weight	18	Ordering Information	54
Materials	19	Scope of delivery	54
Safety equipment	24	Delivery	54
Pneumatic drive	24	Accessories	55
Environment	25	Clamping device FHG61	55
Ambient temperature range	25	Measurement section FHG62	56
Ambient pressure	25		
Vibration resistance	25		
Fire	25		
Degree of protection	25		
Identification	26		
Nameplates	26		
RFID TAG	30		
Installation	32		
Incoming acceptance	32		
Transportation	32		
Mounting instructions	33		
Orientation for level measurement	34		
Orientation for point level detection	35		
Orientation for density measurement	36		
Orientation of the fireproof version	36		
Mounting device (supplied by customer)	37		
Toothed lock washers	37		
Tightening torque for mounting screws	38		
Post-installation check	38		
Connecting the pneumatic actuator	39		
Compressed air connection	39		
Connecting the proximity switches	39		

Product identification

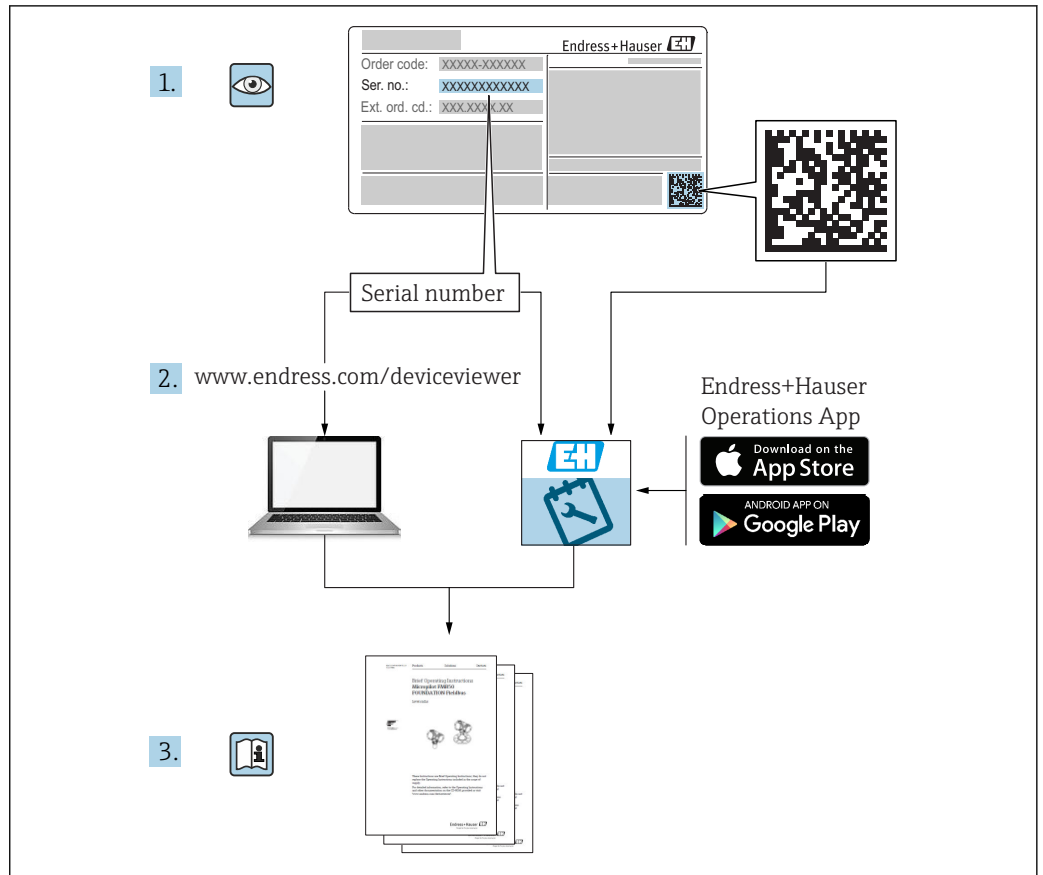

A0023555

About this document

Symbols used

Safety symbols

DANGER

This symbol alerts you to a dangerous situation. Failure to avoid this situation will result in serious or fatal injury.

WARNING

This symbol alerts you to a dangerous situation. Failure to avoid this situation can result in serious or fatal injury.









CAUTION

This symbol alerts you to a dangerous situation. Failure to avoid this situation can result in minor or medium injury.



NOTICE

This symbol contains information on procedures and other facts which do not result in personal injury.

Symbols for certain types of information

Symbol	Meaning
	Permitted Procedures, processes or actions that are permitted.
	Preferred Procedures, processes or actions that are preferred.
	Forbidden Procedures, processes or actions that are forbidden.
	Tip Indicates additional information.
	Reference to documentation
	Reference to page
	Reference to graphic
	Visual inspection

Symbols in graphics

Symbol	Meaning
1, 2, 3 ...	Item numbers
1., 2., 3. ...	Series of steps
A, B, C, ...	Views
A-A, B-B, C-C, ...	Sections
	Hazardous area Indicates a hazardous area.
	Safe area (non-hazardous area) Indicates the non-hazardous area.

Documentation



The following document types are available on the Internet at → www.de.endress.com

Returning source containers

Documentation	Comment
SD00309F/00	Returning source containers FQG60, FQG61, FQG62, FQG63, QG020, QG100

Returning source containers

Documentation	Comment
SD00311F/00	Special Documentation Type A packaging

Gamma radiation source FSG60/FSG61

Documentation	Comment
TI00439F/00	<ul style="list-style-type: none"> ▪ Technical Information for gamma radiation source FSG60/FSG61 ▪ Returning source containers ▪ Type A packaging

Source container FQG60, FQG61, FQG62, FQG63, FQG66

Documentation	Comment
SD00297F/00	Instructions for loading and changing the source. Label set

Clamping device FHG61

Documentation	Comment
SD01221F/00	Clamping device FHG61 For rectangular and diagonally irradiated pipes with a diameter 50 to 420 mm (1.97 to 16.5 in)

Measurement section FHG62

Documentation	Comment
SD00540F/00	Measurement section FHG62 for density measurements

Gamma modulator FHG65 Synchronizer FHG66

Documentation	Comment
TI00423F/00	Technical Information for gamma modulator FHG65 and synchronizer FHG66
BA00373F/00	Operating Instructions for gamma modulator FHG65 and synchronizer FHG66

Source container FQG66

Documentation	Comment
TI01171F/00	Technical Information for source container FQG66
BA01327F/00	Operating Instructions for source container FQG66

Gammapilot M FMG60

Documentation	Comment
TI00363F/00	Technical Information for Gammapilot M FMG60
BA00236F/00	Operating Instructions for Gammapilot M FMG60 (HART)
BA00329F/00	Operating Instructions for Gammapilot M FMG60 (PROFIBUS PA)
BA00330F/00	Operating Instructions for Gammapilot M FMG60 (FOUNDATION Fieldbus)

Gammapilot FTG20

Documentation	Comment
TI01023F/00	Technical Information for Gammapilot FTG20
BA01035F/00	Operating Instructions for Gammapilot FTG20

RFID TAG

Documentation	Comment
SD01502F/00 document, which is supplied separately	Special Documentation RFID TAG
ZE01020F/00	RFID TAG Certificate/Declaration of Conformity

Supplementary instruction manuals*Supplementary instruction manuals*

Documentation	Comment
SD00292F/00	Supplementary instruction manual for Canada
SD00293F/00	Supplementary instruction manual for the United States
XA01633F/00	Safety Instructions ATEX II 2 G

Certificate of suitability

**Eignungsbescheinigung
Manufacturer Declaration**



Company **Endress+Hauser SE+Co. KG, Hauptstraße 1, 79689 Maulburg**

erklärt als Hersteller, dass das folgende Produkt
declares as manufacturer, that the following product

Product **Strahlenschutzbehälter/ Radiation Source Container**
Typ FQG60, FQG61, FQG62, FQG63, FQG66

den Anforderungen über die internationale Beförderung gefährlicher Güter ADR/RID (2019) und IATA/DGR (2019) an ein Typ A Versandstück entspricht. Die Strahlenschutzbehälter sind für den Transport von umschlossenen radioaktiven Stoffen und von umschlossenen radioaktiven Stoffen in besonderer Form vorgesehen.

Die Eignung als Typ A Versandstück wurde durch eine Baumusterprüfung nach den Anforderungen von IAEA-TS-R-1 (2005) Kapitel 6 nachgewiesen und in den internen Dokumenten 961000072, 960009590, 961000169, 961000170 niedergelegt.

Die Qualitätssicherung während der Entwicklung, der Herstellung und der Prüfung der Strahlenschutzbehälter erfolgt gemäß BAM-GGR016 Rev. 0 vom 10. Nov. 2014. Der Ablauf ist im Qualitätssicherungsprogramm für Typ A Versandstücke (Dokument: GL_0372) beschrieben

confirms the requirements on international transportation of hazardous materials ADR/RID (2019) and IATA/DGR (2019) for Type A packaging and is suitable for the transportation of sealed radioactive material and sealed special form radioactive material.

The qualification as type A packaging is tested by an type approval according to IAEA-TS-R-1 (2005) section 6 and documented by the internal reports 961000072, 960009590, 961000169, 961000170.

The quality management during development, manufacturing and testing of the source containers is following the requirements of TRV006 and BAM-GGR016 Rev. 0 from 2014.Nov.10. It is described in the quality program for Type A packaging (document: GL_0372).

Maulburg, 30-August-2019
Endress+Hauser SE+Co. KG

i.A. Dr. Karl Barton
Gefahrgutbeauftragter
Security adviser for the transport of dangerous
goods

Safety instructions

Designated use

The FQG61 and FQG62 source containers described in this document contain the radioactive source, which is used for radiometric measurement of level, interface and density. They screen the radiation from the surrounding environment and allow it to be emitted almost unattenuated in the direction of measurement only. In order to guarantee the screening effect and rule out damage to the radiation source, it is essential to comply strictly with all the instructions provided in this Technical Information document for mounting and operating the unit, as well as all legal regulations surrounding radiation protection. Endress+Hauser does not accept any responsibility for damage caused by incorrect use.

Basic instructions for use and storage

- Observe the applicable regulations and national/international standards.
- Comply with radiation protection regulations when using, storing and working with the radiometric measuring system.
- Heed warning signs and observe safety zones.
- Install and operate the device according to the instructions in this document and as specified by the regulatory authority.
- Never operate or store the device outside the specified parameters.
- When operating and storing the device, protect it against extreme influences (i.e. chemical products, weather, mechanical impacts, vibrations etc.).
- Always secure the OFF position of the source insert using the padlock
- Before switching on the radiation, make sure that no-one is in the radiation zone (or inside the product vessel). The radiation may only be switched ON by properly instructed staff.
- Do not operate damaged or corroded devices. Notify the competent radiation safety officer as soon as damage or corrosion occurs, and follow his/her instructions.
- Conduct the required leak testing procedure according to the applicable regulations and instructions

WARNING

Vibrations and mechanical impacts

- ▶ If the device is exposed to strong vibrations or mechanical impacts, the safety pin can become abraded. This may cause the source insert to fall out of the container.
- ▶ Therefore, the source holder must be checked at regular intervals to ensure that it is secure and stable

CAUTION

Condition of the system

- ▶ If there are any doubts about the proper condition of the system, check the area around the device for leakage radiation and notify the competent radiation safety officer.

Hazardous areas

General instructions

CAUTION

Suitability

- ▶ The suitability of the radiometric measurement method and of the device for applications in hazardous areas must be checked by the plant operator according to the national rules and regulations that apply.

The following must be observed:

- Avoid electrostatic charge at the device. Do not rub dry.
- The device must be integrated in the potential equalization system of the plant. In order to ensure electrical contact between the radiation source container and the mounting support, the supplied toothed lock washers must be used. →  37

If an RFID tag is used, comply with the instructions in the



SD01502F/00 document, which is supplied separately

Additional instructions for pneumatically operated radiation source containers

CAUTION

Hazardous areas

- ▶ For applications in hazardous areas categorized as ATEX II 2 G, the associated Safety Instructions (XA) must be observed.
- ▶ The pneumatic drive may not be operated in locations where the ambient conditions may lead to corrosion in or at the pneumatic drive.

General instructions on radiation protection

When working with radioactive sources, avoid any unnecessary exposure to radiation. All unavoidable radiation exposure must be kept to a minimum. Three basic concepts apply to achieve this:

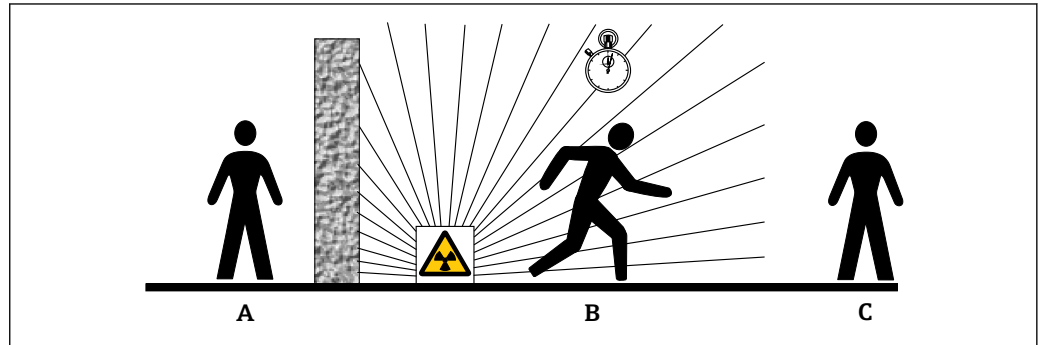

A0016373

- A *Screening*
- B *Time*
- C *Distance*

Screening

Ensure the best possible screening between the radiation source and yourself and all other persons. Source containers (e.g. FQG60, FQG61/FQG62, FQG63, FQG66) and all high-density materials (lead, iron, concrete etc.) can be used for effective screening purposes.

Time

The time spent in the exposed area should be kept to a minimum.

Distance

Keep as far away from the radiation source as possible. The local radiation dose rate decreases in proportion to the square of the distance from the radiation source.

Legal regulations for radiation protection

The handling of radioactive emitters is legally controlled. The radiation protection regulations of the country in which the plant is operated are of overriding importance and must be strictly observed. In the Federal Republic of Germany, the current version of the Radiation Protection Ordinance applies. The following points derived from this Ordinance are particularly important for radiometric measurement:

Handling permit

A handling permit is required for operating a plant which uses gamma radiation. Permit applications are made to the local state government or the authority responsible (State Offices for Environmental Protection, Trade Inspection Offices, etc.). The Endress+Hauser sales organization will be happy to help you obtain the handling permit.

Radiation safety officer

The plant operator must appoint a radiation safety officer (RSO) who has the necessary specialist knowledge and who is responsible for observing the Radiation Protection Ordinance and all radiation protection procedures. Endress+Hauser offers training courses in which individuals can acquire the necessary specialist knowledge.

Control zone

Only persons who are exposed to radiation during the course of their job and are subject to official personal dose monitoring procedures may work in control zones (i.e. areas where the local dose rate exceeds a specific value). The limit values for the control zone are specified in the current Radiation Protection Ordinance applicable for your area. The Endress+Hauser sales organization will be pleased to provide further information on radiation protection and regulations in other countries.

Supplementary safety instructions

Observe the associated safety instructions contained in the following documents:



SD00292F/00 (for Canada)



SD00293F/00 (for the United States)



This document, together with the nameplates, constitutes the documentation for highly radioactive radiation sources as stipulated in Section 94 (3) of the Radiation Protection Ordinance in Germany.

⚠ CAUTION

This device contains more than 0.1% lead with CAS No. 7439-92-1.

- ▶ The lead is not accessible in vessels that are free from damage. If the vessel is damaged, national regulations surrounding the handling of lead must be observed.

Function and system design

Function

Function of the radiation source container

In the FQG61/FQG62 source container, the radioactive source is surrounded by a steel casing filled with lead which screens off gamma radiation. The radiation can be emitted, almost unattenuated, in one direction only through a channel (focused narrow beam path). This radiation is used for radiometric measurement.

Switching the radiation ON and OFF

- By turning the insert 180°, the radiation source is positioned in the radiation emission channel (radiation is switched on) and removed from the channel (radiation is switched off).
- The current switch position (ON or OFF) is clearly visible from the outside.
- The OFF position can be secured by a cylinder lock or padlock (depending on the version; see product structure: order code 020, "Version").
- The ON position can be secured by a cylinder lock, a padlock or a locking bolt (depending on the version; see product structure: order code 020, "Version").

Remote control/remote indication of the switch state

Device versions with a pneumatic drive are available, which enable the radiation to be switched on and off remotely (product structure: order code 020, "Version K, L, M, N"). These versions have proximity switches for remote indication of the switch state (ON or OFF).

Fire-resistant version

A fire-resistant version of the radiation source containers is available (product structure: order code 670 "Additional function"). This version has a compensation compartment, which is welded onto the housing. In the event of a fire, the liquefied lead is collected in the compensation compartment, thus ensuring the enhanced fire-resistance of the source container.

Attenuation factor and half-value layers

	FQG61 ⁶⁰ Co	FQG61 ¹³⁷ Cs	FQG62 ⁶⁰ Co	FQG62 ¹³⁷ Cs
Attenuation factor F_s	37	294	181	3100
Number of half-value layers	5.2	8.2	7.5	11.6

 The table contains typical values, which do not take into account production-related variations in the source activity and tolerances of the measuring devices.

Maximum activity of the radiation source

Source container	⁶⁰ Co	¹³⁷ Cs
FQG61	max. 0.74 GBq (20 mCi)	max. 18.5 GBq (500 mCi)
FQG62	max. 3.7 GBq (100 mCi)	max. 111.0 GBq (3000 mCi)

CAUTION

Maximum admissible activity

- ▶ The maximum admissible activity can be further restricted by country-specific approvals.

Dose rate diagrams

A dose rate diagram specifies the local dose rate at a specified distance from the surface of the radiation source container. Examples of dose rate diagrams for FQG61 and FQG62 are presented below. They apply for a distance of 1 m (3.3 ft) and for selected activities of a ⁶⁰Co or ¹³⁷Cs radiation source. All the dose rate diagrams indicated refer to the OFF switch position and to order code 020 "Version", option A "Cylinder lock fixation ON/OFF + cover". The maximum values apply outside the path of the beam. Dose rate diagrams for other distances and activities are available on request. The

dose rate diagram for the real loading and version can be ordered with order code 580 "Test, Certificate".

i For the allocation of the device version, see the Product Configurator on the Endress+Hauser website: www.endress.com → Select your country → Products → Select measuring technology, software or components → Select the product (picklists: measurement method, product family etc.) → Device support (right-hand column): Configure the selected product → The Product Configurator for the selected product opens

Dose rate diagrams for ^{60}Co

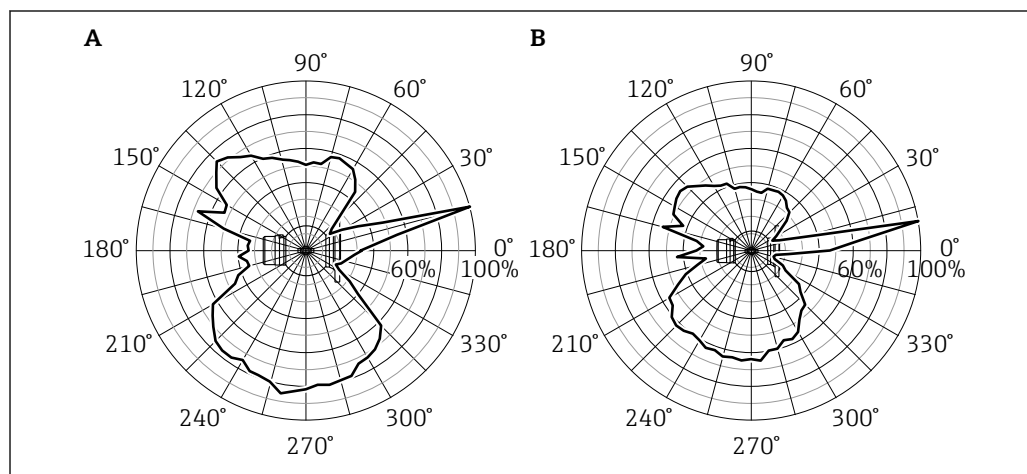

A0018270

A FQG61
B FQG62

Option in order code 100 "Prepared for source activity"	FQG61 Activity in MBq	FQG62 Activity in MBq	FQG61 Max. value (100%) in $\mu\text{Sv/h}$	FQG62 Max. value (100%) in $\mu\text{Sv/h}$
AA	3.7	3.7	0.04	0.01
AB	7.4	7.4	0.08	0.02
AC	18.5	18.5	0.21	0.05
AD	37	37	0.42	0.10
AE	74	74	0.85	0.20
AF	111	111	1.27	0.30
AG	185	185	2.12	0.50
AH	370	370	4.24	1.01
AK	740	740	8.49	2.02
AL	-	1110	-	3.03
AM	-	1850	-	5.04
AN	-	3700	-	10.09

Dose rate diagrams for ¹³⁷Cs

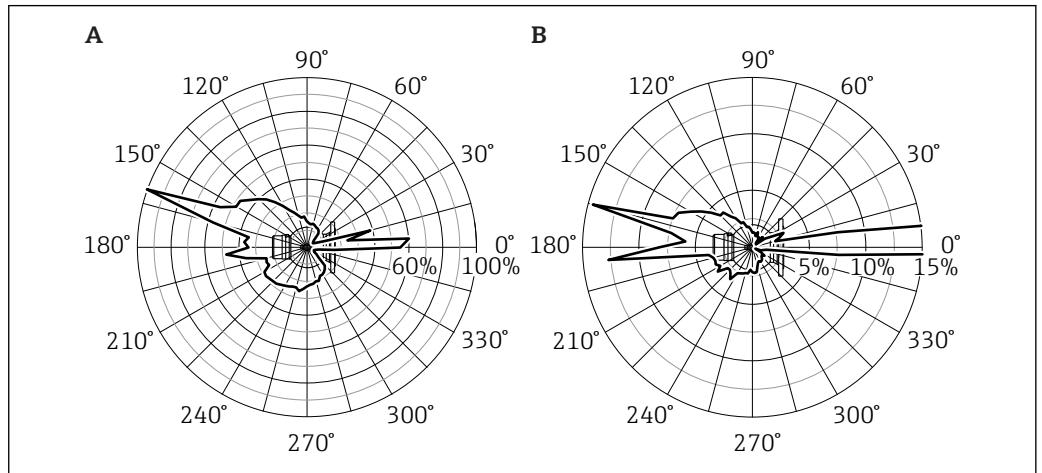

A0018384

A FQG61
B FQG62

Option in order code 100 "Prepared for source activity"	FQG61 Activity in MBq	FQG62 Activity in MBq	FQG61 Max. value (100%) in µSv/h	FQG62 Max. value (100%) in µSv/h
AA	3.7	3.7	< 0.01	< 0.01
AB	7.4	7.4	< 0.01	< 0.01
AC	18.5	18.5	0.01	< 0.01
AD	37	37	0.01	0.01
AE	74	74	0.02	0.01
AF	111	111	0.04	0.02
AG	185	185	0.06	0.03
AH	370	370	0.12	0.06
AK	740	740	0.24	0.12
AL	1110	1110	0.36	0.18
AM	1850	1850	0.60	0.30
AN	3700	3700	1.20	0.60
AP	7400	7400	2.39	1.19
AR	11100	11100	3.59	1.79
AT	18500	18500	5.98	2.98
AW	-	29600	-	4.77
BB	-	37000	-	5.96
BC	-	55500	-	8.94
BD	-	74000	-	11.91
BF	-	111000	-	17.87

Mechanical construction

Version	Order code 020 in the product structure	Properties
A		<ul style="list-style-type: none"> Source insert for manual switch-ON/switch-OFF Cylinder lock to secure the ON/OFF switch position Cover
B		<ul style="list-style-type: none"> Swivel bracket for manual switch-ON/switch-OFF Locking bolt to secure the ON switch position Padlock to secure the OFF switch position
C		<ul style="list-style-type: none"> Swivel bracket for manual switch-ON/switch-OFF Padlock to secure the ON/OFF switch position
D		<ul style="list-style-type: none"> Higher protection against dust and humidity Swivel bracket for manual switch-ON/switch-OFF Padlock to secure the ON/OFF switch position
K		<ul style="list-style-type: none"> Pneumatic switch-ON/switch-OFF
L		<ul style="list-style-type: none"> Padlock to secure the OFF switch position
M		<ul style="list-style-type: none"> Higher protection against dust and humidity
N		<ul style="list-style-type: none"> Pneumatic switch-ON/switch-OFF Padlock to secure the OFF switch position

Design, dimensions

FQG61/FQG62; order code 020, option A → 54

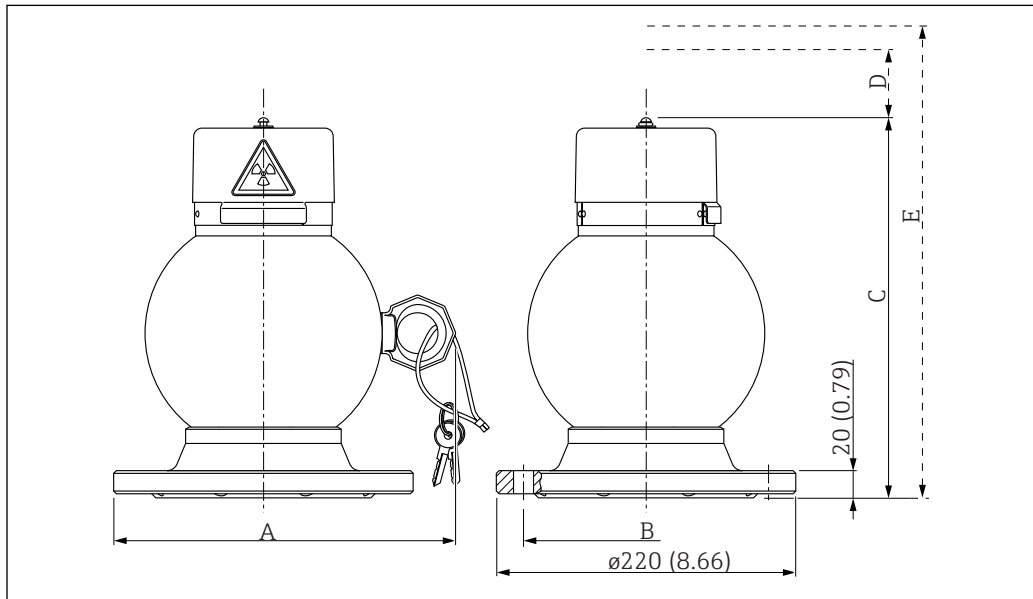

A0018385

1 Dimensions: mm (in)

Dimensions	Version	mm (in)	Comment
A	FQG61	251 (9.88)	
	FQG62	272 (10.7)	
B	FQG61	The mounting flange of FQG61 and FQG62 is compatible with: DN 100 PN16 (ø 180 mm (7.09 in)) and ANSI 4" 150 lbs (ø 190 mm (7.48 in))	
	FQG62		
C	FQG61	279 (11)	
	FQG62	360 (14.2)	
D	FQG61	75 (2.95)	Clearance for cover removal
	FQG62		

Dimensions	Version	mm (in)	Comment
E	FQG61	479 (18.9)	Clearance required to replace the radiation source
	FQG62	560 (22)	

FQG61/FQG62; order code 020, option B → 54

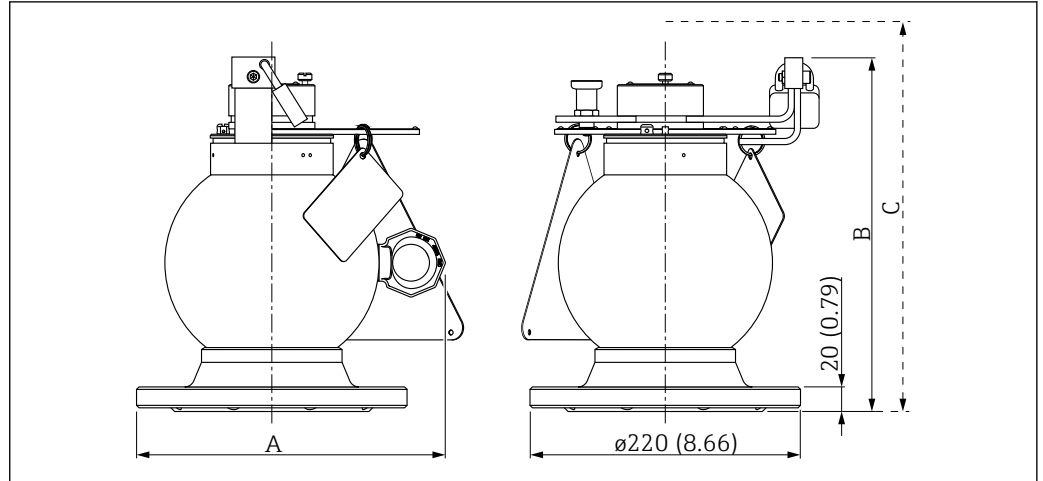

A0018386

2 Dimensions: mm (in)

Dimensions	Version	mm (in)	Comment
A	FQG61	251 (9.88)	
	FQG62	272 (10.7)	
B	FQG61	287 (11.3)	
	FQG62	368 (14.5)	
C	FQG61	450 (17.7)	Clearance required to replace the radiation source
	FQG62	580 (22.8)	

FQG61/FQG62; order code 020, option C → 54

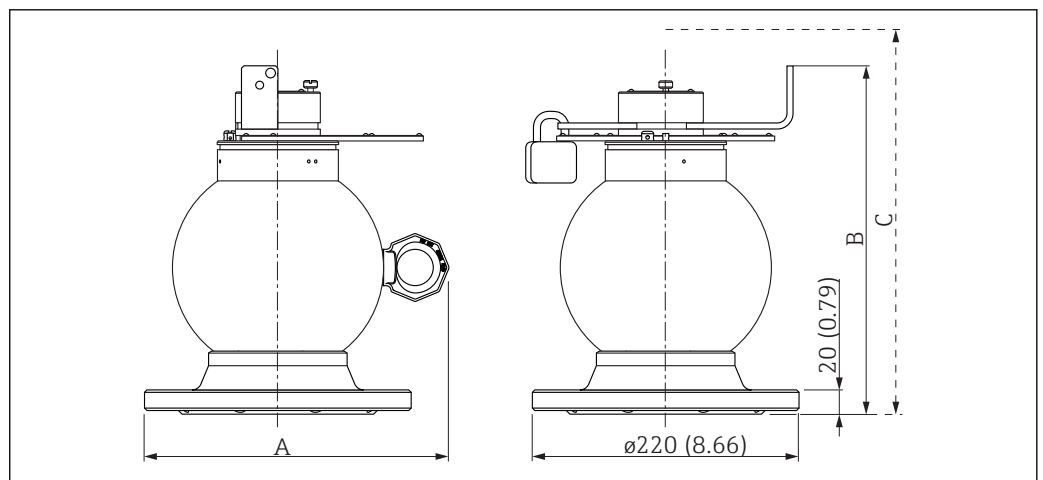

A0018387

3 Dimensions: mm (in)

Dimensions	Version	mm (in)	Comment
A	FQG61	251 (9.88)	
	FQG62	272 (10.7)	
B	FQG61	287 (11.3)	
	FQG62	368 (14.5)	
C	FQG61	450 (17.7)	Clearance required to replace the radiation source
	FQG62	570 (22.4)	

FQG61/FQG62; order code 020, option D → 54

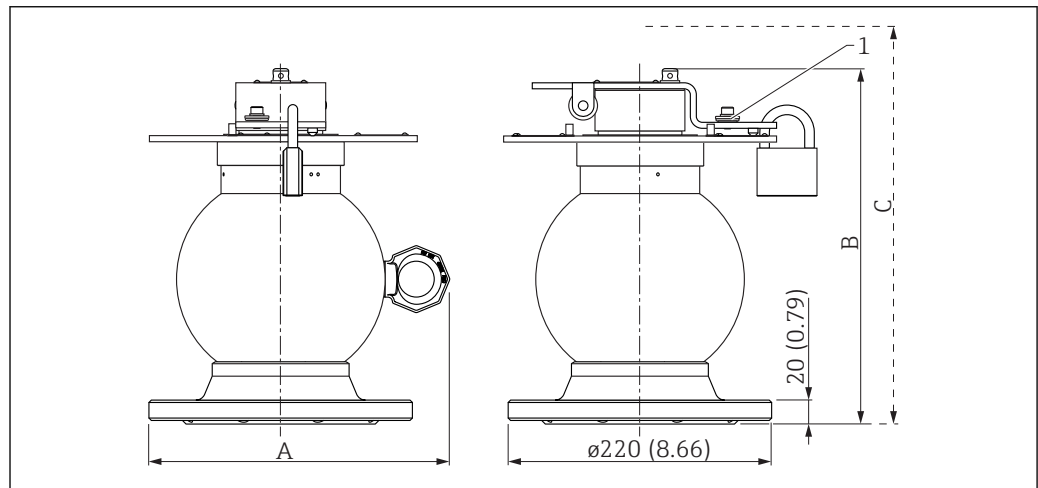

4 Dimensions: mm (in)

1 Reference O-ring

Dimensions	Version	mm (in)	Comment
A	FQG61	251 (9.88)	
	FQG62	272 (10.7)	
B	FQG61	297 (11.7)	
	FQG62	378 (14.9)	
C	FQG61	497 (19.6)	Clearance required to replace the radiation source
	FQG62	578 (22.8)	

FQG61/FQG62; order code 020, option K, L, M or N → 54

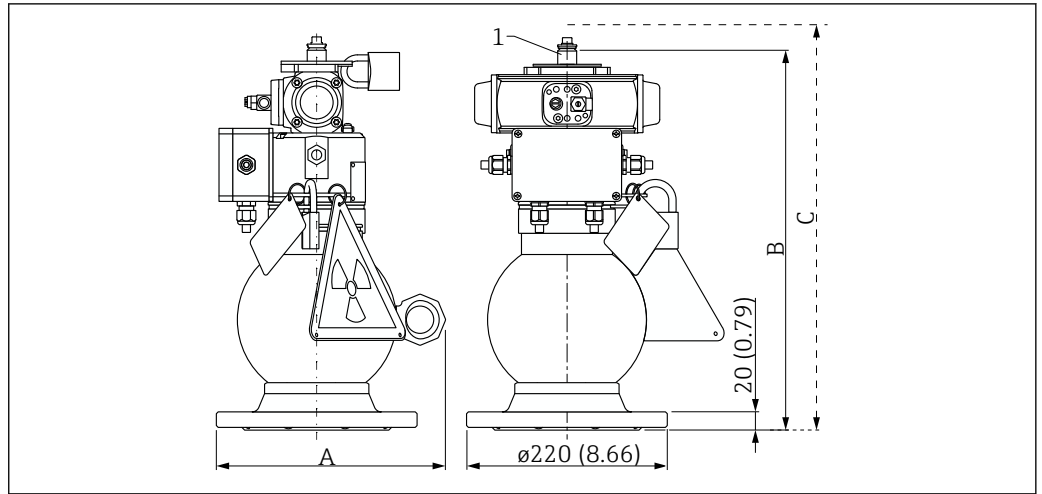

A0018389

5 Dimensions: mm (in)

1 Reference O-ring

Dimensions	Version	mm (in)	Comment
A	FQG61	251 (9.88)	
	FQG62	272 (10.7)	
B	FQG61	427(16.8)	
	FQG62	508 (20.0)	
C	FQG61	483 (19.0)	Clearance required to replace the radiation source
	FQG62	602 (23.7)	

"Fire-resistant" additional feature (FQG61/FQG62; order code 670, option WE) → 54

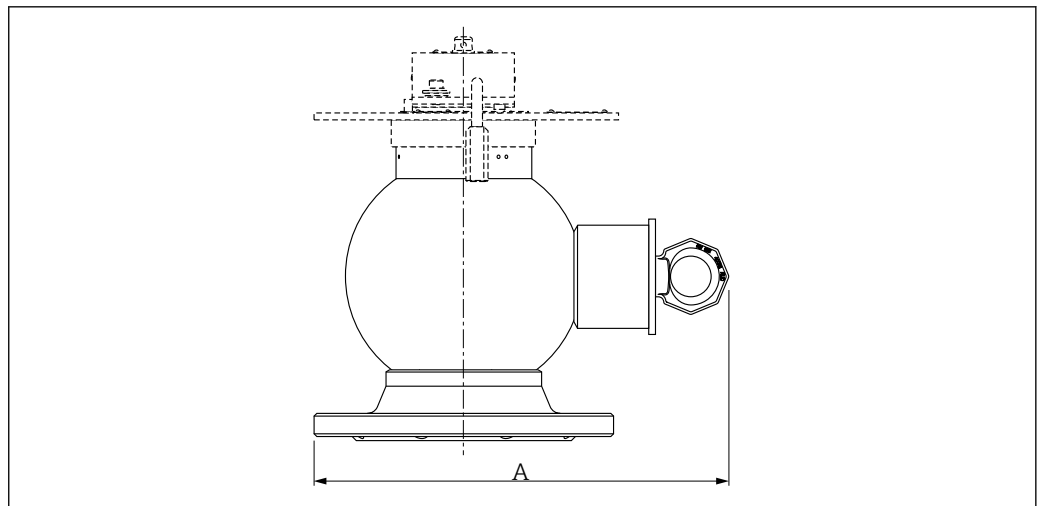

A0018390

6 Dimension A

Dimensions	Version	mm (in)	Comment
A	FQG61	305 (12)	
	FQG62	362 (14.3)	

Radiation emission channel

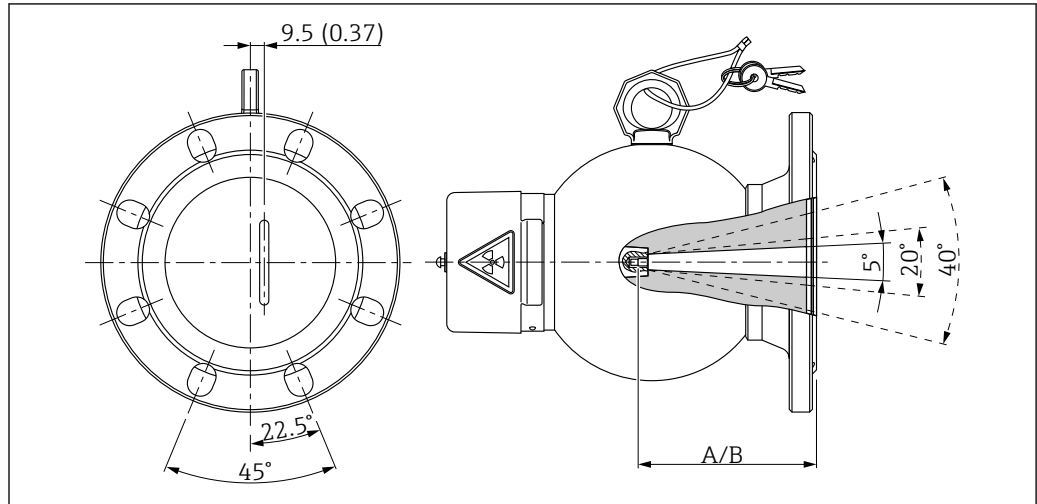

A0018391

7 Dimensions: mm (in)

- A FQG61: 123 mm (4.84 in)
- B FQG62: 166 mm (6.54 in)

Position	The emission channel is located at a distance of 9.5mm (0.37 in) from the center of the mounting flange. It has the same direction as the lifting eye of the radiation source container. The radiation emission channel is indicated by a mark on the covering plate of the mounting flange.
Angle of emission	According to feature 240 of the product structure: <ul style="list-style-type: none"> ▪ 5° ▪ 20° ▪ 40°
Width of emission	<ul style="list-style-type: none"> ▪ FQG61: 10 mm (0.39 in) ▪ FQG62: 12 mm (0.47 in)
Attenuation of the useful beam	Approx. 0.3 half-value layers ($F_S = 1.2$)

Weight

Source container	With manual switch-ON/switch-OFF	With pneumatic switch-ON/switch-OFF
FQG61	Approx. 42 kg (92.59 lb)	Approx. 46 kg (101.41 lb)
FQG62	Approx. 86 kg (189.60 lb)	Approx. 90 kg (198.42 lb)

Materials

FQG61/FQG62; order code 020, option A → 54

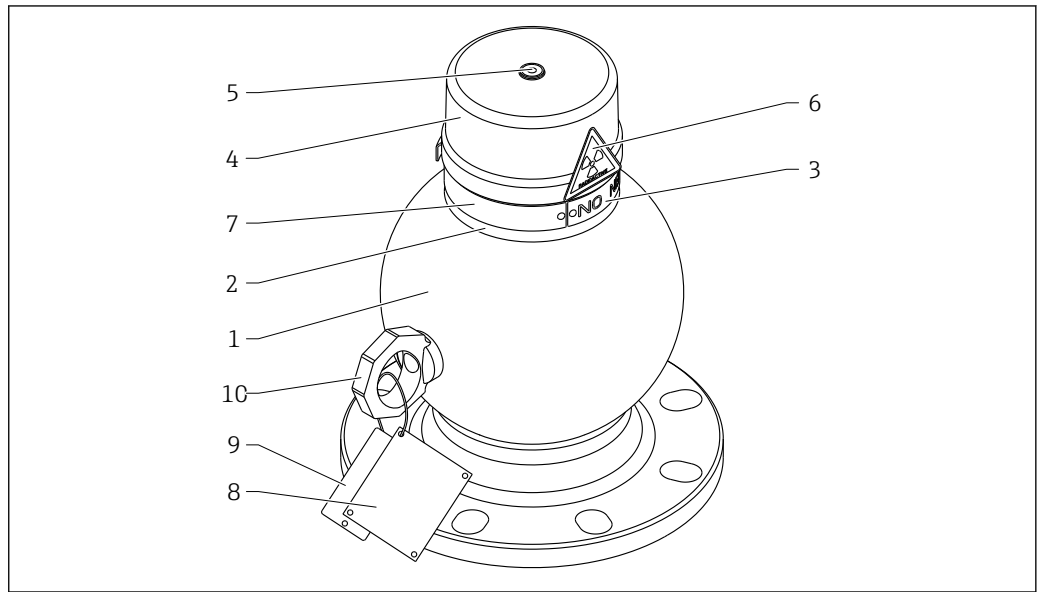

A0018393

8 List of materials

Item	Component part	Material
1	Housing	316Ti (1.4571); S235JR (1.0038)
	Flange	316L (1.4404)
2	Housing ring	316L (1.4404); 304 (1.4301)
3	Nameplate	316L (1.4404)
4	Cover	304 (1.4301)
	O-ring	FKM
5	Screw/groove pin	A2
6	Warning sign	Acrylate foil
7	Nameplate for radiation source	304 (1.4301)
8	Tag	304 (1.4301)
	Cable	316 (1.4401)
9	Tag	304 (1.4301)
	Cable	316 (1.4401)
10	Ring eyelet	C15; A4

Item	Component part	Varnish
1	Housing, flange	PUR 2K texture paint RAL1003
4	Cover	

FQG61/FQG62; order code 020, option B → 54

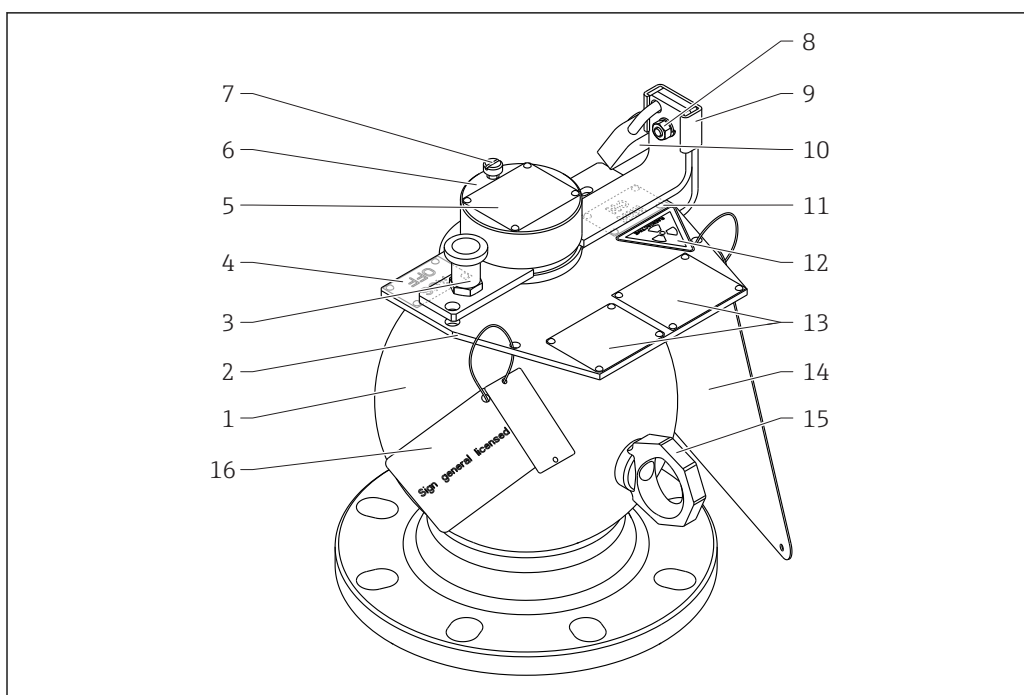

A0018394

Item	Component part	Material
1	Housing	316Ti (1.4571); S235JR (1.0038)
	Flange	316L (1.4404)
2	Indication plate	316L (1.4404)
3	Rotating pin	316L (1.4404)
4	"AUS/OFF" sign	304 (1.4301)
5	"Source" nameplate	304 (1.4301)
6	Rotary element	316L (1.4404)
7	Screw	A4
8	Screw	A4
	Nut	A4
9	Bracket	A4
10	Padlock: body	Brass
	Padlock: shackle	Hardened steel
11	"EIN/ON" sign	304 (1.4301)
12	"CAUTION!" warning sign	Acrylate foil
13	Additional national sign	304 (1.4301)
	"Container" nameplate	304 (1.4301)
14	"Caution radiation" sign	304 (1.4301)
15	Ring eyelet	C15; A4
16	Tag	304 (1.4301)
	Cable	316 (1.4401)

Item	Component part	Varnish
1	Housing, flange	PUR 2K texture paint RAL1003

FQG61/FQG62; order code 020, option C → 54

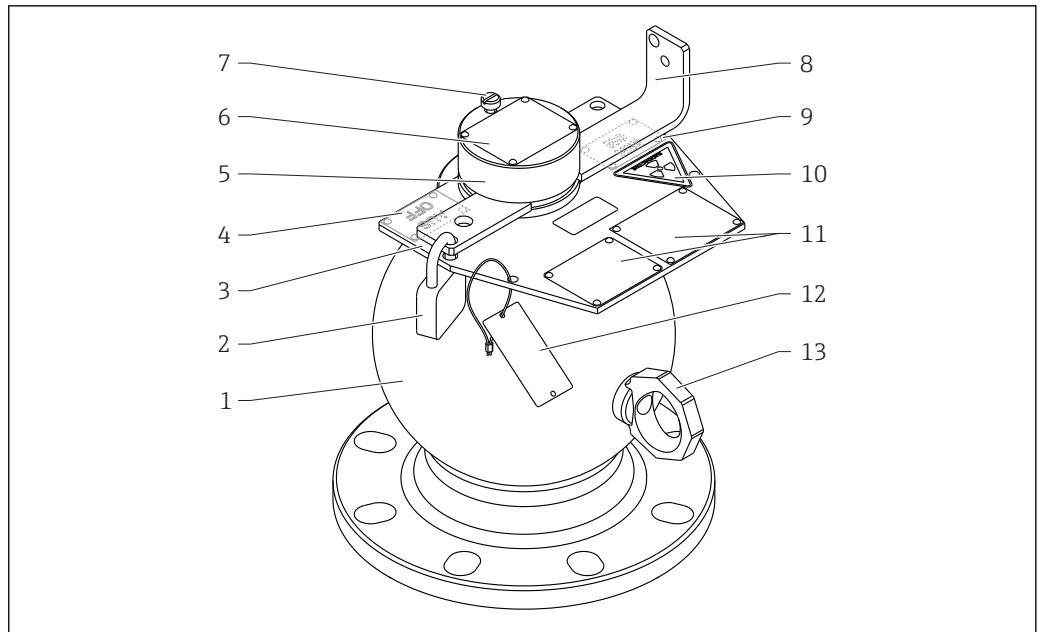

A0018395

Item	Component part	Material
1	Housing	316Ti (1.4571); S235JR (1.0038)
	Flange	316L (1.4404)
2	Padlock: body	Brass
	Padlock: shackle	Hardened steel
3	Indication plate	316L (1.4404)
4	"AUS/OFF" sign	304 (1.4301)
5	Rotary element	316L (1.4404)
6	"Source" nameplate	304 (1.4301)
7	Screw	A4
8	Swivel bracket	316L (1.4404)
9	"EIN/ON" sign	304 (1.4301)
10	"CAUTION!" warning sign	Acrylate foil
11	Additional national sign	304 (1.4301)
	"Container" nameplate	304 (1.4301)
12	Tag	304 (1.4301)
	Cable	316 (1.4401)
13	Ring eyelet	C15; A4

Item	Component part	Varnish
1	Housing, flange	PUR 2K texture paint RAL1003

FQG61/FQG62; order code 020, option D → 54

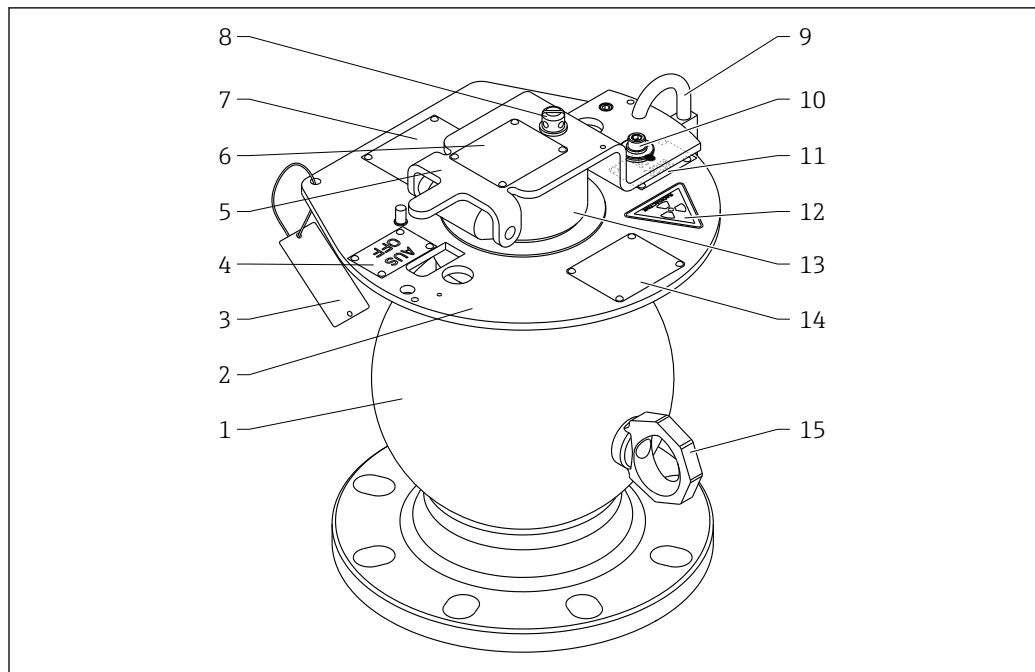

A0018396

Item	Component part	Material
1	Housing	316Ti (1.4571); S235JR (1.0038)
	Flange	316L (1.4404)
2	Indication plate	316L (1.4404)
3	Tag	304 (1.4301)
	Cable	316 (1.4401)
4	"AUS/OFF" sign	304 (1.4301)
5	Swivel bracket	316L (1.4404)
6	"Source" nameplate	304 (1.4301)
7	Additional national sign	304 (1.4301)
8	Mounting	A2
9	Padlock: body	Brass
	Padlock: shackle	Hardened steel
10	Screw	A4
	Spring ring	A2
	Protector cap	304 (1.4301)
	Reference O-ring	FKM
11	"EIN/ON" sign	304 (1.4301)
12	"CAUTION!" warning sign	Acrylate foil
13	Rotary element	316L (1.4404)
14	"Container" nameplate	304 (1.4301)
15	Ring eyelet	C15; A4

Item	Component part	Varnish
1	Housing, flange	PUR 2K texture paint RAL1003

FQG61/FQG62; order code 020, option K, L, M or N → 54

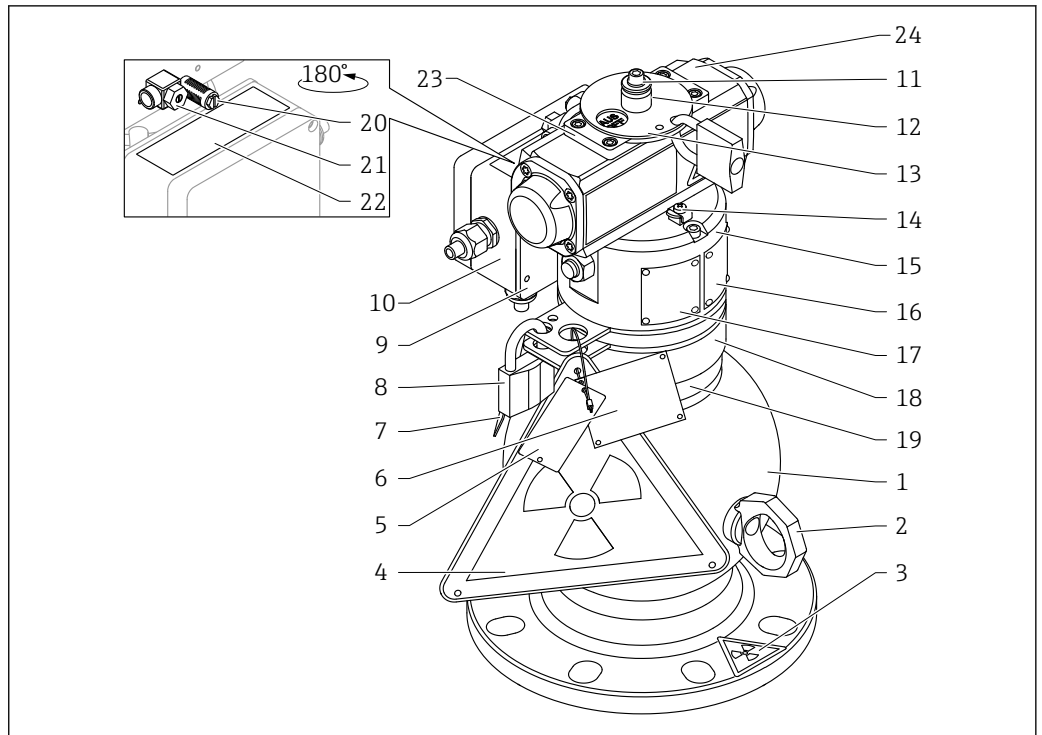

A0018397

Item	Component part	Material
1	Housing	316Ti (1.4571); S235JR (1.0038)
	Flange	316L (1.4404)
2	Ring eyelet	C15; A4
3	"CAUTION! Radioactive" warning sign	Acrylate foil
4	"Caution radiation" sign	304 (1.4301)
5, 6	Tag	304 (1.4301)
7	"Radioactive material" sign	304 (1.4301)
8	Padlock: body	Brass
	Padlock: shackle	Hardened steel
9	Securing plate	316L (1.4404)
10	Terminal housing	PC
11	Screw	A4
	Spring ring	A2
	Protector cap	304 (1.4301)
	Reference O-ring	FKM
12	Ferrule	316L (1.4404)
13	Disk	316L (1.4404)
14	Ground terminal	Screw: A4; spring washer: A4; clamp: 316L (1.4404); terminal block: 316L (1.4404)
15	Cover	316L (1.4404)
16	"Australia" nameplate	304 (1.4301)
17	"Container" nameplate	304 (1.4301)
18	Adapter disk	316L (1.4404)

Item	Component part	Material
19	"Source" nameplate	304 (1.4301)
20	Muffler G1/8	ABS
21	Check valve G1/8	MS
22	Terminal housing nameplate (non Ex/EX)	Laser foil
23	Indication plate	316L (1.4404)
24	Pneumatic drive	Cast aluminum

Item	Component part	Varnish
1	Housing, flange	PUR 2K texture paint RAL1003
16	"Australia" nameplate	

Safety equipment

A padlock, cylinder lock or locking bolt (depending on the device version) ensure:

- The "ON" or "OFF" switch position is secured
- Protection against theft

Pneumatic drive

The following applies for the version with pneumatic switch-ON/switch-OFF:

- Swivel range: 180 °
- Compressed air connection: G1/8
- Actuating pressure: 3.5 to 6 bar (51 to 87 psi)
- Reset by spring force
- Required compressed air quality: ISO 8573-1 Class 3; maximum particle size 40 µm, pressure dewpoint corresponding to a dewpoint of -20°C or a dewpoint of at least 10 K below ambient temperature

 The device corresponds to Article 4 (3) of EU Directive 2014/68/EU (Pressure Equipment Directive) and has been designed and manufactured in accordance with good engineering practice.

Environment

Ambient temperature range	Version	Ambient temperature range
	Manual switch-ON/switch-OFF	-40 to +200 °C (-40 to +392 °F)
	Pneumatic switch-ON/switch-OFF	-20 to +80 °C (-4 to 176 °F)



If an RFID tag is used, temperature range restrictions must be taken into consideration. See SD01502F/00

Ambient pressure Atmospheric pressure

Vibration resistance DIN EN 60068-2-64 test Fh; 10 to 2000 Hz; 1 g²/Hz

Fire

For all versions

5 minutes at 538 °C (1 000 °F) according to ANSI N 43.8

For the fire-resistant version (feature 670 "Additional function", option WE)

30 minutes at 821 °C (1 510 °F) according to ISO 7205

Degree of protection IPx6 and NEMA TYPE 4

Identification

Nameplates

FQG61/FQG62; order code 020, option A → 54

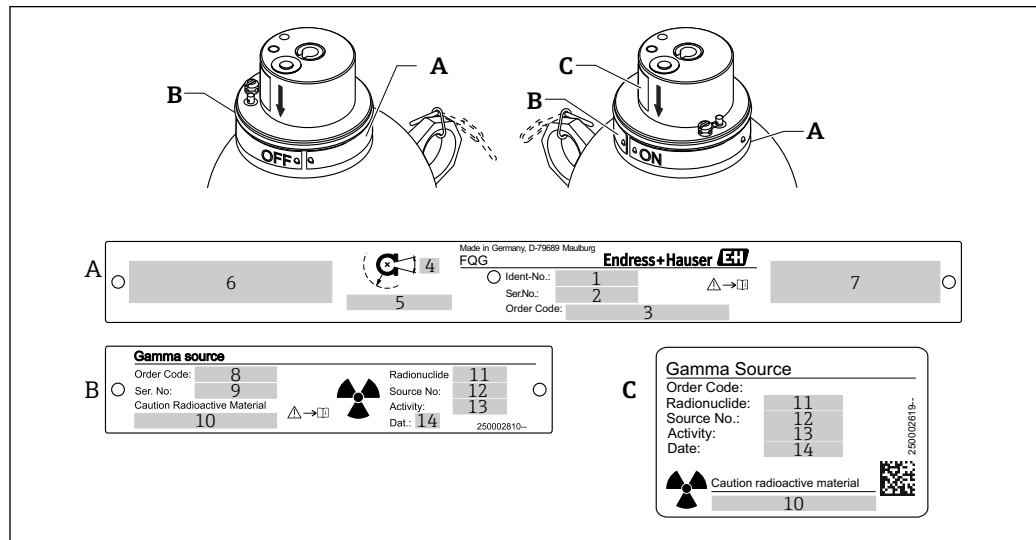

A0018398

- A Nameplate of source container
 B Nameplate of radiation source
 C Additional nameplate of radiation source
 1 ID number of source container
 2 Serial number of source container
 3 Order code of radiation source container according to product structure → 54
 4 Radiation angle of emission
 5 Local dose rate at a defined distance from the surface (when switched off, outside the path of the beam)
 6 Labeling of "OFF" switch position plus additional language (German, French, Swedish, Norwegian, Russian)
 7 Labeling of "ON" switch position plus additional language (German, French, Swedish, Norwegian, Russian)
 8 Internal Endress+Hauser order code for the radiation source
 9 Internal Endress+Hauser serial number for the radiation source
 10 Wording "Caution Radioactive Material", if required
 11 "Cs137" or "Co60"
 12 Serial number of the source capsule (according to supplier certificate)
 13 Activity including unit (MBq or GBq)
 14 Date of loading (month/year)

NOTICE

The local dose rate at a defined distance specified on the nameplate is based on a worst-case estimation if switched off,

- ▶ outside the path of the beam and takes into account production dependent fluctuations of the source activity and tolerances of the measuring devices. Therefore it may be slightly different from the local dose rate which can be calculated from the specified attenuation factors. → 11

FQG61/FQG62; order code 020, option B, C or D → 54

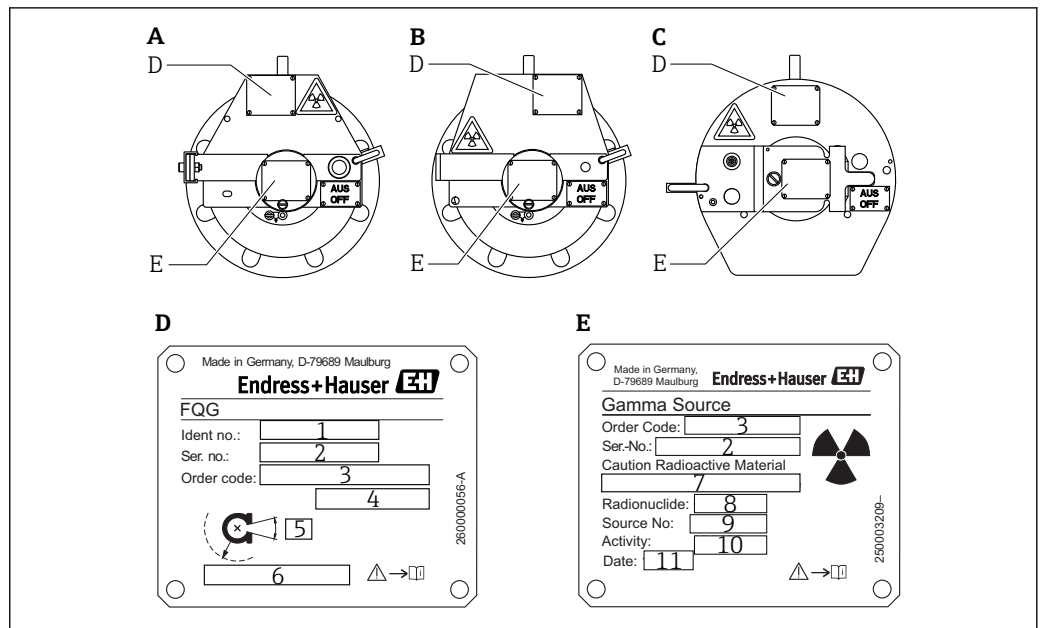

- A FQG61/FQG62; order code 020, option B
 B FQG61/FQG62; order code 020, option C
 C FQG61/FQG62; order code 020, option D
 D Nameplate of source container
 E Nameplate of radiation source
 1 ID number of source container
 2 Serial number of source container
 3 Order code of radiation source container according to product structure → 54
 4 Order code of radiation source container according to product structure → 54
 5 Radiation angle of emission
 6 Local dose rate at a defined distance from the surface (when switched off, outside the path of the beam)
 7 Wording "Caution Radioactive Material", if required
 8 "Cs137" or "Co60"
 9 Serial number of the source capsule (according to supplier certificate)
 10 Activity including unit (MBq or GBq)
 11 Date of loading (month/year)

NOTICE

The local dose rate at a defined distance specified on the nameplate is based on a worst-case estimation if switched off,

- ▶ outside the path of the beam and takes into account production dependent fluctuations of the source activity and tolerances of the measuring devices. Therefore it may be slightly different from the local dose rate which has been calculated from the specified attenuation factors. → 11

FQG61/FQG62; order code 020, option K, L, M or N → 54

Nameplate of source container

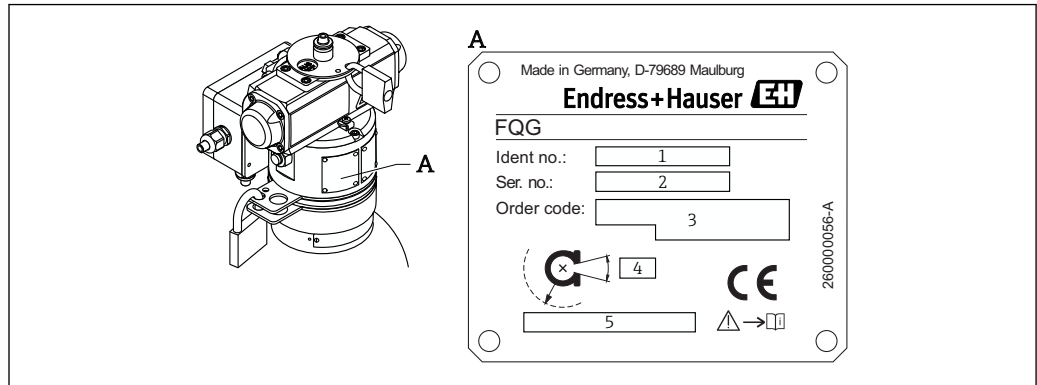

A0034014

9 Nameplate of source container

- 1 ID number of source container
- 2 Serial number of source container
- 3 Order code of radiation source container (product structure)
- 4 Radiation angle of emission
- 5 Local dose rate at a defined distance from the surface (when switched off, outside the path of the beam)

Additional nameplate for Australia

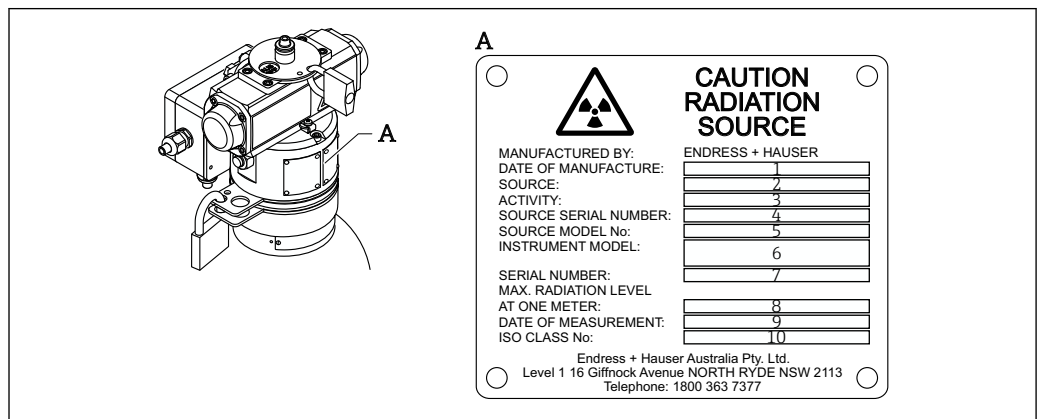

A0034015

10 Additional nameplate for Australia

- 1 Date of manufacture of source
- 2 "Cs137" or "Co60"
- 3 Activity including unit (MBq or GBq)
- 4 Serial number of source
- 5 Order code of radiation source
- 6 Internal Endress+Hauser order code for the radiation source
- 7 Internal Endress+Hauser serial number for the radiation source
- 8 Dose rate at a distance of 1 m (3.3 ft)
- 9 Date of container inspection
- 10 Material class of source

Nameplate of radiation source

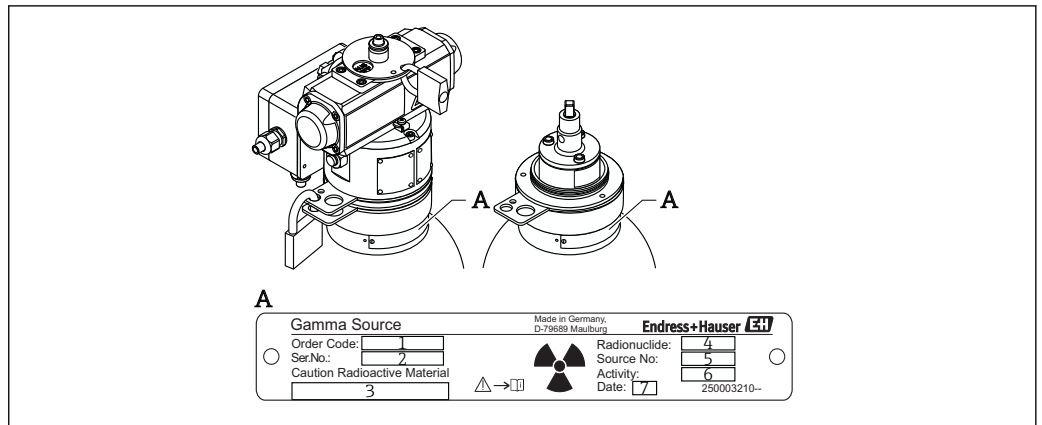

A0034016

11 Nameplate of radiation source

- 1 Internal Endress+Hauser order code for the radiation source
- 2 Internal Endress+Hauser serial number for the radiation source
- 3 Wording "Caution Radioactive Material", if required
- 4 "Cs137" or "Co60"
- 5 Serial number of the source capsule (according to certificate)
- 6 Activity including unit (MBq or GBq)
- 7 Date of loading (month/year)

Additional nameplate of radiation source

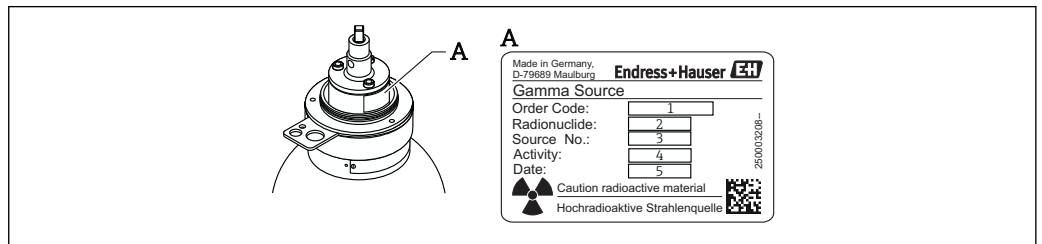

A0034017

12 Additional nameplate of radiation source

- 1 Internal Endress+Hauser order code for the radiation source
- 2 "Cs137" or "Co60"
- 3 Serial number of the source capsule (according to supplier certificate)
- 4 Activity including unit (MBq or GBq)
- 5 Date of loading (month/year)
- 6 Wording "Caution Radioactive Material", if required

Terminal housing nameplate, non-Ex, only for option K, M

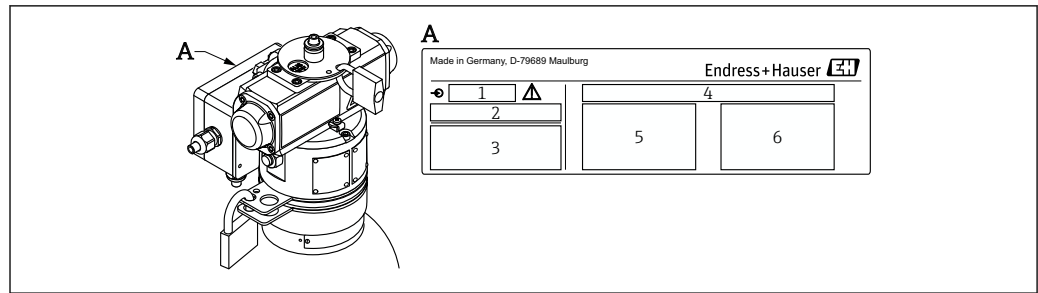

A0034018

13 Terminal housing nameplate, non-Ex, only for option K, M

- 1 Maximum pressure
- 2 Temperature information
- 3 Degree of protection
- 4 NAMUR information
- 5 Circuit diagram ON
- 6 Circuit diagram OFF

Terminal housing nameplate, Ex (ATEX), only for option L, N

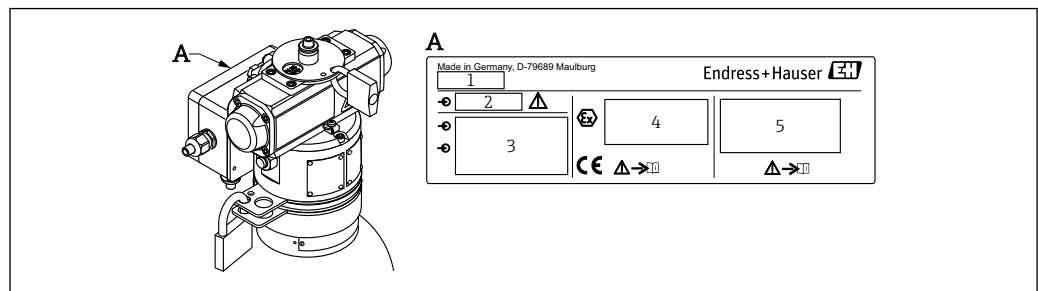

A0034019

14 Terminal housing nameplate, Ex (ATEX), only for option L, N

- 1 Device name
- 2 Maximum pressure
- 3 Terminal assignment
- 4 Ex-related specifications
- 5 Warning sign

NOTICE

The local dose rate at a defined distance specified on the nameplate is based on a worst-case estimation if switched off,

- ▶ outside the path of the beam and takes into account production dependent fluctuations of the source activity and tolerances of the measuring devices. Therefore it may be slightly different from the local dose rate which has been calculated from the specified attenuation factors. → 11

RFID TAG**Operating principle of RFID and NFC**

Radio frequency identification (RFID) makes it possible to identify the measuring point without direct visual contact, and exchanges data between suitable terminal devices. A transponder consists of a microchip, an antenna and a carrier/housing. The digital information is saved in the microchip. Energy is supplied to the microchip during the communication process by the electromagnetic field initiated by the transmitter.

Near field communication (NFC) is an extension of RFID technology and is an international communication standard for wireless data transfer at a frequency of 13.56 MHz. The external power supply and safety standards only allow a short range with a maximum data transmission rate of 423 kBit/s and a connection setup of <0.1 s. The latest NFC technology can be used with NFC-enabled devices.

Passive NFC transponders do not have their own power source (e.g. batteries) and are therefore maintenance-free. They are powered by the electromagnetic field of the transmitter.

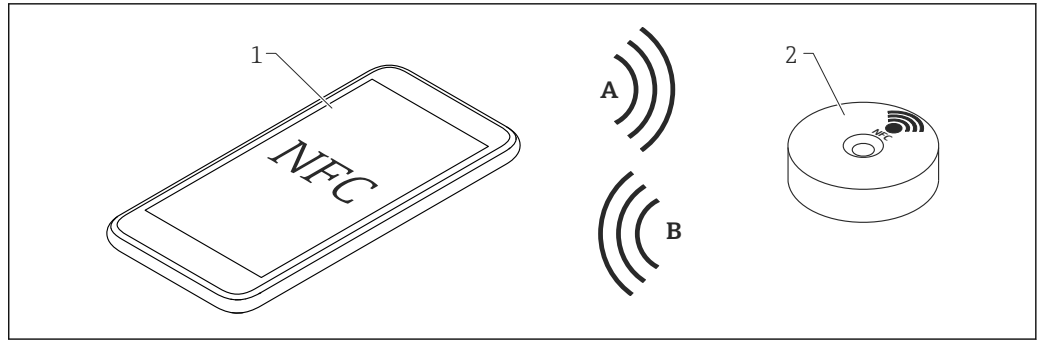

A0026682

15 Operating principle of RFID and NFC

A Data, energy

B Data

1 Mobile device that supports NFC

2 RFID TAG

i The RFID TAGs of the radiation source (FSG60, FSG61) and the radiation source container (FQG61, FQG62) are identical in appearance. The only difference is the data they contain and their location on the device.

For additional information see:

i SD01502F/00 document, which is supplied separately

i ZE01020F/00

Installation

Incoming acceptance

The radiation source container serves as Type-A packaging (IATA rules) for the radiation source. For transportation purposes, it is protected by foam packing in a box.

Package dimensions:

- Without pneumatic actuator: 380 x 380 x 450 mm (15 x 15 x 17.7 in)
- With pneumatic actuator: 380 x 380 x 600 mm (15 x 15 x 23.6 in)

NOTICE

- ▶ The foam packaging can be disposed of as normal household waste

NOTICE

The radioactive warning labels (triangular) must not be removed

- ▶ All other labels can be removed

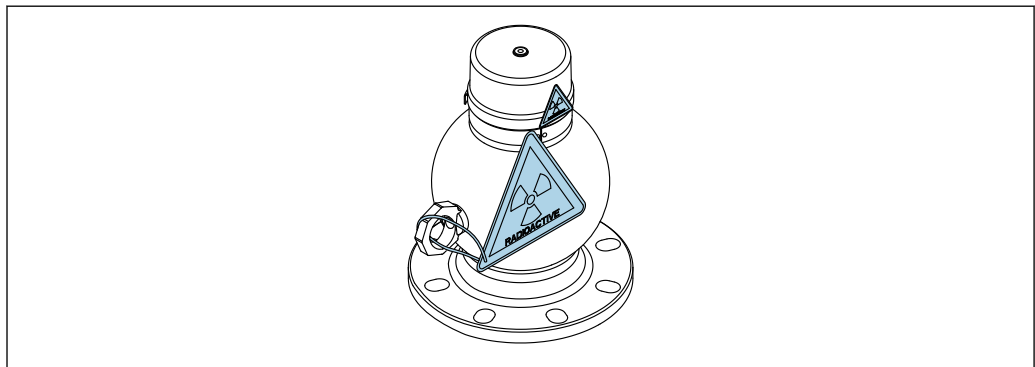

A0037584

Transportation

⚠ WARNING

Risk of injury

- ▶ Transport the radiation source container as illustrated in the graphic below.
- ▶ When using ring straps, the suspension point must be above the center of gravity of the radiation source container. Therefore the additional strap prevents the radiation source container from swinging or tilting.

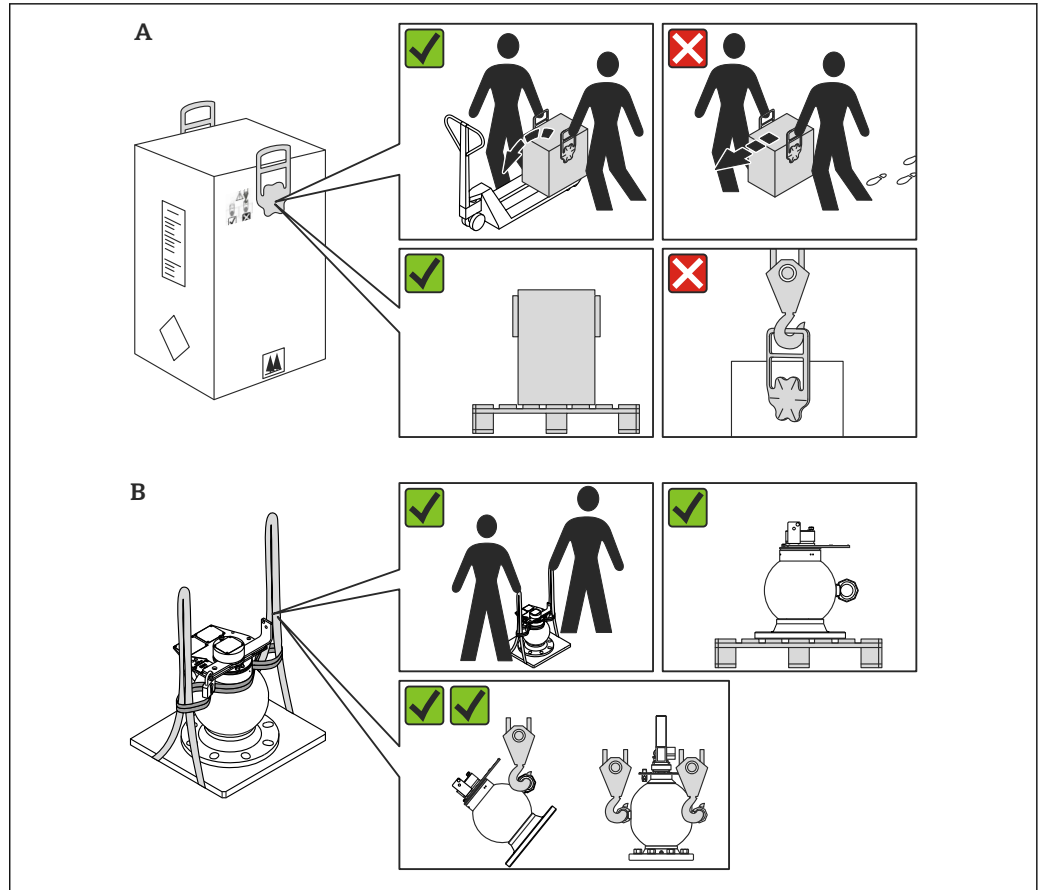

A0022393

A With overpack
B Without overpack

Mounting instructions

The source container can be mounted as follows:

- By a nozzle directly on the vessel or pipe (not pressure-bearing and not in contact with process)
- On an external construction with low to zero vibration

CAUTION

Mounting the source container

- ▶ The source container may only be mounted according to local regulations and/or the handling permit by certified, specially trained personnel whose radiation exposure is monitored. Ensure that this is allowed by the handling permit. All local conditions must be taken into consideration.
- ▶ All work should be carried out as quickly as possible and as far away as possible from the radiation source (screening!). Suitable measures (e.g. blocking of access etc.) must also be taken to protect other individuals from all possible risk.
- ▶ Mounting and removal is only permitted with the switch in the "OFF" position, secured by the padlock.
- ▶ Take the weight of the radiation source container into account when mounting: FQG61: 40 to 50 kg (88.2 to 110.25 lbs), FQG62: 87 to 97 kg (191.84 to 213.89 lbs)

Orientation for level measurement

- ▶ For continuous level measurement, the source container must be mounted at the height of, or slightly above, the maximum level. The radiation must be aligned exactly with the detector mounted on the opposite side. The source container and detector should be mounted as close as possible to the product vessel to avoid control zones.

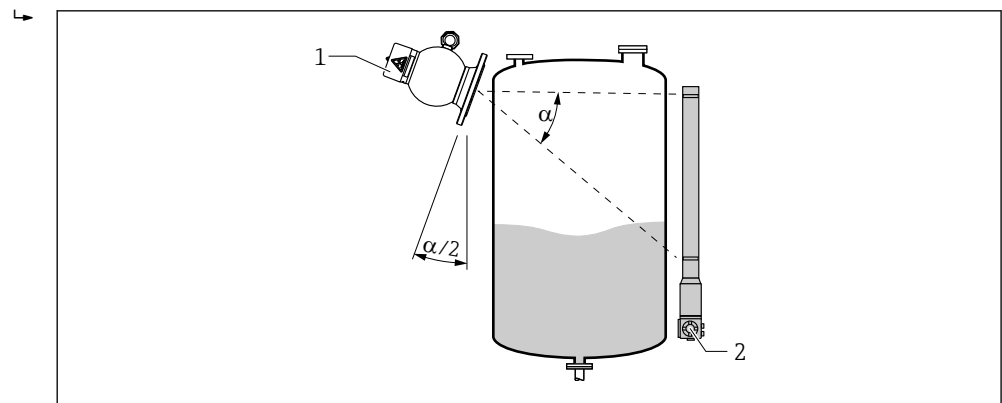

A0018401

- 1 FQG61, FQG62
- 2 FMG60
- α Angle of emission

- ▶ A distance between the source container and the product vessel is often unavoidable if the measuring range is large and the container diameter small. This space must then be secured by grip protection and marked accordingly.

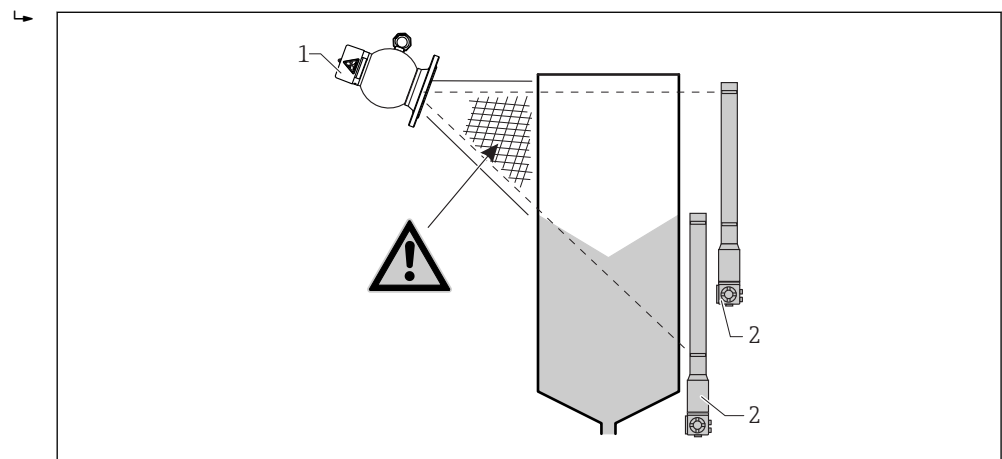

A0018402

- 1 FQG61, FQG62
- 2 FMG60

- ▶ Two or more source containers are generally used for large measuring ranges. The use of several sources can be necessary not only due to large measuring ranges but also for accuracy reasons.

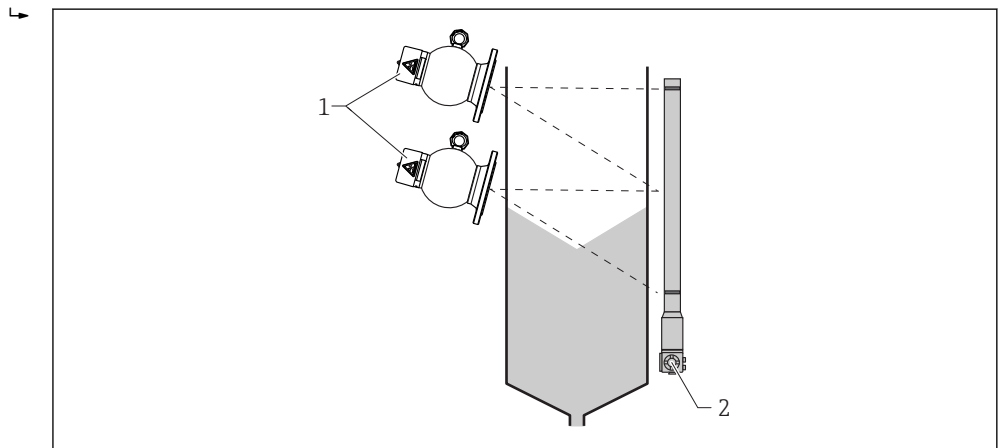

A0018403

- 1 FQG61, FQG62
- 2 FMG60

Orientation for point level detection

- ▶ The version of the source container with an angle of emission of 5° is recommended for point level detection. If larger angles of emission (20° or 40°) are used, make sure that the beam is horizontal. For this purpose, mount the radiation source container in such a way that the eyelet is horizontal.

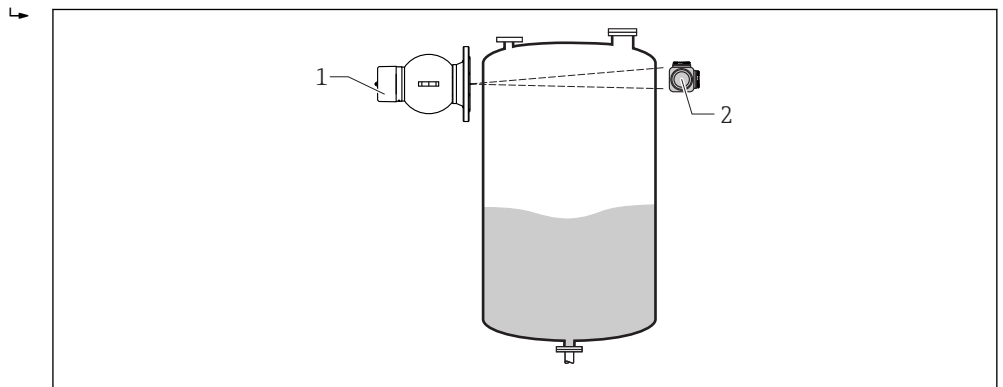

A0018404

- 1 FQG61, FQG62
- 2 FMG60

Orientation for density measurement

- ▶ The most constant conditions for density measurement in pipes are achieved if the unit is mounted on vertical pipelines and the feed direction is from bottom to top. If only horizontal pipes are accessible, the path of the beam should also be arranged horizontally to reduce the influence of air bubbles and buildup. In order to achieve a longer path of the radiation through the medium and thus a better measuring effect, a diagonal beam or a measurement section can be used.

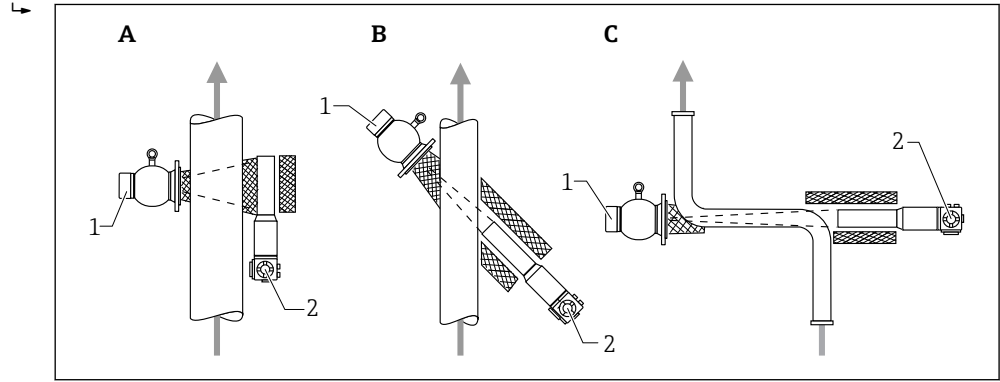

A Vertical beam
 B Diagonal beam
 C Measurement section
 1 FQG61, FQG62
 2 FMG60

The following accessories are available for mounting the radiation source container and the FMG60 compact transmitter on pipes:

- Clamping device FHG61 → 55
- Measurement section FHG62 → 56

Orientation of the fireproof version

Orientation I (recommended)

The source container is mounted with the compensation compartment at the highest point. In the event of fire only the emission channel is sealed by the liquefied lead.

NOTICE

- ▶ After a fire, the screening is slightly reduced in the upper area of the container

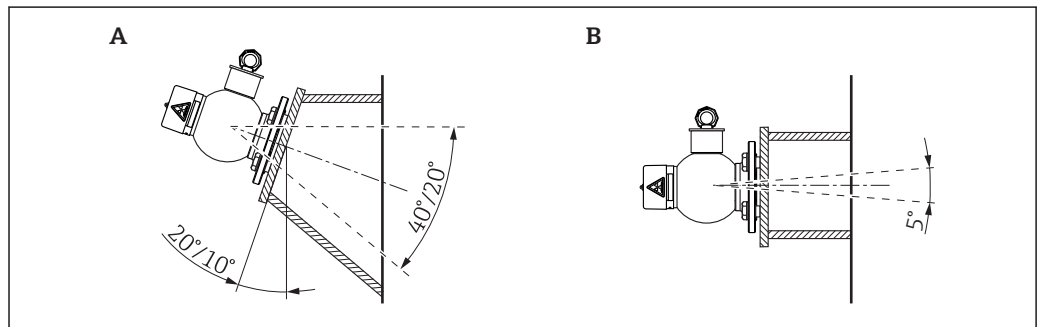

16 Orientation I
 A Level measurement
 B Point level detection

Orientation II (only if orientation I is not possible due to space restrictions)

The source container is mounted with the compensation compartment at the bottom or the side. In the event of fire the emission channel and the compensation compartment are filled with liquefied lead.

NOTICE

- ▶ After a fire, the screening is significantly reduced in the upper area of the source container

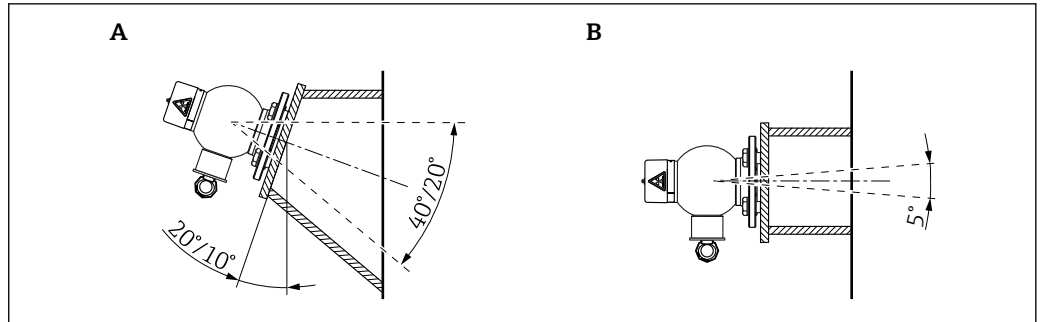

A0018407

17 Orientation II

- A Level measurement
- B Point level detection

Mounting device (supplied by customer)

The source container can be mounted on a mounting plate or L-profiles, for example

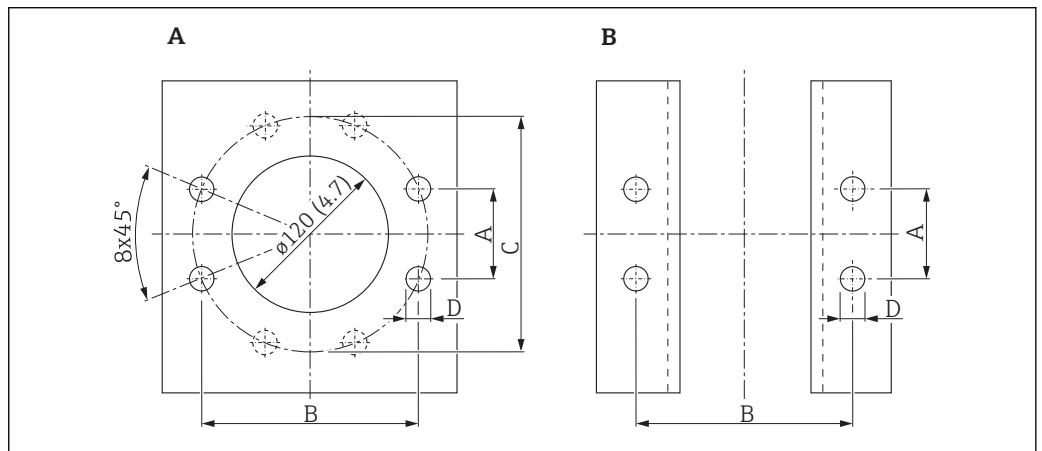

A0018409

- A Example of a mounting plate
- B Example for L-profiles

Dimensions	EN	ANSI
A	68.9 mm (2.71 in)	72.9 mm (2.87 in)
B	166.3 mm (6.55 in)	176.0 mm (6.93 in)
C	180.0 mm (7.09 in)	190.5 mm (7.5 in)
D	18.0 mm (0.71 in)	19.1 mm (0.75 in)

i The mounting flange of FQG61 and FQG62 is compatible with:

- DN 100 PN16
- ANSI 4" 150lbs

Toothed lock washers



Safety instructions

- ▶ Observe the prescribed torque for the mounting screws
- ▶ The mounting screws must have electrical contact to the potential equalization

- ▶ The source container must be integrated in the potential equalization system of the plant. In order to ensure electrical contact between the radiation source container and the mounting support, the supplied toothed lock washers must be used on two of the flange screws as indicated in the adjacent graphic.

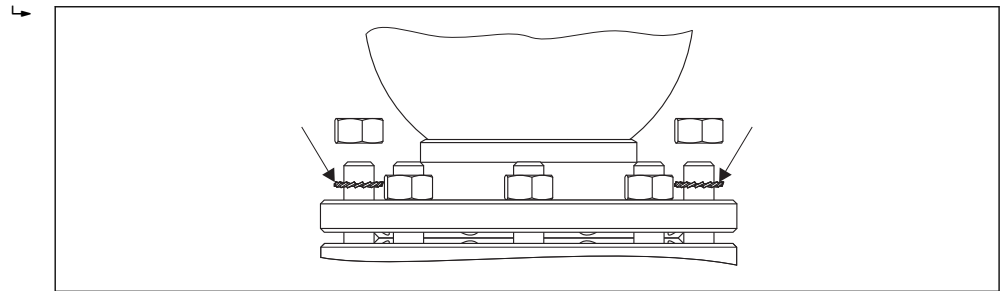

A0018410

18 Mounting the toothed lock washers

Tightening torque for mounting screws

Material	Property class	Coefficient of friction (μ)	Torque
Stainless steel	70	0.14	50 to 140 Nm (36.87 to 103.25 lbf ft)
Steel	8.8	0.14	50 to 140 Nm (36.87 to 103.25 lbf ft)

Post-installation check

Measuring the local dose rate

It is essential to measure the local dose rate in the vicinity of the source container and the detector after mounting and once the radiation source has been installed.

⚠ CAUTION

Depending on the installation, radiation can also occur outside the actual radiation emission channel through scattering.

- ▶ In such cases it must be shielded off by the use of additional lead or steel shielding. Render and mark all control and exclusion areas as prohibited for unauthorized entry.

What to do if the product vessel is empty

⚠ CAUTION

If the vessel is empty, the control area around the vessel must be measured once the unit has been correctly mounted. If necessary, this area must be cordoned off and marked accordingly.

- ▶ If there is an entry into the interior space of the vessel, it must be sealed off and marked with a "radioactive" safety sign.
- ▶ Access can only be permitted by the competent radiation safety officer after he/she has checked all the safety precautions. The source container must be switched off for access to be permitted.
- ▶ The radiation must be switched off if any work is performed in or on the vessel

Connecting the pneumatic actuator

NOTICE

This section only applies to source containers with a pneumatic actuator. (In the product structure: feature 020, versions K, L, M or N)

CAUTION

The pneumatic actuator may only be put into operation once the radiation source container has been mounted

Compressed air connection

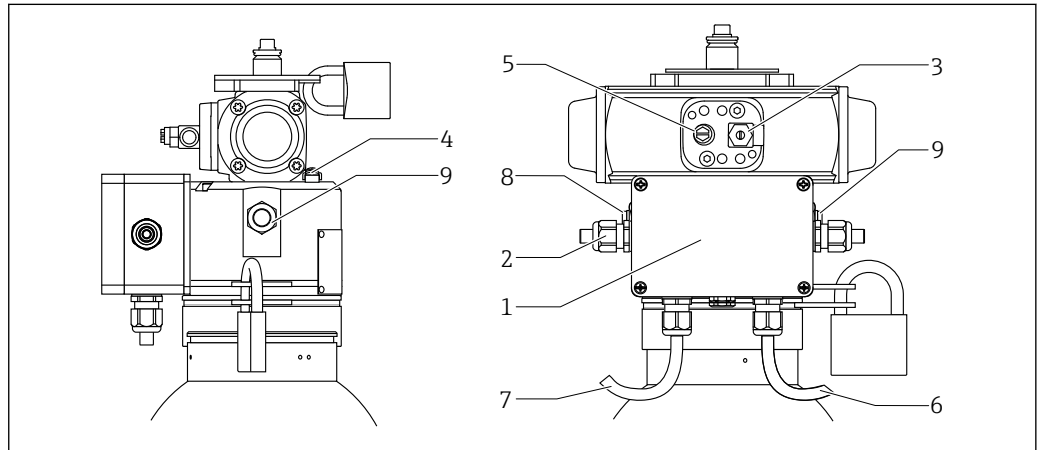

- 1 Terminal box for connection of the proximity switches
- 2 Cable glands for cable diameter 5 to 10 mm (0.2 to 0.4 in)
- 3 Throttle check valve for compressed air connection
- 4 Connection for potential equalization
- 5 Vent filter
- 6 Connecting cable of proximity switch for "AUS/OFF" switch position
- 7 Connecting cable of proximity switch for "EIN/ON" switch position
- 8 Proximity switch for "EIN/ON" switch position
- 9 Proximity switch for "AUS/OFF" switch position

The compressed air line is connected to the throttle check valve.

CAUTION

The throttle check valve is set at the factory and secured with thread locking fluid.

- ▶ Do not change the setting of the throttle check valve.

Connecting the proximity switches

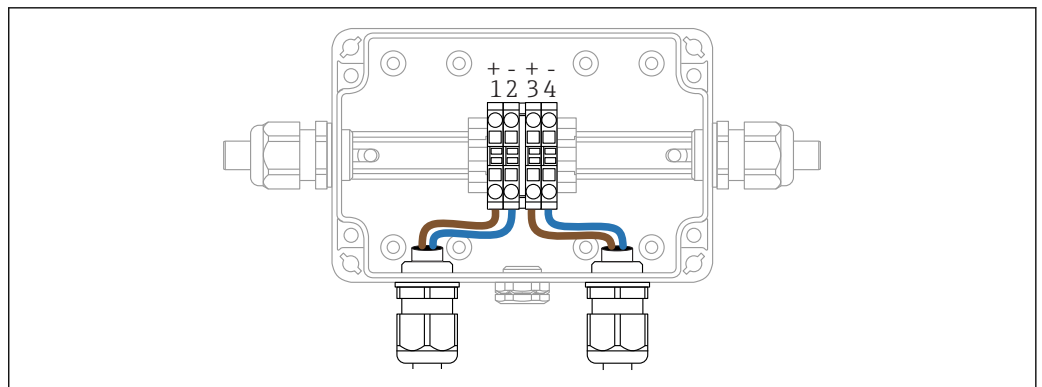

19 Terminal assignment

- 1 Proximity switch for "EIN/ON" switch position, positive lead (brown)
- 2 Proximity switch for "EIN/ON" switch position, negative lead (blue)
- 3 Proximity switch for "AUS/OFF" switch position, positive lead (brown)
- 4 Proximity switch for "AUS/OFF" switch position, negative lead (blue)

Proximity switches

Type model: Pepperl+Fuchs 181094-NCB2-12GM35-NO-10M

Cable entries

Suitable cable diameter: 5 to 10 mm (0.2 to 0.39 in)

Potential equalization

Terminal on the cover →  39

Connection data

- Nominal voltage: 8V
- Current consumption
 - Measuring plate not detected: ≥ 3 mA
 - Measuring plate detected: ≤ 1 mA

Isolating amplifier

The following isolating amplifiers, for example, can be connected for signal evaluation:

- Nivotester FTL325N (Endress+Hauser)
- KFA6-SH-Ex1, 230 V AC (Pepperl+Fuchs)
- KFD2-SH-Ex1, 24 V DC (Pepperl+Fuchs)

Commissioning

Before commissioning, the compressed air supply must be connected for the pneumatic drive and the padlock (1) on the top must be removed. This padlock only needs to be affixed again for revision purposes (OFF position). In the meantime, it should be attached to the second padlock or kept outside the installation. The lower padlock (2) blocks access to the radiation source and must not be removed during normal operation.

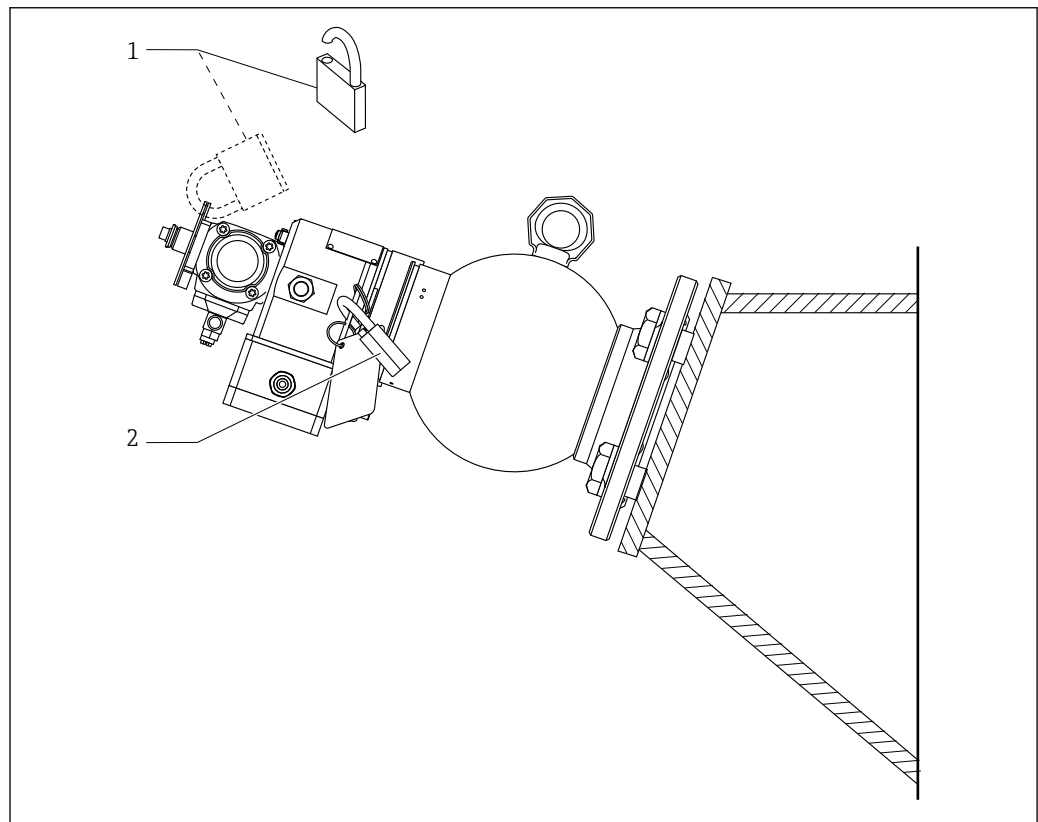

- 1 Padlock for securing the switch position - remove when operating the pneumatic actuator
- 2 Padlock for safeguarding the radiation source - must not be removed during normal operation

Reading the switch state

The current switch state is indicated by the sign that is visible ("EIN - ON" or "AUS - OFF").
The other sign is covered by the rotary disk on the pneumatic switch.

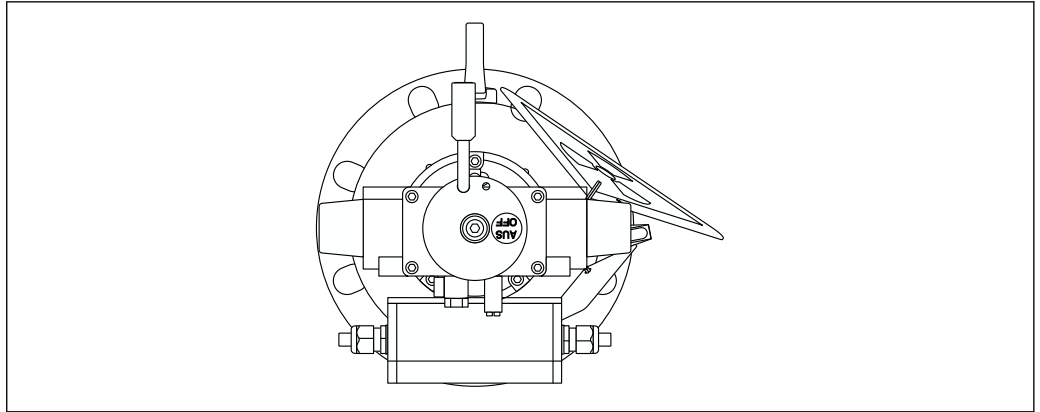

A0018414

20 Switch state

CAUTION

Risk of injury

- ▶ Do not touch the indicator window when the drive is pressurized.

Technical data of the pneumatic actuator

- Swivel range: 180°
- Compressed air connection: G1/8
- Actuating pressure: 3.5 to 6 bar (51 to 87 psi)
- Reset by spring force
- Required compressed air quality: ISO 8573-1 Class 3; maximum particle size 40 µm, pressure dewpoint corresponding to a dewpoint of -20°C or a dewpoint of at least 10 K below ambient temperature

Operation

FQG61/FQG62; order code
020, option A

Switching ON the radiation

⚠ CAUTION

Safety instructions for switching ON the radiation

- ▶ Before switching on the radiation, make sure that no-one is in the radiation zone (or inside the product vessel).
- ▶ The radiation may only be switched ON by properly instructed staff.

Switching ON the radiation

The source container is in the "OFF" position.

1. Press the cover hard against the source container and turn the cover approx. 45° counterclockwise as far as it will go
2. Remove the cover

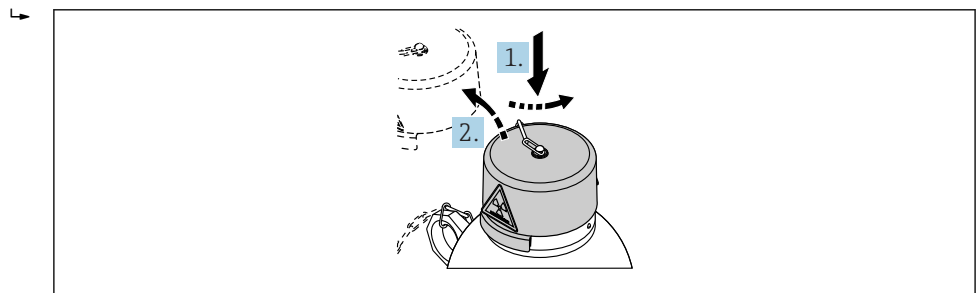

A0018415

3. Using the key, turn the closing cylinder approx. 45° in the counterclockwise direction

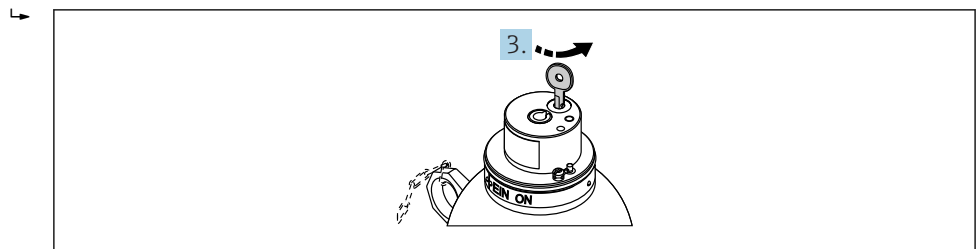

A0039936

4. Pull out the lock until the limit stop.
5. Only for source containers with order code 670 "Additional function", option WA "Density measurement > Fixation ON": release setscrew using Allen key.

6. **⚠ WARNING**

Rotating the insert over the locking pin leads to the removal position of the source insert.

- ▶ Do not press the sealed locking pin (A)

Turn the insert 180° in the counterclockwise direction

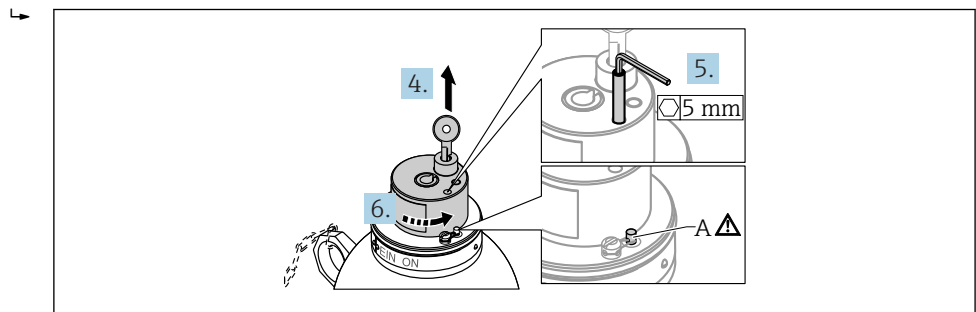

A0039939

7. Press in the cylinder lock with the key and turn it by approx. 45° in the clockwise direction

8. Only for source containers with order code 670 "Additional function", option WA "Density measurement > Fixation ON": screw in setscrew using Allen key. The current switching state is indicated by the arrow (B) ("EIN-ON" or "AUS-OFF").

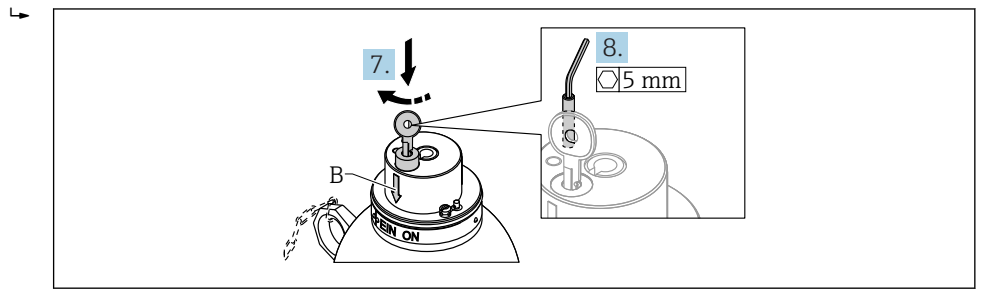

A0033940

9. Put the cover back on. The "EIN-ON" position must be visible.

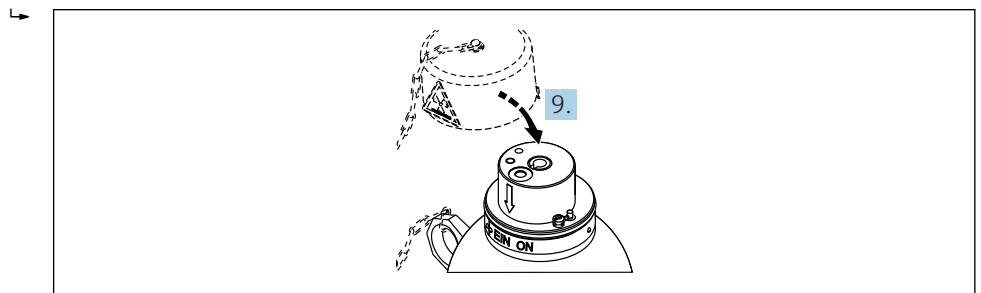

A0033941

Switching OFF the radiation

Proceed in the same way to switch the radiation off. To switch the radiation off, turn the insert 180° in the clockwise direction.

Reading the switch state:

- Radiation ON: the "EIN - ON" sign is visible. The arrow points to "EIN - ON"
- Radiation OFF: the "AUS - OFF" sign is visible. The arrow points to "AUS - OFF"

FQG61/FQG62; order code 020, option B

Switching ON the radiation

CAUTION

Safety instructions for switching ON the radiation

- ▶ Before switching on the radiation, make sure that no-one is in the radiation zone (or inside the product vessel).
- ▶ The radiation may only be switched ON by properly instructed staff.

Switching ON the radiation

WARNING

Do not press the sealed locking pin (B). Rotating the insert over the locking pin leads to the removal position of the source insert.

- ▶ Do not remove the safety bracket (A).

1. Remove the padlock.
2. Release the locking screw (optional).

3. Remove the locking bolt

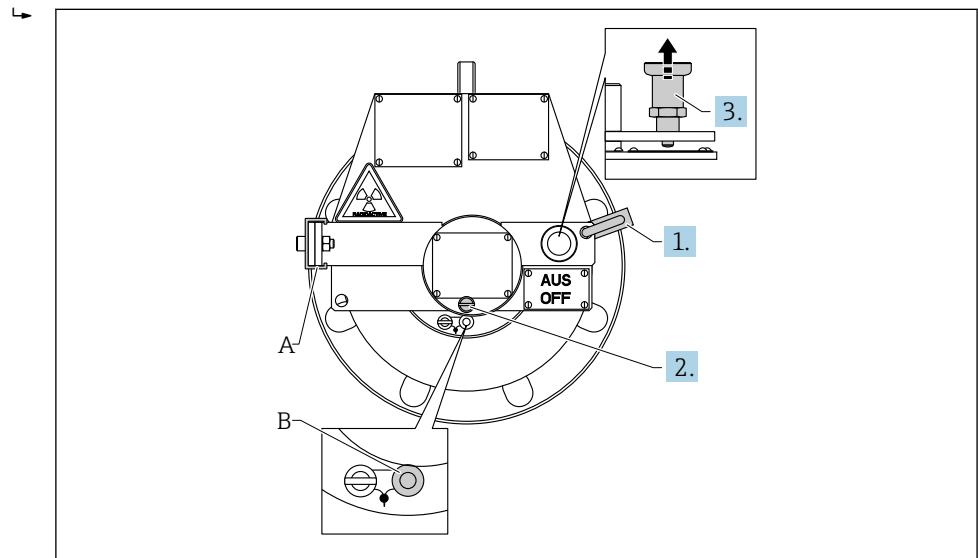

A001B416

4. Turn the swivel bracket 180° in the counterclockwise direction. The current switch state is indicated by the sign that is visible ("EIN - ON" or "AUS - OFF"). The other sign is covered by the swivel bracket.

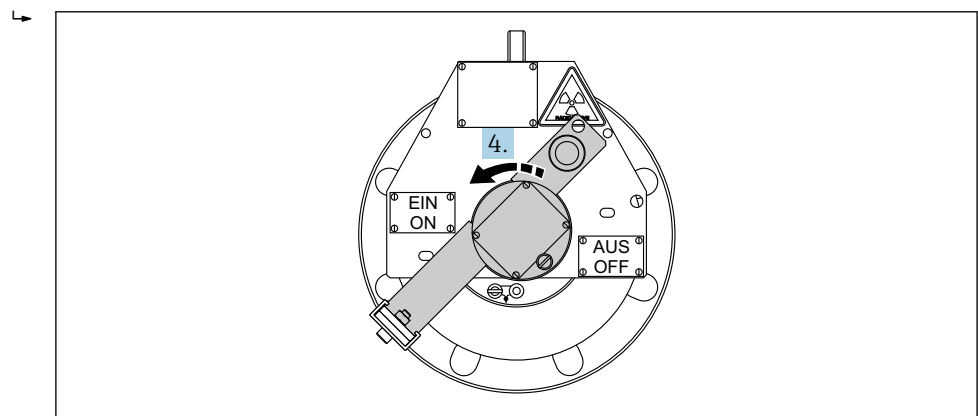

A001B417

5. Fix the padlock in the position provided.
 6. Let the locking bolt snap into place in the "EIN - ON" position. Check that it is locked correctly.
 7. Tighten the locking screw (optional).

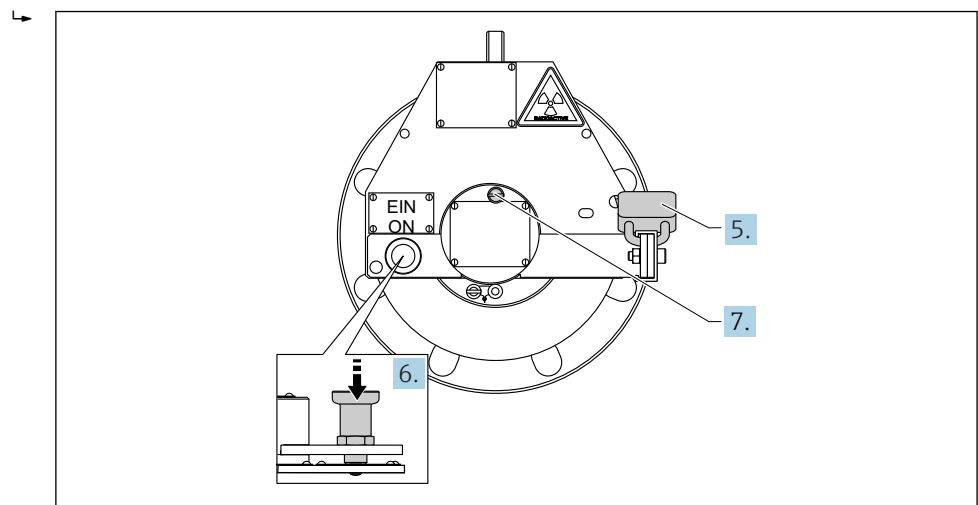

A001B418

Switching OFF the radiation

To switch the radiation OFF, perform the steps above in reverse order.

FQG61/FQG62; order code
020, option C

Switching ON the radiation

⚠ CAUTION

Safety instructions for switching ON the radiation

- ▶ Before switching on the radiation, make sure that no-one is in the radiation zone (or inside the product vessel).
- ▶ The radiation may only be switched ON by properly instructed staff.

Switching ON the radiation

⚠ WARNING

Rotating the insert over the locking pin leads to the removal position of the source insert.

- ▶ Do not press the sealed locking pin (A)

1. Remove the padlock.
2. Release the locking screw (optional).

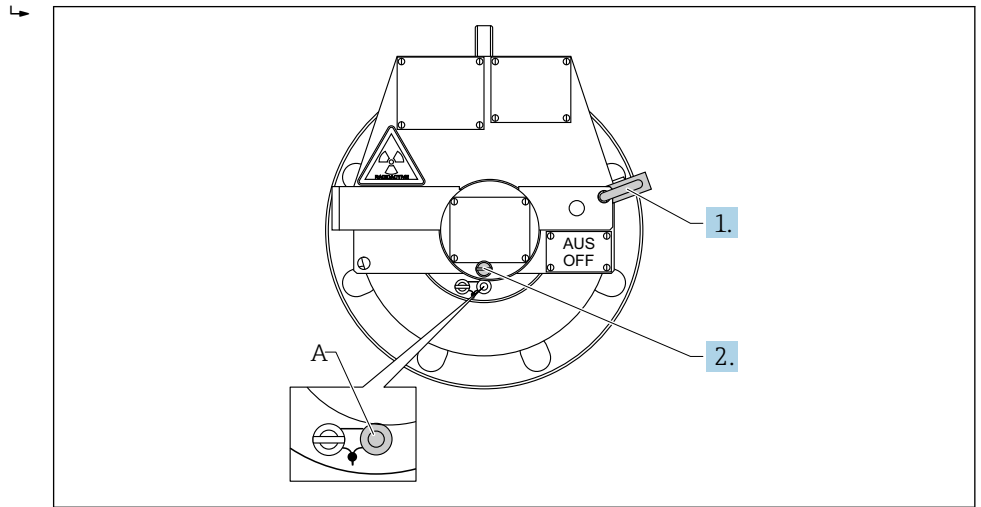

A0018419

3. Turn the swivel bracket 180° in the counterclockwise direction. The current switch state is indicated by the sign that is visible ("EIN - ON" or "AUS - OFF"). The other sign is covered by the swivel bracket.

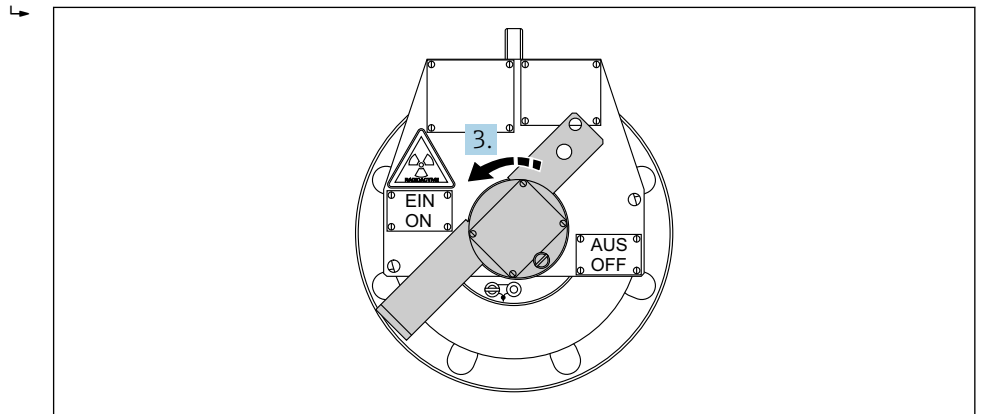

A0018420

4. Secure the "ON" switch position by hooking the padlock into the position provided.

5. Tighten the locking screw (optional)

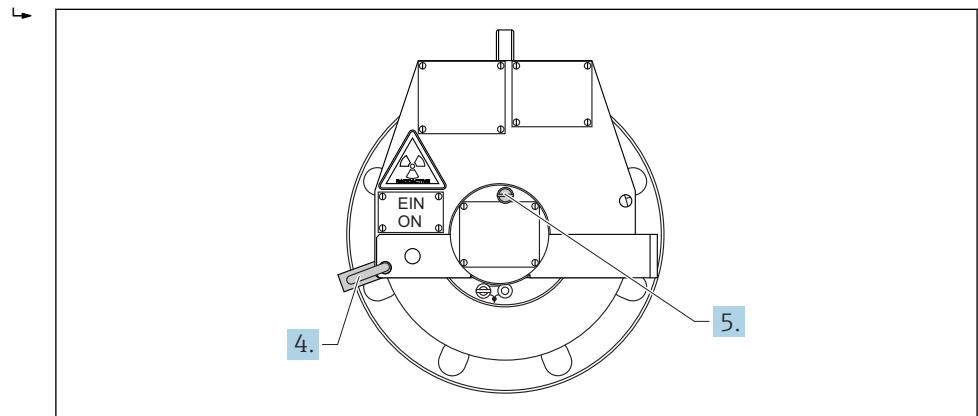

A0018421

Switching OFF the radiation

To switch the radiation OFF, perform the steps above in reverse order.

FQG61/FQG62; order code
020, option D

Switching ON the radiation

⚠ CAUTION

Safety instructions for switching ON the radiation

- ▶ Before switching on the radiation, make sure that no-one is in the radiation zone (or inside the product vessel).
- ▶ The radiation may only be switched ON by properly instructed staff.

Switching ON the radiation

⚠ WARNING

If the bracket is lifted, the source insert can be removed from the source container

- ▶ Do not release the screw (A) and do not lift the swivel bracket (B).

1. Remove the padlock.
2. Release the locking screw (optional).

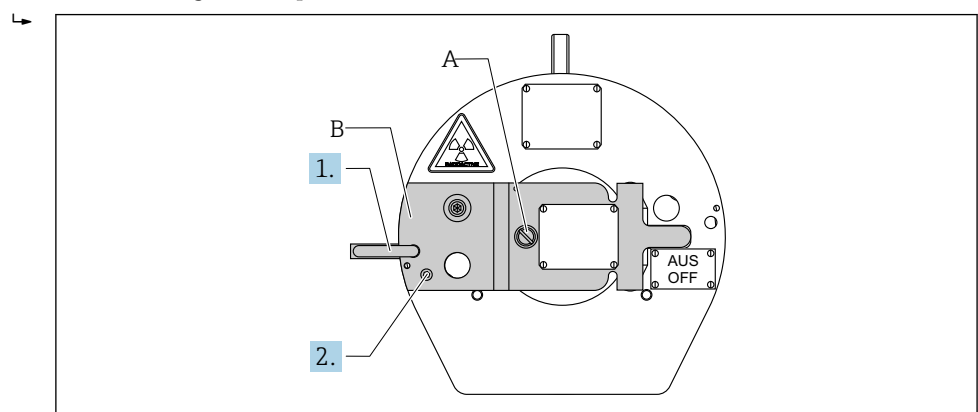

A0018422

3. Turn the swivel bracket 180° in the counterclockwise direction. The current switch state is indicated by the sign that is visible ("EIN - ON" or "AUS - OFF"). The other sign is covered by the swivel bracket.

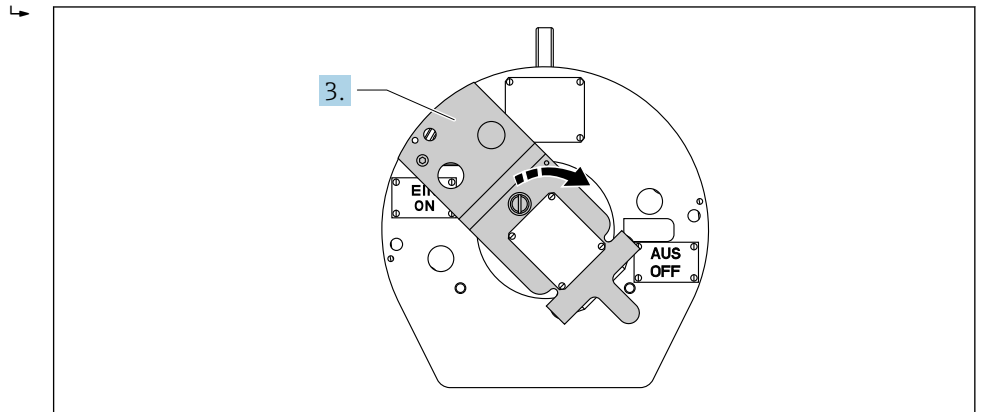

A0018423

4. Secure the "ON" switch position by hooking the padlock into the position provided.
5. Tighten the locking screw (optional)

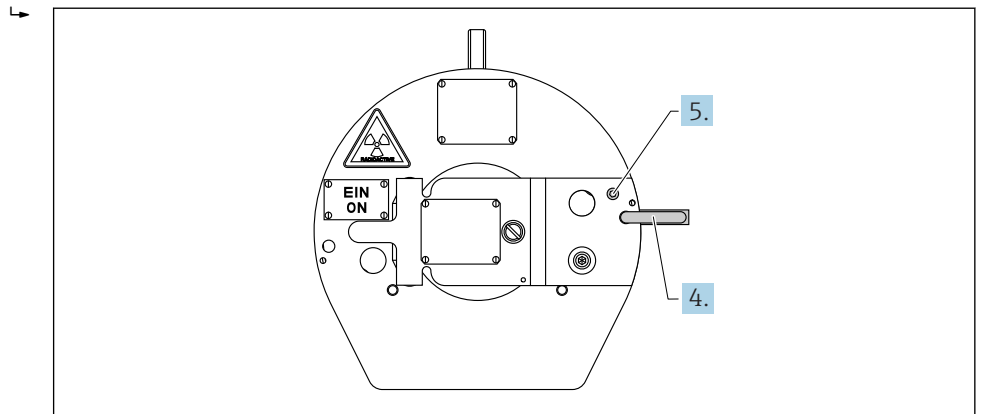

A0018424

Switching OFF the radiation

To switch the radiation OFF, perform the steps above in reverse order.

Maintenance and inspection

Cleaning

Clean the device at regular intervals. When doing so, observe the following:

- Clean the device of substances which impact the safety function
- Keep labels legible
- Clean the adhesive labels and the terminal box (versions with pneumatic actuator) with water and a damp cloth.

CAUTION

When cleaning the device, all safety instructions must be observed

- ▶ →  8

Maintenance and inspection

No device maintenance is required if the device is used as designated and operated under the specified ambient and operating conditions.

The following checks are recommended as part of routine plant inspections:

- Visual inspection for corrosion of the housing, weld seams, outer parts of the source insert and lock(s), toothed lock washers and the reference O-ring
- Check regarding the movability of the source insert (on/off function)
- Inspection of the readability of all labels and the condition of the warning symbols
- Check of the stability and position of the source holder

CAUTION

What to do in the event of irregularities at the source container

- ▶ If there are any doubts about the operational reliability or proper condition of the device, seek immediate advice from the competent radiation safety officer.
- ▶ Non-routine repairs or maintenance must be performed by the manufacturer or distributor or by a person specially authorized to perform the work.

CAUTION

What to do in the event of corrosion



- ▶ If there are clear signs of corrosion at the source container, the local dose rate around the device must be measured. If the value is significantly above the normal operation levels, cordon off the area and notify the radiation safety officer responsible. Corroded devices and toothed lock washers should be replaced as soon as possible in all cases.
- ▶ Source containers with corroded locks or corroded source inserts must be replaced immediately.



The reference O-ring is intended to help check for damage or the influence of aggressive media. Based on the condition of the reference O-ring, conclusions can be drawn regarding the potential condition of the seals inside the source container.

Routine tests of the shutter mechanism

Source containers with manual ON/OFF switching mechanism

1. Release the locking bolt (FQG61/FQG62; order code 020, option B) or remove the padlock (if present) as described in the "Operation" section.
2. Move the source insert several times from ON to OFF and from OFF to ON as described in the "Operation" section (→  42). It should be possible to easily move the source insert and there should not be any visible signs of corrosion:
 - If it is not possible to move the source insert from ON to OFF, follow the instructions in the section "What to do in an emergency" (emergency action).→  51
 - If it is hard to move the source insert or if there are other signs of a malfunction, the source insert must be secured in the "OFF" position and the competent radiation safety officer notified.
 - In the event of corrosion, follow the instructions in the section "Maintenance and inspection" (measures in the event of corrosion).→  48

Source containers with pneumatic ON/OFF switching mechanism

1. Remove the padlock→  40

2. **⚠ WARNING**

Risk of injury

- ▶ Do not reach into the indicator window area of the indicator plate

Using compressed air, switch the source insert from the "OFF" position to the "ON" position. The source insert should move smoothly to the "ON" position without any interruption.

3. Reduce the pressure to below 2.5 bar (36.25 psi). The source insert must move back to the "OFF" position:

- If the source insert does not move continuously or if there are other signs of a malfunction, the source insert must be secured in the "OFF" position and the competent radiation safety officer notified.
- If it is not possible to move the source insert from ON to OFF, follow the instructions in the section "What to do in an emergency" (emergency action). → 51
- In the event of corrosion, follow the instructions in the section "Maintenance and inspection" (measures in the event of corrosion). → 48

Routine leak testing

The capsule enclosing the radiation source must be checked for leaks at regular intervals. The frequency of the leak tests must correspond to the intervals specified by the authority or handling authorization.

i A leak test is not only required as part of routine checks but must also be performed whenever an incident occurs that may impair the casing around the radiation source. In such instances, the leak test procedure must be arranged by the competent radiation safety officer. The applicable regulations must be observed and the test must comprise the source container and all other affected parts of the process vessel. The leak test must be conducted as soon as possible after the incident. The leak test procedure described below is intended for the following situations:

- For routine tests during continuous operation
- When the source container has been in storage for an extended period
- When the source container is to be put back into operation after storage

Leak test procedure

Leak tests must be performed by a person or an organization authorized to provide leak test services, or using a leak test kit that has been provided by an authorized organization. Leak test kits must be used according to the manufacturer's instructions. Records of the leak test results must be retained. Unless otherwise instructed, perform the leak test as follows:

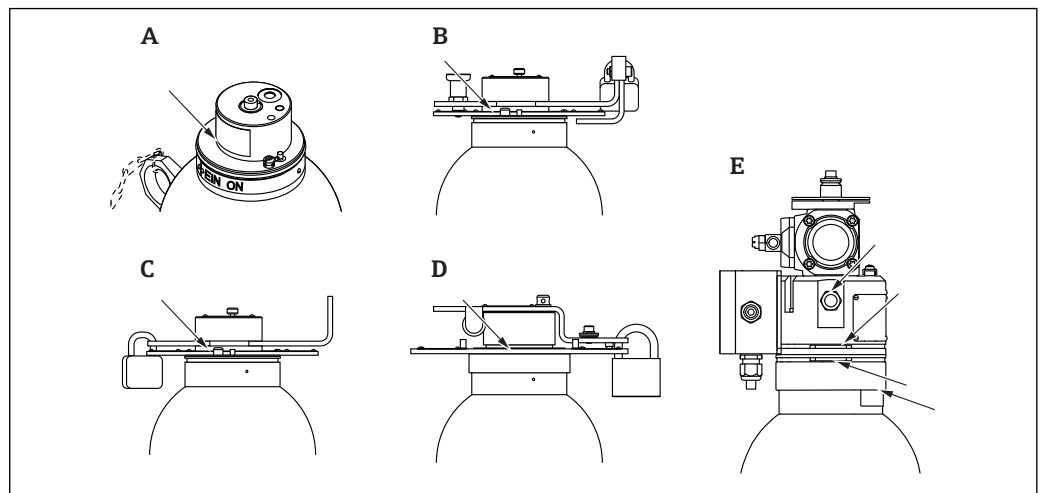

- A FQG61/FQG62; order code 020, option A
- B FQG61/FQG62; order code 020, option B
- C FQG61/FQG62; order code 020, option C
- D FQG61/FQG62; order code 020, option D
- E FQG61/FQG62; order code 020, option K, L, M or N

A0018425

⚠ WARNING**Risk of injury**

- ▶ In the case of source containers with a pneumatic actuator, the switch must be secured and padlocked in the "OFF" position before the wipe test. In the case of manually operated source containers, the wipe test can be performed irrespective of the switch position

- 1. Take a swab sample at the following points at least:
 - ↳ **FQG61/FQG62; order code 020, option A, B, C, D: along the groove between the source insert and the housing**
FQG61/FQG62; order code 020, option K, L, M, N: along the thread of the proximity switches and the three annular grooves on the cylinder housing

- 2. Have the samples analyzed by an authorized organization. A source is considered to be leaking if more than 185 Bq (5 nCi) is detected in the leak test sample.

- i** This limit value applies for the US. National regulations may specify other limits.

If the radiation source is potentially leaking, take the following action:

- Notify the radiation safety officer and follow his/her instructions.
- Take appropriate measures to prevent a potential spread of radioactive contamination from the source. Secure the radiation source.
- Notify the competent authority that a leaking radiation source has been detected.

What to do in an emergency

Emergency action

In the interests of protecting personnel, the emergency procedure described here must be put into effect immediately to secure an area where an exposed radiation source is known, or suspected, to exist.

An emergency exists if a radioisotope has escaped from the source container or if the source holder cannot be set to the "OFF" position. The procedure is designed to safeguard persons affected until the competent radiation safety officer can attend the site and advise on corrective action. The custodian of the radioactive source (i.e. the customer's designated "authorized person") is responsible for observing this procedure.

1. Determine the unsafe area by on-site measurement
2. Cordon off the affected area with yellow tape or rope and post international radiation warning signs.

The source container cannot be switched to the "AUS - OFF" position

In this case, the source container must be unbolted from its mounting position. Point the radiation emission channel towards a thick wall (e.g. steel or lead) or mount a blind flange in front of the emission channel. Individuals should at all times be behind the source container, not in front of the radiation emission channel (flange of FQG61/FQG62). The lifting eye on the housing facilitates safe handling.

The radiation source has escaped from the source container

In this case, the radiation source must be kept secure in another location or additional screening must be provided. The radiation source should only be handled using tongs or a gripper and held as far away from the body as possible. The time needed for the transport should be estimated and minimized by rehearsing without a radiation source prior to execution.

Notifying the competent authority

1. Pass on all the necessary information to the responsible local and national authorities immediately.
2. After a thorough assessment of the situation, the competent radiation safety officer must agree, together with the local authorities, on appropriate corrective measures for the problem.



National regulations may require other procedures and reporting obligations

Procedures after termination of the application

Internal measures

As soon as a radiometric measuring device is no longer required, the radiation source must be switched off on the source container. The source container must be removed in accordance with all relevant regulations and stored in a lockable room having no through-traffic. The competent authorities must be informed of these measures. The access area to the storage room must be measured and marked accordingly. The radiation safety officer is responsible for implementing anti-theft measures. The radiation source in the source container must not be scrapped with the other parts of the plant. It should be returned as quickly as possible.

CAUTION

The source container may only be removed according to local regulations and/or the handling permit by certified, specially trained personnel whose radiation exposure is monitored. Ensure that this is allowed by the handling permit. All local conditions must be taken into consideration. All work should be carried out as quickly as possible and as far away as possible from the radiation source (screening!). Suitable measures (e.g. blocking of access etc.) must also be taken to protect other individuals from all possible risk. The source container may only be removed if the radiation is switched off.

- ▶ Make sure that the OFF position is secured with a padlock.

Return

Federal Republic of Germany

Contact your Endress+Hauser sales center to organize the return of the radiation source for inspection with a view to reuse or recycling by Endress+Hauser.

Other countries

Contact your Endress+Hauser sales center or the appropriate authority to find a way of returning the radiation source in your country. If it is not possible to return the device in your country, the next steps to be taken must be agreed with the Endress+Hauser sales center/representative concerned. The destination airport for any returns is Frankfurt am Main, Germany (FRA).

Conditions

The following conditions must be met before returning the device:

- An inspection certificate no more than three months old and confirming the leak-tightness of the radiation source must be submitted to Endress+Hauser (wipe test certificate). The wipe test can be performed on the source itself or on substitute wipe surfaces as defined in the "Maintenance work" section.
- The serial number of the radiation source, the type of isotope (^{60}Co or ^{137}Cs), the nominal activity and the date of manufacture of the radiation source as per the radiation source certificate must be provided. This information can be found in the documents supplied with the radiation source.
- The container may not show severe signs of corrosion, which could call into question the safe storage of the source.
- The container may not show signs of serious mechanical damage from fire, falls or collisions.
- The "EIN/ON" and "AUS/OFF" mechanism must be in correct working order, as described in the "Operation" section.
- The source container must be secured in the "AUS/OFF" position using the lock pin.
- If there are any doubts about the integrity of the source container, the source must be returned in a separate Type A transportation cask. Contact your Endress+Hauser sales office for this purpose.
- The aforementioned checks must be confirmed in an inspection report. The inspection report must be enclosed when returning the product.
- The transport index must be determined according to TS-R-1 of the IAEA or corresponding national standards. The source container and any secondary packaging must be labeled accordingly.
- The leak test certificate, the manufacturer's certificate for the radiation source and the duly completed pre-return inspection report must be sent to Endress+Hauser in advance before returning the device.

 Following successful inspection, the FQG6x source container is suitable for shipment as a Type A package. The Type A labeling on the radiation source container itself is, however, no longer valid for any subsequent device returns. Before the container is returned, it must be relabeled according to international regulations concerning the transportation of hazardous materials (ADR/RID, DGR/IATA).

Pre-return inspection

Company	
Name	
Address	
Name of inspector and role	

Container	FQG6_ - _____
------------------	---------------

Radiation source	
Isotope	<input type="checkbox"/> ¹³⁷ Cs <input type="checkbox"/> ⁶⁰ Co
Source serial number	
Nominal activity (MBq / GBq)	
Date of manufacture	

Checks	Enter yes or no
Wipe test report not older than 3 months is enclosed with the return shipment documents	
A copy of the manufacturer's certificate of the source is enclosed with the return shipment documents	
No significant signs of corrosion on the container which could put the safe storage of the source at risk	
No signs of serious damage on the container from fire, falls or collisions	
"EIN/ON" and "AUS/OFF" mechanism works according to the Operating Instructions	
The container is in the "AUS/OFF" position and secured with a padlock/lock pin	
The transport index has been determined	
The container is labeled according to international regulations concerning the transportation of hazardous materials (ADR/RID, DGR/IATA)	

Date

Signature

Ordering information

Ordering Information

Detailed ordering information is available as follows:

- In the Product Configurator on the Endress+Hauser website: www.endress.com → Select your country → Products → Select measuring technology, software or components → Select the product (picklists: measurement method, product family etc.) → Device support (right-hand column): Configure the selected product → The Product Configurator for the selected product opens
- at your Endress+Hauser Sales Center: www.addresses.endress.com



Product Configurator - the tool for individual product configuration

- Up-to-the-minute configuration data
- Depending on the device: direct input of information specific to the measuring point, such as measuring range or operating language
- Automatic verification of exclusion criteria
- Automatic generation of the order code with its breakdown in PDF or Excel output format

Scope of delivery

- Source container FQG61 or FQG62
- Radiation source (installed)
- Radiation warning sign
- Technical Information/Operating Instructions: TI00435F/00
- Special Documentation: SD00297F/00 (if unloaded)
- Safety Instructions: SD00292F/00 (for delivery to Canada)
- Operating Instructions: SD00293F/00 (for delivery to the United States)
- Safety Instructions ATEX II 2 G: XA01633F/00

Delivery

Germany

We can only ship radioactive sources once we have received a copy of the handling permit. We are more than happy to assist in procuring the necessary documents. Please contact our local sales center. For safety reasons and to save costs, we usually supply the source container loaded, i.e. with the radiation source installed. If the user requires the source container to be delivered first and if the source must be delivered subsequently, transportation casks are used for shipping.

Other countries

We can only ship radioactive sources once we have received a copy of the import license. Endress+Hauser is more than happy to assist in procuring the necessary documents. Please contact your local sales center.

Radioactive sources must be installed in the source container for delivery abroad.

The source container is in the "OFF" position when the container is delivered. This switch position is secured by a lock. The loaded source containers are transported by a company commissioned by Endress+Hauser and officially certified to perform this type of transportation work.

The unit is transported as a Type A package in compliance with the regulations of the European Agreement on the International Transportation of Hazardous Substances on Roads (ADR and DGR/IATA).

Accessories

Clamping device FHG61

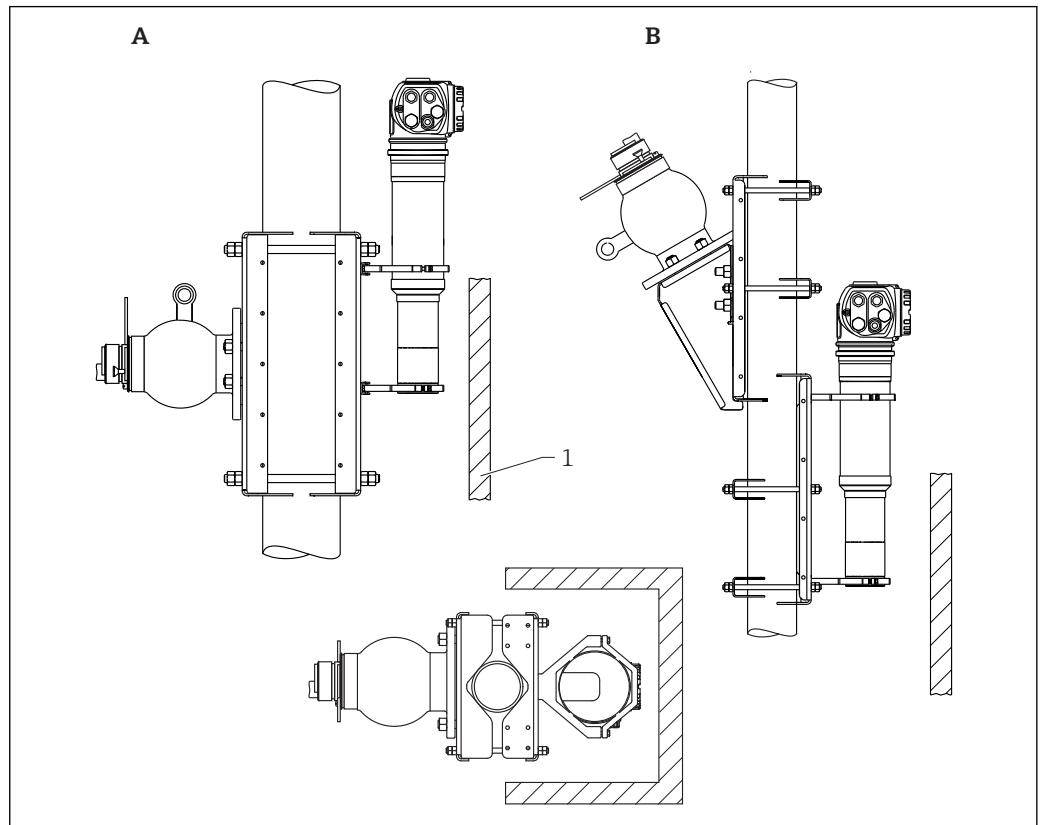

A0018426

- A Radial beam
 B Diagonal beam 30°
 1 Additional screening if required

Ordering information

Detailed ordering information is available as follows:

- For the allocation of the device version, see the Product Configurator on the Endress+Hauser website: www.endress.com → Select your country → Products → Select measuring technology, software or components → Select the product (picklists: measurement method, product family etc.) → Device support (right-hand column): Configure the selected product → The Product Configurator for the selected product opens

- at your Endress+Hauser Sales Center: www.addresses.endress.com



Product Configurator - the tool for individual product configuration

- Up-to-the-minute configuration data
- Depending on the device: direct input of information specific to the measuring point, such as measuring range or operating language
- Automatic verification of exclusion criteria
- Automatic generation of the order code with its breakdown in PDF or Excel output format



For details, see document SD01221F/00

Measurement section FHG62

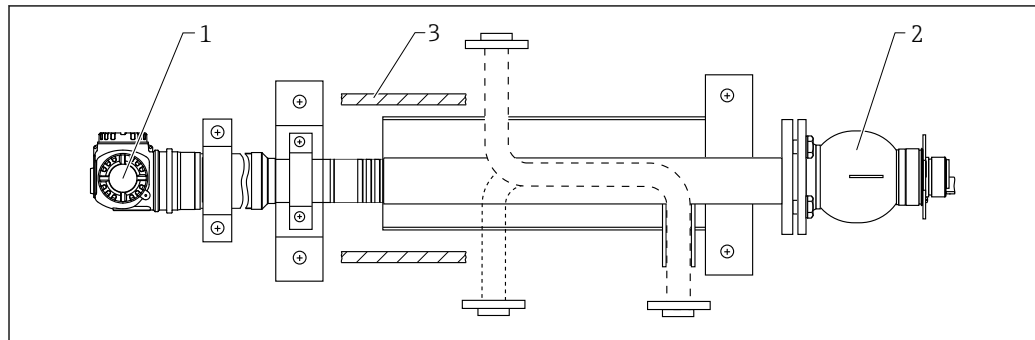

A0018427

- 1 FMG60
- 2 FQG61/FQG62
- 3 Additional screening if required

Ordering information

Detailed ordering information is available as follows:

- For the allocation of the device version, see the Product Configurator on the Endress+Hauser website: www.endress.com → Select your country → Products → Select measuring technology, software or components → Select the product (picklists: measurement method, product family etc.) → Device support (right-hand column): Configure the selected product → The Product Configurator for the selected product opens
- at your Endress+Hauser Sales Center: www.addresses.endress.com



Product Configurator - the tool for individual product configuration

- Up-to-the-minute configuration data
- Depending on the device: direct input of information specific to the measuring point, such as measuring range or operating language
- Automatic verification of exclusion criteria
- Automatic generation of the order code with its breakdown in PDF or Excel output format



For details, see document SD00540F/00



71456915

www.addresses.endress.com