



Level



Pressure



Flow



Temperature



Liquid
Analysis



Registration



Systems
Components



Services



Solutions

Brief Operating Instructions

Cerabar S

PMC71, PMP71, PMP75

Process pressure measurement

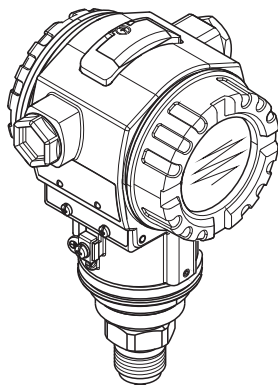

These Instructions are Brief Operating Instructions; they are not a substitute for the Operating Instructions pertaining to the device.

Detailed information about the device can be found in the Operating Instructions and the other documentation:

Available for all device versions via:

- Internet: www.endress.com/deviceviewer
- Smart phone/tablet: *Endress+Hauser Operations App*

KA01019P/00/EN/16.14
71270342

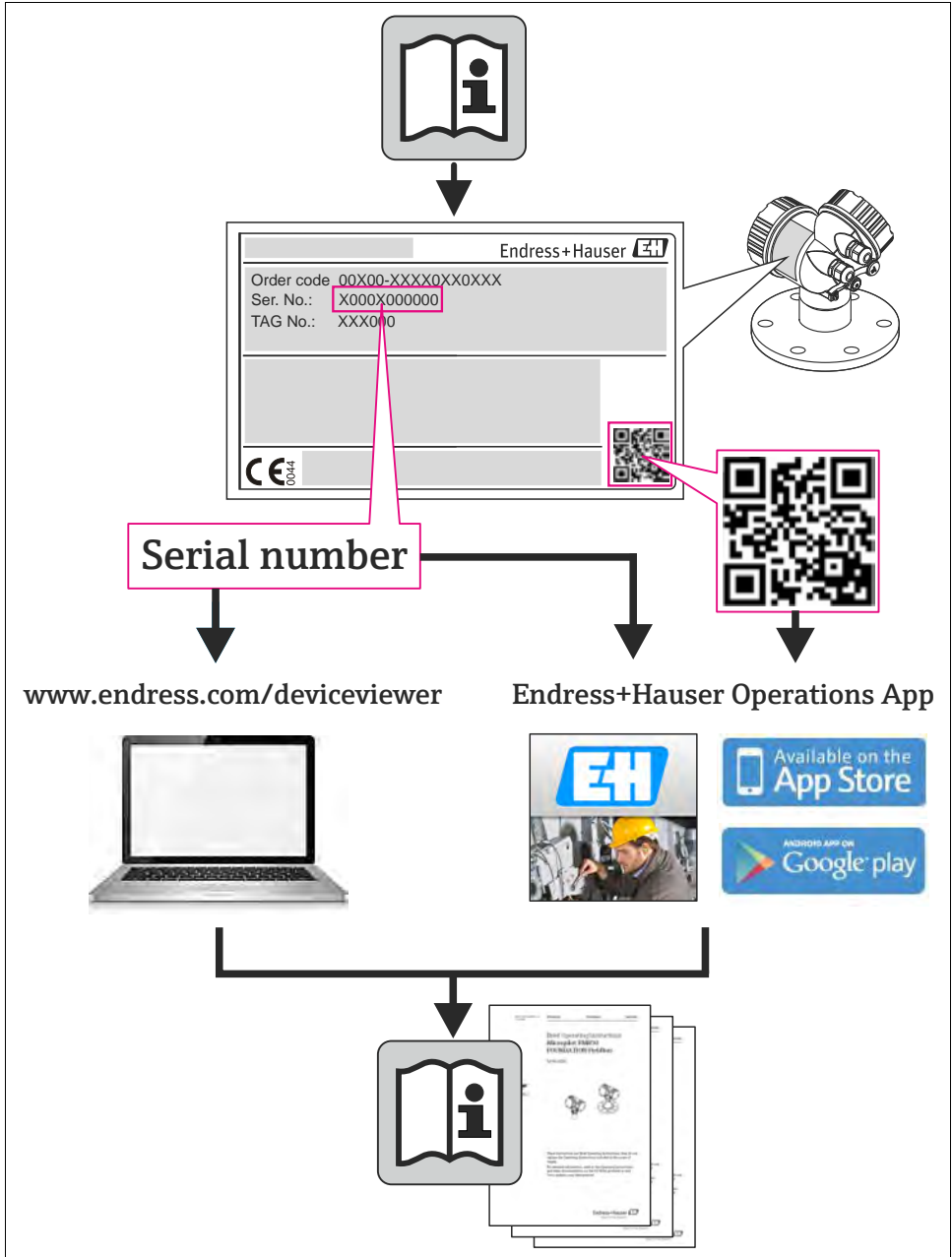

A0023555

Table of contents

1	Safety instructions	4
1.1	Designated use	4
1.2	Installation, commissioning and operation	4
1.3	Operational safety and process safety	4
1.4	Return	4
1.5	Safety icons	5
2	Product identification	5
3	Installation	5
3.1	General installation instructions	5
3.2	Installation instructions for devices without diaphragm seals	PMP71, PMC71 6
3.3	Installation instructions for devices with diaphragm seals	PMP75 8
3.4	Assembling and mounting the "separate housing" version	10
4	Wiring	11
4.1	Connecting the device	11
4.2	Connecting the measuring unit	12
5	Operation	14
5.1	On-site display (optional)	14
5.2	Operating elements	16
5.3	On-site operation via on-site display	19
5.4	Locking/unlocking operation	23
6	Commissioning	24
6.1	Position adjustment	25
6.2	Pressure measurement	26
6.3	Level measurement	29

1 Safety instructions

1.1 Designated use

The Cerabar S is a pressure transmitter for measuring pressure and level.

The manufacturer accepts no liability for damages resulting from incorrect use or use other than that designated.

1.2 Installation, commissioning and operation

- The device must only be installed, connected, commissioned and maintained by qualified and authorized specialists (e.g. electrical technicians) in full compliance with the instructions in this manual, the applicable norms, legal regulations and certificates (depending on the application).
- The specialist must have read and understood this manual and must follow the instructions it contains. If you are unclear on anything in these Brief Operating Instructions, you must read the Operating Instructions. The Operating Instructions provide detailed information on the device/measuring system.
- The device may only be modified or repaired if such work is expressly permitted in the Operating Instructions.
- If faults cannot be rectified, the device must be taken out of service and secured against unintentional commissioning.
- Do not operate damaged devices. Mark them as defective.



1.3 Operational safety and process safety

- Alternative monitoring measures must be taken to ensure operational safety and process safety during configuration, testing and maintenance work on the device.
- The device is safely built and tested according to state-of-the-art technology and has left the factory in perfect condition as regards technical safety. The applicable regulations and European standards have been taken into account.
- Pay particular attention to the technical data on the nameplate.
- Devices for use in hazardous areas are fitted with an additional nameplate. If the device is to be installed in an explosion hazardous area, then the specifications in the certificate as well as all national and local regulations must be observed. The device is accompanied by separate "Ex documentation", which is an integral part of this Operating Instructions. The installation regulations, connection values and Safety Instructions listed in this Ex document must be observed. The documentation number of the related Safety Instructions is also indicated on the additional nameplate.
- If using devices for applications with safety integrity level, the separate manual on functional safety must be observed thoroughly.

1.4 Return

Follow the instructions on returning the device as outlined in the Operating Instructions.

1.5 Safety icons

Symbol	Meaning
	Warning! A warning highlights actions or procedures which, if not performed correctly, will lead to personal injury, a safety hazard or destruction of the instrument.
	Caution! Caution highlights actions or procedures which, if not performed correctly, may lead to personal injury or incorrect functioning of the instrument.
	Note! A note highlights actions or procedures which, if not performed correctly, may indirectly affect operation or may lead to an instrument response which is not planned.

2 Product identification

The following options are available for identification of the measuring device:

- Nameplate specifications
- Order code with breakdown of the device features on the delivery note
- Enter serial numbers from nameplates in W@M Device Viewer (www.endress.com/deviceviewer): All information about the measuring device is displayed.

For an overview of the technical documentation provided, enter the serial number from the nameplates in the W@M Device Viewer (www.endress.com/deviceviewer).

3 Installation

3.1 General installation instructions



Warning!

The process seal is not allowed to press on the process isolating diaphragm as this could affect the measurement result.

**Note!**

- If a heated Cerabar S is cooled during the cleaning (e.g. by cold water), a vacuum develops for a short time, whereby water can penetrate the sensor through the pressure compensation (1). If this is the case, mount the sensor with the pressure compensation (1) pointing downwards.

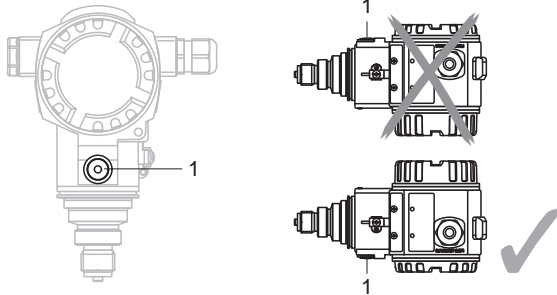

- Keep the pressure compensation and GORE-TEX® filter (1) free from contaminations.
- Do not clean or touch process isolating diaphragm of the diaphragm seals with hard or pointed objects.
- Due to the orientation of the Cerabar S, there may be a shift in the measured value, i.e. when the container is empty, the measured value does not display zero. You may correct this zero point shift either directly on the device using the "E"-key or by remote operation. → See Page 16, Section "Position of operating elements", Page 17, Section 4.2.2 "Function of the operating elements" and Page 25, Section 5.1 "Position adjustment".
- For PMP75, please refer to Section 2.3 "Installation instructions for devices with diaphragm seals", Page 8.
- The PMC71 High temperature version and the PMP75 must only be insulated up to a certain height.
- To ensure optimal readability of the on-site display, it is possible to rotate the housing up to 380°.
- The onsite display can be rotated in 90° stages.
- Endress+Hauser offers a mounting bracket for installing on pipes or walls.

3.2 Installation instructions for devices without diaphragm seals PMP71, PMC71

Cerabar S without diaphragm seal are mounted as per the norms for a manometer (DIN EN 837-2). We recommend the use of shut-off devices and siphons. The orientation depends on the measuring application.

3.2.1 Pressure measurement

Pressure measurement in gases

- Mount Cerabar S with shut-off device above the tapping point so that any condensate can flow into the process.

Pressure measurement in steams

- Mount Cerabar S with siphon below the tapping point. The siphon reduces the temperature to almost ambient temperature.
- Fill the siphon with fluid before commissioning.

Pressure measurement in liquids

- Mount Cerabar S with shut-off device below or at the same level as the tapping point.

3.2.2 Level measurement

- Mount Cerabar S below the lowest measuring point.
- Do not mount the device at the following positions:
In the fill flow, in the tank outlet or at a point in the container which could be affected by pressure pulses from an agitator.
- The calibration and functional test can be carried out more easily if you mount the device after a shut-off device.

3.3 Installation instructions for devices with diaphragm seals PMP75



Note!

- The diaphragm seal, together with the pressure transmitter, forms a closed, calibrated system, which is filled through openings in the diaphragm seal and in the measurement system of the pressure transmitter. These openings are sealed and must not be opened.
- Do not remove the protection of the process isolating diaphragm until shortly before installation.
- When using a mounting bracket, sufficient strain relief must be ensured for the capillaries in order to prevent the capillary bending down (bending radius ≥ 100 mm).
- Please note that the hydrostatic pressure of the liquid column in the capillary can cause zero point shift. The zero point shift can be corrected. → See Page 16, Section "Position of operating elements", Page 17, Section 4.2.2 "Function of the operating elements" and Page 25, Section 5.1 "Position adjustment".
- Please note the application limits of the diaphragm seal filling oil as detailed in the Technical Information for TI00383P, Section "Planning instructions for diaphragm seal systems" or at "www.endress.com/applicator".

In order to obtain more precise measurement results and to avoid a defect in the device, mount the capillaries as follows:

- vibration-free (in order to avoid additional pressure fluctuations)
- not in the vicinity of heating or cooling lines
- insulate if the ambient temperature is below or above the reference temperature
- with a bending radius of ≥ 100 mm.

3.3.1 Vacuum application

For applications under vacuum, Endress+Hauser recommends mounting the pressure transmitter underneath the diaphragm seal. A vacuum load of the diaphragm seal caused by the presence of filling oil in the capillary is hereby prevented.

When the pressure transmitter is mounted above the diaphragm seal, the maximum height difference H_1 in accordance with the illustration below on the left must not be exceeded. The maximum height difference is dependent on the density of the filling oil and the smallest ever pressure that is permitted to occur at the diaphragm seal (empty container), see illustration below, on the right.

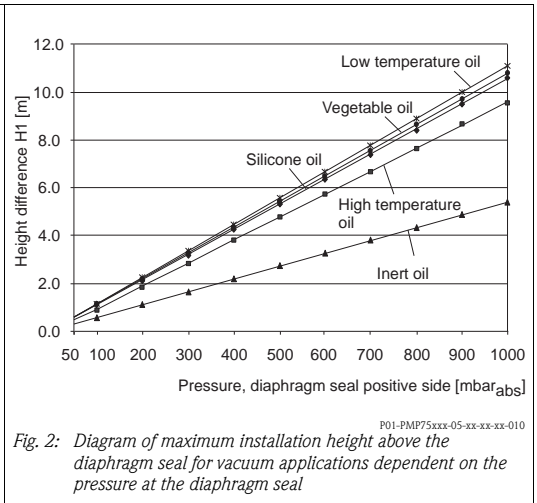
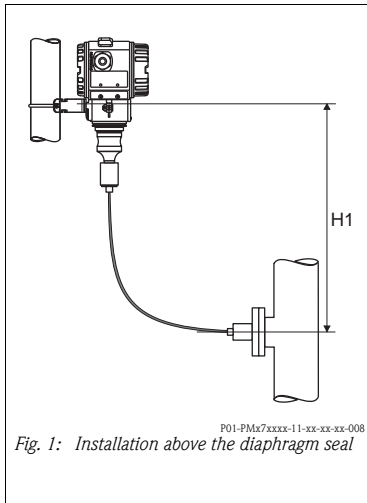

3.4 Assembling and mounting the "separate housing" version

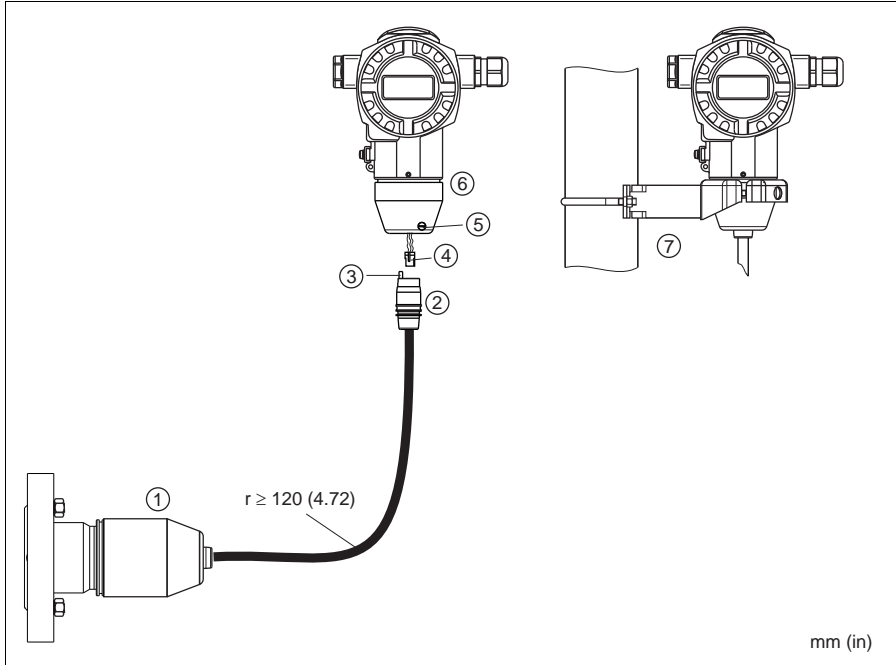

P01-PMx7xxxx-11-xx-xx-xx-011

Fig. 3: "Separate housing" version

- 1 In the "separate housing" version, the sensor is supplied with process connection and cable fitted.
- 2 Cable with connection jack
- 3 Pressure compensation
- 4 Plug
- 5 Locking screw
- 6 Housing fitted with housing adapter, included
- 7 Mounting bracket suitable for wall and pipe mounting, included

Assembly and mounting

1. Connect plug (item 4) into the corresponding connection jack of the cable (item 2).
2. Plug the cable into the housing adapter (item 6).
3. Tighten the locking screw (item 5).
4. Mount the housing on a wall or pipe using the mounting bracket (item 7). When mounting on a pipe, tighten the nuts on the bracket uniformly with a torque of at least 5 Nm.
Mount the cable with a bending radius (r) ≥ 120 mm.

4 Wiring

4.1 Connecting the device



Warning!

Risk of electric shock!

If the operating voltage is > 35 VDC: Dangerous contact voltage at terminals.

In a wet environment, do not open the cover if voltage is present.



Warning!

Limitation of electrical safety due to incorrect connection!

- Risk of electric shock and/or explosion in hazardous areas! In a wet environment, do not open the cover if voltage is present.
- When using the measuring device in hazardous areas, installation must comply with the corresponding national standards and regulations and the Safety Instructions or Installation or Control Drawings.
- Devices with integrated overvoltage protection must be earthed.
- Protective circuits against reverse polarity, HF influences and overvoltage peaks are installed.
- The supply voltage must match the supply voltage on the nameplate.
- Switch off the supply voltage before connecting the device.
- Remove housing cover of the terminal compartment.
- Guide cable through the gland. Preferably use twisted, screened two-wire cable.
- Connect device in accordance with the following diagram.
- Screw down housing cover.
- Switch on supply voltage.

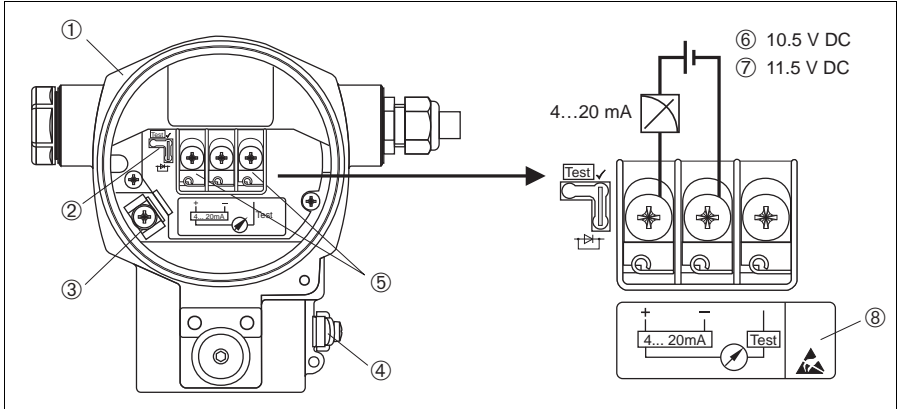

P01-2Mx7xxxx-04-xx-xx-xx-001

Fig. 4: Electrical connection 4...20 mA HART → Observe also the following section.
For devices with Harting Han7D or M12 plug see Operating Instructions.

- 1 Housing
- 2 Jumper for 4...20 mA test signal. → See also the following section.
- 3 Internal earth terminal
- 4 External earth terminal
- 5 4...20 mA test signal between plus and test terminal
- 6 Minimum supply voltage = 10.5 V DC, jumper is inserted in accordance with the illustration.
- 7 Minimum supply voltage = 11.5 V DC, jumper is inserted in "Test" position.
- 8 Devices with integrated overvoltage protection are labelled OVP (overvoltage protection) here.

4.2 Connecting the measuring unit

4.2.1 Supply voltage and taking 4...20 mA test signal

Jumper position for test signal	Description
	<ul style="list-style-type: none"> - Taking 4...20 mA test signal via plus and test terminal: possible. (Thus, the output current can be measured without interruption via the diode.) - Delivery status - minimum supply voltage (at the terminals): 11.5 V DC
	<ul style="list-style-type: none"> - Taking 4...20 mA test signal via plus and test terminal: not possible. - minimum supply voltage (at the terminals): 10.5 V DC

4.2.2 Cable specification

- Endress+Hauser recommends using twisted, screened two-wire cables.
- Terminals for wire cross-sections 0.5...2.5 mm²
- Cable external diameter: 5...9 mm

4.2.3 Screening/potential matching

- You achieve optimum screening against disturbances if the screening is connected on both sides (in the cabinet and on the device). If you have to reckon with potential equalisation currents in the plant, only earth screening on one side, preferably at the transmitter.
- When using in hazardous areas, you must observe the applicable regulations. Separate Ex documentation with additional technical data and instructions is included with all Ex systems as standard.

5 Operation

5.1 On-site display (optional)

A 4-line liquid crystal display (LCD) is used for display and operation. The on-site display shows measured values, dialog texts, fault messages and notice messages.





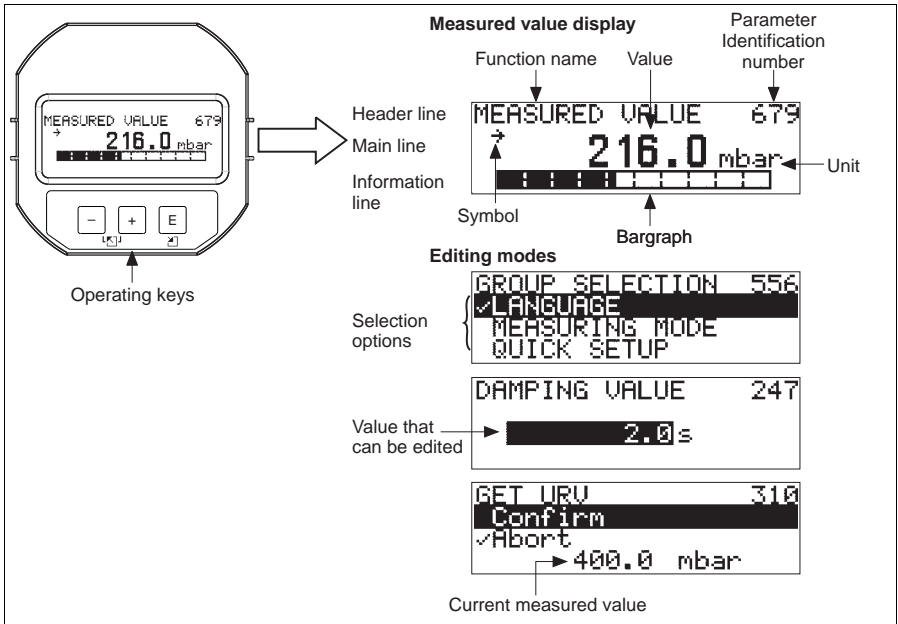

The display of the device can be turned in 90° steps.

Depending on the installation position of the device, this makes it easy to operate the device and read the measured values.



P01-xMx7xxxx-07-xx-xx-xx-001

The following table illustrates the symbols that can appear on the on-site display. Four symbols can occur at one time.

Symbol	Meaning
	Alarm symbol – Symbol flashing: warning, device continues measuring. – Symbol permanently lit: error, device does not continue measuring. <i>Note:</i> The alarm symbol may overlie the tendency symbol.
	Lock symbol The operation of the device is locked. Unlock device, → see Page 23, Section 4.4.
	Communication symbol Data transfer via communication
	Tendency symbol (increasing) The measured value is increasing.
	Tendency symbol (decreasing) The measured value is decreasing.
	Tendency symbol (constant) The measured value has remained constant over the past few minutes.

5.2 Operating elements

5.2.1 Position of operating elements

With regard to aluminium housings and stainless steel housing (T14), the operating keys are located either outside the device under the protection cap or inside on the electronic insert. In hygienic stainless steel housings (T17), the operating keys are always located inside on the electronic insert. Additionally, three operating keys are located on the optional on-site display.

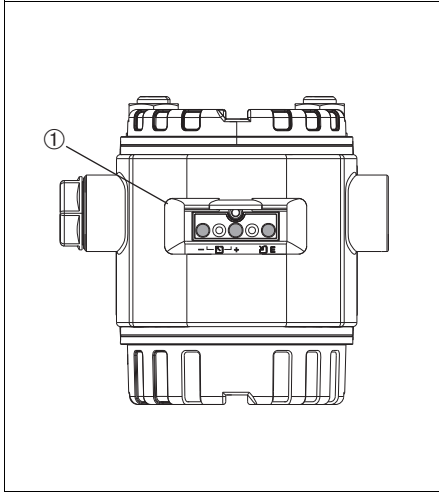

Fig. 5: Operating keys, external

P01-PMx7xxxx-19-xx-xx-xx-009

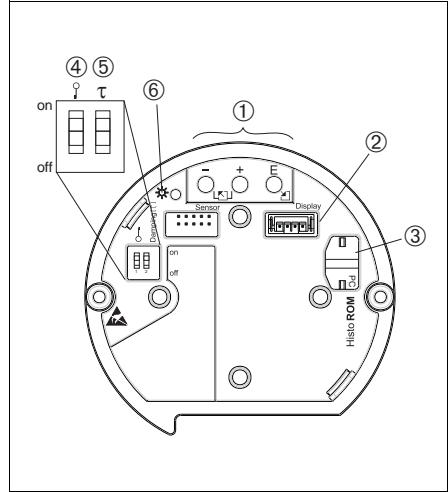

Fig. 6: Operating keys, internal







P01-xxxxxxx-19-xx-xx-xx-104

- 1 Operating keys on the exterior of the device under the protective flap



- 1 Operating keys
 2 Slot for optional display
 3 Slot for optional HistoROM® / M-DAT
 4 DIP-switch for locking/unlocking measured-value-relevant parameters
 5 DIP-switch for damping on/off
 6 Green LED to indicate value being accepted

5.2.2 Function of the operating elements – on-site display not connected

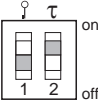
Press and hold the key or the key combination for at least 3 seconds to execute the corresponding function. Press the key combination for at least 6 seconds for a reset.

Operating key(s)	Meaning
	Adopt lower range value. A reference pressure is present at the device. → See also Page 28, Section 5.2.2 "Pressure measuring mode" or Page 31, Section 5.3.2 "Level measuring mode".
	Adopt upper range value. A reference pressure is present at the device. → See also Page 28, Section 5.2.2 "Pressure measuring mode" or Page 31, Section 5.3.2 "Level measuring mode".
	Position adjustment
	Reset all parameters. The reset via operating keys corresponds to the software reset code 7864.
	Copy the configuration data from the optional HistoROM®/M-DAT module to the device.
	Copy the configuration data from the device to the optional HistoROM®/M-DAT module.
 <small>P01-xxxxxxx-19-xx-xx-xx-057</small>	<ul style="list-style-type: none"> – DIP-switch 1: for locking/unlocking measured-value-relevant parameters Factory setting: off (unlocked) – DIP-switch 2: damping on/off, Factory setting: on (damping on)

5.2.3 Function of the operating elements – on-site display connected

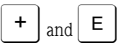
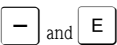
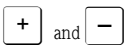
Operating key(s)	Meaning
	<ul style="list-style-type: none"> - Navigate upwards in the picklist - Edit the numerical values and characters within a function
	<ul style="list-style-type: none"> - Navigate downwards in the picklist - Edit the numerical values and characters within a function
	<ul style="list-style-type: none"> - Confirm entry - Jump to the next item
	<p>Contrast setting of on-site display: darker</p>
	<p>Contrast setting of on-site display: brighter</p>
	<p>ESC functions:</p> <ul style="list-style-type: none"> - Exit edit mode without saving the changed value. - You are in a menu within a function group. The first time you press the keys simultaneously, you go back a parameter within the function group. Each time you press the keys simultaneously after that, you go up a level in the menu. - You are in a menu at a selection level. Each time you press the keys simultaneously, you go up a level in the menu. <p><i>Note:</i> The terms function group, level and selection level are explained in Section 4.3.1, Page 19.</p>

5.3 On-site operation via on-site display

5.3.1 Structure of the operating menu

The menu is split into four levels. The three upper levels are used to navigate while you use the bottom level to enter numerical values, select options and save settings.

→ For the entire menu see CD-ROM, Operating Instructions BA00271P.

The structure of the OPERATING MENU depends on the measuring mode selected, e.g. if the "Pressure" measuring mode is selected, only the functions necessary for this mode are displayed.

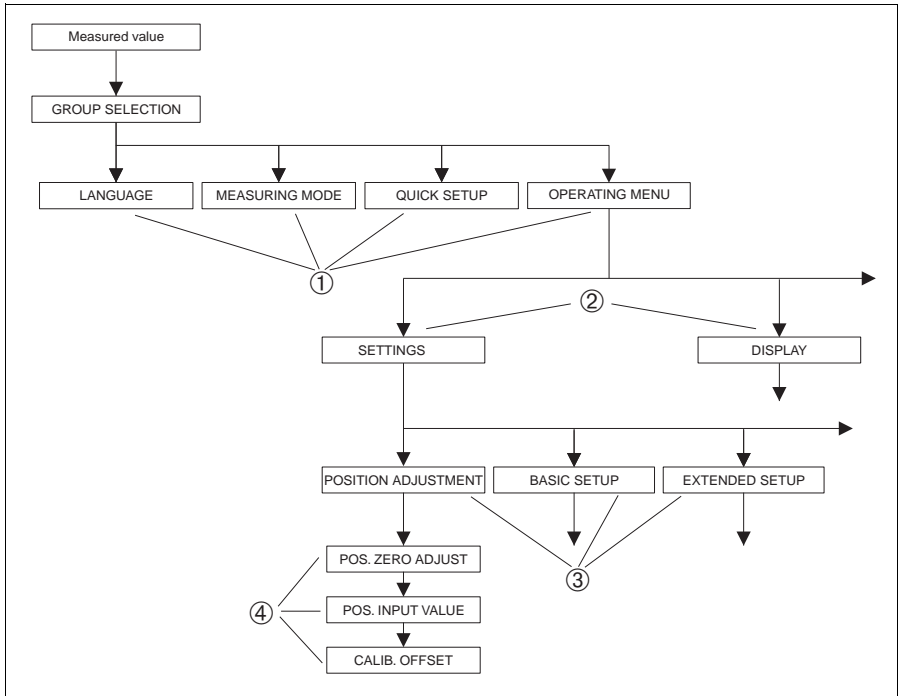

P01-xxxxxxx-19-xx-xx-xx-145

Fig. 7: Structure of the operating menu

- 1 Selection level
- 2 Selection level
- 3 Function groups
- 4 Parameter

5.3.2 Selecting an option

Example: select "English" as the language of the menu.

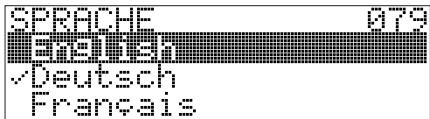
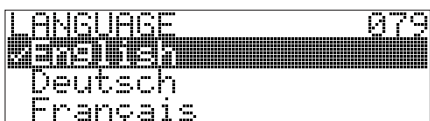
On-site display	Operation
 <p style="text-align: right; font-size: small;">P01-xxxxxxx-19-xx-xx-xx-017</p>	<p>German is selected as the language. A ✓ in front of the menu text indicates the active option.</p>
 <p style="text-align: right; font-size: small;">P01-xxxxxxx-19-xx-xx-xx-033</p>	<p>Select English with "+" or "-".</p>
 <p style="text-align: right; font-size: small;">P01-xxxxxxx-19-xx-xx-xx-034</p>	<ol style="list-style-type: none"> 1. Confirm your choice with "E". A ✓ in front of the menu text indicates the active option. (English is now selected as the menu language.) 2. Jump to the next item with "E".

5.3.3 Editing a value

Example: adjusting DAMPING VALUE function from 2.0 s to 30.0 s. → See also Page 18, Section 4.2.3 "Function of the operating elements".

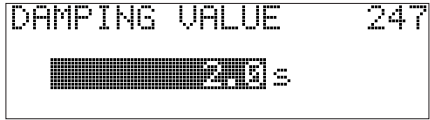
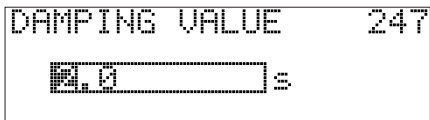
On-site display	Operation
 <p style="text-align: right; font-size: small;">P01-xxxxxxx-19-xx-xx-xx-023</p>	<p>The on-site display shows the parameter to be changed. The value highlighted in black can be changed. The "s" unit is fixed and cannot be changed.</p>
 <p style="text-align: right; font-size: small;">P01-xxxxxxx-19-xx-xx-xx-027</p>	<ol style="list-style-type: none"> 1. Press "+" or "-" to get to the editing mode. 2. The first digit is highlighted in black.

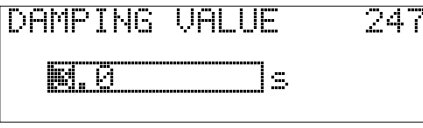
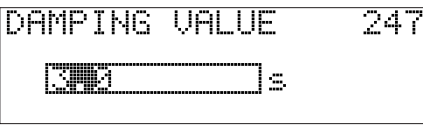
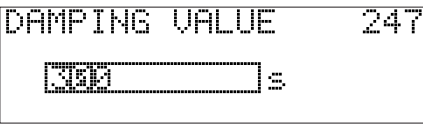
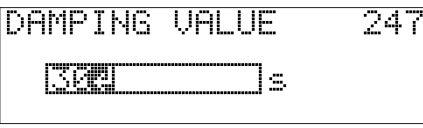
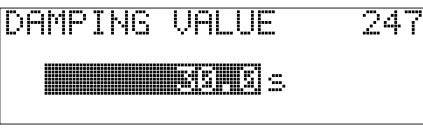
On-site display	Operation
 <p style="text-align: right; font-size: small;">P01-xxxxxxxx-19-xx-xx-xx-028</p>	<ol style="list-style-type: none"> 1. Use "+" to change "2" to "3". 2. Confirm "3" with "E". The cursor jumps to the next position (highlighted in black).
 <p style="text-align: right; font-size: small;">P01-xxxxxxxx-19-xx-xx-xx-029</p>	<p>The decimal point is highlighted in black, i.e. you can now edit it.</p>
 <p style="text-align: right; font-size: small;">P01-xxxxxxxx-19-xx-xx-xx-030</p>	<ol style="list-style-type: none"> 1. Keep pressing "+" or "-" until "0" is displayed. 2. Confirm "0" with "E". The cursor jumps to the next position. ↓ is displayed and is highlighted in black. → See next graphic.
 <p style="text-align: right; font-size: small;">P01-xxxxxxxx-19-xx-xx-xx-031</p>	<p>Use "E" to save the new value and exit the editing mode. → See next graphic.</p>
 <p style="text-align: right; font-size: small;">P01-xxxxxxxx-19-xx-xx-xx-032</p>	<p>The new value for the damping is now 30.0 s.</p> <ul style="list-style-type: none"> - Jump to the next parameter with "E". - You can get back to the editing mode with "+" or "-".

5.3.4 Taking pressure applied at device as value

Example: configuring upper range value – assign 20 mA to the pressure value 400 mbar.

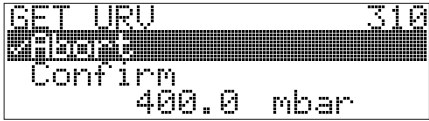
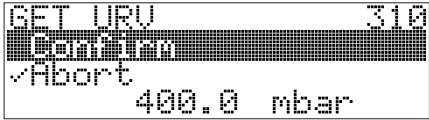
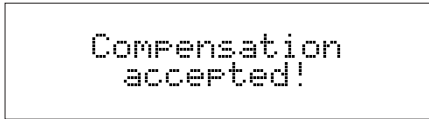
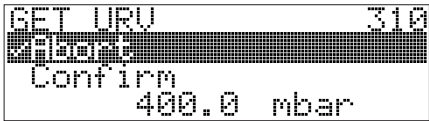
On-site display	Operation
 <p style="text-align: right; font-size: small;">P01-xxxxxxx-19-xx-xx-xx-035</p>	<p>The bottom line on the on-site display displays the pressure present, here 400 mbar.</p>
 <p style="text-align: right; font-size: small;">P01-xxxxxxx-19-xx-xx-xx-036</p>	<p>Use "+" or "-" to switch to the "Confirm" option. The active selection is highlighted in black.</p>
 <p style="text-align: right; font-size: small;">P01-xxxxxxx-19-xx-xx-xx-037</p>	<p>Use "E" to assign the value (400 mbar) to the GET URV parameter. The device confirms the calibration and jumps back to the parameter, here GET URV (see next graphic).</p>
 <p style="text-align: right; font-size: small;">P01-xxxxxxx-19-xx-xx-xx-035</p>	<p>Switch to the next parameter with "E".</p>

5.4 Locking/unlocking operation

Once you have entered all the parameters, you can lock your entries against unauthorised and undesired access.

You have the following possibilities for locking/unlocking the operation:

- Via a DIP-switch on the electronic insert, locally on the display (→ see Page 16, Fig. 7).
- Via the on-site display (optional)
- Via digital communication.

The -symbol on the on-site display indicates that operation is locked. Parameters which refer to how the display appears, e.g. LANGUAGE and DISPLAY CONTRAST can still be altered.

The table provides an overview of the locking functions:

Locking via	View/ read parameter	Modify/write via ¹⁾		Unlocking via		
		On-site display	Remote operation	DIP-Switch	On-site display	Remote operation
DIP-Switch	yes	no	no	yes	no	no
On-site display	yes	no	no	no	yes	yes
Remote operation	yes	no	no	no	yes	yes

- 1) Parameters which refer to how the display appears, e.g. LANGUAGE and DISPLAY CONTRAST can still be altered.

	Locking/Unlocking operation via on-site display or remote operation
Locking operation	<ol style="list-style-type: none"> 1. Select INSERT PIN NO. parameter, Menu path: GROUP SELECTION → OPERATING MENU → OPERATION → INSERT PIN NO. 2. To lock operation, enter a number for this parameter between 0...9999 that is ≠100.
Unlocking operation	<ol style="list-style-type: none"> 1. Select INSERT PIN NO. parameter. 2. To unlock operation, enter "100" for the parameter.

6 Commissioning



Warning!

- If a pressure smaller than the minimum permitted pressure is present at the device, the messages "E120 Sensor low pressure" and "E727 Sensor pressure error - overrange" are output in succession.
- If a pressure greater than the maximum permitted pressure is present at the device, the messages "E115 Sensor overpressure" and "E727 Sensor pressure error - overrange" are output in succession.
- Messages E727, E115 and E120 are "Error"-type messages and can be configured as a "Warning" or an "Alarm". These messages are configured as "Warning" messages at the factory. This setting prevents the current output from assuming the set alarm current value for applications (e.g. cascade measurement) where the user is consciously aware of the fact that the sensor range can be exceeded.
- We recommend setting messages E727, E115 and E120 to "Alarm" in the following instances:
 - The sensor range does not have to be exceeded for the measuring application.
 - Position adjustment has to be carried out that has to correct a large measured error as a result of the orientation of the device (e.g. devices with a diaphragm seal).

6.1 Position adjustment

Due to the orientation of the device, there may be a shift in the measured value, i.e. when the container is empty, the measured value parameter does not display zero. There are three options to choose from when performing position adjustment.

(Menu path: GROUP SELECTION → OPERATING MENU → SETTINGS → POSITION ADJUSTMENT)

Parameter name	Description
POS. ZERO ADJUST (685) Entry	<p>Position adjustment – the pressure difference between zero (set point) and the measured pressure need not be known. (A reference pressure is present at the device.)</p> <p>Example:</p> <ul style="list-style-type: none"> – MEASURED VALUE = 2.2 mbar – Correct the MEASURED VALUE via the POS. ZERO ADJUST parameter with the "Confirm" option. This means that you are assigning the value 0.0 to the pressure present. – MEASURED VALUE (after pos. zero adjust) = 0.0 mbar – The current value is also corrected. <p>The CALIB. OFFSET parameter displays the resulting pressure difference (offset) by which the MEASURED VALUE was corrected.</p> <p>Factory setting: 0</p>
POS. INPUT VALUE (563) Entry	<p>Position adjustment – the pressure difference between zero (set point) and the measured pressure need not be known. (A reference pressure is present at the device.)</p> <p>Example:</p> <ul style="list-style-type: none"> – MEASURED VALUE = 0.5 mbar – For the POS. INPUT VALUE parameter, specify the desired set point for the MEASURED VALUE, e.g. 2 mbar. ($\text{MEASURED VALUE}_{\text{new}} = \text{POS. INPUT VALUE}$) – MEASURED VALUE (after entry for POS. INPUT VALUE) = 2.0 mbar – The CALIB. OFFSET parameter displays the resulting pressure difference (offset) by which the MEASURED VALUE was corrected. $\text{CALIB. OFFSET} = \text{MEASURED VALUE}_{\text{old}} - \text{POS. INPUT VALUE}$, here: $\text{CALIB. OFFSET} = 0.5 \text{ mbar} - 2.0 \text{ mbar} = -1.5 \text{ mbar}$) – The current value is also corrected. <p>Factory setting: 0</p>
CALIB. OFFSET (319) Entry	<p>Position adjustment – the pressure difference between zero (set point) and the measured pressure is known.</p> <p>Example:</p> <ul style="list-style-type: none"> – MEASURED VALUE = 2.2 mbar – Via the CALIB. OFFSET parameter, enter the value by which the MEASURED VALUE should be corrected. To correct the MEASURED VALUE to 0.0 mbar, you must enter the value 2.2 here. ($\text{MEASURED VALUE}_{\text{new}} = \text{MEASURED VALUE}_{\text{old}} - \text{CALIB. OFFSET}$) – MEASURED VALUE (after entry for calib. offset) = 0.0 mbar – The current value is also corrected. <p>Factory setting: 0</p>

6.2 Pressure measurement

6.2.1 Quick Setup menu for Pressure measuring mode – on-site display



Note!

See also Page 18, Section 4.2.3 "Function of the operating elements" and Page 19, 4.3 "On-site operation via on-site display".

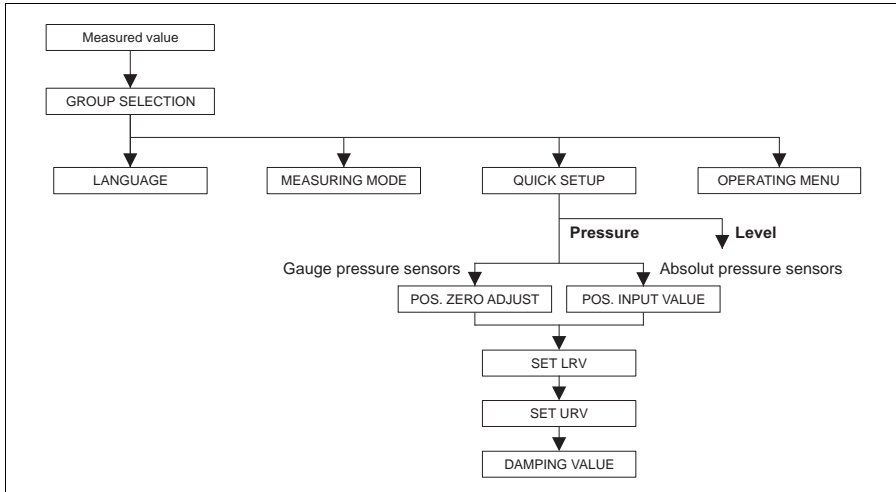

P01-PMx7xxxx-19-xx-xx-xx-046

Fig. 8: Quick Setup menu for Pressure measuring mode

On-site operation
Measured value display On-site display: Switch from the measured value display to GROUP SELECTION with  .
GROUP SELECTION Select MEASURING MODE.
MEASURING MODE Select "Pressure" option.
GROUP SELECTION Select QUICK SETUP menu.
POS. ZERO ADJUST (gauge pressure sensors) Due to orientation of the device, there may be a shift in the measured value. You correct the MEASURED VALUE via the POS. ZERO ADJUST parameter with the "Confirm" option, i. e. you assign the value 0.0 to the pressure present.
POS. INPUT VALUE (absolute pressure sensors) Due to orientation of the device, there may be a shift in the measured value. For the POS. INPUT VALUE parameter, specify the desired set point for the MEASURED VALUE.

On-site operation
SET LRV Set the measuring range (enter 4 mA value). Specify a pressure value for the lower current value (4 mA value). A reference pressure does not have to be present at the device.
SET URV Set the measuring range (enter 20 mA value). The pressure for the upper current value (20 mA value) is present at device. With the "Confirm" option, you assign the upper current value to the pressure value present.
DAMPING TIME Enter damping time (time constant τ). The damping affects the speed at which all subsequent elements, such as the on-site display, measured value and current output react to a change in the pressure.

6.2.2 On-site operation – on-site display not connected

If no on-site display is connected, the following functions are possible by means of the three keys on the electronic insert or on the exterior of the device:

- Position adjustment (zero point correction)
- Setting lower range value and upper range value
- Device reset, → see also Page 17, Section 4.2.2 "Function of the operating elements", Table.



Note!

- The device is configured for the Pressure measuring mode as standard. You can switch measuring modes by means of the MEASURING MODE parameter.
- The operation must be unlocked. → See Page 23, Section 4.4 "Locking /unlocking operation".
- The pressure applied must be within the nominal pressure limits of the sensor. See information on the nameplate.



Warning!

If the measuring mode is changed, the span setting (URV) must be verified in the "Calibration" → "Basic Setup" operating menu and, if necessary, reconfigured.

Carry out position adjustment. ¹⁾		Setting lower range value.		Setting upper range value.	
Pressure is present at device.		Desired pressure for lower range value is present at device.		Desired pressure for upper range value is present at device.	
↓		↓		↓	
Press "E"-key for 3 s.		Press "-"-key for 3 s.		Press "+"-key for 3 s.	
↓		↓		↓	
Does the LED on the electronic insert light up briefly?		Does the LED on the electronic insert light up briefly?		Does the LED on the electronic insert light up briefly?	
Yes	No	Yes	No	Yes	No
↓	↓	↓	↓	↓	↓
Applied pressure for position adjustment has been accepted.	Applied pressure for position adjustment has not been accepted. Observe the input limits.	Applied pressure for lower range value has been accepted.	Applied pressure for lower range value has not been accepted. Observe the input limits.	Applied pressure for upper range value has been accepted.	Applied pressure for upper range value has not been accepted. Observe the input limits.

1) Observe "Warning" on Page 24.

6.3 Level measurement

6.3.1 Quick Setup menu for Level measuring mode – on-site display



Note!

- Some parameters are only displayed if other parameters are appropriately configured (see the following table).
- The following parameters are set to the following values in the factory:
 - LEVEL SELECTION: Level Easy Pressure
 - CALIBRATION MODE: Wet
 - OUTPUT UNIT or LIN. MEASURAND: %
 - EMPTY CALIB.: 0.0
 - FULL CALIB.: 100.0
 - SET LRV (BASIC SETTINGS group): 0.0 (corresponds to 4 mA value)
 - SET URV (BASIC SETTINGS group): 100.0 (corresponds to 20 mA value).
- → For parameter description see CD-ROM, Operating Instructions BA00274P.
- The quick setup is suitable for simple and quick commissioning. If you wish to make more complex settings, e.g. change the unit from "%" to "m", you will have to calibrate using the BASIC SETTINGS group.
- See also Page 18, Section 4.2.3 "Function of the operating elements" and Page 19, 4.3 "On-site operation via on-site display".



Warning!

If the measuring mode is changed, the span setting (URV) must be verified in the "Calibration" → "Basic Setup" operating menu and, if necessary, reconfigured.

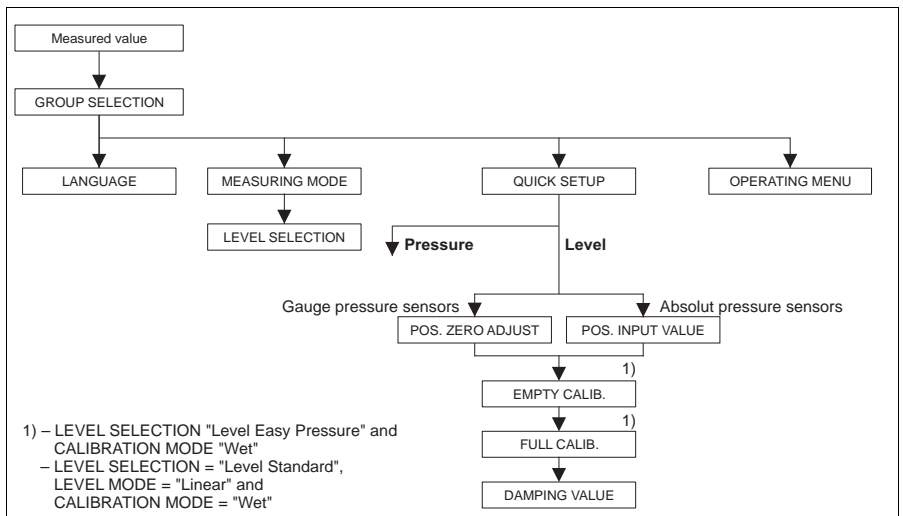



Fig. 9: Quick Setup menu for the Level measuring mode

P01-PMx7xxxx-19-xx-xx-xx-047

On-site operation
Measured value display On-site display: Switch from the measured value display to GROUP SELECTION with  .
GROUP SELECTION Select MEASURING MODE.
MEASURING MODE Select "Level" option.
LEVEL SELECTION Select level mode.
GROUP SELECTION Select QUICK SETUP menu.
POS. ZERO ADJUST (gauge pressure sensors) Due to orientation of the device, there may be a shift in the measured value. You correct the MEASURED VALUE via the POS. ZERO ADJUST parameter with the "Confirm" option, i. e. you assign the value 0.0 to the pressure present.
POS. INPUT VALUE (absolute pressure sensors) Due to orientation of the device, there may be a shift in the measured value. For the POS. INPUT VALUE parameter, specify the desired set point for the MEASURED VALUE.
EMPTY CALIB. ¹⁾ Enter level for the lower calibration point. For this parameter, enter a level value which is assigned to the pressure present at the device.
FULL CALIB. ¹⁾ Enter level for the upper calibration point. For this parameter, enter a level value which is assigned to the pressure present at the device.
DAMPING TIME Enter damping time (time constant τ). The damping affects the speed at which all subsequent elements, such as the on-site display, measured value and current output react to a change in the pressure.

- 1) – LEVEL SELECTION "Level Easy Pressure" and CALIBRATION MODE "Wet"
 – LEVEL SELECTION "Level Standard", LEVEL MODE "Linear" and CALIBRATION MODE "Wet"
 (Menu path for CALIBRATION MODE: GROUP SELECTION → OPERATING MENU → SETTINGS → BASIC SETTINGS)

6.3.2 On-site operation – on-site display not connected

If no on-site display is connected, the following functions are possible by means of the three keys on the electronic insert or on the exterior of the device:

- Position adjustment (zero point correction)
- Set the lower and upper pressure value and assign to the lower and upper level value
- Device reset, → see also Page 17, section 4.2.2 "Function of the operating elements", Table.



Note!

- The device is configured for the Pressure measuring mode as standard. You can switch measuring modes by means of the MEASURING MODE parameter.
- The following parameters are set to the following values in the factory:
 - LEVEL SELECTION: Level Easy Pressure
 - CALIBRATION MODE: Wet
 - OUTPUT UNIT or LIN. MEASURAND: %
 - EMPTY CALIB.: 0.0
 - FULL CALIB.: 100.0.
 - SET LRV: 0.0 (corresponds to 4 mA value)
 - SET URV: 100.0 (corresponds to 20 mA value)

These parameters can only be modified by means of the on-site display or remote operation such as FieldCare.

- The "-" and "+" keys only have a function in the following cases:
 - LEVEL SELECTION "Level Easy Pressure", CALIBRATION MODE "Wet"
 - LEVEL SELECTION "Level Standard", LEVEL MODE "Linear", CALIBRATION MODE "Wet"

The keys have no function in other settings.

- The operation must be unlocked. → See Page 23, Section 4.4 "Locking /unlocking operation".
- The pressure applied must be within the nominal pressure limits of the sensor. See information on the nameplate.
- LEVEL SELECTION, CALIBRATION MODE, LEVEL MODE, EMPTY CALIB., FULL CALIB, SET LRV and SET URV are parameter names used for on-site display or remote operation such as FieldCare, for instance.
- → For parameter description see CD-ROM, Operating Instructions BA00274P.



Warning!

If the measuring mode is changed, the span setting (URV) must be verified in the "Calibration" → "Basic Setup" operating menu and, if necessary, reconfigured.

Carry out position adjustment.¹⁾		Setting lower pressure value.		Setting upper pressure value.	
Pressure is present at device.		Desired pressure for lower pressure value (EMPTY PRESSURE) is present at device.		Desired pressure for upper pressure value (FULL PRESSURE) is present at device.	
↓		↓		↓	
Press "E"-key for 3 s.		Press "-"-key for 3 s.		Press "+"-key for 3 s.	
↓		↓		↓	
Does the LED on the electronic insert light up briefly?		Does the LED on the electronic insert light up briefly?		Does the LED on the electronic insert light up briefly?	
Yes	No	Yes	No	Yes	No
↓	↓	↓	↓	↓	↓
Applied pressure for position adjustment has been accepted.	Applied pressure for position adjustment has not been accepted. Observe the input limits.	The pressure present was saved as the lower pressure value (EMPTY PRESSURE) and assigned to the lower level value (EMPTY CALIB.).	The pressure present was not saved as the lower pressure value. Observe the input limits.	The pressure present was saved as the upper pressure value (FULL PRESSURE) and assigned to the upper level value (FULL CALIB.).	The pressure present was not saved as the upper pressure value. Observe the input limits.

1) Observe "Warning" on Page 24.

www.endress.com/worldwide

Endress+Hauser 
People for Process Automation

KA01019P/00/EN/16.14
71270342
CCS/FM+SGML 9

