

# Technical Information

## Deltapilot S FMB70

Hydrostatic level measurement



Pressure sensor with CONTITE™ measuring cell.  
Condensate-resistant

### Application

The device is used for the following measuring tasks:

- Hydrostatic pressure measurement in liquids and paste-like media in all areas of process engineering, process measuring technology, pharmaceuticals and the food industry
- Level, volume or mass measurements in liquids

### Your benefits

- Very good reproducibility and long-term stability
- Maximum plant safety provided by one-of-a-kind, condensate-proofed CONTITE measuring cell
- High reference accuracy down to 0.075%
- Used for process pressure monitoring up to SIL 3, certified according to IEC 61508 by TÜV SÜD
- High level of safety during operation thanks to function monitoring from the measuring cell to the electronics
- Simple electronics exchange guaranteed with HistoROM®/M-DAT
- Standardized platform for differential pressure, hydrostatics, and pressure (Deltabar S – Deltapilot S – Cerabar S)
- Simple, fast commissioning through a practice-oriented user interface
- Extensive diagnostic functions
- Use in drinking water: NSF

## Table of contents

<b>Document information</b> .....	<b>4</b>	"Separate housing" version .....	26
Symbols used .....	4	Turning the housing .....	27
Terms and abbreviations .....	6	Silicone-free applications .....	27
		Applications with hydrogen .....	27
<b>Function and system design</b> .....	<b>7</b>	<b>Environment</b> .....	<b>28</b>
Device selection .....	7	Ambient temperature range .....	28
Measuring principle .....	8	Storage temperature range .....	28
Level measurement in closed tanks with pressure overlay ...	9	Degree of protection .....	28
Density measurement .....	9	Climate class .....	28
Communication protocol .....	10	Vibration resistance .....	28
		Electromagnetic compatibility .....	28
<b>Input</b> .....	<b>10</b>	<b>Process</b> .....	<b>29</b>
Measured variable .....	10	Process temperature limits .....	29
Measuring range .....	10	Pressure specifications .....	29
		<b>Mechanical construction</b> .....	<b>30</b>
<b>Output</b> .....	<b>11</b>	Device height .....	30
Output signal .....	11	T14 housing, optional display on the side .....	30
Signal range – 4 to 20 mA HART .....	11	T15 housing, optional display on the top .....	31
Signal on alarm .....	11	T17 housing (hygienic), optional display on the side .....	31
Load – 4 to 20 mA HART .....	11	Process connections .....	32
Dead time, time constant .....	12	Separate housing:	
Dynamic behavior: current output .....	12	wall and pipe mounting with mounting bracket .....	40
Dynamic behavior: digital output (HART electronics) .....	12	Materials not in contact with process .....	41
Dynamic behavior: PROFIBUS PA .....	12	Materials in contact with process .....	44
Dynamic behavior: FOUNDATION Fieldbus .....	13	<b>Operability</b> .....	<b>45</b>
Damping .....	13	Operating concept .....	45
Alarm current .....	13	Local operation .....	45
Firmware version .....	13	Remote operation .....	47
Protocol-specific data .....	14	System integration .....	49
		<b>Certificates and approvals</b> .....	<b>50</b>
<b>Power supply</b> .....	<b>18</b>	CE mark .....	50
Terminal assignment .....	18	Ex approvals .....	50
Supply voltage .....	19	Suitability for hygienic processes .....	50
Current consumption .....	19	Functional safety SIL/ IEC 61508 Declaration of Conformity (optional) .....	50
Electrical connection .....	20	Overfill protection .....	50
Terminals .....	20	CRN approvals .....	50
Cable entry .....	20	Standards and guidelines .....	51
Device plug connectors .....	20	Pressure Equipment Directive (PED) .....	51
Cable specification .....	22	Marine approval .....	51
Residual ripple .....	22	Drinking water approval .....	51
Overtoltage protection (optional) .....	22	Classification of process sealing between electrical systems and (flammable or combustible) process fluids in accordance with ANSI/ISA 12.27.01 .....	51
Influence of power supply .....	22	Inspection certificate .....	51
		Calibration .....	52
<b>Performance characteristics</b> .....	<b>23</b>	Certificate of Compliance ASME BPE .....	52
Reference operating conditions .....	23	<b>Ordering information</b> .....	<b>53</b>
Long-term stability .....	23	Configuration data sheet .....	53
Influence of the installation position .....	23		
Resolution .....	23		
Reference accuracy .....	23		
Total performance .....	23		
Total error .....	24		
Warm-up period .....	24		
Thermal change of the zero output and the output span ...	24		
<b>Installation</b> .....	<b>25</b>		
General installation instructions .....	25		
Wall and pipe-mounting .....	25		





---

<b>Accessories</b> .....	<b>55</b>
HistoROM®/M-DAT .....	55
Wall and pipe-mounting .....	55
Welding flanges .....	55
Weld-in adapter for universal process adapter .....	55
Weld-in adapter for ISO G ½ thread .....	55
Adapter Uni .....	56
<b>Additional documentation</b> .....	<b>57</b>
Field of Activities .....	57
Technical Information .....	57
Operating Instructions .....	57
Brief Operating Instructions .....	57
Functional safety manual (SIL) .....	57
Safety Instructions .....	57
Installation/ Control Drawings .....	58
Overfill protection .....	58
<b>Registered trademarks</b> .....	<b>59</b>
HART® .....	59
PROFIBUS® .....	59
FOUNDATION™ Fieldbus .....	59







## Document information

### Symbols used





#### Warning symbols

Symbol	Meaning
 <small>A0011189-EN</small>	<b>DANGER!</b> This symbol alerts you to a dangerous situation. Failure to avoid this situation will result in serious or fatal injury.
 <small>A0011190-EN</small>	<b>WARNING!</b> This symbol alerts you to a dangerous situation. Failure to avoid this situation can result in serious or fatal injury.
 <small>A0011191-EN</small>	<b>CAUTION!</b> This symbol alerts you to a dangerous situation. Failure to avoid this situation can result in minor or moderate injury.
 <small>A0011192-EN</small>	<b>NOTE!</b> This symbol contains information on procedures and other facts which do not result in personal injury.









#### Electrical symbols

Symbol	Meaning
 <small>A0018335</small>	<b>Direct current</b> A terminal to which DC voltage is applied or through which direct current flows.
 <small>A0018336</small>	<b>Alternating current</b> A terminal to which alternating voltage is applied or through which alternating current flows.
 <small>A0018337</small>	<b>Direct current and alternating current</b> <ul style="list-style-type: none"> <li>▪ A terminal to which alternating voltage or DC voltage is applied.</li> <li>▪ A terminal through which alternating current or direct current flows.</li> </ul>
 <small>A0018338</small>	<b>Ground connection</b> A grounded terminal which, as far as the operator is concerned, is grounded via a grounding system.
 <small>A0018339</small>	<b>Protective ground connection</b> A terminal that must be connected to ground prior to establishing any other connections.
 <small>A0011201</small>	<b>Equipotential connection</b> A connection that must be connected to the plant grounding system: This may be a potential equalization line or a star grounding system depending on national or company codes of practice.



#### Tool symbols

Symbol	Meaning
 <small>A0011219</small>	Phillips head screwdriver
 <small>A0011220</small>	Flat blade screwdriver
 <small>A0013442</small>	Torx screwdriver
 <small>A0011222</small>	Hexagon wrench
 <small>A0011221</small>	Allen key

### Symbols for certain types of information

Symbol	Meaning
 A0011182	<b>Allowed</b> Indicates procedures, processes or actions that are allowed.
 A0011183	<b>Preferred</b> Indicates procedures, processes or actions that are preferred.
 A0011184	<b>Forbidden</b> Indicates procedures, processes or actions that are forbidden.
 A0011193	<b>Tip</b> Indicates additional information.
 A0015483	<b>Reference to documentation</b> Refers to the corresponding device documentation.
 A0015484	<b>Reference to page</b> Refers to the corresponding page number.
 A0015486	<b>Reference to diagrams</b> Refers to the corresponding graphic number and page number.
1., 2., ...	Series of steps
 A0015488	<b>Help in the event of a problem</b>

### Symbols in graphics

Symbol	Meaning
1, 2, 3, 4, ...	Numbering for main positions
1., 2., ...	Series of steps
A, B, C, D, ...	Views
A-A, B-B, ...	Sections
 A0011187	<b>Hazardous area</b> Indicates a hazardous area.
 A0011188	Safe area (non-hazardous area) Indicates a non-hazardous area.

Terms and abbreviations

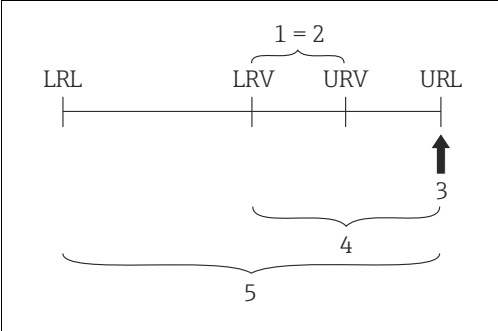
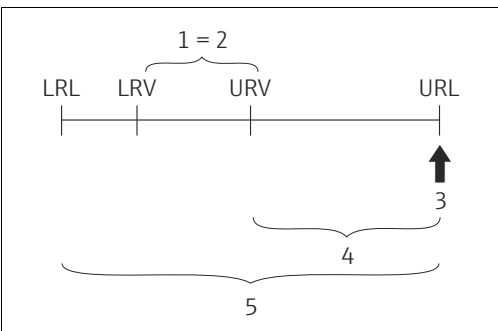
Term/abbreviation	Explanation
MWP	The MWP (maximum working pressure) for the individual sensors depends on the lowest-rated element, with regard to pressure, of the selected components, i.e. the process connection has to be taken into consideration in addition to the measuring cell. Also observe pressure-temperature dependency. For the relevant standards and additional notes, see the "→ 29" section.
OPL	The OPL (over pressure limit = sensor overload limit) for the sensor depends on the lowest-rated element, with regard to pressure, of the selected components, i.e. the process connection must be taken into consideration in addition to the measuring cell. Also observe pressure-temperature dependency. For the relevant standards and additional notes, see the "→ 29" section.
LRL	Lower range limit
URL	Upper range limit
LRV	Lower range value
URV	Upper range value
<b>TD</b>	<b>Turn down</b>
<p>Case 1:</p> <ul style="list-style-type: none"> <li>▪ <math>  \text{Lower range value (LRV)}   \leq   \text{Upper range value (URV)}  </math></li> </ul> <p>Example:</p> <ul style="list-style-type: none"> <li>▪ Lower range value (LRV) = 0 mbar</li> <li>▪ Upper range value (URV) = 40 mbar (0.6 psi)</li> <li>▪ Nominal value (URL) = 400 mbar (6 psi)</li> </ul> <p>Turn down:</p> <ul style="list-style-type: none"> <li>▪ <math>\text{TD} = \text{URL} /   \text{URV}   = 10:1</math></li> </ul> <p>Set span:</p> <ul style="list-style-type: none"> <li>▪ <math>\text{URV} - \text{LRV} = 40 \text{ mbar (0.6 psi)}</math></li> <li>▪ This span is based on the zero point.</li> </ul>	 <p style="text-align: right; font-size: small;">A0019783</p> <p>Example: 400 mbar (6 psi) measuring cell</p>
<p>Case 2:</p> <ul style="list-style-type: none"> <li>▪ <math>  \text{Lower range value (LRV)}   \geq   \text{Upper range value (URV)}  </math></li> </ul> <p>Example:</p> <ul style="list-style-type: none"> <li>▪ Lower range value (LRV) = -200 mbar (-3 psi)</li> <li>▪ Upper range value (URV) = 0 bar</li> <li>▪ Nominal value (URL) = 400 mbar (6 psi)</li> </ul> <p>Turn down:</p> <ul style="list-style-type: none"> <li>▪ <math>\text{TD} = \text{URL} /   \text{LRV}   = 2:1</math></li> </ul> <p>Set span:</p> <ul style="list-style-type: none"> <li>▪ <math>\text{URV} - \text{LRV} = 200 \text{ mbar (3 psi)}</math></li> <li>▪ This span is based on the zero point.</li> </ul>	 <p style="text-align: right; font-size: small;">A0016451</p> <p>Example: 400 mbar (6 psi) measuring cell</p> <ol style="list-style-type: none"> <li>1 Set span</li> <li>2 Zero-based span</li> <li>3 Nominal value<sup>≅</sup> Upper range limit (URL)</li> <li>4 Nominal measuring range</li> <li>5 Sensor measuring range</li> </ol>

## Function and system design

### Device selection

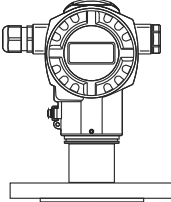
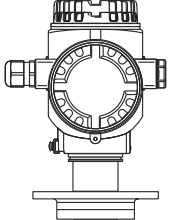
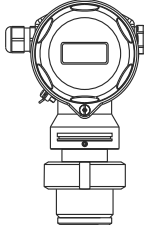
Deltapilot S	FMB70
	<div style="display: flex; justify-content: space-around; align-items: center;"> <div style="text-align: center;"> <p>T14</p>  </div> <div style="text-align: center;"> <p>T15</p>  </div> <div style="text-align: center;"> <p>T17</p>  </div> </div> <p style="text-align: right; font-size: small;">A0019982</p>
Field of application	<ul style="list-style-type: none"> <li>▪ Level measurement</li> <li>▪ Pressure measurement</li> </ul>
Industries	Food, pharmaceutical, environment (fresh water and wastewater), chemical
Process connections	<ul style="list-style-type: none"> <li>▪ Thread</li> <li>▪ Flange</li> <li>▪ Flush-mounted hygienic connections</li> </ul>
Process connection material	<ul style="list-style-type: none"> <li>▪ AISI 316L (1.4435 or 1.4404) - see "Materials" section)</li> <li>▪ Alloy C276 (2.4819)</li> </ul>
Measuring ranges	from -100 to +100 mbar (-1.5 to +1.5 psi) to -1000 to +10000 mbar (-15 to +150 psi)
OPL	Max. 40 bar (600 psi)
Process temperature range	-10 to +100 °C (+14 to 212 °F); +135 °C (275 °F) for a maximum of 30 minutes
Ambient temperature range	<ul style="list-style-type: none"> <li>▪ -40 to +85 °C (-40 to 185 °F)</li> <li>▪ Separate housing: -20 to +60 °C (-4 to 140 °F)</li> </ul>
Reference accuracy	±0.1% of the set span
Supply voltage	<ul style="list-style-type: none"> <li>▪ Version for non-hazardous area: <ul style="list-style-type: none"> <li>▪ 4 to 20 mA HART: 10.5 to 45 V DC</li> <li>▪ PROFIBUS PA and FOUNDATION Fieldbus: 9 to 32 V DC</li> </ul> </li> <li>▪ Ex ia: 10.5 to 30 V DC</li> </ul>
Output	<ul style="list-style-type: none"> <li>▪ 4 to 20 mA with superimposed HART protocol</li> <li>▪ PROFIBUS PA or</li> <li>▪ FOUNDATION Fieldbus</li> </ul>
Options	<ul style="list-style-type: none"> <li>▪ Gold-rhodium coated process isolating diaphragm</li> <li>▪ 3.1 inspection certificate</li> <li>▪ 3A and EHEDG approval</li> <li>▪ HistoROM®/M-DAT memory module</li> <li>▪ Separate housing</li> </ul>
Specialties	<ul style="list-style-type: none"> <li>▪ Absolutely resistant to condensate thanks to hermetically sealed CONTITE™ cell</li> <li>▪ Maximum flexibility thanks to modular design</li> <li>▪ Special cleaning of the transmitter to remove paint-wetting substances, for use in paint shops</li> </ul>

## Measuring principle

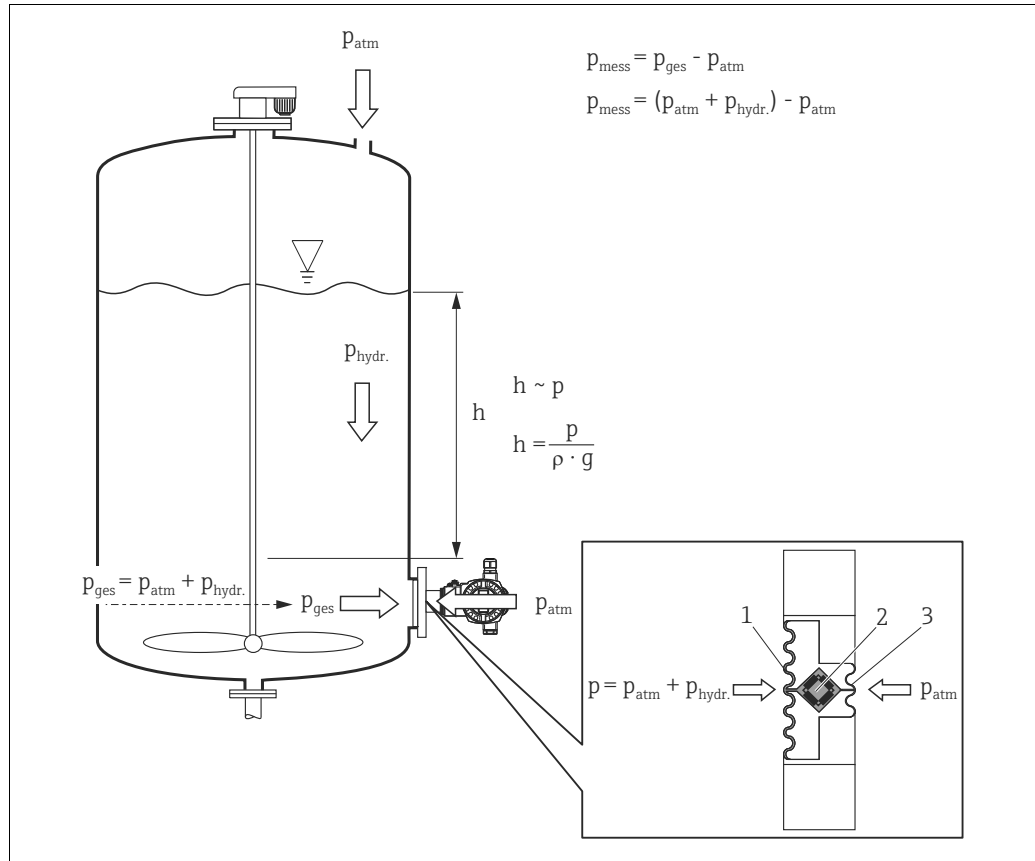

## Deltapilot S hydrostatic level measurement and measuring principle

- 1 Process isolating diaphragm
  - 2 Sensing element
  - 3 Rear isolating membrane of the CONTITE™ measuring cell
- $g$  Gravitational acceleration
  - $h$  Level height
  - $p_{\text{tot}}$  Total pressure = hydrostatic pressure + atmospheric pressure
  - $p_{\text{atm}}$  Atmospheric pressure
  - $p_{\text{hydr.}}$  Hydrostatic pressure
  - $p_{\text{meas}}$  Measured pressure in the measuring cell = hydrostatic pressure
  - $\rho$  Density of the medium

Due to its weight, a liquid column creates hydrostatic pressure. If the density is constant, the hydrostatic pressure depends solely on the height  $h$  of the liquid column.

The CONTITE™ measuring cell, which works according to the principle of the gauge pressure sensor, constitutes the core of the Deltapilot S. In contrast to conventional gauge pressure sensors, the precision measuring element (2) in the CONTITE™ measuring cell is absolutely protected between the process isolating diaphragm (1) and the rear isolating membrane (3). Thanks to this hermetic sealing of the measuring element, the CONTITE™ measuring cell is absolutely insensitive to condensate/condensation and aggressive gases. The pressure applied is transferred from the process isolating diaphragm to the measuring element by means of an oil without any loss in pressure.

The sensor temperature is measured by means of the resistance bridge in the measuring cell. The electronics can compensate any measuring errors resulting from fluctuations in temperature with these measured temperature values.

A linearization with max. 32 points, based on a table entered either manually or semi-automatically, can be activated locally or remotely. This function allows, for example, measurement in engineering units and provides a linear output signal for spherical and horizontal cylindrical tanks, and vessels with a conical outlet.

### Level measurement in closed tanks with pressure overlay

You can determine the differential pressure in tanks with pressure overlay using two Deltapilot S devices. The measured pressure values of the two Deltapilot S devices are sent to a signal processing unit such as Endress+Hauser RMA or a PLC. The signal processing unit or PLC determines the difference in pressure and uses this to calculate the level and the density where necessary.

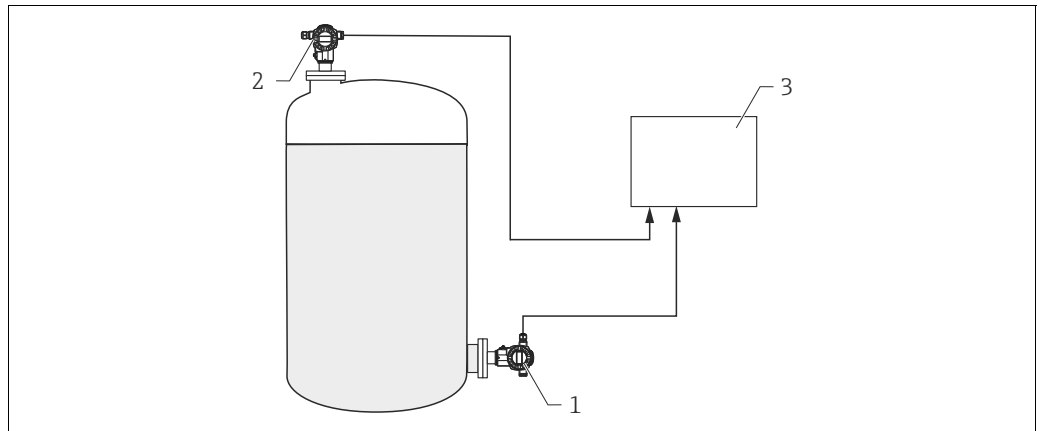

Level measurement in a closed tank with pressure overlay

- 1 Deltapilot 1 measures the total pressure (hydrostatic pressure and top pressure)
- 2 Deltapilot 2 measures the top pressure
- 3 The signal processing unit determines the difference in pressure and uses this to calculate the level

#### HINWEIS

##### Measured errors may occur.

If the ratio of level to top pressure is  $>1:6$ , significant measured errors may occur. Reproducibility is not affected.

- ▶ When selecting the Deltapilot S, make sure you choose sufficiently large measuring ranges (→ see example).

Example:

- Max. hydrostatic pressure = 600 mbar (9 psi)
- Max. top pressure (Deltapilot 2) = 300 mbar (4.5 psi)
- Max. total pressure, measured with Deltapilot 1 = 300 mbar (4.5 psi) + 600 mbar (9 psi) = 900 mbar (13.5 psi) ⇒ measuring cell to be selected: 0 to 1200 mbar (0 to 18 psi)
- Max. pressure, measured with Deltapilot 2: 300 mbar (4.5 psi) ⇒ measuring cell to be selected: 0 to 400 mbar (6 psi)

#### HINWEIS

##### Possibility of probe 2 being flooded during differential pressure measurement.

Measured errors may occur.

- ▶ When installing, make sure probe 2 cannot be flooded.

### Density measurement

You can measure the density in tanks with pressure overlay using two Deltapilot S devices and a signal processing unit or a PLC. The signal processing unit or the PLC calculates the density from the known distance  $\Delta h$  between the two Deltapilot S devices and the two measured values  $p_1$  and  $p_2$ .

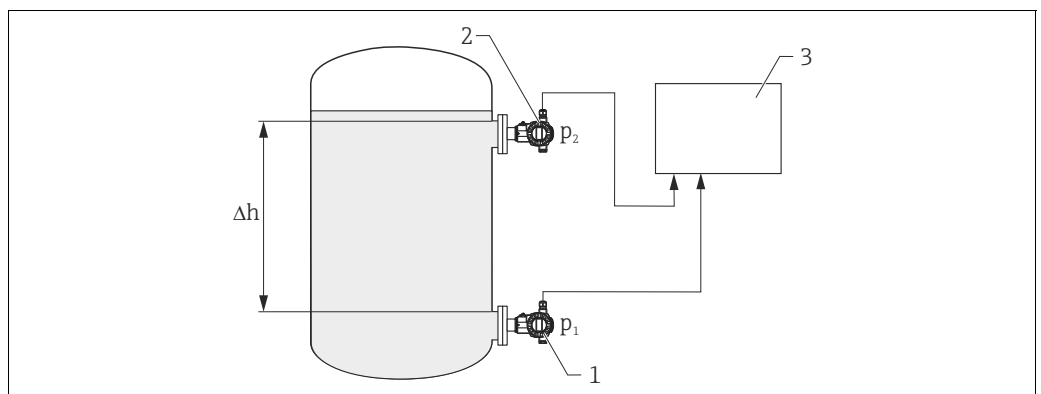

Level measurement in a closed tank with pressure overlay

- 1 Deltapilot 1 determines pressure measured value  $p_1$   
 2 Deltapilot 2 determines pressure measured value  $p_2$   
 3 Signal processing unit determines the density from the two measured values  $p_1$  and  $p_2$  and the distance  $\Delta h$ .

### Communication protocol

- 4 to 20 mA with HART communication protocol
  - PROFIBUS PA
    - The Endress+Hauser devices meet the requirements of the FISCO model.
    - Due to the low current consumption of  $13 \text{ mA} \pm 1 \text{ mA}$ , the following number of devices can be operated on one bus segment if installing as per FISCO:
      - up to 7 Deltapilot S for Ex ia, CSA IS and FM IS applications
      - up to 27 Deltapilot S for all other applications, e.g. in non-hazardous areas, Ex nA, etc.
- Further information on PROFIBUS PA can be found in the Operating Instructions BA00034S "PROFIBUS DP/PA: Guidelines for planning and commissioning" and in the PNO Guideline.
- FOUNDATION Fieldbus
    - The Endress+Hauser devices meet the requirements of the FISCO model.
    - Due to the low current consumption of  $15.5 \text{ mA} \pm 1 \text{ mA}$ , the following number of devices can be operated on one bus segment if installing as per FISCO:
      - up to 6 Deltapilot S for Ex ia, CSA IS and FM IS applications
      - up to 24 Deltapilot S for all other applications, e.g. in non-hazardous areas, Ex nA, etc.
- Further information on FOUNDATION Fieldbus, such as requirements for bus system components can be found in Operating Instructions BA00013S "FOUNDATION Fieldbus Overview".

## Input

Measured variable                      Hydrostatic pressure

### Measuring range

Nominal value	Range limit		Smallest calibratable span	MWP	OPL	Vacuum resistance <sup>1)</sup> Synthetic oil/ Inert oil [bar <sub>abs</sub> (psi <sub>abs</sub> )]	Option <sup>2)</sup>
	lower (LRL) <sup>3)</sup> [bar (psi)]	upper (URL) [bar (psi)]					
100 mbar (1.5 psi)	-0.1 (-1.5)	+0.1 (+1.5)	0.025 (0.375)	2.7 (40.5)	4 (60)	0.01/0.04 (0.15/1)	1C
400 mbar (6 psi)	-0.4 (-6)	+0.4 (+6)	0.04 (0.6)	5.3 (79.5)	8 (120)		1F
1.2 bar (18 psi)	-1.0 (-15)	+1.2 (+18)	0.1 (1.5)	16 (240)	24 (360)		1H
4 bar (60 psi)	-1.0 (-15)	+4 (+60)	0.1 (1.5)	16 (240)	24 (360)		1M
10 bar (150 psi)	-1.0 (-15)	+10 (+150)	0.1 (1.5)	27 (405)	40 (600)		1P

- 1) The vacuum resistance applies for the measuring cell under reference operating conditions.  
 2) Product Configurator, "Sensor range; Sensor overload range" ordering feature  
 3) By default, the device is set to a lower sensor limit of 0 bar. Please specify in the order if the lower sensor limit is to be set to a different default value.

## Output

### Output signal

- 4 to 20 mA with superimposed digital communication protocol HART, 2-wire
- Digital communication signal PROFIBUS PA (Profile 3.0)
  - Signal coding: Manchester Bus Powered (MBP): Manchester II
  - Transmission rate: 31.25 KBit/s voltage mode
- Digital communication signal FOUNDATION Fieldbus
  - Signal coding: Manchester Bus Powered (MBP): Manchester II
  - Transmission rate: 31.25 KBit/s voltage mode

Output	Operation (→ 45 ff)		
	External + LCD	Internal + LCD	Internal
	Option <sup>1)</sup>		
4 to 20mA HART	A	B	C
4 to 20mA HART, Li=0	D	E	F
PROFIBUS PA	M	N	O
FOUNDATION Fieldbus	P	Q	R

1) Product Configurator "Output; Operation" ordering feature

### Signal range – 4 to 20 mA HART

3.8 mA to 20.5 mA

### Signal on alarm

As per NAMUR NE 43

- 4 to 20 mA HART
  - Options:
    - Max. alarm: can be set from 21 to 23 mA (factory setting: 22 mA)
    - Hold measured value: last measured value is held
    - Min. alarm: 3.6 mA
- PROFIBUS PA: can be configured in Analog Input block,
  - Options: Last Valid Out Value (factory setting), Fail Safe Value, Status bad
- FOUNDATION Fieldbus: can be configured in Analog Input block,
  - Options: Last Good Value, Fail Safe Value (factory setting), Wrong Value

### Load – 4 to 20 mA HART

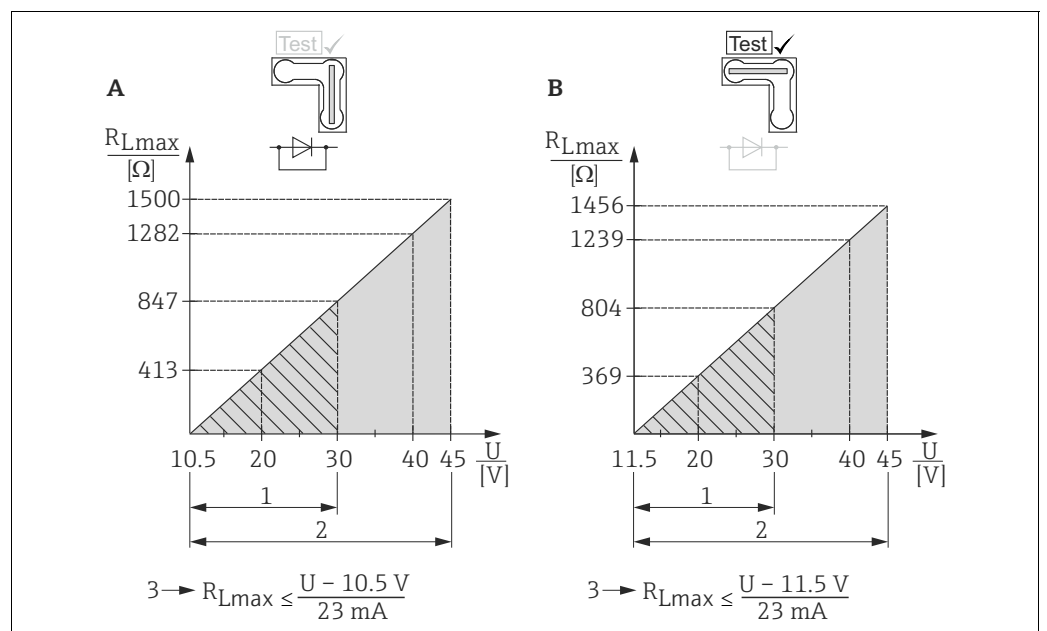

Load diagram, observe the position of the jumper and the explosion protection (→ 19, "Measuring a 4 to 20 mA test signal" section.)

A Jumper for 4 to 20 mA test signal set to "Non-test" position

- B Jumper for 4 to 20 mA test signal set to "Test" position
- 1 Power supply 10.5 (11.5) to 30 V DC for 1/2 G, 1 GD, 1/2 GD, FM IS, CSA IS, NEPSI Ex ia and IEC Ex ia
- 2 Power supply 10.5 (11.5) to 45 V DC for devices for non-hazardous areas, 1/2 D, 1/3 D, 3 G Ex nA, FM DIP, FM NI, CSA dust ignition proof
- 3  $R_{Lmax}$  = maximum load resistance
- U Supply voltage



When operating via a handheld terminal or via a PC with an operating program, a minimum communication resistance of 250 Ω must exist within the loop.

**Dead time, time constant**

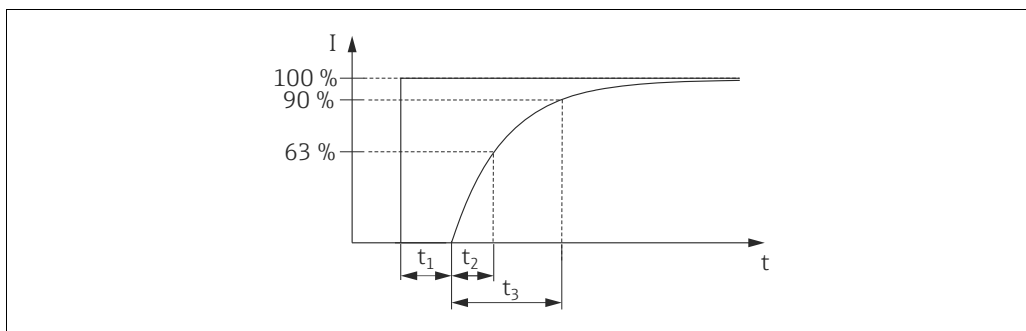

Presentation of the dead time and the time constant

**Dynamic behavior: current output**

	Dead time (t <sub>1</sub> ) [ms]	Time constant T63 (=t <sub>2</sub> ) [ms]	Time constant T90 (=t <sub>3</sub> ) [ms]
Max.	40	30	69

**Dynamic behavior: digital output (HART electronics)**

A typical burst rate of 300 ms results in the following behavior:

	Dead time (t <sub>1</sub> ) [ms]	Dead time (t <sub>1</sub> ) [ms] + Time constant T63 (=t <sub>2</sub> ) [ms]	Dead time (t <sub>1</sub> ) [ms] + Time constant T90 (=t <sub>3</sub> ) [ms]
Min.	200	230	230
Max.	1000	1030	1030

**Reading cycle**

- Acyclic: max. 3/s, typically 1/s (depending on command # and number of preambles)
- Cyclic (burst): max. 3/s, typically 2/s

The device commands the BURST MODE function for cyclic value transmission via the HART communication protocol.

**Cycle time (update time)**

Cyclic (burst): min. 300 ms.

**Response time**

- Acyclic: min. 330 ms, typically 590 ms (depending on command # and number of preambles)
- Cyclic (burst): min. 160 ms, typically 350 ms (depending on command # and number of preambles)

**Dynamic behavior: PROFIBUS PA**

A typical PLC cycle time of 1 s results in the following behavior:

	Dead time (t <sub>1</sub> ) [ms]	Dead time (t <sub>1</sub> ) [ms] + Time constant T63 (=t <sub>2</sub> ) [ms]	Dead time (t <sub>1</sub> ) [ms] + Time constant T90 (=t <sub>3</sub> ) [ms]
Min.	75	105	105
Max.	1275	1305	1305

**Reading cycle (PLC)**

- Cyclic: typically 30/s (depending on the number and type of the function blocks used in the closed-control loop)
- Acyclic: typically 25/s

**Cycle time (update time)**

Min. 200 ms

The cycle time in a bus segment in cyclic data communication depends on the number of devices, on the segment coupler used and on the internal PLC cycle time. A new measured value can be determined up to 5 times a second.

**Response time**

- Cyclic: approx. 10 to 13 ms (depending on the min. slave interval)
- Acyclic: approx. 60 ms to 70 ms (depending on the min. slave interval)

**Dynamic behavior: FOUNDATION Fieldbus**

A typical configuration for the macro cycle time (host system) of 1 s results in the following behavior:

	Dead time (t <sub>1</sub> ) [ms]	Dead time (t1) [ms] + Time constant T63 (=t <sub>2</sub> ) [ms]	Dead time (t1) [ms] + Time constant T90 (=t <sub>3</sub> ) [ms]
Min.	85	115	115
Max.	1085	1115	1115

**Reading cycle**

- Cyclic: max. 10/s (depending on the number and type of function blocks used in the closed-control loop)
- Acyclic: typically 10/s

**Cycle time (update time)**

Cyclic: min. 100 ms

**Response time**

- Cyclic: max. 20 ms (for standard bus parameter settings)
- Acyclic: typically 100 ms (for standard bus parameter settings)

**Damping**

A damping affects all outputs (output signal, display).

- Via onsite display, handheld terminal or PC with operating program, continuous from 0 to 999 s
- Additionally for HART and PROFIBUS PA: via DIP switch on the electronic insert, switch position "on" = set value and "off"
- Factory setting: 2 s

**Alarm current**

Designation	Option <sup>1)</sup>
Min alarm current	J
HART burst mode PV	
Min alarm current + HART burst mode PV	

1) Product Configurator, "Additional options 1" and "Additional options 2" ordering feature

**Firmware version**

Designation	Option <sup>1)</sup>
02.20.zz, HART, DevRev22	72
02.11.zz, HART, DevRev21	73
04.00.zz, FF, DevRev07	74
04.01.zz, PROFIBUS PA, DevRev03	75

Designation	Option <sup>1)</sup>
02.10.zz, HART, DevRev21	76
03.00.zz, FF, DevRev06	77
04.00.zz, PROFIBUS PA	78

1) Product Configurator, "Firmware version" ordering feature

## Protocol-specific data

### HART

Manufacturer ID	17 (11 hex)
Device type ID	26 (1A hex)
Device revision	<ul style="list-style-type: none"> <li>▪ 21 (15 hex) - SW version 02.1y.zz - HART specification 5</li> <li>▪ 22 (16 hex) - SW version 02.2y.zz - HART specification 7</li> </ul>
HART specification	<ul style="list-style-type: none"> <li>▪ 5</li> <li>▪ 7</li> </ul>
DD revision	<ul style="list-style-type: none"> <li>▪ 4 (russian in language selection) for device revision 21</li> <li>▪ 3 (netherlands in language selection) for device revision 21</li> <li>▪ 1 for device revision 22</li> </ul>
Device description files (DTM, DD)	Information and files at: <ul style="list-style-type: none"> <li>▪ www.endress.com</li> <li>▪ www.hartcomm.org</li> </ul>
HART load	Min. 250 Ω
HART device variables	The measured values are assigned to the device variables as follows: <p><b>Measured values for PV (primary variable)</b></p> <ul style="list-style-type: none"> <li>▪ Pressure</li> <li>▪ Level</li> <li>▪ Tank content</li> </ul> <p><b>Measured values for SV, TV (second and third variable)</b></p> <ul style="list-style-type: none"> <li>▪ Pressure</li> </ul> <p><b>Measured values for QV (fourth variable)</b></p> <ul style="list-style-type: none"> <li>▪ Temperature</li> </ul>
Supported functions	<ul style="list-style-type: none"> <li>▪ Burst mode</li> <li>▪ Additional transmitter status</li> <li>▪ Device locking</li> <li>▪ Alternative operating modes</li> </ul>

### PROFIBUS PA

Manufacturer ID	17 (11 hex)
Identification number	154F hex
Profile version	3.0 <ul style="list-style-type: none"> <li>▪ SW version 03.00.zz</li> <li>▪ SW version 04.00.zz</li> </ul> 3.02 <ul style="list-style-type: none"> <li>▪ SW version 04.01.zz (device revision 3)</li> </ul> Compatible as of SW 03.00.zz and higher.
GSD revision	<ul style="list-style-type: none"> <li>▪ 4 (SW version 3.00.zz and 4.00.zz)</li> <li>▪ 5 (device revision 3)</li> </ul>
DD Revision	<ul style="list-style-type: none"> <li>▪ 1 (SW version 3.00.zz and 4.00.zz)</li> <li>▪ 1 (device revision 3)</li> </ul>
GSD file	Information and files at:
DD files	<ul style="list-style-type: none"> <li>▪ www.endress.com</li> <li>▪ www.profibus.org</li> </ul>

Output values	<b>Measured value for PV (via Analog Input Function Block)</b> <ul style="list-style-type: none"> <li>■ Pressure</li> <li>■ Level</li> <li>■ Tank content</li> </ul> <b>Measured value for SV</b> <ul style="list-style-type: none"> <li>■ Pressure</li> <li>■ Temperature</li> </ul>
Input values	Input value from PLC for transmission to display
Supported functions	<ul style="list-style-type: none"> <li>■ Identification &amp; maintenance Simplest device identification on the part of the control system and nameplate</li> <li>■ Condensed status<sup>1)</sup></li> <li>■ Automatic ID number adjustment and switchable to the following ID numbers<sup>1)</sup>: <ul style="list-style-type: none"> <li>- 9700: Profile-specific identification number of the transmitter with the "Classic" or "Condensed" status.</li> <li>- 1503: Compatibility mode for the old Deltapilot S generation (DB50, DB50L, DB51, DB52, DB53).</li> <li>- 154F: Identification number for the new Deltapilot S generation (FMB70).</li> </ul> </li> <li>■ Device locking: The device can be locked by hardware or software.</li> </ul>

1) Only with Profile Version 3.02

#### FOUNDATION Fieldbus

Manufacturer ID	452B48 hex
Device type	100B hex
Device revision	<ul style="list-style-type: none"> <li>■ 6 - SW version 03.00.zz</li> <li>■ 7 - SW version 04.00.zz (FF-912)</li> </ul>
DD revision	<ul style="list-style-type: none"> <li>■ 3 (device revision 6)</li> <li>■ 2 (device revision 7)</li> </ul>
CFF revision	<ul style="list-style-type: none"> <li>■ 4 (device revision 6)</li> <li>■ 1 (device revision 7)</li> </ul>
DD files	Information and files at:
CFF files	<ul style="list-style-type: none"> <li>■ www.endress.com</li> <li>■ www.fieldbus.org</li> </ul>
Device tester version (ITK version)	<ul style="list-style-type: none"> <li>■ 5.0 (device revision 6)</li> <li>■ 6.01 (device revision 7)</li> </ul>
Number of ITK test campaign	<ul style="list-style-type: none"> <li>■ IT054800 (device revision 6)</li> <li>■ IT085600 (device revision 7)</li> </ul>
Link-Master (LAS) capable	Yes
Choose from "Link Master" and "Basic Device"	yes; factory setting: basic device
Node address	Factory setting: 247 (F7 hex)
Supported functions	Field diagnostics profile <sup>1)</sup> The following methods are supported: <ul style="list-style-type: none"> <li>■ Restart</li> <li>■ Configure error as warning or alarm</li> <li>■ HistoROM</li> <li>■ Peakhold</li> <li>■ Alarm info</li> <li>■ Sensor trim</li> </ul>
Number of VCRs	<ul style="list-style-type: none"> <li>■ 44 (device revision 6)</li> <li>■ 24 (device revision 7)</li> </ul>
Number of Link Objects in VFD	50

1) Only with FF912

*Virtual communication references (VCRs)*

	Device revision 6	Device revision 7
Permanent Entries	44	1
Client VCRs	0	0
Server VCRs	5	10
Source VCRs	8	43
Sink VCRs	0	0
Subscriber VCRs	12	43
Publisher VCRs	19	43

*Link settings*

	Device revision 6	Device revision 7
Slot time	4	4
Min. inter PDU delay	12	10
Max. response delay	10	10

*Transducer Blocks*

Block	Content	Output values
TRD1 Block	Contains all parameters related to the measurement	<ul style="list-style-type: none"> <li>▪ Pressure or level (channel 1)</li> <li>▪ Process temperature (channel 2)</li> </ul>
Service Block	Contains service information	<ul style="list-style-type: none"> <li>▪ Pressure after damping (channel 3)</li> <li>▪ Pressure peakhold indicator (channel 4)</li> <li>▪ Counter for max. pressure transgressions (channel 5)</li> </ul>
Diagnostic Block	Contains diagnostic information	Error code via DI channels (channel 0 to 16)
Display Block	Contains parameters to configure the onsite display	No output values

## Function blocks

Block	Content	Number of blocks	Execution time		Functionality	
			Device revision 6	Device revision 7	Device revision 6	Device revision 7
Resource Block	This block contains all the data that uniquely identify the device; it is an electronic version of a nameplate for the device.	1			enhanced	enhanced
Analog Input Block 1 Analog Input Block 2	The AI Block receives the measuring data from the Sensor Block, (selectable via a channel number) and makes the data available to other function blocks at its output. Enhancement: digital outputs for process alarms, fail safe mode	2	45 ms	45 ms <sup>1)</sup>	enhanced	enhanced
Digital Input Block	This block contains the discrete data of the Diagnose Block (selectable via a channel number 0 to 16) and provides them for other blocks at the output.	1	40 ms	30 ms	standard	enhanced
Digital Output Block	This block converts the discrete input and thus initiates an action (selectable via a channel number) in the DP Flow Block or in the Service Block. Channel 1 resets the counter for max. pressure transgressions..	1	60 ms	40 ms	standard	enhanced
PID Block	The PID Block serves as a proportional-integral-derivative controller and is used almost universally for closed-loop-control in the field including cascade and feedforward. Input IN can be indicated on the display. The selection is performed in the Display Block (DISPLAY_MAIN_LINE_CONTENT).	1	120 ms	70 ms	standard	enhanced
Arithmetic Block	This block is designed to permit simple use of popular measurement math functions. The user does not have to know how to write equations. The math algorithm is selected by name, chosen by the user for the function to be performed.	1	50 ms	40 ms	standard	enhanced
Input Selector Block	The Input Selector Block facilitates the selection of up to four inputs and generates an output based on the configured action. This block normally receives its inputs from AI Blocks. The block performs maximum, minimum, average and 'first good' signal selection. Inputs IN1 to IN4 can be indicated on the display. The selection is performed in the Display Block (DISPLAY_MAIN_LINE_CONTENT).	1	35 ms	35 ms	standard	enhanced
Signal Characterizer Block	The Signal Characterizer Block has two sections, each with an output that is a non-linear function of the respective input. The non-linear function is generated by a single look-up table with 21 arbitrary x-y pairs.	1	30 ms	40 ms	standard	enhanced
Integrator Block	The Integrator Block integrates a variable as a function of the time or accumulates the counts from a Pulse Input Block. The block may be used as a totalizer that counts up until reset or as a batch totalizer that has a setpoint, where the integrated or accumulated value is compared to pre-trip and trip settings, generating a binary signal when the setpoint is reached.	1	35 ms	40 ms	standard	enhanced
Analog Alarm Block	This block contains all process alarm conditions (working like a comparator) and represents them at the output.	1	35 ms	35 ms	standard	enhanced

## Additional function block information:

Instantiatable function blocks	YES	YES
Number of additional instantiatable function blocks	11	5

1) Without trend and alarm reports

## Power supply

### ⚠ WARNING

#### Electrical safety is compromised by an incorrect connection!

- ▶ When using the measuring device in hazardous areas, installation must comply with the corresponding national standards and regulations and the Safety Instructions or Installation or Control Drawings → 57 ff. All explosion protection data are given in separate documentation which is available upon request. The Ex documentation is supplied as standard with all devices approved for use in explosion hazardous areas → 57 ff.
- ▶ Devices with integrated overvoltage protection must be grounded. → 22
- ▶ Protective circuits against reverse polarity, HF influences and overvoltage peaks are installed.

### Terminal assignment

#### 4 to 20 mA HART

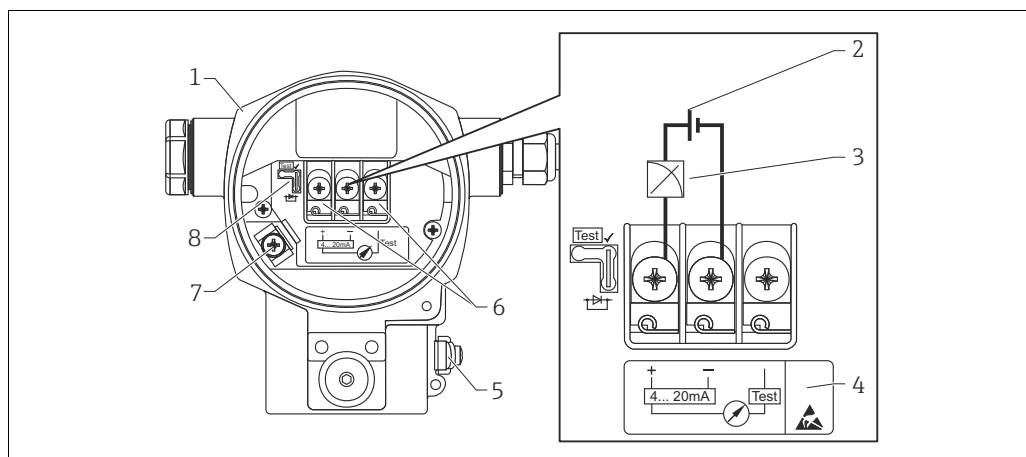

A0019989

Terminal assignment, shown here with aluminum housing (T14)

- 1 Housing
- 2 Supply voltage
- 3 4 to 20 mA
- 4 Devices with integrated overvoltage protection are labeled "OVP" (overvoltage protection) here.
- 5 External ground terminal
- 6 4 to 20 mA test signal between positive and test terminal
- 7 Internal ground terminal
- 8 Jumper for 4 to 20 mA test signal → 19, "Measuring a 4 to 20 mA test signal" section.

#### PROFIBUS PA and FOUNDATION Fieldbus

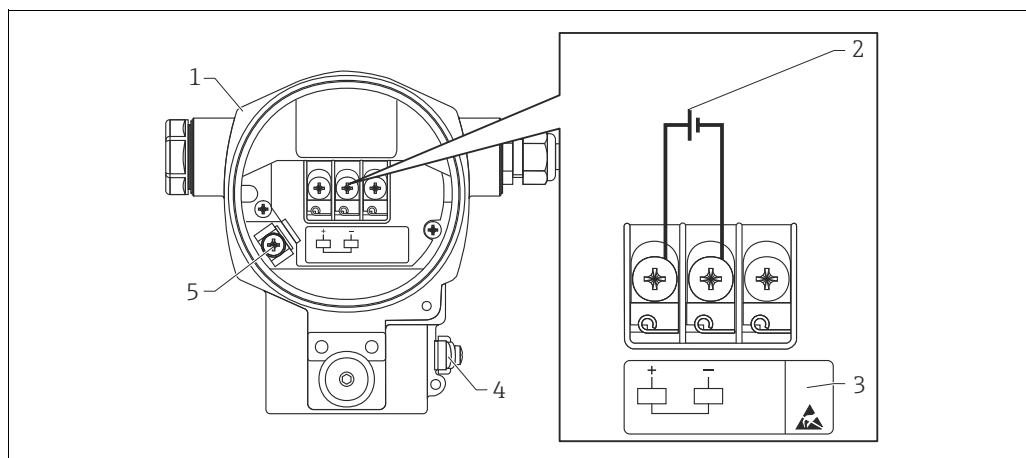

A0020158

Terminal assignment, shown here with aluminum housing (T14)

- 1 Housing
- 3 Supply voltage
- 3 Devices with integrated overvoltage protection are labeled OVP (overvoltage protection) here.
- 4 External ground terminal
- 5 Internal ground terminal



**Supply voltage**

**4 to 20 mA HART**

Version	Jumper for 4 to 20 mA test signal	Supply voltage
Non-hazardous area	in "Test" position	11.5 to 45 V DC
	in "Non-Test" position	10.5 to 45 V DC
Intrinsically safe	in "Test" position	11.5 to 30 V DC
	in "Non-Test" position	10.5 to 30 V DC
<ul style="list-style-type: none"> <li>▪ Other types of protection</li> <li>▪ Uncertified devices</li> </ul>	in "Test" position	11.5 to 45 V DC (versions with 35 V DC plug-in connection)
	in "Non-Test" position	10.5 to 45 V DC (versions with 35 V DC plug-in connection)

*Measuring a 4 to 20 mA test signal*

A 4 to 20 mA test signal may be measured via the positive and test terminal without interrupting the measurement. The minimum supply voltage of the device can be reduced by simply changing the position of the jumper. As a result, operation is also possible with lower voltage sources. Observe the position of the jumper in accordance with the following table.

Jumper position for test signal	Description
 <p style="text-align: right; font-size: small;">A0019992</p>	<ul style="list-style-type: none"> <li>- Measurement of 4 to 20 mA test signal via positive and test terminal: possible. (Thus, the output current can be measured without interruption via the diode.)</li> <li>- Delivery status</li> <li>- Minimum supply voltage: 11.5 V DC</li> </ul>
 <p style="text-align: right; font-size: small;">A0019993</p>	<ul style="list-style-type: none"> <li>- Measurement of 4 to 20 mA test signal via positive and test terminal: not possible.</li> <li>- Minimum supply voltage: 10.5 V DC</li> </ul>

**PROFIBUS PA**

- Version for non-hazardous areas: 9 to 32 V DC
- Ex ia: 10.5 to 30 V DC

**FOUNDATION Fieldbus**

- Version for non-hazardous areas: 9 to 32 V DC
- Ex ia: 10.5 to 30 V DC

**Current consumption**

- PROFIBUS PA: 13 mA ± 1 mA, switch-on current complies with IEC 61158-2, Clause 21
- FOUNDATION Fieldbus: 15.5 mA ± 1 mA, switch-on current complies with IEC 61158-2, Clause 21

**Electrical connection**

**PROFIBUS PA**

The digital communication signal is transmitted to the bus via a 2-wire connection. The bus also provides the power supply. For further information on the network structure and grounding, and for further bus system components such as bus cables, see the relevant documentation, e.g. Operating Instructions BA00034S "PROFIBUS DP/PA: Guidelines for planning and commissioning" and PNO Guideline

**FOUNDATION Fieldbus**

The digital communication signal is transmitted to the bus via a 2-wire connection. The bus also provides the power supply. For further information on the network structure and grounding and for further bus system components such as bus cables, see the relevant documentation, e.g. Operating Instructions BA00013S "FOUNDATION Fieldbus Overview" and the FOUNDATION Fieldbus Guideline.

**Terminals**

For wire cross-sections of 0.5 to 2.5 mm<sup>2</sup> (20 to 14 AWG)

**Cable entry**

Approval	Type	Clamping area
Standard, II1/2G Exia, IS	Plastic M20x1.5	5 to 10 mm (0.2 to 0.39 in)
ATEX II1/2D, II1/3D, II1/2GD Exia, II1GD Exia, II3G Ex nA	Metal M20x1.5 (Ex e)	7 to 10.5 mm (0.28 to 0.41 in)

For additional technical data, see section on housing → 30 ff.

**Device plug connectors**

**Devices with Harting plug Han7D**

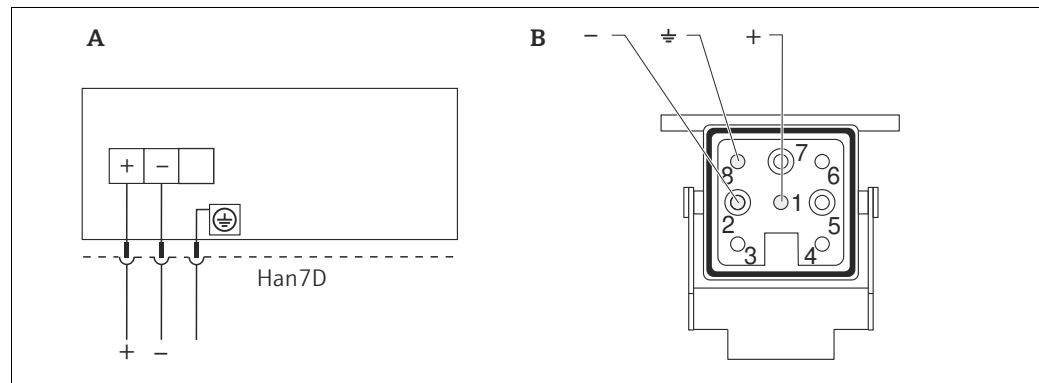

A Electrical connection for devices with Harting plug Han7D  
 B View of the plug-in connection at the device

Material: CuZn, gold-plated contacts of receptacle and connector

**Connection of cable version**

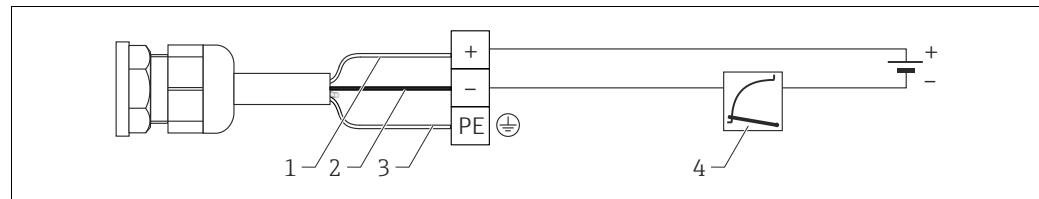

1 rd = red  
 2 bk = black  
 3 gnye = green  
 4 20 mA

**Devices with M12 plug**

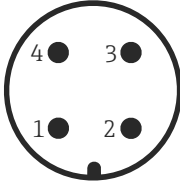
PIN assignment in M12 plug	PIN	Meaning
	1	signal +
	2	not assigned
	3	signal -
	4	ground

Endress+Hauser offers the following accessories for devices with an M12 plug:

Plug-in jack M 12x1, straight

- Material: Body PA; coupling nut CuZn, nickel-plated
- Degree of protection (fully locked): IP67
- Order number: 52006263

Plug-in jack M 12x1, elbowed

- Material: Body PBT/PA; coupling nut GD-Zn, nickel-plated
- Degree of protection (fully locked): IP67
- Order number: 71114212

Cable 4x0.34 mm<sup>2</sup> (20 AWG) with M12 socket, elbowed, screw plug, length 5 m (16 ft)

- Material: Body PUR; coupling nut CuSn/Ni; cable PVC
- Degree of protection (fully locked): IP67
- Order number: 52010285

**Devices with 7/8" plug**

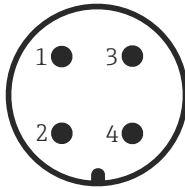
PIN assignment in 7/8" plug	PIN	Meaning
	1	signal -
	2	signal +
	3	not assigned
	4	shield

External thread: 7/8 - 16 UNC

- Material: 316L (1.4401)
- Degree of protection: IP68

**Cable specification****HART**

- Endress+Hauser recommends using shielded, twisted-pair two-wire cables.
- Cable outer diameter: 5 to 9 mm (0.2 to 0.35 in) depending on the cable entry used (→  20)

**PROFIBUS PA**

Use a twisted, shielded two-wire cable, preferably cable type A



For further information on the cable specifications, see Operating Instructions BA00034S "PROFIBUS DP/PA: Guidelines for planning and commissioning", the PNO Guideline 2.092 PROFIBUS PA User and Installation Guideline" and IEC 61158-2 (MBP).

**FOUNDATION Fieldbus**

Use a twisted, shielded two-wire cable, preferably cable type A



For further information on the cable specifications, see Operating Instructions BA00013S "FOUNDATION Fieldbus Overview", FOUNDATION Fieldbus Guideline and IEC 61158-2 (MBP).

**Residual ripple**

without influence on 4 to 20 mA signal up to  $\pm 5\%$  residual ripple within the permitted voltage range [according to HART hardware specification HCF\_SPEC-54 (DIN IEC 60381-1)]

**Overvoltage protection (optional)**

- Overvoltage protection:
  - Nominal functioning DC voltage: 600 V
  - Nominal discharge current: 10 kA
- Surge current check  $\hat{i} = 20$  kA satisfied as per DIN EN 60079-14: 8/20  $\mu$ s
- Arrester AC current check  $I = 10$  A satisfied

Ordering information :

Product configurator "Additional option 1" or Additional option 1" ordering feature, option "M".

**HINWEIS****Device could be destroyed!**

- ▶ Devices with integrated overvoltage protection must be grounded.

**Influence of power supply**

$\leq 0.0006\%$  of URL/1 V

## Performance characteristics

### Reference operating conditions

- As per IEC 60770
- Ambient temperature  $T_A$  = constant, in the range of: +21 to +33°C (+70 to +91°F)
- Humidity  $\varphi$  = constant, in the range of: 5 to 80 % RH
- Ambient pressure  $p_A$  = constant, in the range of: 860 to 1060 mbar (12.47 to 15.37 psi)
- Position of the measuring cell = constant, in range: horizontal  $\pm 1^\circ$
- Input of LOW SENSOR TRIM and HIGH SENSOR TRIM for lower range value and upper range value
- Zero based span
- Process isolating diaphragm material: Alloy C276 (2.4819)
- Filling oil: synthetic oil / inert oil
- Supply voltage: 24 V DC  $\pm$  3 V DC
- Load with HART: 250  $\Omega$

### Long-term stability

Measuring cell	% of URL/1 year	% of URL/5 years
100 mbar (1.5 psi)	$\pm 0.18$	$\pm 0.45$
400 mbar (6 psi) 1200 mbar (18 psi)	$\pm 0.1$	$\pm 0.25$
4000 mbar (60 psi), 10000 mbar (150 psi)	$\pm 0.05$	$\pm 0.125$

### Influence of the installation position

Maximum:  $\pm 2.3$  mbar (0.0345 psi). The value is doubled for devices with inert oil.



Position-dependent zero shift can be corrected. See → [25](#), "General installation instructions" section.

### Resolution

- Current output: 1  $\mu$ A
- Display: can be set (factory setting: presentation of the maximum accuracy of the transmitter)

### Reference accuracy

The reference accuracy comprises the non-linearity according to limit point setting, hysteresis and non-reproducibility as per IEC 60770. The data refer to the calibrated span.

Measuring cell	% of the set span	
	standard	Platinum
100 mbar (1.5 psi)	<ul style="list-style-type: none"> <li>■ TD 1:1 to TD 2:1 = <math>\pm 0.15</math></li> <li>■ TD &gt; 2:1 to TD 4:1 = <math>\pm 0.075 \times</math> TD</li> </ul>	<ul style="list-style-type: none"> <li>■ TD 1:1 to TD 2:1 = <math>\pm 0.1</math></li> <li>■ TD &gt; 2:1 to TD 4:1 = <math>\pm 0.05 \times</math> TD</li> </ul>
400 mbar (6 psi)	<ul style="list-style-type: none"> <li>■ TD 1:1 to TD 4:1 = <math>\pm 0.15</math></li> <li>■ TD &gt; 4:1 to TD 10:1 = <math>\pm 0.0375 \times</math> TD</li> </ul>	<ul style="list-style-type: none"> <li>■ TD 1:1 to TD 4:1 = <math>\pm 0.1</math></li> <li>■ TD &gt; 4:1 to TD 10:1 = <math>\pm 0.025 \times</math> TD</li> </ul>
1200 mbar (18 psi)	<ul style="list-style-type: none"> <li>■ TD 1:1 to TD 2:1 = <math>\pm 0.1</math></li> <li>■ TD &gt; 2:1 to TD 12:1 = <math>\pm 0.05 \times</math> TD</li> </ul>	<ul style="list-style-type: none"> <li>■ TD 1:1 to TD 2:1 = <math>\pm 0.075</math></li> <li>■ TD &gt; 2:1 to TD 12:1 = <math>\pm 0.0375 \times</math> TD</li> </ul>
4000 mbar (60 psi)	<ul style="list-style-type: none"> <li>■ TD 1:1 to TD 4:1 = <math>\pm 0.1</math></li> <li>■ TD &gt; 4:1 to TD 40:1 = <math>\pm 0.025 \times</math> TD</li> </ul>	<ul style="list-style-type: none"> <li>■ TD 1:1 to TD 4:1 = <math>\pm 0.075</math></li> <li>■ TD &gt; 4:1 to TD 40:1 = <math>\pm 0.02 \times</math> TD</li> </ul>
10000 mbar (150 psi)	<ul style="list-style-type: none"> <li>■ TD 1:1 to TD 2.5:1 = <math>\pm 0.1</math></li> <li>■ TD &gt; 2.5:1 to TD 40:1 = <math>\pm 0.04 \times</math> TD</li> </ul>	<ul style="list-style-type: none"> <li>■ TD 1:1 to TD 2.5:1 = <math>\pm 0.075</math></li> <li>■ TD &gt; 2.5:1 to TD 40:1 = <math>\pm 0.03 \times</math> TD</li> </ul>

### Total performance

The "Total performance" specification comprises the non-linearity including hysteresis, non-reproducibility as well as the thermal change in the zero point.

All specifications apply to the temperature range  $-10$  to  $+60$  °C ( $+14$  to  $+140$  °F) and a turn down of 1:1.

Measuring cell	% of URL	
	standard	Platinum
100 mbar (1.5 psi), 400 mbar (6 psi)	$\pm 0.35$	$\pm 0.25$
1200 mbar (18 psi), 4000 mbar (60 psi), 10000 mbar (150 psi)	$\pm 0.15$	$\pm 0.12$

**Total error**

The total error comprises the long-term stability and the total performance.

All specifications apply to the temperature range  $-10$  to  $+60$  °C ( $+14$  to  $+140$  °F) and a turn down of 1:1.

Measuring cell	% of URL/year	
	standard	Platinum
100 mbar (1.5 psi)	$\pm 0.53$	$\pm 0.43$
400 mbar (6 psi)	$\pm 0.45$	$\pm 0.35$
1200 mbar (18 psi)	$\pm 0.25$	$\pm 0.22$
4000 mbar (60 psi), 10000 mbar (150 psi)	$\pm 0.20$	$\pm 0.17$

**Warm-up period**

- 4 to 20 mA HART: 10 s
- PROFIBUS PA: 6 s
- FOUNDATION Fieldbus: 50 s

**Thermal change of the zero output and the output span**

Measuring cell	% of the set span			
	$-10$ to $+60$ °C ( $+14$ to $140$ °F)		$+60$ to $+85$ °C ( $+140$ to $185$ °F)	
	standard	Platinum	standard	Platinum
100 mbar (1.5 psi)	$\pm(0.3 \times \text{TD} + 0.02)$	$\pm(0.2 \times \text{TD} + 0.02)$	$\pm(0.4 \times \text{TD} + 0.04)$	$\pm(0.3 \times \text{TD} + 0.04)$
400 mbar (6 psi)	$\pm(0.25 \times \text{TD} + 0.01)$	$\pm(0.15 \times \text{TD} + 0.01)$	$\pm(0.3 \times \text{TD} + 0.02)$	$\pm(0.2 \times \text{TD} + 0.02)$
1200 mbar (18 psi), 4000 mbar (60 psi), 10000 mbar (150 psi)	$\pm(0.1 \times \text{TD} + 0.01)$	$\pm(0.075 \times \text{TD} + 0.01)$	$\pm(0.15 \times \text{TD} + 0.02)$	$\pm(0.1 \times \text{TD} + 0.02)$

These values specify the thermal change for the most unfavorable situation where the process temperature and the ambient temperature change independently of each other.

## Installation

---

### General installation instructions

- The position-dependent zero point shift can be corrected directly at the device via an operating key, and also in hazardous areas in the case of devices with external operation.
- The housing of the Deltapilot S can be rotated up to 380°. See → [427](#), "Turning the housing" section.
- The onsite display can be rotated in 90° stages.
- For mounting the device on pipes or walls, Endress+Hauser offers a mounting bracket → [425](#), "Wall and pipe-mounting" section.

### Level measurement

- Always install the device below the lowest measuring point.
- Do not install the device at the following positions:
  - in the filling curtain
  - in the tank outflow
  - or at a point in the tank that can be affected by pressure pulses from the agitator
- The adjustment and functional test can be carried out more easily if you mount the device downstream of a shutoff device.
- The Deltapilot S must be included in the insulation for media that can harden when cold.

### Pressure measurement in gases

Mount Deltapilot S with shutoff device above the tapping point so that any condensate can flow into the process.

### Pressure measurement in steams

- Mount Deltapilot S with siphon above the tapping point.  
The siphon reduces the temperature to almost the ambient temperature.
- Fill the siphon with liquid before commissioning.

### Pressure measurement in liquids

Mount Deltapilot S with shutoff device below or at the same level as the tapping point.

---

### Wall and pipe-mounting

Endress+Hauser offers a mounting bracket for installing the device on pipes or walls. The mounting bracket can be installed on pipes with a diameter of 1¼" to 2" or on walls.

Ordering information :

Product Configurator, "Additional options" ordering feature, option "U" or Product Configurator "Enclosed accessories" ordering feature, option "PA" or as a separate accessory (part no.: 71102216).

Dimensions → [440](#).

**"Separate housing" version**

With the "separate housing" version, you are able to mount the housing with the electronics insert at a distance from the measuring point. This version facilitates trouble-free measurement:

- Under particularly difficult measuring conditions (at installation locations that are cramped or difficult to access)
- If rapid cleaning of the measuring point is required
- If the measuring point is exposed to vibrations
- For compact installations

You can choose between different cable versions:

- PE: 2 m (6.6 ft), 5 m (16 ft) and 10 m (33 ft)
- FEP: 5 m (16 ft).

Ordering information :

Product Configurator, "Additional options" ordering feature, option "G".

Dimensions →  40.

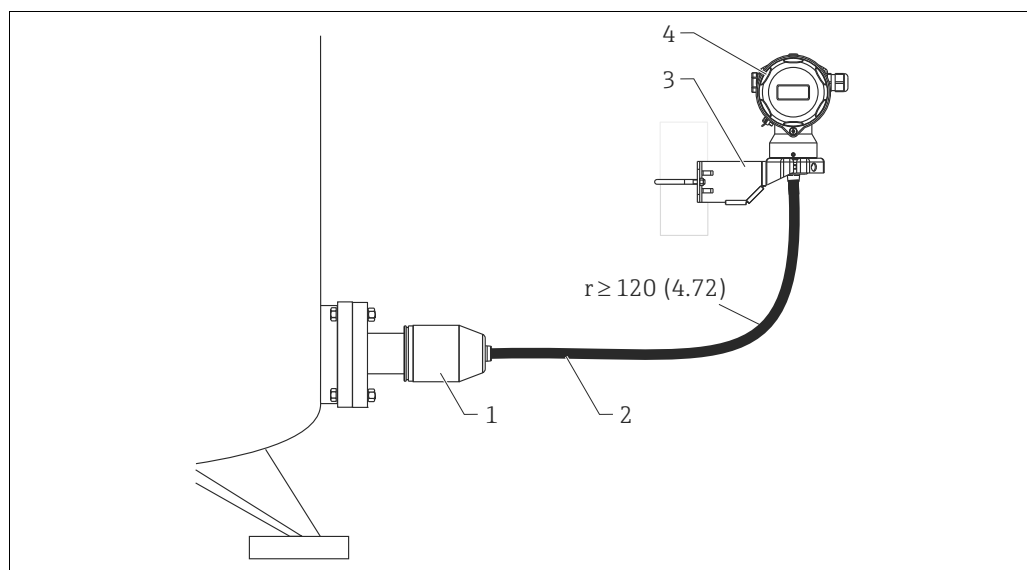

A0019994

Engineering unit mm (in)

In the case of the "separate housing" version, the sensor is delivered with the process connection and cable ready mounted. The housing and a mounting bracket are enclosed as separate units. The cable is provided with a socket at both ends. These sockets are simply connected to the housing and the sensor.

- 1 Process connection with sensor - For degrees of protection, see the following section
- 2 Cable, both ends are fitted with a socket
- 3 Mounting bracket provided, suitable for pipe and wall mounting
- 4 Housing with electronic insert - Degrees of protection →  30 ff

Degree of protection for the process connection and sensor with the use of

- FEP cable:
  - IP 69K
  - IP 66 NEMA 4/6P
  - IP 68 (1.83 mH<sub>2</sub>O for 24 h) NEMA 4/6P
- PE cable:
  - IP 66 NEMA 4/6P
  - IP 68 (1.83 mH<sub>2</sub>O for 24 h) NEMA 4/6P

Technical data of the PE and FEP cable:

- Minimum bending radius: 120 mm (4.72 in)
- Cable extraction force: max. 450 N
- Resistance to UV light

Use in hazardous area:

- Intrinsically safe installations (Ex ia/IS)
- FM/CSA IS: for Div.1 installation only

### Reduction of the installation height

If the separate housing is used, the installation height of the process connection is reduced compared to the dimensions of the standard version.

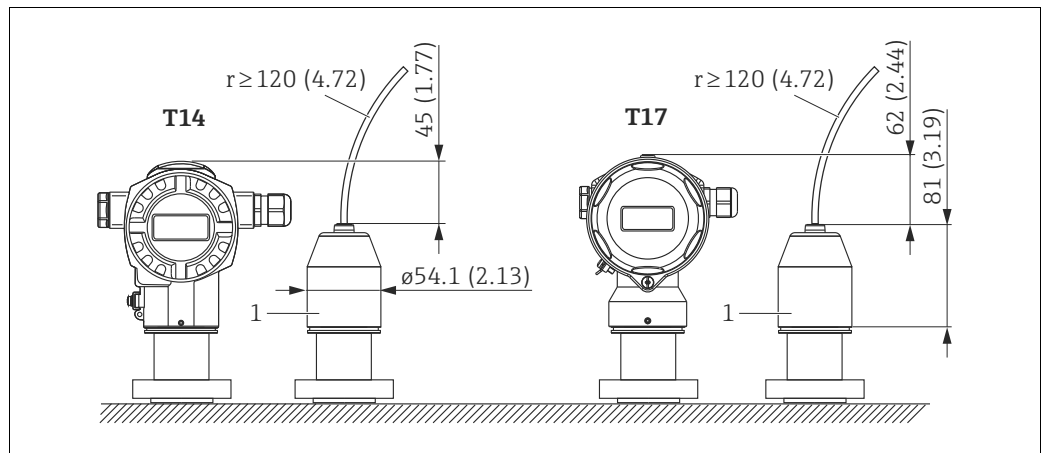

A0019996

Engineering unit mm (in)

1 Process connection adapter.

### Turning the housing

The housing can be rotated up to 380° by loosening the Allen screw.

#### Your benefits

- Simple mounting by optimally aligning the housing
- Good, accessible device operation
- Optimum readability of the onsite display (optional).

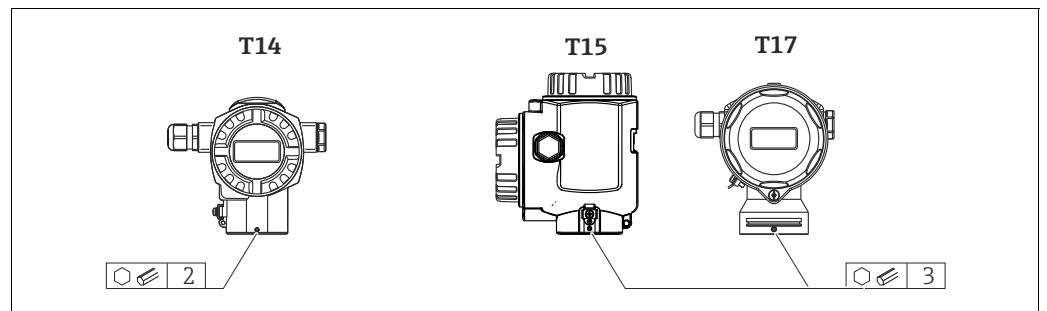

A0019996

### Silicone-free applications

Special cleaning of the transmitter to remove paint-wetting substances, for use in paint shops for example.

Ordering information :

Product Configurator, "Seal" ordering feature, option "L".

### Applications with hydrogen

With regard to materials in which hydrogen formation takes place, hydrogen atoms can diffuse through the metals of the sensor. This can result in incorrect measurement results. Endress+Hauser offers process isolating diaphragms with gold-rhodium coating for this application.

Ordering information :

Product Configurator, "Material of the process isolating diaphragm" ordering feature, option "6".

## Environment

- Ambient temperature range**
- -40 to +85 °C (-40 to +185 °F)  
lower temperatures on request
  - Onsite display: -20 to +70°C (-4 to +158 °F)  
Extended temperature application range with restrictions in optical properties, such as display speed and contrast: -40 to +85 °C (-40 to +185 °F)
  - Separate housing: -20 to +60 °C (-4 to +140 °F) (installation without insulation)
- For devices for use in hazardous areas, see Safety Instructions, Installation or Control Drawing (→ 57 ff, "Safety Instructions" and "Installation/ Control Drawings" sections).

The device can be used in the temperatures ranges mentioned. The values of the specification, such as thermal change, may be exceeded.

### Hazardous areas

- Pressure measuring devices that have the common explosion protection certificates (e.g. ATEX/FM/ CSA/ IEC Ex etc.) can be used in hazardous areas with ambient temperatures down to -50 °C (-58 °F). The explosion protection functionality can be guaranteed down to -50 °C (-58 °F) ambient temperature.
- The nameplate specification is limited to an ambient temperature of -40 °C (-40 °F) as all the metrological device tests are only performed down to temperatures of -40 °C (-40 °F). If the device is operated at an ambient temperature below -40 °C (-40 °F), the technical specifications in this document no longer apply. Functional restrictions can be expected.

- Storage temperature range**
- -40 to +90 °C (-40 to +194 °F)
  - Onsite display: -40 to +85 °C (-40 to +185 °F)
  - Separate housing: -40 to +60 °C (-40 to +140 °F)

- Degree of protection**
- Housing → 30 ff
  - Separate housing → 26

**Climate class** Class 4K4H (air temperature: -20 to 55 °C (-4 to 131 °F), relative humidity: 4 to 100 %) fulfilled as per DIN EN 60721-3-4 (condensation possible)

### Vibration resistance

Device/accessory	Test standard	Vibration resistance
FMB70	GL	Guaranteed for: 3 to 25 Hz: ±1.6 mm (0.063 in); 25 to 100 Hz: 4 g in all 3 planes
FMB70 with mounting bracket	IEC 61298-3	Guaranteed for: 10 to 60 Hz: ±0.15 mm (0.0059 in); 60 to 500 Hz: 2 g in all 3 planes

- Electromagnetic compatibility**
- Electromagnetic compatibility to EN 61326 and NAMUR recommendation EMC (NE21). For details refer to the Declaration of Conformity.
  - Maximum deviation: < 0.5 % of span
  - All EMC measurements were performed with a turn down (TD) = 2:1.

---

## Process

---



### Process temperature limits

- -10 to +100 °C (+14 to 212 °F)
- Up to +135°C (+275°F) short-term (for 30 minutes) for cleaning purposes

---

### Pressure specifications

**▲ WARNING**

The maximum pressure for the measuring device depends on the lowest rated element with regard to pressure →  10 ff, "Measuring range" and →  30 ff "Mechanical construction" section.

- ▶ The measuring device must be operated only within the specified limits!
- ▶ The MWP (maximum working pressure) is specified on the nameplate. This value refers to a reference temperature of +20°C (68°F), or 100°F (38 °C) for ASME flanges, and may be applied to the device for an unlimited time. Observe pressure-temperature dependency.
- ▶ The pressure values permitted at higher temperatures can be found in the standards EN 1092-1: 2001 Tab. 18 <sup>1)</sup>  
ASME B 16.5a – 1998 Tab. 2-2.2 F316  
ASME B 16.5a – 1998 Tab. 2.3.8 N10276  
JIS B 2220.
- ▶ The test pressure corresponds to the over pressure limit of the measuring device (OPL = 1.5 x MWP) and may only be applied temporarily so that no permanent damage develops.
- ▶ The Pressure Equipment Directive (EC Directive 97/23/EC) uses the abbreviation "PS". The abbreviation "PS" corresponds to the MWP (maximum working pressure) of the measuring device.
- ▶ In the case of sensor range and process connections where the over pressure limit (OPL) of the process connection is smaller than the nominal value of the sensor, the device is set at the factory, at the very maximum, to the OPL value of the process connection. If you want to use the entire sensor range, select a process connection with a higher OPL value (1.5 x PN; MWP = PN).

---

1) With regard to their stability-temperature property, the materials 1.4435 and 1.4404 are grouped together under 13E0 in EN 1092-1: 2001 Tab. 18. The chemical composition of the two materials can be identical.

## Mechanical construction

### Device height

The device height is based on

- the height of the housing and
- the height of the relevant process connection.

The individual heights of the components can be found in the following sections. You can calculate the device height easily by adding the individual heights together. If necessary, the installation space (the space used to install the device) must also be taken into account.

You can use the following table for this:

Section	Page	Height
Height of housing	→ 30 ff	
Process connections	→ 32 ff	
Installation space		
Device height		

### T14 housing, optional display on the side

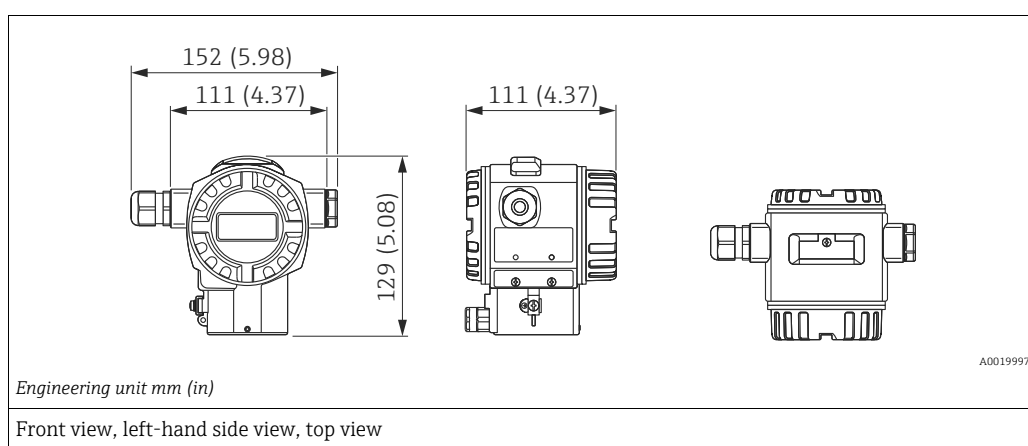

Material		Degree of protection	Cable entry	Weight kg (lbs)		Option <sup>1)</sup>
Housing	Cover seal			with display	without display	
Aluminum	EPDM	IP66/67 NEMA 6P	M20 gland	1.2 (2.65)	1.1 (2.43)	A
		IP66/67 NEMA 6P	G ½" thread			B
		IP66/67 NEMA 6P	NPT ½" thread			C
		IP66/67 NEMA 6P	M12 plug			D
		IP66/67 NEMA 6P	7/8" plug			E
		IP65 NEMA 4	HAN7D plug 90 degrees			F

1) Product Configurator, "Housing, cable entry, degree of protection" ordering feature

**T15 housing, optional display on the top**

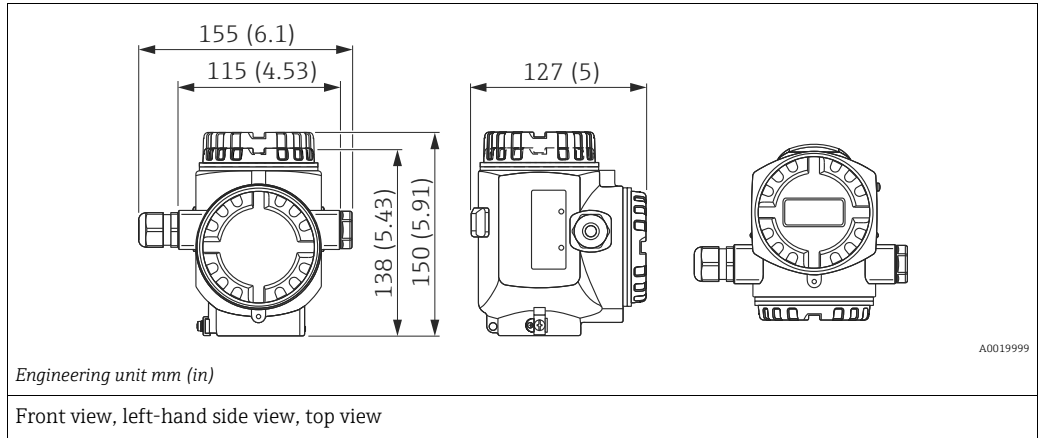

Material		Degree of protection	Cable entry	Weight kg (lbs)		Option <sup>1)</sup>
Housing	Cover seal			with display	without display	
Aluminum	EPDM	IP66/67 NEMA 6P	M20 gland	1.8 (3.97)	1.7 (3.75)	J
		IP66/67 NEMA 6P	G ½" thread			K
		IP66/67 NEMA 6P	NPT ½" thread			L
		IP66/67 NEMA 6P	M12 plug			M
		IP66/67 NEMA 6P	7/8" plug			N
		IP65 NEMA 4	HAN7D plug 90 degrees			P

1) Product Configurator, "Housing, cable entry, degree of protection" ordering feature

**T17 housing (hygienic), optional display on the side**

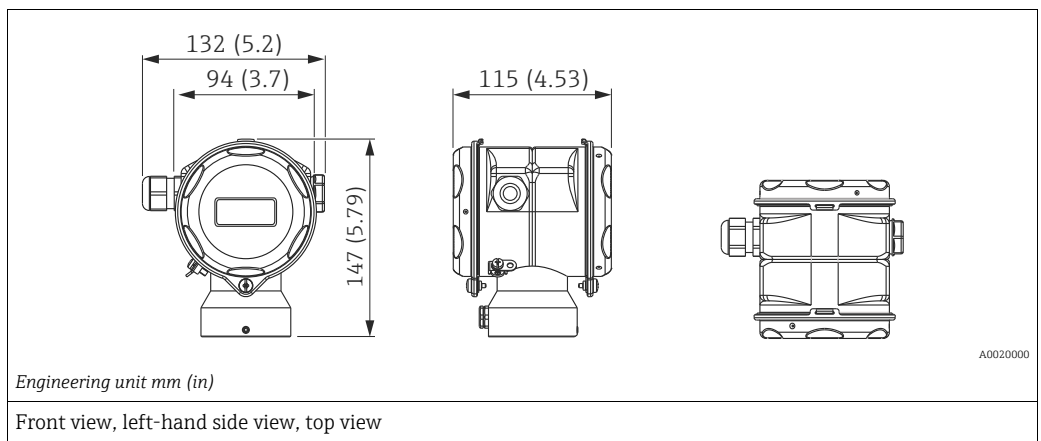

Material		Degree of protection <sup>1)</sup>	Cable entry	Weight kg (lbs)		Option <sup>2)</sup>
Housing	Cover seal			with display	without display	
316L	EPDM	IP66/68 NEMA 6P	M20 gland	1.2 (2.65)	1.1 (2.43)	R
		IP66/68 NEMA 6P	G ½" thread			S
		IP66/68 NEMA 6P	NPT ½" thread			T
		IP66/68 NEMA 6P	M12 plug			U
		IP66/68 NEMA 6P	7/8" plug			V

1) Degree of protection IP 68: 1.83 mH<sub>2</sub>O for 24 h

2) Product Configurator, "Housing, cable entry, degree of protection" ordering feature

## Process connections

## Threaded connection ISO 228 and NPT

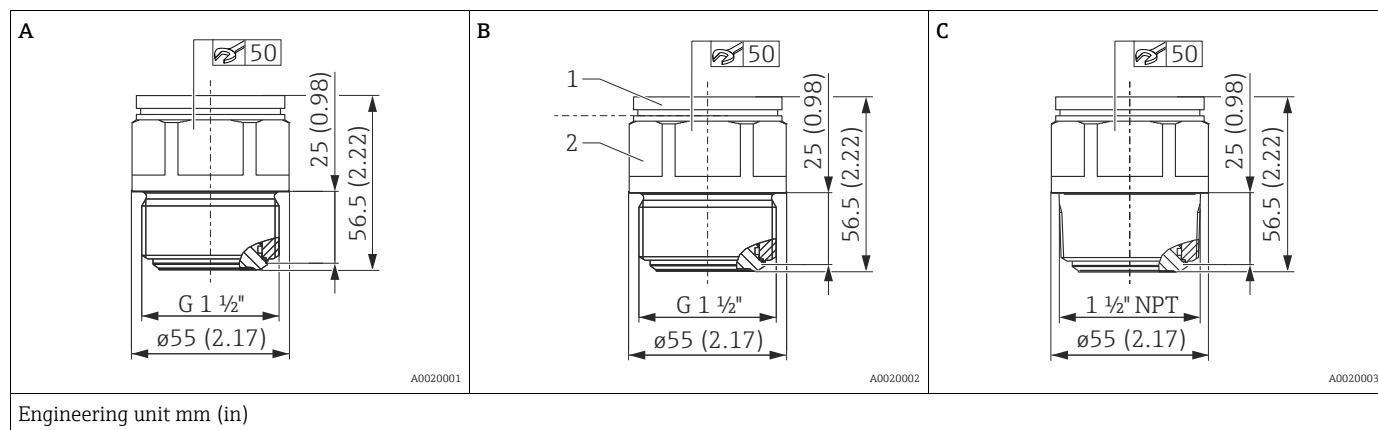

Position	Designation	Material	Weight kg (lbs)	Approval <sup>1)</sup>	Option <sup>2)</sup>
A	Thread ISO 228 G 1 ½" A	AISI 316L (1.4435)	0.8 (1.76)	-	1G
B	Thread ISO 228 G 1 ½" A	<ul style="list-style-type: none"> <li>■ 1: Top section AISI 316L (1.4404)</li> <li>■ 2: Bottom section Alloy C276 (2.4819)</li> </ul>	0.8 (1.76)	-	1H
C	Thread ANSI 1 ½" MNPT	AISI 316L (1.4435)	0.8 (1.76)	CRN	2D

1) CSA approval: Product Configurator, "Approval" ordering feature

2) Product Configurator, "Process connection" ordering feature



Some device versions have CRN approval. For a CRN-approved device, a CRN-approved process connection must be ordered with a CSA approval. These devices are fitted with a separate plate bearing the registration number CRN OF1987.7C.

EN/DIN flanges, connection dimensions as per EN 1092-1/DIN 2527, raised face RF

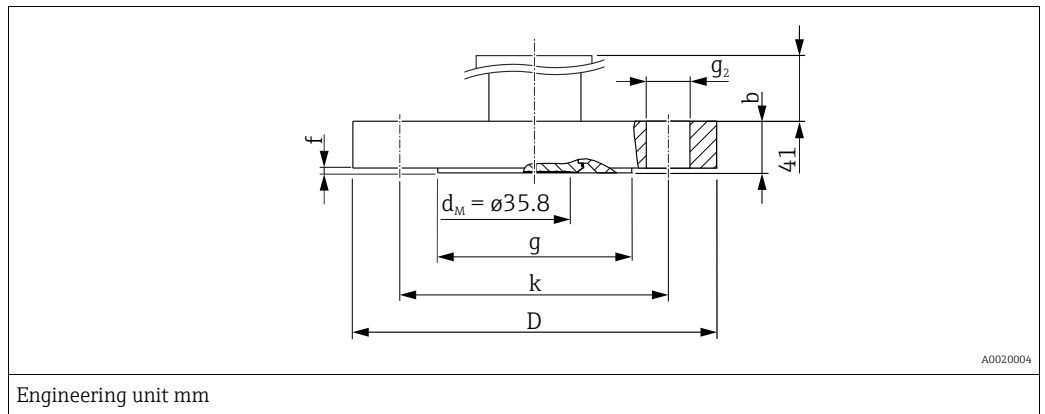

Flange <sup>1)2)</sup>							Boltholes				Option <sup>3)</sup>
Nominal diameter	Nominal pressure	Shape <sup>4)</sup>	Diameter D	Thick-ness b	Diameter of raised face g	Height Raised face f	Quan-tity	Diameter g <sub>2</sub>	Hole circle k	Weight <sup>5)</sup>	
			[mm]	[mm]	[mm]	[mm]		[mm]	[mm]	kg (lbs)	
DN 40	PN 10/16	B1 (C)	150	18	88	2	4	18	110	2.6 (5.73)	CE
DN 50	PN 10/16	B1 (C)	165	18	102	2	4	18	125	3.3 (7.28)	CF
DN 80	PN 10/16	B1 (C)	200	20	138	2	8	18	160	5.1 (11.25)	CG
DN 100	PN 10/16	B1 (C)	220	20	158	2	8	18	180	6.3 (13.89)	CH

- 1) The roughness of the surface in contact with the medium, including the sealing surface of the flanges (all standards) is Ra < 0.8 µm (31.5 in). Lower surface roughness on request.
- 2) AISI 316L material: Endress+Hauser supplies DIN/EN stainless steel flanges as per AISI 316L (DIN/ EN material number 1.4404 or 14435). With regard to their stability-temperature property, the materials 1.4404 and 1.4435 are grouped together under 13E0 in EN 1092-1: 2001 Tab. 18. The chemical composition of the two materials can be identical.
- 3) Product Configurator, "Process connection" ordering feature
- 4) Designation as per DIN 2526 in brackets
- 5) Weight incl. pipe and measuring cell, housing weight → 30 ff

## ASME flanges, connection dimensions as per ASME B 16.5, raised face RF

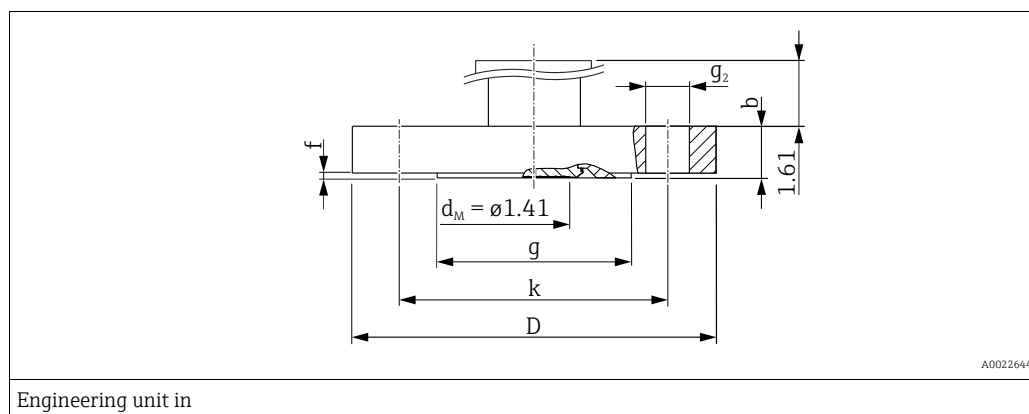

Flange <sup>1)2)</sup>						Boltholes				Approval <sup>3)</sup>	Option <sup>4)</sup>
Nominal diameter	Class	Diameter D	Thick- ness b	Diameter of raised face g	Raised face height f	Qua- ntity	Diame- ter g <sub>2</sub>	Hole circle k	Weight <sup>5)</sup>		
[in]	[lb./sq in]	[in]	[in]	[in]	[in]		[in]	[in]	kg (lbs)		
1 1/2	150	5	0.69	2.88	0.06	4	0.62	3.88	2.1 (4.63)	CRN	AE
2	150	6	0.75	3.62	0.06	4	0.75	4.75	3.0 (6.62)	CRN	AF
3	150	7.5	0.94	5	0.06	4	0.75	6	5.7 (12.57)	CRN	AG
4	150	9	0.94	6.19	0.06	8	0.75	7.5	7.8 (17.2)	CRN	AH

- 1) The roughness of the surface in contact with the medium, including the sealing surface of the flanges (all standards) is Ra < 0.8 µm (31.5 in). Lower surface roughness on request.
- 2) AISI 316/316L material: Combination of AISI 316 for required pressure resistance and AISI 316L for required chemical resistance (dual rated)
- 3) CSA approval: Product Configurator, "Approval" ordering feature
- 4) Product Configurator, "Process connection" ordering feature
- 5) Weight incl. pipe and measuring cell, housing weight → 30 ff



Some device versions have CRN approval. For a CRN-approved device, a CRN-approved process connection must be ordered with a CSA approval. These devices are fitted with a separate plate bearing the registration number CRN OF1987.7C.

JIS flanges, connection dimensions as per JIS B 2220 BL, raised face RF

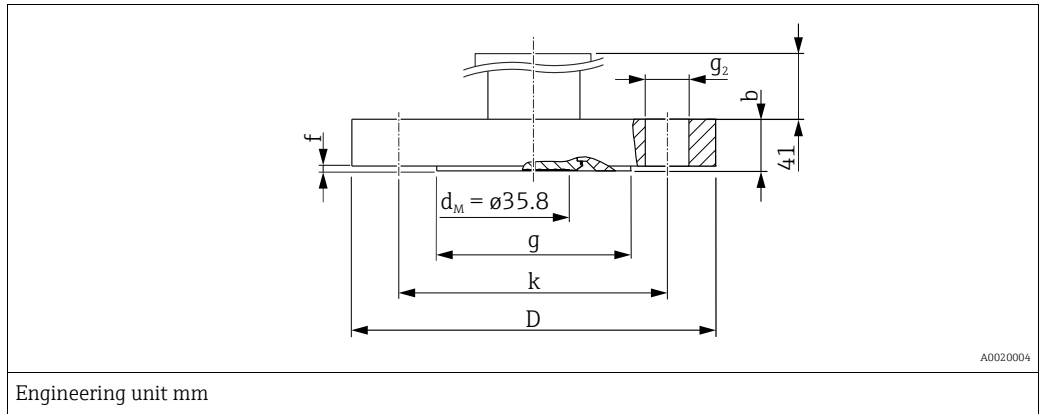

Flange <sup>1)2)</sup>						Boltholes				Option <sup>3)</sup>
Nominal diameter	Nominal pressure	Diameter D	Thick-ness b	Diameter of raised face g	Raised face height f	Quantity	Diameter g <sub>2</sub>	Hole cir- cle k	Flange weight <sup>4)</sup>	
		[mm]	[mm]	[mm]	[mm]		[mm]	[mm]	kg (lbs)	
40 A	10 K	140	16	81	2	4	19	105	2.1 (4.63)	KE
50 A	10 K	155	16	96	2	4	19	120	2.5 (5.51)	KF
80 A	10 K	185	18	126	2	8	19	150	3.8 (8.38)	KL
100 A	10 K	210	18	151	2	8	19	175	4.9 (10.8)	KH

- 1) The roughness of the surface in contact with the medium, including the sealing surface of the flanges (all standards) is Ra < 0.8 μm (31.5 in). Lower surface roughness on request.
- 2) Material: AISI 316L
- 3) Product Configurator, "Process connection" ordering feature
- 4) Weight incl. pipe and measuring cell, housing weight → 30 ff

## Hygienic connections

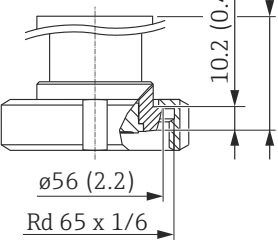
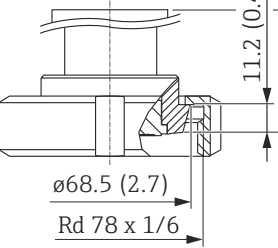
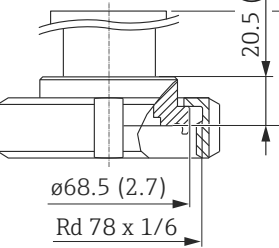
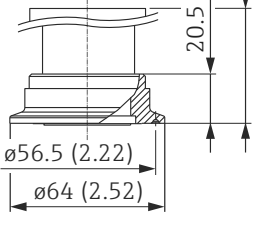
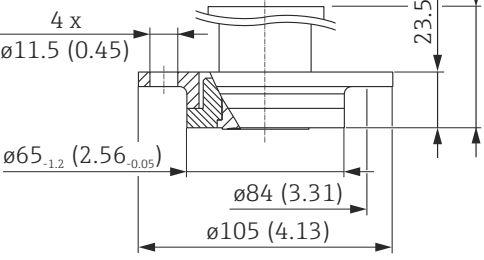
<p><b>A</b></p>  <p><math>\varnothing 56</math> (2.2) Rd 65 x 1/6</p> <p>A0020005</p>	<p><b>B</b></p>  <p><math>\varnothing 68.5</math> (2.7) Rd 78 x 1/6</p> <p>A0020006</p>	<p><b>C</b></p>  <p><math>\varnothing 68.5</math> (2.7) Rd 78 x 1/6</p> <p>A0020007</p>
<p><b>D</b></p>  <p><math>\varnothing 56.5</math> (2.22) <math>\varnothing 64</math> (2.52)</p> <p>A0020008</p>	<p><b>E</b></p>  <p>4 x <math>\varnothing 11.5</math> (0.45) <math>\varnothing 65_{-0.05}</math> (2.56) <math>\varnothing 84</math> (3.31) <math>\varnothing 105</math> (4.13)</p> <p>A0020009</p>	
Engineering unit mm (in)		

Position <sup>1)</sup>	Designation	Nominal pressure	Material	Weight kg (lbs)	Approval <sup>2)</sup>	Option <sup>3)</sup>
A	DIN 11851 DN 40	PN 25	AISI 316L (1.4435)	0.7 (1.54)	EHEDG, 3A, CRN	M2 <sup>4)</sup>
B	DIN 11851 DN 50	PN 25		0.9 (1.98)	EHEDG, 3A, CRN	M3 <sup>4)</sup>
C	DIN 11864-1 A DN 50 Pipe DIN 11866-A, slotted nut	PN 16		1 (2.21)	EHEDG, 3A	ND <sup>4)</sup>
D	Tri-Clamp ISO 2852 DN 40 – DN 51 (2"), DIN 32676 DN 50	-		0.7 (1.54)	EHEDG, 3A, CRN	TD <sup>4)</sup>
E	DRD DN 50 (65 mm), slotted nut AISI 304 (1.4301)	PN 25		1.1 (1.98)	-	TK

- 1) The roughness of the surfaces in contact with the medium is  $R_a \leq 0.76 \mu\text{m}$  (30  $\mu\text{in}$ ) as standard. Surface quality  $R_a < 0.38 \mu\text{m}$  electropolished (wetted), ordering information: Product Configurator, "Additional options 1" and "Additional options 2" ordering feature, option "C"
- 2) CSA approval: Product Configurator, "Approval" ordering feature
- 3) Product Configurator, "Process connection" ordering feature
- 4) Endress+Hauser supplies these slotted nuts in stainless steel AISI 304 (DIN/EN material number 1.4301) or in AISI 304L (DIN/EN material number 1.4307).



Some device versions have CRN approval. For a CRN-approved device, a CRN-approved process connection must be ordered with a CSA approval. These devices are fitted with a separate plate bearing the registration number CRN OF1987.7C.

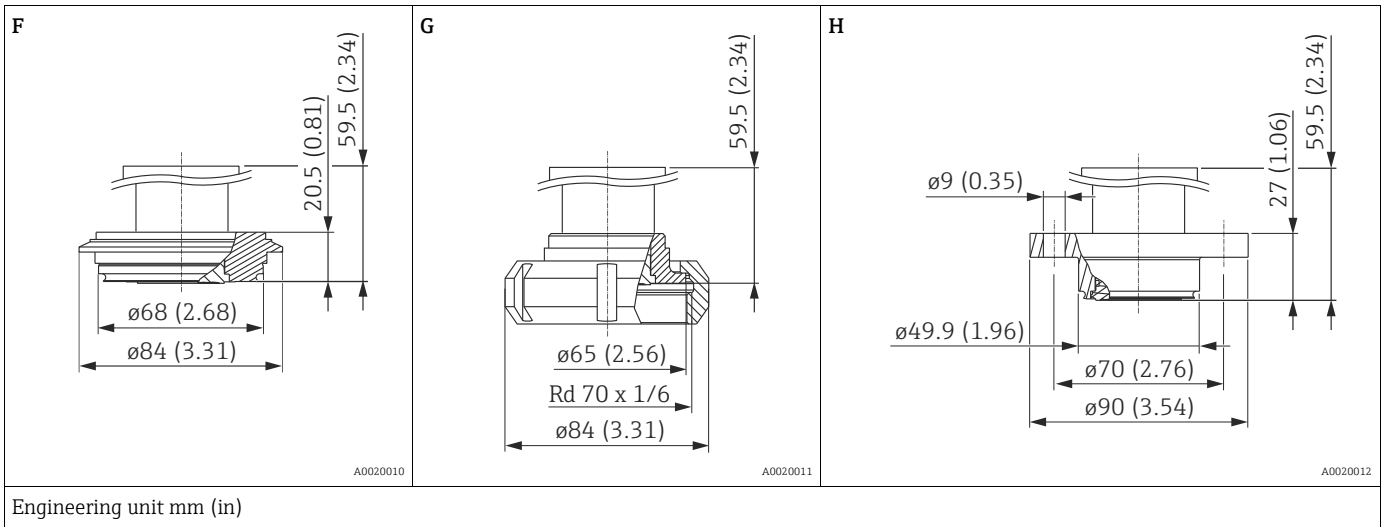

Position <sup>1)</sup>	Designation	Nominal pressure	Material	Weight kg (lbs)	Approval <sup>2)</sup>	Option <sup>3)</sup>
F	Varivent Type N for pipes 40 – 162	PN 40	AISI 316L (1.4435)	1 (2.21)	EHEDG, 3A, CRN	TR
G	SMS 2"	PN 25		0.7 (1.54)	EHEDG, 3A	UE <sup>4)</sup>
H	NEUMO, D50	PN 16		0.8 (1.76)	3A	S4

- 1) The roughness of the surfaces in contact with the medium is  $R_a \leq 0.76 \mu\text{m}$  (30  $\mu\text{in}$ ) as standard. Surface quality  $R_a < 0.38 \mu\text{m}$  electropolished (wetted), ordering information: Product Configurator, "Additional options 1" and "Additional options 2" ordering feature, option "C".
- 2) CSA approval: Product Configurator, "Approval" ordering feature
- 3) Product Configurator, "Process connection" ordering feature
- 4) Endress+Hauser supplies these slotted nuts in stainless steel AISI 304 (DIN/EN material number 1.4301) or in AISI 304L (DIN/EN material number 1.4307).



Some device versions have CRN approval. For a CRN-approved device, a CRN-approved process connection must be ordered with a CSA approval. These devices are fitted with a separate plate bearing the registration number CRN OF1987.7C.

Universal process adapter

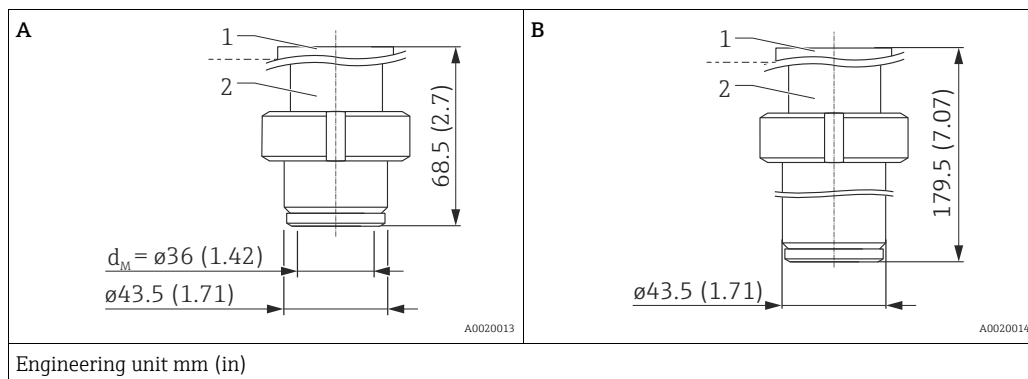

Position <sup>1)</sup>	Designation	Nominal pressure bar (psi)	Material	Weight kg (lbs)	Approval <sup>2)</sup>	Option <sup>3)</sup>
A	Universal process adapter with silicone molded seal <sup>4)</sup>	10 (145)	<ul style="list-style-type: none"> <li>▪ 1: Top section AISI 316L (1.4404)</li> <li>▪ 2: Bottom section AISI 316L (1.4435)</li> </ul>	0.8 (1.76)	EHEDG, 3A, CRN	0 <sup>5)</sup>
	Universal process adapter with EPDM molded seal <sup>6)</sup>				EHEDG, 3A, CRN	1
B	Universal process adapter, 6 inch extension with silicone molded seal <sup>4)</sup>			1.7 (3.75)	EHEDG, 3A, CRN	57 <sup>5)</sup>
	Universal process adapter, 6 inch extension with EPDM molded seal <sup>6)</sup>				EHEDG, 3A, CRN	58

- 1) The roughness of the surfaces in contact with the medium is  $R_a \leq 0.76 \mu\text{m}$  (30  $\mu\text{in}$ ) as standard. Surface quality  $R_a < 0.38 \mu\text{m}$  electropolished (wetted), ordering information: Product Configurator, "Additional options 1" and "Additional options 2" ordering feature, option "C".
- 2) CSA approval: Product Configurator, "Approval" ordering feature
- 3) Product Configurator, "Process connection" ordering feature
- 4) Molded seal FDA 21CFR177.2600/USP Class VI-70C, EHEDG, 3A, spare parts number: 52023572
- 5) Endress+Hauser supplies these slotted nuts in stainless steel AISI 304 (DIN/EN material number 1.4301) or in AISI 304L (DIN/EN material number 1.4307).
- 6) Molded seal EPDM-70, FDA, USP Class VI; (5-part set), order number: 71100719



Some device versions have CRN approval. For a CRN-approved device, a CRN-approved process connection must be ordered with a CSA approval. These devices are fitted with a separate plate bearing the registration number CRN OF1987.7C.

Anderson process adapter

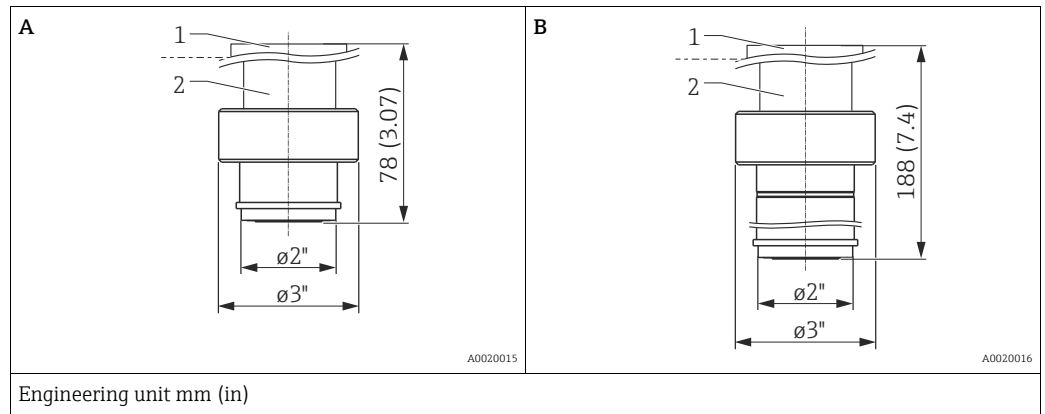

Position <sup>1)</sup>	Designation	Nominal pressure bar (psi)	Material	Weight kg (lbs)	Approval	Option <sup>2)</sup>
A	Anderson process adapter, short 2-3/16", incl. silicone molded seal	6,9 (100)	<ul style="list-style-type: none"> <li>■ 1: Top section AISI 316L (1.4404)</li> <li>■ 2: Bottom section AISI 316L (1.4435)</li> <li>■ Slotted nut AISI 316L (1.4404)</li> </ul>	0.8 (1.76)	3A	60
B	Anderson process adapter, long 6-1/2", incl. silicone molded seal			1.7 (3.75)		

1) The roughness of the surfaces in contact with the medium is  $R_a \leq 0.76 \mu\text{m}$  (30  $\mu\text{in}$ ) as standard.  
Surface quality  $R_a < 0.38 \mu\text{m}$  electropolished (wetted), ordering information: Product Configurator, "Additional options 1" and "Additional options 2" ordering feature, option "C".

2) Product Configurator, "Process connection" ordering feature

Separate housing:  
wall and pipe mounting with  
mounting bracket

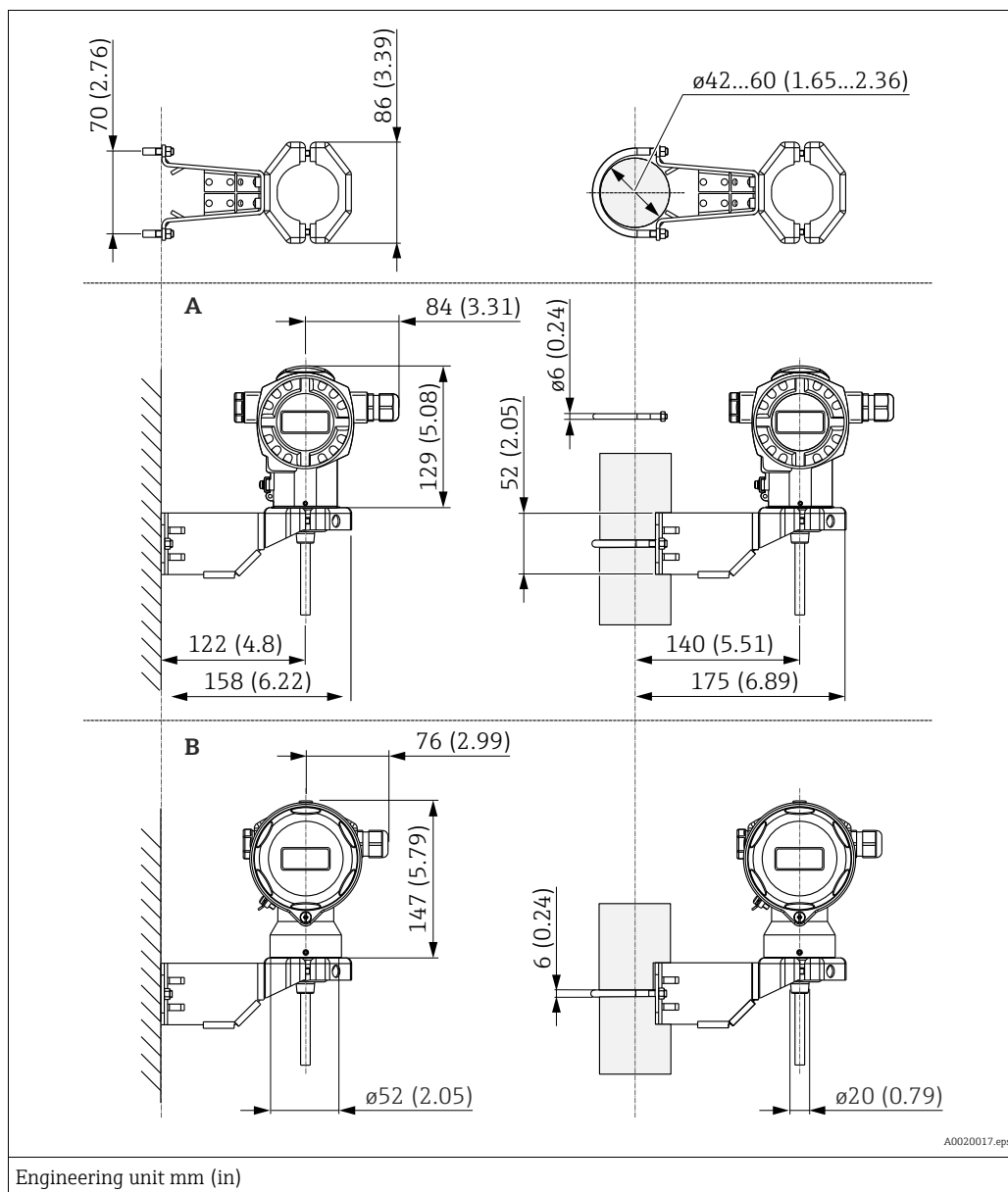

Position	Designation	Weight (kg (lbs))		Option <sup>1)</sup>
		Housing (T14 or T17)	Mounting bracket	
A	Dimensions with T14 housing, optional display on the side	→ 30 ff	0.5 (1.10)	U
B	Dimensions with T17 housing, optional display on the side			

1) Product Configurator, "Additional options 2:" ordering feature

Can also be ordered as a separate accessory (part no.: 71102216).

**Materials not in contact with process**     **Housing**

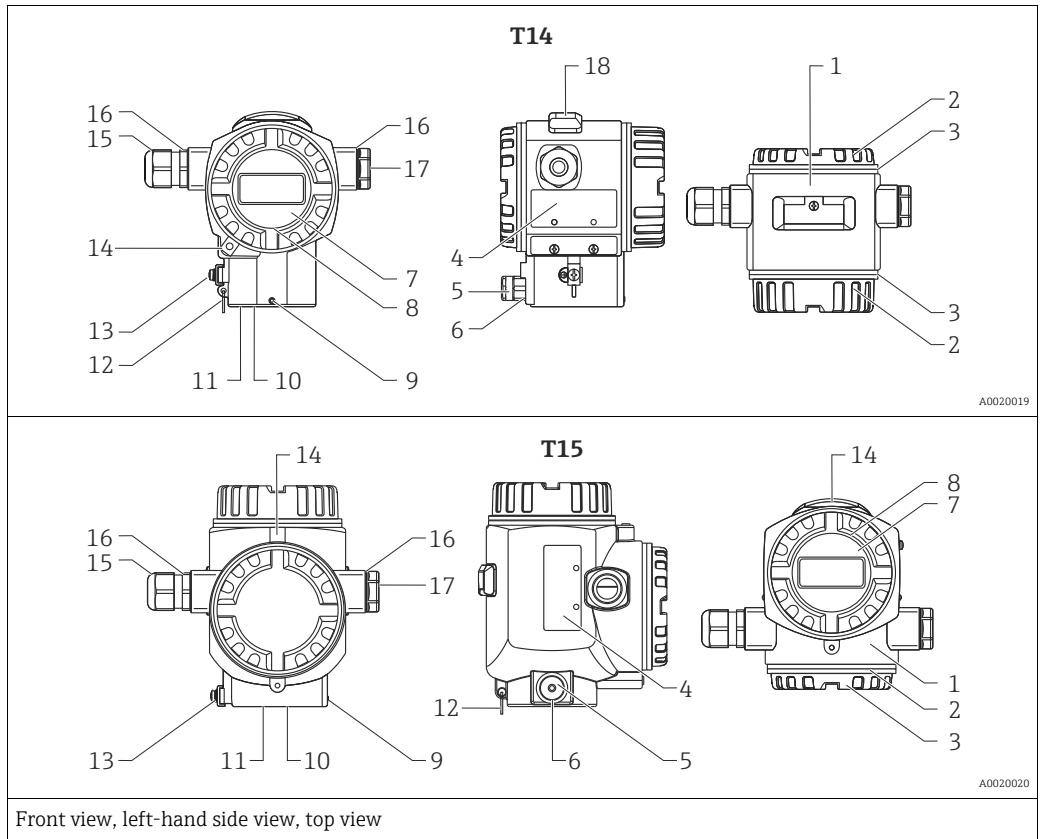

Item number	Component part	Material
1	T14 and T15 housing, RAL 5012 (blue)	<ul style="list-style-type: none"> <li>■ Die-cast aluminum with protective powder-coating on polyester base</li> <li>■ Coating on thread: Heat-curing lubricant varnish</li> </ul>
2	Cover, RAL 7035 (gray)	Die-cast aluminum with protective powder-coating on polyester base
3	Cover seal	EPDM
4	Nameplates	AISI 316L (1.4404)
5	Pressure compensation filter	AISI 316L (1.4404) and PBT-FR
6	Pressure compensation filter, O-ring	VMQ or EPDM
7	Sight glass	Mineral glass
8	Sight glass seal	Silicone (VMQ)
9	Screw	A4
10	Sealing ring	EPDM
11	Snap ring	PA66-GF25
12	Snap ring for nameplates	AISI 304 (1.4301)/ AISI 316 (1.4401)
13	External ground terminal	AISI 304 (1.4301)
14	Cover clamp	Clamp AISI 316L (1.4435), screw A4
15	Cable entry	Polyamide (PA) or CuZn nickel-plated
16	Seal of cable entry and blind plug	Silicone (VMQ)

Item number	Component part	Material
17	Blind plug	PBT-GF30 FR, for dust ignition-proof: AISI 316L (1.4435)
18	External operation (keys and key cover), RAL 7035 (gray)	Polycarbonate PC-FR, screw A4

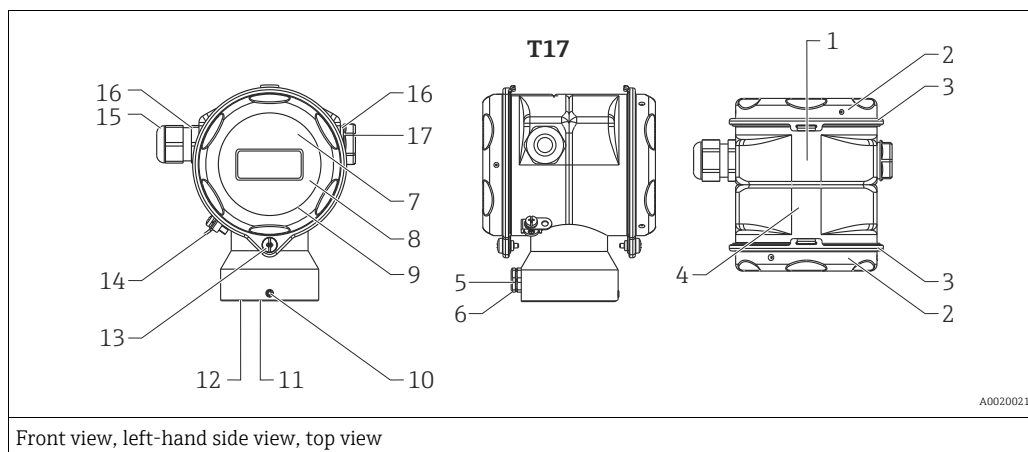

Front view, left-hand side view, top view

Item number	Component part	Material
1	T17 housing	AISI 316L (1.4404)
2	Cover	
3	Cover seal	EPDM
4	Nameplates	Lasered
5	Pressure compensation filter	AISI 316L (1.4404) and PBT-FR
6	Pressure compensation filter, O-ring	VMQ or EPDM
7	Sight glass for non-hazardous area, ATEX Ex ia, NEPSI Zone 0/1 Ex ia, IECEx Zone 0/1 Ex ia, FM NI, FM IS, CSA IS	Polycarbonate (PC)
8	Sight glass for ATEX 1/2 D, ATEX 1/3 D, ATEX 1 GD, ATEX 1/2 GD, ATEX 3 G, FM DIP, CSA dust ignition-proof	Mineral glass
9	Sight glass seal	EPDM
10	Screw	A2-70
11	Sealing ring	EPDM
12	Snap ring	PA6
13	Screw	A4-50
14	External ground terminal	AISI 304 (1.4301)
15	Cable entry	Polyamide PA, for dust ignition-proof: CuZn nickel-plated
16	Seal of cable entry and blind plug	Silicone (VMQ)
17	Blind plug	PBT-GF30 FR, for dust ignition-proof: AISI 316L (1.4435)

**Connecting parts**

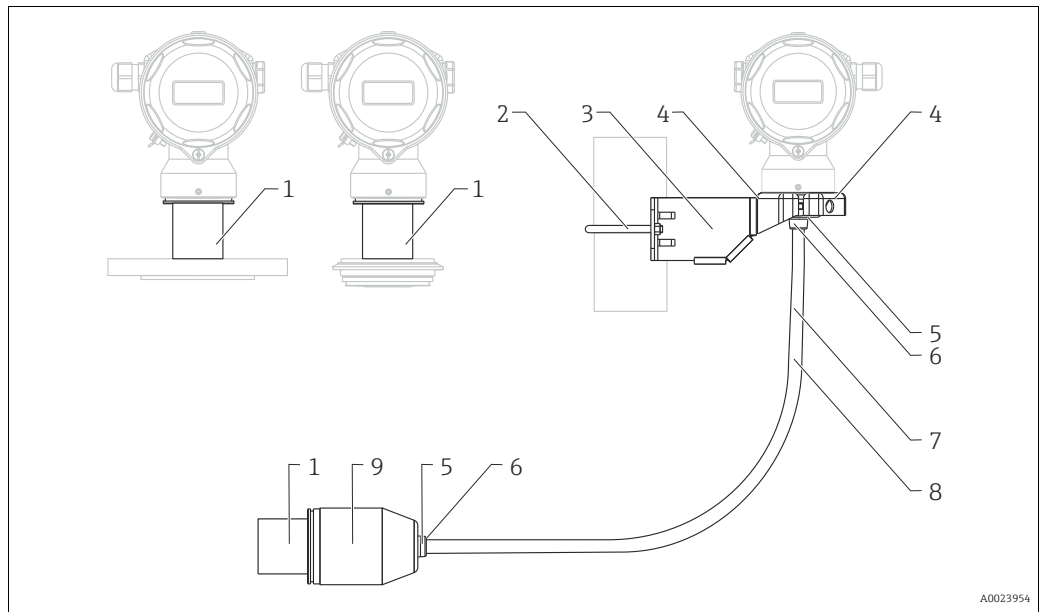

Item number	Component part	Material
1	Connection between the housing and process connection	AISI 316L (1.4404)
2	Mounting bracket	Bracket AISI 316L (1.4404)
3		Screw and nuts A4-70
4		Half-shells: AISI 316L (1.4404)
5	Seal for cable from Separate housing	EPDM
6	Gland for cable from separate housing	AISI 316L (1.4404)
7	PE cable for separate housing	abrasion-proof cable with strain-relief Dynema members; shielded using aluminum-coated foil; insulated with polyethylene (PE-LD), black; copper wires, twisted, UV-resistant
8	FEP cable for separate housing	abrasion-proof cable; shielded using galvanized steel wire netting; insulated with fluorinated ethylene propylene (FEP), black; copper wires, twisted, UV-resistant
9	Process connection adapter for separate housing	AISI 316L (1.4404)

**Fill fluid**

Designation	Option <sup>1)</sup>
Synthetic oil polyalphaolefin FDA 21 CFR 178.3570, NSF H1	C
Inert oil	F
Inert oil, cleaned for silicone-free service	L

1) Product Configurator, "Fill fluid" ordering feature

**Materials in contact with process****Process connections**

Process-wetted device components are listed in the "Mechanical construction" (→  30) and "Ordering information" (→  53) sections.

**Process isolating diaphragm**

Designation	Option <sup>1)</sup>
Alloy C276 (2.4819), Ø 35.8 mm (1.41 in)	2
Alloy C276 (2.4819), Ø 35.8 mm (1.41 in), with gold-rhodium coating	6

1) Product Configurator, "Material of process isolating diaphragm; seal:"

**TSE Certificate of Suitability (Transmissible Spongiform Encephalopathy)**

The following applies to all process wetted device components:

- They do not contain any materials derived from animals.
- No additives or operating materials derived from animals are used in production or processing.



Process-wetted device components are listed in the "Mechanical construction" section (→  30 ff).

## Operability

### Operating concept

#### Operator-oriented menu structure for user-specific tasks

- Commissioning
- Operation
- Diagnosis

#### Quick and safe commissioning

Guided menus for applications

#### Reliable operation

- Local operation possible in several languages
- Standardized operation at the device and in the operating tools
- Parameters relating to measured values can be locked/unlocked using the device's write protection switch, using the device software or via remote control

#### Efficient diagnostics increase measurement availability

- Remedial measures are integrated in plain text
- Diverse simulation options

### Local operation

Function	External operation (operating keys, optional, not T17 housing)	Internal operation (electronic insert)	Display (optional)
Position adjustment (zero point correction)	✓	✓	✓
Setting lower-range value and upper-range value - reference pressure present at the device	✓ (HART only)	✓ (HART only)	✓
Device reset	✓	✓	✓
Locking and unlocking parameters relevant to the measured value	–	✓	✓
Value acceptance indicated by green LED	✓	✓	✓
Switching damping on and off	–	✓ (HART and PA only)	✓
Configuring bus address (PA)	–	✓	✓
Switching simulation mode on and off (FOUNDATION Fieldbus)	–	✓	✓

#### Operating the device using onsite display (optional)

A 4-line liquid crystal display (LCD) is used for display and operation. The onsite display shows measured values, dialog text as well as fault and notice messages in plain text, thereby supporting the user in every stage of operation. The device display can be turned in 90° steps.

Depending on the installation position of the device, this makes it easy to operate the device and read the measured value.

Functions:

- 8-digit measured value display incl. sign and decimal point, bar graph for
  - 4 to 20 mA HART as current display
  - PROFIBUS PA as graphic display of the standardized value of the AI block
  - FOUNDATION Fieldbus as graphic display of the transducer output
- Simple and complete menu guidance thanks to separation of the parameters into several levels and groups.
- Menu guidance in up to 8 languages
- Each parameter is given a 3-digit ID number for easy navigation.

- Option for configuring the display according to individual requirements and preferences, such as language, alternating display, display of other measured values such as sensor temperature, contrast setting.
- Comprehensive diagnostic functions (fault and warning message, peak-hold indicators, etc.).
- Rapid and safe commissioning with the Quick Setup menus.

#### Overview

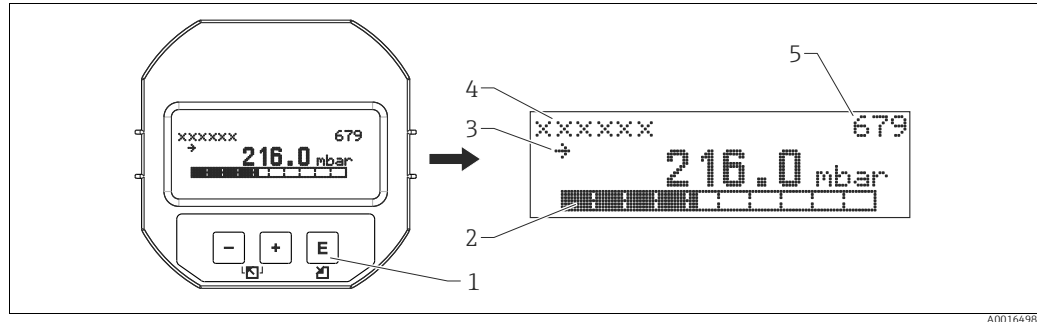

- 1 Operating keys
- 2 Bar graph
- 3 Symbol
- 4 Header line
- 5 Parameter identification number

#### Ordering information :

Product Configurator "Output, operation" ordering feature

#### Operating keys on the exterior of the device

With the aluminum housing (T14 and T15), the operating keys are located either outside of the housing, under the protection cap or inside on the electronic insert. With the T17 housing (stainless steel), the operating keys are located inside the housing on the electronic insert.

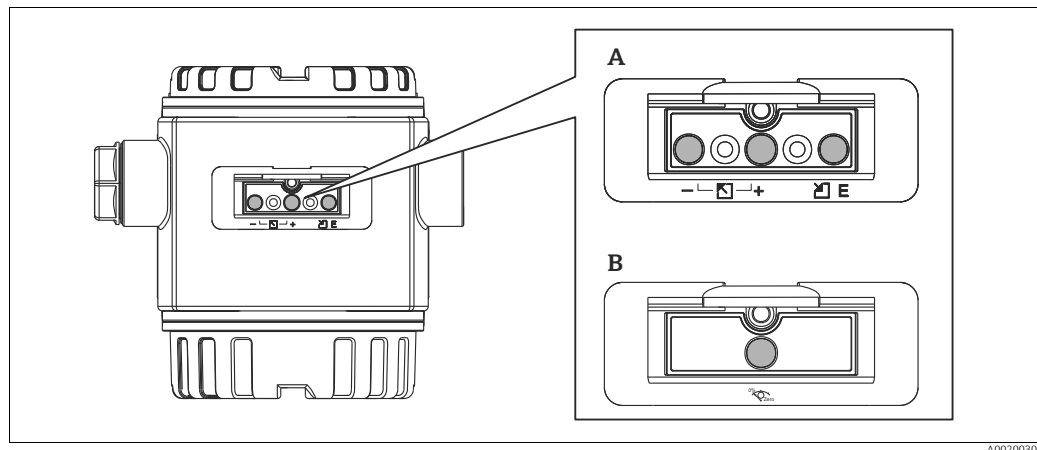

- A 4 to 20 mA HART
- B PROFIBUS PA and FOUNDATION Fieldbus

The operating keys located externally on the device work on the Hall sensor principle. As a result, no additional openings are required in the device. This guarantees:

- Complete protection against environmental influences such as moisture and contamination.
- Simple operation without any tools.
- No wear.

#### Ordering information :

Product Configurator "Output, operation" ordering feature

Operating keys and elements located internally on the electronic insert

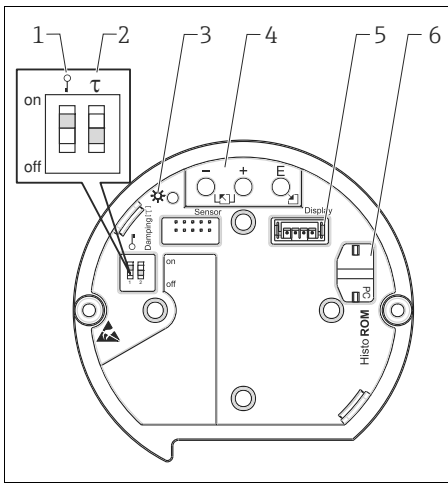

A0020031

Electronic insert HART

- 1 DIP-switch for locking/unlocking parameters relevant to the measured values
- 2 DIP-switch for damping on/off
- 3 Green LED to indicate value being accepted
- 4 Operating keys
- 5 Slot for optional display
- 6 Slot for optional HistoROM®/M-DAT

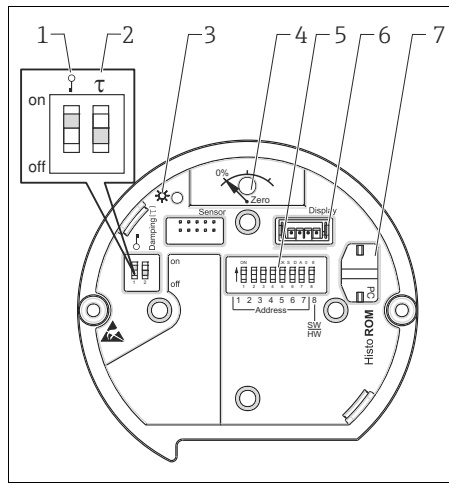

A0020032

Electronic insert PROFIBUS PA

- 1 DIP-switch for locking/unlocking parameters relevant to the measured values
- 2 DIP-switch for damping on/off
- 3 Green LED to indicate value being accepted
- 4 Key for position adjustment and device reset
- 5 DIP-switch for bus address
- 6 Slot for optional display
- 7 Slot for optional HistoROM®/M-DAT

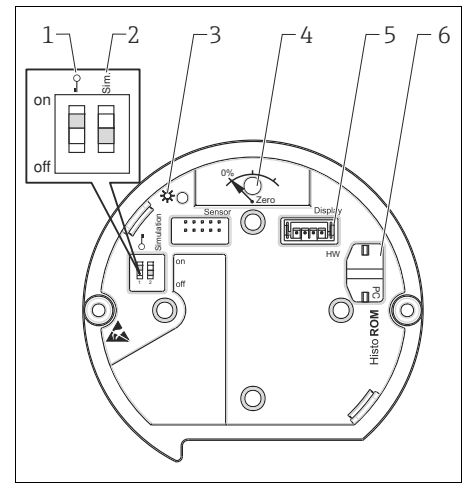

A0020033

Electronic insert FOUNDATION Fieldbus

- 1 DIP-switch for locking/unlocking parameters relevant to the measured values
- 2 DIP-switch for simulation mode on/off
- 3 Green LED to indicate value being accepted
- 4 Key for position adjustment and device reset
- 5 Slot for optional display
- 6 Slot for optional HistoROM®/M-DAT

Ordering information :

Product Configurator "Output, operation" ordering feature

Remote operation

All software parameters are accessible depending on the position of the write protection switch on the device.

Hardware and software for remote operation	HART	PROFIBUS PA	FOUNDATION Fieldbus
FieldCare → 47 ff	✓ <sup>1)</sup>	✓ <sup>2)</sup>	✓
FieldXpert SFX100 → 48 ff	✓	—	✓
NI-FBUS Configurator → 48 ff	—	—	✓
HistoROM®/M-DAT → 48 ff	✓	✓	✓

1) Commubox FXA195 required → 48 ff

2) Profiboard or Proficard required → 48 ff

FieldCare

FieldCare is an Endress+Hauser asset management tool based on FDT technology. With FieldCare, you can configure all Endress+Hauser devices as well as devices from other manufacturers that support the FDT standard.

FieldCare supports the following functions:

- Configuration of transmitters in offline and online mode
- Loading and saving device data (upload/download)
- HistoROM®/M-DAT analysis
- Documentation of the measuring point

Connection options:

- HART via Commubox FXA195 and the USB port on a computer
- PROFIBUS PA via segment coupler and PROFIBUS interface card
- Service interface with Commubox FXA291 and ToF adapter FXA291 (USB).

For further information please contact your local Endress+Hauser Sales Center.

**Field Xpert SFX100**

Field Xpert is an industrial PDA with integrated 3.5" touchscreen from Endress+Hauser based on Windows Mobile. It offers wireless communication via the optional VIATOR Bluetooth modem or via WiFi and Endress+Hauser's Fieldgate FXA520. Field Xpert also works as a stand-alone device for asset management applications. For details, refer to BA00060S/04/EN.

**Commubox FXA195**

For intrinsically safe HART communication with FieldCare via the USB interface. For details refer to TI00404F/00/EN.

**Commubox FXA291**

The Commubox FXA291 connects Endress+Hauser field devices with a CDI interface (=Endress+Hauser Common Data Interface) to the USB interface of a personal computer or a notebook. For details refer to TI00405C/07/EN.



For the following Endress+Hauser devices you need the "ToF adapter FXA291" as an additional accessory:

- Cerabar S PMC71, PMP7x
- Deltabar S PMD7x, FMD7x
- Deltapilot S FMB70

**ToF adapter FXA291**

The ToF adapter FXA291 connects the Commubox FXA291 with devices of the ToF platform, pressure equipment and Gammapilot via the USB interface of a personal computer or a notebook. For details refer to KA00271F.

**Profiboard**

For connecting a PC to PROFIBUS.

**Proficard**

For connecting a laptop to PROFIBUS

**FF configuration program**

FF configuration program, such as NI-FBUS Configurator, to

- connect devices with "FOUNDATION Fieldbus signal" into an FF network
- set FF-specific parameters

Remote operation via:

- Operation with NI-FBUS Configurator:
  - The NI-FBUS Configurator is an easy-to-use graphical environment for creating linkages, loops, and a schedule based on the fieldbus concepts.
  - You can use the NI-FBUS Configurator to configure a fieldbus network as follows:
    - Set block and device tags
    - Set device addresses
    - Create and edit function block control strategies (function block applications)
    - Configure vendor-defined function and transducer blocks
    - Create and edit schedules
    - Read and write to function block control strategies (function block applications)
    - Invoke Device Description (DD) methods
    - Display DD menus
    - Download a configuration
    - Verify a configuration and compare it to a saved configuration
    - Monitor a downloaded configuration
    - Replace a virtual device by a real device
    - Save and print a configuration

**HistoROM®/M-DAT (optional)**

HistoROM®/M-DAT is a memory module which can be attached to every electronic insert. The HistoROM®/M-DAT can be retrofitted at any stage (order number: 52027785).

*Your benefits*

- Quick and safe commissioning of the same measuring points by copying the configuration data of one transmitter to another transmitter.
- Reliable process monitoring thanks to cyclical recording of pressure and sensor temperature measured values.
- Simple diagnosis by recording diverse events such as alarms, configuration changes, counters for measuring range undershoot and overshoot for pressure and temperature as well as user limit overshoot and undershoot for pressure and temperature etc.
- Analysis and graphic evaluation of the events and process parameters via software (contained in scope of supply).

A CD with an Endress+Hauser operating program is also included in the scope of delivery.

You can copy data from one transmitter to another transmitter when operating a FOUNDATION Fieldbus device via an FF configuration program. You need the Endress+Hauser FieldCare operating program and the Commubox FXA291 service interface and the ToF adapter FXA291 to be able to access the data and events saved in the HistoROM®/M-DAT.

## Ordering information :

Product Configurator, "Additional options:" ordering feature, option "N" or

Product Configurator, "Application package:" ordering feature, option "EN" or as a separate accessory (part no.: 52027785).



For further information please contact your local Endress+Hauser Sales Center.





**System integration**

The device can be given a tag name (max. 8 alphanumeric characters)

Designation	Option <sup>1)</sup>
Tagging (TAG), see additional spec.	Z1
Bus address, see additional spec.	Z2

1) Product configurator "Marking" ordering feature

## Certificates and approvals

<b>CE mark</b>	<p>The device meets the legal requirements of the relevant EC directive. Endress+Hauser confirms that the device has been successfully tested by applying the CE mark.</p>
<b>Ex approvals</b>	<ul style="list-style-type: none"> <li>▪ ATEX</li> <li>▪ FM</li> <li>▪ CSA</li> <li>▪ NEPSI</li> <li>▪ IECEX</li> <li>▪ GOST on request</li> <li>▪ TIIS</li> </ul> <p>All explosion protection data are given in separate documentation which is available upon request. The Ex documentation is supplied as standard with all devices approved for use in explosion hazardous areas. →  57 ff, "Safety Instructions" and "Installation/ Control Drawings" sections.</p>
<b>Suitability for hygienic processes</b>	<ul style="list-style-type: none"> <li>▪ Materials in contact with food comply with Regulation (EC) No. 1935/2004.</li> <li>▪ The Deltapilot S is suitable for use in hygienic processes. Overview of suitable process connections from →  30. Many versions meet the requirements of 3A-Sanitary Standard No. 74 and are certified by the EHEDG. Suitable fittings and seals must be used to ensure hygiene-compliant design according to the specifications of 3A and EHEDG.</li> </ul>
<div style="display: flex; justify-content: space-around; align-items: center;">   </div> <div style="display: flex; justify-content: space-between; margin-top: 5px;"> <span data-bbox="866 1267 919 1283">A0020028</span> <span data-bbox="1385 1267 1437 1283">A0020029</span> </div>	
<p> The gap-free connections can be cleaned without residue using the usual cleaning methods.</p>	
<b>Functional safety SIL/ IEC 61508 Declaration of Conformity (optional)</b>	<p>The Deltapilot S devices with 4 to 20 mA output signal have been developed to IEC 61508 standard. These devices can be used to monitor the process level and pressure up to SIL 3. For a detailed description of the safety functions with Deltapilot S, settings and characteristic quantities for functional safety, please refer to the "Functional Safety Manual - Deltapilot S" SD002.13P/00.</p> <p>Ordering information : Product Configurator, "Additional options 1" ordering feature, option "1" and "Additional options 2" ordering feature, option "E".</p>
<b>Overfill protection</b>	<p>WHG (see document ZE00266P).</p> <p>Ordering information : Product Configurator, "Approval" ordering feature, option "F".</p>
<b>CRN approvals</b>	<p>Some device versions have CRN approval. For a CRN-approved device, a CRN-approved process connection must be ordered with a CSA approval. These devices are fitted with a separate plate bearing the registration number CRN OF1987.7C.</p> <p>Ordering information : Product Configurator, "Process connection; Material" ordering feature and Product Configurator, "Approval" ordering feature</p>

<b>Standards and guidelines</b>	<p>DIN EN 60770 (IEC 60770): Transmitters for use in industrial-process control systems Part 1: Methods for inspection and routine testing</p> <p>DIN 16086: Electrical pressure measuring instruments, pressure sensors, pressure transmitters, pressure measuring instruments, concepts, specifications on data sheets</p> <p>EN 61326-X: EMC product family standard for electrical equipment for measurement, control and laboratory use.</p>
---------------------------------	---

<b>Pressure Equipment Directive (PED)</b>	The Deltapilot S device corresponds to Article 3 (3) of the EC directive 97/23/EC (Pressure Equipment Directive) and has been designed and manufactured according to good engineering practice.
---	---

<b>Marine approval</b>	<p>GL (German Lloyd)</p> <p>Ordering information : Product Configurator, "Additional options" ordering feature, option "S".</p>
------------------------	---

<b>Drinking water approval</b>	<p>NSF 61 approval</p> <p>Ordering information : Product Configurator, "Additional options" ordering feature, option "F".</p>
--------------------------------	---

<b>Classification of process sealing between electrical systems and (flammable or combustible) process fluids in accordance with ANSI/ISA 12.27.01</b>	<p>Endress+Hauser devices are designed in accordance with ANSI/ISA 12.27.01. allowing the user to waive the use and save the cost of installing external secondary process seals in the conduit as required by the process sealing sections of ANSI/NFPA 70 (NEC) and CSA 22.1 (CEC). These instruments comply with the North American installation practice and provide a very safe and cost-saving installation for pressurized applications with hazardous fluids. Please refer to the following table for the seal class assigned (single seal or dual seal):</p>
--	---

Device	Approval	Single seal MWP
FMB70	CSA C/ US IS	10 bar (150 psi)

Further information can be found in the control drawings of the relevant devices.

<b>Inspection certificate</b>	<b>Designation</b>	<b>Option</b>
	EN10204-3.1 material (wetted) inspection certificate	B <sup>1)</sup>
	EN10204-3.1 individual testing, inspection certificate	3 <sup>1)</sup>
	EN10204-3.1 pressure test, inspection certificate	4 <sup>1)</sup>
	EN10204-3.1 AD2000 pressure-bearing inspection certificate	5 <sup>1)</sup>
	EN10204-3.1 wetted material +Ra, Ra= surface roughness, dimension test, inspection certificate	6 <sup>1)</sup>
	EN10204-3.1 helium leak test, inspection certificate	7 <sup>1)</sup>
	EN10204-3.1 measurement Delta ferrite content, inspection certificate	8 <sup>1)</sup>
	3.1 Material documentation, wetted metal parts, EN10204-3.1 inspection certificate	YES <sup>2)</sup>

1) Product Configurator, "Additional options 1" and "Additional options 2" ordering feature

2) Product Configurator, "Test, certificate" ordering feature

**Calibration**

<b>Designation</b>	<b>Option <sup>1)</sup></b>
Sensor range; %	A
Customer-specific; see additional specification	B
Factory calibration certificate, 5-point; see additional specification	C
DKD/DAkkS certificate; see additional specification	D
Customized pressure; see additional specification	E
Customized level; see additional specification	F
Customized pressure + 5-point factory calibration certificate; see additional specification	H
Customized level + 5-point factory calibration certificate; see additional specification	I
Platinum; see additional specification	K
Platinum + factory calibration certificate 5-point; see additional specification	L
Platinum + DKD/DAkkS certificate; see additional specification	M
Sensor range; mbar/bar	1
Sensor range; kPa/MPa	2
Sensor range; mmH <sub>2</sub> O/mH <sub>2</sub> O	3
Sensor range; inH <sub>2</sub> O/ftH <sub>2</sub> O	4
Sensor range; psi	6

1) Product Configurator, "Calibration; Unit" ordering feature

**Certificate of Compliance  
ASME BPE**

Ordering information :  
Product Configurator, "Additional options 1" and "Additional options 2" ordering feature, option "L".

## Ordering information

Detailed ordering information is available from the following sources:

- In the Product Configurator on the Endress+Hauser website: [www.endress.com](http://www.endress.com) → Select country → Products → Select product → Product page function: Configure this product
- From your Endress+Hauser Sales Center: [www.endress.com/worldwide](http://www.endress.com/worldwide)



### Product Configurator - the tool for individual product configuration

- Up-to-the-minute configuration data
- Depending on the device: Direct input of measuring point-specific information such as measuring range or operating language
- Automatic verification of exclusion criteria
- Automatic creation of the order code and its breakdown in PDF or Excel output format
- Ability to order directly in the Endress+Hauser Online Shop

## Configuration data sheet

### Pressure

The following configuration data sheet must be completed and included with the order if the option "E" or "H" has been selected in the Product Configurator, "Calibration; Unit" ordering feature.

Pressure unit				
<input type="checkbox"/> mbar	<input type="checkbox"/> mmH <sub>2</sub> O <sup>1)</sup>	<input type="checkbox"/> mmHg <sup>2)</sup>	<input type="checkbox"/> Pascal	<input type="checkbox"/> torr
<input type="checkbox"/> bar	<input type="checkbox"/> mH <sub>2</sub> O <sup>1)</sup>	<input type="checkbox"/> inHg <sup>2)</sup>	<input type="checkbox"/> hPa	
	<input type="checkbox"/> ftH <sub>2</sub> O <sup>1)</sup>		<input type="checkbox"/> kPa	<input type="checkbox"/> g/cm <sup>2</sup>
<input type="checkbox"/> psi	<input type="checkbox"/> inH <sub>2</sub> O <sup>1)</sup>	<input type="checkbox"/> gf/cm <sup>2</sup>	<input type="checkbox"/> MPa	<input type="checkbox"/> kg/cm <sup>2</sup>
		<input type="checkbox"/> kgf/cm <sup>2</sup>		<input type="checkbox"/> lb/ft <sup>2</sup>
				<input type="checkbox"/> atm
<sup>1)</sup> The conversion factor of the pressure unit refers to a reference temperature of 4 °C (39.2 °F). <sup>2)</sup> The conversion factor of the pressure units refers to a reference temperature of 0 °C (32 °F).				
Calibration range / Output				
Lower range value (LRV):	_____	[Pressure unit]		
Upper range value (URV):	_____	[Pressure unit]		
Display				
Display the contents of the main line <sup>1)</sup>				
<input type="checkbox"/> Primary value [PV] (default)				
<input type="checkbox"/> Primary value [%]				
<input type="checkbox"/> Pressure				
<input type="checkbox"/> Current [mA] (HART only)				
<input type="checkbox"/> Temperature				
<input type="checkbox"/> Error number				
<input type="checkbox"/> Alternating display				
<sup>1)</sup> Depending on sensor and communication variant				
Damping				
Damping	_____	sec (default 2 sec)		

Smallest span (factory calibration) → 10

**Level**

The following configuration data sheet must be completed and included with the order if the option "F" or "I" has been selected in the Product Configurator, "Calibration; Unit" ordering feature.

Pressure unit					Output unit (scaled unit)				
<input type="checkbox"/> mbar	<input type="checkbox"/> mmH <sub>2</sub> O <sup>1)</sup>	<input type="checkbox"/> mmHg <sup>2)</sup>	<input type="checkbox"/> Pascal	<input type="checkbox"/> torr	Mass	Lengths	Volume	Volume	Percent
<input type="checkbox"/> bar	<input type="checkbox"/> mH <sub>2</sub> O <sup>1)</sup>	<input type="checkbox"/> inHg <sup>2)</sup>	<input type="checkbox"/> hPa	<input type="checkbox"/> g/cm <sup>2</sup>	<input type="checkbox"/> kg	<input type="checkbox"/> m	<input type="checkbox"/> l	<input type="checkbox"/> USgal	<input type="checkbox"/> %
<input type="checkbox"/> psi	<input type="checkbox"/> ftH <sub>2</sub> O <sup>1)</sup>	<input type="checkbox"/> gf/cm <sup>2</sup>	<input type="checkbox"/> kPa	<input type="checkbox"/> kg/cm <sup>2</sup>	<input type="checkbox"/> t	<input type="checkbox"/> dm	<input type="checkbox"/> hl	<input type="checkbox"/> impgal	
	<input type="checkbox"/> inH <sub>2</sub> O <sup>1)</sup>	<input type="checkbox"/> kgf/cm <sup>2</sup>	<input type="checkbox"/> MPa	<input type="checkbox"/> lb/ft <sup>2</sup>	<input type="checkbox"/> lb	<input type="checkbox"/> cm	<input type="checkbox"/> m <sup>3</sup>	<input type="checkbox"/> USbbIPETR	
		<input type="checkbox"/> kgf/cm <sup>2</sup>		<input type="checkbox"/> atm		<input type="checkbox"/> mm	<input type="checkbox"/> ft <sup>3</sup>		
						<input type="checkbox"/> ft			
						<input type="checkbox"/> inch			

<p>Empty pressure [a]: Low pressure value (empty) _____ [Pressure unit]</p> <p>Full pressure [b]: High pressure value (full) _____ [Pressure unit]</p>	<p>Empty calibration [a]: Low level value (empty) _____ [Scaled unit]</p> <p>Full calibration [b]: High level value (full) _____ [Scaled unit]</p>
--	--

**Example**

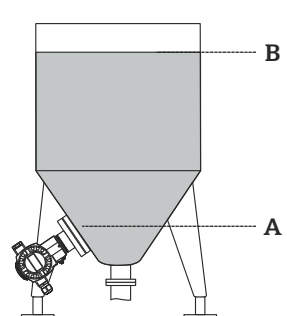

A

B

A    0 mbar / 0m

B    300 mbar (4.5psi) / 3 m (9.8 ft).

A0020042

**Display**

Display the contents of the main line <sup>1)</sup>

- Primary value [PV] (default)
- Primary value [%]
- Pressure
- Current [mA] (HART only)
- Temperature
- Level before lin.
- Tank content
- Error number
- Alternating display

<sup>1)</sup> Depending on sensor and communication variant

  

**Damping**

Damping    \_\_\_\_\_ sec (default 2 sec)

## Accessories

---

<b>HistoROM®/M-DAT</b>	<p>HistoROM®/M-DAT is a memory module which can be attached to every electronic insert.</p> <p>Ordering information: Product Configurator, "Additional options 1:" ordering feature, option "N" or as a separate accessory (part no.: 52027785).</p>
<b>Wall and pipe-mounting</b>	<p>Endress+Hauser offers a mounting bracket for installing the device on pipes or walls.</p> <p>Ordering information : Product Configurator, "Additional options" ordering feature, option "U" or Product Configurator "Enclosed accessories" ordering feature, option "PA" or as a separate accessory (part no.: 71102216).</p> <p>Dimensions →  40.</p>
<b>Welding flanges</b>	<p>For details refer to TI00426F/00/EN "Weld-in adapter and flanges".</p>
<b>Weld-in adapter for universal process adapter</b>	<p>For details refer to TI00426F/00/EN "Weld-in adapter and flanges".</p>
<b>Weld-in adapter for ISO G ½ thread</b>	<p>For details refer to TI00426F/00/EN "Weld-in adapter and flanges".</p>

**Adapter Uni**

The following adapters can be used to create a connection between the customer's process connection and the Deltapilot S with a universal adapter:

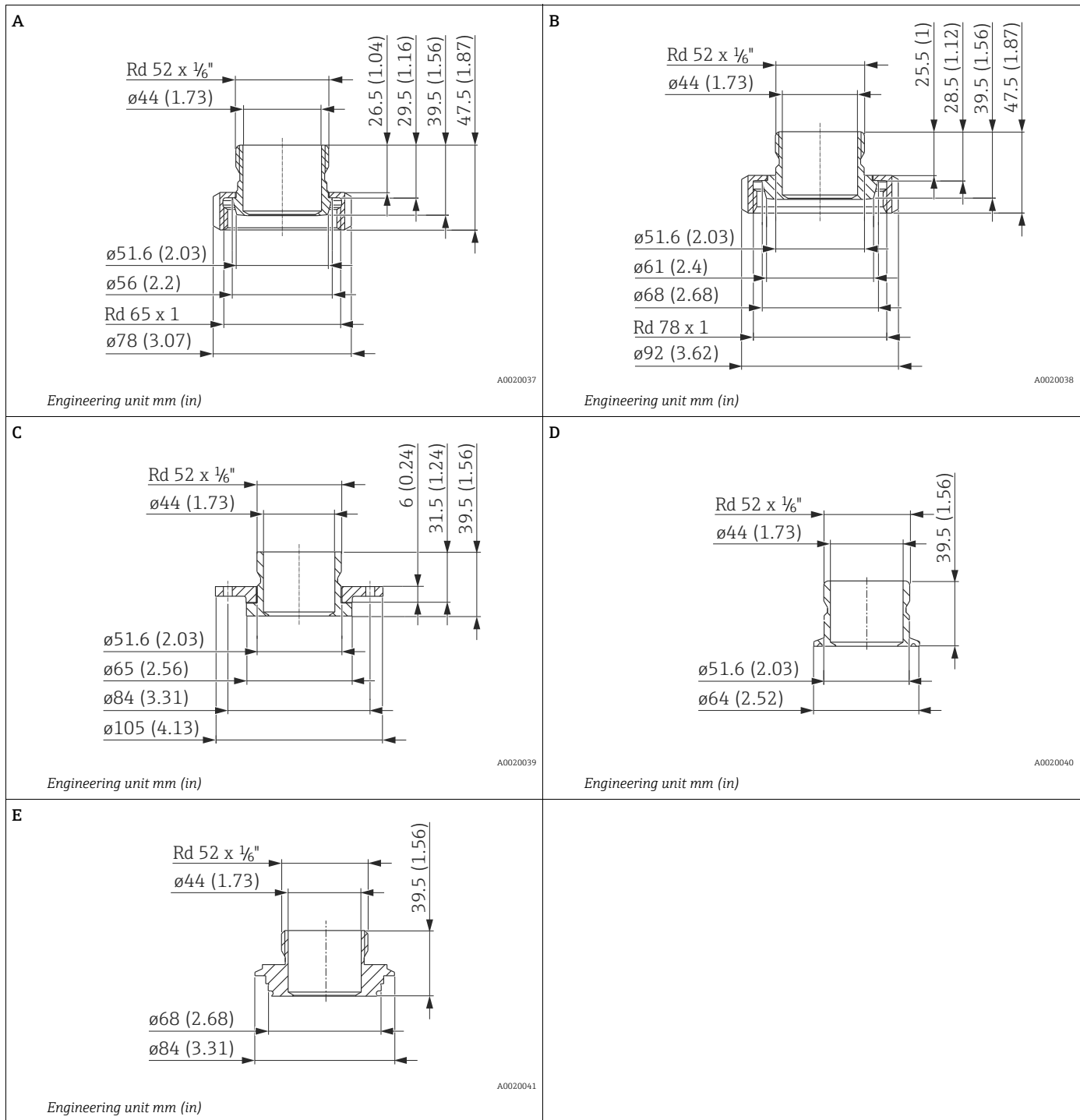

Position	Designation	Material	Weight kg (lbs)	Order number	Order number with 3.1 inspection certificate
A	DIN 11851 DN 40	AISI 316L (1.4435)	0.2 (0.44)	71114172	71114178
B	DIN 11851 DN 50		0.3 (0.66)	71114173	71114205
C	DRD DN50		0.6 (1.32)	71114174	71114206
D	Clamp 2"		0.2 (0.44)	71114176	71114207
E	Varivent		0.5 (1.1)	71114177	71114208

## Additional documentation

<b>Field of Activities</b>	Pressure measurement, powerful instruments for process pressure, differential pressure, level and flow: FA00004P/00/EN
<b>Technical Information</b>	<ul style="list-style-type: none"> <li>■ EMC test procedures: TI00241F/00/EN</li> <li>■ Technical Information for Deltabar S: TI00382P/00/EN</li> <li>■ Technical Information for Cerabar S: TI00383P/00/EN</li> </ul>
<b>Operating Instructions</b>	<p>4 to 20 mA HART:</p> <ul style="list-style-type: none"> <li>■ Deltapilot S: BA00332P/00/EN</li> <li>■ Description of device functions Cerabar S/Deltabar S/Deltapilot S: BA00274P/00/EN</li> </ul> <p>PROFIBUS PA:</p> <ul style="list-style-type: none"> <li>■ Deltapilot S: BA00356P/00/EN</li> <li>■ Description of device functions Cerabar S/Deltabar S/Deltapilot S: BA00296P/00/EN</li> </ul> <p>FOUNDATION Fieldbus:</p> <ul style="list-style-type: none"> <li>■ Deltapilot S: BA00372P/00/EN</li> <li>■ Description of device functions Cerabar S/Deltabar S/Deltapilot S: BA00303P/00/EN</li> </ul>
<b>Brief Operating Instructions</b>	<ul style="list-style-type: none"> <li>■ 4 to 20 mA HART, Deltapilot S: KA01020P/00/EN</li> <li>■ PROFIBUS PA, Deltapilot S: KA01023P/00/EN</li> <li>■ FOUNDATION Fieldbus, Deltapilot S: KA01026P/00/EN</li> </ul>
<b>Functional safety manual (SIL)</b>	Deltapilot S (4 to 20 mA): SD00213P/00/EN

### Safety Instructions

Directive	Electronic insert	Documentation	Option <sup>1)</sup>
ATEX II 1/2 G Ex ia IIC T6	- 4 to 20 mA HART, PROFIBUS PA, FOUNDATION Fieldbus	- XA00283P	1
ATEX II 1/2 G Ex ia IIC T6, WHG	- 4 to 20 mA HART	- XA00283P and ZE00266P	6
ATEX II 1/2 D	- 4 to 20 mA HART, PROFIBUS PA, FOUNDATION Fieldbus	- XA00284P	2
ATEX II 1/3 D	- 4 to 20 mA HART, PROFIBUS PA, FOUNDATION Fieldbus	- XA00285P	4
ATEX II 1 GD Ex ia IIC T6	- 4 to 20 mA HART, PROFIBUS PA, FOUNDATION Fieldbus	- XA00287P	8
ATEX II 1/2 GD Ex ia IIC T6	- 4 to 20 mA HART, PROFIBUS PA, FOUNDATION Fieldbus	- XA00286P	3
ATEX II 3 G Ex nA II T6	- 4 to 20 mA HART, PROFIBUS PA, FOUNDATION Fieldbus	- XA00288P	7
ATEX II Ex ia + FM IS + CSA IS ATEX II 1/2G Ex ia IIC T6+ FM/CSA IS CL,I,II,III Div.1 Gr.A-G	- 4 to 20 mA HART, PROFIBUS PA, FOUNDATION Fieldbus	- XA00252P	E

1) Product Configurator, "Approval" ordering feature

Directive	Electronic insert	Documentation	Option <sup>1)</sup>
IECEx Zone 0/1 Ex ia IIC T6	- 4 to 20 mA HART, PROFIBUS PA, FOUNDATION Fieldbus	- XB00010P	I

1) Product Configurator, "Approval" ordering feature

Directive	Electronic insert	Documentation	Option <sup>1)</sup>
NEPSI Ex ia IIC T4/T6	- 4 to 20 mA HART, PROFIBUS PA, FOUNDATION Fieldbus	- XA00435P	H

1) Product Configurator, "Approval" ordering feature

Directive	Electronic insert	Documentation	Option <sup>1)</sup>
TIIS Ex ia IIC T4	4 to 20 mA HART		K

1) Product Configurator, "Approval" ordering feature

Directive	Electronic insert	Documentation	Option <sup>1)</sup>
INMETRO Ex ia IIC T6 Ga/Gb	- 4...20 mA HART, PROFIBUS PA, FOUNDATION Fieldbus	- XA01320P/00	J
INMETRO Ex ta IIIC Da/Db	- 4...20 mA HART, PROFIBUS PA, FOUNDATION Fieldbus	- XA01319P/00	Z

1) Product Configurator, "Approval" ordering feature

#### Installation/ Control Drawings

Directive	Electronic insert	Documentation	Option <sup>1)</sup>
FM DIP Cl.II,III Div.1 Gr.E-G, Zone 21,22	-	-	Q
FM NI Cl.I Div.2 Gr.A-D, Zone 2	-	- XA01065P	R
FM IS Class I, II, III, Division 1, Groups A - G; NI, Class I Division 2, Groups A - D; AEx ia	- 4 to 20 mA HART - PROFIBUS PA, FOUNDATION Fieldbus	- XA01061P - XA01062P	S
CSA IS Class I, II, III, Division 1, Groups A - G; Class I Division 2, Groups A - G	- 4 to 20 mA HART - PROFIBUS PA, FOUNDATION Fieldbus	- ZD00215P - ZD00217P	U
CSA C/US Cl.II, III Div.1 Gr.E-G	-	-	W

1) Product Configurator, "Approval" ordering feature

#### Overfill protection

WHG: ZE00266P/00/EN

## Registered trademarks

---

<b>HART®</b>	Registered trademark of the HART Communication Foundation, Austin, USA
<b>PROFIBUS®</b>	Registered trademark of the PROFIBUS User Organization, Karlsruhe, Germany
<b>FOUNDATION™ Fieldbus</b>	Registered trademark of Fieldbus Foundation, Austin, Texas, USA



71260302

[www.addresses.endress.com](http://www.addresses.endress.com)

---