

Technical information

Flow switch

Flowphant T DTT31, DTT35

Flow switch for safe monitoring of mass flow and temperature in industrial processes



Application

Flow switch for monitoring and displaying relative mass flow rates of liquid media in the range from 0.03 to 3 m/s (0.1 to 9.84 ft/s):

Flowphant T DTT31 – with thread connections or coupling

Flowphant T DTT35 – with process connections for hygienic applications

Application examples:

- Monitoring cooling water circulation systems of pumps, turbines, compressors and heat exchangers
- Monitoring pump functionality
- Leak monitoring in process lines
- Monitoring lubrication systems
- Filter monitoring in the beverage industry

Benefits at a glance

This compact flow switch impresses with the latest in technology being used:

- Practically no pressure loss
- Configuration software ReadWin 2000 or FieldCare for quick configuration and reliable storage of device settings
- Optional: 4 to 20 mA analog output to read out the flow rate as percentage value
- Optional: second switch output or 4 to 20 mA analog output for temperature monitoring
- Function check and process information onsite thanks to digital display at device
- Top housing section which can be rotated 310° and rotatable display make it possible to read the measured values in all orientations
- DTT35: 3-A marked

Function and system design

Measuring principle

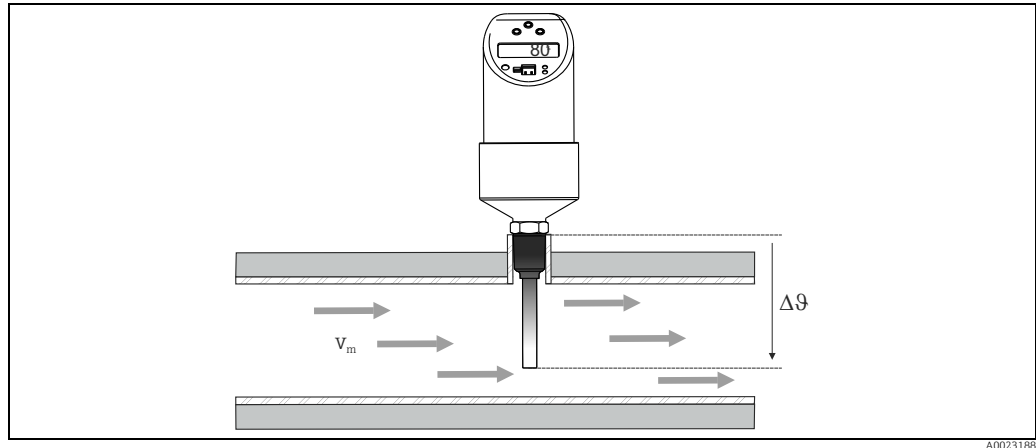

The device measures the mass flow of a liquid medium with the calorimetric measurement method. The calorimetric measuring principle is based on cooling a heated temperature sensor. Heat is removed from the sensor by forced convection due to medium flowing by. The extent of this heat transfer depends on the medium velocity and the difference in temperature between the sensor and medium (King's law). The higher the velocity or the mass flow of the medium, the greater the temperature sensor cooling.

Measuring system

Overview

Flowphant product family	DTT31	DTT35
	<p style="text-align: right;">A0005276</p>	<p style="text-align: right;">A0023194</p>
Measurement probe	RTD	RTD
Field of application	Monitoring of the mass flow of water, water-like substances and low-viscosity oils (viscosity: 0.184 to 20.0 mPa*s; thermal conductivity: 29 to 688 mW/mK). Example: Aqueous solution monoethylenglycol (20 vol%) at 20 °C: Viscosity: 1.65 mPa*s; thermal conductivity: 512 mW/mK	Monitoring of the mass flow of liquid media in hygienic processes (viscosity: 0.184 to 20.0 mPa*s; thermal conductivity: 29 to 688 mW/mK). Example: Aqueous solution monoethylenglycol (20 vol%) at 20 °C: Viscosity: 1.65 mPa*s; thermal conductivity: 512 mW/mK
Process connection	<ul style="list-style-type: none"> ■ Compression fitting ■ Thread: <ul style="list-style-type: none"> – G$\frac{1}{2}$" and G$\frac{3}{4}$" – ANSI NPT $\frac{1}{4}$" and NPT $\frac{1}{2}$" 	<ul style="list-style-type: none"> ■ Hygiene: <ul style="list-style-type: none"> – Conical metal-metal G$\frac{1}{2}$" – Clamp 1" - 1$\frac{1}{2}$", 2" – Varivent F, N – DIN 11851 – APV-Inline

Flowphant product family	DTT31	DTT35
Measuring range	Mass flow as a relative value between 0 and 100%. Process measuring limit, liquids: 0.03 to 3 m/s (0.1 to 9.84 ft/s)	

DC voltage version

PNP switch output of electronics.

Power supply e.g. with a power supply unit.

Preferably in conjunction with programmable logic controllers (PLC) or for controlling a relay.

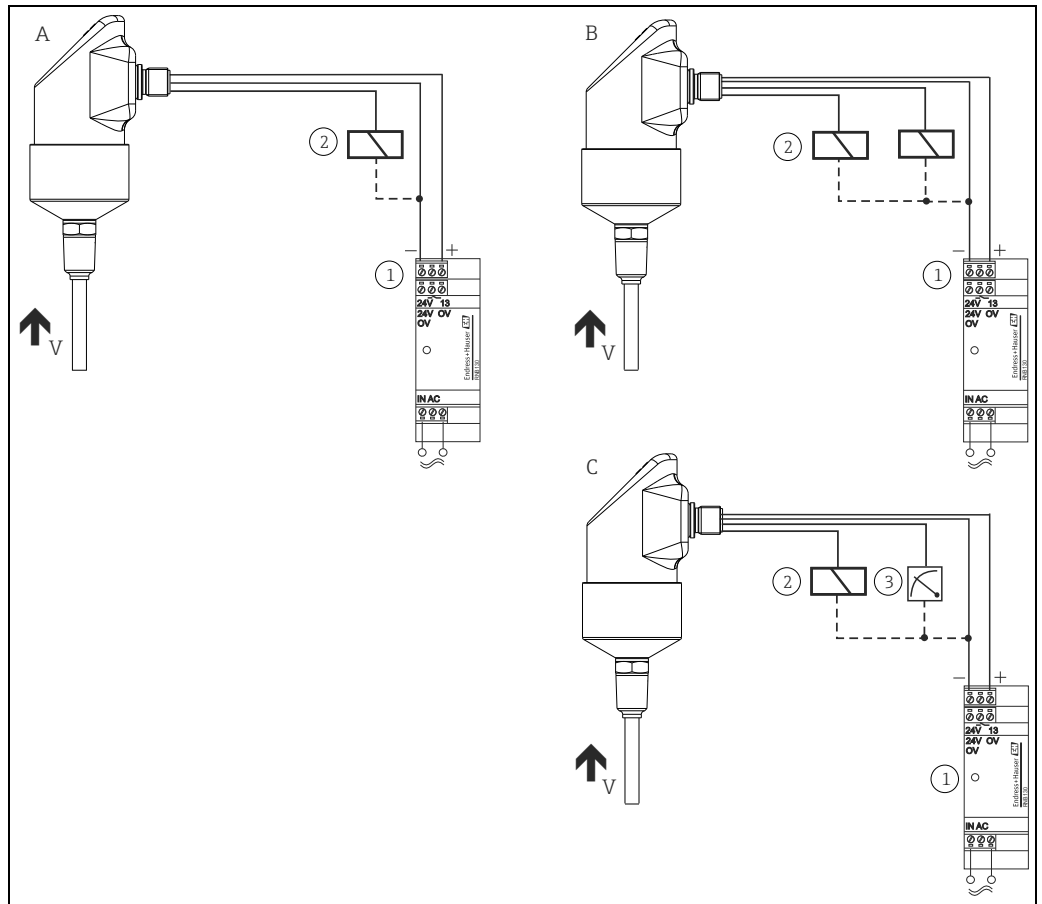

A: 1x PNP switch output
 B: 2x PNP switch output
 C: PNP switch output with additional analog output 4 to 20 mA

- @ Transmitter power supply unit, e.g. RNB130
- @ Load (e.g. programmable logic controller, process control system, relay)
- @ Display e.g. RIA452 or recorder e.g. Ecograph T or Minilog B (at 4 to 20 mA analog output)

@ Power supply "Easy Analog RNB130":

Primary switched-mode power supply for sensors. Space saving DIN rail mounting as per IEC 60715. Wide-range nominal voltage input: 100 to 240 V AC; Output: 24 V DC, max. 30 V in the event of a fault; Nominal output current: 1.5 A. Connection to monophased a.c. networks or to two phase conductors of three-phase supply networks.

@ Process display RIA452:

If you would like to read off the instantaneous value of the temperature not only locally, but also e.g. directly from a control room or in the PC network, then one suitable device is the process display RIA452:
 Digital process display unit in 96 x 96 mm (3.78 x 3.78 in) panel mounted housing for monitoring and displaying analog measured values with pump control and batch functions. Multicoloured 7-digit 14-

segment LC display with large bargraph. Configuration and visualisation via RS232 interface and ReadWin 2000 PC operating software.

③ *Universal Graphic Data Manager Ecograph T, Data logger Minilog B:*

If you would like to read off the instantaneous value of the temperature not only locally, but also record, analyze and display it e.g. directly from a control room or in the PC network, then the following devices are suitable:

- **Universal Graphic Data Manager Ecograph T**
144 x 144 mm (5.67 x 5.67 in) panel mounted housing for electronic acquisition, display, recording, analysis, remote transmission and archiving of analog and digital input signals. Multichannel data recording system with multicoloured TFT display (145 mm (5.7 in) screen size), galvanically isolated universal inputs (U, I, TC, RTD, pulse, frequency), digital inputs, transmitter power supply, limit relay, communication interfaces (USB, Ethernet, optional RS232/485), 128 MB internal memory, external SD card and USB stick. The Field Data Manager Software (FDM) supports data analysis at the PC; configuration is done via FieldCare or the integrated web server.
- **Data logger Minilog B**
Battery powered measured value collector with 2 input channels for storing analog and digital values. Internal memory 128 kB for max. 84000 measured values. Configuration and visualisation via RS232 interface and ReadWin 2000 PC operating software. Optionally with telealarm function.

Input

Measured variable	<ul style="list-style-type: none"> ▪ Flow velocity of liquid media (calorimetric measuring principle) ▪ Temperature (RTD), optional for two switch outputs or additional analog output
Measuring range	<ul style="list-style-type: none"> ▪ Flow: 0.03 m/s to 3 m/s (0.1 to 9.84 ft/s), as relative value between 0 and 100%; maximum display resolution: 1% ▪ Temperature: -20 °C to +85 °C (-4 to +185 °F); display resolution: 1 °C (1 °F)

Output

Output signal	<p>DC voltage version: (short-circuit proof version)</p> <ul style="list-style-type: none"> ▪ 1x PNP switch output (flow) or ▪ 2x PNP switch outputs (flow or temperature, adjustable) or ▪ 1x PNP switch output and 1x 4 to 20 mA output, active (flow or temperature, adjustable) <p> The analog output reads out the measured flow rate as relative value in percentage of the adjusted measuring range.</p>
Signal on alarm	<p>Signal on alarm as per NAMUR NE43</p> <ul style="list-style-type: none"> ▪ Underranging: Linear drop to 3.8 mA ▪ OVERRANGING: Linear rise to 20.5 mA ▪ Sensor break; sensor short-circuit: ≤ 3.6 mA or ≥ 21.0 mA (at settings ≥ 21.0 mA, 21.7 mA output is guaranteed) ▪ Switch outputs: at safety condition (switch open)
Load	<p>Max. $(V_{\text{power supply}} - 6.5 \text{ V}) / 0.022 \text{ A}$ (current output)</p>
Range of adjustment	<ul style="list-style-type: none"> ▪ Switch output Switch point (SP) and switchback point (RSP) in increments of 1% with min. hysteresis of 5% ▪ Damping: freely adjustable: 0 = off (no damping) or 10 to 40 s in increments of 1 second ▪ Unit: %, optional °C, °F (with two outputs and temperature monitoring)

Switching capacity

DC voltage version:

- Switch status ON: $I_a \leq 250 \text{ mA}$, switch status OFF: $I_a \leq 1 \text{ mA}$
- Switching cycles: $> 10,000,000$
- Voltage drop PNP: $\leq 2 \text{ V}$
- Overload protection

Automatic testing of switching current; output is switched off in case of overcurrent, the switching current is tested again every 0.5 s; max. capacitance load: $14 \mu\text{F}$ for max. supply voltage (without resistive load)

Periodic disconnection from a protective circuit in event of overcurrent ($f = 2 \text{ Hz}$) and indication of 'Warning'

Inductive load

To prevent electrical interference, only operate an inductive load (relays, contactors, solenoid valves) when directly connected to a protective circuit (free-wheeling diode or capacitor).fdg

Power supply

Electrical connection

Plug connection



DTT35: Electrical cables must comply with 3-A standard, must be smooth, corrosion resistant and cleanable.

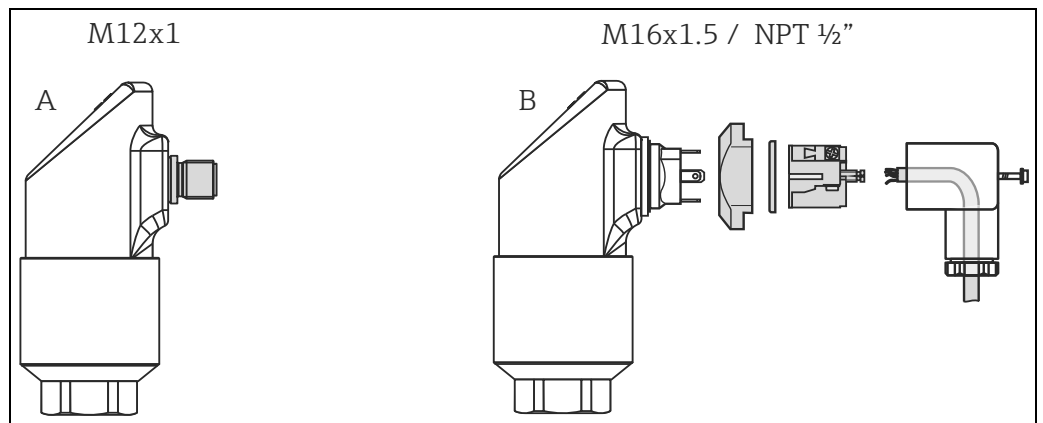

A: M12x1 connector
B: Valve connector M16x1.5 or NPT 1/2"

Device connection

- DC voltage version with M12x1 connector

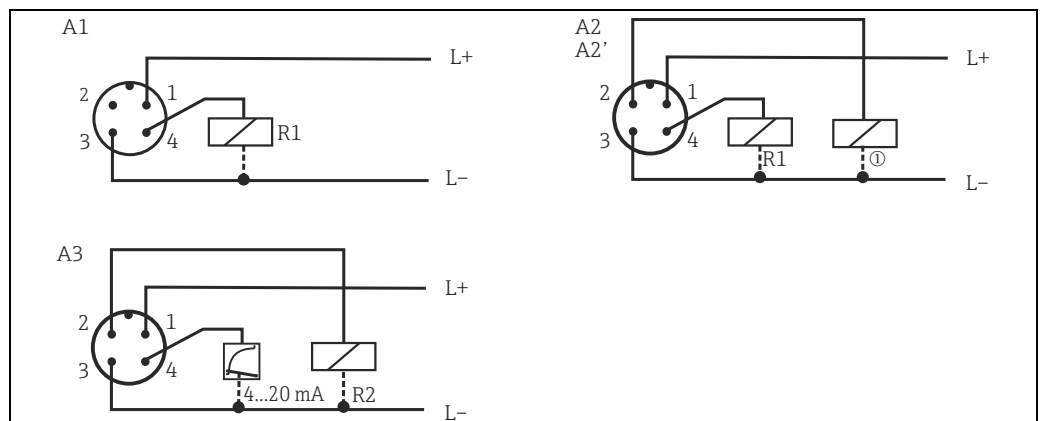

A0006818

Item No.	Output setting	Order code (see Ordering information section)
A1	1x PNP switch output	DTT3x-A1A*****
A2	2x PNP switch output R1 and m (R2)	DTT3x-A1B*****
A2'	2x PNP switch output R1 and m (diagnosis/NC contact with "DESINA" setting)	DTT3x-A1B*****
A3	1x PNP switch output and 1x analog output (4 to 20 mA)	DTT3x-A1C*****

- DC voltage version with valve connector M16x1.5 or NPT 1/2"

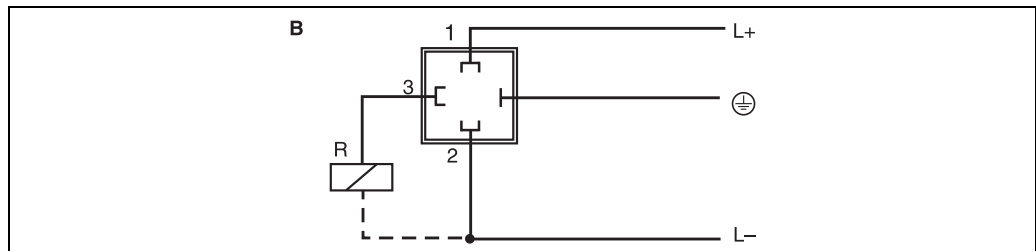

P01-PTx3xxxx-04-xx-xx-xx-003

Item No.	Output setting	Order code (see Ordering information section)
B	1x PNP switch output	DTT3x-A2A*****; DTT3x-A3A*****

Supply voltage DC voltage version
18 up to 30 V DC (reverse polarity protection)

Current consumption < 100 mA (without load) at 24 V DC, max. 150 mA (without load); with reverse polarity protection

Power supply failure

- Behaviour in case of overvoltage (> 30 V)
The device works continuously up to 34 V DC without any damage.
No damage is caused to the device in case of a short-term overvoltage up to 1 kV (as per EN 61000-4-5).
The specific properties are no longer guaranteed if the supply voltage is exceeded.
- Behaviour in case of undervoltage
If the supply voltage drops below the minimum value, the device switches off (status as if not supplied with power = switch open).

Performance characteristics

The percentage information in the "Performance characteristics" section refers to the full scale value or the set maximum value (100% value) of the monitoring range.

Reference operating conditions As per DIN IEC 60770 or DIN IEC 61003
T = 25 °C ± 5 °C (77 °F ± 9 °F), relative humidity 45 to 75 %, ambient air pressure 860 to 1060 kPa (124 to 153 PSI), water test medium. Supply voltage U = 24 V DC.

Maximum measured error **Flow**
The device records fluid velocity relatively in relation to a set monitoring range of the flow (0 to 100 % as display value). An absolute measurement of the fluid velocity or the mass flow is not possible. The sensitivity of the calorimetric flow sensor changes with the fluid velocity. It increases with decreasing

fluid velocity (for example, with water, the greatest sensor sensitivity is recorded in the range from 0.03 to 0.5 m/s).

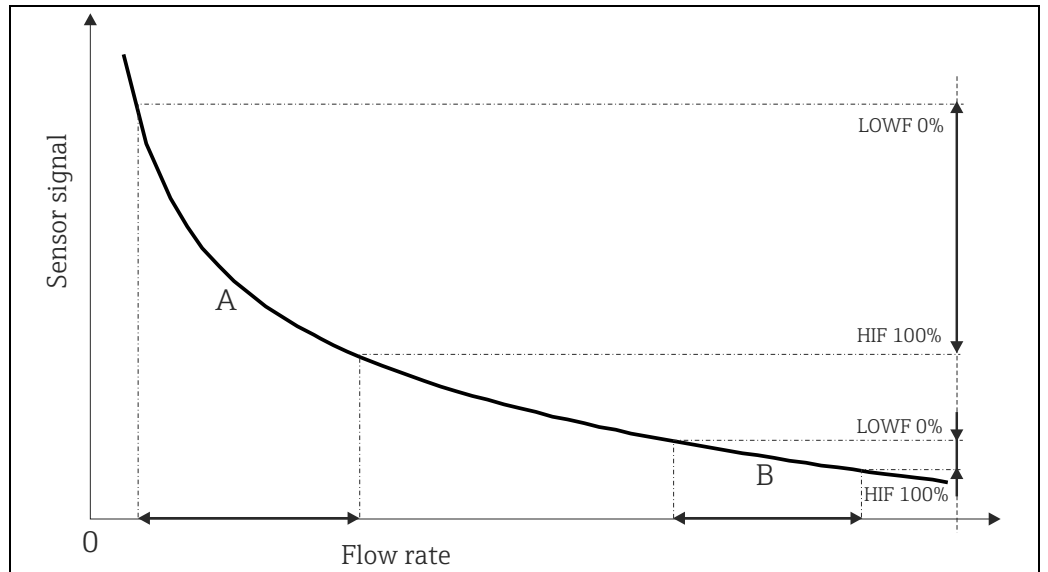

Standard characteristic

A, B: Set monitoring ranges of the flow (example)

LOWF 0%: Setting for the minimum fluid velocity occurring in the monitoring range A or B (0% value)

HIF 100%: Setting for the maximum fluid velocity occurring in the monitoring range A or B (100% value)

Temperature

- Accuracy: 2 K (3.6 °F)
- Repeatability: 1 K (1.8 °F)
- Influence of medium temperature: 0.05 %/K of full scale value

Switch point non-repeatability

Measuring range (water as medium)	% of maximum value	Influence of medium temperature ¹⁾	Influence of ambient temperature
0.03 to 0.5 m/s (0.1 to 1.6 ft/s)	≤ 2 % ²⁾	0.05 %/K	0.04 %/K
0.03 to 1 m/s (0.1 to 3.28 ft/s)	≤ 3 % ²⁾	0.10 %/K	0.05 %/K
0.03 to 2 m/s (0.1 to 6.56 ft/s)	≤ 5 % ²⁾	0.15 %/K	0.10 %/K
0.03 to 3 m/s (0.1 to 9.84 ft/s)	≤ 10 % ²⁾	0.20 %/K	0.30 %/K

1) The values indicated only apply to the device itself without taking the temperature-dependent change of the thermo-physical properties of the medium into account. For this reason, we recommend you commission the device at the process temperature and set the switch points (see 'Learn function' → 13)

2) For a Reynolds number > 10,000

Temperature gradient

In the event of a temperature change of ≥ 0.5 K/min in the medium, temporary display drifts are possible which can exceed the specified non-reproducibility values of the switch point.

Sensor reaction time

6 to 12 s

Long-term drift

0.5% per year under reference operating conditions

Long-term reliability

Mean time between failure (MTBF) calculated according to SN29500 (at 40 °C)	
Low stress environment: <0.1G	227 years
High stress environment: >0.1G	48 years

Switch output response time 100 ms

Analog output

- Maximum measured error = switch point error and display error + 0.1%
- Rise time T_{90} : ≤ 200 ms
- Settling time T_{99} : ≤ 500 ms

Operating conditions: Installation instructions

Installation instructions

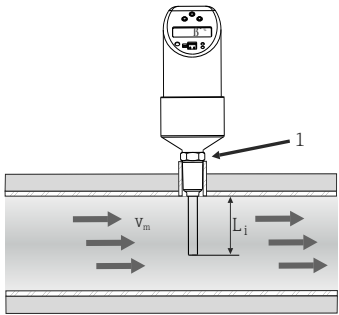
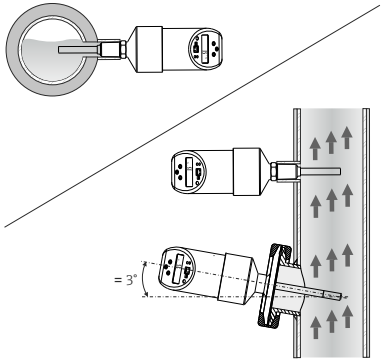
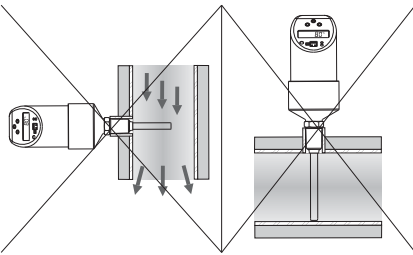
<ul style="list-style-type: none"> ▪ The sensor tip should be completely surrounded by medium. ▪ Position the sensor tip in the area of maximum fluid velocity (pipe center). ▪ Minimum sensor immersion length: $L_i \geq 10$ mm (0.4 in) 	 <p style="text-align: right;">A0006976</p> <p style="text-align: center;"><i>Installation conditions</i></p>
<p>Orientation</p> <ul style="list-style-type: none"> ▪ For horizontal pipes: lateral installation. Installation from above only if the pipe is completely filled with medium. ▪ For vertical pipes: installation in the ascending pipeline. ▪ DTT35: min. 3° inclination, because of self draining. 	 <p style="text-align: right;">A0006977</p> <p style="text-align: center;"><i>Correct orientation</i></p>
<p>NOTICE</p> <p>Do not install in down pipes open towards the end. The sensor tip should never touch the pipe wall.</p>	 <p style="text-align: right;">A0006978</p> <p style="text-align: center;"><i>Incorrect installation!</i></p>

- Electrical rotation of display by 180°
- Housing can be rotated up to 310 ° mechanically

Orientation

No restrictions, but self draining.

Inlet and outlet run

NOTICE

The thermal measuring principle is sensitive to disturbed flow conditions.

- ▶ As a general rule, install the measuring device as far away as possible from any flow disturbances. For further information → ISO 14511.
- ▶ If possible, install the sensor upstream from fittings such as valves, T-pieces, elbows, etc.
- ▶ To attain the specified level of accuracy of the measuring device, the inlet and outlet runs mentioned below must be maintained at the very minimum.
- ▶ If there are several flow disturbances present, the longest specified inlet run must be maintained.

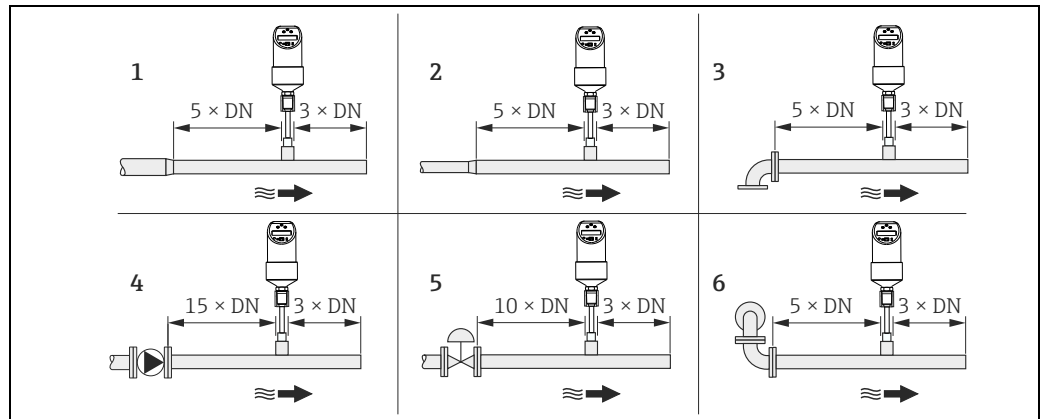

- 1 Reduction
- 2 Expansion
- 3 90° elbow or T-section
- 4 Pump
- 5 Control valve
- 6 2x 90° elbow 2- or 3-dimensional

A0023225

Operating conditions: Environment

Ambient temperature range -40 to +85 °C (-40 to +185 °F)

Storage temperature -40 to +85 °C (-40 to +185 °F)

Climate class 4K4H as per DIN EN 60721-3-4

Degree of protection IP65 (optional IP66, depending on used connector)

Shock resistance 50 g as per DIN IEC 68-2-27 (11 ms)

Vibration resistance

- 20 g as per DIN IEC 68-2-6 (10-2000Hz)
- 4 g as per German Lloyd GL Guidelines

Electromagnetic compatibility

- Interference emission as per IEC 61326 Series, class B electrical equipment
- Interference immunity as per IEC 61326 Series, appendix A (industrial use) and NAMUR Recommendation NE 21

EMC influence: ≤ 0.5 %

Operating conditions: Process

Process temperature limits	-20 to +85 °C (-4 to +185 °F) The sensor can be exposed up to 130 °C (266 °F) without damage; monitoring switches off automatically at $T \geq 85$ °C (185 °F) and starts again at $T \leq 85$ °C (185 °F).
Process pressure limits	Maximum permitted process pressure $p_{\max} \leq 10$ MPa = 100 bar (1450 psi) NOTICE The maximum process pressure for the conical metal-metal process connection (MB option) for the DTT35 is 1.6 MPa = 16 bar (232 psi)!
Process flow limit	Liquids: 0 up to 3.0 m/s (0 up to 9.84 ft/s)
Operating range	Liquids: 0.03 up to 3.0 m/s (0.1 up to 9.84 ft/s)

Mechanical construction

Design, dimensions DTT31, DTT35

Dimensions

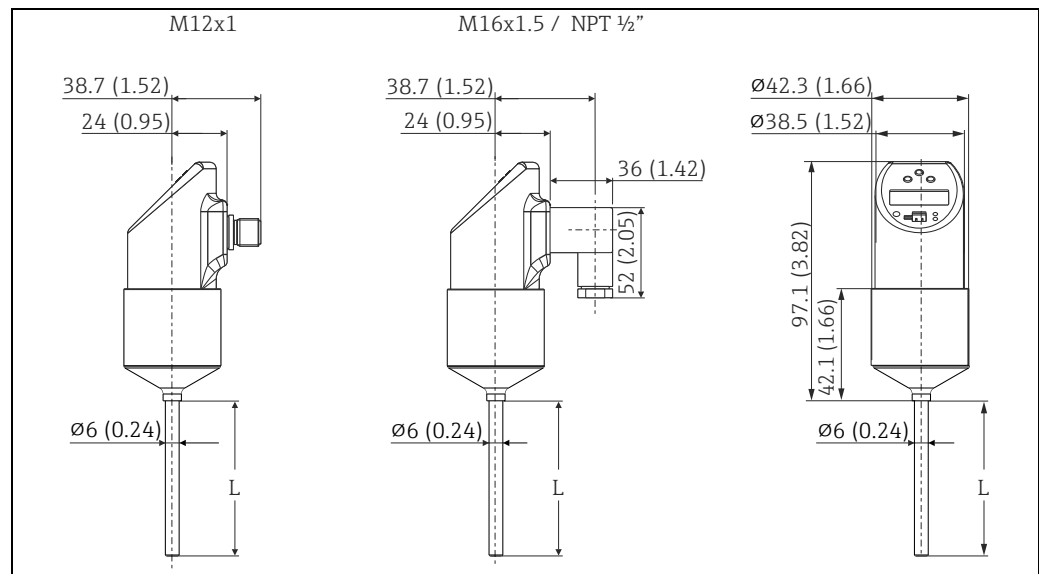

All dimensions in mm (in)

L = Insertion length

Connector M12x1 as per IEC 60947-5-2

Valve connector M16x1.5 or NPT 1/2" as per DIN 43650A/ISO 4400

A0005279

DTT31 design, dimensions for process connections

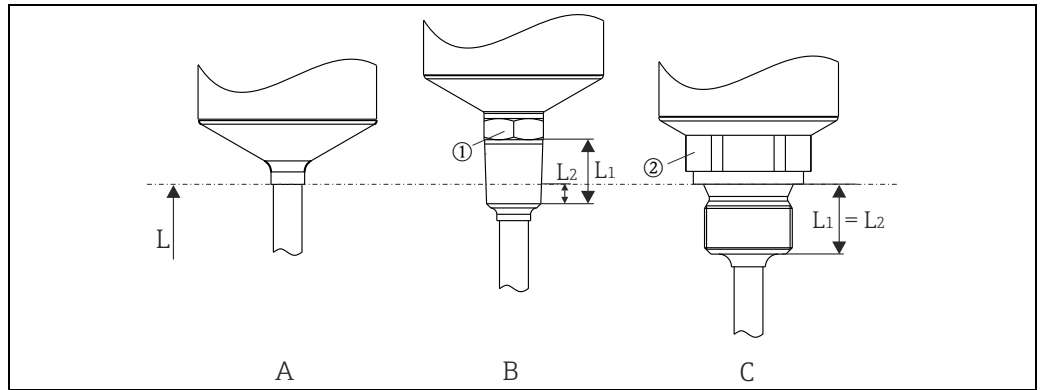

A0007101

Process connections DTT31

Item No.	Version DTT31	Insertion length L	Thread length L ₁	Screw-in length L ₂
A	Without process connection. For suitable welding bosses and compression fittings see 'Accessories'.		-	-
B	Threaded process connection: <ul style="list-style-type: none"> ANSI NPT 1/4" (⊙ = AF14) ANSI NPT 1/2" (⊙ = AF27) 	30 and 100 mm (1.18 and 3.94 in)	<ul style="list-style-type: none"> 14.3 mm (0.56 in) 19 mm (0.75 in) 	<ul style="list-style-type: none"> 5.8 mm (0.23 in) 8.1 mm (0.32 in)
C	Cylindrical threaded process connection in inches as per ISO 228: <ul style="list-style-type: none"> G 1/4" (⊙ = AF14) G 1/2" (⊙ = AF27) 		<ul style="list-style-type: none"> 12 mm (0.47 in) 14 mm (0.55 in) 	-

DTT35 design, dimensions for process connections

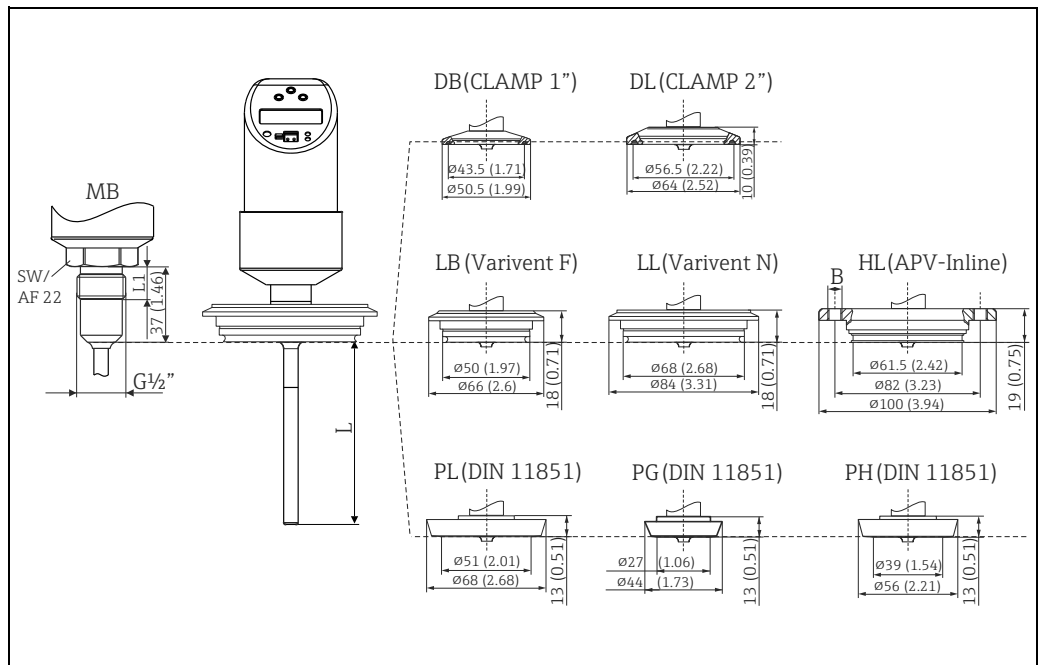

A0011776

All dimensions in mm (in)

L = insertion length

Item No.	Process connection versions DTT35
MB	Conical metal-metal for hygienic processes, G 1/2" thread. Suitable welding boss available as an accessory. Thread length L ₁ = 14 mm (0.55 in)
DB	Clamp 1" up to 1 1/2" (ISO 2852) or DN 25 up to DN 40 (DIN 32676)

Item No.	Process connection versions DTT35
DL	Clamp 2" (ISO 2852) or DN 50 (DIN 32676)
LB	Varivent F DN25-32, PN 40
LL	Varivent N DN40-162, PN 40
HL	APV inline, DN 50, PN 40, 316L, (B = 6 x Ø8.6 bores + 2 x M8 thread)
PL	DIN 11851, DN50, PN40 (including coupling nut)
PG	DIN 11851, DN25, PN40 (including coupling nut)
PH	DIN 11851, DN40, PN40 (including coupling nut)

Weight approx. 300 g (10.6 oz), depends on sensor length and process connection

- Material**
- Process connection: AISI 316L
Surfaces in contact with process in hygienic version with surface quality $R_a \leq 0.8 \mu\text{m}$
Coupling nut: AISI 304
 - Housing: AISI 316L, with surface quality $R_a \leq 0.8 \mu\text{m}$ (31.5 μin)
O ring between housing and sensor modul: EPDM
 - Electrical connection:
M12 connector: exterior AISI 316L, interior polyamide (PA)
Valve plug: outer polyamide (PA)
M12 connector: exterior 316L
Cable outer covering: polyurethane (PUR)
O ring between electrical connection and housing: FKM
 - Display: Polycarbonate PC-FR (Lexan®)
Seal between display and housing: SEBS THERMOPLAST K®
 - Keys: Polycarbonate PC-FR (Lexan®)

Human interface

Operating elements Position of display and operating elements

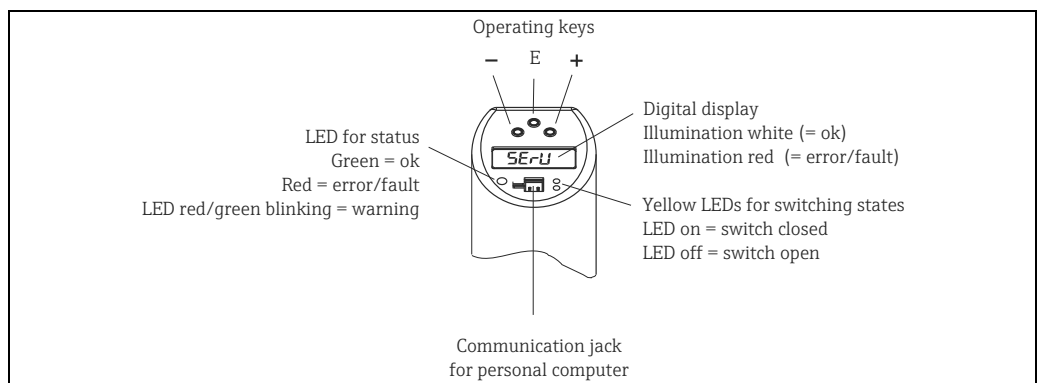



A0020825-EN

Onsite operation

Menu-guided operation using operating keys.

Function group	Function (display)	Description
BASE (basic functions)	Display (DISP)	Display assignment: - OFF - Display of current measured value or of configured switch point (switch 1) - Display of current measured value or of configured switch point (switch 1) rotated 180° - Display of current medium temperature - Display of current medium temperature rotated 180° Factory setting: current measured value
	UNIT	Display medium temperature unit °C or °F Factory setting: °C  Only visible if the current medium temperature is selected in the DISP mode.
	Damping (TAU)	Measured value damping with regard to display value and output: 0 (no damping) or 9 to 40 s (in increments of 1 second) Factory setting: 0 s
	DESINA (DESI) Only for 2 x PNP switch outputs	Behavior as per DESINA: The PIN of the M12 connector is assigned in accordance with the guidelines of DESINA. (DESINA = DistributEd and Standardized INstAllation technology for machine tools and manufacturing systems)
CAL (calibration)	Learn High Flow (HIF)	Setting for maximum flowrate occurring. 100% value
	Learn Low Flow (LOWF)	Setting for minimum flowrate occurring. 0% value

Function group	Function (display)	Description
OUT (Setting for the 1st output) OUT2 (Setting for the 2nd output, optional)	Switching mode (MODE)	Output switching mode for channel 2: flow or temperature Factory setting: flow
	UNIT	Temperature unit selection (°C/°F)  Function only visible if switching mode (MODE) is set to temperature in the 2nd output.
	Function 1 (FUNC) Function 2 (FNC2), optional	Switch output function: hysteresis function NC contact or NO contact (see diagram)
	Switch point (SP) Switch point 2 (SP2), optional	<ul style="list-style-type: none"> Enter value 5 to 100% in increments of 1%, only if High and Low Flow (HIF and LOWF) have been configured beforehand. Factory setting: 50% Or optionally for SP2: <ul style="list-style-type: none"> Enter value -15 to 85 °C (-5 to 185 °F) in increments of 1 °C (1 °F) if the switching mode (MODE) is set to temperature. Factory setting: 55 °C
	Switch point learn (SPL) Switch point learn 2 (SP2L), optional	Take current flowrate as SP.
	Switch-back point (RSP) Switch-back point 2 (RSP2), optional	<ul style="list-style-type: none"> Enter value 0 to 95% in increments of 1%. Factory setting: 40%  Value has to be at least 5% smaller than switch point 2 (SP2). Or optionally for RSP2: <ul style="list-style-type: none"> Enter value -20 to 80 °C (-4 to 176 °F) in increments of 1 °C (1 °F) if the switching mode (MODE) is set to temperature. Factory setting: 50 °C  Value has to be at least 5 °C (9 °F) smaller than switch point 2 (SP2).
	Switch point delay (TSP) Switch point 2 delay (TSP2), optional	Can be set anywhere between 0 and 99 s in increments of 1 second. Factory setting: 0 s
Analog output 4-20 (Setting for the analog output, optional)	Switchback point delay (TRSP) Switchback point delay 2 (TRSP2)	Can be set anywhere between 0 and 99 s in increments of 1 second. Factory setting: 0 s
	Output mode (MODE)	Process value for analog output: flow rate or temperature Factory setting: FLOW
SERV (service functions)	Error current (FCUR)	Current value in event of error: alternatively MIN = ≤ 3.6 mA, MAX = ≥ 21.7 mA, HOLD = last current value Factory setting: MAX
	Preset (PRES)	Resetting of all settings to factory settings.
	Static revision counter (REVC)	Configuration counter, incremented each time the configuration is changed.
	Operating code (LOCK)	Enter the device locking code.
	Edit operating code (CODE)	Locking, only visible with valid operating code.
	Device status (STAT)	
Simulation: switch output version	Last error (LSTA)	Display of last error to occur.
	Simulation 1 (SIMU) Simulation 2 (SIM2), optional	Simulation switch output 1: on/off with display, optionally corresponding to switch output 2.

Function group	Function (display)	Description
Simulation: analog output version (4 to 20 mA)	<ul style="list-style-type: none"> ■ Simulation 1 (SIM) - switch output ■ Simulation 2 (SIMA) - analog output 	<ul style="list-style-type: none"> ■ Simulation switch output 1: on/off with display ■ Simulation values for analog output in mA.

Switch-point function

- Hysteresis function
The hysteresis function enables two-point control via a hysteresis. Depending on the flow, the hysteresis can be set via the switch point SP and the switch-back point RSP.
- NO contact or NC contact.
This switch function is freely selectable.
- Delay times for switch point SP and switch-back point can be set in increments of 1 s. By this means undesirable temperature peaks of short duration or of high frequency can be filtered out.

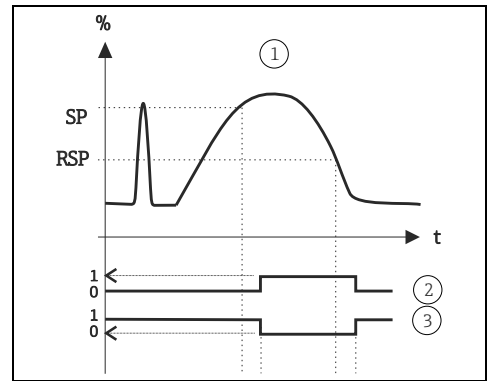

① Hysteresis function, ② NO contact, ③ NC contact
SP switch point; RSP switch-back point

Remote operation via PC

Operation, visualization and maintenance with PC and PC configuration software ReadWin 2000 or FieldCare.

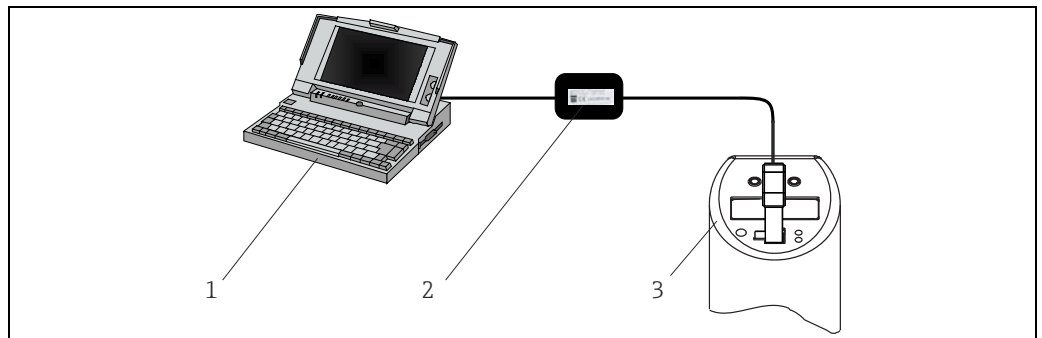

Operation, visualization and maintenance with PC and configuration software.

- Item 1: PC with ReadWin 2000 or FieldCare configuration software
- Item 2: TXU10-AA or FXA291 configuration kit (see "accessories")
- Item 3: Flow switch

In addition to the operating options listed in the previous "Onsite operation" section, the ReadWin 2000 configuration software or FieldCare provides further information on the Flowphant T:

Function group	Function (display)	Description
SERV (service functions)	Switching processes 1 Switching processes 2, optional	Number of changes in switching status for switch output 1; optionally switch output 2

Function group	Function (display)	Description
INFO (device information)	TAG 1 TAG 2, optional	Tagging, 18-digit
	Order code	Order code
	Serial number	Device serial number
	Sensor serial number	Sensor serial number
	Electronics serial number	Electronics serial number
	Device revision	Display of entire revision
	Hardware revision	Hardware version
	Software revision	Software version

Certificates and approvals

CE-Mark	The device meets the legal requirements of the EC directives. Endress+Hauser confirms that the device has been successfully tested by applying the CE mark.
GL	Ship building approval (Germanischer Lloyd)
Other standards and guidelines	<ul style="list-style-type: none"> ▪ IEC 60529: Degree of protection by housing (IP-Code) ▪ IEC 61010-1: Safety requirements for electrical measurement, control and laboratory instrumentation. ▪ IEC 61326-series: Electrical equipment for measurement, control and laboratory use - EMC requirements. ▪ NAMUR: User association of automation technology in process industries (www.namur.de) ▪ NEMA: Standardization association for the electrical industry in North America.
Hygiene standard	The DTT35 flow switch meets the requirements of Sanitary Standard no. 74-06. Endress+Hauser confirms this by applying the 3-A symbol (depending on the selected process connection).
UL listed for Canada and USA	The device was examined by Underwriters Laboratories Inc. (UL) in accordance with the standards UL 61010B-1 and CSA C22.2 No. 1010.1-92 and listed under the number E225237 UL.

Ordering information

Detailed ordering information is available from the following sources:

- In the **Product Configurator** on the Endress+Hauser website:
www.endress.com → Select country → Instruments → Select device → Product page function:
Configure this product
- From your Endress+Hauser Sales Center:
www.endress.com/worldwide



Product Configurator - the tool for individual product configuration:

- Up-to-the-minute configuration data
- Depending on the device: Direct input of measuring point-specific information such as measuring range or operating language
- Automatic verification of exclusion criteria
- Automatic creation of the order code and its breakdown in PDF or Excel output format
- Ability to order directly in the Endress+Hauser Online Shop

Accessories

All dimensions in mm (in).

EN10204-3.1 = Material certificate (melt analysis)

Welding boss with sealing taper for DTT31

Collar welding boss moveable with sealing taper and pressure screw;
 material of parts in contact with the process: 316L, PEEK, max. process pressure 10 bar (145 PSI)
 Order number: 51004751

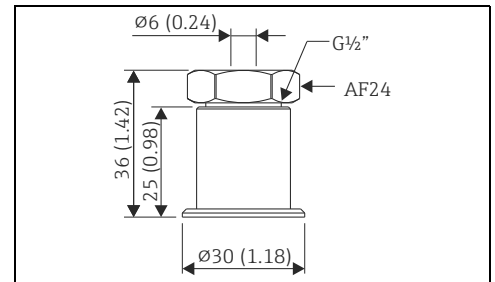

A0020709-EN

Collar welding boss for DTT31

Material of parts in contact with process: 316L
 Order number: 51004752

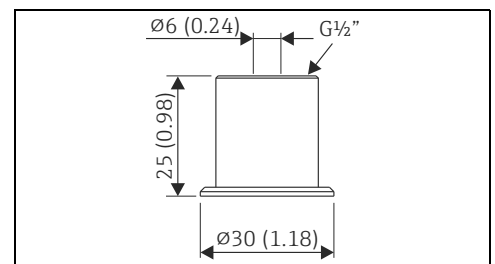

A0020710

Coupling for DTT31

moveable coupling, G1/2" process connection,
 coupling and parts in contact with process: 316L
 Order number: 51004753

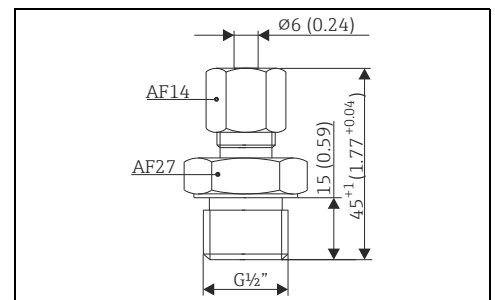

A0020174-EN

Welding boss with sealing taper (metal-metal) for DTT35

Welding boss for G1/2" thread
 Seal, metal-metal,
 Material of parts in contact with process: 316L/
 1.4435
 Max. process pressure 16 bar (232 PSI)
 Order number: 60021387

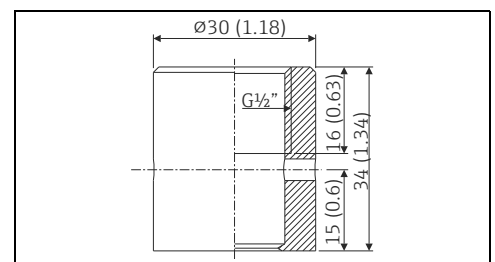

A0006621

Coupling

Coupling M12x1 for simple user installable
 assembly of the connecting cable; straight
 connection to M12x1 housing connector
 Order number: 52006263

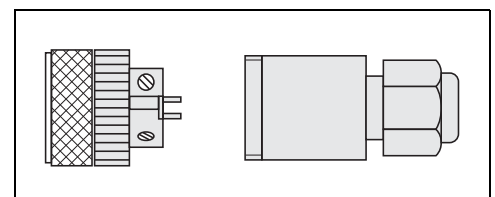

P01-PMP13xxx-00-xx-00-xx-003

Coupling

Coupling M12x1 for simple user installable assembly of the connecting cable; elbowed; connection to M12x1 housing connector IP67, PG7
 Order number: 51006327

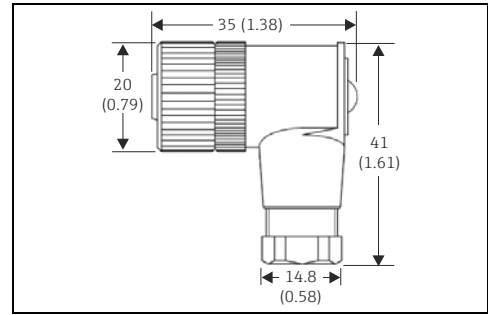

A0020722

Connecting cable (pre-assembled)

PVC cable, 4 x 0.34 mm² (22 AWG) with M12x1 coupling, elbowed, screw plug, length 5 m (16.4 ft), IP67
 Order number: 51005148
 Core colours:
 - 1 = BN brown
 - 2 = WH white
 - 3 = BU blue
 - 4 = BK black

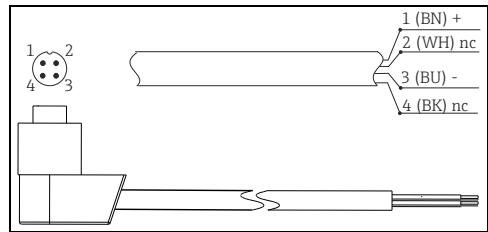

A0020723

Connecting cable with LED

PVC cable, 4 x 0.34 mm² (22 AWG) with M12x1 coupling, with LED, elbowed, 316L screw plug, length 5 m (16.4 ft), specially for hygiene applications, IP69K
 Order number: 52018763
 Display:
 -gn: device operational
 -ye1: switch status 1
 -ye2: switch status 2

 Not for use at devices with "4 to 20 mA analog output" option!

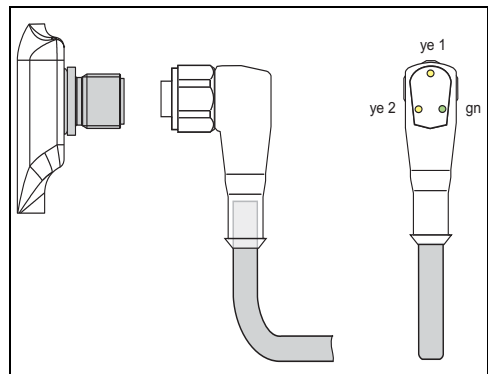

T09-TTR31xxx-00-00-xx-xx-001

Configuration kit

- Configuration kit for PC-programmable transmitters - ReadWin 2000 setup program and interface cable for PCs with USB port. Adapter for transmitters with 4-pole post connector.
 Order code: **TXU10-AA**
- Configuration kit "Commubox FXA291" with interface cable for PCs with USB port. Intrinsically safe CDI interface (Endress+Hauser Common Data Interface) for transmitters with 4-pole post connector. Suitable device configuration tool is e.g. FieldCare.
 Order code: **FXA291**

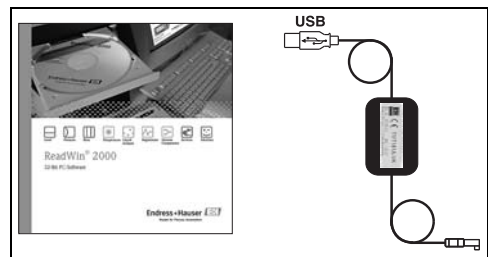

A0008067

Configuration software

- ReadWin 2000 and FieldCare 'Device Setup' can be downloaded free of charge directly from the internet at the following addresses:
www.endress.com/readwin
www.products.endress.com/fieldcare

For the order of the FieldCare 'Device Setup' software please ask your Endress+Hauser sales organisation.

Power supply

- Power supply Easy Analog RNB130 by Endress+Hauser with nominal output current $I_N = 1.5 \text{ A}$. Details see Technical information **TI120R/09/en**.
- Process display RIA452 by Endress+Hauser with transmitter power supply, max. output current $I = 250 \text{ mA}$. Details see Technical information **TI113R/09/en**.

Documentation

Technical information

- Easy Analog RNB130: TI120R/09/en
- Process display RIA452: TI113R/09/en
- Universal Data Manager Ecograph T: TI01079R/09/en
- Datalogger Minilog B: TI089R/09/en

Operating manual

- Flow switch Flowphant T DTT31, DTT35: BA00235R/09/en
- Configuration software ReadWin 2000: BA137R/09/en

www.addresses.endress.com
