

Technical Information

Proline Promag L 400

Electromagnetic flowmeter

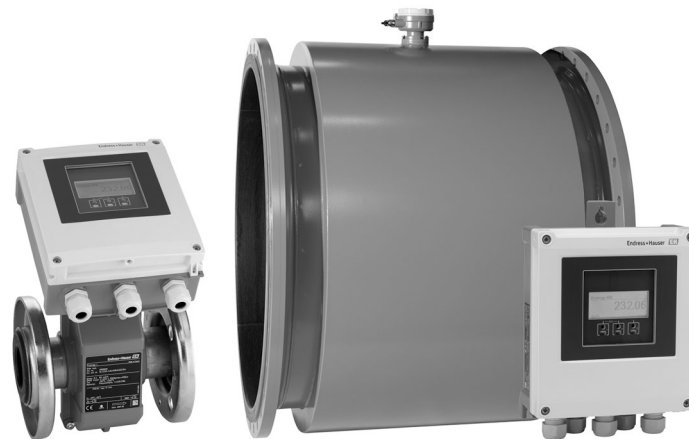

The flowmeter with integrated web server and a weight-optimized sensor

Application

- The electromagnetic measuring principle is unaffected by pressure, temperature and flow profile
- Fully suitable for standard applications in the water and wastewater industry

Device properties

- Up to 30 % less sensor weight
- Nominal diameter: DN 50 to 2400 (2 to 90")
- Maximum reduced installation length to DVGW/ISO
- Transmitter housing made of durable polycarbonate
- Same housing concept for compact/remote version
- Integrated data logger: measured values monitoring

Your benefits

- Reduced installation costs – flexible mounting by one-of-a-kind lap-joint flange concept (DN < 350/14")
- Energy-saving flow measurement – no pressure loss due to cross-section constriction
- Maintenance-free – no moving parts
- Safe operation – no need to open the device due to display with touch control, background lighting
- Time-saving local operation without additional software and hardware – integrated web server
- Integrated verification – Heartbeat Technology™







Table of contents

Document information	3	Electromagnetic compatibility (EMC)	30
Symbols used	3		
Function and system design	4	Process	30
Measuring principle	4	Medium temperature range	30
Measuring system	5	Conductivity	30
Safety	5	Pressure-temperature ratings	30
		Pressure tightness	33
Input	6	Flow limit	34
Measured variable	6	Pressure loss	34
Measuring range	6	System pressure	34
Operable flow range	8	Vibrations	34
Input signal	8		
		Mechanical construction	35
Output	8	Design, dimensions	35
Output signal	8	Weight	51
Signal on alarm	10	Measuring tube specification	56
Low flow cut off	11	Materials	58
Galvanic isolation	11	Fitted electrodes	60
Protocol-specific data	11	Process connections	60
		Surface roughness	60
Power supply	14	Operability	61
Terminal assignment	14	Operating concept	61
Pin assignment, device plug	16	Local operation	61
Supply voltage	16	Remote operation	62
Power consumption	17		
Current consumption	17	Certificates and approvals	63
Power supply failure	17	CE mark	63
Electrical connection	17	C-Tick symbol	63
Potential equalization	19	Drinking water approval	63
Terminals	21	EtherNet/IP certification	63
Cable entries	21	Other standards and guidelines	63
Cable specification	22		
		Ordering information	64
Performance characteristics	23		
Reference operating conditions	23	Application packages	64
Maximum measured error	23	Cleaning	64
Repeatability	24	Diagnostics functions	65
Influence of ambient temperature	24	Heartbeat Technology	65
Installation	24	Accessories	65
Mounting location	24	Device-specific accessories	65
Orientation	26	Communication-specific accessories	66
Inlet and outlet runs	26	Service-specific accessories	66
Adapters	27	System components	67
Length of connecting cable	27		
Installing the wall-mount housing	28	Documentation	67
Special mounting instructions	29	Standard documentation	67
		Supplementary device-dependent documentation	67
Environment	29		
Ambient temperature range	29	Registered trademarks	67
Storage temperature	29		
Atmosphere	30		
Degree of protection	30		
Shock resistance	30		
Vibration resistance	30		
Mechanical load	30		







Document information

Symbols used

Electrical symbols



Symbol	Meaning
 A0011197	Direct current A terminal to which DC voltage is applied or through which direct current flows.
 A0011198	Alternating current A terminal to which alternating voltage is applied or through which alternating current flows.
 A0017381	Direct current and alternating current <ul style="list-style-type: none"> ■ A terminal to which alternating voltage or DC voltage is applied. ■ A terminal through which alternating current or direct current flows.
 A0011200	Ground connection A grounded terminal which, as far as the operator is concerned, is grounded via a grounding system.
 A0011199	Protective ground connection A terminal which must be connected to ground prior to establishing any other connections.
 A0011201	Equipotential connection A connection that has to be connected to the plant grounding system: This may be a potential equalization line or a star grounding system depending on national or company codes of practice.

Symbols for certain types of information

Symbol	Meaning
 A0011182	Allowed Indicates procedures, processes or actions that are allowed.
 A0011183	Preferred Indicates procedures, processes or actions that are preferred.
 A0011184	Forbidden Indicates procedures, processes or actions that are forbidden.
 A0011193	Tip Indicates additional information.
 A0011194	Reference to documentation Refers to the corresponding device documentation.
 A0011195	Reference to page Refers to the corresponding page number.
 A0011196	Reference to graphic Refers to the corresponding graphic number and page number.

Symbols in graphics

Symbol	Meaning
1, 2, 3, ...	Item numbers
1., 2., 3., ...	Series of steps
A, B, C, ...	Views
A-A, B-B, C-C, ...	Sections
 A0013441	Flow direction

Symbol	Meaning
 A0011187	Hazardous area Indicates a hazardous area.
 A0011188	Safe area (non-hazardous area) Indicates a non-hazardous area.

Function and system design

Measuring principle

Following *Faraday's law of magnetic induction*, a voltage is induced in a conductor moving through a magnetic field.

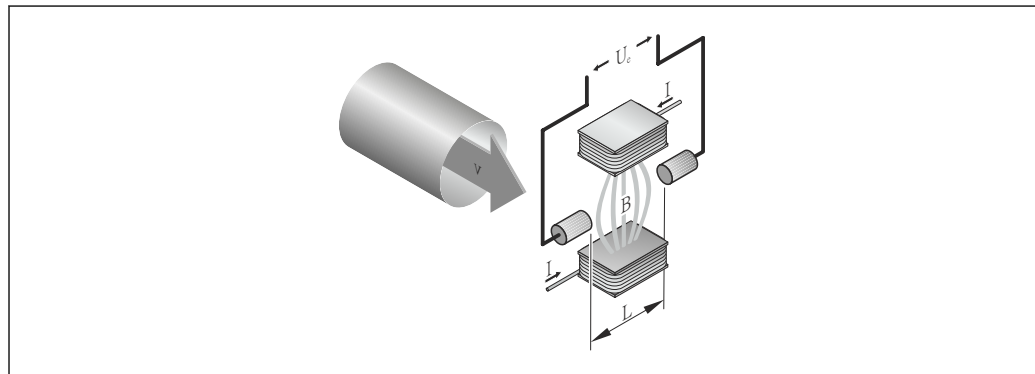

- U_e Induced voltage
 B Magnetic induction (magnetic field)
 L Electrode spacing
 I Current
 v Flow velocity

In the electromagnetic measuring principle, the flowing medium is the moving conductor. The voltage induced (U_e) is proportional to the flow velocity (v) and is supplied to the amplifier by means of two measuring electrodes. The flow volume (Q) is calculated via the pipe cross-section (A). The DC magnetic field is created through a switched direct current of alternating polarity.

Formulae for calculation

- Induced voltage $U_e = B \cdot L \cdot v$
- Volume flow $Q = A \cdot v$

Measuring system

The device consists of a transmitter and a sensor.

Two device versions are available:

- Compact version - the transmitter and sensor form a mechanical unit.
- Remote version – the transmitter and sensor are mounted separately from one another.

Transmitter

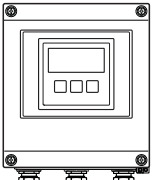
<p>Promag 400</p>  <p style="text-align: right; font-size: small;">A0017117</p>	<p>Device versions and materials</p> <ul style="list-style-type: none"> ■ Compact version: compact housing <ul style="list-style-type: none"> - Polycarbonate plastic - Coated aluminum AlSi10Mg ■ Remote version: wall-mount housing <ul style="list-style-type: none"> - Polycarbonate plastic - Coated aluminum AlSi10Mg <p>Configuration:</p> <ul style="list-style-type: none"> ■ External operation via four-line, illuminated local display with touch control and guided menus ("Make-it-run" wizards) for applications ■ Via operating tools (e.g. FieldCare) ■ Via Web browser (e.g. Microsoft Internet Explorer) ■ Also for device version with EtherNet/IP output: <ul style="list-style-type: none"> - Via Add-on Profile Level 3 for automation system from Rockwell Automation - Via Electronic Data Sheet (EDS)
---	--

Sensor

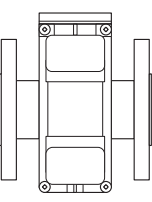
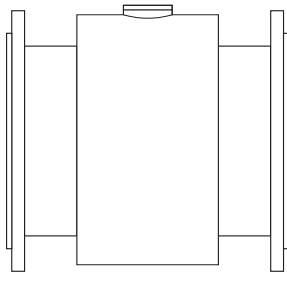
<p>Promag L</p> <p><i>Lap joint flange; lap joint flange, stamped plate: DN 50 to 300 (2 to 12")</i></p>  <p style="text-align: right; font-size: small;">A0017040</p> <p><i>Fixed flange: DN 350 to 2400 (14 to 90")</i></p>  <p style="text-align: right; font-size: small;">A0017041</p>	<p>Nominal diameter range: DN 50 to 2400 (2 to 90")</p> <p>Materials:</p> <ul style="list-style-type: none"> ■ Sensor housing: coated aluminum AlSi10Mg, carbon steel with protective varnish ■ Sensor connection housing: coated aluminum AlSi10Mg ■ Measuring tube: stainless steel 1.4301 (304), 1.4306 (304L), 202, 304 ■ Liner: hard rubber, polyurethane, PTFE ■ Seals: as per DIN EN 1514-1 ■ Electrodes: 1.4435 (304L), Alloy C22 ■ Ground disks: 1.4435 (316L), Alloy C22
--	---

Safety

IT security

We only provide a warranty if the device is installed and used as described in the Operating Instructions. The device is equipped with security mechanisms to protect it against any inadvertent changes to the device settings.

IT security measures in line with operators' security standards and designed to provide additional protection for the device and device data transfer must be implemented by the operators themselves.

Endress+Hauser can be contacted to provide support in performing this task.

Input

Measured variable

Direct measured variables

- Volume flow (proportional to induced voltage)
- Electrical conductivity

Calculated measured variables

Mass flow

Measuring range

Typically $v = 0.01$ to 10 m/s (0.03 to 33 ft/s) with the specified accuracy

Electrical conductivity: 5 to $10\,000$ $\mu\text{S}/\text{cm}/\text{cm}$

Flow characteristic values in SI units



Nominal diameter		Recommended flow min./max. full scale value ($v \sim 0.3/10$ m/s)	Factory settings		
[mm]	[in]		Full scale value current output ($v \sim 2.5$ m/s)	Pulse value (~ 2 pulse/s)	Low flow cut off ($v \sim 0.04$ m/s)
		[m ³ /h]	[m ³ /h]	[m ³]	[m ³ /h]
50	2	35 to 1 100 dm ³ /min	300 dm ³ /min	2.5 dm ³	5 dm ³ /min
65	–	60 to 2 000 dm ³ /min	500 dm ³ /min	5 dm ³	8 dm ³ /min
80	3	90 to 3 000 dm ³ /min	750 dm ³ /min	5 dm ³	12 dm ³ /min
100	4	145 to 4 700 dm ³ /min	1 200 dm ³ /min	10 dm ³	20 dm ³ /min
125	–	220 to 7 500 dm ³ /min	1 850 dm ³ /min	15 dm ³	30 dm ³ /min
150	6	20 to 600	150	0.025	2.5
200	8	35 to 1 100	300	0.05	5
250	10	55 to 1 700	500	0.05	7.5
300	12	80 to 2 400	750	0.1	10
350	14	110 to 3 300	1 000	0.1	15
375	15	140 to 4 200	1 200	0.15	20
400	16	140 to 4 200	1 200	0.15	20
450	18	180 to 5 400	1 500	0.25	25
500	20	220 to 6 600	2 000	0.25	30
600	24	310 to 9 600	2 500	0.3	40
700	28	420 to 13 500	3 500	0.5	50
750	30	480 to 15 000	4 000	0.5	60
800	32	550 to 18 000	4 500	0.75	75
900	36	690 to 22 500	6 000	0.75	100
1 000	40	850 to 28 000	7 000	1	125
–	42	950 to 30 000	8 000	1	125
1 200	48	1 250 to 40 000	10 000	1.5	150
–	54	1 550 to 50 000	13 000	1.5	200
1 400	–	1 700 to 55 000	14 000	2	225
–	60	1 950 to 60 000	16 000	2	250
1 600	–	2 200 to 70 000	18 000	2.5	300
–	66	2 500 to 80 000	20 500	2.5	325
1 800	72	2 850 to 90 000	23 000	3	350

Nominal diameter		Recommended flow min./max. full scale value (v ~ 0.3/10 m/s)	Factory settings		
[mm]	[in]		Full scale value current output (v ~ 2.5 m/s)	Pulse value (~ 2 pulse/s)	Low flow cut off (v ~ 0.04 m/s)
		[m ³ /h]	[m ³ /h]	[m ³]	[m ³ /h]
-	78	3 300 to 100 000	28 500	3.5	450
2 000	-	3 400 to 110 000	28 500	3.5	450
-	84	3 700 to 125 000	31 000	4.5	500
2 200	-	4 100 to 136 000	34 000	4.5	540
-	90	4 300 to 143 000	36 000	5	570
2 400	-	4 800 to 162 000	40 000	5.5	650

Flow characteristic values in US units

Nominal diameter		Recommended flow min./max. full scale value (v ~ 0.3/10 m/s)	Factory settings		
[in]	[mm]		Full scale value current output (v ~ 2.5 m/s)	Pulse value (~ 2 pulse/s)	Low flow cut off (v ~ 0.04 m/s)
		[gal/min]	[gal/min]	[gal]	[gal/min]
1	25	2.5 to 80	18	0.2	0.25
1 ½	40	7 to 190	50	0.5	0.75
2	50	10 to 300	75	0.5	1.25
-	65	16 to 500	130	1	2
3	80	24 to 800	200	2	2.5
4	100	40 to 1 250	300	2	4
8	200	155 to 4 850	1 200	10	15
10	250	250 to 7 500	1 500	15	30
12	300	350 to 10 600	2 400	25	45
14	350	500 to 15 000	3 600	30	60
15	375	600 to 19 000	4 800	50	60
16	400	600 to 19 000	4 800	50	60
18	450	800 to 24 000	6 000	50	90
20	500	1 000 to 30 000	7 500	75	120
24	600	1 400 to 44 000	10 500	100	180
28	700	1 900 to 60 000	13 500	125	210
30	750	2 150 to 67 000	16 500	150	270
32	800	2 450 to 80 000	19 500	200	300
36	900	3 100 to 100 000	24 000	225	360
40	1 000	3 800 to 125 000	30 000	250	480
42	-	4 200 to 135 000	33 000	250	600
48	1 200	5 500 to 175 000	42 000	400	600
54	-	9 to 300 MGal/d	75 MGal/d	0.0005 MGal/d	1.3 MGal/d
-	1 400	10 to 340 MGal/d	85 MGal/d	0.0005 MGal/d	1.3 MGal/d
60	-	12 to 380 MGal/d	95 MGal/d	0.0005 MGal/d	1.3 MGal/d
-	1 600	13 to 450 MGal/d	110 MGal/d	0.0008 MGal/d	1.7 MGal/d

Nominal diameter		Recommended flow min./max. full scale value (v ~ 0.3/10 m/s) [gal/min]	Factory settings		
[in]	[mm]		Full scale value current output (v ~ 2.5 m/s) [gal/min]	Pulse value (~ 2 pulse/s) [gal]	Low flow cut off (v ~ 0.04 m/s) [gal/min]
66	-	14 to 500 MGal/d	120 MGal/d	0.0008 MGal/d	2.2 MGal/d
72	1 800	16 to 570 MGal/d	140 MGal/d	0.0008 MGal/d	2.6 MGal/d
78	-	18 to 650 MGal/d	175 MGal/d	0.0010 MGal/d	3.0 MGal/d
-	2 000	20 to 700 MGal/d	175 MGal/d	0.0010 MGal/d	2.9 MGal/d
84	-	24 to 800 MGal/d	190 MGal/d	0.0011 MGal/d	3.2 MGal/d
-	2 200	26 to 870 MGal/d	210 MGal/d	0.0012 MGal/d	3.4 MGal/d
90	-	27 to 910 MGal/d	220 MGal/d	0.0013 MGal/d	3.6 MGal/d
-	2 400	31 to 1 030 MGal/d	245 MGal/d	0.0014 MGal/d	4.1 MGal/d

 To calculate the measuring range, use the *Applicator* sizing tool (→  66)

Recommended measuring range

"Flow limit" section (→  34)

Operable flow range

Over 1000 : 1

Input signal

Status input

Maximum input values	<ul style="list-style-type: none"> ▪ DC 30 V ▪ 6 mA
Response time	Adjustable: 5 to 200 ms
Input signal level	<ul style="list-style-type: none"> ▪ Low signal: DC -3 to +5 V ▪ High signal: DC 12 to 30 V
Assignable functions	<ul style="list-style-type: none"> ▪ Off ▪ Reset totalizers 1-3 separately ▪ Reset all totalizers ▪ Flow override

Output

Output signal

Current output

Current output	Can be set as: <ul style="list-style-type: none"> ▪ 4-20 mA NAMUR ▪ 4-20 mA US ▪ 4-20 mA HART ▪ 0-20 mA
Maximum output values	<ul style="list-style-type: none"> ▪ DC 24 V (when idle) ▪ 22.5 mA
Load	0 to 700 Ω
Resolution	0.5 μA

Damping	Adjustable: 0.07 to 999 s
Assignable measured variables	<ul style="list-style-type: none"> ▪ Volume flow ▪ Mass flow ▪ Flow velocity ▪ Conductivity ▪ Electronics temperature

Pulse/frequency/switch output

Function	<ul style="list-style-type: none"> ▪ With the order code for "Output; Input", option H: output 2 can be set as a pulse or frequency output ▪ With the order code for "Output; Input", option I: output 2 and 3 can be set as a pulse, frequency or switch output
Version	Passive, open collector
Maximum input values	<ul style="list-style-type: none"> ▪ DC30 V ▪ 250 mA
Voltage drop	For 25 mA: ≤ DC2 V
Pulse output	
Pulse width	Adjustable: 0.05 to 2 000 ms
Maximum pulse rate	10 000 Impulse/s
Pulse value	Adjustable
Assignable measured variables	<ul style="list-style-type: none"> ▪ Volume flow ▪ Mass flow
Frequency output	
Output frequency	Adjustable: 0 to 12 500 Hz
Damping	Adjustable: 0 to 999 s
Pulse/pause ratio	1:1
Assignable measured variables	<ul style="list-style-type: none"> ▪ Volume flow ▪ Mass flow ▪ Flow velocity ▪ Conductivity ▪ Electronics temperature
Switch output	
Switching behavior	Binary, conductive or non-conductive
Switching delay	Adjustable: 0 to 100 s
Number of switching cycles	Unlimited
Assignable functions	<ul style="list-style-type: none"> ▪ Off ▪ On ▪ Diagnostic behavior ▪ Limit value: <ul style="list-style-type: none"> - Off - Volume flow - Mass flow - Flow velocity - Conductivity - Totalizer 1-3 - Electronics temperature ▪ Flow direction monitoring ▪ Status <ul style="list-style-type: none"> - Empty pipe detection - Low flow cut off

EtherNet/IP

Standards	In accordance with IEEE 802.3
------------------	-------------------------------

Signal on alarm

Depending on the interface, failure information is displayed as follows:

Current output*4-20 mA*

Failure mode	Selectable (as per NAMUR recommendation NE 43): <ul style="list-style-type: none"> ■ Minimum value: 3.6 mA ■ Maximum value: 22 mA ■ Defined value: 3.59 to 22.5 mA ■ Actual value ■ Last valid value
---------------------	---

0-20 mA

Failure mode	Choose from: <ul style="list-style-type: none"> ■ Maximum alarm: 22 mA ■ Defined value: 0 to 22.5 mA
---------------------	--

HART

Device diagnostics	Device condition can be read out via HART Command 48
---------------------------	--

Pulse/frequency/switch output

Pulse output	
Failure mode	Choose from: <ul style="list-style-type: none"> ■ Actual value ■ No pulses
Frequency output	
Failure mode	Choose from: <ul style="list-style-type: none"> ■ Actual value ■ Defined value: 0 to 12 500 Hz ■ 0 Hz
Switch output	
Failure mode	Choose from: <ul style="list-style-type: none"> ■ Current status ■ Open ■ Closed

EtherNet/IP

Device diagnostics	Device condition can be read out in Input Assembly
---------------------------	--

Local display

Plain text display	With information on cause and remedial measures
Backlight	Red backlighting indicates a device error.





Status signal as per NAMUR recommendation NE 107

Operating tool

- Via digital communication:
HART protocol
- Via service interface

Plain text display	With information on cause and remedial measures
---------------------------	---

 Additional information on remote operation (→  62)

Web browser

Plain text display	With information on cause and remedial measures
---------------------------	---

Light emitting diodes (LED)

Status information	<p>Status indicated by various light emitting diodes</p> <p>The following information is displayed depending on the device version:</p> <ul style="list-style-type: none"> ▪ Supply voltage active ▪ Data transmission active ▪ Device alarm/error has occurred ▪ EtherNet/IP network available ▪ EtherNet/IP connection established
---------------------------	---

Low flow cut off The switch points for low flow cut off are user-selectable.

Galvanic isolation The following connections are galvanically isolated from each other:

- Inputs
- Outputs
- Power supply

Protocol-specific data HART

Manufacturer ID	0x11
Device type ID	0x67
HART protocol revision	6.0
Device description files (DTM, DD)	Information and files under: www.endress.com
HART load	Min. 250 Ω
Dynamic variables	<p>The measured variables can be freely assigned to the dynamic variables.</p> <p>Measured variables for PV (primary dynamic variable)</p> <ul style="list-style-type: none"> ▪ Off ▪ Volume flow ▪ Mass flow ▪ Flow velocity ▪ Electronics temperature <p>Measured variables for SV, TV, QV (secondary, tertiary and quaternary dynamic variable)</p> <ul style="list-style-type: none"> ▪ Volume flow ▪ Mass flow ▪ Flow velocity ▪ Conductivity ▪ Electronics temperature ▪ Totalizer 1 ▪ Totalizer 2 ▪ Totalizer 3

EtherNet/IP

Protocol	<ul style="list-style-type: none"> ▪ The CIP Networks Library Volume 1: Common Industrial Protocol ▪ The CIP Networks Library Volume 2: EtherNet/IP Adaptation of CIP 		
Communication type	<ul style="list-style-type: none"> ▪ 10Base-T ▪ 100Base-TX 		
Device profile	Generic device (product type: 0x2B)		
Manufacturer ID	0x49E		
Device type ID	0x1067		
Baud rates	Automatic ¹⁹ / ₁₀₀ Mbit with half-duplex and full-duplex detection		
Polarity	Auto-polarity for automatic correction of crossed TxD and RxD pairs		
Supported CIP connections	Max. 3 connections		
Explicit connections	Max. 6 connections		
I/O connections	Max. 6 connections (scanner)		
Configuration options for measuring device	<ul style="list-style-type: none"> ▪ DIP switches on the electronics module for IP addressing ▪ Manufacturer-specific software (FieldCare) ▪ Add-on Profile Level 3 for Rockwell Automation control systems ▪ Web browser ▪ Electronic Data Sheet (EDS) integrated in the measuring device 		
Configuration of the EtherNet interface	<ul style="list-style-type: none"> ▪ Speed: 10 MBit, 100 MBit, auto (factory setting) ▪ Duplex: half-duplex, full-duplex, auto (factory setting) 		
Configuration of the device address	<ul style="list-style-type: none"> ▪ DIP switches on the electronics module for IP addressing (last octet) ▪ DHCP ▪ Manufacturer-specific software (FieldCare) ▪ Add-on Profile Level 3 for Rockwell Automation control systems ▪ Web browser ▪ EtherNet/IP tools, e.g. RSLinx (Rockwell Automation) 		
Device Level Ring (DLR)	No		
Fix Input			
RPI	5 ms to 10 s (factory setting: 20 ms)		
Exclusive Owner Multicast		Instance	Size [byte]
	Instance configuration:	0x68	398
	O → T configuration:	0x66	56
	T → O configuration:	0x64	32
Exclusive Owner Multicast		Instance	Size [byte]
	Instance configuration:	0x69	-
	O → T configuration:	0x66	56
	T → O configuration:	0x64	32
Input only Multicast		Instance	Size [byte]
	Instance configuration:	0x68	398
	O → T configuration:	0xC7	-
	T → O configuration:	0x64	32
Input only Multicast		Instance	Size [byte]
	Instance configuration:	0x69	-
	O → T configuration:	0xC7	-
	T → O configuration:	0x65	32

Input Assembly	<ul style="list-style-type: none"> ■ Current device diagnostics ■ Volume flow ■ Mass flow ■ Temperature ■ Totalizer 1 ■ Totalizer 2 ■ Totalizer 3 		
Configurable Input			
RPI	5 ms to 10 s (factory setting: 20 ms)		
Exclusive Owner Multicast		Instance	Size [byte]
	Instance configuration:	0x68	398
	O → T configuration:	0x66	56
	T → O configuration:	0x65	88
Exclusive Owner Multicast		Instance	Size [byte]
	Instance configuration:	0x69	-
	O → T configuration:	0x66	56
	T → O configuration:	0x64	88
Input only Multicast		Instance	Size [byte]
	Instance configuration:	0x68	398
	O → T configuration:	0xC7	-
	T → O configuration:	0x64	88
Input only Multicast		Instance	Size [byte]
	Instance configuration:	0x69	-
	O → T configuration:	0xC7	-
	T → O configuration:	0x65	88
Configurable Input Assembly	<ul style="list-style-type: none"> ■ Volume flow ■ Temperature ■ Mass flow ■ Totalizer 1 to 3 ■ Flow velocity ■ Volume flow unit ■ Temperature unit ■ Mass flow unit ■ Unit totalizer 1-3 ■ Flow velocity unit 		
Fix Output			
Output Assembly	<ul style="list-style-type: none"> ■ Activation of reset totalizers 1-3 ■ Activation of reference density compensation ■ Reset totalizers 1-3 ■ External density ■ Density unit ■ Temperature unit 		

Configuration	
Configuration Assembly	<p>Only the most common configurations are listed below.</p> <ul style="list-style-type: none"> ▪ Software write protection ▪ Mass flow unit ▪ Mass unit ▪ Volume flow unit ▪ Volume unit ▪ Density unit ▪ Reference density unit ▪ Temperature unit ▪ Length ▪ Totalizer 1-3: <ul style="list-style-type: none"> - Assignment - Unit - Operating mode - Failure mode ▪ Alarm delay

Power supply

Terminal assignment

Transmitter

0-20 mA/4-20 mA HART connection version with additional outputs and inputs

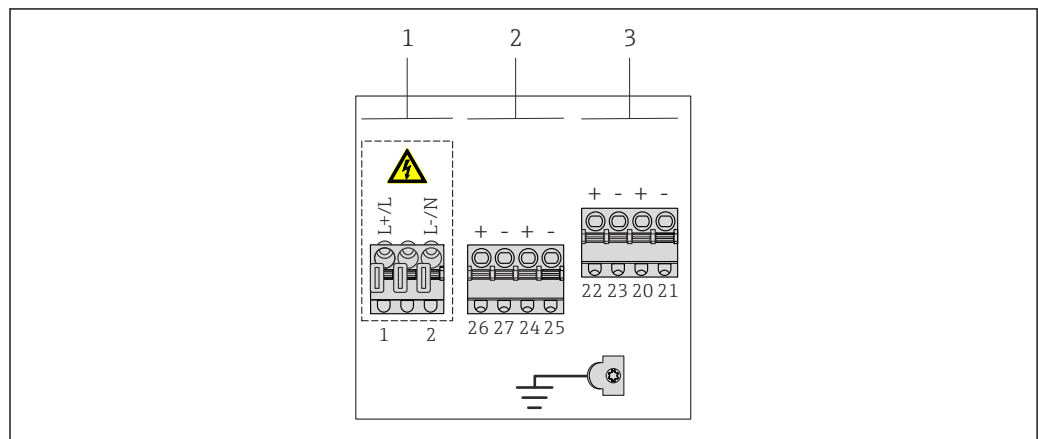

A0020424

- 1 Supply voltage
- 2 Output 1 (26/27) and output 2 (24/25)
- 3 Output 3 (22/23) and input 1 (20/21)

Supply voltage

Order code for "Power supply"	Terminal numbers	
	1 (L+/L)	2 (L-/N)
Option L (wide range power unit)	AC100 to 240 V	
	AC/DC24 V	

Signal transmission 0-20 mA/4-20 mA HART with additional outputs and inputs

Order code for "Output" and "Input"	Terminal numbers							
	Output 1		Output 2		Output 3		Input	
	26 (+)	27 (-)	24 (+)	25 (-)	22 (+)	23 (-)	20 (+)	21 (-)
Option H	<ul style="list-style-type: none"> 4-20 mA HART (active) 0-20 mA (active) 		Pulse/frequency output (passive)		Switch output (passive)		-	
Option I	<ul style="list-style-type: none"> 4-20 mA HART (active) 0-20 mA (active) 		Pulse/frequency/switch output (passive)		Pulse/frequency/switch output (passive)		Status input	

EtherNet/IP connection version

The sensor can be ordered with terminals or a device plug.

Connection methods available		Possible options for order code "Electrical connection"
Outputs	Power supply	
Terminals	Terminals	<ul style="list-style-type: none"> Option A: coupling M20x1 Option B: thread M20x1 Option C: thread G 1/2" Option D: thread NPT 1/2"
Device plug (→ 16)	Terminals	<ul style="list-style-type: none"> Option L: plug M12x1 + thread NPT 1/2" Option N: plug M12x1 + coupling M20 Option P: plug M12x1 + thread G 1/2" Option U: plug M12x1 + thread M20

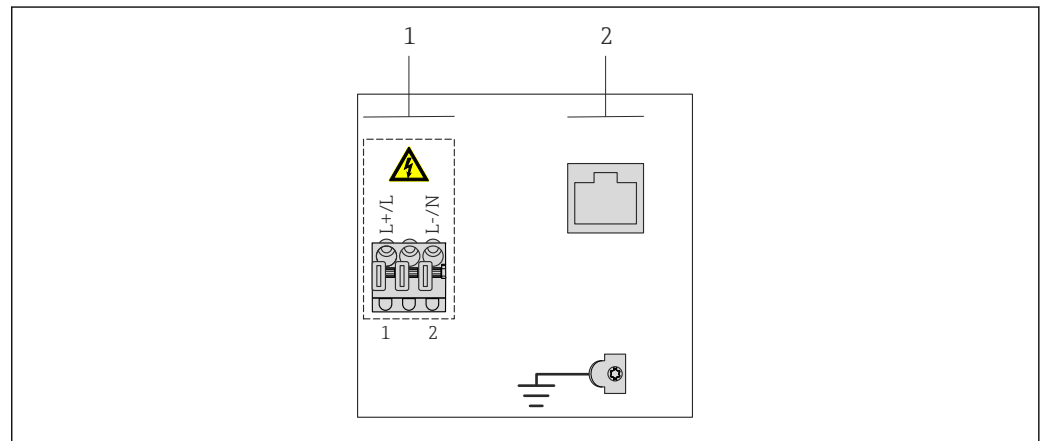

A0020428

- 1 Supply voltage (wide range power unit)
- 2 EtherNet/IP

Supply voltage

Order code for "Power supply"	Terminal numbers	
	1 (L+/L)	2 (L-/N)
Option L (wide range power unit)	AC100 to 240 V	
	AC/DC24 V	

EtherNet/IP signal transmission

Order code for "Output"	Connection via
Option N	EtherNet/IP connector

Remote version

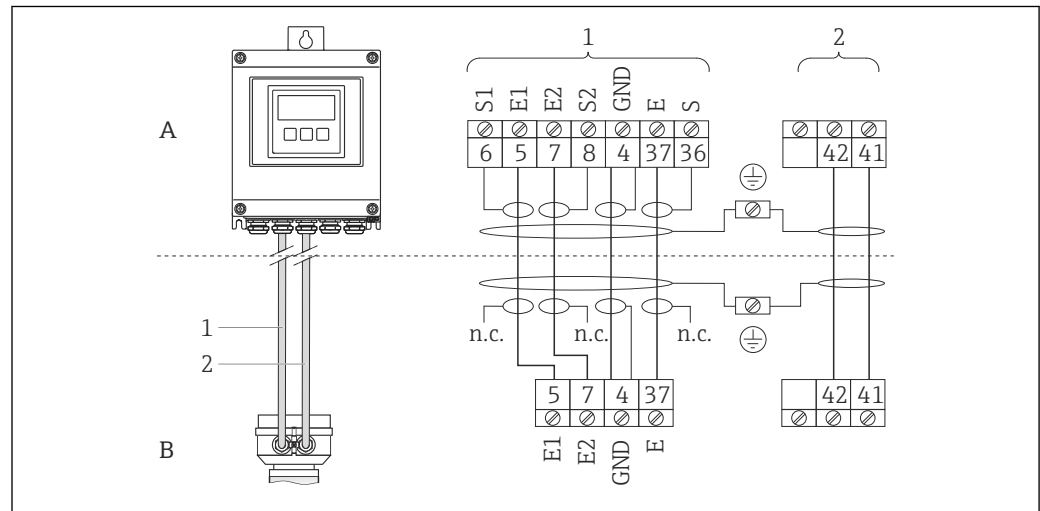

1 Remote version terminal assignment

- A Transmitter wall-mount housing
- B Sensor connection housing
- 1 Electrode cable
- 2 Coil current cable
- n.c. Not connected, insulated cable shields

Terminal No. and cable colors: 6/5 = brown; 7/8 = white; 4 = green; 36/37 = yellow

Pin assignment, device plug

i Order codes for the M12x1 plug, see the "Order code for electrical connection" column: EtherNet/IP (→ 15)

EtherNet/IP

EtherNet/IP (on the device side)

	Pin	Assignment	Coding	Plug/socket
	1	+	Tx	D
2	+	Rx		
3	-	Tx		
4	-	Rx		

- i** Recommended plug:
 - Binder, series 763, part no. 99 3729 810 04
 - Phoenix, part no. 1543223 SACC-M12MSD-4Q
 - When using the device in a hazardous location: Use a suitably certified plug.

Supply voltage

Transmitter

Order code for "Power supply"	Terminal voltage	Frequency range
Option L	AC100 to 240 V	50/ 60 Hz, ±4 Hz
	AC/DC24 V	50/ 60 Hz, ±4 Hz

Power consumption	Order code for "Output"	Maximum Power consumption
	Option L	30 VA/8 W
	Option N	30 VA/8 W

Current consumption	Transmitter		
	Order code for "Power supply"	Maximum Current consumption	Maximum switch-on current
	Option L: AC 100 to 240 V	145 mA	25 A (< 5 ms)
Option L: AC/DC 24 V	350 mA	27 A (< 5 ms)	

- Power supply failure**
- Totalizers stop at the last value measured.
 - Configuration is retained in the plug-in memory (HistoROM DAT).
 - Error messages (incl. total operated hours) are stored.

Electrical connection **Connecting the transmitter**

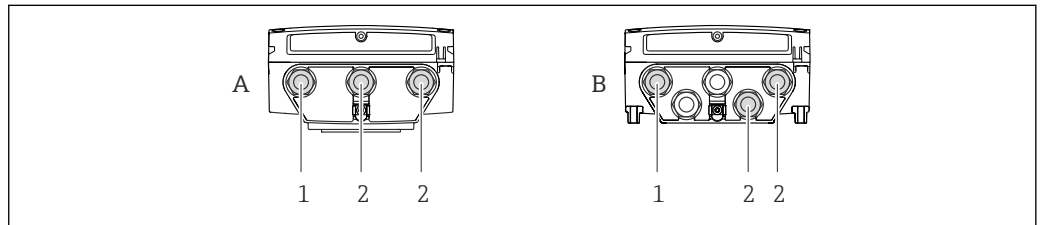

2 Supply voltage and signal transmission connection

- A Compact version
- B Remote version wall-mount housing
- 1 Cable entry for supply voltage
- 2 Cable entry for signal transmission

Remote version connection

Connecting cable

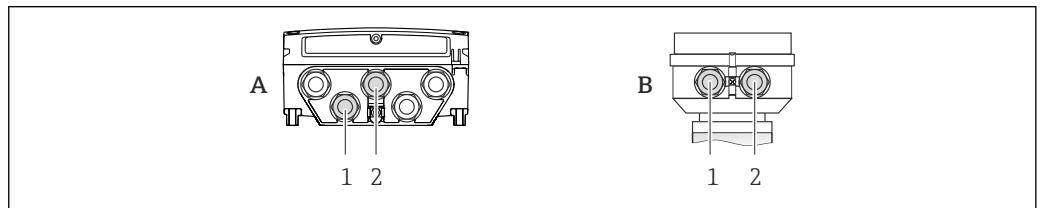

3 Connecting cable connection: electrode and coil current cable

- A Transmitter wall-mount housing
- B Sensor connection housing
- 1 Electrode cable
- 2 Coil current cable

- Fix the cable run or route it in an armored conduit. Cable movements can influence the measuring signal especially in the case of low fluid conductivities.
- Route the cable well clear of electrical machines and switching elements.
- Ensure potential equalization between sensor and transmitter (→ 19).

Connection examples

Current output 4-20 mA HART

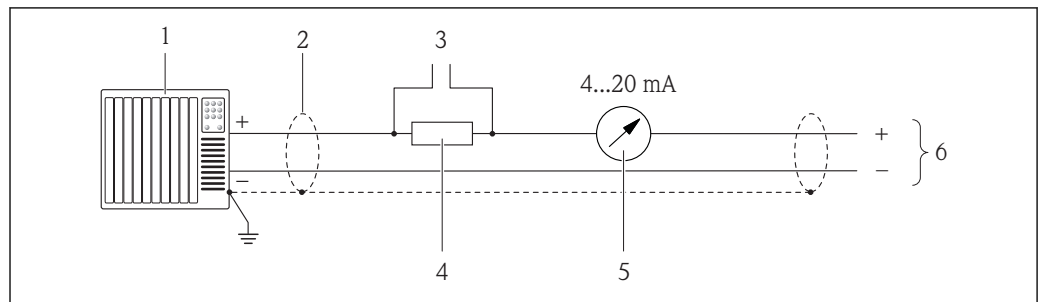

4 Connection example for 4-20 mA HART current output (active)

- 1 Automation system with current input (e.g. PLC)
- 2 Cable shield, observe cable specifications (→ 22)
- 3 Connection for HART operating devices (→ 62)
- 4 Resistor for HART communication ($\geq 250 \Omega$): observe maximum load (→ 8)
- 5 Analog display unit: observe maximum load (→ 8)
- 6 Transmitter

Current output 4-20 mA

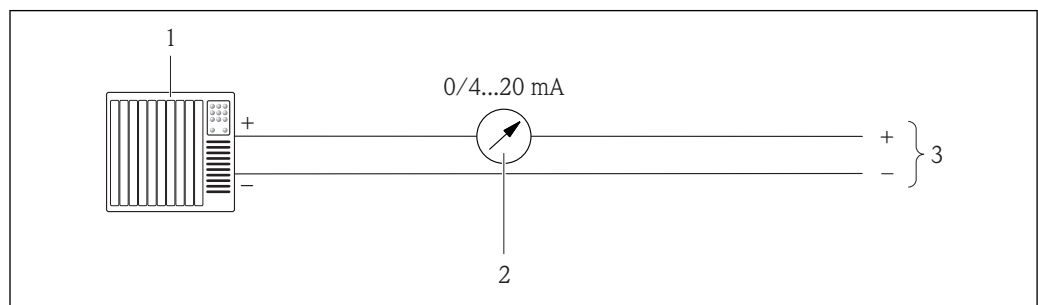

5 Connection example for 0-20 mA current output (active) and 4-20 mA current output (active)

- 1 Automation system with current input (e.g. PLC)
- 2 Analog display unit: observe maximum load (→ 8)
- 3 Transmitter

Pulse/frequency output

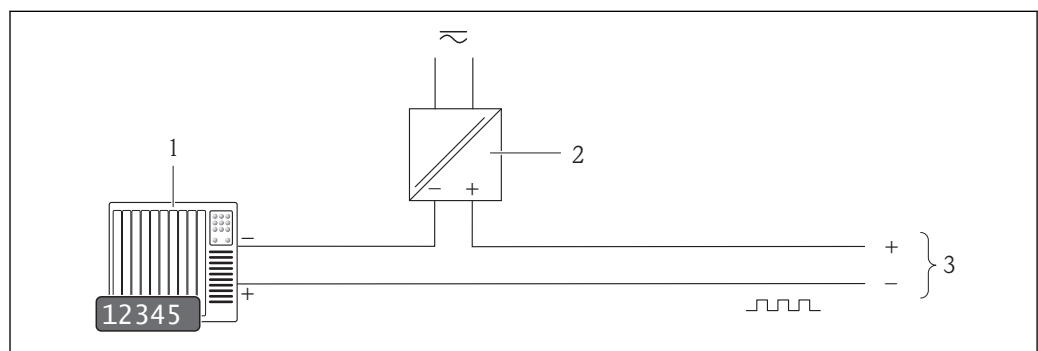

6 Connection example for pulse/frequency output (passive)

- 1 Automation system with pulse/frequency input (e.g. PLC)
- 2 Power supply
- 3 Transmitter: observe input values (→ 9)

EtherNet/IP

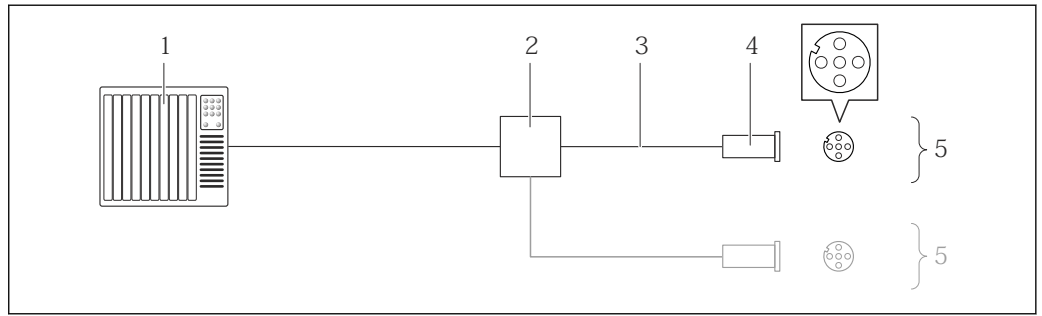

A0016805

7 Connection example for EtherNet/IP

- 1 Control system (e.g. PLC)
- 2 Ethernet switch
- 3 Observe cable specifications (→ 22)
- 4 Device plug
- 5 Transmitter

Status input

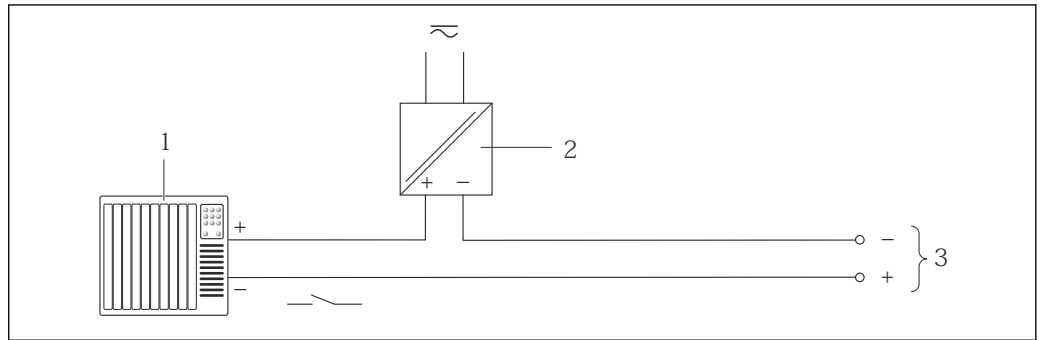

A0017163

8 Connection example for status input

- 1 Automation system with status output (e.g. PLC)
- 2 Power supply
- 3 Transmitter: observe input values

Potential equalization

Requirements

Please consider the following to ensure correct measurement:

- Same electrical potential for the fluid and sensor
- Company-internal grounding concepts
- Pipe material and grounding

Connection examples for standard situations

Metal, grounded pipe

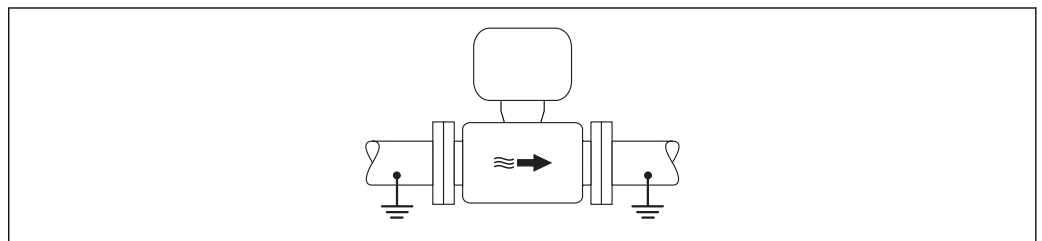

A0016315

9 Potential equalization via measuring tube

Connection example in special situations

Unlined and ungrounded metal pipe

This connection method also applies in situations where:

- The customary potential equalization is not used
- Equalizing currents are present

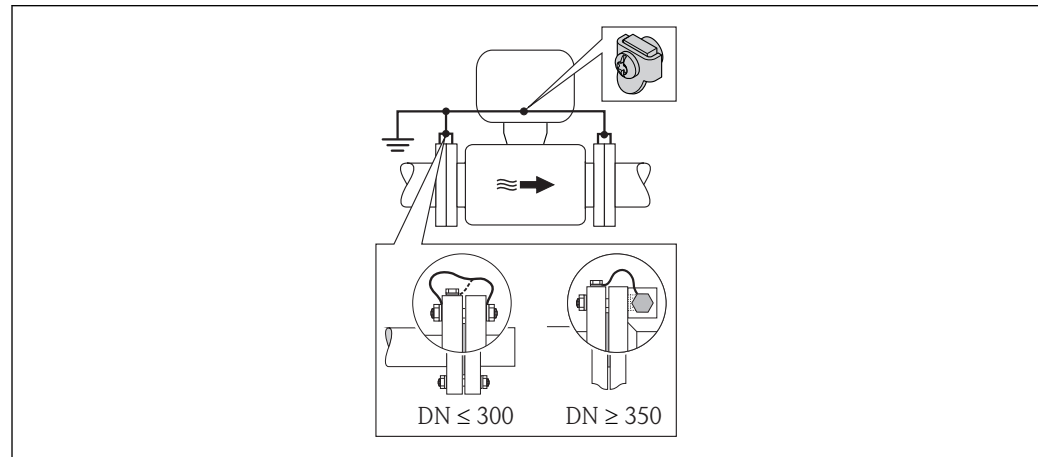

A0016317

10 Potential equalization via ground terminal and pipe flanges

Note the following when installing:

- Connect both sensor flanges to the pipe flange via a ground cable and ground them.
- Connect the connection housing of the transmitter or sensor to ground potential by means of the ground terminal provided for the purpose. To mount the ground cable:
 - If $DN \leq 300$ (12"): Mount the ground cable directly on the conductive flange coating of the sensor with the flange screws.
 - If $DN \geq 350$ (14"): Mount the ground cable directly on the metal transport bracket.

Ground cable	Copper wire, at least 6 mm^2 (0.0093 in ²)
---------------------	--

i For remote device versions, the ground terminal in the example always refers to the sensor and **not** to the transmitter.

i The necessary ground cable can be ordered from Endress+Hauser .

Plastic pipe or pipe with insulating liner

This connection method also applies in situations where:

- The customary potential equalization is not used
- Equalizing currents are present

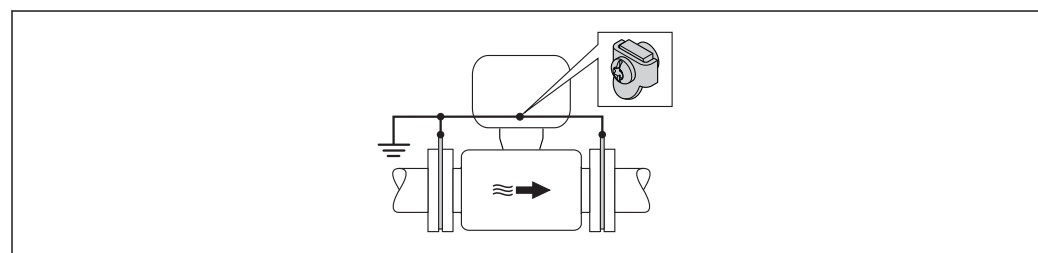



A0016318

11 Potential equalization via ground terminal and ground disks

Note the following when installing:

The ground disks must be connected to the ground terminal via the ground cable and be connected to ground potential.

Ground cable	Copper wire, at least 6 mm ² (0.0093 in ²)
---------------------	---

-  For remote device versions, the ground terminal in the example always refers to the sensor and **not** to the transmitter.
-  The ground cable and ground disks can be ordered from Endress+Hauser (→  65).

Pipe with a cathodic protection unit

This connection method is only used if the following two conditions are met:

- Metal pipe without liner or pipe with electrically conductive liner
- Cathodic protection is integrated in the personal protection equipment

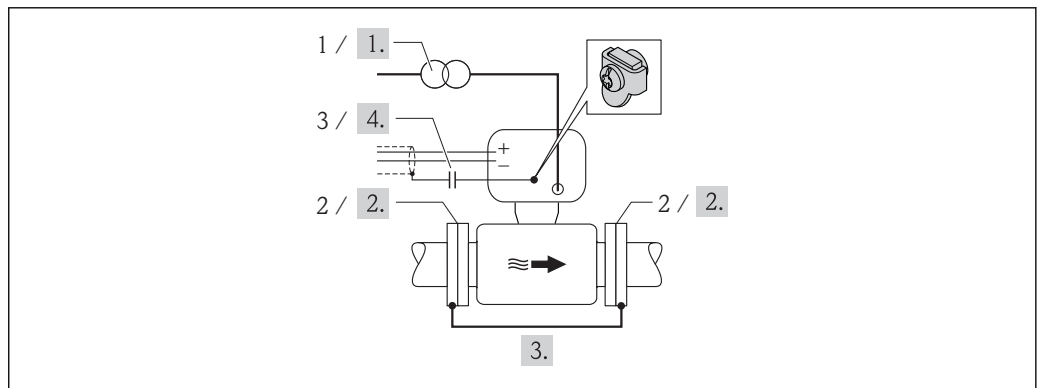



 12 Potential equalization and cathodic protection

- 1 Isolation transformer power supply
- 2 Electrically isolated from the pipe
- 3 Capacitor

Ground cable	Copper wire, at least 6 mm ² (0.0093 in ²)
---------------------	---

1. Connect the measuring device to the power supply such that it is floating in relation to the protective ground.
2. Install the sensor in the pipe in a way that provides electrical insulation.
3. Connect the two flanges of the pipe to one another via a ground cable.
4. Guide the shield of the signal lines through a capacitor.

-  For remote device versions, the ground terminal in the example always refers to the sensor and **not** to the transmitter.
-  The necessary ground cable can be ordered from Endress+Hauser .

Terminals

Transmitter

- Supply voltage cable: plug-in spring terminals for wire cross-sections 0.5 to 2.5 mm² (20 to 14 AWG)
- Signal cable: plug-in spring terminals for wire cross-sections 0.5 to 2.5 mm² (20 to 14 AWG)
- Electrode cable: spring terminals for wire cross-sections 0.5 to 2.5 mm² (20 to 14 AWG)
- Coil current cable: spring terminals for wire cross-sections 0.5 to 2.5 mm² (20 to 14 AWG)

Sensor connection housing

Spring terminals for wire cross-sections 0.5 to 2.5 mm² (20 to 14 AWG)

Cable entries

Cable entry thread

- M20 x 1.5
- Via adapter:
 - NPT ½"
 - G ½"

Cable gland

- For standard cable: M20 × 1.5 with cable ϕ 6 to 12 mm (0.24 to 0.47 in)
- For reinforced cable: M20 × 1.5 with cable ϕ 9.5 to 16 mm (0.37 to 0.63 in)



If metal cable entries are used, use a grounding plate.

Cable specification**Permitted temperature range**

- -40 °C (-40 °F) to +80 °C (+176 °F)
- Minimum requirement: cable temperature range \geq ambient temperature +20 K

Power supply cable

Standard installation cable is sufficient.

Signal cable*Current output*

- For 0-20 mA and 4-20 mA: standard installation cable is sufficient.
- For 4-20 mA HART: Shielded cable recommended. Observe grounding concept of the plant.

Pulse/frequency/switch output

Standard installation cable is sufficient.

Status input

Standard installation cable is sufficient.

EtherNet/IP

The standard ANSI/TIA/EIA-568-B.2 Annex specifies CAT 5 as the minimum category for a cable used for EtherNet/IP. CAT 5e and CAT 6 are recommended.



For more information on planning and installing EtherNet/IP networks, please refer to the "Media Planning and Installation Manual. EtherNet/IP" of the ODVA Organization.

Connecting cable for remote version*Electrode cable*

Standard cable	3 × 0.38 mm ² (20 AWG) with common, braided copper shield ($\phi \sim 7$ mm (0.28")) and individually shielded cores
Cable for empty pipe detection (EPD)	4 × 0.38 mm ² (20 AWG) with common, braided copper shield ($\phi \sim 7$ mm (0.28")) and individually shielded cores
Conductor resistance	≤ 50 Ω /km (0.015 Ω /ft)
Capacitance: core/shield	≤ 420 pF/m (128 pF/ft)
Operating temperature	-20 to +80 °C (-68 to +176 °F)

Coil current cable

Standard cable	2 × 0.75 mm ² (18 AWG) with common, braided copper shield ($\phi \sim 7$ mm (0.28")) and individually shielded cores
Conductor resistance	≤ 37 Ω /km (0.011 Ω /ft)
Capacitance: core/core, shield grounded	≤ 120 pF/m (37 pF/ft)
Operating temperature	-20 to +80 °C (-68 to +176 °F)
Test voltage for cable insulation	\leq AC 1433 V r.m.s. 50/60 Hz or \geq DC 2026 V

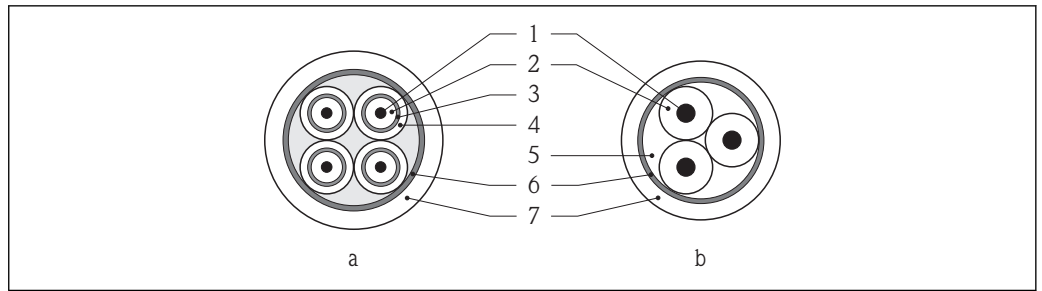

A0003194

13 Cable cross-section

- a Electrode cable
- b Coil current cable
- 1 Core
- 2 Core insulation
- 3 Core shield
- 4 Core jacket
- 5 Core reinforcement
- 6 Cable shield
- 7 Outer jacket

Reinforced connecting cable

Use in the following situations:

- When laying the cable directly in the ground
- Where there is a risk of damage from rodents

i The reinforced connecting cable with an additional, reinforcing metal braid can be ordered from Endress+Hauser .

Operation in zones of severe electrical interference

The measuring system meets the general safety requirements (→ 63) and EMC specifications (→ 30).

Grounding is by means of the ground terminal provided for the purpose inside the connection housing. The stripped and twisted lengths of cable shield to the ground terminal must be as short as possible.

Performance characteristics

Reference operating conditions

In accordance with DIN EN 29104

- Fluid temperature: $+28 \pm 2$ °C ($+82 \pm 4$ °F)
- Ambient temperature range: $+22 \pm 2$ °C ($+72 \pm 4$ °F)
- Warm-up period: 30 min

Installation

- Inlet run $> 10 \times$ DN
- Outlet run $> 5 \times$ DN
- Sensor and transmitter grounded.
- The sensor is centered in the pipe.

i To calculate the measuring range, use the *Applicator* sizing tool (→ 66)

Maximum measured error

Error limits under reference operating conditions

o.r. = of reading

Volume flow

- ± 0.5 % o.r. ± 1 mm/s (0.04 in/s)
- Optional: ± 0.2 % o.r. ± 2 mm/s (0.08 in/s)

i Fluctuations in the supply voltage do not have any effect within the specified range.

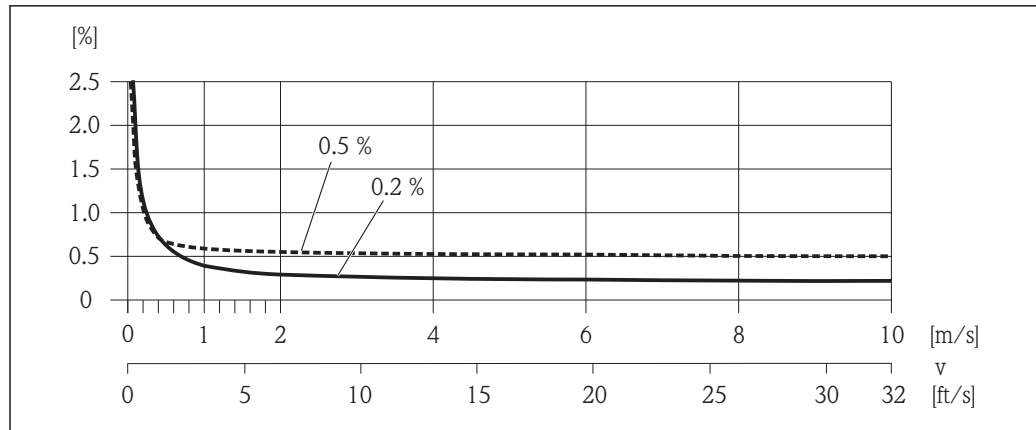

14 Maximum measured error in % o.r.

Electrical conductivity

Max. measured error not specified.

Accuracy of outputs

o.r. = of reading; o.f.s. = of full scale value

The outputs have the following base accuracy specifications.

Current output

Accuracy	Max. ± 0.025 % o.f.s. or ± 5 μA
----------	--

Pulse/frequency output

Accuracy	Max. ± 50 ppm o.r.
----------	------------------------

Repeatability

o.r. = of reading

Volume flow

Max. ± 0.1 % o.r. ± 0.5 mm/s (0.02 in/s)

Electrical conductivity

Max. ± 5 % o.r.

Influence of ambient temperature

o.r. = of reading; o.f.s. = of full scale value

Current output

Temperature coefficient	Typically ± 50 ppm/ $^{\circ}\text{C}$ o.r. or ± 1 $\mu\text{A}/^{\circ}\text{C}$
-------------------------	---

Pulse/frequency output

Temperature coefficient	Max. ± 0.5 ppm v.M./ $^{\circ}\text{C}$
-------------------------	---

Installation

No special measures such as supports are necessary. External forces are absorbed by the construction of the device.

Mounting location

Preferably install the sensor in an ascending pipe, and ensure a sufficient distance to the next pipe elbow: $h \geq 2 \times \text{DN}$

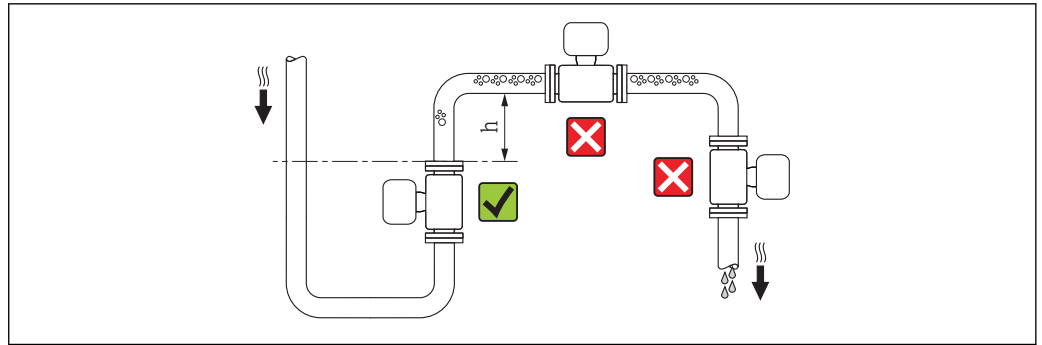

A0017061

To prevent measuring errors arising from accumulation of gas bubbles in the measuring tube, avoid the following mounting locations in the pipe:

- Highest point of a pipeline.
- Directly upstream of a free pipe outlet in a down pipe.

Installation in down pipes

Install a siphon or a vent valve downstream of the sensor in down pipes whose length $h \geq 5 \text{ m}$ (16.4 ft). This precaution is to avoid low pressure and the consequent risk of damage to the measuring tube. This measure also prevents the system losing prime, which could cause air pockets.

 For information on the liner's resistance to partial vacuum (\rightarrow  33)

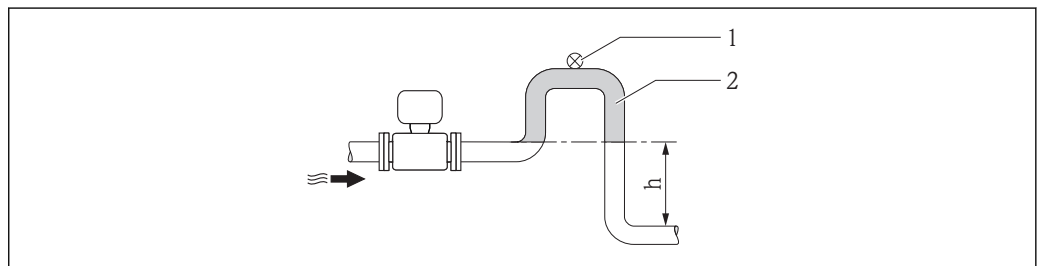

A0017064

15 Installation in a down pipe

- 1 Vent valve
- 2 Pipe siphon
- h Length of down pipe

Installation in partially filled pipes

A partially filled pipe with a gradient necessitates a drain-type configuration. The empty pipe detection (EPD) function offers additional protection by detecting empty or partially filled pipes.

- Do not install the sensor at the lowest point in the drain: risk of solids accumulating.
- It is advisable to install a cleaning valve.

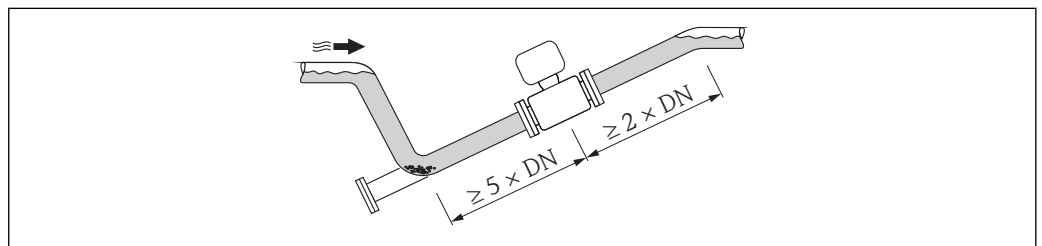

A0017063

For very heavy sensors

If the nominal diameter $DN \geq 350$ (14 in), mount the sensor on a foundation of adequate load-bearing strength.

Do not support the weight of the sensor on the metal casing as this could damage the metal casing and the internal magnetic coils.

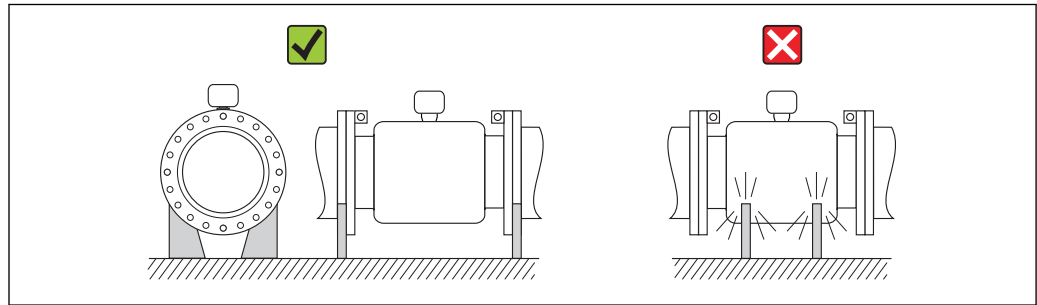

A0016276

Orientation

The direction of the arrow on the sensor nameplate helps you to install the sensor according to the flow direction (direction of medium flow through the piping).

An optimum orientation position helps avoid gas and air accumulations and deposits in the measuring tube.

The measuring device also offers the empty pipe detection function to detect partially filled measuring pipes in the event of outgassing fluids or variable process pressures.

Vertical

This is the optimum orientation for self-emptying piping systems and for use in conjunction with empty pipe detection.

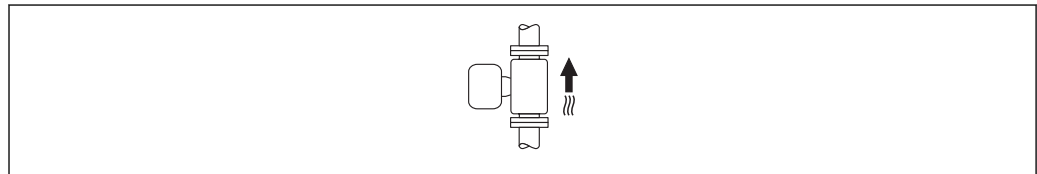

A0015591

Horizontal

The measuring electrode plane must be horizontal. This prevents brief insulation of the two measuring electrodes by entrained air bubbles.

i With horizontal orientation, empty pipe detection only works if the transmitter housing is pointing upwards as otherwise there is no guarantee that the empty pipe detection function will actually respond to a partially filled or empty measuring tube.

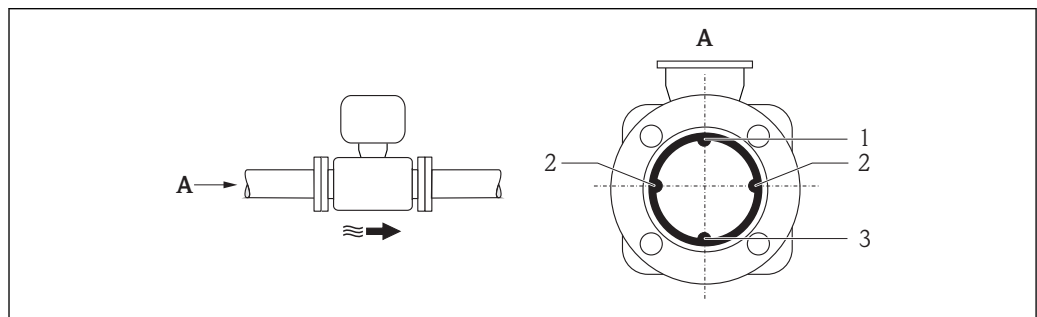

A0016260

16 Horizontal orientation

- 1 EPD electrode for empty pipe detection
- 2 Measuring electrodes for signal detection
- 3 Reference electrode for potential equalization

Inlet and outlet runs

If possible, install the sensor upstream from fittings such as valves, T-pieces or elbows.

Observe the following inlet and outlet runs to comply with accuracy specifications:

- Inlet run $\geq 5 \times DN$
- Outlet run $\geq 2 \times DN$

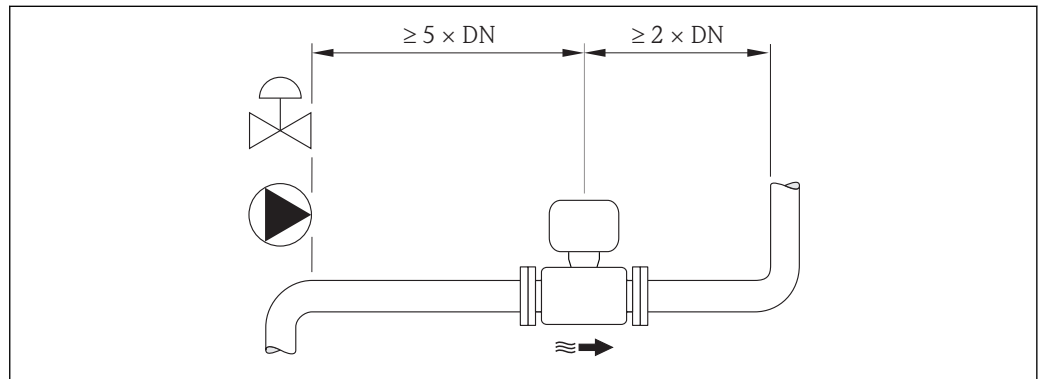

A0016275

Adapters

Suitable adapters to DIN EN 545 (double-flange reducers) can be used to install the sensor in larger diameter pipes. The resultant increase in the rate of flow improves measuring accuracy with very slow-moving fluids.

The nomogram shown here can be used to calculate the pressure loss caused by reducers and expanders:

- Calculate the ratio of the diameters d/D .
- From the nomogram read off the pressure loss as a function of flow velocity (downstream from the reduction) and the d/D ratio.

 The nomogram only applies to liquids with a viscosity similar to that of water.

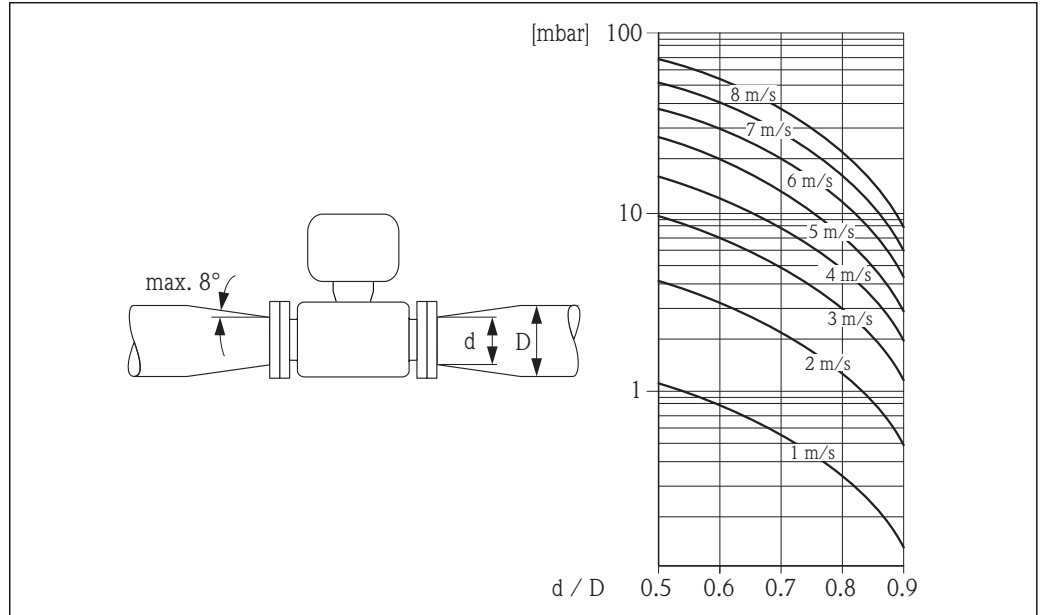

A0016359

Length of connecting cable

To ensure correct measuring results when using the remote version, observe the maximum permitted cable length L_{max} . This length is determined by the conductivity of the fluid.

If measuring liquids in general: $5 \mu S/cm$

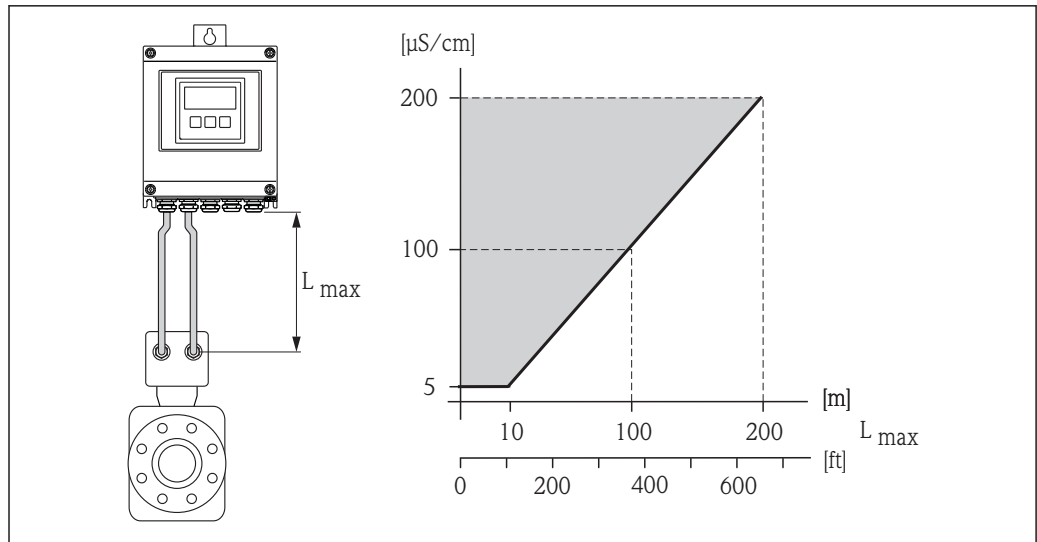

A0016539

17 Permitted length of connecting cable for remote version

Area shaded gray = permitted range

L_{max} = length of connecting cable in [m] ([ft])

[$\mu S/cm$] = fluid conductivity

Installing the wall-mount housing

Wall mounting

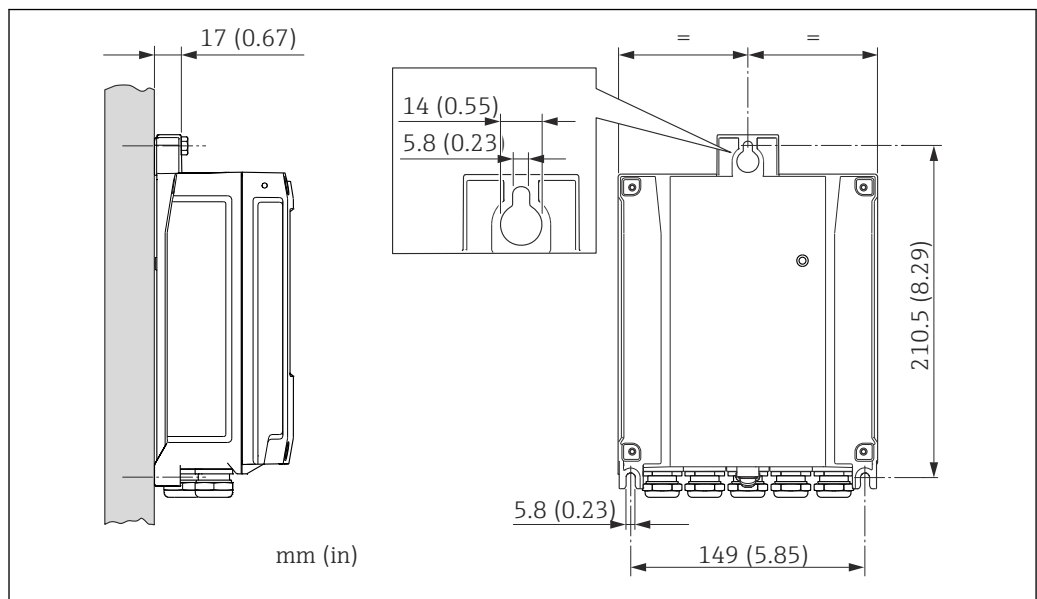

A0020523

Pipe mounting

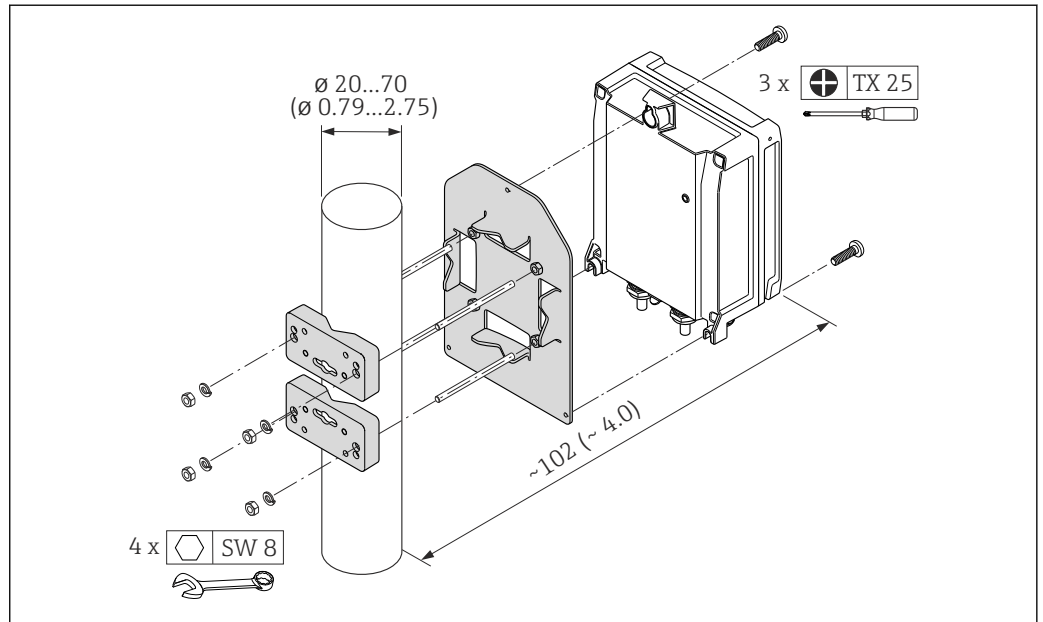

i A separate mounting kit can be ordered from Endress+Hauser for pipe mounting (→ 65).

Special mounting instructions

Display protection

To ensure that the optional display protection can be easily opened, maintain the following minimum head clearance: 350 mm (13.8 in)

Environment

Ambient temperature range	Transmitter	-40 to +60 °C (-40 to +140 °F)
	Local display	-20 to +60 °C (-4 to +140 °F), the readability of the display may be impaired at temperatures outside the temperature range.
	Sensor	<ul style="list-style-type: none"> ■ Flange material carbon steel: -10 to +60 °C (+14 to +140 °F) ■ Flange material stainless steel: -40 to +60 °C (-40 to +140 °F) Mount the transmitter separately from the sensor if both the ambient and fluid temperatures are high.
	Liner	Do not exceed or fall below the permitted temperature range of the liner (→ 30).

If operating outdoors:

- Install the measuring device in a shady location.
- Avoid direct sunlight, particularly in warm climatic regions.
- Avoid direct exposure to weather conditions.
- Protect the display against impact.
- Protect the display from abrasion by sand in desert areas.

i A display protector can be ordered from Endress+Hauser: "Accessories" section (→ 65)

Storage temperature

The storage temperature corresponds to the operating temperature range of the measuring transmitter and the appropriate measuring sensors.

- Protect the measuring device against direct sunlight during storage in order to avoid unacceptably high surface temperatures.
- Select a storage location where moisture cannot collect in the measuring device as fungus or bacteria infestation can damage the liner.
- If protection caps or protective covers are mounted these should never be removed before installing the measuring device.

Atmosphere

If a plastic transmitter housing is permanently exposed to certain steam and air mixtures, this can damage the housing.



If you are unsure, please contact your Endress+Hauser Sales Center for clarification.

Degree of protection**Transmitter**

- As standard: IP66/67, type 4X enclosure
- When housing is open: IP20, type 1 enclosure

Sensor

- As standard: IP66/67, type 4X enclosure
- Optionally available for remote version: IP68, type 6P enclosure (for DN ≤ 300 (12") only possible in conjunction with stainless steel flanges)
Not suitable for use in corrosive atmospheres/liquids or in buried applications if special precautions are not taken.

Shock resistance

Acceleration up to 2 g following IEC 60068-2-6

Vibration resistance

Acceleration up to 2 g following IEC 60068-2-6

Mechanical load

- Protect the transmitter housing against mechanical effects, such as shock or impact; the use of the remote version is sometimes preferable.
- Never use the transmitter housing as a ladder or climbing aid.

Electromagnetic compatibility (EMC)

- As per IEC/EN 61326 and NAMUR Recommendation 21 (NE 21)
- Complies with emission limits for industry as per EN 55011 (Class A)



Details are provided in the Declaration of Conformity.

Process

Medium temperature range

- 0 to +80 °C (+32 to +176 °F) for hard rubber, DN 350 to 2400 (14 to 90")
- -20 to +50 °C (-4 to +122 °F) for polyurethane, DN 50 to 1200 (2 to 48")
- -20 to +90 °C (-4 to +194 °F) for PTFE, DN 50 to 300 (2 to 12")

Conductivity

≥ 5 μS/cm for liquids in general



Note that in the case of the remote version, the requisite minimum conductivity also depends on the cable length (→ 27).

Pressure-temperature ratings

The following material load diagrams refer to the entire device and not just the process connection.

Flange connection according to EN 1092-1 (DIN 2501)

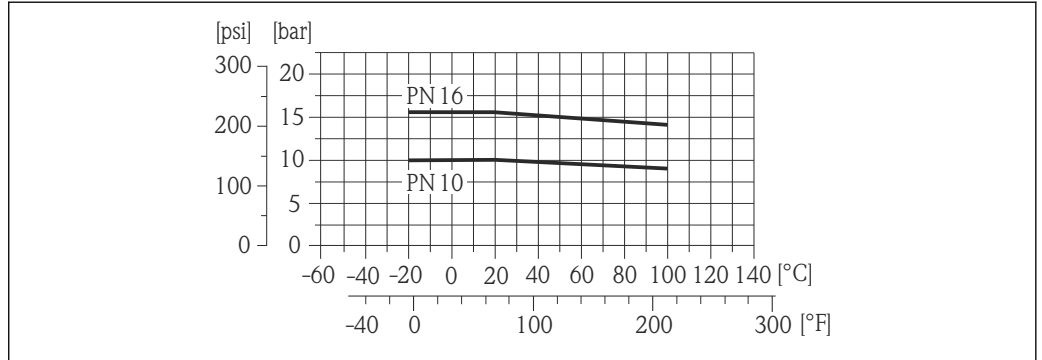

18 Lap joint flange PN 10/16, materials 1.4306 (304L) and 1.4307 (304L), DN 50 to 300 (2 to 12")

Flange connection according to EN 1092-1 (DIN 2501)

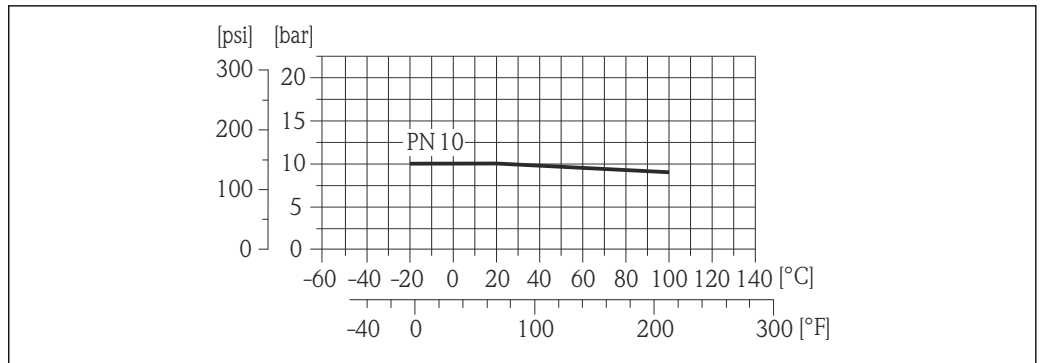

19 Lap joint flange, stamped plate PN 10, material 1.4301 (304), DN 50 to 300 (2 to 12")

Flange connection according to EN 1092-1 (DIN 2501)

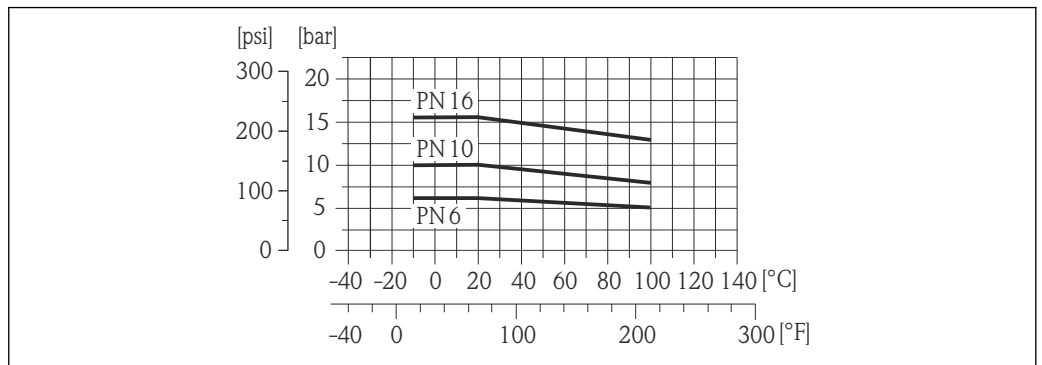

20 Fixed flange PN 6/10, materials 1.0038 (S235JRG2) and A105, DN 350 to 1000 (14 to 40") / DN 1200 to 2400 (48 to 90"); lap joint flange PN 16, material 1.0038 (S235JRG2), DN 50 to 150 (2 to 6")

Flange connection according to ASME B16.5

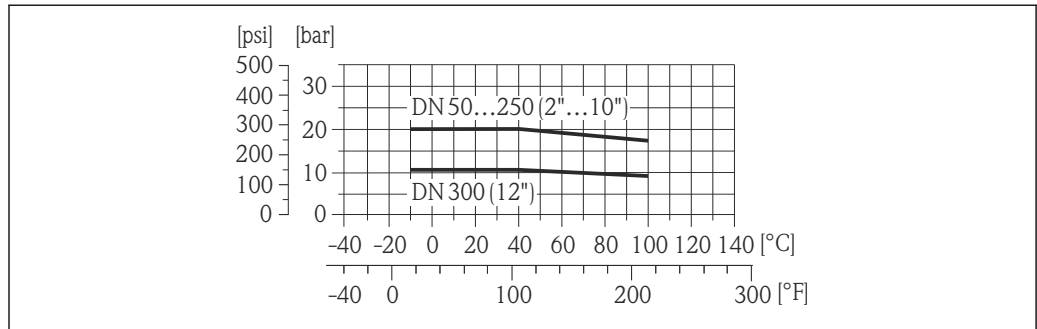

A0021403-EN

21 Lap joint flange Class 150, material A105, DN 50 to 300 (2 to 12")

Flange connection according to ASME B16.5

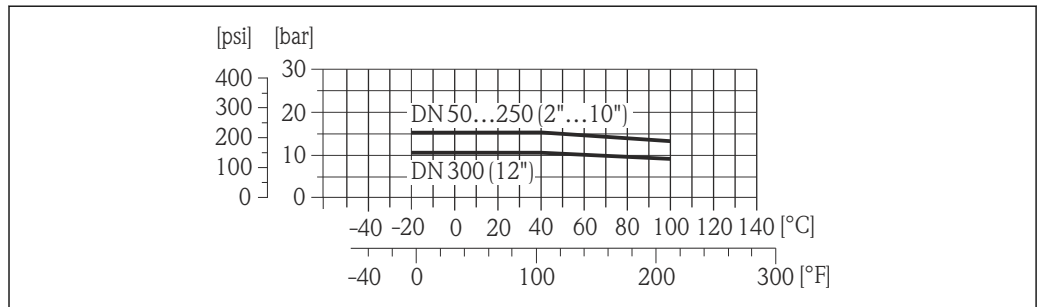

A0021404-EN

22 Lap joint flange Class 150, material 316L, DN 50 to 300 (2 to 12")

Flange connection according to ASME B16.5

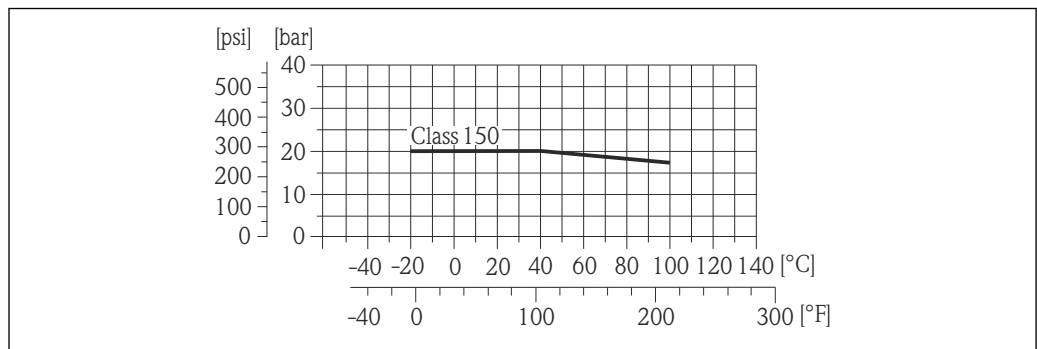

A0021405-EN

23 Fixed flange Class 150, material A105, DN 50 to 300 (2 to 12")

Flange connection according to AWWA C207

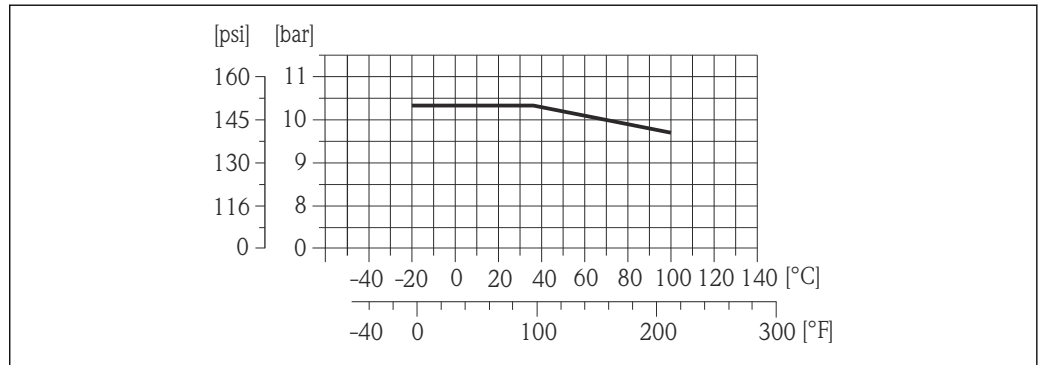

A0021406-EN

24 Fixed flange Class D, materials 1.0044 (S275JR), 1.0425 (316L) (P265GH), A105 and A181, DN 1200 to 2200 (48 to 90")

Flange connection according to AS 2129 and AS 4087

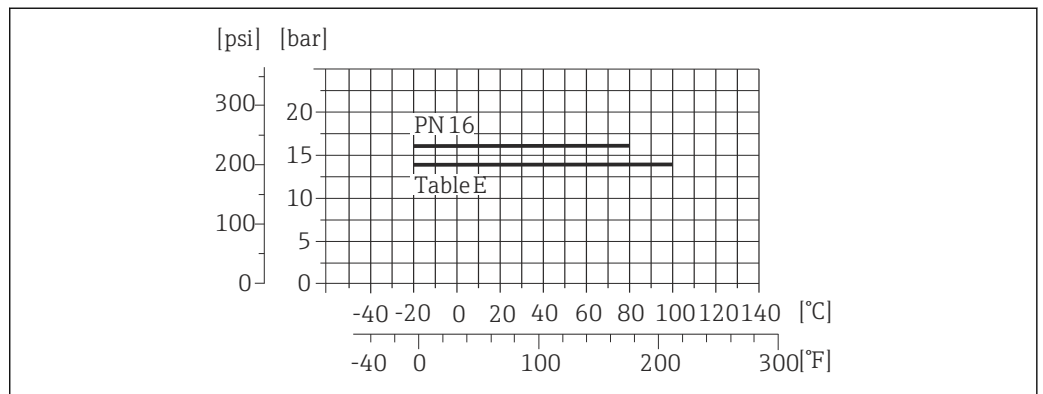

A0021419-EN

25 Fixed flange Table E, materials 1.0038 (S235JRG2), 1.0345 (P235GH), 1.0425 (316L) (P265GH), A105 and FE 410 WB, DN 350 to 1200 (14 to 48"); fixed flange PN 16, materials 1.0044 (S275JR), 1.0425 (316L) (P265GH) and A105, DN 350 to 1200 (14 to 48")

Pressure tightness

Liner: hard rubber, polyurethane

Nominal diameter		Liner	Limit values for absolute pressure in [mbar] ([psi]) for fluid temperatures:		
[mm]	[in]		+25 °C (+77 °F)	+50 °C (+122 °F)	+80 °C (+176 °F)
350...2400	14...90	Hard rubber	0 (0)	0 (0)	0 (0)
50...1200	2...48	Polyurethane	0 (0)	0 (0)	-

Liner: PTFE



Nominal diameter		Limit values for absolute pressure in [mbar] ([psi]) for fluid temperatures:	
[mm]	[in]	+25 °C (+77 °F)	+90 °C (+194 °F)
50	2	0 (0)	0 (0)
65	2 ½	0 (0)	40 (0.58)
80	3	0 (0)	40 (0.58)
100	4	0 (0)	135 (2.0)
125	5	135 (2.0)	240 (3.5)
150	6	135 (2.0)	240 (3.5)

Nominal diameter		Limit values for absolute pressure in [mbar] ([psi]) for fluid temperatures:	
[mm]	[in]	+25 °C (+77 °F)	+90 °C (+194 °F)
200	8	200 (2.9)	290 (4.2)
250	10	330 (4.8)	400 (5.8)
300	12	400 (5.8)	500 (7.3)

Flow limit

The diameter of the pipe and the flow rate determine the nominal diameter of the sensor. The optimum flow velocity is between 2 to 3 m/s (6.56 to 9.84 ft/s). Also match the velocity of flow (v) to the physical properties of the fluid:

- $v < 2$ m/s (6.56 ft/s): for abrasive fluids (e.g. potter's clay, lime milk, ore slurry)
- $v > 2$ m/s (6.56 ft/s): for fluids producing buildup (e.g. wastewater sludges)



 For an overview of the measuring range full scale values, see the "Measuring range" section ([→](#)  6)



Pressure loss

- No pressure loss occurs if the sensor is installed in a pipe with the same nominal diameter.
- Pressure losses for configurations incorporating adapters according to DIN EN 545 ([→](#)  27)

System pressure

- Never install the sensor on the pump suction side in order to avoid the risk of low pressure, and thus damage to the liner.
- Furthermore, install pulse dampers if reciprocating, diaphragm or peristaltic pumps are used.

 For information on the liner's resistance to partial vacuum ([→](#)  33)

 For information on the measuring system's resistance to vibration and shock ([→](#)  30), ([→](#)  30)

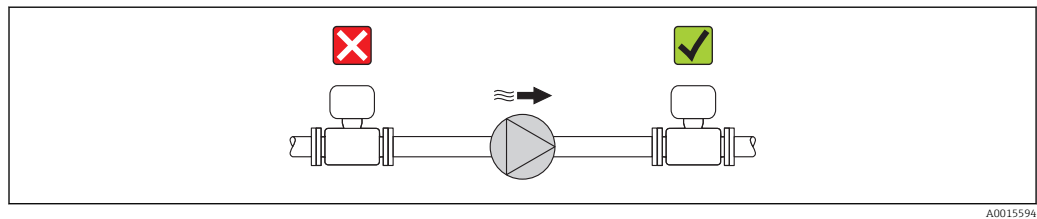

A0015594

Vibrations

In the event of very strong vibrations, the pipe and sensor must be supported and fixed.

It is also advisable to mount the sensor and transmitter separately.

 For information on the permitted resistance to vibration and shock ([→](#)  30), ([→](#)  30)

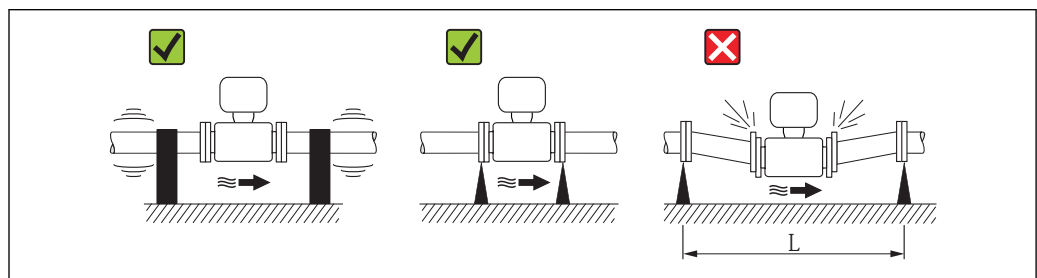

A0016266

 26 Measures to prevent vibration of the device

$L > 10$ m (33 ft)

Mechanical construction

Design, dimensions

Compact version

Order code for "Housing", option M "Compact, polycarbonate" or option A "Compact, coated aluminum" with DN 50 to 300 (2 to 12")

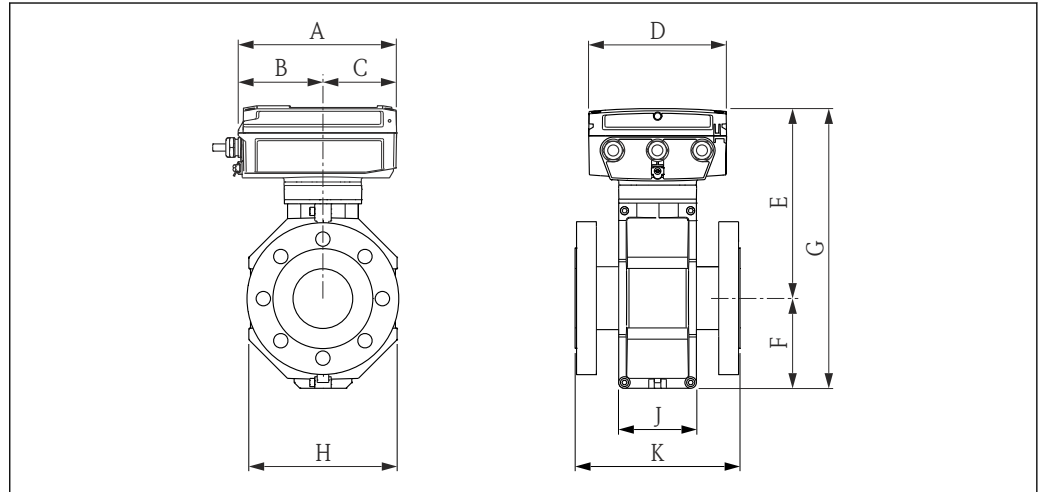

A0020352

Dimensions in SI units

DN	A	B	C	D	E	F	G	H	J	K ¹⁾
[mm]	[mm]	[mm]	[mm]	[mm]	[mm]	[mm]	[mm]	[mm]	[mm]	[mm]
50	193	103	90	167	222	84	306	120	94	200
65	193	103	90	167	247	109	356	180	94	200
80	193	103	90	167	247	109	356	180	94	200
100	193	103	90	167	247	109	356	180	94	250
125	193	103	90	167	287	150	437	260	140	250
150	193	103	90	167	287	150	437	260	140	300
200	193	103	90	167	312	180	492	324	156	350
250	193	103	90	167	337	205	542	400	166	450
300	193	103	90	167	362	230	592	460	166	500

1) The length is independent of the selected pressure rating. Length in accordance with DVGW/ISO.

Dimensions in US units

DN	A	B	C	D	E	F	G	H	J	K ¹⁾
[in]	[in]	[in]	[in]	[in]	[in]	[in]	[in]	[in]	[in]	[in]
2	7.60	4.06	3.54	6.57	8.74	3.31	12.1	4.72	3.70	7.87
3	7.60	4.06	3.54	6.57	9.72	4.29	14.0	7.09	3.70	7.87
4	7.60	4.06	3.54	6.57	9.72	4.29	14.0	7.09	3.70	9.84
6	7.60	4.06	3.54	6.57	11.3	5.91	17.2	10.2	5.51	11.8
8	7.60	4.06	3.54	6.57	12.3	7.09	19.4	12.8	6.14	13.8

DN	A	B	C	D	E	F	G	H	J	K ¹⁾
[in]	[in]	[in]	[in]	[in]	[in]	[in]	[in]	[in]	[in]	[in]
10	7.60	4.06	3.54	6.57	13.3	8.07	21.3	15.8	6.54	17.7
12	7.60	4.06	3.54	6.57	14.3	9.06	23.3	18.1	6.54	19.7

1) The length is independent of the selected pressure rating. Length in accordance with DVGW/ISO.

Order code for "Housing", option Q "Compact, polycarbonate, inclined" or option R "Compact, coated aluminum, inclined" with DN 50 to 300 (2 to 12")

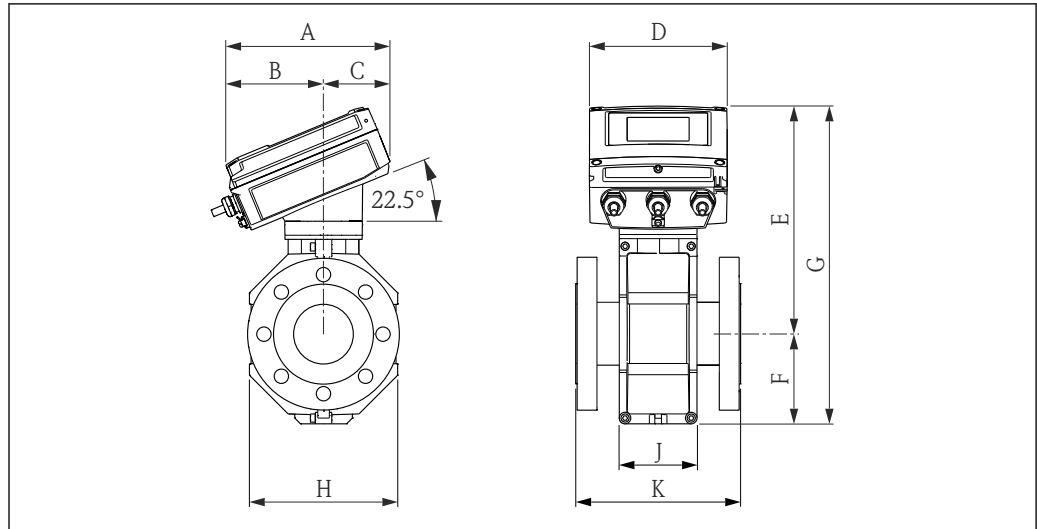

A0020353

Dimensions in SI units

DN	A	B	C	D	E	F	G	H	J	K ¹⁾
[mm]	[mm]	[mm]	[mm]	[mm]	[mm]	[mm]	[mm]	[mm]	[mm]	[mm]
50	199	119	80	167	267	84	351	120	94	200
65	199	119	80	167	292	109	401	180	94	200
80	199	119	80	167	292	109	401	180	94	200
100	199	119	80	167	292	109	401	180	94	250
125	199	119	80	167	332	150	482	260	140	250
150	199	119	80	167	332	150	482	260	140	300
200	199	119	80	167	357	180	537	324	156	350
250	199	119	80	167	382	205	587	400	166	450
300	199	119	80	167	407	230	637	460	166	500

1) The length is independent of the selected pressure rating. Length in accordance with DVGW/ISO.

Dimensions in US units

DN	A	B	C	D	E	F	G	H	J	K ¹⁾
[in]	[in]	[in]	[in]	[in]	[in]	[in]	[in]	[in]	[in]	[in]
2	7.83	4.69	3.15	6.57	10.5	3.31	13.8	4.72	3.70	7.87
3	7.83	4.69	3.15	6.57	11.5	4.29	15.8	7.09	3.70	7.87
4	7.83	4.69	3.15	6.57	11.5	4.29	15.8	7.09	3.70	9.84
6	7.83	4.69	3.15	6.57	13.1	5.91	19.0	10.2	5.51	11.8

DN	A	B	C	D	E	F	G	H	J	K ¹⁾
[in]	[in]	[in]	[in]	[in]	[in]	[in]	[in]	[in]	[in]	[in]
8	7.83	4.69	3.15	6.57	14.1	7.09	21.1	12.8	6.14	13.8
10	7.83	4.69	3.15	6.57	15.0	8.07	23.1	15.8	6.54	17.7
12	7.83	4.69	3.15	6.57	16.0	9.06	25.1	18.1	6.54	19.7

1) The length is independent of the selected pressure rating. Length in accordance with DVGW/ISO.

Order code for "Housing", option M "Compact, polycarbonate" or option A "Compact, coated aluminum" with DN 350 to 2400 (14 to 90")

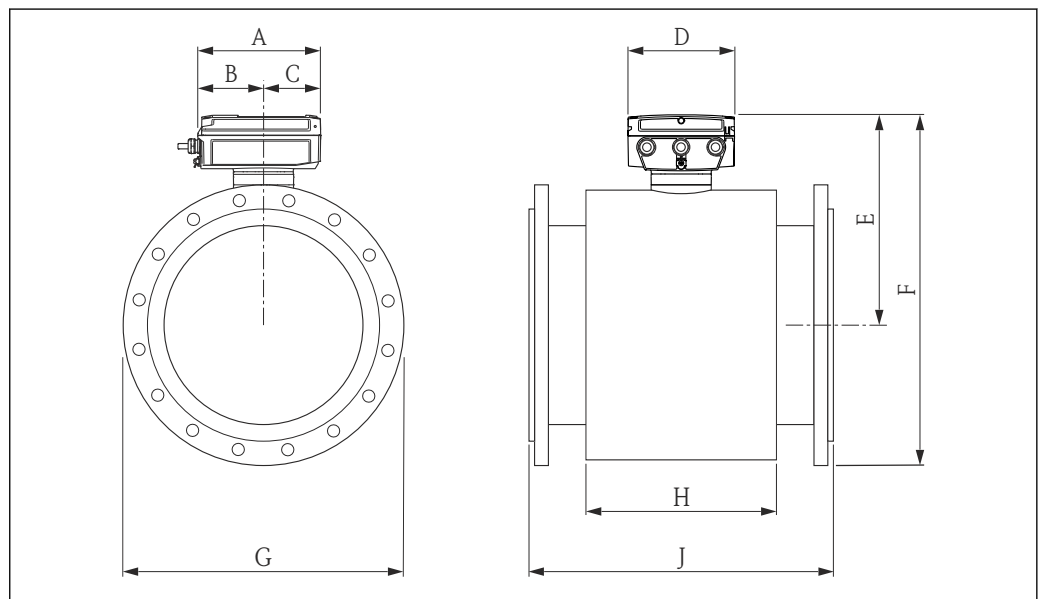

A0017153

Dimensions in SI units

DN	A	B	C	D	E	H	J
[mm]	[mm]	[mm]	[mm]	[mm]	[mm]	[mm]	[mm]
350	193	103	90	167	386	290	550
375	193	103	90	167	412	290	600
400	193	103	90	167	412	290	600
450	193	103	90	167	440	290	600
500	193	103	90	167	465	290	600
600	193	103	90	167	506	290	600
700	193	103	90	167	571	424	700
750	193	103	90	167	608	454	750
800	193	103	90	167	627	500	800
900	193	103	90	167	677	580	900
1000	193	103	90	167	727	660	1000
1050	193	103	90	167	763	755	1050
1200	193	103	90	167	841	828	1200
1350	193	103	90	167	953	1008	1350
1400	193	103	90	167	953	1008	1400

DN [mm]	A [mm]	B [mm]	C [mm]	D [mm]	E [mm]	H [mm]	J [mm]
1500	193	103	90	167	1053	1147	1500
1600	193	103	90	167	1053	1147	1600
1650	193	103	90	167	1104	1284	1650
1800	193	103	90	167	1161	1379	1800
2000	193	103	90	167	1272	1569	2000
2150	193	103	90	167	1372	1711	2150
2200	193	103	90	167	1372	1711	2200
2300	193	103	90	167	1477	1859	2300
2400	193	103	90	167	1477	1859	2400

DN [mm]	Dimension F					Dimension G				
	EN (DIN)			ASME	AS	EN (DIN)			ASME	AS
	PN 6 [mm]	PN 10 [mm]	PN 16 [mm]	AWWA [mm]	[mm]	PN 6 [mm]	PN 10 [mm]	PN 16 [mm]	AWWA [mm]	AS [mm]
350	631	638	702	653	648	490	505	520	533	525
375	-	-	-	-	687	-	-	-	-	550
400	682	694	760	710	702	540	565	580	597	580
450	737	747	823	757	760	595	615	640	635	640
500	787	800	926	814	817	645	670	715	699	705
600	883	896	1026	912	918	755	780	840	813	825
700	1001	1018	1145	1034	1026	860	895	910	927	910
750	-	-	-	1100	1106	-	-	-	984	995
800	1115	1135	1240	1157	1157	975	1015	1025	1060	1060
900	1215	1235	1240	1261	1265	1075	1115	1125	1168	1175
1000	1315	1342	1355	1372	1355	1175	1230	1225	1289	1255
1050	-	-	-	1436	-	-	-	-	1346	-
1200	1544	1569	1584	1597	1586	1405	1455	1255	1511	1490
1350	-	-	-	1795	-	-	-	-	1683	-
1400	1768	1791	1796	-	-	1630	1675	1685	-	-
1500	-	-	-	1980	-	-	-	-	1854	-
1600	1968	2011	2019	-	-	1830	1915	1930	-	-
1650	-	-	-	2120	-	-	-	-	2032	-
1800	2183	2218	2226	2259	-	2045	2115	2130	2197	-
2000	2404	2434	2444	2453	-	2265	2325	2345	2362	-
2150	-	-	-	2639	-	-	-	-	2534	-
2200	2609	2647	-	-	-	2475	2550	-	-	-
2300	-	-	-	2829	-	-	-	-	2705	-
2400	2819	2857	-	-	-	2685	2760	-	-	-

Dimensions in US units

DN [in]	A [in]	B [in]	C [in]	D [in]	E [in]	H [in]	J [in]
14	7.60	4.06	3.54	6.57	15.2	11.4	21.6
15	7.60	4.06	3.54	6.57	16.2	11.4	23.6
16	7.60	4.06	3.54	6.57	16.2	11.4	23.6
18	7.60	4.06	3.54	6.57	17.3	11.4	23.6
20	7.60	4.06	3.54	6.57	18.3	11.4	23.6
24	7.60	4.06	3.54	6.57	19.9	11.4	23.6
28	7.60	4.06	3.54	6.57	22.5	16.7	27.6
30	7.60	4.06	3.54	6.57	23.9	17.9	29.5
32	7.60	4.06	3.54	6.57	24.7	19.7	31.5
36	7.60	4.06	3.54	6.57	26.6	22.8	35.4
40	7.60	4.06	3.54	6.57	28.6	26.0	39.4
42	7.60	4.06	3.54	6.57	30.0	29.7	41.3
48	7.60	4.06	3.54	6.57	33.1	32.6	47.2
54	7.60	4.06	3.54	6.57	37.5	39.7	53.1
60	7.60	4.06	3.54	6.57	41.4	45.2	59.0
66	7.60	4.06	3.54	6.57	43.4	50.6	64.9
72	7.60	4.06	3.54	6.57	45.7	54.3	70.8
78	7.60	4.06	3.54	6.57	50.1	61.8	78.7
84	7.60	4.06	3.54	6.57	54.0	67.4	84.6
90	7.60	4.06	3.54	6.57	58.1	73.2	90.5

DN [in]	Dimension F					Dimension G				
	EN (DIN)			ASME	AS	EN (DIN)			ASME	AS
	PN 6 [in]	PN 10 [in]	PN 16 [in]	AWWA [in]	[in]	PN 6 [in]	PN 10 [in]	PN 16 [in]	AWWA [in]	[in]
14	24.8	25.1	27.6	25.7	25.5	19.3	19.9	20.5	21.0	20.7
15	-	-	-	-	27	-	-	-	-	21.7
16	26.8	27.3	30.0	27.0	27.6	21.3	22.2	22.8	23.5	22.8
18	29.0	29.4	32.4	29.8	29.9	23.4	24.2	25.2	25.0	25.2
20	31.0	31.5	36.5	32.0	32.1	25.4	26.4	28.1	27.5	27.8
24	34.7	35.3	40.4	35.9	36.1	29.7	30.7	33.1	32.0	32.5
28	39.4	40.1	45.1	40.7	40.4	33.9	35.2	35.8	36.5	35.8
30	-	-	-	43.3	43.5	-	-	-	38.7	39.2
32	43.9	44.7	48.8	45.5	45.5	38.4	40.0	40.4	41.7	41.7
36	47.8	48.6	48.8	49.6	49.8	42.3	43.9	44.3	46.0	46.3
40	51.7	52.8	53.4	54.0	53.3	46.3	48.4	48.2	50.7	49.4
42	-	-	-	56.5	-	-	-	-	53.0	-
48	60.8	61.7	62.4	62.9	62.4	55.3	57.3	49.4	59.5	58.7
54	-	-	-	70.6	-	-	-	-	66.3	-
60	-	-	-	77.9	-	-	-	-	73.0	-

DN [in]	Dimension F					Dimension G				
	EN (DIN)			ASME	AS	EN (DIN)			ASME	AS
	PN 6 [in]	PN 10 [in]	PN 16 [in]	AWWA [in]		PN 6 [in]	PN 10 [in]	PN 16 [in]	AWWA [in]	
66	-	-	-	83.4	-	-	-	-	80.0	-
72	85.9	87.3	87.6	88.9	-	80.5	83.3	83.9	86.5	-
78	94.6	95.8	96.2	96.6	-	89.2	91.5	92.3	93.0	-
84	-	-	-	104.0	-	-	-	-	99.8	-
90	-	-	-	111.0	-	-	-	-	-	-

Order code for "Housing", option Q "Compact, polycarbonate, inclined" or option R "Compact, coated aluminum, inclined" with DN 350 to 2400 (14 to 90")

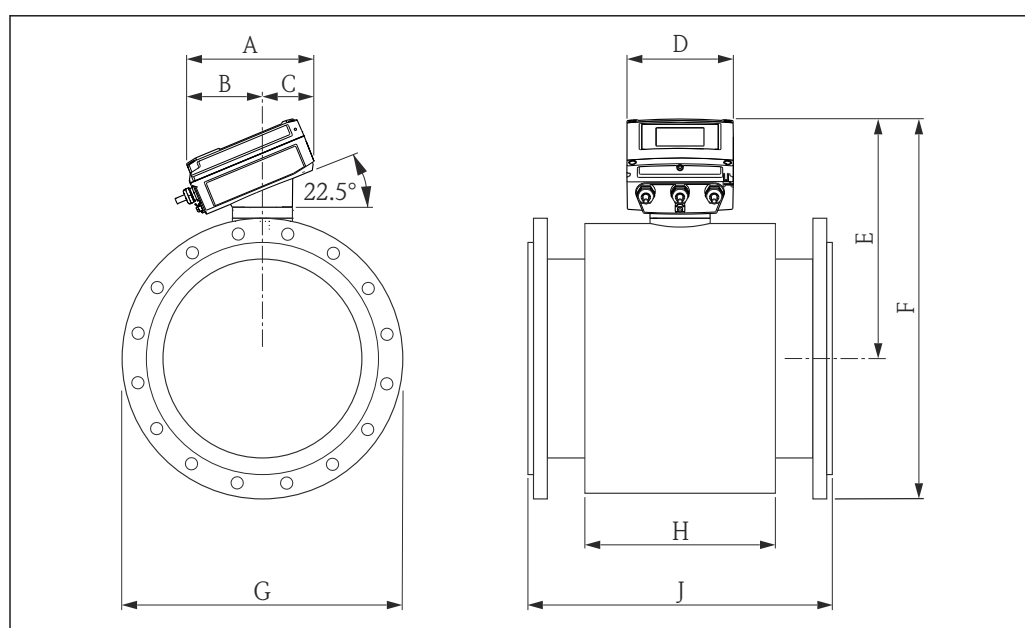

A0020393

Dimensions in SI units

DN [mm]	A [mm]	B [mm]	C [mm]	D [mm]	E [mm]	H [mm]	J [mm]
350	199	119	80	167	431	290	550
375	199	119	80	167	457	290	600
400	199	119	80	167	457	290	600
450	199	119	80	167	485	290	600
500	199	119	80	167	510	290	600
600	199	119	80	167	551	290	600
700	199	119	80	167	616	424	700
750	199	119	80	167	653	454	750
800	199	119	80	167	672	500	800
900	199	119	80	167	722	580	900
1000	199	119	80	167	772	660	1000
1050	199	119	80	167	808	755	1050

DN [mm]	A [mm]	B [mm]	C [mm]	D [mm]	E [mm]	H [mm]	J [mm]
1200	199	119	80	167	886	828	1200
1350	199	119	80	167	998	1008	1350
1400	199	119	80	167	953	1008	1400
1500	199	119	80	167	1098	1147	1500
1600	199	119	80	167	1098	1147	1600
1650	199	119	80	167	1149	1284	1650
1800	199	119	80	167	1206	1379	1800
2000	199	119	80	167	1317	1569	2000
2150	199	119	80	167	1417	1711	2150
2200	199	119	80	167	1417	1711	2200
2300	199	119	80	167	1522	1859	2300
2400	199	119	80	167	1522	1859	2400

DN [mm]	Dimension F					Dimension G				
	EN (DIN)			ASME	AS	EN (DIN)			ASME	AS
	PN 6 [mm]	PN 10 [mm]	PN 16 [mm]	AWWA [mm]	[mm]	PN 6 [mm]	PN 10 [mm]	PN 16 [mm]	AWWA [mm]	[mm]
350	676	683	618	698	693	490	505	520	533	525
375	-	-	-	-	732	-	-	-	-	550
400	727	739	672	755	747	540	565	580	597	580
450	782	792	732	802	805	595	615	640	635	640
500	832	845	795	859	862	645	670	715	699	705
600	928	941	898	957	963	755	780	840	813	825
700	1046	1063	1008	1079	1071	860	895	910	927	910
750	-	-	-	1145	1151	-	-	-	984	995
800	1160	1180	1112	1202	1202	975	1015	1025	1060	1060
900	1260	1280	1212	1306	1310	1075	1115	1125	1168	1175
1000	1360	1387	1327	1417	1400	1175	1230	1225	1289	1255
1050	-	-	-	1481	-	-	-	-	1346	-
1200	1589	1614	1556	1642	1631	1405	1455	1255	1511	1490
1350	-	-	-	1840	-	-	-	-	1683	-
1400	1813	1836	1768	-	-	1630	1675	1685	-	-
1500	-	-	-	2025	-	-	-	-	1854	-
1600	2013	2056	1991	-	-	1830	1915	1930	-	-
1650	-	-	-	2165	-	-	-	-	2032	-
1800	2228	2263	2198	2304	-	2045	2115	2130	2197	-
2000	2449	2479	2416	2498	-	2265	2325	2345	2362	-
2150	-	-	-	2684	-	-	-	-	2534	-
2200	2654	2692	-	-	-	2475	2550	-	-	-
2300	-	-	-	2874	-	-	-	-	2705	-
2400	2864	2902	-	-	-	2685	2760	-	-	-

Dimensions in US units

DN [in]	A [in]	B [in]	C [in]	D [in]	E [in]	H [in]	J [in]
14	7.83	4.69	3.15	6.57	17.0	11.4	21.6
15	7.83	4.69	3.15	6.57	18.0	11.4	23.6
16	7.83	4.69	3.15	6.57	18.0	11.4	23.6
18	7.83	4.69	3.15	6.57	19.1	11.4	23.6
20	7.83	4.69	3.15	6.57	20.1	11.4	23.6
24	7.83	4.69	3.15	6.57	21.7	11.4	23.6
28	7.83	4.69	3.15	6.57	24.3	16.7	27.6
30	7.83	4.69	3.15	6.57	25.7	17.9	29.5
32	7.83	4.69	3.15	6.57	26.5	19.7	31.5
36	7.83	4.69	3.15	6.57	28.4	22.8	35.4
40	7.83	4.69	3.15	6.57	30.4	26.0	39.4
42	7.83	4.69	3.15	6.57	31.8	29.7	41.3
48	7.83	4.69	3.15	6.57	34.9	32.6	47.2
54	7.83	4.69	3.15	6.57	39.3	39.7	53.1
60	7.83	4.69	3.15	6.57	43.2	45.2	59.0
66	7.83	4.69	3.15	6.57	45.2	50.6	64.9
72	7.83	4.69	3.15	6.57	47.5	54.3	70.8
78	7.83	4.69	3.15	6.57	51.9	61.8	78.7
84	7.83	4.69	3.15	6.57	55.8	67.4	84.6
90	7.83	4.69	3.15	6.57	59.9	73.2	90.5

DN [in]	Dimension F					Dimension G				
	EN (DIN)			ASME	AS	EN (DIN)			ASME	AS
	PN 6 [in]	PN 10 [in]	PN 16 [in]	AWWA [in]		PN 6 [in]	PN 10 [in]	PN 16 [in]	AWWA [in]	AS [in]
14	26.6	26.9	24.3	27.5	27.3	19.3	19.9	20.5	21.0	20.7
15	-	-	-	-	28.8	-	-	-	-	21.7
16	28.6	29.1	26.5	28.8	29.4	21.3	22.2	22.8	23.5	22.8
18	30.8	31.2	28.8	31.6	31.7	23.4	24.2	25.2	25.0	25.2
20	32.8	33.3	31.3	33.8	33.9	25.4	26.4	28.1	27.5	27.8
24	36.5	37.1	35.4	37.7	37.9	29.7	30.7	33.1	32.0	32.5
28	41.2	41.9	39.7	42.5	42.2	33.9	35.2	35.8	36.5	35.8
30	-	-	-	45.1	45.3	-	-	-	38.7	39.2
32	45.7	46.5	43.8	47.3	47.3	38.4	40.0	40.4	41.7	41.7
36	49.6	50.4	47.7	51.4	49.8	42.3	43.9	44.3	46.0	46.3
40	53.5	54.6	52.2	55.8	55.1	46.3	48.4	48.2	50.7	49.4
42	-	-	-	58.3	-	-	-	-	53.0	-
48	62.6	63.5	61.3	64.7	64.2	55.3	57.3	49.4	59.5	58.7
54	-	-	-	72.4	-	-	-	-	66.3	-
60	-	-	-	79.7	-	-	-	-	73.0	-

DN [in]	Dimension F					Dimension G				
	EN (DIN)			ASME	AS	EN (DIN)			ASME	AS
	PN 6 [in]	PN 10 [in]	PN 16 [in]	AWWA [in]		PN 6 [in]	PN 10 [in]	PN 16 [in]	AWWA [in]	
66	-	-	-	85.2	-	-	-	-	80.0	-
72	87.7	89.1	86.5	90.7	-	80.5	83.3	83.9	86.5	-
78	96.4	97.6	95.1	98.4	-	89.2	91.5	92.3	93.0	-
84	-	-	-	105.8	-	-	-	-	99.8	-
90	-	-	-	112.8	-	-	-	-	-	-

Transmitter remote version

Order code for "Housing", option N "Remote, polycarbonate" or option P "Remote, coated aluminum"

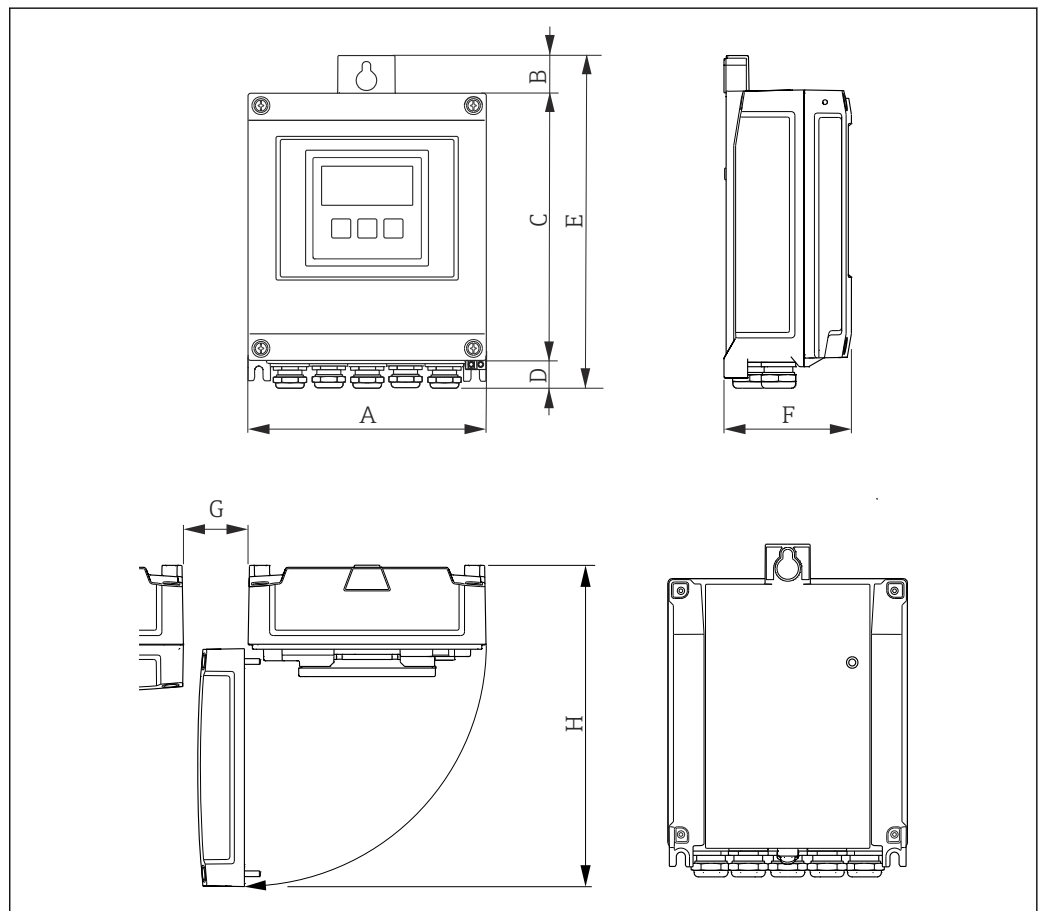

A0020522

Dimensions in SI units

A [mm]	B [mm]	C [mm]	D [mm]	E [mm]	F [mm]	G [mm]	H [mm]
167	24	187	21	232	80	50	240

Dimensions in US units

A [in]	B [in]	C [in]	D [in]	E [in]	F [in]	G [in]	H [in]
6.57	0.94	7.36	0.83	9.13	3.15	1.97	9.5

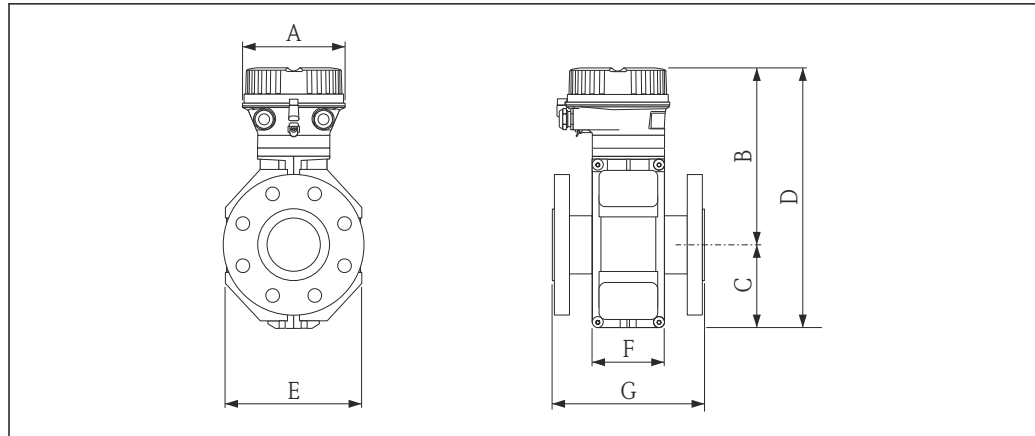
Sensor remote version*DN 50 to 300 (2 to 12")*

A0017282

Dimensions in SI units

DN [mm]	A [mm]	B [mm]	C [mm]	D [mm]	E [mm]	F [mm]	G ¹⁾ [mm]
50	136	207	84	291	120	94	200
65	136	232	109	341	180	94	200
80	136	232	109	341	180	94	200
100	136	232	109	341	180	94	250
125	136	272	150	422	260	140	250
150	136	272	150	422	260	140	300
200	136	297	180	477	324	156	350
250	136	322	205	527	400	156	450
300	136	347	230	577	460	166	500

1) The length is independent of the selected pressure rating. Length in accordance with DVGW/ISO.

Dimensions in US units

DN [in]	A [in]	B [in]	C [in]	D [in]	E [in]	F [in]	G ¹⁾ [in]
2	5.35	8.15	3.31	11.5	4.72	3.70	7.87
3	5.35	9.13	4.29	13.4	7.09	3.70	7.87
4	5.35	9.13	4.29	13.4	7.09	3.70	9.84
6	5.35	10.7	5.91	16.6	10.2	5.51	11.8
8	5.35	11.7	7.09	18.8	12.8	6.14	13.8

DN [in]	A [in]	B [in]	C [in]	D [in]	E [in]	F [in]	G ¹⁾ [in]
10	5.35	12.7	8.07	20.8	15.8	6.14	17.7
12	5.35	13.7	9.06	22.8	18.1	6.54	19.7

1) The length is independent of the selected pressure rating. Length in accordance with DVGW/ISO.

DN 350 to 2400 (14 to 90")

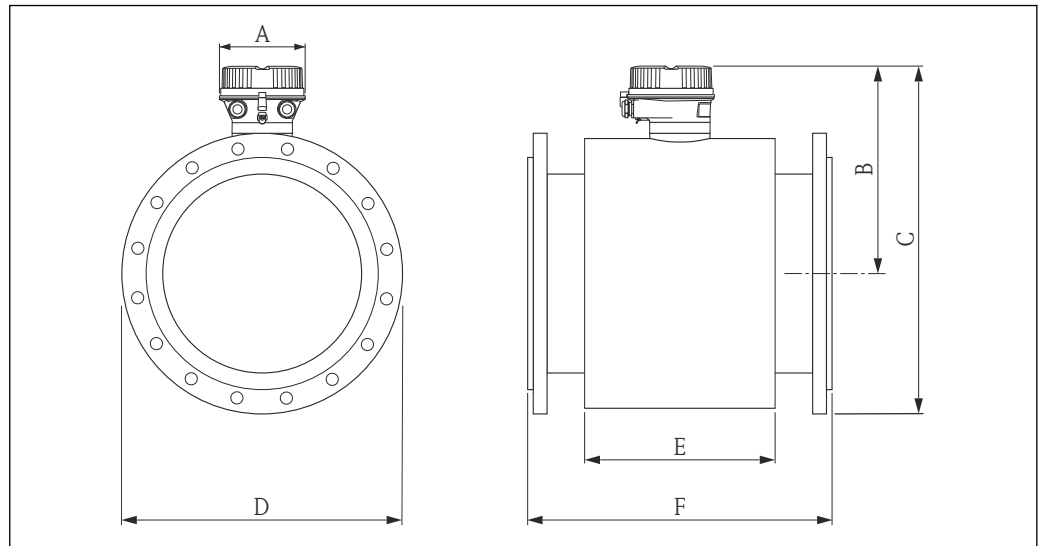

A0017284

Dimensions in SI units

DN [mm]	A [mm]	B [mm]	E [mm]	F [mm]
350	136	358	290	550
375	136	384	290	600
400	136	384	290	600
450	136	412	290	600
500	136	437	290	600
600	136	478	290	600
700	136	543	424	700
750	136	579	454	750
800	136	599	500	800
900	136	649	580	900
1000	136	699	660	1000
1050	136	735	755	1050
1200	136	813	828	1200
1350	136	925	1008	1350
1400	136	925	1008	1400
1500	136	1025	1147	1500
1600	136	1025	1147	1600
1650	136	1076	1284	1650

DN [mm]	A [mm]	B [mm]	E [mm]	F [mm]
1800	136	1133	1379	1800
2000	136	1244	1569	2000
2150	136	1344	1711	2150
2200	136	1344	1711	2200
2300	136	1449	1859	2300
2400	136	1449	1859	2400

DN [mm]	Dimension C					Dimension D				
	EN (DIN)			ASME	AS	EN (DIN)			ASME	AS
	PN 6 [mm]	PN 10 [mm]	PN 16 [mm]	AWWA [mm]	[mm]	PN 6 [mm]	PN 10 [mm]	PN 16 [mm]	AWWA [mm]	[mm]
350	603	610	616	625	620	490	505	520	533	525
375	-	-	-	-	659	-	-	-	-	550
400	654	666	672	682	674	540	565	580	597	580
450	709	719	729	729	732	595	615	640	635	640
500	759	772	791	786	789	645	670	715	699	705
600	855	868	903	884	890	755	780	840	813	825
700	973	990	1009	1006	998	860	895	910	927	910
750	-	-	-	1072	1078	-	-	-	984	995
800	1087	1107	1123	1129	1129	975	1015	1025	1060	1060
900	1187	1207	1223	1233	1237	1075	1115	1125	1168	1175
1000	1287	1314	1338	1344	1327	1175	1230	1225	1289	1255
1050	-	-	-	1408	-	-	-	-	1346	-
1200	1516	1541	1567	1569	1558	1405	1455	1255	1511	1490
1350	-	-	-	1767	-	-	-	-	1683	-
1400	1740	1763	1779	-	-	1630	1675	1685	-	-
1500	-	-	-	1952	-	-	-	-	1854	-
1600	1940	1983	2002	-	-	1830	1915	1930	-	-
1650	-	-	-	2092	-	-	-	-	2032	-
1800	2155	2190	2209	2231	-	2045	2115	2130	2197	-
2000	2376	2406	2427	2425	-	2265	2325	2345	2362	-
2150	-	-	-	2611	-	-	-	-	2534	-
2200	2581	2619	-	-	-	2475	2550	-	-	-
2300	-	-	-	2801	-	-	-	-	2705	-
2400	2791	2829	-	-	-	2685	2760	-	-	-

Dimensions in US units

DN [in]	A [in]	B [in]	E [in]	F [in]
14	5.35	14.1	11.4	21.6
15	5.35	15.1	11.4	23.6

DN [in]	A [in]	B [in]	E [in]	F [in]
16	5.35	15.1	11.4	23.6
18	5.35	16.2	11.4	23.6
20	5.35	17.2	11.4	23.6
24	5.35	18.8	11.4	23.6
28	5.35	21.6	16.7	27.6
30	5.35	23.0	17.9	29.5
32	5.35	23.6	19.7	31.5
36	5.35	25.6	22.8	35.4
40	5.35	27.5	26.0	39.4
42	5.35	28.9	29.7	41.3
48	5.35	32.0	32.6	47.2
54	5.35	36.4	39.6	53.1
60	5.35	40.4	45.2	59.0
66	5.35	42.4	50.6	64.9
72	5.35	44.6	54.2	70.8
78	5.35	49.0	61.8	78.7
84	5.35	52.9	67.4	84.6
90	5.35	57.1	73.2	90.5

DN [in]	Dimension C					Dimension D				
	EN (DIN)			ASME	AS	EN (DIN)			ASME	AS
	PN 6 [in]	PN 10 [in]	PN 16 [in]	AWWA [in]	[in]	PN 6 [in]	PN 10 [in]	PN 16 [in]	AWWA [in]	[in]
14	23.7	24.0	24.3	24.6	24.4	19.3	19.9	20.5	21.0	20.7
15	-	-	-	-	25.9	-	-	-	-	21.7
16	25.8	26.2	26.5	26.9	26.5	21.3	22.2	22.8	23.5	22.8
18	27.9	28.3	28.7	28.7	28.8	23.4	24.2	25.2	25.0	25.2
20	29.9	30.4	31.1	30.9	31.1	25.4	26.4	28.1	27.5	27.8
24	33.7	34.2	35.6	34.8	35.0	29.7	30.7	33.1	32.0	32.5
28	38.5	39.2	39.7	39.8	39.5	33.9	35.2	35.8	36.5	35.8
30	-	-	-	42.4	42.4	-	-	-	38.7	39.2
32	43.0	43.8	44.2	44.6	44.6	38.4	40.0	40.4	41.7	41.7
36	46.9	47.7	48.2	48.7	48.9	42.3	43.9	44.3	46.0	46.3
40	50.8	51.9	52.7	53.1	52.4	46.3	48.4	48.2	50.7	49.4
42	-	-	-	55.6	-	-	-	-	53.0	-
48	59.9	60.8	61.7	62.0	61.5	55.3	57.3	49.4	59.5	58.7
54	-	-	-	69.6	-	-	-	-	66.3	-
60	-	-	-	76.9	-	-	-	-	73.0	-
66	-	-	-	82.4	-	-	-	-	80.0	-
72	84.9	86.3	87.0	87.9	-	80.5	83.3	83.9	86.5	-
78	93.6	94.7	95.6	95.5	-	89.2	91.5	92.3	93.0	-

DN [in]	Dimension C					Dimension D				
	EN (DIN)			ASME	AS	EN (DIN)			ASME	AS
	PN 6 [in]	PN 10 [in]	PN 16 [in]	AWWA [in]	[in]	PN 6 [in]	PN 10 [in]	PN 16 [in]	AWWA [in]	[in]
84	-	-	-	102.8	-	-	-	-	99.8	-
90	-	-	-	110.3	-	-	-	-	106.5	-

Order code for "Sensor option", option CK "IP68, Type 6P, water-proof" with DN 350 to 2000 (14 to 78")

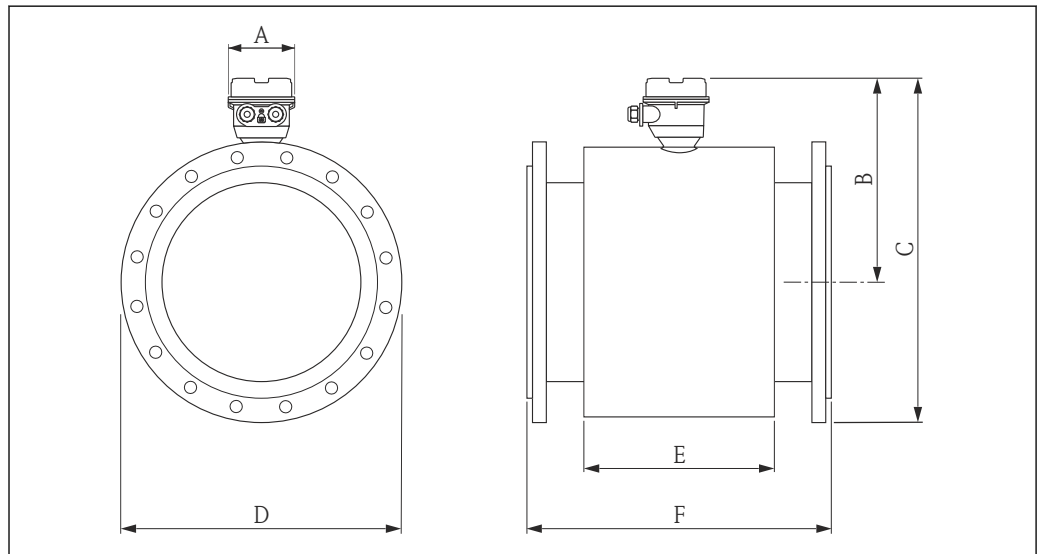

A0020436

Dimensions in SI units

DN [mm]	A [mm]	B [mm]	C [mm]	D [mm]	E [mm]	F [mm]
350	112	364	617	520	290	550
375	112	390	-	-	290	600
400	112	390	673	580	290	600
450	112	418	730	640	290	600
500	112	443	792	715	290	600
600	112	484	904	840	290	600
700	112	549	1010	910	424	700
750	112	585	-	-	454	750
800	112	605	1224	1025	500	800
900	112	655	1224	1125	580	900
1000	112	705	1339	1225	660	1000
1050	112	741	-	-	755	1050
1200	112	819	1568	1255	828	1200
1350	112	931	-	-	1008	1350
1400	112	931	1780	1685	1008	1400
1500	112	1031	-	-	1147	1500
1600	112	1031	2003	1930	1147	1600

DN [mm]	A [mm]	B [mm]	C [mm]	D [mm]	E [mm]	F [mm]
1650	112	1082	-	-	1284	1650
1800	112	1139	2210	2130	1379	1800
2000	112	1250	2428	2345	1569	2000

Dimensions in US units

DN [in]	A [in]	B [in]	C [in]	D [in]	E [in]	F [in]
14	4.41	14.3	24.3	20.5	11.4	21.6
15	4.41	15.4	-	-	11.4	23.6
16	4.41	15.4	26.5	22.8	11.4	23.6
18	4.41	16.5	28.7	25.2	11.4	23.6
20	4.41	17.4	31.2	28.1	11.4	23.6
24	4.41	19.1	35.6	33.1	11.4	23.6
28	4.41	21.6	39.8	35.8	16.7	27.6
30	4.41	23.0	-	-	17.9	29.5
32	4.41	23.8	44.2	40.4	19.7	31.5
36	4.41	25.8	48.2	44.3	22.8	35.4
40	4.41	27.8	52.7	48.2	26.0	39.4
42	4.41	29.2	-	-	29.7	41.3
48	4.41	32.2	61.7	49.4	32.6	47.2
54	4.41	36.7	-	-	39.6	53.1
60	4.41	40.6	-	-	45.2	59.0
66	4.41	42.6	-	-	50.6	64.9
72	4.41	44.8	87.0	83.9	54.2	70.8
78	4.41	49.2	95.6	92.3	61.8	78.7

Accessories

Ground disks for flange connections

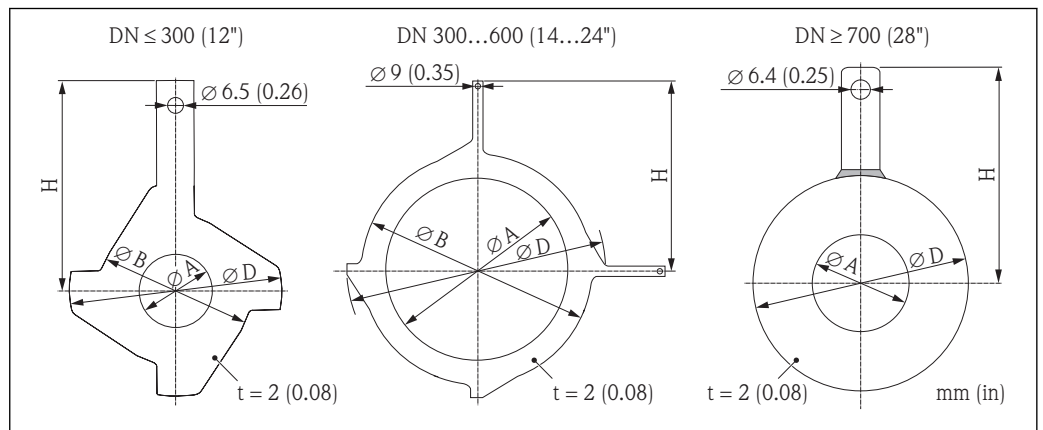

A0015442

Dimensions in SI and US units

DN		Pressure rating	A		B		D		H	
[mm]	[in]		[mm]	[in]	[mm]	[in]	[mm]	[in]	[mm]	[in]
50	2	¹⁾	52	2.05	101	3.98	115.5	4.55	108	4.25
65	2 ½	¹⁾	68	2.68	121	4.76	131.5	5.18	118	4.65
80	3	¹⁾	80	3.15	131	5.16	154.5	6.08	135	5.31
100	4	¹⁾	104	4.09	156	6.14	186.5	7.34	153	6.02
125	5	¹⁾	130	5.12	187	7.36	206.5	8.13	160	6.30
150	6	¹⁾	158	6.22	217	8.54	256	10.1	184	7.24
200	8	¹⁾	206	8.11	267	10.5	288	11.3	205	8.07
250	10	¹⁾	260	10.2	328	12.9	359	14.1	240	9.45
300	12	¹⁾	312	12.3	375	14.8	413	16.3	273	10.8
350	14	DIN, PN 6	343	13.5	433	16.5	479	18.9	365	14.4
350	14	DIN, PN 10	343	13.5	400	15.8	479	18.9	365	14.4
350	14	ASME, Class 150	343	13.5	400	15.8	479	18.9	365	14.4
400	16	DIN, PN 6	393	15.5	470	18.5	542	21.3	395	15.6
400	16	DIN, PN 10	393	15.5	469	18.5	542	21.3	395	15.6
400	16	ASME, Class 150	393	15.5	469	18.5	542	21.3	395	15.6
450	18	DIN, PN 6	439	17.3	525	20.7	583	23.0	417	16.4
450	18	DIN, PN 10	439	17.3	535	21.1	583	23.0	417	16.4
450	18	ASME, Class 150	439	17.3	535	21.1	583	23.0	417	16.4
500	20	DIN, PN 6	493	19.4	575	23.3	650	25.6	460	18.1
500	20	DIN, PN 10	493	19.4	588	23.2	650	25.6	460	18.1
500	20	ASME, Class 150	493	19.4	588	23.2	650	25.6	460	18.1
600	24	DIN, PN 6	593	23.4	676	27.3	766	30.2	522	20.6
600	24	DIN, PN 10	593	23.4	688	27.1	766	30.2	522	20.6
600	24	ASME, Class 150	593	23.4	688	27.1	766	30.2	522	20.6
700	28	DIN, PN 6	697	27.4	-	-	786	30.9	460	18.1
700	28	DIN, PN 10	693	27.3	-	-	813	32.0	480	18.9
700	28	AS, PN 16	687	27.1	-	-	807	31.8	490	19.3
700	28	AWWA, Class D	693	27.3	-	-	832	32.8	494	19.5
750	30	AWWA, Class D	743	29.3	-	-	833	32.8	523	20.6
800	32	DIN, PN 6	799	31.5	-	-	893	35.2	520	20.5
800	32	DIN, PN 10	795	31.3	-	-	920	36.2	540	21.3
800	32	AS, PN 16	789	31.1	-	-	914	36.0	550	21.7
800	32	AWWA, Class D	795	31.3	-	-	940	37.0	561	22.1
900	36	DIN, PN 6	897	35.3	-	-	993	39.1	570	22.4
900	36	DIN, PN 10	893	35.2	-	-	1020	40.2	590	23.2
900	36	AS, PN 16	886	34.9	-	-	1014	39.9	595	23.4
900	36	AWWA, Class D	893	35.2	-	-	1048	41.3	615	24.2
1000	40	DIN, PN 6	999	39.3	-	-	1093	43.0	620	24.4

DN		Pressure rating	A		B		D		H	
[mm]	[in]		[mm]	[in]	[mm]	[in]	[mm]	[in]	[mm]	[in]
1000	40	DIN, PN 10	995	39.2	-	-	1127	44.4	650	25.6
1000	40	AS, PN 16	988	38.9	-	-	1131	44.5	660	26.0
1000	40	AWWA, Class D	995	39.2	-	-	1163	45.8	675	26.6
1050	42	AWWA, Class D	1044	41.1	-	-	1220	48.0	704	27.7
1200	48	DIN, PN 6	1203	47.4	-	-	1310	51.6	733	28.9

1) Ground disks can be used for all the flange standards/pressure ratings which can be supplied in the standard version.

Weight

Compact version

- Weight data:
- Including the transmitter
 - Polycarbonate plastic: 1.3 kg (2.9 lbs)
 - Aluminum: 2.0 kg (4.4 lbs)
 - Excluding packaging material

Weight in SI units

Lap joint flange; fixed flange DN ≥ 350 (14")

Nominal diameter		EN (DIN)						ASME, AWWA		AS			
[mm]	[in]	Pressure rating	[kg] ¹⁾	Pressure rating	[kg] ¹⁾	Pressure rating	[kg] ¹⁾	Pressure rating	[kg] ¹⁾	Pressure rating	[kg] ¹⁾	Pressure rating	[kg] ¹⁾
50	2	PN 6	-	PN 10	-	PN 16	9	Class 150	9	PN 16	-	Table E	-
65	2 ½	PN 6	-	PN 10	-	PN 16	10	Class 150	-	PN 16	-	Table E	-
80	3	PN 6	-	PN 10	-	PN 16	12	Class 150	12	PN 16	-	Table E	-
100	4	PN 6	-	PN 10	-	PN 16	14	Class 150	14	PN 16	-	Table E	-
125	5	PN 6	-	PN 10	-	PN 16	20	Class 150	-	PN 16	-	Table E	-
150	6	PN 6	-	PN 10	-	PN 16	24	Class 150	24	PN 16	-	Table E	-
200	8	PN 6	-	PN 10	43	PN 16	-	Class 150	43	PN 16	-	Table E	-
250	10	PN 6	-	PN 10	63	PN 16	-	Class 150	63	PN 16	-	Table E	-
300	12	PN 6	-	PN 10	68	PN 16	-	Class 150	68	PN 16	-	Table E	-
350	14	PN 6	77	PN 10	88	PN 16	103	Class 150	137	PN 16	99	Table E	99
375	15	PN 6	-	PN 10	-	PN 16	-	Class 150	-	PN 16	105	Table E	-
400	16	PN 6	89	PN 10	104	PN 16	121	Class 150	168	PN 16	120	Table E	120
450	18	PN 6	99	PN 10	112	PN 16	138	Class 150	191	PN 16	133	Table E	143
500	20	PN 6	114	PN 10	132	PN 16	178	Class 150	228	PN 16	182	Table E	182
600	24	PN 6	155	PN 10	162	PN 16	223	Class 150	302	PN 16	260	Table E	260
700	28	PN 6	190	PN 10	240	PN 16	287	Class D	266	PN 16	367	Table E	346
750	30	PN 6	-	PN 10	-	PN 16	-	Class D	318	PN 16	445	Table E	433
800	32	PN 6	240	PN 10	315	PN 16	349	Class D	383	PN 16	503	Table E	493
900	36	PN 6	308	PN 10	393	PN 16	440	Class D	470	PN 16	702	Table E	690
1000	40	PN 6	359	PN 10	468	PN 16	562	Class D	587	PN 16	759	Table E	761
1050	42	PN 6	-	PN 10	-	PN 16	-	Class D	670	PN 16	-	Table E	-
1200	48	PN 6	529	PN 10	717	PN 16	839	Class D	901	PN 16	1219	Table E	1237
-	54	PN 6	-	PN 10	-	PN 16	-	Class D	1273	PN 16	-	Table E	-

Nominal diameter		EN (DIN)						ASME, AWWA		AS			
[mm]	[in]	Pressure rating	[kg] ¹⁾	Pressure rating	[kg] ¹⁾	Pressure rating	[kg] ¹⁾	Pressure rating	[kg] ¹⁾	Pressure rating	[kg] ¹⁾	Pressure rating	[kg] ¹⁾
1400	-	PN 6	784	PN 10	1114	PN 16	1200	Class D	-	PN 16	-	Table E	-
-	60	PN 6	-	PN 10	-	PN 16	-	Class D	1594	PN 16	-	Table E	-
1600	-	PN 6	1058	PN 10	1624	PN 16	1840	Class D	-	PN 16	-	Table E	-
1650	66	PN 6	-	PN 10	-	PN 16	-	Class D	2131	PN 16	-	Table E	-
1800	72	PN 6	1484	PN 10	2107	PN 16	2353	Class D	2568	PN 16	-	Table E	-
2000	78	PN 6	1877	PN 10	2630	PN 16	2925	Class D	3113	PN 16	-	Table E	-
-	84	PN 6	-	PN 10	-	PN 16	-	Class D	3755	PN 16	-	Table E	-
2200	-	PN 6	2512	PN 10	3422	PN 16	-	Class D	-	PN 16	-	Table E	-
-	90	PN 6	-	PN 10	-	PN 16	-	Class D	4797	PN 16	-	Table E	-
2400	-	PN 6	2996	PN 10	4094	PN 16	-	Class D	-	PN 16	-	Table E	-

1) Values with polycarbonate plastic transmitter; values for aluminum transmitter: + 0.7 kg

Lap joint flange, stamped plate

Nominal diameter		EN (DIN)	
[mm]	[in]	Pressure rating	[kg] ¹⁾
50	2	PN 10	5
65	2 ½	PN 10	6
80	3	PN 10	7
100	4	PN 10	9
125	5	PN 10	13
150	6	PN 10	17
200	8	PN 10	35
250	10	PN 10	54
300	12	PN 10	55

1) Values with polycarbonate plastic transmitter; values for aluminum transmitter: + 0.7 kg

Weight in US units

Lap joint flange; fixed flange DN ≥ 350 (14")

Nominal diameter		ASME, AWWA	
[mm]	[in]	Pressure rating	[lbs] ¹⁾
50	2	Class 150	20
65	2 ½	Class 150	-
80	3	Class 150	26
100	4	Class 150	31
125	5	Class 150	-
150	6	Class 150	53
200	8	Class 150	95
250	10	Class 150	139
300	12	Class 150	150

Nominal diameter		ASME, AWWA	
[mm]	[in]	Pressure rating	[lbs] ¹⁾
350	14	Class 150	302
375	15	Class 150	-
400	16	Class 150	370
450	18	Class 150	421
500	20	Class 150	503
600	24	Class 150	666
700	28	Class D	586
750	30	Class D	701
800	32	Class D	844
900	36	Class D	1036
1000	40	Class D	1294
-	42	Class D	1477
1200	48	Class D	1987
-	54	Class D	2807
-	60	Class D	3515
1650	66	Class D	4699
1800	72	Class D	5662
2000	78	Class D	6864
-	84	Class D	8280
-	90	Class D	10577

1) Values with polycarbonate plastic transmitter; values for aluminum transmitter: + 1.45 lbs

Transmitter remote version

Wall-mount housing

Depends on the material of the wall-mount housing:

- Polycarbonate plastic: 1.3 kg (2.9 lb)
- Aluminum: 2.0 kg (4.4 lb)

Sensor remote version

Weight data:

- Including sensor connection housing
- Excluding the connecting cable
- Excluding packaging material

Weight in SI units

Lap joint flange; fixed flange DN ≥ 350 (14")

Nominal diameter		EN (DIN)				ASME, AWWA		AS					
[mm]	[in]	Pressure rating	[kg]	Pressure rating	[kg]	Pressure rating	[kg]	Pressure rating	[kg]	Pressure rating	[kg]	Pressure rating	[kg]
50	2	PN 6	-	PN 10	-	PN 16	6	Class 150	6	PN 16	-	Table E	-
65	2 ½	PN 6	-	PN 10	-	PN 16	7	Class 150	-	PN 16	-	Table E	-
80	3	PN 6	-	PN 10	-	PN 16	9	Class 150	9	PN 16	-	Table E	-
100	4	PN 6	-	PN 10	-	PN 16	11	Class 150	11	PN 16	-	Table E	-

Nominal diameter		EN (DIN)						ASME, AWWA		AS			
[mm]	[in]	Pressure rating	[kg]	Pressure rating	[kg]	Pressure rating	[kg]	Pressure rating	[kg]	Pressure rating	[kg]	Pressure rating	[kg]
125	5	PN 6	-	PN 10	-	PN 16	16	Class 150	-	PN 16	-	Table E	-
150	6	PN 6	-	PN 10	-	PN 16	20	Class 150	20	PN 16	-	Table E	-
200	8	PN 6	-	PN 10	40	PN 16	-	Class 150	40	PN 16	-	Table E	-
250	10	PN 6	-	PN 10	60	PN 16	-	Class 150	60	PN 16	-	Table E	-
300	12	PN 6	-	PN 10	65	PN 16	-	Class 150	65	PN 16	-	Table E	-
350	14	PN 6	73	PN 10	84	PN 16	101	Class 150	133	PN 16	95	Table E	95
375	15	PN 6	-	PN 10	-	PN 16	-	Class 150	-	PN 16	101	Table E	-
400	16	PN 6	85	PN 10	100	PN 16	119	Class 150	164	PN 16	116	Table E	116
450	18	PN 6	95	PN 10	108	PN 16	136	Class 150	187	PN 16	129	Table E	139
500	20	PN 6	110	PN 10	128	PN 16	176	Class 150	224	PN 16	178	Table E	178
600	24	PN 6	158	PN 10	158	PN 16	221	Class 150	298	PN 16	256	Table E	256
700	28	PN 6	187	PN 10	237	PN 16	285	Class D	263	PN 16	364	Table E	343
750	30	PN 6	-	PN 10	-	PN 16	-	Class D	315	PN 16	442	Table E	430
800	32	PN 6	237	PN 10	312	PN 16	347	Class D	380	PN 16	500	Table E	490
900	36	PN 6	305	PN 10	390	PN 16	438	Class D	467	PN 16	699	Table E	687
1000	40	PN 6	356	PN 10	465	PN 16	560	Class D	584	PN 16	756	Table E	758
1050	42	PN 6	-	PN 10	-	PN 16	-	Class D	667	PN 16	-	Table E	-
1200	48	PN 6	526	PN 10	714	PN 16	837	Class D	898	PN 16	1216	Table E	1234
-	54	PN 6	-	PN 10	-	PN 16	-	Class D	1270	PN 16	-	Table E	-
1400	-	PN 6	781	PN 10	1111	PN 16	1197	Class D	-	PN 16	-	Table E	-
-	60	PN 6	-	PN 10	-	PN 16	-	Class D	1591	PN 16	-	Table E	-
1600	-	PN 6	1055	PN 10	1621	PN 16	1838	Class D	-	PN 16	-	Table E	-
1650	66	PN 6	-	PN 10	-	PN 16	-	Class D	2128	PN 16	-	Table E	-
1800	72	PN 6	1415	PN 10	2104	PN 16	2350	Class D	2565	PN 16	-	Table E	-
2000	78	PN 6	1874	PN 10	2627	PN 16	2922	Class D	3110	PN 16	-	Table E	-
-	84	PN 6	-	PN 10	-	PN 16	-	Class D	3752	PN 16	-	Table E	-
2200	-	PN 6	2509	PN 10	3419	PN 16	-	Class D	-	PN 16	-	Table E	-
-	90	PN 6	-	PN 10	-	PN 16	-	Class D	4794	PN 16	-	Table E	-
2400	-	PN 6	2993	PN 10	4091	PN 16	-	Class D	-	PN 16	-	Table E	-

Lap joint flange, stamped plate

Nominal diameter		EN (DIN)	
[mm]	[in]	Pressure rating	[kg]
50	2	PN 10	3
65	2 ½	PN 10	4
80	3	PN 10	5
100	4	PN 10	7
125	5	PN 10	11
150	6	PN 10	15
200	8	PN 10	33

Nominal diameter		EN (DIN)	
[mm]	[in]	Pressure rating	[kg]
250	10	PN 10	52
300	12	PN 10	53

Weight in US units

Lap joint flange; fixed flange DN ≥ 350 (14")

Nominal diameter		ASME, AWWA	
[mm]	[in]	Pressure rating	[lbs]
50	2	Class 150	13
65	2 ½	Class 150	-
80	3	Class 150	20
100	4	Class 150	24
125	5	Class 150	-
150	6	Class 150	44
200	8	Class 150	88
250	10	Class 150	132
300	12	Class 150	143
350	14	Class 150	293
375	15	Class 150	-
400	16	Class 150	361
450	18	Class 150	412
500	20	Class 150	494
600	24	Class 150	657
700	28	Class D	580
750	30	Class D	695
800	32	Class D	838
900	36	Class D	1030
1000	40	Class D	1288
-	42	Class D	1471
1200	48	Class D	1980
-	54	Class D	2800
-	60	Class D	3508
1650	66	Class D	4692
1800	72	Class D	5656
2000	78	Class D	6858
-	84	Class D	8273
-	90	Class D	10571

Measuring tube specification

Nominal diameter		Pressure rating			Measuring tube internal diameter					
		EN (DIN)	ASME AWWA	AS 2129 AS 4087	Hard rubber		Polyurethane		PTFE	
[mm]	[in]				[mm]	[in]	[mm]	[in]	[mm]	[in]
50	2	PN 10/16	Class 150	-	-	-	50.3	2.0	51.7	2.0
65 ¹⁾	2 ½	PN 10/16	Class 150	-	-	-	66.1	2.6	67.7	2.7
80	3	PN 10/16	Class 150	-	-	-	78.9	3.1	79.9	3.1
100	4	PN 10/16	Class 150	-	-	-	104.3	4.1	103.8	4.1
125	5	PN 10/16	Class 150	-	-	-	129.7	5.1	129.1	5.1
150	6	PN 10/16	Class 150	-	-	-	158.3	6.2	156.3	6.2
200	8	PN 10/16	Class 150	-	-	-	206.7	8.1	202.1	8.0
250	10	PN 10/16	Class 150	-	-	-	260.6	10.3	256.2	10.1
300	12	PN 10/16	-	-	-	-	311.5	12.3	305.5	12.0
300	12	-	Class 150	-	-	-	309.9	12.2	303.9	12.0
350	14	PN 6	-	-	341	13.4	344	13.5	-	-
350	14	PN 10	-	-	341	13.4	344	13.5	-	-
350	14	-	-	Table E, PN 16	339	13.3	342	13.4	-	-
350	14	-	Class 150	-	339	13.3	342	13.4	-	-
375	15	PN 10	-	-	391	15.4	-	-	-	-
375	15	-	-	PN 16	389	15.3	392	15.4	-	-
400	16	PN 6	-	-	391	15.4	394	13.5	-	-
400	16	PN 10	-	-	442	17.4	394	13.5	-	-
400	16	-	-	Table E, PN 16	389	15.3	392	13.4	-	-
400	16	-	Class 150	-	389	15.3	392	13.4	-	-
450	18	PN 6	-	-	442	17.4	445	17.5	-	-
450	18	PN 10	-	-	493	19.4	445	17.5	-	-
450	18	-	-	Table E, PN 16	440	17.3	443	17.4	-	-
450	18	-	Class 150	-	438	17.2	441	17.3	-	-
500	20	PN 6	-	-	493	19.4	496	19.5	-	-
500	20	PN 10	-	-	595	23.4	496	19.5	-	-
500	20	-	-	Table E, PN 16	489	19.2	492	19.3	-	-
500	20	-	Class 150	-	489	19.2	492	19.3	-	-
600	24	PN 6	-	-	595	23.4	598	23.5	-	-
600	24	PN 10	-	-	590	23.2	598	23.5	-	-
600	24	-	-	Table E, PN 16	591	23.2	594	23.4	-	-
600	24	-	Class 150	-	589	23.1	592	23.3	-	-
700	28	PN 6	-	-	696	27.4	699	27.5	-	-
700	28	PN 10	-	-	694	27.3	697	27.4	-	-
700	28	-	-	Table E, PN 16	690	27.2	693	27.3	-	-
700	28	-	Class D	-	694	27.3	697	27.4	-	-
750	30	PN 6	-	-	-	-	699	27.5	-	-
750	30	PN 10	-	-	-	-	697	27.4	-	-
750	30	-	-	Table E, PN 16	741	29.2	744	29.3	-	-

Nominal diameter		Pressure rating			Measuring tube internal diameter					
		EN (DIN)	ASME AWWA	AS 2129 AS 4087	Hard rubber		Polyurethane		PTFE	
[mm]	[in]				[mm]	[in]	[mm]	[in]	[mm]	[in]
750	30	-	Class D	-	743	29.3	746	29.4	-	-
800	32	PN 6	-	-	798	31.4	801	31.5	-	-
800	32	PN 10	-	-	796	31.3	799	31.5	-	-
800	32	-	-	Table E, PN 16	792	31.2	795	31.3	-	-
800	32	-	Class D	-	794	31.3	797	31.4	-	-
900	36	PN 6	-	-	897	35.3	900	35.4	-	-
900	36	PN 10	-	-	895	35.2	898	35.4	-	-
900	36	-	-	Table E, PN 16	889	35.0	892	35.1	-	-
900	36	-	Class D	-	895	35.2	898	35.4	-	-
1000	40	PN 6	-	-	999	39.3	1002	39.4	-	-
1000	40	PN 10	-	-	997	39.3	1000	39.4	-	-
1000	40	-	-	Table E, PN 16	991	39.0	994	39.1	-	-
1000	40	-	Class D	-	995	39.1	998	39.3	-	-
1050	42	PN 6	-	-	-	-	-	-	-	-
1050	42	PN 10	-	-	-	-	-	-	-	-
1050	42	-	-	Table E, PN 16	-	-	-	-	-	-
1050	42	-	Class D	-	1046	41.2	1049	41.3	-	-
1200	48	PN 6	-	-	1203	47.4	1206	47.5	-	-
1200	48	PN 10	-	-	1199	47.2	1202	47.3	-	-
1200	48	-	-	Table E, PN 16	1191	46.9	1194	47.0	-	-
1200	48	-	Class D	-	1195	47.0	1198	47.2	-	-
-	54	-	Class D	-	1345	53.8	-	-	-	-
1400	-	PN 6	-	-	1402	56.1	-	-	-	-
1400	-	PN 10	-	-	1394	55.78	-	-	-	-
-	60	-	Class D	-	1498	59.9	-	-	-	-
1600	-	PN 6	-	-	1600	64.0	-	-	-	-
1600	-	PN 10	-	-	1590	63.6	-	-	-	-
-	66	-	Class D	-	1646	65.8	1198	47.2	-	-
1800	72	PN 6	-	-	1800	72.0	1206	47.5	-	-
1800	72	PN 10	-	-	1790	71.6	1202	47.3	-	-
1800	72	-	Class D	-	1790	71.6	1198	47.2	-	-
2000	78	PN 6	-	-	1998	79.9	-	-	-	-
2000	78	PN 10	-	-	1990	79.6	-	-	-	-
2000	78	-	Class D	-	1986	79.4	-	-	-	-
-	84	-	Class D	-	2099	84.0	-	-	-	-
2200	-	PN 6	-	-	2194	87.8	-	-	-	-
2200	-	PN 10	-	-	2186	87.4	-	-	-	-
-	90	-	Class D	-	2246	89.8	-	-	-	-

Nominal diameter		Pressure rating			Measuring tube internal diameter					
		EN (DIN)	ASME AWWA	AS 2129 AS 4087	Hard rubber		Polyurethane		PTFE	
[mm]	[in]				[mm]	[in]	[mm]	[in]	[mm]	[in]
2 400	-	PN 6	-	-	2 394	95.8	-	-	-	-
2 400	-	PN 10	-	-	2 386	95.4	-	-	-	-

1) Designed acc. to EN 1092-1 (not to DIN 2501)

Materials

Transmitter housing

Order code for "Housing"

- Compact version, standard:
 - Option **A**: coated aluminum AlSi10Mg
 - Option **M**: polycarbonate plastic
- Compact version, inclined:
 - Option **Q**: polycarbonate plastic
 - Option **R**: coated aluminum AlSi10Mg
- Remote version (wall-mount housing):
 - Option **N**: polycarbonate plastic
 - Option **P**: coated aluminum AlSi10Mg

Window material

Transmitter housing material	Window material
Polycarbonate plastic	Plastic
Aluminum AlSi10Mg	Glass

Cable entries/cable glands

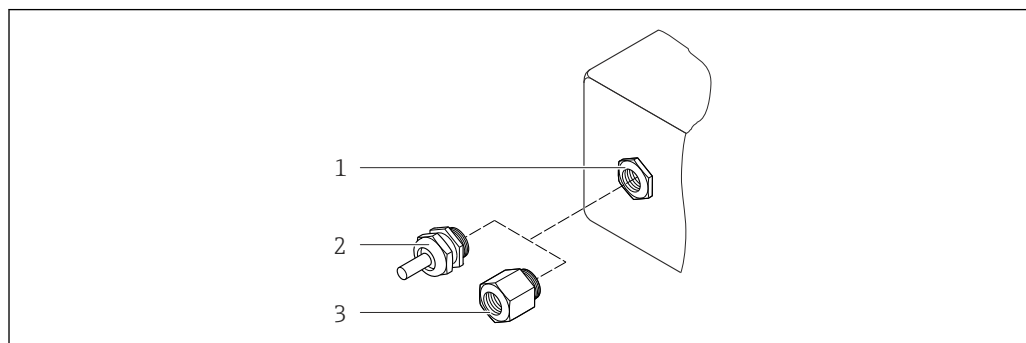

A0020640

27 Possible cable entries/cable glands

- 1 Cable entry in transmitter housing, wall-mount housing or connection housing with internal thread M20 x 1.5
- 2 Cable gland M20 x 1.5
- 3 Adapter for cable entry with internal thread G 1/2" or NPT 1/2"

Compact and remote versions and sensor connection housing

Cable entry/cable gland	Material
Cable gland M20 × 1.5	Plastic
Remote version: cable gland M20 × 1.5 <ul style="list-style-type: none"> ▪ Option CK "IP68, Type 6P, waterproof" ▪ Option of reinforced connecting cable 	<ul style="list-style-type: none"> ▪ Sensor connection housing: Nickel-plated brass ▪ Transmitter wall-mount housing: Plastic
Adapter for cable entry with internal thread G ½" or NPT ½"	Nickel-plated brass

Device plug

Electrical connection	Material
Plug M12x1	<ul style="list-style-type: none"> ▪ Socket: Stainless steel 1.4404 (316L) ▪ Contact housing: Polyamide ▪ Contacts: Gold-plated brass

Connecting cable for remote version

Electrode and coil current cable

- Standard cable: PVC cable with copper shield
- Reinforced cable: PVC cable with copper shield and additional steel wire braided jacket

Sensor housing

- DN 50 to 300 (2 to 12"): aluminum coated AlSi10Mg
- DN 350 to 2400 (14 to 90"): carbon steel with protective varnish

Sensor connection housing

Aluminum coated AlSi10Mg

Sensor cable entries

Order code for "Housing", option N "Remote, polycarbonate" or option P "Remote, coated aluminum"

The various cable entries are suitable for hazardous and non-hazardous areas.

Electrical connection	Material
Cable gland M20 × 1.5	Nickel-plated brass
Thread G ½" via adapter	Nickel-plated brass
Thread NPT ½" via adapter	Nickel-plated brass

Measuring tubes

- DN 50 to 300 (2 to 12"): stainless steel 1.4301 (304), 1.4306 (304L)
- DN 350 to 2400 (14 to 90"): stainless steel 1.4301 (304), 1.4307

Liner

- DN 50 to 300 (2 to 12"): PTFE
- DN 50 to 1200 (2 to 48"): polyurethane
- DN 350 to 2400 (14 to 90"): hard rubber

Electrodes

1.4435 (304L), Alloy C22

Process connections*EN 1092-1 (DIN 2501)*

- DN ≤ 300 (12"): 1.0038 (S235JRG2), 1.4301 (304), 1.4306 (304L), 1.4307 (304L)
- DN ≥ 350 (14"): 1.0038 (S235JRG2), A105

ASME B16.5

- DN ≤ 300 (12"): A105, 316L
- DN ≥ 350 (14"): A105

AWWA C207

DN 1200 to 2200 (48 to 90"): 1.0044 (S275JR), 1.0425 (316L) (P265GH), A105, A181

AS 2129

DN 350 to 1200 (14 to 48"): 1.0038 (S235JRG2), 1.0345 (P235GH), 1.0425 (316L) (P265GH), A105, FE 410 WB

AS 4087

DN 350 to 1200 (14 to 48"): 1.0044 (S275JR), 1.0425 (316L) (P265GH), A105

Seals

In accordance with DIN EN 1514-1

Accessories*Display protection*

Stainless steel 1.4301

Ground disks

1.4435 (316L), Alloy C22

Fitted electrodes

Measurement, reference and empty pipe detection electrodes available as standard with:

- 1.4435 (304L)
- Alloy C22

Process connections

Flange connections:

- EN 1092-1 (DIN 2501)
 - DN ≤ 300 (12"): lap joint flange (PN 10/16), lap joint flange, stamped plate (PN 10) = form A
 - DN ≥ 350 (14"): fixed flange (PN 6/10) = flat face
- ASME B16.5
 - DN ≤ 300 (12"): lap joint flange (Class 150)
 - DN ≥ 350 (14"): fixed flange (Class 150)
- AWWA C207
 - DN 1200 to 2200 (48 to 90"): fixed flange (Class D)
- AS 2129
 - DN 350 to 1200 (14 to 48"): fixed flange (Table E)
- AS 4087
 - DN 350 to 1200 (14 to 48"): fixed flange (PN 16)



For information on the materials of the process connections (→ 60)

Surface roughness

Electrodes with 1.4435 (304L), Alloy C22:
 ≤ 0.3 to 0.5 μm (11.8 to 19.7 in)
 (All data relate to parts in contact with fluid)

Operability

Operating concept

Operator-oriented menu structure for user-specific tasks

- Commissioning
- Operation
- Diagnostics
- Expert level

Rapid and safe commissioning

- Guided menus ("Make-it-run" wizards) for applications
- Menu guidance with brief explanations of the individual parameter functions

Reliable operation

- Operation in the following languages:
 - Via local display:
 - English, German, French, Spanish, Italian, Dutch, Portuguese, Polish, Russian, Turkish, Chinese, Japanese, Bahasa (Indonesian), Vietnamese, Czech
 - Via "FieldCare" operating tool:
 - English, German, French, Spanish, Italian, Dutch, Chinese, Japanese
 - Via Web browser:
 - English, German, French, Spanish, Italian, Dutch, Portuguese, Polish, Russian, Turkish, Chinese, Japanese, Bahasa (Indonesian), Vietnamese, Czech
- Uniform operating philosophy applied to device, operating tools and Web browser
- If replacing the electronic module, transfer the device configuration via the plug-in memory (HistoROM DAT) which contains the process and measuring device data and the event logbook. No need to reconfigure.

Efficient diagnostics increase measurement availability

- Troubleshooting measures can be called up via the device, operating tools and Web browser
- Diverse simulation options, logbook for events that occur and optional line recorder functions

Local operation

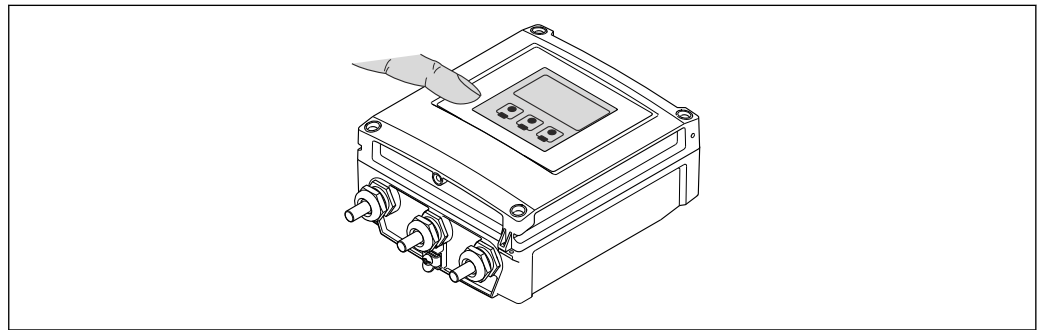

A0020538

Display elements

- 4-line display
- White background lighting; switches to red in event of device errors
- Format for displaying measured variables and status variables can be individually configured
- Permitted ambient temperature for the display: -20 to +50 °C (-4 to +122 °F)
The readability of the display may be impaired at temperatures outside the temperature range.

Operating elements

External operation via touch control; 3 optical keys:   

Additional functionality

- Data backup function
The device configuration can be saved in the display module.
- Data comparison function
The device configuration saved in the display module can be compared to the current device configuration.
- Data transfer function
The transmitter configuration can be transmitted to another device using the display module.

Remote operation

Via HART protocol

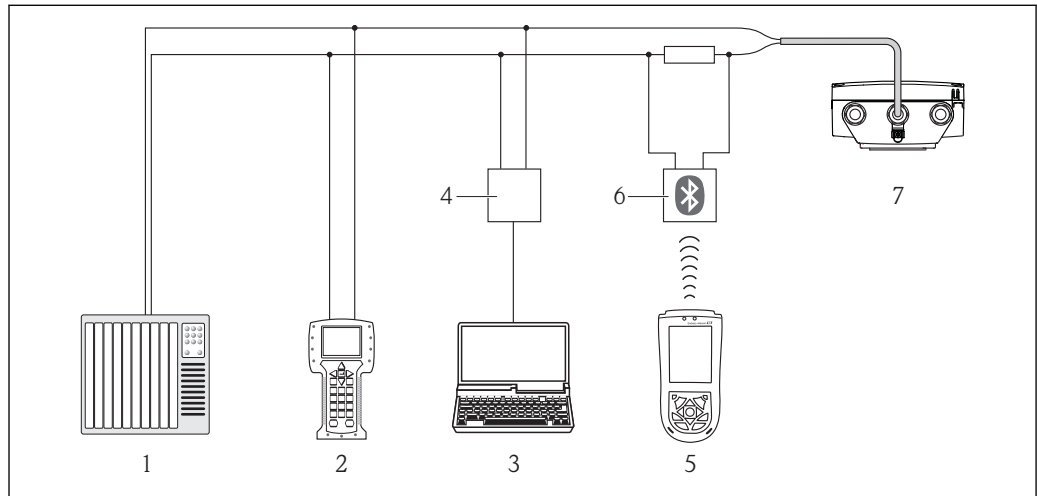

A0017124

28 Options for remote operation via HART protocol

- 1 Control system (e.g. PLC)
- 2 Field Communicator 475
- 3 Computer with operating tool (e.g. FieldCare, AMS Device Manager, SIMATIC PDM)
- 4 Commubox FXA195 (USB)
- 5 Field Xpert SFX100
- 6 VIATOR Bluetooth modem with connecting cable
- 7 Transmitter

Via service interface (CDI-RJ45)

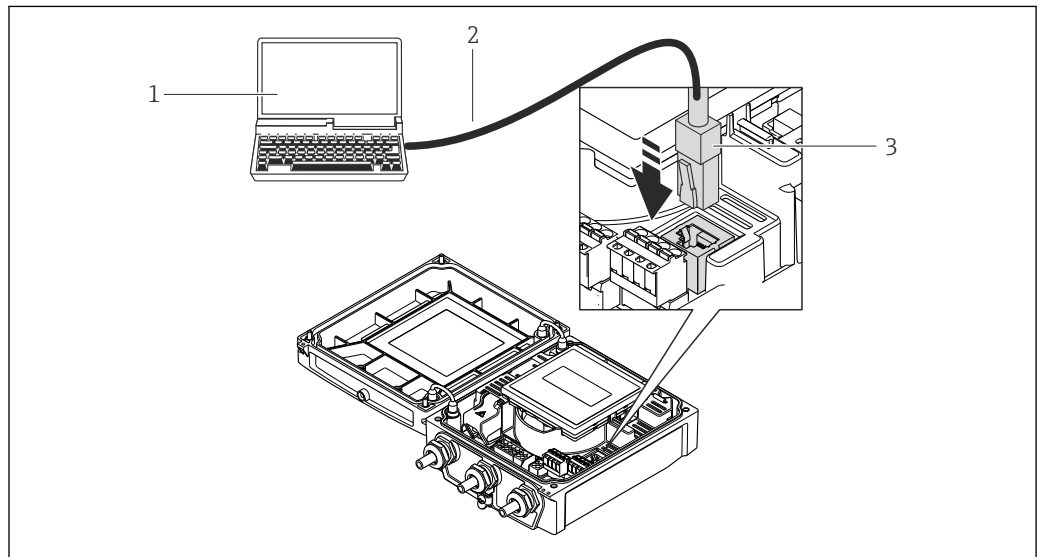

A0020481

- 1 Computer with Web browser (e.g. Internet Explorer) for accessing the integrated device Web server or with "FieldCare" operating tool with COM DTM "CDI Communication TCP/IP"
- 2 Standard Ethernet connecting cable with RJ45 plug
- 3 Service interface (CDI -RJ45) of the measuring device with access to the integrated Web server

Via Ethernet network

This communication interface is present in the following device version:
Order code for "Output", option N: EtherNet/IP

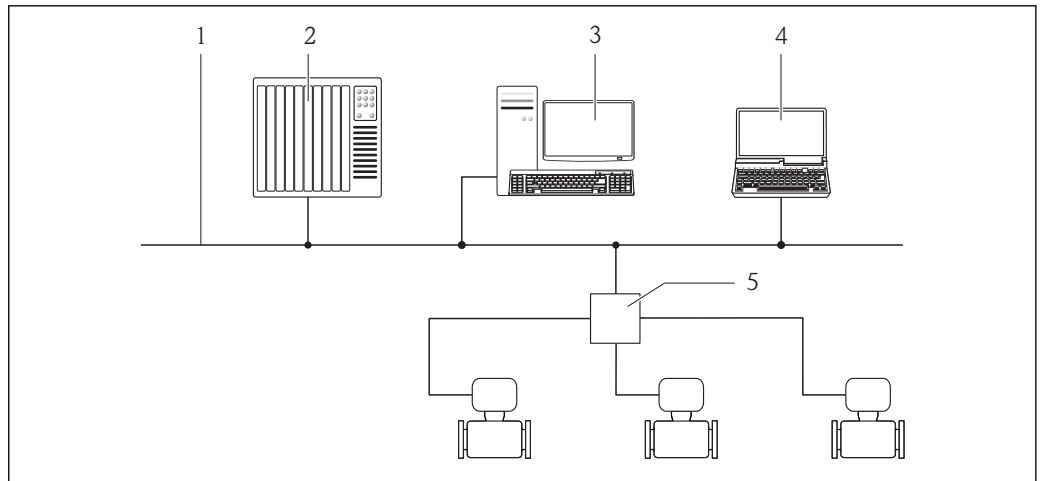

A0016961

- 1 Ethernet network
- 2 Automation system, e.g. "RSLogix" (Rockwell Automation)
- 3 Workstation for measuring device operation: with Add-on Profile Level 3 for "RSLogix 5000" (Rockwell Automation) or with Electronic Data Sheet (EDS)
- 4 Computer with Web browser (e.g. Internet Explorer) for accessing the integrated device Web server or with "FieldCare" operating tool with COM DTM "CDI Communication TCP/IP"
- 5 Ethernet switch

Certificates and approvals

CE mark	<p>The measuring system is in conformity with the statutory requirements of the applicable EC Directives. These are listed in the corresponding EC Declaration of Conformity along with the standards applied.</p> <p>Endress+Hauser confirms successful testing of the device by affixing to it the CE mark.</p>
C-Tick symbol	<p>The measuring system meets the EMC requirements of the "Australian Communications and Media Authority (ACMA)".</p>
Drinking water approval	<ul style="list-style-type: none"> ■ ACS ■ KTW/W270 ■ NSF 61 ■ WRAS BS 6920
EtherNet/IP certification	<p>The measuring device is certified and registered by the ODVA (Open Device Vendor Association). The measuring system meets all the requirements of the following specifications:</p> <ul style="list-style-type: none"> ■ Certified in accordance with the ODVA Conformance Test ■ EtherNet/IP Performance Test ■ EtherNet/IP PlugFest compliance ■ The device can also be operated with certified devices of other manufacturers (interoperability)
Other standards and guidelines	<ul style="list-style-type: none"> ■ EN 60529 Degrees of protection by housing (IP code) ■ EN 61010-1 Protection Measures for Electrical Equipment for Measurement, Control, Regulation and Laboratory Procedures. ■ IEC/EN 61326 Emission in accordance with Class A requirements. Electromagnetic compatibility (EMC requirements) ■ ANSI/ISA-61010-1 (82.02.01): 2004 Safety Requirements for Electrical Equipment for Measurement, Control and Laboratory Use - Part 1 General Requirements

- CAN/CSA-C22.2 No. 61010-1-04
Safety Requirements for Electrical Equipment for Measurement, Control and Laboratory Use - Part 1 General Requirements
- NAMUR NE 21
Electromagnetic compatibility (EMC) of industrial process and laboratory control equipment.
- NAMUR NE 32
Data Retention in the Event of a Power Failure in Field and Control Instruments with Microprocessors
- NAMUR NE 43
Standardization of the signal level for the breakdown information of digital transmitters with analog output signal.
- NAMUR NE 53
Software of field devices and signal-processing devices with digital electronics
- NAMUR NE 105
Specifications for Integrating Fieldbus Devices in Engineering Tools for Field Devices
- NAMUR NE 107
Self-monitoring and diagnosis of field devices
- NAMUR NE 131
Requirements for field devices for standard applications

Ordering information

Detailed ordering information is available from the following sources:

- In the Product Configurator on the Endress+Hauser website: www.endress.com → Select country → Instruments → Select device → Product page function: Configure this product
- From your Endress+Hauser Sales Center: www.endress.com/worldwide



Product Configurator - the tool for individual product configuration

- Up-to-the-minute configuration data
- Depending on the device: Direct input of measuring point-specific information such as measuring range or operating language
- Automatic verification of exclusion criteria
- Automatic creation of the order code and its breakdown in PDF or Excel output format
- Ability to order directly in the Endress+Hauser Online Shop

Application packages

Many different application packages are available to enhance the functionality of the device. Such packages might be needed to address safety aspects or specific application requirements.

The application packages can be ordered from Endress+Hauser either directly with the device or subsequently. Detailed information on the order code in question is available from your local Endress+Hauser sales center or on the product page of the Endress+Hauser website: www.endress.com.

Cleaning

Package	Description
Electrode cleaning circuit (ECC)	The electrode cleaning circuit (ECC) function has been developed to have a solution for applications where magnetite (Fe ₃ O ₄) deposits frequently occur (e.g. hot water). Since magnetite is highly conductive this build up leads to measuring errors and ultimately to the loss of signal. The option is designed to AVOID build up of highly conductive matter and thin layers (typically magnetite).

Diagnostics functions

Package	Description
HistoROM extended function	<p>Comprises extended functions concerning the event log and the activation of the measured value memory.</p> <p>Event log: Memory volume is extended from 20 message entries (basic version) to up to 100 entries.</p> <p>Data logging (line recorder):</p> <ul style="list-style-type: none"> ▪ Memory capacity for up to 1000 measured values is activated. ▪ 250 measured values can be output via each of the 4 memory channels. The recording interval can be defined and configured by the user. ▪ Data logging is visualized via the local display or FieldCare.

Heartbeat Technology

Package	Description
Heartbeat Verification +Monitoring	<p>Heartbeat Monitoring: Continuously supplies monitoring data, which are characteristic of the measuring principle, for an external condition monitoring system. This makes it possible to:</p> <ul style="list-style-type: none"> ▪ Draw conclusions - using these data and other information - about the impact the measuring application has on the measuring performance over time. ▪ Schedule servicing in time. ▪ Monitor the product quality, e.g. gas pockets. <p>Heartbeat Verification: Makes it possible to check the device functionality on demand when the device is installed, without having to interrupt the process.</p> <ul style="list-style-type: none"> ▪ Access via onsite operation or other interfaces (requires no on-site presence). ▪ End-to-end, traceable documentation of the verification results and verification report. ▪ Extension of calibration intervals.

Accessories

Various accessories, which can be ordered with the device or subsequently from Endress+Hauser, are available for the device. Detailed information on the order code in question is available from your local Endress+Hauser sales center or on the product page of the Endress+Hauser website: www.endress.com.

Device-specific accessories







For the transmitter

Accessories	Description
Display protection	<p>Is used to protect the display against impact or scoring from sand in desert areas.</p> <p> For details, see Special Documentation SD00333F</p>
Connecting cable for remote version	Coil current and electrode cables, various lengths, reinforced cables available on request.
Ground cable	Set, consisting of two ground cables for potential equalization.
Pipe mounting set	Pipe mounting set for transmitter.
Compact → remote conversion kit	For converting a compact device version to a remote device version.
Promag 50/53 → Promag 400 conversion kit	For converting a Promag with transmitter 50/53 to a Promag 400.

For the sensor

Accessories	Description
Ground disks	<p>Are used to ground the fluid in lined measuring tubes to ensure proper measurement.</p> <p> For details, see Installation Instructions EA00070D</p>

Communication-specific accessories

Accessories	Description
Commubox FXA195 HART	<p>For intrinsically safe HART communication with FieldCare via the USB interface.</p> <p> For details, see "Technical Information" TI00404F</p>
HART Loop Converter HMX50	<p>Is used to evaluate and convert dynamic HART process variables to analog current signals or limit values.</p> <p> For details, see "Technical Information" TI00429F and Operating Instructions BA00371F</p>
Wireless HART adapter SWA70	<p>Is used for the wireless connection of field devices. The WirelessHART adapter can be easily integrated into field devices and existing infrastructures, offers data protection and transmission safety and can be operated in parallel with other wireless networks with minimum cabling complexity.</p> <p> For details, see Operating Instructions BA00061S</p>
Fieldgate FXA320	<p>Gateway for the remote monitoring of connected 4-20 mA measuring devices via a Web browser.</p> <p> For details, see "Technical Information" TI00025S and Operating Instructions BA00053S</p>
Fieldgate FXA520	<p>Gateway for the remote diagnostics and remote configuration of connected HART measuring devices via a Web browser.</p> <p> For details, see "Technical Information" TI00025S and Operating Instructions BA00051S</p>
Field Xpert SFX100	<p>Compact, flexible and robust industry handheld terminal for remote configuration and for obtaining measured values via the HART current output (4-20 mA).</p> <p> For details, see Operating Instructions BA00060S</p>

Service-specific accessories

Accessories	Description
Applicator	<p>Software for selecting and sizing Endress+Hauser measuring devices:</p> <ul style="list-style-type: none"> ■ Calculation of all the necessary data for identifying the optimum flowmeter: e.g. nominal diameter, pressure loss, accuracy or process connections. ■ Graphic illustration of the calculation results <p>Administration, documentation and access to all project-related data and parameters over the entire life cycle of a project.</p> <p>Applicator is available:</p> <ul style="list-style-type: none"> ■ Via the Internet: https://wapps.endress.com/applicator ■ On CD-ROM for local PC installation.

W@M	<p>Life cycle management for your plant</p> <p>W@M supports you with a wide range of software applications over the entire process: from planning and procurement, to the installation, commissioning and operation of the measuring devices. All the relevant device information, such as the device status, spare parts and device-specific documentation, is available for every device over the entire life cycle.</p> <p>The application already contains the data of your Endress+Hauser device. Endress+Hauser also takes care of maintaining and updating the data records.</p> <p>W@M is available:</p> <ul style="list-style-type: none"> ▪ Via the Internet: www.endress.com/lifecyclemanagement ▪ On CD-ROM for local PC installation.
FieldCare	<p>FDT-based plant asset management tool from Endress+Hauser. It can configure all smart field units in your system and helps you manage them. By using the status information, it is also a simple but effective way of checking their status and condition.</p> <p> For details, see Operating Instructions BA00027S and BA00059S</p>

System components

Accessories	Description
Memograph M graphic display recorder	<p>The Memograph M graphic data manager provides information on all the relevant measured variables. Measured values are recorded correctly, limit values are monitored and measuring points analyzed. The data are stored in the 256 MB internal memory and also on a SD card or USB stick.</p> <p> For details, see "Technical Information" TI00133R and Operating Instructions BA00247R</p>

Documentation



The following document types are available:

- On the CD-ROM supplied with the device
- In the Download Area of the Endress+Hauser Internet site: www.endress.com → Download

Standard documentation

Communication	Document type	Documentation code
HART	Operating Instructions	BA01062D
EtherNet/IP	Operating Instructions	BA01213D
- - -	Brief Operating Instructions	KA01113D

Supplementary device-dependent documentation

Document type	Approval	Documentation code
Special Documentation	Heartbeat Technology	SD01183D
Installation Instructions		Specified for each individual accessory (→  65)

Registered trademarks

HART®

Registered trademark of the HART Communication Foundation, Austin, USA

EtherNet/IP™

Trademark of ODVA, Inc.

Microsoft®

Registered trademark of the Microsoft Corporation, Redmond, Washington, USA

Applicator®, FieldCare®, Field Xpert™, HistoROM®, Heartbeat Technology™

Registered or registration-pending trademarks of the Endress+Hauser Group

www.addresses.endress.com
