



Level



Pressure



Flow



Temperature



Liquid  
Analysis



Registration



Systems  
Components



Services



Solutions

## Operating Instructions

# Proline t-mass B 150

## HART

### Thermal Mass Flow Measuring System

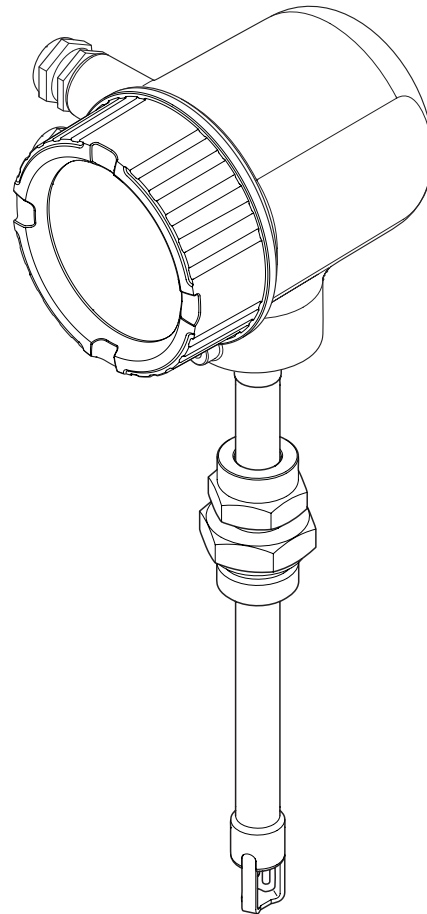

- Make sure the document is stored in a safe place such that it is always available when working on or with the device.
- To avoid danger to individuals or the facility, read the "Basic safety instructions" section carefully, as well as all other safety instructions in the document that are specific to working procedures.
- The manufacturer reserves the right to modify technical data without prior notice. Your Endress +Hauser distributor will supply you with current information and updates to these Instructions.

## Table of contents

<b>1</b>	<b>Document information</b>	<b>5</b>	<b>7</b>	<b>Electrical connection</b>	<b>23</b>
1.1	Document function	5	7.1	Connection conditions	23
1.2	Document conventions	5	7.1.1	Required tools	23
1.2.1	Safety symbols	5	7.1.2	Requirements for connecting cable	23
1.2.2	Electrical symbols	5	7.1.3	Requirements for the supply unit	23
1.2.3	Tool symbols	5	7.1.4	Terminal assignment	23
1.2.4	Symbols for certain types of information	6	7.1.5	Preparing the measuring device	24
1.2.5	Symbols in graphics	6	7.2	Connecting the measuring device	24
1.3	Documentation	7	7.2.1	Connecting the cables	25
1.3.1	Standard documentation	7	7.3	Ensuring the degree of protection	25
1.3.2	Supplementary device-dependent documentation	7	7.4	Post-connection check	26
<b>2</b>	<b>Basic safety instructions</b>	<b>8</b>	<b>8</b>	<b>Operation options</b>	<b>27</b>
2.1	Requirements for the personnel	8	8.1	Overview of operation options	27
2.2	Designated use	8	8.2	Structure and function of the operating menu	27
2.3	Workplace safety	9	8.2.1	Structure of the operating menu	27
2.4	Operational safety	9	8.2.2	Operating philosophy	29
2.5	Product safety	9	8.3	Access to the operating menu via the local display	30
<b>3</b>	<b>Product description</b>	<b>10</b>	8.3.1	Operational display	30
3.1	Product design	10	8.3.2	Navigation view	32
3.2	Registered trademarks	10	8.3.3	Editing view	34
<b>4</b>	<b>Incoming acceptance and product identification</b>	<b>11</b>	8.3.4	Operating elements	35
4.1	Incoming acceptance	11	8.3.5	Opening the context menu	36
4.2	Product identification	12	8.3.6	Navigating and selecting from list	38
4.2.1	Transmitter nameplate	12	8.3.7	Calling the parameter directly	38
4.2.2	Sensor nameplate	13	8.3.8	Calling up help text	39
<b>5</b>	<b>Storage and transport</b>	<b>14</b>	8.3.9	Changing the parameters	40
5.1	Storage conditions	14	8.3.10	User roles and related access authorization	41
5.2	Transporting the product	14	8.3.11	Disabling write protection via access code	41
5.3	Packaging disposal	14	8.3.12	Enabling and disabling the keypad lock	41
<b>6</b>	<b>Installation</b>	<b>15</b>	8.4	Access to the operating menu via the operating tool	43
6.1	Installation conditions	15	8.4.1	Field Xpert SFX100	43
6.1.1	Mounting position	15	8.4.2	FieldCare	43
6.1.2	Requirements from environment and process	19	8.4.3	AMS Device Manager	43
6.2	Mounting the measuring device	20	8.4.4	SIMATIC PDM	44
6.2.1	Required tools	20	8.4.5	Field Communicator 475	44
6.2.2	Preparing the measuring device	20	8.4.6	Connecting operating tools	44
6.2.3	Mounting the measuring device	20	<b>9</b>	<b>System integration</b>	<b>46</b>
6.2.4	Turning the transmitter housing	21	9.1	Overview of device description files	46
6.2.5	Turning the display module	21	9.1.1	Current version data for the device	46
6.3	Post-mounting check	22	9.1.2	Operating tools	46
			9.2	Measured variables via HART protocol	46
			9.3	Other settings	47
			<b>10</b>	<b>Commissioning</b>	<b>48</b>
			10.1	Function check	48
			10.2	Switching on the measuring device	48
			10.3	Setting the operating language	48

10.4	Configuring the measuring device . . . . .	49	<b>13</b>	<b>Repair . . . . .</b>	<b>93</b>
10.4.1	Selecting the gas type . . . . .	50	13.1	General notes . . . . .	93
10.4.2	Specifying the process pressure . . . . .	50	13.2	Spare parts . . . . .	93
10.4.3	Configuring the sensor data . . . . .	51	13.3	Endress+Hauser services . . . . .	93
10.4.4	Determining the installation factor . . . . .	51	<b>14</b>	<b>Maintenance . . . . .</b>	<b>94</b>
10.4.5	Configuring the current output . . . . .	53	14.1	Maintenance tasks . . . . .	94
10.4.6	Configuring the pulse/frequency/switch output . . . . .	53	14.1.1	Exterior cleaning . . . . .	94
10.5	Advanced settings . . . . .	55	14.1.2	Interior cleaning . . . . .	94
10.5.1	Defining the tag name . . . . .	56	14.2	Measuring and test equipment . . . . .	94
10.5.2	Configuring applications . . . . .	56	14.3	Endress+Hauser services . . . . .	94
10.5.3	Setting the system units . . . . .	57	<b>15</b>	<b>Return . . . . .</b>	<b>95</b>
10.5.4	Configuring the current output . . . . .	59	<b>16</b>	<b>Disposal . . . . .</b>	<b>96</b>
10.5.5	Configuring the PFS output . . . . .	62	16.1	Removing the measuring device . . . . .	96
10.5.6	Configuring the output conditioning . . . . .	67	16.2	Disposing of the measuring device . . . . .	96
10.5.7	Configuring the low flow cut off . . . . .	68	<b>17</b>	<b>Technical data . . . . .</b>	<b>97</b>
10.5.8	Configuring the totalizer . . . . .	69	17.1	Application . . . . .	97
10.5.9	Configuring the local display . . . . .	69	17.2	Function and system design . . . . .	97
10.6	Configuration management . . . . .	71	17.3	Characteristic values . . . . .	97
10.7	Simulation . . . . .	72	17.4	Output . . . . .	99
10.8	Protecting settings from unauthorized access . . . . .	73	17.5	Power supply . . . . .	102
10.8.1	Write protection via access code . . . . .	74	17.6	Performance characteristics . . . . .	104
10.8.2	Write protection via write protection switch . . . . .	74	17.7	Installation . . . . .	105
<b>11</b>	<b>Operation . . . . .</b>	<b>77</b>	17.8	Environment . . . . .	105
11.1	Adjusting the operating language . . . . .	77	17.9	Process . . . . .	106
11.2	Configuring the display . . . . .	77	17.10	Mechanical construction . . . . .	106
11.2.1	Navigation path . . . . .	77	17.11	Operability . . . . .	108
11.2.2	Parameter overview with brief description . . . . .	77	17.12	Certificates and approvals . . . . .	110
11.3	Reading measured values . . . . .	77	17.13	Accessories . . . . .	111
11.3.1	Process variables . . . . .	77	17.14	Documentation . . . . .	111
11.3.2	Totalizer . . . . .	78	<b>18</b>	<b>Appendix . . . . .</b>	<b>112</b>
11.3.3	Output values . . . . .	79	18.1	Overview of the Operator/Maintenance operating menu . . . . .	112
11.4	Adapting the measuring device to the process conditions . . . . .	80	<b>Index . . . . .</b>	<b>130</b>	
11.5	Performing a totalizer reset . . . . .	80			
11.6	Showing data logging . . . . .	81			
<b>12</b>	<b>Diagnostics and troubleshooting . . . . .</b>	<b>82</b>			
12.1	General troubleshooting . . . . .	82			
12.2	Diagnostic information on local display . . . . .	84			
12.2.1	Diagnostic message . . . . .	84			
12.2.2	Calling up remedial measures . . . . .	86			
12.3	Diagnostic information in the operating tool . . . . .	86			
12.4	Adapting the diagnostic information . . . . .	87			
12.4.1	Adapting the diagnostic behavior . . . . .	87			
12.5	Overview of diagnostic information . . . . .	88			
12.6	Resetting the measuring device . . . . .	90			
12.7	Diagnostics list . . . . .	90			
12.8	Event logbook . . . . .	90			
12.8.1	Event history . . . . .	90			
12.8.2	Filtering the event logbook . . . . .	91			
12.8.3	Overview of information events . . . . .	91			





# 1 Document information

## 1.1 Document function





These Operating Instructions contain all the information that is required in various phases of the life cycle of the device: from product identification, incoming acceptance and storage, to mounting, connection, operation and commissioning through to troubleshooting, maintenance and disposal.

## 1.2 Document conventions



### 1.2.1 Safety symbols



Symbol	Meaning
 A0011189-EN	<b>DANGER!</b> This symbol alerts you to a dangerous situation. Failure to avoid this situation will result in serious or fatal injury.
 A0011190-EN	<b>WARNING!</b> This symbol alerts you to a dangerous situation. Failure to avoid this situation can result in serious or fatal injury.
 A0011191-EN	<b>CAUTION!</b> This symbol alerts you to a dangerous situation. Failure to avoid this situation can result in minor or medium injury.
 A0011192-EN	<b>NOTICE!</b> This symbol contains information on procedures and other facts which do not result in personal injury.

### 1.2.2 Electrical symbols





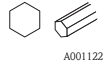





Symbol	Meaning
 A0011197	<b>Direct current</b> A terminal to which DC voltage is applied or through which direct current flows.
 A0011198	<b>Alternating current</b> A terminal to which alternating voltage (sine-wave) is applied or through which alternating current flows.
 A0011200	<b>Ground connection</b> A grounded terminal which, as far as the operator is concerned, is grounded via a grounding system.
 A0011199	<b>Protective ground connection</b> A terminal which must be connected to ground prior to establishing any other connections.
 A0011201	<b>Equipotential connection</b> A connection that has to be connected to the plant grounding system: This may be a potential equalization line or a star grounding system depending on national or company codes of practice.

### 1.2.3 Tool symbols





Symbol	Meaning
 A0013442	Torx screwdriver
 A0011220	Flat blade screwdriver

Symbol	Meaning
 A0011219	Phillips head screwdriver
 A0011221	Allen key
 A0011222	Hexagon wrench

### 1.2.4 Symbols for certain types of information

Symbol	Meaning
 A0011182	<b>Allowed</b> Indicates procedures, processes or actions that are allowed.
 A0011183	<b>Preferred</b> Indicates procedures, processes or actions that are preferred.
 A0011184	<b>Forbidden</b> Indicates procedures, processes or actions that are forbidden.
 A0011193	<b>Tip</b> Indicates additional information.
 A0011194	<b>Reference to documentation</b> Refers to the corresponding device documentation.
 A0011195	<b>Reference to page</b> Refers to the corresponding page number.
 A0011196	<b>Reference to graphic</b> Refers to the corresponding graphic number and page number.
	<b>Series of steps</b>
	<b>Result of a sequence of actions</b>
 A0013562	<b>Help in the event of a problem</b>

### 1.2.5 Symbols in graphics

Symbol	Meaning
<b>1, 2, 3,...</b>	Item numbers
	Series of steps
<b>A, B, C, ...</b>	Views
<b>A-A, B-B, C-C, ...</b>	Sections
 A0013441	Flow direction
 A0011187	<b>Hazardous area</b> Indicates a hazardous area.
 A0011188	<b>Safe area (non-hazardous area)</b> Indicates a non-hazardous location.

## 1.3 Documentation

### 1.3.1 Standard documentation

Document type	Purpose and content of the document
Technical Information	<b>Planning aid for your device</b> The document contains all the technical data on the device and provides an overview of the accessories and other products that can be ordered for the device.
Brief Operating Instructions	<b>Guide that takes you quickly to the 1st measured value</b> The Brief Operating Instructions contain all the essential information from incoming acceptance to initial commissioning.



The document types listed are available:

- On the CD-ROM supplied with the device
- In the Download Area of the Endress+Hauser Internet site: [www.endress.com](http://www.endress.com) → Download

### 1.3.2 Supplementary device-dependent documentation

If the device is being used in a hazardous location: Instructions in the relevant supplementary documentation must be consistently observed. The supplementary documentation is an integral part of the device documentation.

Document type	Device particularities and document content
Safety Instructions	<b>Operation in hazardous areas</b> The document contains all the necessary information for the safe operation of the device in hazardous areas, and explains how the device can be identified as an Ex system from the device nameplate.
Installation Instructions	<b>Ordered accessory</b> The Installation Instructions contain all the information needed to install the ordered accessory or spare part.



The document types listed are available:

- On the CD-ROM supplied with the device
- In the Download Area of the Endress+Hauser Internet site: [www.endress.com](http://www.endress.com) → Download

## 2 Basic safety instructions

### 2.1 Requirements for the personnel

The personnel for installation, commissioning, diagnostics and maintenance must fulfill the following requirements:

- ▶ Trained, qualified specialists must have a relevant qualification for this specific function and task
- ▶ Are authorized by the plant owner/operator
- ▶ Are familiar with federal/national regulations
- ▶ Before beginning work, the specialist staff must have read and understood the instructions in the Operating Instructions and supplementary documentation as well as in the certificates (depending on the application)
- ▶ Following instructions and basic conditions

The operating personnel must fulfill the following requirements:

- ▶ Being instructed and authorized according to the requirements of the task by the facility's owner-operator
- ▶ Following the instructions in these Operating Instructions

### 2.2 Designated use

#### Application and media

The measuring device described in these Instructions is intended only for flow measurement of gases.

To ensure that the measuring device remains in proper condition for the operation time:

- ▶ Only use the measuring device in full compliance with the data on the nameplate and the general conditions listed in the Operating Instructions and supplementary documentation.
- ▶ Based on the nameplate, check whether the ordered device is permitted for the intended use in the hazardous area (e.g. explosion protection, pressure vessel safety).
- ▶ Use the measuring device only for media against which the process-wetted materials are adequately resistant.

#### Incorrect use

The manufacturer is not liable for damage caused by improper or non-designated use.

#### **⚠ WARNING**

**Risk of injury if the process connection and sensor gland are opened under pressure.**

- ▶ The process connection and the sensor gland should only be opened in an unpressurized state.

#### **NOTICE**

**Dust and moisture can enter the transmitter when the transmitter housing is opened.**

- ▶ Only open the transmitter housing briefly, ensuring that no dust or moisture enters the housing.

#### **NOTICE**

**Danger of breakage of the sensor due to corrosive or abrasive fluids!**

- ▶ Verify the compatibility of the process fluid with the sensor material.
- ▶ Ensure the resistance of all fluid-wetted materials in the process.
- ▶ Observe the specified maximum process pressure.

Verification for borderline cases:

- ▶ For special fluids and fluids for cleaning, Endress+Hauser is glad to provide assistance in verifying the corrosion resistance of fluid-wetted materials, but does not accept any warranty or liability.



**Residual risks**

The external surface temperature of the housing can increase by max. 15 K due to the power consumption of the electronic components. Hot process fluids passing through the measuring device will further increase the surface temperature of the housing. The surface of the sensor, in particular, can reach temperatures which are close to the fluid temperature.

Possible burn hazard due to fluid temperatures!

- ▶ For elevated fluid temperature, ensure protection against contact to prevent burns.

## 2.3 Workplace safety

For work on and with the device:

- ▶ Wear the required personal protective equipment according to federal/national regulations.

For welding work on the piping:

- ▶ Do not ground the welding unit via the measuring device.

## 2.4 Operational safety

Risk of injury.

- ▶ Operate the device in proper technical condition and fail-safe condition only.
- ▶ The operator is responsible for interference-free operation of the device.

**Conversions to the device**

Unauthorized modifications to the device are not permitted and can lead to unforeseeable dangers.

- ▶ If, despite this, modifications are required, consult with Endress+Hauser.

**Repair**

To ensure continued operational safety and reliability,

- ▶ Carry out repairs on the device only if they are expressly permitted.
- ▶ Observe federal/national regulations pertaining to repair of an electrical device.
- ▶ Use original spare parts and accessories from Endress+Hauser only.

## 2.5 Product safety

This measuring device is designed in accordance with good engineering practice to meet state-of-the-art safety requirements, has been tested, and left the factory in a condition in which they are safe to operate.

It meets general safety standards and legal requirements. It also complies with the EC directives listed in the device-specific EC Declaration of Conformity. Endress+Hauser confirms this by affixing the CE mark to the device.

## 3 Product description

### 3.1 Product design

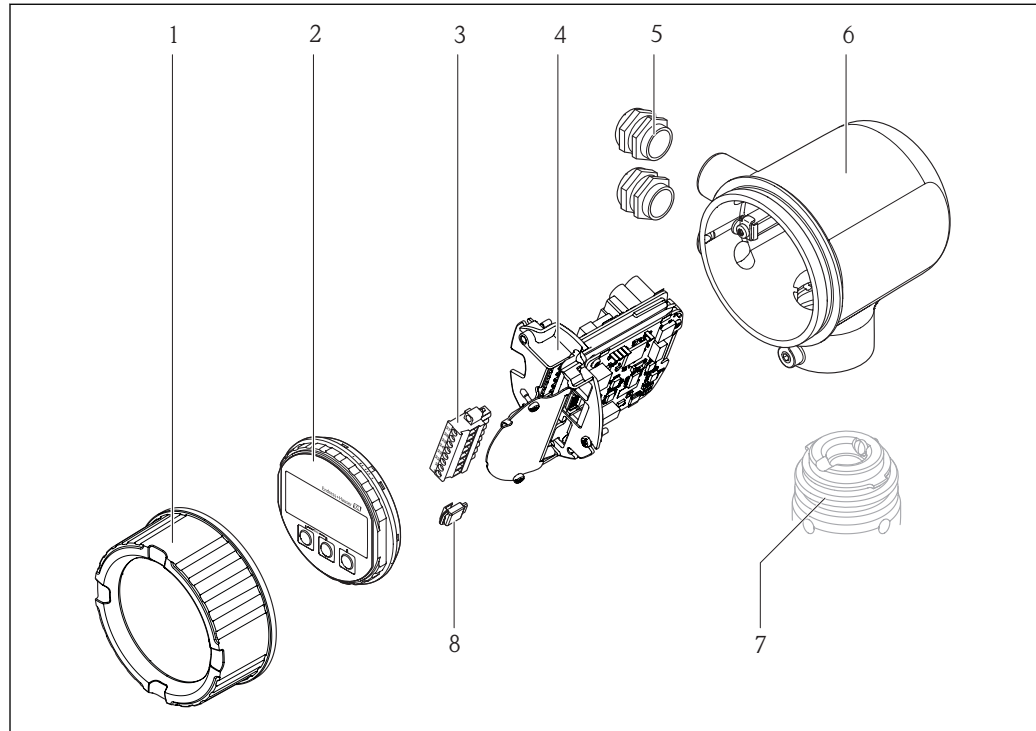

A0017196

- 1 Electronics compartment cover
- 2 Display module
- 3 Terminal block
- 4 Electronics module
- 5 Cable gland
- 6 Transmitter housing
- 7 Sensor
- 8 S-DAT

### 3.2 Registered trademarks

#### **HART®**

Registered trademark of the HART Communication Foundation, Austin, USA

#### **Applicator®, FieldCare®, Field Xpert™, HistoROM®**

Registered or registration-pending trademarks of the Endress+Hauser Group

# 4 Incoming acceptance and product identification

## 4.1 Incoming acceptance

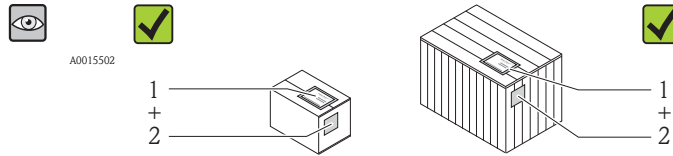

A0013843

Is the order code on the delivery note (1) identical to the order code on the product sticker (2)?

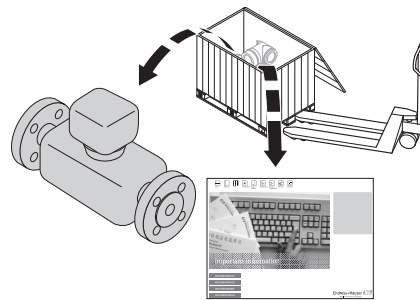

A0013695

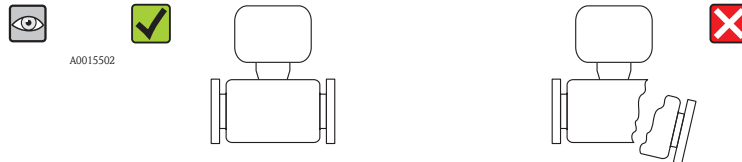

A0013698

Are the goods undamaged?

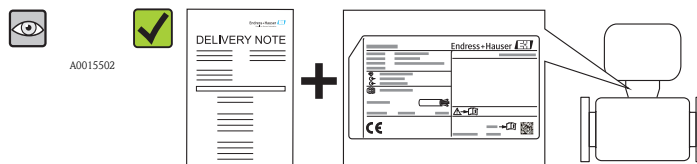

A0013699

Do the nameplate data match the ordering information on the delivery note?

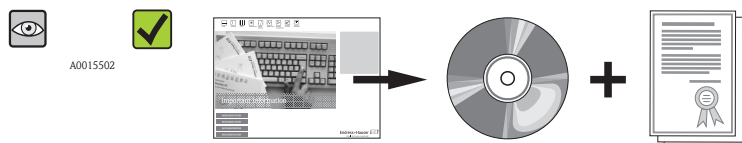

A0013697

Is the CD-ROM with the Technical Documentation and documents present?



 If one of the conditions does not comply, contact your Endress+Hauser distributor.

## 4.2 Product identification

The following options are available for identification of the measuring device:

- Nameplate specifications
- Order code with breakdown of the device features on the delivery note
- Enter serial numbers from nameplates in *W@M Device Viewer* ([www.endress.com/deviceviewer](http://www.endress.com/deviceviewer)): All information about the measuring device is displayed.

For an overview of the scope of the Technical Documentation provided, refer to the following:

- The chapters "Additional standard documentation on the device" (→  7) and "Supplementary device-dependent documentation" (→  7)
- The *W@M Device Viewer*: Enter the serial number from the nameplate ([www.endress.com/deviceviewer](http://www.endress.com/deviceviewer))

### 4.2.1 Transmitter nameplate

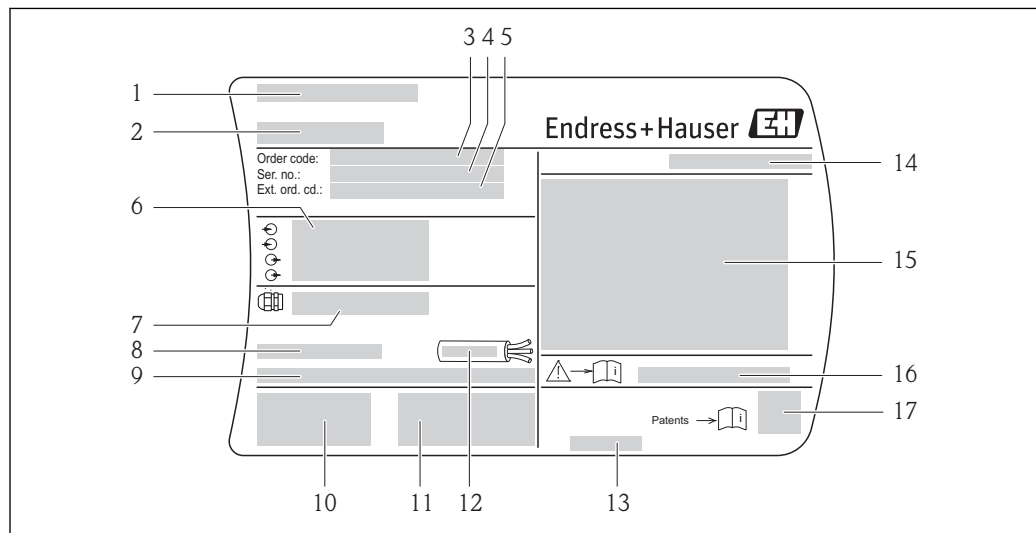

 1 Example of a transmitter nameplate

- 1 Manufacturing location
- 2 Name of the transmitter
- 3 Order code
- 4 Serial number (Ser. no.)
- 5 Extended order code (Ext. ord. cd.)
- 6 Electrical connection data, e.g. available inputs and outputs, supply voltage
- 7 Type of cable glands
- 8 Permitted ambient temperature ( $T_a$ )
- 9 Firmware version (FW) and device revision (Dev.Rev.) from the factory
- 10 CE mark, C-Tick
- 11 Additional information on version: certificates, approvals
- 12 Permitted temperature range for cable
- 13 Manufacturing date: year-month
- 14 Degree of protection
- 15 Approval information for explosion protection
- 16 Document number of safety-related supplementary documentation (→  7)
- 17 2-D matrix code

## 4.2.2 Sensor nameplate

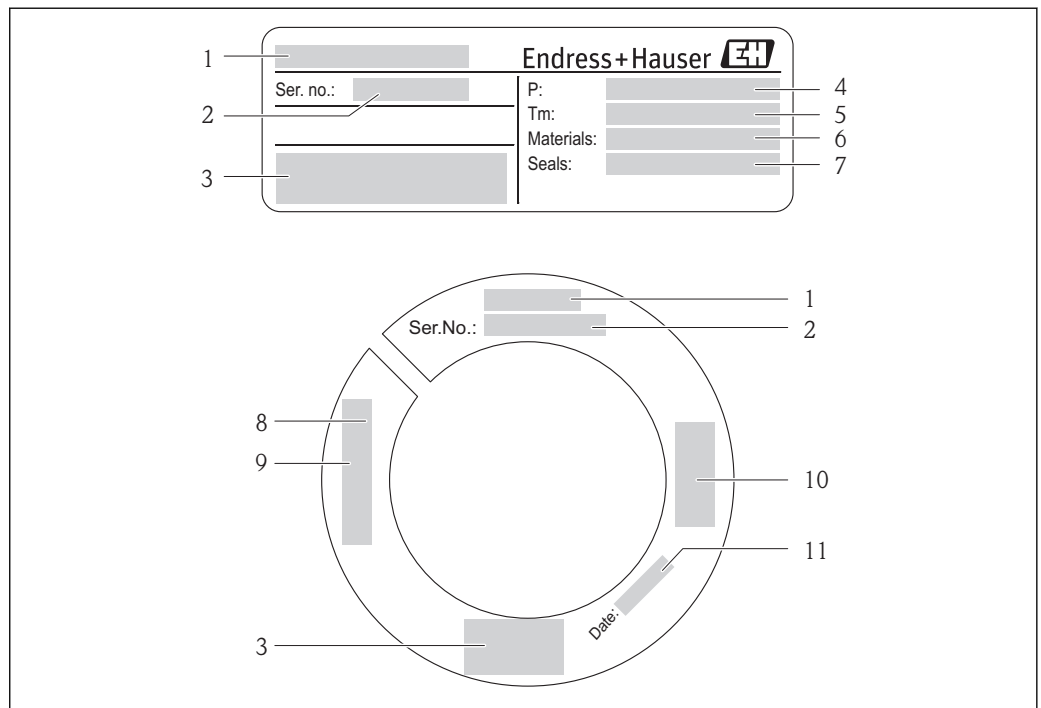

A0017233

 2 Example of 1st sensor nameplate

- 1 Name of the sensor
- 2 Serial number (Ser. no.)
- 3 CE mark, C-Tick
- 4 Process pressure range
- 5 Medium temperature range
- 6 Measuring tube material
- 7 Seal material
- 8 Thread data
- 9 Sensor length
- 10 Approval information for Pressure Equipment Directive
- 11 Manufacturing date: year-month

### Order code

The measuring device is reordered using the order code.

#### Extended order code

- The device type (product root) and basic specifications (mandatory features) are always listed.
- Of the optional specifications (optional features), only the safety and approval-related specifications are listed (e.g. LA). If other optional specifications have also been ordered, they are indicated collectively by the placeholder symbol "#" (e.g. #LA#).
- If the ordered optional specifications do not include any safety and approval-related specifications, they are indicated by the + placeholder symbol (e.g. XXXXXX-ABCDE+).

## 5 Storage and transport

### 5.1 Storage conditions

Observe the following notes for storage:

- Store in the original packaging to ensure protection from shock.
- Do not remove the protection cap mounted on the transducer. It prevents mechanical damage and contamination in the measuring tube.
- Protect from direct sunlight to avoid unacceptably high surface temperatures.
- Select a storage location where moisture cannot collect in the measuring device as fungus and bacteria infestation can damage the lining.
- Store in a dry and dust-free place.
- Do not store outdoors.
- Storage temperature(→  19)

### 5.2 Transporting the product

Observe the following notes during transport:

- Transport the measuring device to the measuring point in the original packaging.
- Do not remove the protection cap mounted on the transducer. It prevents mechanical damage and contamination.

### 5.3 Packaging disposal

All packaging materials are environmentally friendly and 100% recyclable:

- Measuring device secondary packaging: polymer stretch film that conforms to EC Directive 2002/95/EC (RoHS).
- Packaging:
  - Wood crate, treated in accordance with ISPM 15 standard, which is confirmed by the affixed IPPC logo.
  - or
  - Carton in accordance with European Packaging Directive 94/62EC; recyclability is confirmed by the affixed RESY symbol.
- Seaworthy packaging (optional): Wood crate, treated in accordance with ISPM 15 standard, which is confirmed by the affixed IPPC logo.
- Carrying and mounting hardware:
  - Disposable plastic pallet
  - Plastic straps
  - Plastic adhesive strips
- Dunnage: Paper cushion

## 6 Installation

### 6.1 Installation conditions

For mechanical reasons and to protect the pipe, support is recommended for heavy sensors (e.g. with a hot-tap retractable assembly).

#### 6.1.1 Mounting position

##### Mounting location

**Thermal measuring devices require a fully developed flow profile as a prerequisite for correct flow measurement. For this reason, please pay attention to the following points and document sections when installing the device:**

- Avoid flow disturbances, as the thermal measuring principle reacts sensitively to them.
- Take measures to avoid condensation (e.g. condensation trap, thermal insulation etc.).
- For mechanical reasons and to protect the pipe, support is recommended for heavy sensors (e.g. when installing a Hot tap extraction assembly).

##### Orientation

The direction of the arrow on the sensor helps you to install the sensor according to the flow direction (direction of medium flow through the piping).

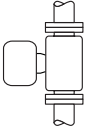
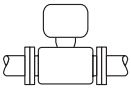
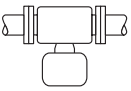
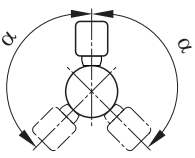
	Orientation	Recommendation
Vertical orientation	 A0017337	✓ <sup>1) 2)</sup>
Horizontal orientation, transmitter head up	 A0015589	✓✓
Horizontal orientation, transmitter head down	 A0015590	✓✓ <sup>3)</sup>
Inclined mounting position, transmitter head down	 A0015773	✓ <sup>4)</sup>

- 1) In the case of saturated or unclean gases, upward flow in a vertical pipe section is preferred to minimize condensation or contamination.
- 2) Not recommended in the case of extreme vibrations or unstable installations.
- 3) Suitable only for clean and dry gases. If buildup or condensate are always present: Mount the sensor in an inclined position.
- 4) Select inclined mounting position ( $\alpha = \text{approx. } 135^\circ$ ) if the gas is very wet or saturated with water.

### Requirement for pipework

**The measuring device must be professionally installed, and the following points must be observed:**

- Piping must be professionally welded.
- Seals must be sized correctly.
- Flanges and seals must be correctly aligned.
- The internal diameter of the pipe must be known. The maximum permitted deviation from the input value is:
  - 1 mm (0.04 in) at DN < 200 mm (8 in)
  - 3 mm (0.12 in) at DN ≥ 200 mm (8 in)
- Following installation, the pipe must be free from dirt and particles in order to avoid damage to the sensors.

Further information → ISO standard 14511

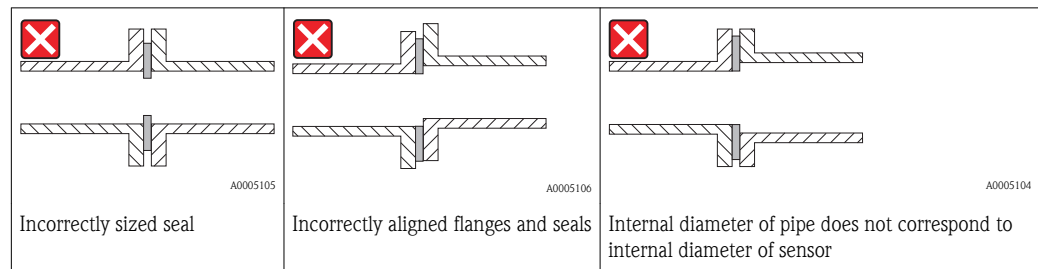

### Choosing the sensor length

The minimum length of the sensor can be calculated using the Endress+Hauser calculation program Applicator (from version 10.00) or using the following calculation.

The minimum length of the sensor is determined by the required insertion depth. The required insertion depth that is calculated must be within the adjusting range of the selected insertion version.

- ▶ Determining the dimensions A, B, C1 and C2



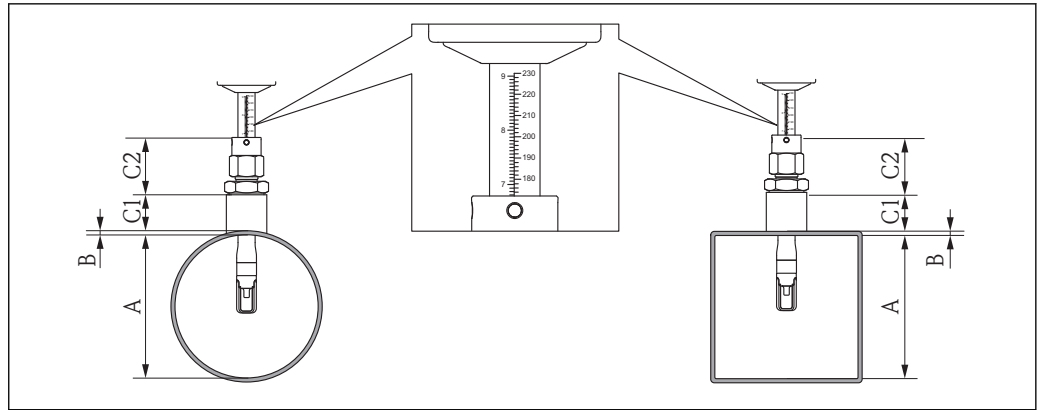

A0015768

- A Internal pipe diameter DN (circular pipe) or internal dimension (rectangular duct)
- B Thickness of pipe wall or of duct wall
- C1 Length of mounting set
- C2 Length of sensor compression fitting

*Determining C1 and C2 (Endress+Hauser original parts only)*

DK6MB-BXA mounting boss G1A	C1 + C2 = 99 mm (3.90 in)
DK6MB-DXA mounting boss G3/4A	C1 + C2 = 99 mm (3.90 in)
DK6MB-AXA mounting boss 1" NPT	C1 + C2 = 107 mm (4.21 in)
DK6MB-CXA mounting boss 3/4" NPT	C1 + C2 = 102 mm (4.02 in)

*Determining C1 and C2 (not limited to Endress+Hauser original parts)*

C1	Length of pipe connection used
C2 (compression fitting with G1A thread)	39 mm (1.54 in)
C2 (compression fitting with G3/4A thread)	39 mm (1.54 in)
C2 (compression fitting with 1" NPT thread)	47 mm (1.85 in)
C2 (compression fitting with 3/4" NPT thread)	42 mm (1.65 in)

► Calculating insertion depth

$$(0.3 \cdot A) + B + (C1 + C2)$$

**Mounting conditions for mounting boss**

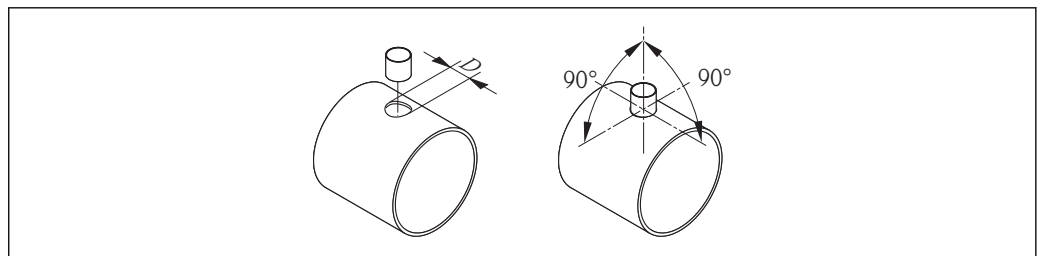

A0011843

$$D = 31.0 \text{ mm} \pm 0.05 \text{ mm} (1.22 \text{ in} \pm 0.02 \text{ in})$$

► When installing in rectangular ducts with thin walls:

- ✓ Use suitable support brackets.

**Align the insertion version with the direction of flow.**

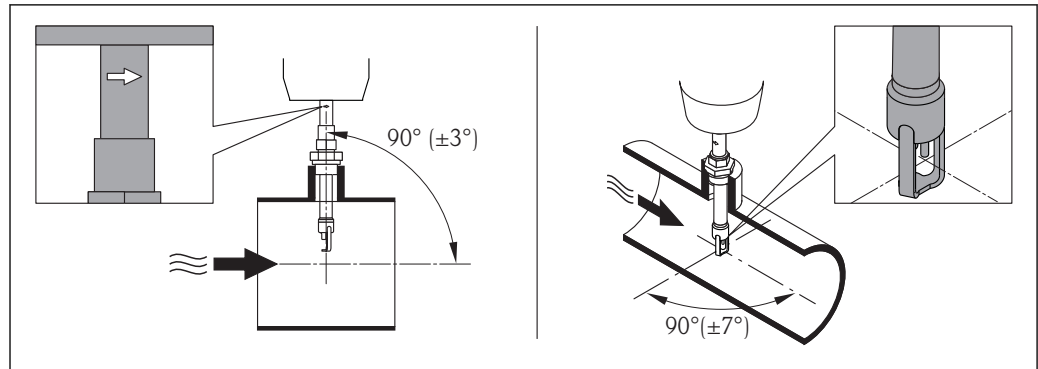

A0015746

Check and ensure that the sensor on the pipe/duct is aligned at a 90° angle to the direction of flow. Rotate the sensor so that the arrow marking on the sensor body corresponds to the direction of flow. The line marking on the body used to adjust the insertion depth must be aligned with the direction of flow.

**Inlet and outlet runs**

The thermal measuring principle is sensitive to disturbed flow conditions.

- As a general rule, the measuring device should always be installed as far away as possible from any flow disturbances. For further information, please refer to → ISO 14511.
- If possible, the sensor should be installed upstream from valves, T-pieces, elbows etc. To attain the specified level of accuracy of the measuring device, the below mentioned inlet and outlet runs must be maintained at minimum. If there are several flow disturbances present, the longest specified inlet run must be maintained.

*Recommended inlet and outlet runs*

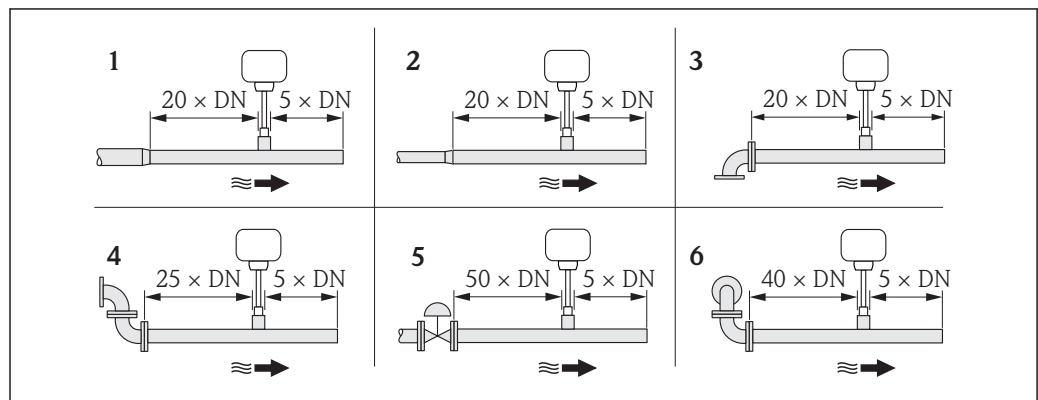

A0016943

- 1 reduction
- 2 expansion
- 3 90° elbow or T-piece
- 4 2 x 90° elbow
- 5 Control valve
- 6 2 x 90° elbow (3-dimensional)

*Installation dimensions*

 For the dimensions and installation lengths of the device, see the "Technical Information" document, "Mechanical construction" section

### Outlet run for pressure or temperature transmitter

If a pressure or temperature measuring device is installed downstream of the measuring device, make sure there is sufficient distance between the two devices.

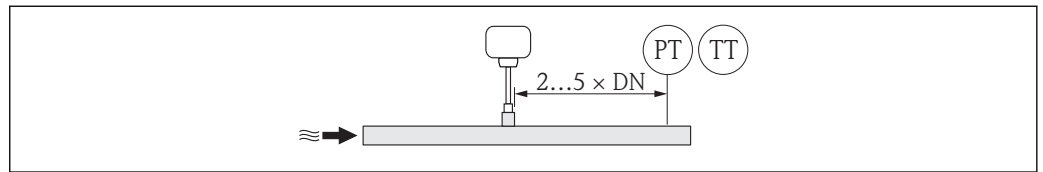

A0015603

PT Pressure measuring device  
TT Temperature measuring device

## 6.1.2 Requirements from environment and process

### Ambient temperature range

Measuring device	-40 to +60 °C (-40 to +140 °F)
Local display	-20 to +60 °C (-4 to +140 °F), the readability of the display may be impaired at temperatures outside the temperature range.

- ▶ If operating outdoors:  
Avoid direct sunlight, particularly in warm climatic regions.

### System pressure

#### Sensor

Depending on the version, please note the details on the name plate .  
Max. 20 bar g (290 psi g)

### Thermal insulation

If the gas is very humid or saturated with water, the pipe and the sensor housing should be insulated to prevent water droplets condensing on the transducer.

#### NOTICE

#### Electronics overheating on account of thermal insulation!

- ▶ Observe maximum permitted insulation height of the transmitter neck so that the transmitter head is completely free.

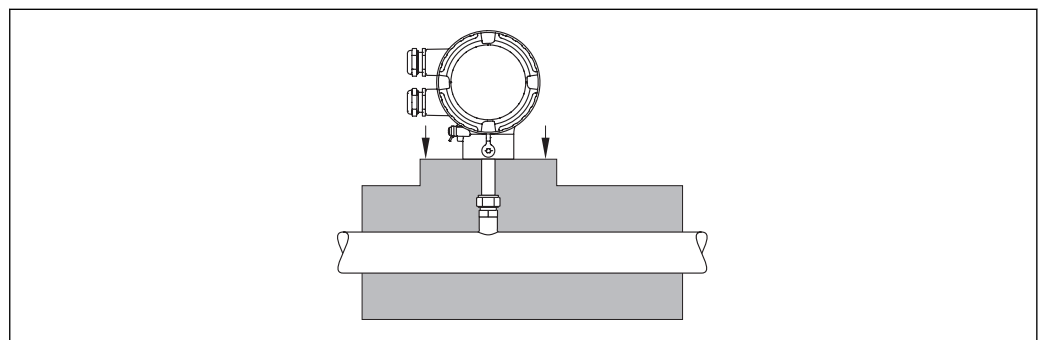

A0015763

## 6.2 Mounting the measuring device

### 6.2.1 Required tools

#### For transmitter

For turning the transmitter housing (in increments of 90°): Allen screw 4 mm (0.15 in)

#### For sensor

For the sensor gland: Corresponding mounting tools

### 6.2.2 Preparing the measuring device

1. Remove all remaining transport packaging.
2. Remove the protective cap from the sensor.
3. Remove stick-on label on the electronics compartment cover.

### 6.2.3 Mounting the measuring device

#### **⚠ WARNING**

#### Danger due to improper process sealing!

- ▶ Ensure that the gaskets are clean and undamaged (G 1 A, G ¾ A).
- ▶ Ensure that the correct sealing material has been used (e.g. Teflon tape for NPT 1", NPT ¾").
- ▶ Install the gaskets correctly.

1. Ensure that the direction of the arrow on the sensor matches the flow direction of the medium.

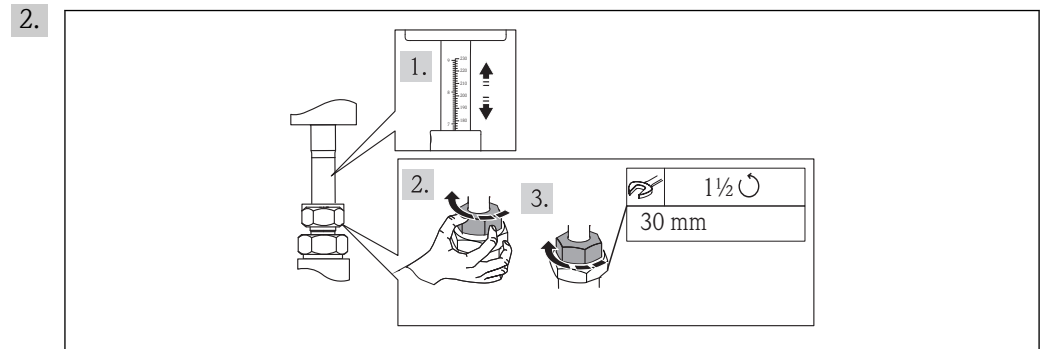

A0017331

Ensure the insertion depth and alignment are correct. Thread adapter nut: when mounting for the first time, tighten it fingertight + 1 ½ turns. For all other mounting routines, tighten it fingertight and 1 additional turn

3. Install the measuring device or turn the transmitter housing so that the cable entries do not point upwards.

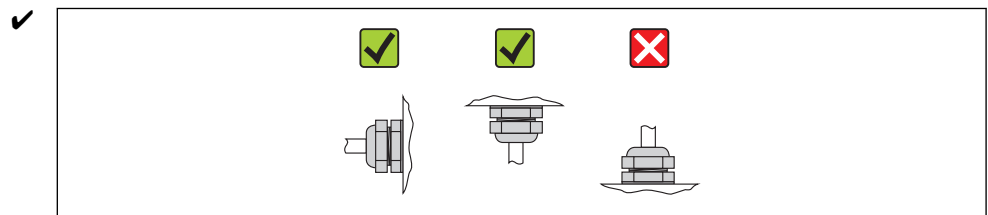

A0013964

### 6.2.4 Turning the transmitter housing

To provide easier access to the connection compartment or display module, the transmitter housing can be turned clockwise or counterclockwise to 4 indexed positions by a maximum of 2 x 90°:

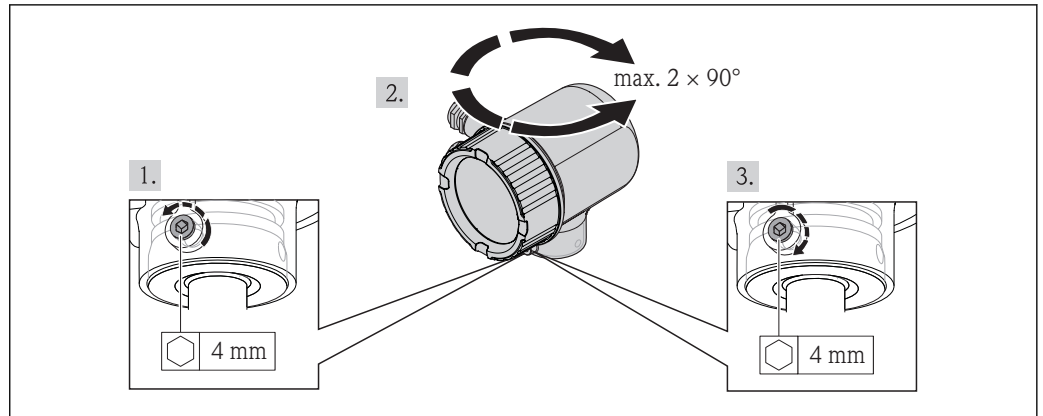

A0017227

1. Unscrew the securing screw using an Allen key.
2. Rotate the housing in the desired direction.
3. Firmly tighten the securing screw.

### 6.2.5 Turning the display module

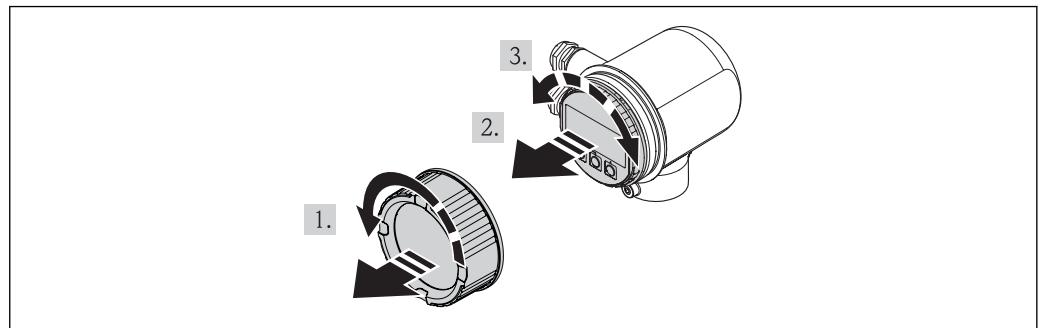

A0017228

1. Remove the cover of the electronics compartment.
2. Pull out the display module with a gentle rotational movement.
3. Turn the display module to the desired position: Max. 4x90° in each direction.
4. Feed the ribbon cable into the gap between the housing and main electronics module and plug the display module into the electronics compartment and turn it until it engages.
5. Screw the cover of the electronics compartment back on.

## 6.3 Post-mounting check

Is the device damaged (visual inspection)?	<input type="checkbox"/>
Does the measuring device conform to the measuring point specifications? For example: <ul style="list-style-type: none"> <li>■ Process temperature (→ 106)</li> <li>■ Process pressure (refer to the chapter on "Material load curves" of the "Technical Information" document)</li> <li>■ Ambient temperature range (→ 19)</li> <li>■ Measuring range (→ 97)</li> </ul>	<input type="checkbox"/>
Has the correct orientation for the sensor been selected (→ 15)? <ul style="list-style-type: none"> <li>■ According to sensor type</li> <li>■ According to medium properties</li> <li>■ According to medium temperature</li> <li>■ According to process pressure</li> </ul>	<input type="checkbox"/>
Does the arrow on the sensor match the direction of flow of the medium through the piping (→ 15)?	<input type="checkbox"/>
Have sufficient inlet and outlet runs been provided upstream and downstream of the measuring point?	<input type="checkbox"/>
Correctly aligned in the direction of flow?	<input type="checkbox"/>
Correct sensor immersion depth?	<input type="checkbox"/>
Is the device adequately protected from precipitation and direct sunlight?	<input type="checkbox"/>
Is the device protected against overheating?	<input type="checkbox"/>
Is the device protected against excessive vibrations?	<input type="checkbox"/>
Check gas property (e.g. purity, dryness, cleanness).	<input type="checkbox"/>
Are the measuring point identification and labeling correct (visual inspection)?	<input type="checkbox"/>

## 7 Electrical connection

### 7.1 Connection conditions

#### 7.1.1 Required tools

- For cable entries: Use corresponding tools
- Wire stripper
- When using stranded cables: Crimping tool for wire end ferrule
- Flat blade screwdriver ≤ 3 mm (0.12 in)

#### 7.1.2 Requirements for connecting cable

The connecting cables provided by the customer must fulfill the following requirements.

##### Electrical safety

In accordance with applicable federal/national regulations.

##### Cable specification

Permitted temperature range:

- $-40\text{ °C}$  ( $-40\text{ °F}$ )... $\geq 80\text{ °C}$  ( $176\text{ °F}$ )
- Minimum requirement for cable temperature range: ambient temperature  $+20\text{ K}$

Current output

For 4-20 mA HART: Shielded cable recommended. Observe grounding concept of the plant.

Pulse/frequency/switching output

Standard installation cable is sufficient

Cable diameter

- Included cable glands: M20 × 1.5 with cable  $\varnothing$  6 to 12 mm (0.24 to 0.47 in)
- Core cross-sectional area 0.5 to 1.5 mm<sup>2</sup> (21 to 16 AWG)

#### 7.1.3 Requirements for the supply unit

##### Device supply voltage

DC 24 V (18 to 30 V)

The power supply circuit must comply with ELV (BS 7671) requirements.

##### Pulse/frequency/status supply voltage

An external power supply is required for each output.

Order characteristic for "Output"	Maximum terminal voltage
Option B, K	DC 30 V

##### Load

0 to 750  $\Omega$ , depending on the external supply voltage of the power supply unit

#### 7.1.4 Terminal assignment

The terminal assignment for the electrical connection can be found on the nameplate of the electronics module.

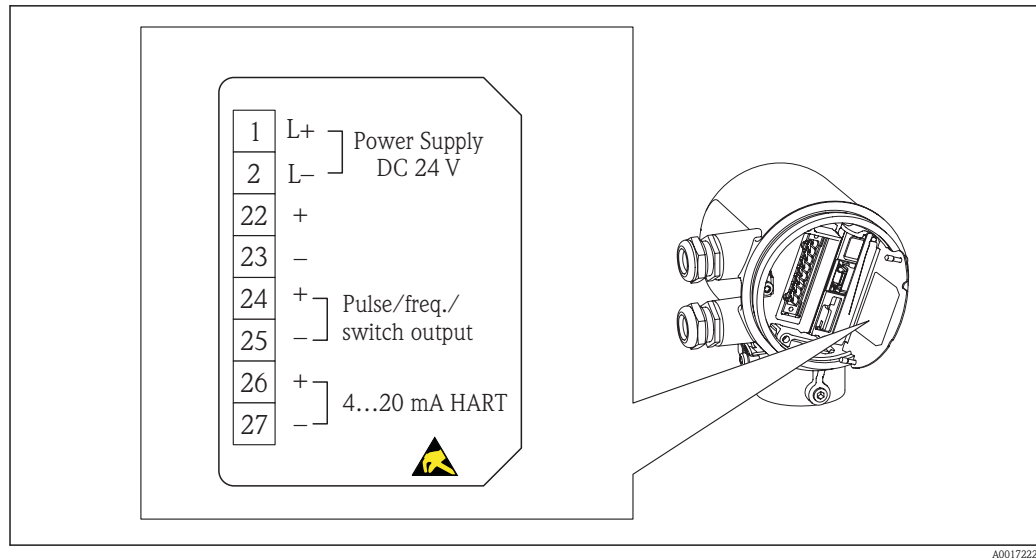

A0017222

### 7.1.5 Preparing the measuring device

1. Remove dummy plug if present.
2. **NOTICE!** Insufficient sealing of the housing. Operational reliability of the measuring device could be defeated. Use suitable cable glands corresponding to the degree of protection.  
If measuring device is delivered without cable glands:  
Provide suitable cable gland for corresponding connecting cable. (→ 23)
3. If measuring device is delivered with cable glands:  
Observe cable specification (→ 23).

## 7.2 Connecting the measuring device

### NOTICE

#### Limitation of electrical safety due to incorrect connection!

- ▶ Have electrical connection work carried out by correspondingly trained specialists only.
- ▶ Observe applicable federal/national installation codes and regulations.
- ▶ Comply with local workplace safety regulations.
- ▶ SELV/PELV-compliant 24 V DC (18 to 30 V) power supply.
- ▶ 4 to 20 mA HART active
- ▶ Maximum output values: DC 24V, 22 mA, load 0 to 750 Ω



### 7.2.1 Connecting the cables

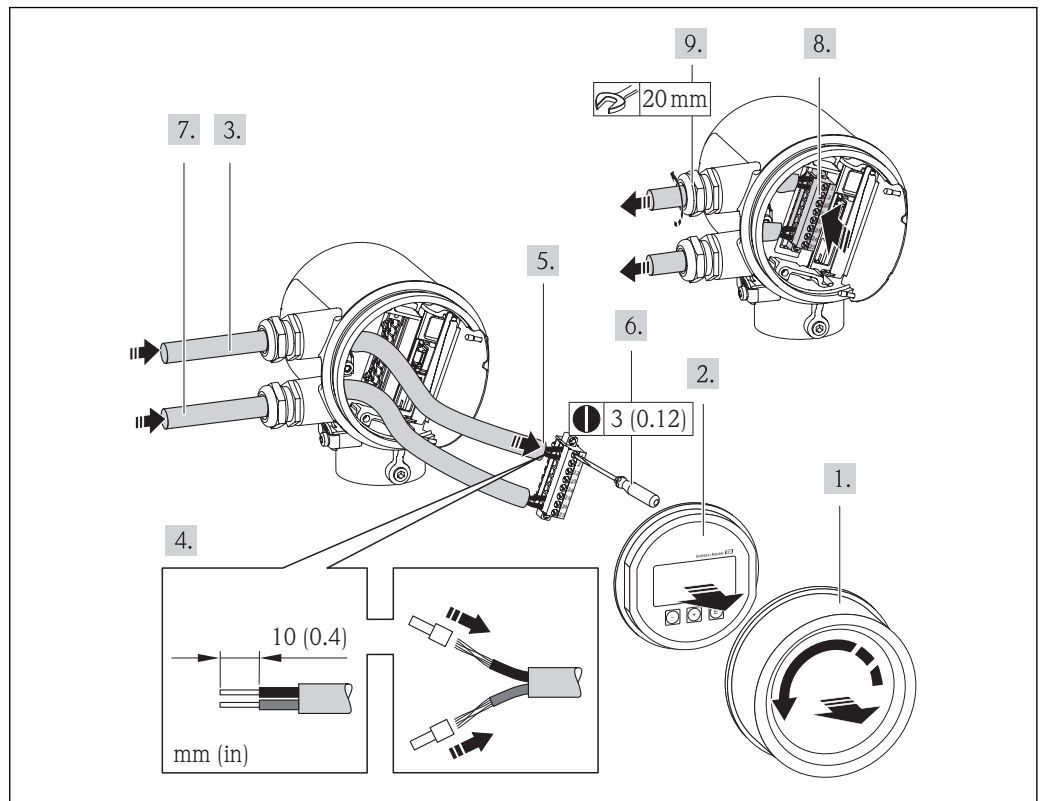

1. Unscrew the connection compartment cover.
2. Remove the display module.
3. Push the supply cable through the cable entry. To ensure tight sealing, do not remove the sealing ring from the cable entry.
4. Strip the cable and cable ends. In the case of stranded cables, also fit wire end ferrules.
5. Connect the cable in accordance with the terminal assignment (→ 102). For HART communication: When connecting the cable shielding to the ground terminal, observe the grounding concept of the facility.
6. Firmly tighten the screws in the terminal block.
7. Perform the same steps for the signal cable as for the power supply cable.
8. Insert the terminal block into the electronics module.
9. Firmly tighten the cable glands.
10. **NOTICE!** Housing degree of protection voided due to insufficient sealing of the housing. Screw in the thread without using any lubricant. The threads on the cover are coated with a dry lubricant.  
Reverse the removal procedure to reassemble the transmitter.

### 7.3 Ensuring the degree of protection

The measuring device fulfills all the requirements for the IP66 and IP67 (Type 4X enclosure) degree of protection.

To guarantee IP 66 and IP 67 degree of protection (Type 4X enclosure), carry out the following steps after the electrical connection:

1. Check whether the housing seals of the connection and electronics compartment are clean and inserted correctly. Dry, clean or replace the seals if necessary.

2. Tighten all housing screws and screw covers.
3. Firmly tighten the cable glands.
4. To ensure that moisture does not enter the cable entry, route the cable so that it loops down before the cable entry ("water trap").

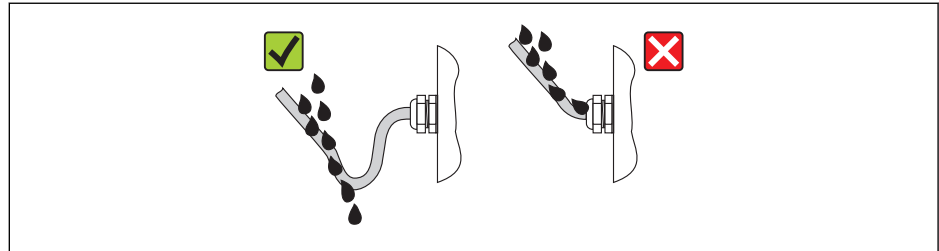

A0013960

5. Insert dummy plugs into unused cable entries.

## 7.4 Post-connection check

Are cables or the device undamaged (visual inspection)?	<input type="checkbox"/>
Are the power supply and signal cables correctly connected?	<input type="checkbox"/>
Does the supply voltage correspond to the specifications in the connection diagram?	<input type="checkbox"/>
Do the cables comply with the requirements (→ 23)?	<input type="checkbox"/>
Do the cables have adequate strain relief? Are they routed securely?	<input type="checkbox"/>
Is the cable route completely isolated? Without loops and cross-overs?	<input type="checkbox"/>
Are all the screw terminals firmly tightened?	<input type="checkbox"/>
Are all the cable glands installed, firmly tightened and leak-tight? Cable run with "water trap" (→ 23) ?	<input type="checkbox"/>
Does the supply voltage match the specifications on the transmitter nameplate (→ 23)?	<input type="checkbox"/>
Is the terminal assignment correct (→ 23)?	<input type="checkbox"/>
If supply voltage is present, is the device ready for operation and do values appear on the display module?	<input type="checkbox"/>
Are all housing covers installed and firmly tightened?	<input type="checkbox"/>

## 8 Operation options

### 8.1 Overview of operation options

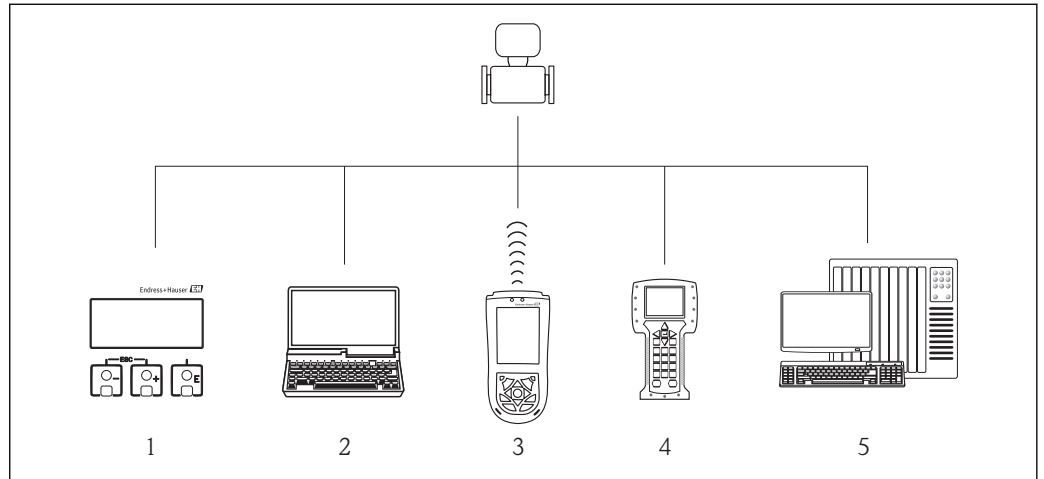

- 1 Local operation via display module
- 2 Computer with operating tool (e.g. FieldCare, AMS Device Manager, SIMATIC PDM)
- 3 Field Xpert SFX100
- 4 Field Communicator 475
- 5 Control system (e.g. PLC)

### 8.2 Structure and function of the operating menu

#### 8.2.1 Structure of the operating menu

 For an overview of the operating menu with menus and parameters (→  112)

 For an overview of the operating menu for experts: (→  112)

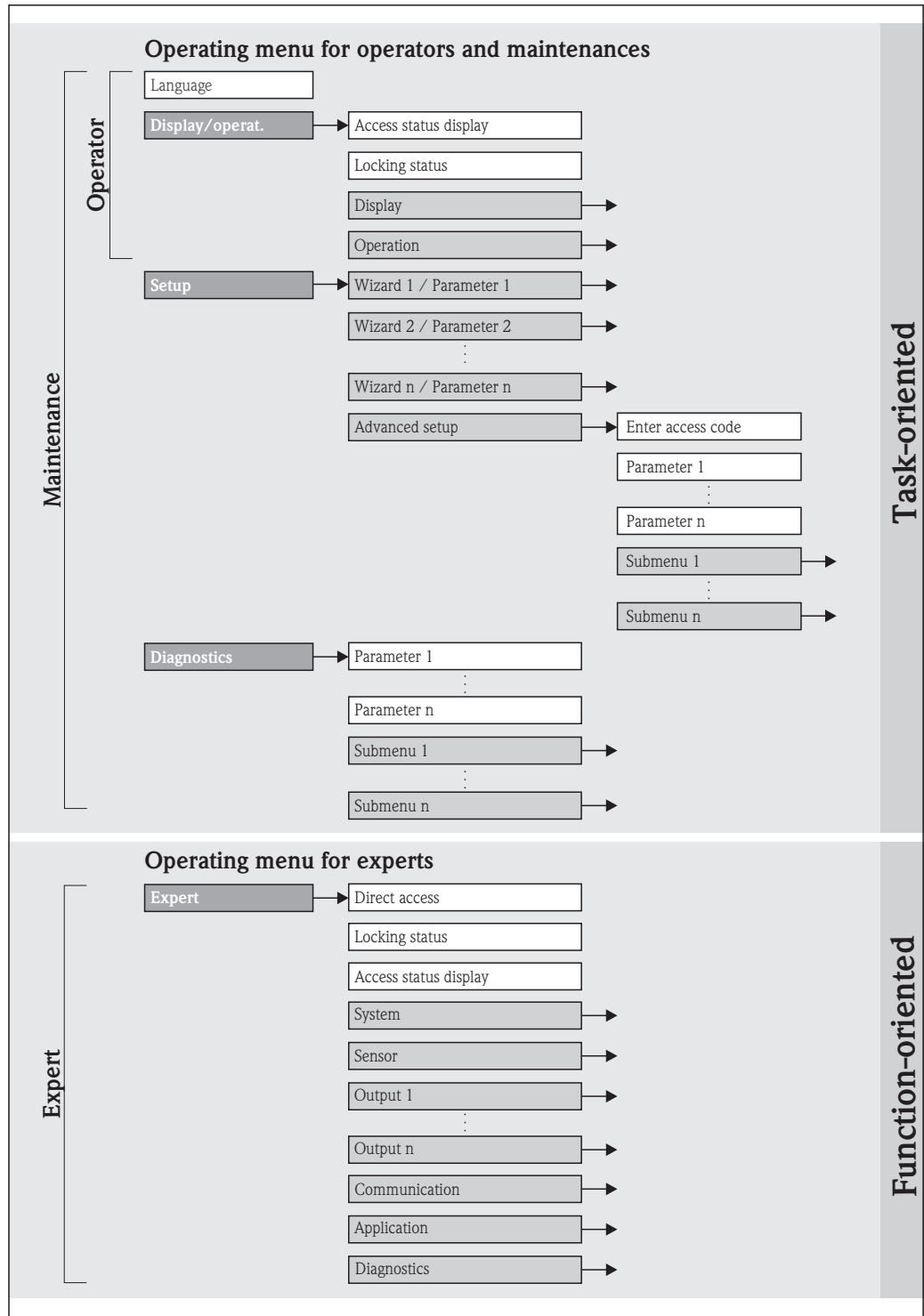

A0018237-EN

### 8.2.2 Operating philosophy

The individual parts of the operating menu are assigned to certain user roles. Each user role contains typical tasks within the device lifecycle.

Menu		User role and tasks	Content/meaning
Language	task-oriented	<b>Role "Operator", "Maintenance"</b> Tasks during operation: <ul style="list-style-type: none"> <li>■ Configuring the measured value display</li> <li>■ Reading measured values</li> </ul>	Defining the operating language
Display/operat.			Configuration of the measured value display (e.g. display format, display contrast) Resetting and controlling totalizers
Setup		<b>"Maintenance" role</b> Commissioning: <ul style="list-style-type: none"> <li>■ Configuration of the measurement</li> <li>■ Configuration of the outputs</li> </ul>	Wizards for quick commissioning: <ul style="list-style-type: none"> <li>■ Defining the medium</li> <li>■ Configuring the outputs</li> <li>■ Configuring the measured value display</li> <li>■ Defining the output conditioning</li> <li>■ Configuring the low flow cut off</li> </ul> "Advanced setup" submenu: <ul style="list-style-type: none"> <li>■ For more customized configuration of the measurement (adaptation to special measuring conditions)</li> <li>■ Configuration of totalizers</li> </ul>
Diagnosis		<b>"Maintenance" role</b> Fault elimination: <ul style="list-style-type: none"> <li>■ Diagnostics and elimination of process and device errors</li> <li>■ Measured value simulation</li> </ul>	Contains all parameters for error detection and analyzing process and device errors: <ul style="list-style-type: none"> <li>■ <b>"Diagnostic list" submenu</b> Contains up to 5 currently pending diagnostic messages.</li> <li>■ <b>"Event logbook" submenu</b> Contains up to 20 or 100 (order option) event messages that have occurred.</li> <li>■ <b>"Device information" submenu</b> Contains information for identifying the device.</li> <li>■ <b>"Measured values" submenu</b> Contains all current measured values.</li> <li>■ <b>"Data logging" submenu (order option)</b> Storage and visualization of up to 1000 measured values</li> <li>■ <b>"Simulation" submenu</b> Is used to simulate measured values or output values.</li> <li>■ <b>"Device reset" submenu</b> Resets the device configuration to certain settings</li> </ul>
Expert	function-oriented	Tasks that require detailed knowledge of the function of the device: <ul style="list-style-type: none"> <li>■ Commissioning measurements under difficult conditions</li> <li>■ Optimal adaptation of the measurement to difficult conditions</li> <li>■ Detailed configuration of the communication interface</li> <li>■ Error diagnostics in difficult cases</li> </ul>	Contains all the parameters of the device and makes it possible to access these parameters directly using an access code. The structure of this menu is based on the function blocks of the device: <ul style="list-style-type: none"> <li>■ <b>"System" submenu</b> Contains all higher-order device parameters that do not pertain either to measurement or the measured value communication.</li> <li>■ <b>"Sensor" submenu</b> Contains all parameters for configuring the measurement.</li> <li>■ <b>"Output" submenu</b> Contains all parameters for configuring the analog current outputs.</li> <li>■ <b>"Communication" submenu</b> Contains all parameters for configuring the digital communication interface.</li> <li>■ <b>"Application" submenu</b> Contains all parameters for configuring the functions that go beyond the actual measurement (e.g. totalizer).</li> <li>■ <b>"Diagnostics" submenu</b> Contains all parameters for error detection and analyzing process and device errors and for device simulation.</li> </ul>

## 8.3 Access to the operating menu via the local display

### 8.3.1 Operational display

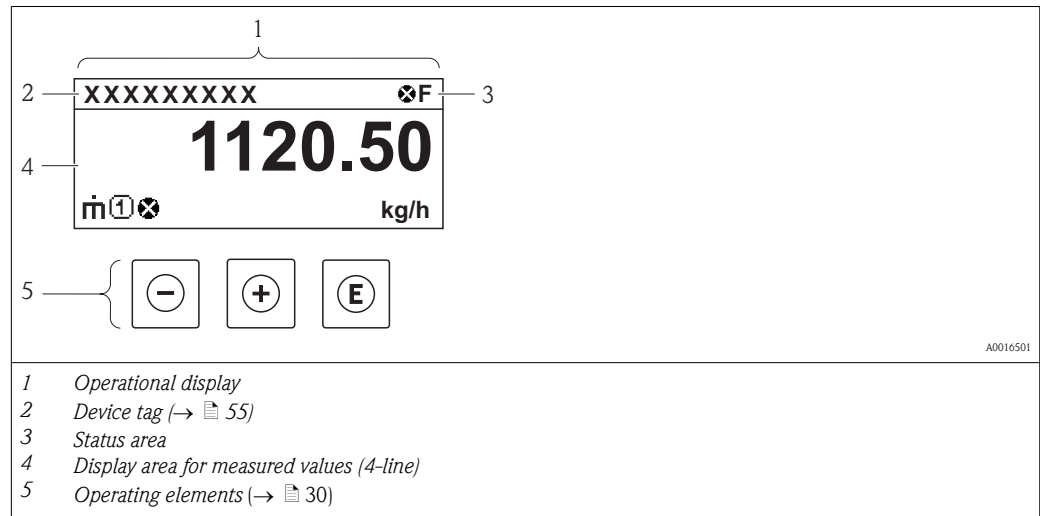

#### Status area

The following symbols appear in the status area of the operational display at the top right:

#### Status signals

Symbol	Meaning
<b>F</b> <small>A0013956</small>	<b>Failure</b> A device error has occurred. The measured value is no longer valid.
<b>C</b> <small>A0013959</small>	<b>Function check</b> The device is in service mode (e.g. during a simulation).
<b>S</b> <small>A0013958</small>	<b>Out of specification</b> The device is being operated: <ul style="list-style-type: none"> <li>■ Outside its technical specification limits (e.g. outside the process temperature range)</li> <li>■ Outside of the configuration carried out by the user (e.g. maximum flow in parameter <b>20 mA value</b>)</li> </ul>
<b>M</b> <small>A0013957</small>	<b>Maintenance required</b> Maintenance is required. The measured value is still valid.

#### Diagnostic behavior

Symbol	Meaning
 <small>A0013961</small>	<b>Alarm</b> Measurement is interrupted. The signal outputs and totalizers assume the defined alarm condition. A diagnostics message is generated (→ 84).
 <small>A0013962</small>	<b>Warning</b> Measurement is resumed. The signal outputs and totalizers are not affected. A diagnostics message is generated (→ 84).

#### Locking



Symbol	Meaning
 <small>A0013963</small>	<b>Device locked</b> The measuring device is hardware locked (→ 73).

*Communication*





Symbol	Meaning
 <small>A0013965</small>	Communication via remote operation is active.

**Display area**

In the display area, each measured value is prefaced by certain symbol types for further description:

	Measured variable	Measurement channel number	Diagnostic behavior
	↓	↓	↓
Example	 <small>A0013945</small>	 <small>A0013948</small>	 <small>A0013962</small>
			Appears only if a diagnostics event is present for this measured variable.

*Measured variables*

Symbol	Meaning
 <small>A0013711</small>	Corrected volume flow, FAD
 <small>A0013710</small>	Mass flow
 <small>A0013947</small>	Temperature
 <small>A0013943</small>	Totalizer
 <small>A0013945</small>	Current output

*Measurement channel numbers*

Symbol	Meaning
 <small>A0016325</small>	Measurement channel 1 to 4
The measurement channel number is displayed only if more than one channel is present for the same measured variable type.	

*Diagnostic behavior*

The diagnostic behavior pertains to a diagnostic event that is relevant to the displayed measured variable. For more information about the symbols, refer to the "Status area" section (→ 30).

 The number and display of the measured values can be configured via the parameter **Format display**.

**Navigation path**

"Display/operat." menu → Display → Format display

### 8.3.2 Navigation view

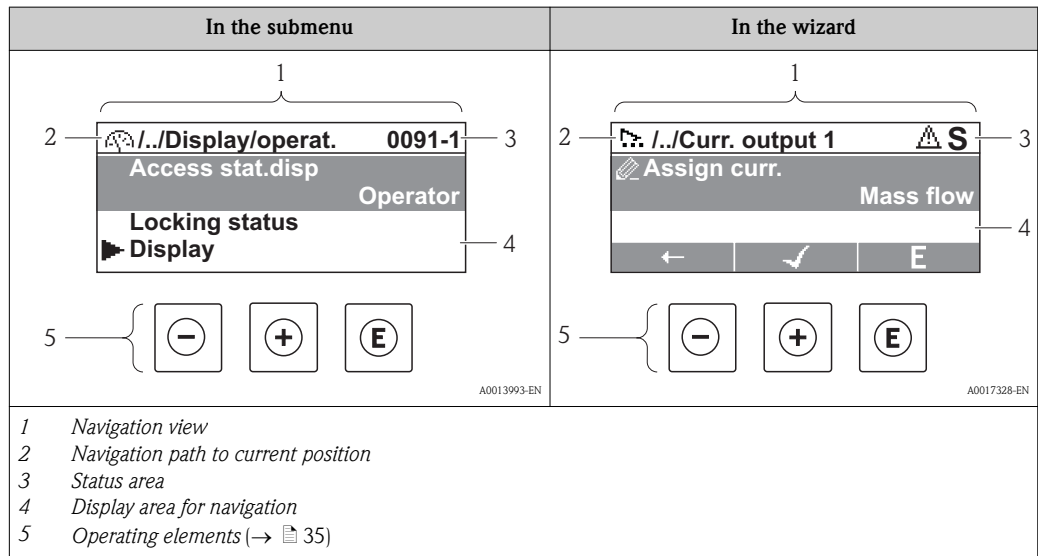

#### Navigation path

The navigation path - displayed at the top left in the navigation view - consists of the following elements:

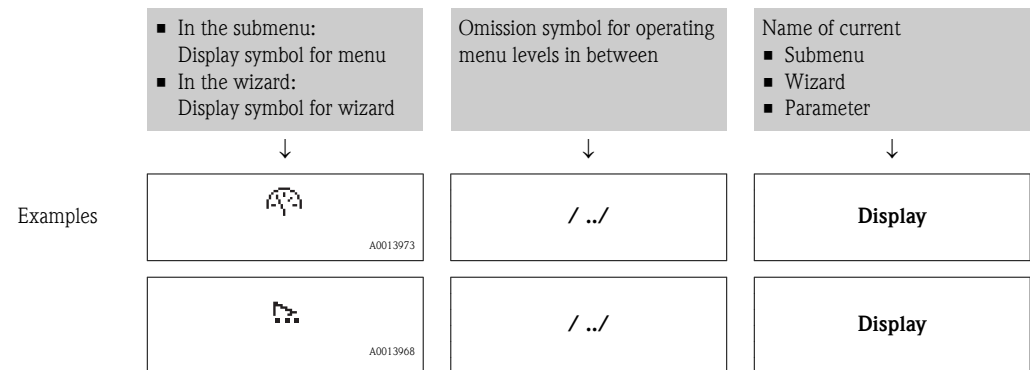

For more information about the menu icons, refer to the "Display area" section (→ 33)

#### Status area

The following appears in the status area of the navigation view in the top right corner:

- Of the submenu
  - The direct access code for the parameter you are navigating to (e.g. 0022-1)
  - If a diagnostic event is present, the diagnostic behavior and status signal
- In the wizard
  - If a diagnostic event is present, the diagnostic behavior and status signal





For information on the diagnostic behavior and status signal (→ 84)

For information on entering the direct access code and how this function works: (→ 38)







## Display area



### Menus

Symbol	Meaning
 A0013973	<b>Display/operat.</b> Appears: <ul style="list-style-type: none"> <li>■ In the menu next to the "Display/operat." selection</li> <li>■ At the left in the navigation path in the "Display/operat." menu</li> </ul>
 A0013974	<b>Setup</b> Appears: <ul style="list-style-type: none"> <li>■ In the menu next to the "Setup" selection</li> <li>■ At the left in the navigation path in the "Setup" menu</li> </ul>
 A0013975	<b>Diagnosis</b> Appears: <ul style="list-style-type: none"> <li>■ In the menu next to the "Diagnostics" selection</li> <li>■ At the left in the navigation path in the "Diagnostics" menu</li> </ul>
 A0013966	<b>Expert</b> Appears: <ul style="list-style-type: none"> <li>■ In the menu next to the "Expert" selection</li> <li>■ At the left in the navigation path in the "Expert" menu</li> </ul>



### Submenus, wizards, parameters

Symbol	Meaning
 A0013967	Submenu
 A0013968	Wizard
 A0013972	Parameters within a wizard  No display symbol exists for parameters in submenus.

### Locking

Symbol	Meaning
 A0013963	<b>Parameter locked</b> When displayed in front of a parameter name, indicates that the parameter is locked. <ul style="list-style-type: none"> <li>■ By a user-specific access code (→  74)</li> <li>■ By the hardware write protection switch (→  73)</li> </ul>

### Wizard operation

Symbol	Meaning
 A0013978	Switches to the previous parameter.
 A0013976	Confirms the parameter value and switches to the next parameter.
 A0013977	Opens the editing view of the parameter.

### 8.3.3 Editing view

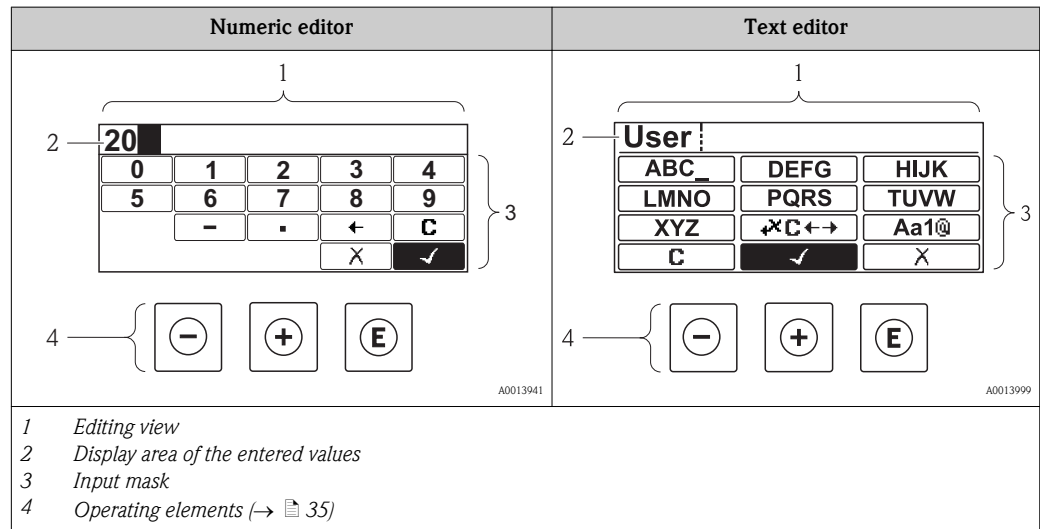

#### Input mask





The following input symbols are available in the input mask of the numeric and text editor:

##### Numeric editor





Symbol	Meaning
<p>A0013998</p>	Selection of numbers from 0 to 9.
<p>A0016619</p>	Inserts decimal separator at the input position.
<p>A0016620</p>	Inserts minus sign at the input position.
<p>A0013985</p>	Confirms selection.
<p>A0016621</p>	Moves the input position one position to the left.
<p>A0013986</p>	Exits the input without applying the changes.
<p>A0014040</p>	Clears all entered characters.

##### Text editor



Symbol	Meaning
<p>A0013997</p>	Selection of letters from A to Z
<p>A0013981</p>	Toggle <ul style="list-style-type: none"> <li>▪ Between upper-case and lower-case letters</li> <li>▪ For entering numbers</li> <li>▪ For entering special characters</li> </ul>





 <small>A0013985</small>	Confirms selection.
 <small>A0013987</small>	Switches to the selection of the correction tools.
 <small>A0013986</small>	Exits the input without applying the changes.
 <small>A0014040</small>	Clears all entered characters.

*Correction symbols under *

Symbol	Meaning
 <small>A0013989</small>	Clears all entered characters.
 <small>A0013991</small>	Moves the input position one position to the right.
 <small>A0013990</small>	Moves the input position one position to the left.
 <small>A0013988</small>	Deletes one character immediately to the left of the input position.

### 8.3.4 Operating elements

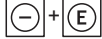
Key	Meaning
 <small>A0013969</small>	<p><b>Minus key</b></p> <p><i>In a menu, submenu</i>                      Moves the selection bar upwards in a choose list.</p> <p><i>With a Wizard</i>                      Confirms the parameter value and goes to the previous parameter.</p> <p><i>With a text and numeric editor</i>                      In the input mask, moves the selection bar to the left (backwards).</p>
 <small>A0013970</small>	<p><b>Plus key</b></p> <p><i>In a menu, submenu</i>                      Moves the selection bar downwards in a choose list.</p> <p><i>With a Wizard</i>                      Confirms the parameter value and goes to the next parameter.</p> <p><i>With a text and numeric editor</i>                      Moves the selection bar to the right (forwards) in an input screen.</p>

Key	Meaning
 <small>A0013952</small>	<p><b>Enter key</b></p> <p><i>For operational display</i></p> <ul style="list-style-type: none"> <li>Pressing the key briefly opens the operating menu.</li> <li>Pressing the key for 2 s opens the context menu.</li> </ul> <p><i>In a menu, submenu</i></p> <ul style="list-style-type: none"> <li>Pressing the key briefly:                             <ul style="list-style-type: none"> <li>Opens the selected menu, submenu or parameter.</li> <li>Starts the wizard.</li> <li>If help text is open, closes the help text of the parameter.</li> </ul> </li> <li>Pressing the key for 2 s for parameter:                             <ul style="list-style-type: none"> <li>If present, opens the help text for the function of the parameter.</li> </ul> </li> </ul> <p><i>With a Wizard</i></p> <p>Opens the editing view of the parameter.</p> <p><i>With a text and numeric editor</i></p> <ul style="list-style-type: none"> <li>Pressing the key briefly:                             <ul style="list-style-type: none"> <li>Opens the selected group.</li> <li>Carries out the selected action.</li> </ul> </li> <li>Pressing the key for 2 s confirms the edited parameter value.</li> </ul>
 <small>A0013971</small>	<p><b>Escape key combination (press keys simultaneously)</b></p> <p><i>In a menu, submenu</i></p> <ul style="list-style-type: none"> <li>Pressing the key briefly:                             <ul style="list-style-type: none"> <li>Exits the current menu level and takes you to the next higher level.</li> <li>If help text is open, closes the help text of the parameter.</li> </ul> </li> <li>Pressing the key for 2 s returns you to the operational display ("home position").</li> </ul> <p><i>With a Wizard</i></p> <p>Exits the wizard and takes you to the next higher level.</p> <p><i>With a text and numeric editor</i></p> <p>Closes the text or numeric editor without applying changes.</p>
 <small>A0013953</small>	<p><b>Minus/Enter key combination (press the keys simultaneously)</b></p> <p>Reduces the contrast (brighter setting).</p>
 <small>A0013954</small>	<p><b>Plus/Enter key combination (press and hold down the keys simultaneously)</b></p> <p>Increases the contrast (darker setting).</p>
 <small>A0013955</small>	<p><b>Minus/Plus/Enter key combination (press the keys simultaneously)</b></p> <p><i>For operational display</i></p> <p>Enables or disables the keypad lock.</p>

### 8.3.5 Opening the context menu

Using the context menu, the user can call up the following three menus quickly and directly from the measured value display:

- Setup
- Conf. backup disp.
- Simulation

#### Calling up and closing the context menu

The user is in the measured value display.

1. Press  for 2 s.
  - ✓ The context menu opens.

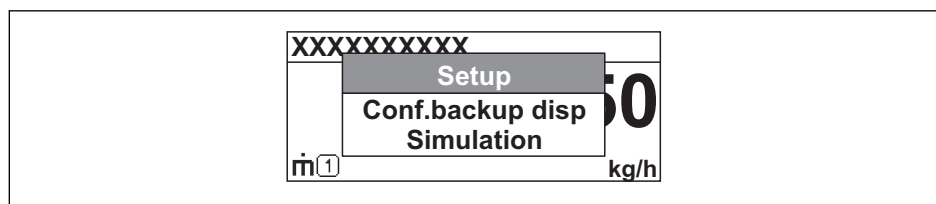

A0014003-EN



2. Press  $\square$  +  $\square$  simultaneously.
  - ✓ The context menu is closed and the measured value display appears.

#### **Calling up the menu via the context menu**

1. Open the context menu.
2. Press  $\square$  to navigate to the desired menu.
3. Press  $\square$  to confirm the selection.
  - ✓ The selected menu opens.

### 8.3.6 Navigating and selecting from list

Different operating elements are used to navigate through the operating menu. The navigation path is displayed on the left in the header. Icons are displayed in front of the individual menus. These icons are also shown in the header during navigation.

 For an explanation of the navigation view with symbols and operating elements (→  32)

**Example: Setting the number of displayed measured values to "2 values"**

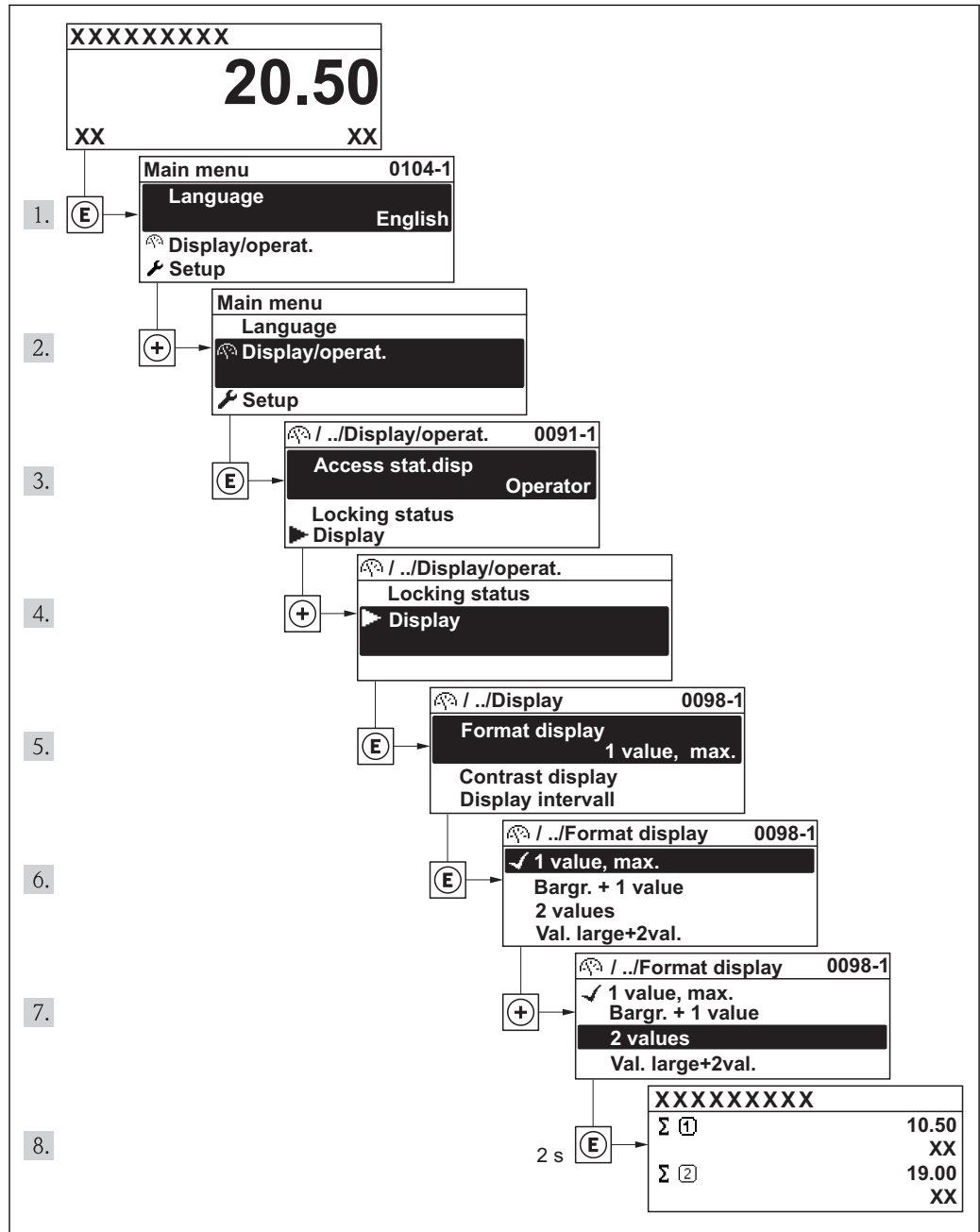

A0014010-EN

### 8.3.7 Calling the parameter directly

A parameter number is assigned to every parameter to be able to access a parameter directly via the onsite display. Entering this access code in the **Direct access** parameter calls up the desired parameter directly.

### Navigation path

"Expert" menu → Direct access

The direct access code consists of a 4-digit number and the channel number, which identifies the channel of a process variable: e.g. 0914-1. In the navigation view, this appears on the right-hand side in the header of the selected parameter.

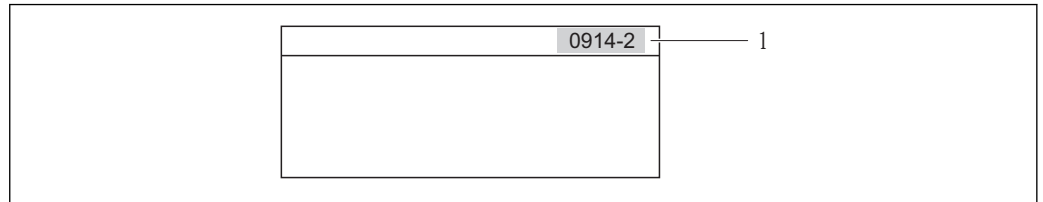

A0017223

1 Direct access code

Note the following when entering the direct access code:

- The leading zeros in the direct access code do not have to be entered.  
Example: Input of "914" instead of "0914"
- If no channel number is entered, channel 1 is jumped to automatically.  
Example: Input of "0914" → Parameter **Totalizer 1**
- If a different channel is jumped to: Enter the direct access code with the corresponding channel number.  
Example: Input of "0914-2" → Parameter **Totalizer 2**



For the direct access codes of the individual parameters (→ 112)(→ 112)

### 8.3.8 Calling up help text

Help text is available for some parameters and can be called up from the navigation view. The help text provides a brief explanation of the parameter function and thereby supports swift and safe commissioning.

#### Calling up and closing the help text

The user is in the navigation view and the selection bar is on a parameter.

1. Press for 2 s.
  - ✓ The help text for the selected parameter opens.

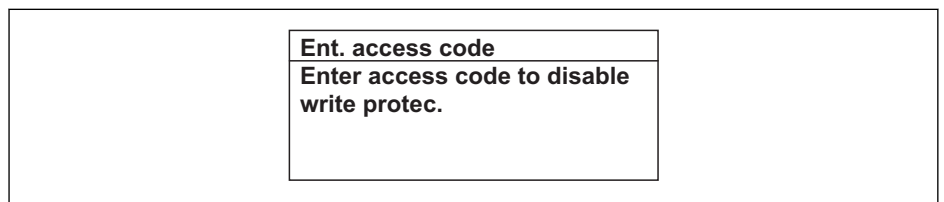

A0014002-EN

3 Example: Help text for parameter "Enter access code"

2. Press + simultaneously.
  - ✓ The help text is closed.

### 8.3.9 Changing the parameters

**i** For a description of the editing display - consisting of text editor and numeric editor - with symbols (→ 34), for a description of the operating elements (→ 30)

**Example: Changing the parameter "20 mA value" to 20 kg/s**

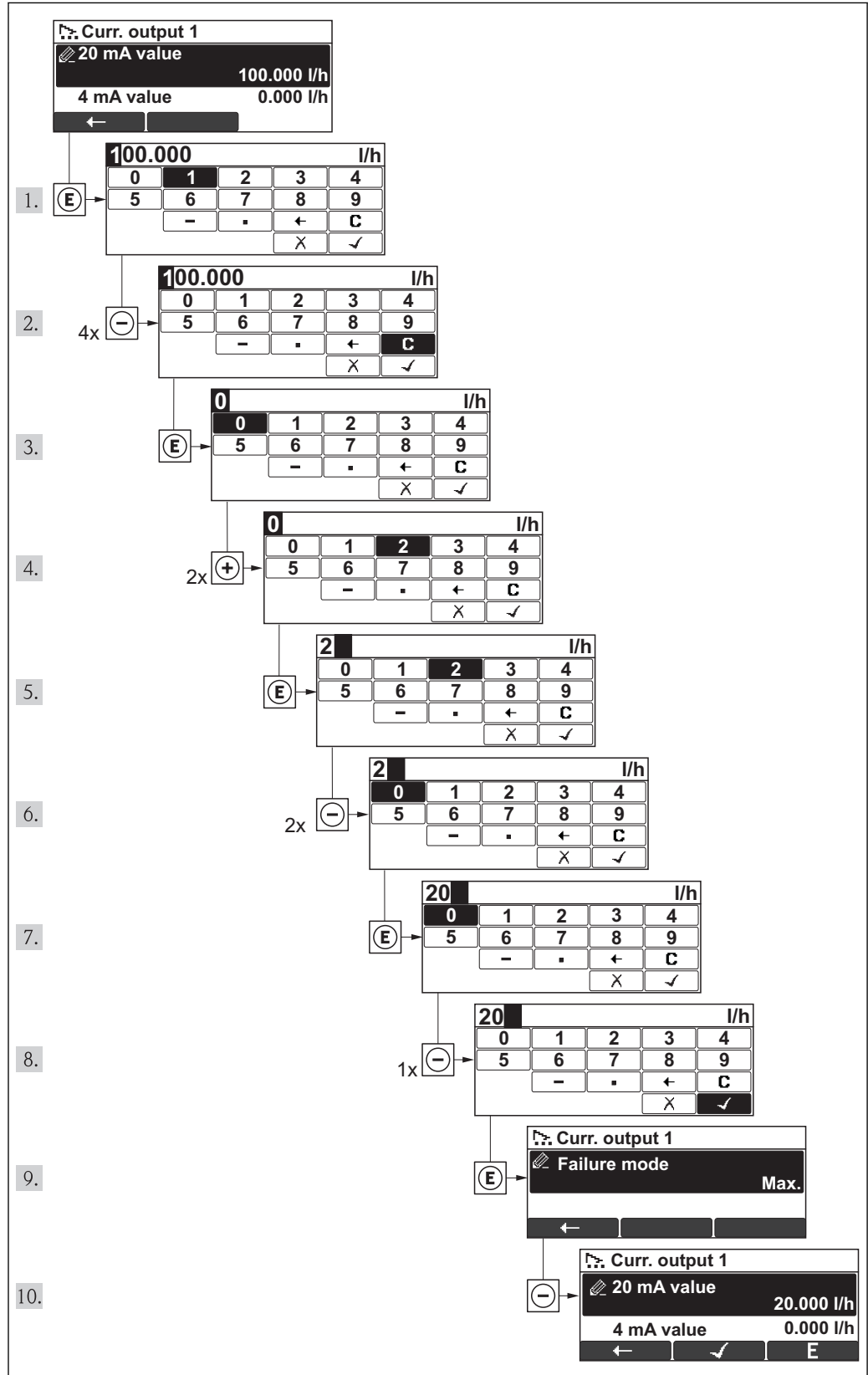

A0016332-EN



A message is displayed if the value entered is outside the permitted value range.

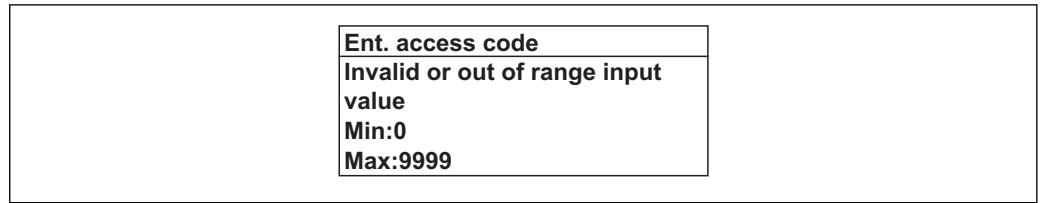

A0014049-EN

### 8.3.10 User roles and related access authorization

The two user roles "Operator" and "Maintenance" have different write access to the parameters if the customer defines a user-specific access code. This protects the device configuration via the local display from unauthorized access (→ 73).

#### Access authorization to parameters

User role	Read access		Write access	
	Without access code (from the factory)	With access code	Without access code (from the factory)	With access code
Operator	✓	✓	✓	– 1)
Maintenance	✓	✓	✓	✓

1) Despite the defined access code, certain parameters can always be modified and thus are excepted from the write protection, as they do not affect the measurement. Refer to the "Write protection via access code" section

If an incorrect access code is entered, the user obtains the access rights of the "Operator" role.

The user role with which the user is currently logged on is indicated by the **Access status display** parameter. Navigation path: Display/operation → Access status display

### 8.3.11 Disabling write protection via access code

If the -symbol appears on the local display in front of a parameter, the parameter is write-protected by a user-specific access code and its value cannot be changed at the moment using the local display(→ 73).

The locking of the write access via local operation can be disabled by entering the customer-defined access code via the respective access option.

1. After you press , the input prompt for the access code appears.
2. Enter the access code.
  - ✓ The -symbol in front of the parameters disappears; all previously write-protected parameters are now re-enabled.

### 8.3.12 Enabling and disabling the keypad lock

The keypad lock makes it possible to block access to the entire operating menu via local operation. As a result, it is no longer possible to navigate through the operating menu or change the values of individual parameters. Users can only read the measured values on the operational display.

The keypad lock is enabled and disabled in the same way:

The user is in the operational display.

- ▶ By simultaneously pressing the + + keys.

✓ After enabling the keypad lock:

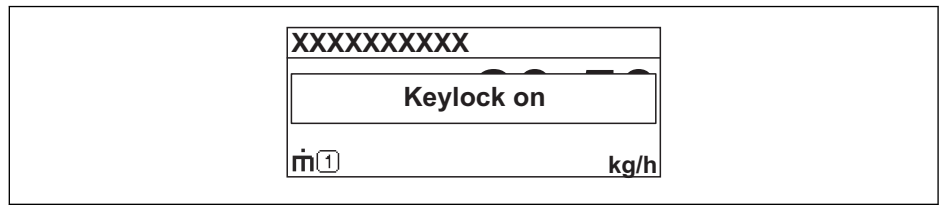

A0014000-EN

After disabling the keypad lock:

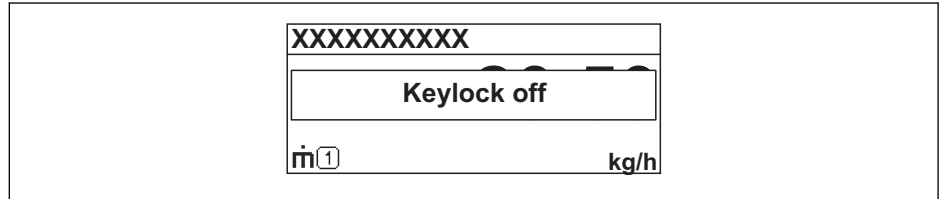

A0014001-EN

**i** If the user attempts to access the operating menu while the keylock is enabled, the message "Keylock on" also appears.

## 8.4 Access to the operating menu via the operating tool

The structure of the operating menu in the operating tools is the same as for operation via the local display.

### 8.4.1 Field Xpert SFX100

#### Function range

Compact, flexible and robust industrial handheld terminal for remote configuration and measured value display via HART protocol.

 For details, see Operating Instructions BA00060S

#### Source for device description files

See data (→  46)

### 8.4.2 FieldCare

#### Function range

FDT-based plant asset management tool from Endress+Hauser. It can configure all smart field devices in a system and helps you manage them. By using the status information, it is also a simple but effective way of checking their status and condition.

Access takes place via:

- HART protocol
- Service interface

Typical functions:

- Configuring parameters of transmitters
- Loading and saving device data (upload/download)
- Documentation of the measuring point
- Visualization of the measured value memory (line recorder) and event logbook

 For details, see Operating Instructions BA00027S and BA00059S

#### Source for device description files

See data (→  46)

#### User interface

### 8.4.3 AMS Device Manager

#### Function range

Program from Emerson Process Management for operating and configuring measuring devices via HART protocol.

#### Source for device description files

See data (→  46)

## 8.4.4 SIMATIC PDM

### Function range

SIMATIC PDM is a standardized, manufacturer-independent program from Siemens for the operation, configuration, maintenance and diagnosis of intelligent field devices via HART protocol.

### Source for device description files

See data (→  46)

## 8.4.5 Field Communicator 475

### Function scope

Industrial handheld terminal from Emerson Process Management for remote configuration and measured value display via HART protocol.

### Source for device description files

See data (→  46)

## 8.4.6 Connecting operating tools

### Via HART protocol

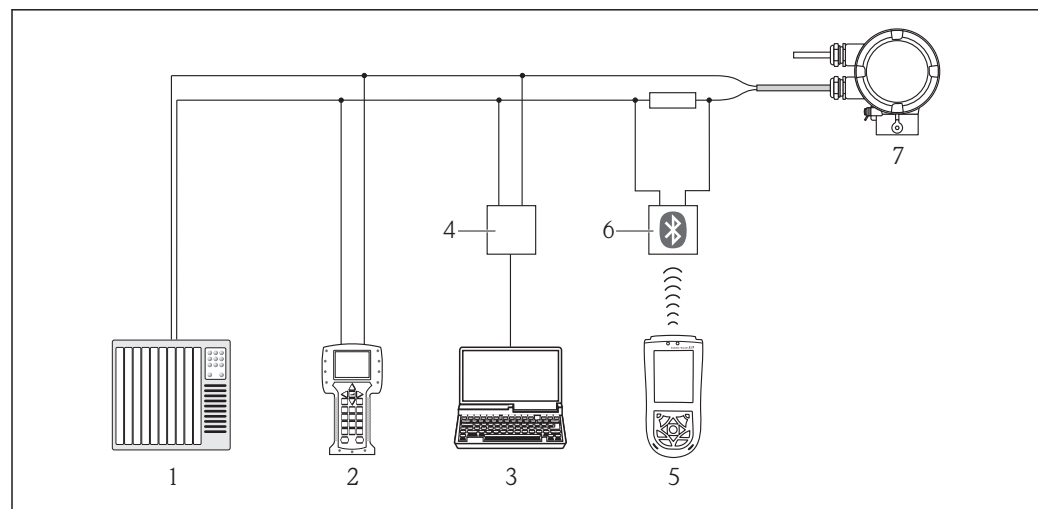

A0017373

- 1 Control system (e.g. PLC)
- 2 Field Communicator 475
- 3 Computer with operating tool (e.g. FieldCare, AMS Device Manager, SIMATIC PDM)
- 4 Commubox FXA195 (USB)
- 5 Field Xpert SFX100
- 6 VIATOR Bluetooth modem with connecting cable
- 7 Transmitter

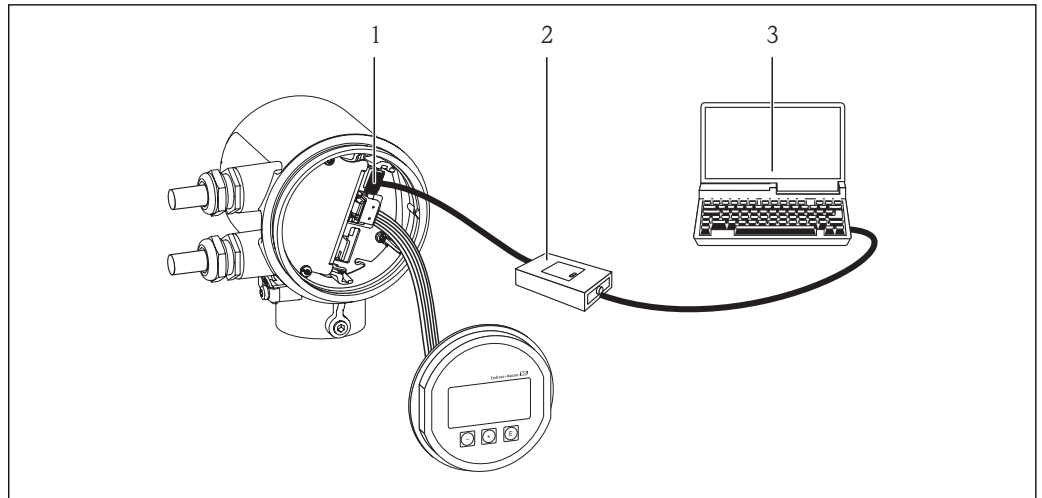
**Via service interface (CDI)**

A0017253

- 1 Service interface (CDI) of the measuring device (= Endress+Hauser Common Data Interface)
- 2 Commubox FXA291
- 3 Computer with "FieldCare" operating tool

## 9 System integration

### 9.1 Overview of device description files

#### 9.1.1 Current version data for the device

Firmware version	01.00.zz	<ul style="list-style-type: none"> <li>■ On the title page of the Operating instructions</li> <li>■ On transmitter nameplate(→ 12)</li> <li>■ Parameter <b>firmware version</b> Diagnostics → Device info → Firmware version</li> </ul>
Release date of firmware version	04.2012	—
Manufacturer ID	0x11	<b>Manufacturer ID</b> parameter Diagnostics → Device info → Manufacturer ID
Device type ID	0x66	<b>Device type</b> parameter Diagnostics → Device info → Device type
HART protocol revision	6.0	—
Device revision	1	<ul style="list-style-type: none"> <li>■ On transmitter nameplate(→ 12)</li> <li>■ <b>Device revision</b> parameter Diagnostics → Device info → Device revision</li> </ul>

#### 9.1.2 Operating tools

The suitable device description file for the individual operating tools is listed in the table below, along with information on where the file can be acquired.

Operating tool via HART protocol	Sources for obtaining device descriptions
Field Xpert SFX100	Use update function of handheld terminal
FieldCare	<ul style="list-style-type: none"> <li>■ <a href="http://www.endress.com">www.endress.com</a> → Download Area</li> <li>■ CD-ROM (contact Endress+Hauser)</li> <li>■ DVD (contact Endress+Hauser)</li> </ul>
AMS Device Manager (Emerson Process Management)	<a href="http://www.endress.com">www.endress.com</a> → Download Area
SIMATIC PDM (Siemens)	<a href="http://www.endress.com">www.endress.com</a> → Download Area
Field Communicator 375, 475 (Emerson Process Management)	Use update function of handheld terminal

### 9.2 Measured variables via HART protocol

The following measured variables (HART device variables) are assigned to the dynamic variables at the factory:

Dynamic variables	Measured variables (HART device variables)
Primary dynamic variable (PV)	Mass flow
Secondary dynamic variable (SV)	Totalizer
Tertiary dynamic variable (TV)	Temperature
Quaternary dynamic variable (QV)	Totalizer

The assignment of the measured variables to the dynamic variables can be modified and assigned as desired via local operation and the operating tool using the following parameters:

- Expert → Communication → HART output → Output → Assign PV
- Expert → Communication → HART output → Output → Assign SV
- Expert → Communication → HART output → Output → Assign TV
- Expert → Communication → HART output → Output → Assign QV

The following measured variables can be assigned to the dynamic variables:

**Measured variables for PV (primary dynamic variable)**

- Mass flow
- Corrected volume flow
- FAD volume flow
- Temperature

**Measured variables for SV, TV, QV (secondary, tertiary and quaternary dynamic variable)**

- None
- Mass flow
- Corrected volume flow
- FAD volume flow
- Temperature
- Totalizer

### 9.3 Other settings

In the **Configuration** submenu, you can configure other settings for the HART protocol (e.g. Burst mode)

**Navigation path**

"Expert" menu → Communication → HART output → Configuration

## 10 Commissioning

### 10.1 Function check

Before commissioning the device, make sure that the post-installation and post-connection checks have been performed.

- "Post-mounting check" checklist (→ [82](#))
- "Post-connection check" checklist (→ [82](#))

### 10.2 Switching on the measuring device

After a successful function check, switch on the measuring device.

After a successful startup, the local display switches automatically from the startup display to the measured value display.

- i** If nothing appears on the local display or a diagnostic message is displayed, refer to the section on "Diagnostics and troubleshooting" (→ [82](#)).

### 10.3 Setting the operating language

Factory setting: English or ordered local language

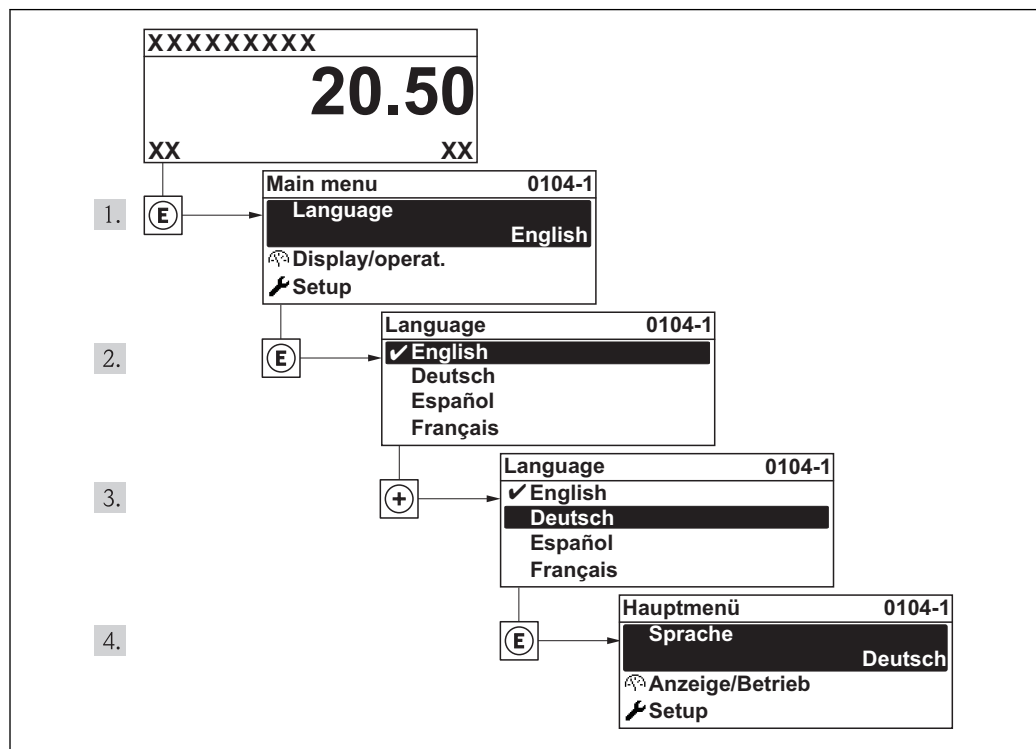



## 10.4 Configuring the measuring device

The **Setup** menu with its guided wizards contains all parameters needed for standard operation.

*Navigation to the "Setup" menu*

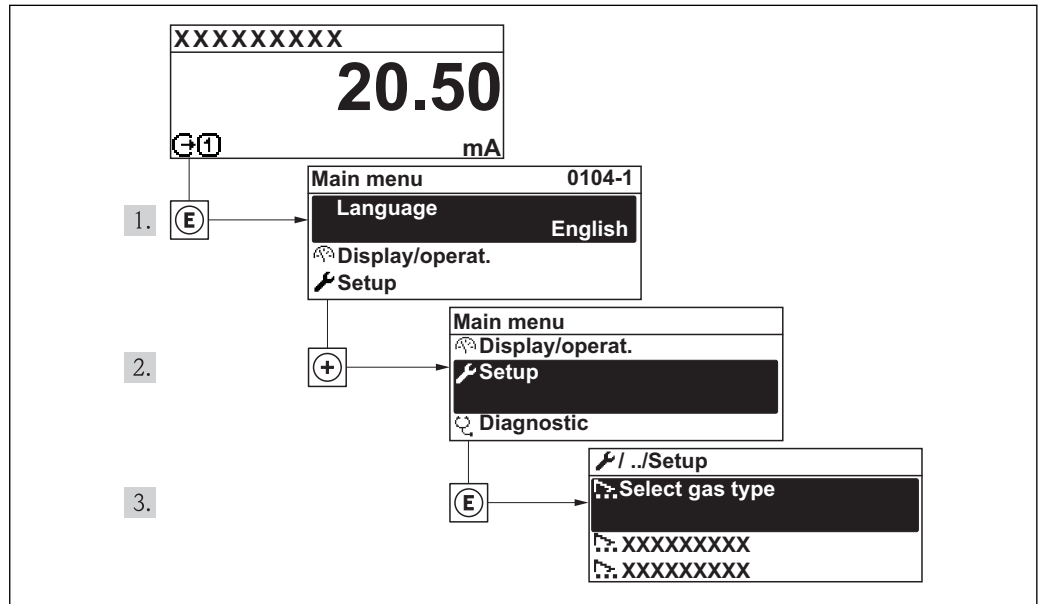

A0017371-EN

*Overview of the "Setup" menu*

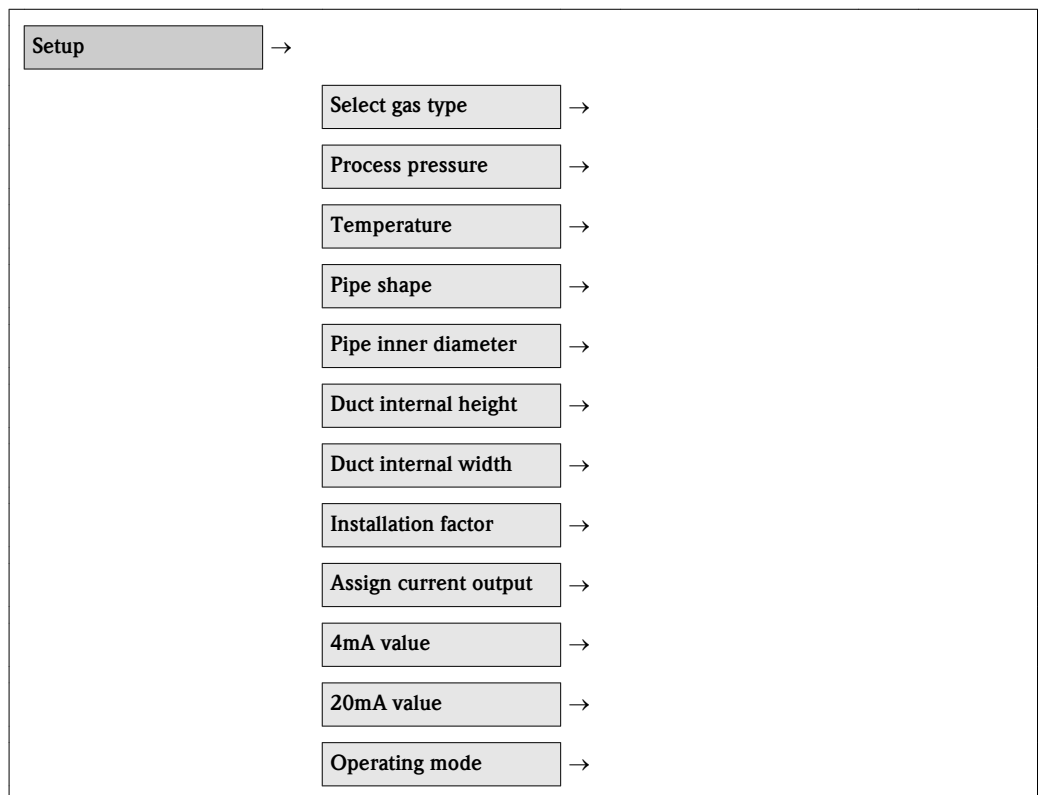

### 10.4.1 Selecting the gas type

#### Navigation path

"Setup" menu → Select gas type

#### Parameter overview with brief description

Parameter	Description	Selection/ User entry	Factory setting
Select gas type	Select the gas type for the measurement application.	Gas type choose list <ul style="list-style-type: none"> <li>■ Air</li> <li>■ Argon Ar</li> <li>■ Carbon dioxide CO2</li> <li>■ Nitrogen N2</li> </ul>	Air

### 10.4.2 Specifying the process pressure

#### Navigation path

"Setup" menu → Process pressure

#### Parameter overview with brief description

Parameter/	Description	Selection/ User entry	Factory setting
Process pressure	Process pressure value for calculating pressure-dependent gas properties	0.5 to 21.0 bar a (7.3 to 303 psi a)	Country-dependent: 1.0130 bar a (14.692 psi a)

### 10.4.3 Configuring the sensor data

#### Configuring the pipe shape

*Navigation path*

"Setup" menu → Pipe shape

*Parameter overview with brief description*

Parameter	Description	Selection/ User entry	Factory setting
Pipe shape	Select the shape of the pipe	Circular Rectangular	Circular

#### Configuring the pipe inner diameter

*Navigation path*

"Setup" menu → Pipe inner diameter

*Parameter overview with brief description*

Parameter	Description	Prerequisite	Selection/ User entry	Factory setting
Pipe inner diameter	(Enter the inner diameter of the pipe)	Only if the CIRCULAR pipe shape has been selected	80 to 1 500 mm	80 mm

#### Configuring the duct dimensions

*Navigation path*

"Setup" menu → Duct internal height

"Setup" menu → Duct internal width

*Parameter overview with brief description*

Parameter	Description	Prerequisite	Selection/ User entry	Factory setting
Duct internal height	Enter the height of a rectangular duct	Only if the RECTANGULAR pipe shape has been selected	50 to 3 000 mm	80 mm (3 in)
Duct internal width	Enter the width of a rectangular duct	Only if the RECTANGULAR pipe shape has been selected	50 to 3 000 mm	80 mm (3 in)

### 10.4.4 Determining the installation factor

**Navigation path**

"Setup" menu → Installation factor

**Parameter overview with brief description**

Parameter	Description	Selection/ User entry	Factory setting
Installation factor	The factor is multiplied by the mass flow to correct sub-optimum installations	0 to 9	1

## 10.4.5 Configuring the current output

### Navigation path

"Setup" menu →Assign current output

"Setup" menu →4mA value

"Setup" menu →20mA value

### Parameter overview with brief description

Parameter	Description	Selection/ User entry	Factory setting
Assign current output	Use this function to assign a measured variable or process variable to the current output	Mass flow Corrected volume flow FAD volume flow Temperature	Mass flow
4mA value	Enter the value for the 4 mA current. The value can be larger than or smaller than the 20 mA value assigned. Positive and negative values are permitted depending on the measured variable (e.g. mass flow) assigned.	Number with up to 3 decimal places from - to +. The unit depends on the measured variable assigned.	0
20mA value	Enter the value for the 20 mA current. The value can be larger than or smaller than the 4 mA value assigned. Positive and negative values are permitted depending on the measured variable (e.g. mass flow) assigned.	Number with up to 3 decimal places from - to +. The unit depends on the measured variable assigned.	Maximum calibrated full scale value

## 10.4.6 Configuring the pulse/frequency/switch output

### Navigation path

- "Setup" menu →Operating mode
- "Setup" menu →Assign frequency output
- "Setup" menu →Switch output function
- "Setup" menu →Assign pulse output

### Parameter overview with brief description

Parameter	Description	Selection/ User entry	Factory setting
Operating mode	Specify the output as a pulse, frequency or switch output.	<ul style="list-style-type: none"> <li>■ Pulse</li> <li>■ Frequency</li> <li>■ Switch</li> </ul>	Pulse
Assign frequency output	Select the process variable for the frequency output.	<ul style="list-style-type: none"> <li>■ Off</li> <li>■ Mass flow</li> <li>■ Corrected volume flow</li> <li>■ FAD volume flow</li> <li>■ Temperature</li> </ul>	Off
Measuring value at minimum frequency	Enter the measured value at the minimum frequency.	Depends on the process variable selected	-
Measuring value at maximum frequency	Specify the measured value at maximum frequency.	Depends on the process variable selected	-

Switch output function	Select the function for the switch output.	<ul style="list-style-type: none"> <li>■ Off</li> <li>■ On</li> <li>■ Diagnostic behavior</li> <li>■ Limit value</li> <li>■ Status</li> </ul>	Off
Assign limit	Select the process variable for the limit function.	<ul style="list-style-type: none"> <li>■ Mass flow</li> <li>■ Corrected volume flow</li> <li>■ FAD volume flow</li> <li>■ Temperature</li> <li>■ Totalizer</li> </ul>	Mass flow
Switch-off value	Enter the measured value for the switch-off value.	Depends on the process variable selected	-
Switch-on value	Enter the measured value for the switch-on value.	Depends on the process variable selected	-
Assign diagnostic behavior	Select the diagnostic behavior for the switch output.	<ul style="list-style-type: none"> <li>■ Alarm</li> <li>■ Alarm or warning</li> <li>■ Warning</li> </ul>	Alarm
Assign status	Select the device status for the switch output.	Low flow cut off	Low flow cut off
Assign pulse output	Select the process variable for the pulse output.	<ul style="list-style-type: none"> <li>■ Off</li> <li>■ Mass flow</li> <li>■ Corrected volume flow</li> <li>■ FAD volume flow</li> </ul>	Off
Pulse value	Enter the measured value for the pulse output.	Depends on the process variable selected	-

## 10.5 Advanced settings

The **Advanced setup** menu with its submenus contains all parameters needed for specific settings.

### Navigation path

"Setup" menu → Advanced setup

*Navigation to the "Advanced setup" submenu*

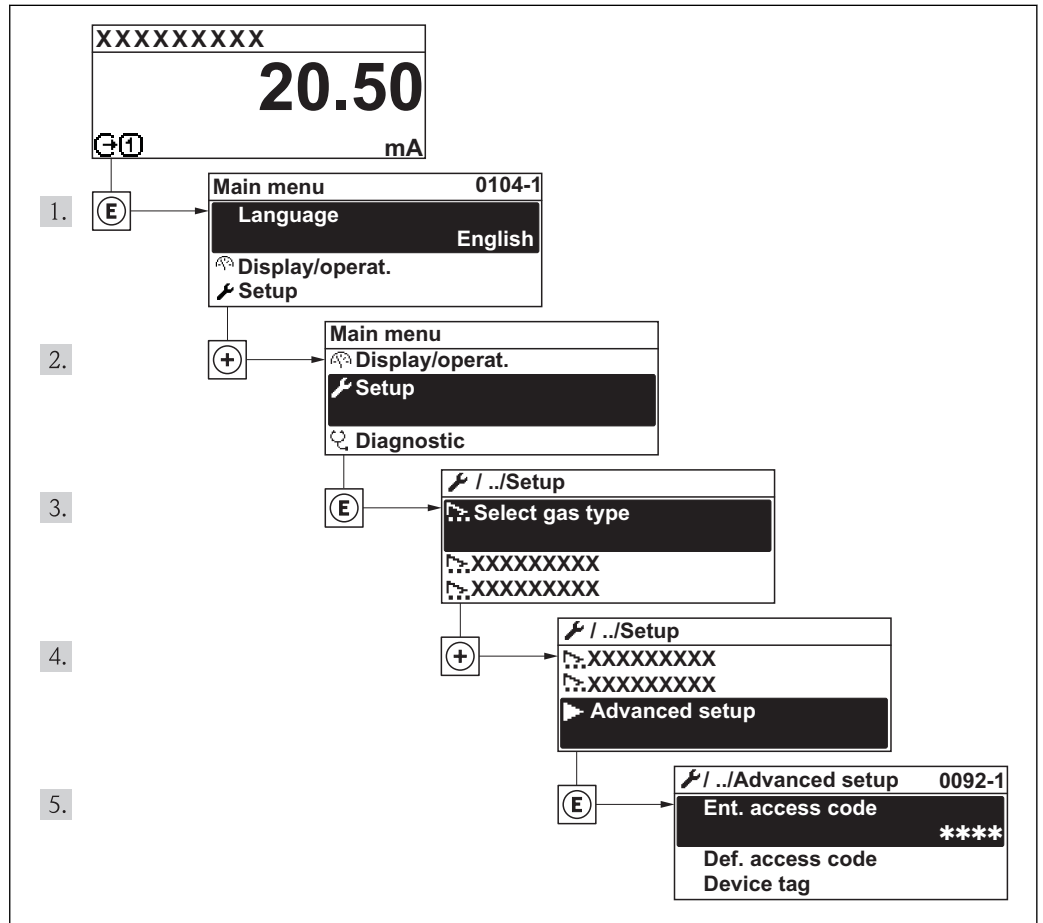

A0017372-EN

*Overview of the parameters and submenus in the "Advanced setup" menu*

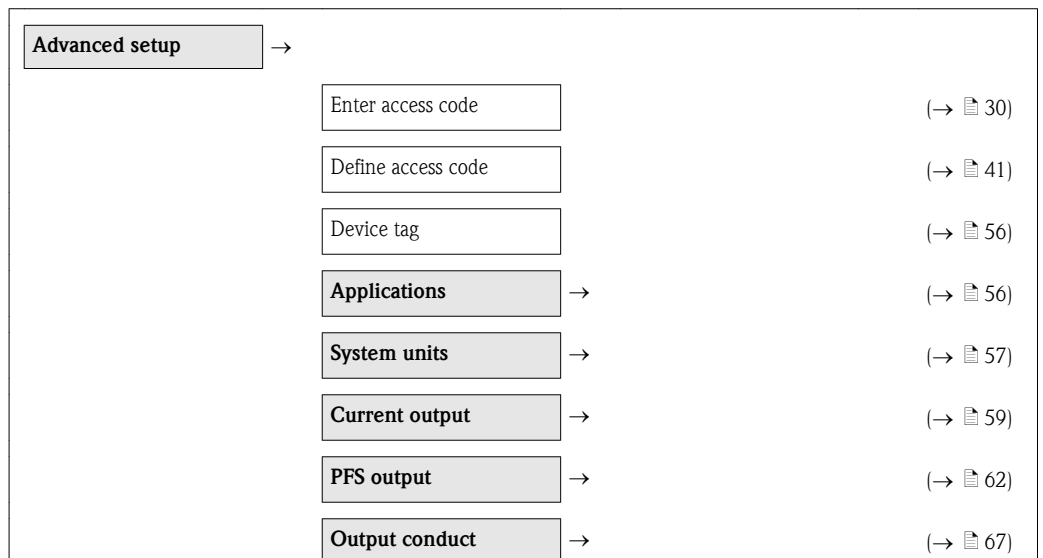

Low flow cut off	→	(→ 68)
Totalizer	→	(→ 69)
Display	→	(→ 49)
Conf. backup disp.	→	(→ 48)

### 10.5.1 Defining the tag name

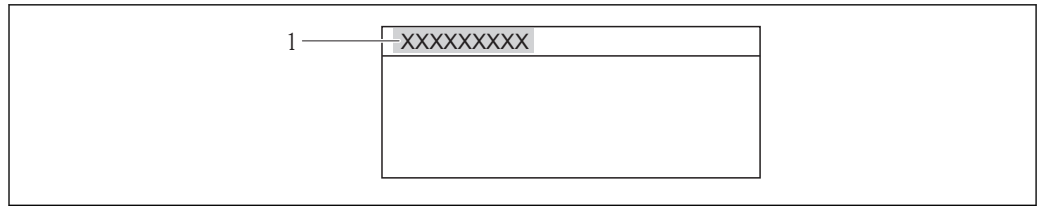

A0013375

1 Device tag

 The number of characters displayed depends on the characters used.

### 10.5.2 Configuring applications

#### Navigation path

"Setup" menu → "Advanced setup" → Applications

#### Parameter overview with brief description

Parameter	Description	Selection/ User entry	Factory setting
-----------	-------------	--------------------------	-----------------



Select gas type	Select the gas type for the measurement application.	Gas type choose list <ul style="list-style-type: none"> <li>■ Air</li> <li>■ Argon Ar</li> <li>■ Carbon dioxide CO2</li> <li>■ Nitrogen N2</li> </ul>	Air
Process pressure	Process pressure value for calculating pressure-dependent gas properties	0.5 to 21.0 bar a (7.3 to 303 psi a)	Country-dependent: <ul style="list-style-type: none"> <li>■ 1.01325 bar a</li> <li>■ 14.696 psi a</li> </ul>
Temperature	Use this function to view the process temperature currently measured.	None	-
Reference operating conditions	Select reference operating conditions for calculating the reference density	1013.25 mbar a, 0°C 1013.25 mbar a, 15°C 1013.25 mbar a, 20°C 1013.25 mbar a, 25°C 1000 mbar a, 0°C 1000 mbar a, 15°C 1000 mbar a, 20°C 1000 mbar a, 25°C 14.696 psi a, 59°F 14.696 psi a, 60°F 14.730 psi a, 60°F User-defined	Country-dependent: <ul style="list-style-type: none"> <li>■ 1013.25 mbar a, 0 °C</li> <li>■ 14.696 psi a, 59 °F</li> </ul>
Reference pressure	Enter the reference pressure for calculating the reference density	0.1 to 99 bar a (1.5 to 1 436 psi a)	Country-dependent: 1.0130 bar a (14.696 psi a)
Reference temperature	Enter the reference temperature for calculating the reference density	-50 to 150 °C (-58 to 423 °F°)	Country-dependent: <ul style="list-style-type: none"> <li>■ 0.0 °C</li> <li>■ 32 °F</li> </ul>
FAD conditions	Select reference operating conditions for calculating the FAD density (FAD = free air delivery)	1 000 mbar a, 20 °C 14.504 psi a, 68 °F User-defined	Country-dependent: <ul style="list-style-type: none"> <li>■ 1 000 mbar a, 20 °C</li> <li>■ 14.504 psi a, 68 °F</li> </ul>
FAD pressure	Enter the reference pressure for calculating the FAD density	0.1 to 99 bar a (1.5 to 1 436 psi a)	Country-dependent: <ul style="list-style-type: none"> <li>■ 1.000 bar a</li> <li>■ 14.504 psi a</li> </ul>
FAD temperature	Enter the reference temperature for calculating the FAD density	-50 to 150 °C (-58 to 423 °F°)	Country-dependent: <ul style="list-style-type: none"> <li>■ 20 °C</li> <li>■ 68 °F</li> </ul>

### 10.5.3 Setting the system units

In the **System units** submenu, you can configure the units of all measured values.

#### Navigation path

"Setup" menu → Advanced setup → System units

#### Structure of the submenu

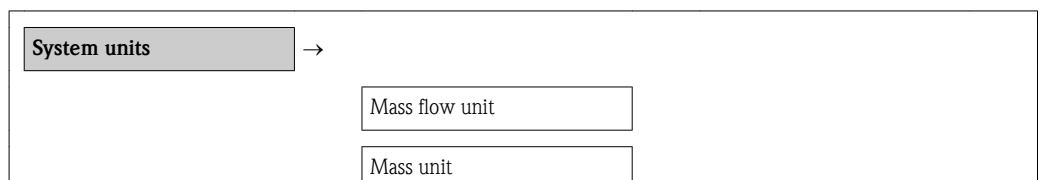

Corrected volume flow unit
Corrected volume unit
FAD volume flow unit
FAD volume unit
Density unit
Pressure unit
Temperature unit
Length unit

**Parameter overview with brief description**

Parameter	Description	Selection/ User entry	Factory setting
Mass flow unit	Select the unit for mass flow.  <i>Result</i> The selected unit applies for all outputs	Metric: Gram: g/s; g/min; g/h; g/day Kilogram: kg/s; kg/min; kg/h; kg/day Metric ton: t/s; t/min; t/h; t/day US: Ounce: oz/s; oz/min; oz/h; oz/day Pound: lb/s; lb/min; lb/h; lb/day ton: LTon/s; LTon/min; LTon/h; LTon/day ton: STon/s; STon/min; STon/h; STon/day Arbitrary unit (see text mass unit function): ___/s; ___/min; ___/h; ___/day	Country-dependent: ■ kg/h ■ lb/h
Mass unit	Select the unit for mass.	g kg t oz lb STon LTon User-defined	Country-dependent: ■ kg ■ lb

Parameter	Description	Selection/ User entry	Factory setting
Corrected volume flow unit	Select the unit for corrected volume flow.  <i>Result</i> The selected unit applies for all outputs	l/s l/min l/h l/d Nm <sup>3</sup> /s Nm <sup>3</sup> /min Nm <sup>3</sup> /h Nm <sup>3</sup> /d Sl/s Sl/min Sl/h Sl/d Sm <sup>3</sup> /s Sm <sup>3</sup> /min Sm <sup>3</sup> /h Sm <sup>3</sup> /d Scf/s Scf/min Scf/h Scf/d	Country-dependent: <ul style="list-style-type: none"> <li>■ Nm<sup>3</sup>/h</li> <li>■ Scf/min</li> </ul>
Corrected volume unit	Select the unit for volume.	l Nm <sup>3</sup> Sl Sm <sup>3</sup> Scf	Country-dependent <ul style="list-style-type: none"> <li>■ Nm<sup>3</sup></li> <li>■ Scf</li> </ul>
FAD volume flow unit	Select the unit for the FAD volume flow.  <i>Result</i> The selected unit applies for all outputs	l FAD/s l FAD/min l FAD/h l FAD/d m <sup>3</sup> FAD/s m <sup>3</sup> FAD/min m <sup>3</sup> FAD/h m <sup>3</sup> FAD/d cf FAD/s cf FAD/min cf FAD/h cf FAD/d	Country-dependent <ul style="list-style-type: none"> <li>■ m<sup>3</sup> FAD/h</li> <li>■ cf FAD/min</li> </ul>
FAD volume unit	Select the unit for standard volume.	l FAD m <sup>3</sup> FAD cf FAD	Country-dependent: <ul style="list-style-type: none"> <li>■ m<sup>3</sup> FAD</li> <li>■ cf FAD</li> </ul>
Density unit	Select the unit for density.  <i>Result</i> The selected unit applies for all outputs	g/cm <sup>3</sup> kg/dm <sup>3</sup> kg/l kg/m <sup>3</sup> lb/cf	Country-dependent <ul style="list-style-type: none"> <li>■ kg/m<sup>3</sup></li> <li>■ lb/cf</li> </ul>
Pressure unit	Select the unit for process pressure.	kPa a MPa a bar a psi a mbar	Country-dependent: <ul style="list-style-type: none"> <li>■ bar a</li> <li>■ psi a</li> </ul>
Temperature unit	Select the unit for temperature.  <i>Result</i> The selected unit applies for all outputs	°C °F K °R	Country-dependent: <ul style="list-style-type: none"> <li>■ °C (Celsius)</li> <li>■ °F (Fahrenheit)</li> </ul>
Length unit	Select the unit of length for the nominal diameter.	mm m in ft	Country-dependent: <ul style="list-style-type: none"> <li>■ mm</li> <li>■ in</li> </ul>

### 10.5.4 Configuring the current output

In the **Current output** submenu, you can configure the values for the current output.

**Navigation path**

"Setup" menu → Advanced setup → Current output

**Structure of the submenu**

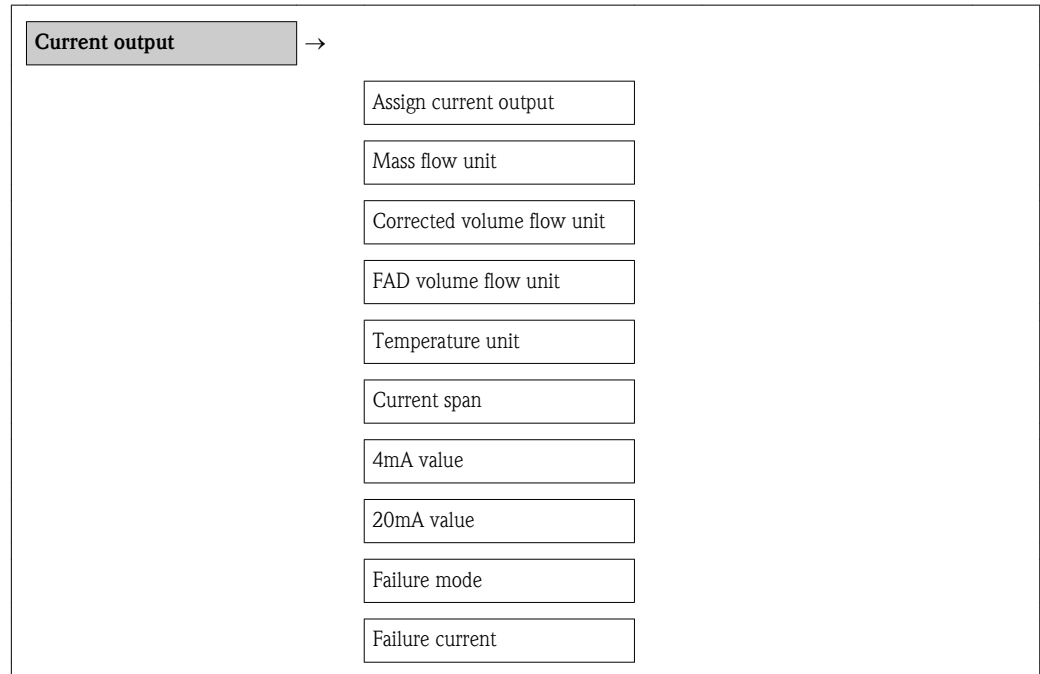

**Parameter overview with brief description**

Parameter	Description	Selection/ User entry	Factory setting
Assign current output	Use this function to assign a measured variable or process variable to the current output	Mass flow Corrected volume flow FAD volume flow Temperature	Mass flow
Mass flow unit	Select the unit for mass.	Metric: Gram: g/s; g/min; g/h; g/day Kilogram: kg/s; kg/min; kg/h; kg/day Metric ton: t/s; t/min; t/h; t/day US: Ounce: oz/s; oz/min; oz/h; oz/day Pound: lb/s; lb/min; lb/h; lb/day ton: LTon/s; LTon/min; LTon/h; LTon/day ton: STon/s; STon/min; STon/h; STon/day Arbitrary unit (see TEXT mass unit function): ___ _/s; ___/min; ___ _/h; ___/day	Country-dependent: ■ kg/h ■ lb/h

Parameter	Description	Selection/ User entry	Factory setting
Corrected volume flow unit	Select the unit for corrected volume flow.  <i>Result</i> The selected unit applies for all outputs	Unit choose list NI/s NI/min NI/h NI/d Nm <sup>3</sup> /s Nm <sup>3</sup> /min Nm <sup>3</sup> /h Nm <sup>3</sup> /d Sl/s Sl/min Sl/h Sl/d Sm <sup>3</sup> /s Sm <sup>3</sup> /min Sm <sup>3</sup> /h Sm <sup>3</sup> /d Scf/s Scf/min Scf/h Scf/d	Country-dependent: ■ Nm <sup>3</sup> /h ■ Scf/min
FAD volume flow unit	Select the unit for the FAD volume flow.  <i>Result</i> The selected unit applies for all outputs	Unit choose list l FAD/s l FAD/min l FAD/h l FAD/d m <sup>3</sup> FAD/s m <sup>3</sup> FAD/min m <sup>3</sup> FAD/h m <sup>3</sup> FAD/d cf FAD/s cf FAD/min cf FAD/h cf FAD/d	Country-dependent: ■ m <sup>3</sup> FAD/h ■ cf FAD/min
Temperature unit	Select the unit for temperature.  <i>Result</i> The selected unit applies for all outputs	°C °F K °R	Country-dependent: ■ °C (Celsius) ■ °F (Fahrenheit)
Current span	Select the current range for the process value output and for the upper/lower level for signal on alarm	Options 4 to 20mA HART NAMUR 4 to 20mA HART US 4 to 20mA FIXED CURRENT	4 to 20mA HART NAMUR
4mA value	Enter the value for the 4 mA current. The value can be larger than or smaller than the 20 mA value assigned. Positive and negative values are permitted depending on the measured variable (e.g. mass flow) assigned.	Number with up to 3 decimal places from - to +. The unit depends on the measured variable assigned.	0
20mA value	Enter the value for the 20 mA current. The value can be larger than or smaller than the 4 mA value assigned. Positive and negative values are permitted depending on the measured variable (e.g. mass flow) assigned.	Number with up to 3 decimal places from - to +. The unit depends on the measured variable assigned.	Nominal size dependent

Parameter	Description	Selection/ User entry	Factory setting
Failure mode	Select the value the current output adopts in an alarm condition. Prerequisite: The "FIXED CURRENT" option was not selected in the CURRENT SPAN function (xxxx).	<ul style="list-style-type: none"> <li>■ Min. current</li> <li>■ Max. current</li> <li>■ Last valid value</li> <li>■ Actual value</li> <li>■ Defined value</li> </ul>	Max. current
Failure current	Select the current value the current output adopts in an alarm condition.	Floating point number with 2 decimal places in the range 3.6 to 22.5 mA	22.5 mA

### 10.5.5 Configuring the PFS output

In the **PFS output** submenu, you can configure the values for the current output.

#### Navigation path

"Setup" menu → Advanced setup → PFS output

#### Structure of the submenu

PFS output

 →
 

Operating mode

Assign pulse

Unit

Pulse value

Pulse width

Failure mode

Invert output signal

Assign frequency

Unit

Minimum frequency value

Maximum frequency value

Value at minimum frequency

Value at maximum frequency

Failure mode

Invert output signal

Switch output function

(On/Off)

(Diagnostic behavior)

(Limit value)

Assign diagnostic behavior

Assign limit

(Status)	Switch-on value
	Switch-off value
	Assign status
	Switch-on delay
	Switch-off delay
	Failure mode
	Switch status
	Invert output signal

**Parameter overview with brief description**

Parameter	Description	Selection/ User entry	Factory setting
Operating mode	Specify the output as a pulse, frequency or switch output.	<ul style="list-style-type: none"> <li>■ Pulse</li> <li>■ Frequency</li> <li>■ Switch</li> </ul>	Pulse
Assign pulse output	Select the process variable for the pulse output.	<ul style="list-style-type: none"> <li>■ Off</li> <li>■ Mass flow</li> <li>■ Corrected volume flow</li> <li>■ FAD volume flow</li> </ul>	Off
Assign frequency output	Select the process variable for the frequency output.	<ul style="list-style-type: none"> <li>■ Off</li> <li>■ Mass flow</li> <li>■ Corrected volume flow</li> <li>■ FAD volume flow</li> <li>■ Temperature</li> </ul>	Off
Assign switch output	Select the function for the switch output.	<ul style="list-style-type: none"> <li>■ Off</li> <li>■ On</li> <li>■ Diagnostic behavior</li> <li>■ Limit value</li> <li>■ Status</li> </ul>	Off
Assign diagnostic behavior	Select the diagnostic behavior for the switch output.	<ul style="list-style-type: none"> <li>■ Alarm</li> <li>■ Alarm or warning</li> <li>■ Warning</li> </ul>	Alarm
Assign limit	Select the process variable for the limit function.	<ul style="list-style-type: none"> <li>■ Mass flow</li> <li>■ Corrected volume flow</li> <li>■ FAD volume flow</li> <li>■ Totalizer</li> </ul>	Mass flow
Assign status	Select the device status for the switch output.	Low flow cut off	Low flow cut off

Parameter	Description	Selection/ User entry	Factory setting
Mass flow unit	Select the unit for mass flow. <i>Result</i> The selected unit applies for all outputs	Metric: Gram: g/s; g/min; g/h; g/day Kilogram: kg/s; kg/min; kg/h; kg/day Metric ton: t/s; t/min; t/h; t/day US: Ounce: oz/s; oz/min; oz/h; oz/day Pound: lb/s; lb/min; lb/h; lb/day ton: LTon/s; LTon/min; LTon/h; LTon/day ton: STon/s; STon/min; STon/h; STon/day Arbitrary unit (see Text mass unit function: ___ _/s; ___/min; ___ _/h; ___/day	Country-dependent: ■ kg/h ■ lb/h
Mass unit	Select the unit for mass. <i>Result</i> The selected unit is taken from: Mass flow unit	g kg t oz lb STon LTon User-defined	Country-dependent: ■ kg ■ lb
FAD volume flow unit	Use this function to select the preferred unit that is to be displayed for the FAD volume flow. The following time units can be selected: s = second, m = minute, h = hour, d = day Select the unit for the FAD volume flow. <i>Result</i> The selected unit applies for all outputs	1 FAD/s 1 FAD/min 1 FAD/h 1 FAD/d m <sup>3</sup> FAD/s m <sup>3</sup> FAD/min m <sup>3</sup> FAD/h m <sup>3</sup> FAD/d cf FAD/s cf FAD/min cf FAD/h cf FAD/d	Country-dependent: ■ m <sup>3</sup> FAD/h ■ cf FAD/min
FAD volume unit	Select the unit for the FAD volume unit.	1 FAD m <sup>3</sup> FAD cf FAD	Country-dependent: ■ m <sup>3</sup> FAD ■ cf FAD
Corrected volume flow unit	Select the unit for corrected volume flow. <i>Result</i> The selected unit applies for all outputs	Nl/s Nl/min Nl/h Nl/d Nm <sup>3</sup> /s Nm <sup>3</sup> /min Nm <sup>3</sup> /h Nm <sup>3</sup> /d Sl/s Sl/min Sl/h Sl/d Sm <sup>3</sup> /s Sm <sup>3</sup> /min Sm <sup>3</sup> /h Sm <sup>3</sup> /d Scf/s Scf/min Scf/h Scf/d	Country-dependent: ■ Nm <sup>3</sup> /h ■ scf/min (us)



Parameter	Description	Selection/ User entry	Factory setting
Corrected volume unit	Select the unit for standard volume. The unit selected here also applies for all outputs	Nl Nm <sup>3</sup> Sl Sm <sup>3</sup> Scf	Country-dependent: ■ Nm <sup>3</sup> ■ Scf
Temperature unit	Select the unit for temperature.  <i>Result</i> The selected unit applies for: – Current outputs – Reference temperature – Simulation process variable	°C °F K °R	Country-dependent: ■ °C (Celsius) ■ °F (Fahrenheit)
Pulse value	Enter the measured value for the pulse output.	Depends on the process variable selected	-
Pulse width	Specify the duration of the output pulse.	0.5 to 2 000 msec	20 msec
Failure mode	Select the value the current output adopts in an alarm condition. Prerequisite: The "FIXED CURRENT" option was not selected in the CURRENT SPAN function (xxxx).	■ Min. current ■ Max. current ■ Last valid value ■ Actual value ■ Defined value	Max. current
Minimum frequency value	Enter the minimum frequency value.	0 to 1 000 Hertz	0 Hertz
Maximum frequency value	Enter the maximum frequency value.	0 to 1 000 Hertz	1 000 Hertz
Measuring value at minimum frequency	Enter the measured value at the minimum frequency.	Depends on the process variable selected	-
Measuring value at maximum frequency	Specify the measured value at maximum frequency.	Depends on the process variable selected	-
Failure mode	Specify the output behavior in the event of a device alarm	■ 0 Hertz ■ Actual value ■ Defined value	0 Hertz
Failure frequency	Enter the value for the frequency output in the event of a device alarm	0 to 1 250 Hertz	0 Hertz
Switch-on value	Enter the measured value for the switch-on value.	Depends on the process variable selected	-
Switch-off value	Enter the measured value for the switch-off value.	Depends on the process variable selected	-
Switch-on delay	Specify the delay time for switching on the switch output	0.0 to 100.0 sec	0 sec
Switch-off delay	Specify the delay time for switching off the switch output	0.0 to 100.0 sec	0 sec

Parameter	Description	Selection/ User entry	Factory setting
Failure mode	Specify the output behavior in the event of a device alarm Failsafe mode, The failsafe mode defines how the pulse output responds to a status message which is supposed to act on the status output.	Current status Open Closed	Open
Invert output signal	Invert the output signal	Yes No	No

### 10.5.6 Configuring the output conditioning

The damping and the step response time can be configured in the **Display behavior** submenu.

#### Navigation path

"Setup" menu → Advanced setup → Output conditioning

#### Structure of the submenu

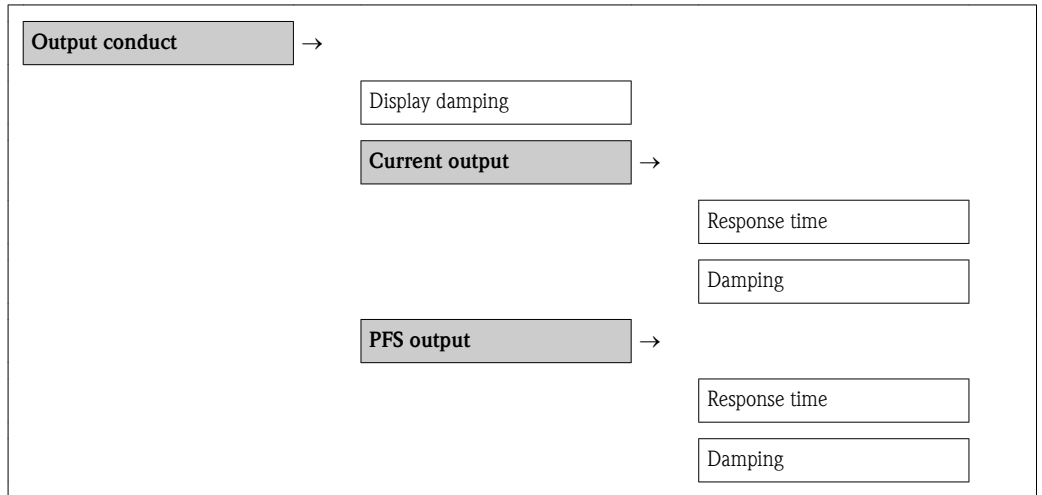

#### Parameter overview with brief description

Parameter	Description	Selection/ User entry	Factory setting
Display damping	Set the reaction time of the local display to fluctuations in the measured value.	0.0 to 999.9 sec	0.0
Response time Output	Displays the calculated step response time	-	0
Output damping	Set the reaction time of the output signal to fluctuations in the measured value.	0.0 to 999.9 sec	0.0

## 10.5.7 Configuring the low flow cut off

### Navigation path

"Setup" menu → "Advanced setup" menu → Low flow cut off

### Structure of the submenu

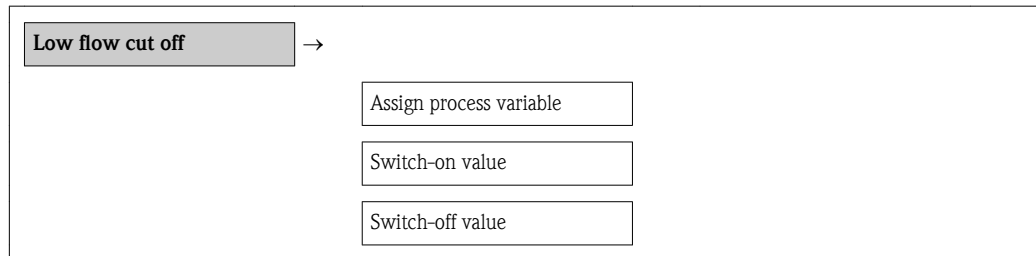

### Parameter overview with brief description

Parameter	Description	Selection/ User entry	Factory setting
Assign process variable	Select the process variable for low flow cut off.	<ul style="list-style-type: none"> <li>■ Off</li> <li>■ Mass flow</li> <li>■ Corrected volume flow</li> <li>■ FAD volume flow</li> </ul>	Off
On-value, low flow cut off	Enter the on value for low flow cut off	Max. 15-digit, positive floating-point number	Nominal size dependent 1 % of calibrated full scale value
Off value low flow cutoff	Enter the off value for low flow cut off	0 to 100 %	50 %

### 10.5.8 Configuring the totalizer

You can configure the totalizer in the **Totalizer** submenu.

#### Navigation path

"Setup" menu → Advanced setup → Totalizer

#### Structure of the submenu

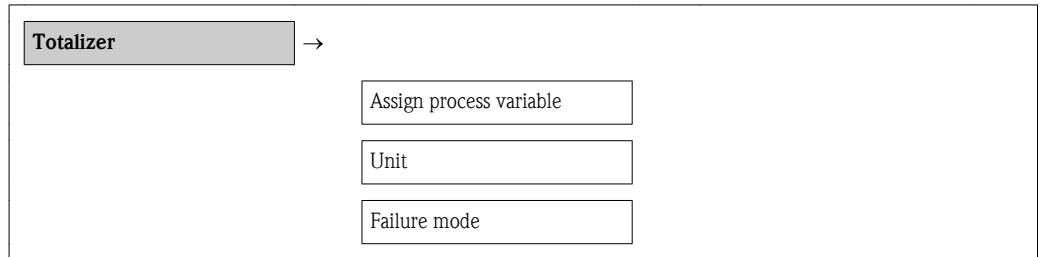

#### Parameter overview with brief description

Parameter	Prerequisite	Description	Selection/ User entry	Factory setting
Assign process variable	-	Select process variable for totalizer.  <i>Result</i> The selection determines the choose list of the <b>Unit</b> parameter.	<ul style="list-style-type: none"> <li>■ Off</li> <li>■ Mass flow</li> <li>■ Corrected volume flow</li> <li>■ FAD volume flow</li> </ul>	Mass flow
Unit	One of the following options is selected in the <b>Assign process variable</b> parameter: <ul style="list-style-type: none"> <li>■ Mass flow</li> <li>■ Corrected volume flow</li> <li>■ FAD volume flow</li> </ul>	Select the unit for the process variable of the totalizer.	Unit choose list	Country-dependent: <ul style="list-style-type: none"> <li>■ kg</li> <li>■ lb</li> </ul>
Failure mode	One of the following options is selected in the <b>Assign process variable</b> parameter: <ul style="list-style-type: none"> <li>■ Mass flow</li> <li>■ Corrected volume flow</li> <li>■ FAD volume flow</li> </ul>	Define how the totalizer behaves in an alarm condition.	<ul style="list-style-type: none"> <li>■ Stop</li> <li>■ Actual value</li> <li>■ Last valid value</li> </ul>	Stop

### 10.5.9 Configuring the local display

#### Navigation path

"Setup" menu → "Advanced setup" menu → "Display" menu

#### Parameter overview with brief description

Parameter	Description	Selection/ User entry	Factory setting
Format display	Select how measured values are shown on the display.	<ul style="list-style-type: none"> <li>■ 1 value, max. size</li> <li>■ 1 bargraph + 1 value</li> <li>■ 2 values</li> <li>■ 1 value large + 2 values</li> <li>■ 4 values</li> </ul>	1 value, max. size

Value 1 display	Select the measured value that is shown on the local display.	<ul style="list-style-type: none"> <li>■ Mass flow</li> <li>■ Corrected volume flow</li> <li>■ FAD volume flow</li> <li>■ Temperature</li> <li>■ Totalizer</li> <li>■ Current output</li> </ul>	Mass flow
0% bargraph value 1	Enter the 0% value to be shown on the bargraph display for the measured value 1.	Floating-point number with sign	0
100% bargraph value 1	Enter the 100% value to be shown on the bargraph display for the measured value 1.	Floating-point number with sign	1
Decimal places 1	Select the number of decimal places for the display value.	<ul style="list-style-type: none"> <li>x</li> <li>x.x</li> <li>x.xx</li> <li>x.xxx</li> <li>x.xxxx</li> </ul>	x.xx
Value 2 display	Select the measured value that is shown on the local display.	<ul style="list-style-type: none"> <li>■ None</li> <li>■ Mass flow</li> <li>■ Corrected volume flow</li> <li>■ FAD volume flow</li> <li>■ Temperature</li> <li>■ Totalizer</li> <li>■ Current output</li> </ul>	None
Decimal places 2	Select the number of decimal places for the display value.	<ul style="list-style-type: none"> <li>x</li> <li>x.x</li> <li>x.xx</li> <li>x.xxx</li> <li>x.xxxx</li> </ul>	x.xx
Value 3 display	Select the measured value that is shown on the local display.	<ul style="list-style-type: none"> <li>■ None</li> <li>■ Mass flow</li> <li>■ Corrected volume flow</li> <li>■ FAD volume flow</li> <li>■ Temperature</li> <li>■ Totalizer</li> <li>■ Current output</li> </ul>	None
0% bargraph value 3	Enter the 0% value to be shown on the bargraph display for the measured value 3.	Floating-point number with sign	0
100% bargraph value 3	Enter the 100% value to be shown on the bargraph display for the measured value 3.	Floating-point number with sign	0
Decimal places 3	Select the number of decimal places for the display value.	<ul style="list-style-type: none"> <li>x</li> <li>x.x</li> <li>x.xx</li> <li>x.xxx</li> <li>x.xxxx</li> </ul>	x.xx
Value 4 display	Select the measured value that is shown on the local display.	<ul style="list-style-type: none"> <li>■ None</li> <li>■ Mass flow</li> <li>■ Corrected volume flow</li> <li>■ FAD volume flow</li> <li>■ Temperature</li> <li>■ Totalizer</li> <li>■ Current output</li> </ul>	None

Decimal places 4	Select the number of decimal places for the display value.	x x.x x.xx x.xxx x.xxxx	x.xx
Display interval	Set time measured values are shown on display if display alternates between values.	1 to 10	5
Display damping	Set the reaction time of the local display to fluctuations in the measured value.	0.0 to 999.9	0
Header	Select header contents on local display.	Device tag Free text	Device tag
Header text	Select text for header on local display.	Free text	-
Separator	Select decimal separator for displaying numerical values.	. ,	.

## 10.6 Configuration management

After commissioning, you can save the current device configuration, copy it to another measuring point or restore the previous device configuration.

You can do so using the **Configuration management** parameter and the related options found in the **Conf. backup display** submenu.

### Navigation path

"Setup" menu → Advanced setup → Conf. backup disp.

 While this action is in progress, the configuration cannot be edited via the local display and a message on the processing status appears on the display.

### Structure of the submenu

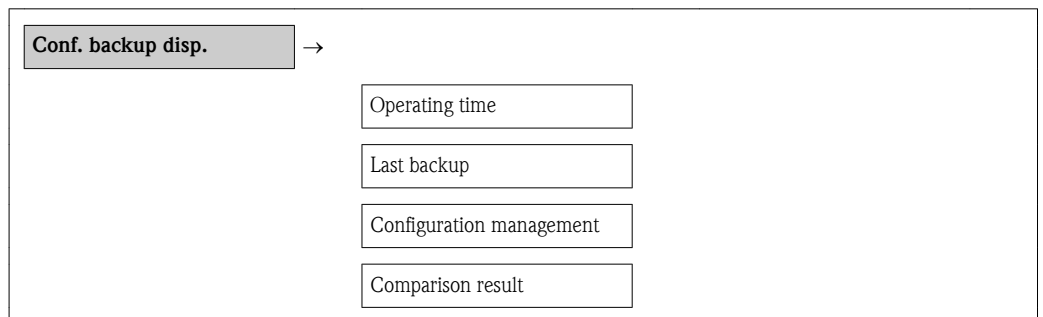

### Parameter overview with brief description

Parameter	Description	Selection/Display	Factory setting
Operating time	Indicates how long the device has been in operation up to this point.	Days (d), hours (h), minutes (m), seconds (s)	-
Last backup	Indicates when the last data backup was saved to the display module	Days (d), hours (h), minutes (m), seconds (s)	-

Configuration management	Select action for managing the device data in the display module	<ul style="list-style-type: none"> <li>■ Cancel</li> <li>■ Execute backup</li> <li>■ Restore</li> <li>■ Duplicate</li> <li>■ Compare</li> <li>■ Clear backup data</li> </ul>	Cancel
Comparison result	Comparison between present device data and display backup	<ul style="list-style-type: none"> <li>■ Settings identical</li> <li>■ Settings not identical</li> <li>■ No backup available</li> <li>■ Backup settings corrupt</li> <li>■ Check not done</li> <li>■ Dataset incompatible</li> </ul>	Check not done

## 10.7 Simulation

The **Simulation** submenu enables you to simulate, without a real flow situation, various process variables in the process and the device alarm mode and to verify downstream signal chains (switching valves or closed-control loops).

### Navigation path

"Diagnostics" menu → Simulation

### Structure of the submenu

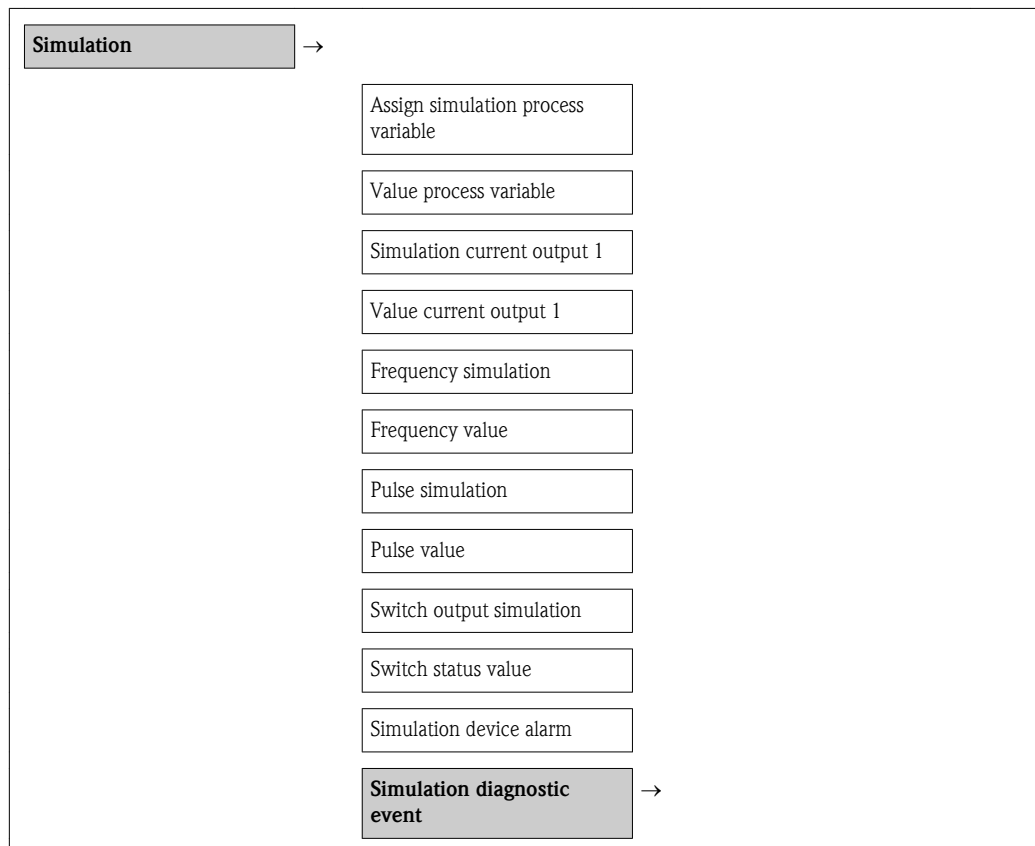

### Parameter overview with brief description

Parameter	Prerequisite	Description	Selection/ User entry	Factory setting
-----------	--------------	-------------	--------------------------	-----------------



Assign simulation process variable	-	Select a process variable for the simulation process that is activated.	<ul style="list-style-type: none"> <li>■ Off</li> <li>■ Mass flow</li> <li>■ Corrected volume flow</li> <li>■ FAD volume flow</li> <li>■ Temperature</li> </ul>	Off
Value process variable	One of the following options must be selected in the <b>Assign simulation process variable</b> parameter: <ul style="list-style-type: none"> <li>■ Mass flow</li> <li>■ Corrected volume flow</li> <li>■ FAD volume flow</li> <li>■ Temperature</li> </ul>	Enter the simulation value for the selected process variable.	Depends on the process variable selected	-
Simulation current output	-	Switch simulation of the current output on and off.	<ul style="list-style-type: none"> <li>■ On</li> <li>■ Off</li> </ul>	Off
Value current output	The <b>On</b> option is selected in the <b>Simulation current output</b> parameter.	Enter the current value for simulation.	3.6 to 22.5 mA	Current value currently measured
Frequency simulation	<b>Frequency</b> must be selected in the <b>Operating mode</b> parameter.	Switch simulation of the frequency output on and off.	<ul style="list-style-type: none"> <li>■ On</li> <li>■ Off</li> </ul>	Off
Frequency value	The <b>On</b> option is selected in the <b>Frequency simulation</b> parameter.	Enter the frequency for simulation.	0.0 to 1 250 Hz	Frequency currently measured
Pulse simulation	<b>Pulse</b> must be selected in the <b>Operating mode</b> parameter.	Pulse output simulation can be switched on and off in this way.	<ul style="list-style-type: none"> <li>■ On</li> <li>■ Off</li> </ul>	Off
Pulse value	The <b>On</b> option is selected in the <b>Pulse simulation</b> parameter.	Enter the pulse counter value for the simulation and display the current counter value	<ul style="list-style-type: none"> <li>■ Off</li> <li>■ Fixed value</li> <li>■ Down-count. value</li> </ul>	0
Switch output simulation	<b>Switch</b> must be selected in the <b>Operating mode</b> parameter.	Switch simulation of the switch output on and off.	<ul style="list-style-type: none"> <li>■ On</li> <li>■ Off</li> </ul>	Off
Switch value	The <b>On</b> option is selected in the <b>Switch output simulation</b> parameter.	Enter the current value for simulation.	Open Closed	Open
Simulation device alarm	-	Switch the device alarm on and off.	<ul style="list-style-type: none"> <li>■ On</li> <li>■ Off</li> </ul>	Off

## 10.8 Protecting settings from unauthorized access

The following options exist for protecting the configuration of the measuring device from unintentional modification after commissioning:

- Write protection via access code (→ [73](#))
- Write protection via write protection switch (→ [73](#))
- Write protection via keypad lock (→ [30](#))

### 10.8.1 Write protection via access code

Using the customer-specific access code, the parameters for the measuring device configuration are write-protected and their values can no longer be changed via local operation.

#### Define access code



1. Navigating to the "Define access code" parameter: Setup → Advanced setup → Def. access code
2. Define a max. 4-digit numeric code as an access code.
  - ✓ The -symbol appears in front of all write-protected parameters.

#### Parameters that can always be changed

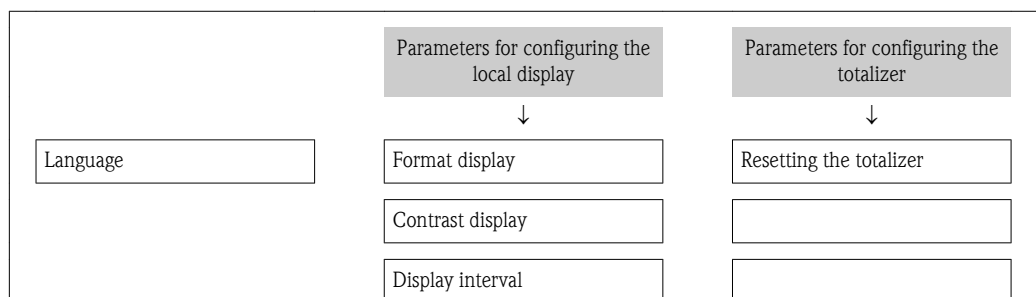
The write protection does not include certain parameters that do not affect the measurement. Despite the defined access code, these parameters can always be modified even if the other parameters are locked.



The device automatically locks the write-protected parameters again if a key is not pressed for 10 minutes in the navigation and editing view. The device locks the write-protected parameters automatically after 60 s if the user skips back to the measured value display mode from the navigation and editing view.

-  If write access is activated via access code, it can be also be deactivated only via the access code (→ [41](#)).
- In the "Description of Device Parameters" documents, each write-protected parameter is identified with the -symbol.

### 10.8.2 Write protection via write protection switch

Unlike write protection via user-specific access code, this allows write access to the entire operating menu - other than the **Contrast display** parameter - to be locked.

The values of the parameters are still visible, but can no longer be changed (except for **Contrast display**), either via the local display, the service interface (CDI) or HART protocol.

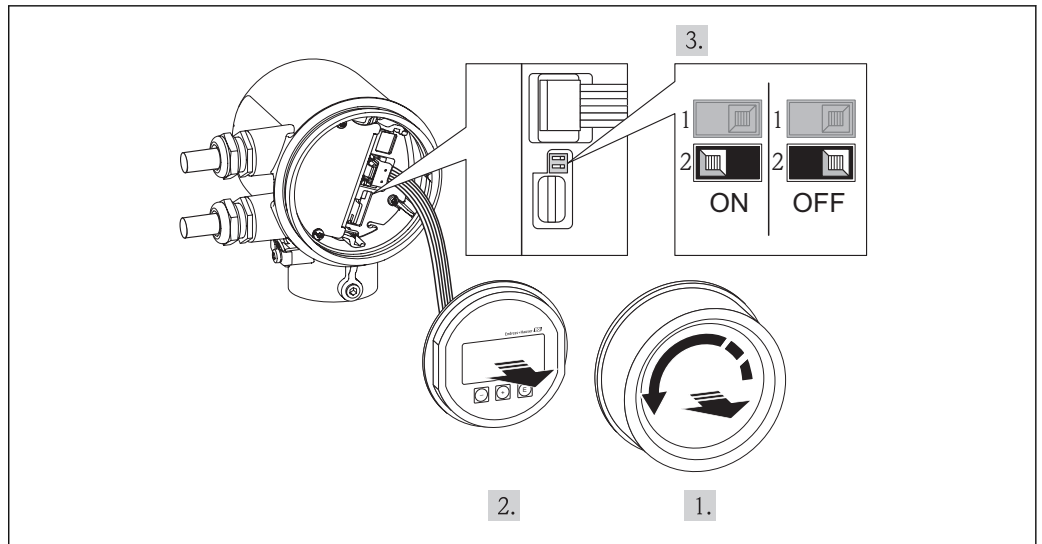

A0017255

1. Unscrew the electronics compartment cover.
2. Pull out the display module with a gentle rotational movement.
- 3.

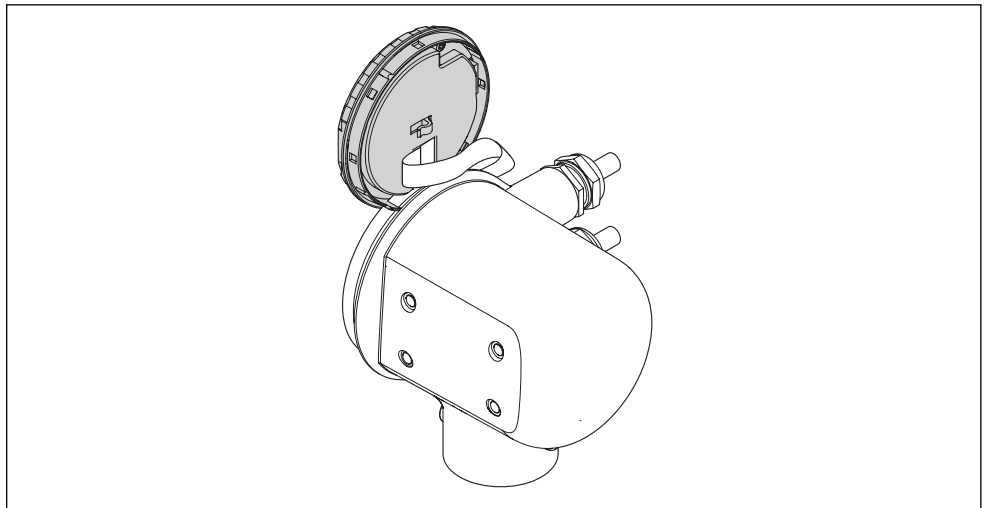

A0017375

To make it easier to access the lock switch, attach the display module to the edge of the electronics compartment.

4. Setting the write protection switch (WP) on the main electronics module to the ON position enables the hardware write protection. Setting the write protection switch (WP) on the main electronics module to the OFF position (factory setting) disables the hardware write protection.
  - ✓ If the hardware write protection is enabled, the  symbol appears before the parameters in the header of the measured value display and in the navigation view.

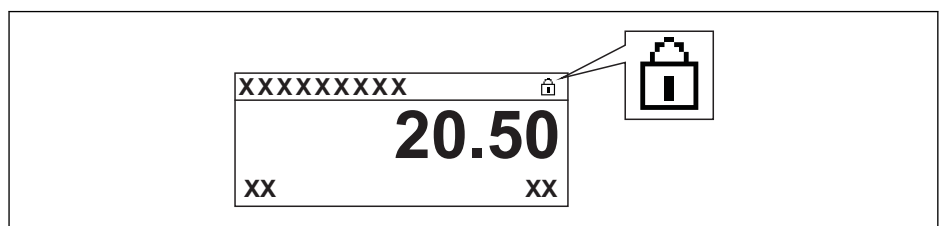

A0015870

If the hardware write protection is disabled, the  symbol does not appear before the parameters in the header of the measured value display and in the navigation view.

5. Feed the ribbon cable into the gap between the housing and electronics module and plug the display module into the electronics compartment in the desired direction until it engages.
6. Screw down the electronics compartment cover

## 11 Operation

### 11.1 Adjusting the operating language

See the "Commissioning" section for information on how to set the operating language (→  48).

### 11.2 Configuring the display

- Basic settings for local display
- Advanced settings for local display (→  55)

#### 11.2.1 Navigation path

"Display/operat." menu

"Display" submenu

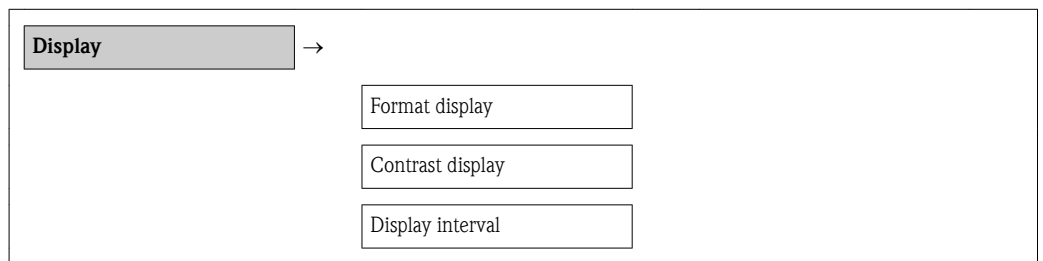

#### 11.2.2 Parameter overview with brief description

Parameter	Description	Selection/ User entry	Factory setting
Format display	Select how measured values are shown on the display.	<ul style="list-style-type: none"> <li>■ 1 value, max. size</li> <li>■ 1 bargraph + 1 value</li> <li>■ 2 values</li> <li>■ 1 value large + 2 values</li> <li>■ 4 values</li> </ul>	1 value, max. size
Contrast display	Adjust the contrast of the local display to ambient conditions (reading angle).	20 to 50 %	30 %
Display interval	Set time measured values are shown on display if display alternates between values.	1 to 10	5

### 11.3 Reading measured values

You can read all measured values using the **Measured values** menu.

#### Navigation path

Diagnostics → Measured values

#### 11.3.1 Process variables

The **Process variables** submenu contains all the parameters needed to display the current measured values for every process variable.

**Navigation path**

"Diagnostics" menu → Measured values → Process variables

**Temperature display navigation path**

The temperature display can also be viewed directly in the Setup menu:

"Setup" menu → Temperature

*Structure of the submenu*

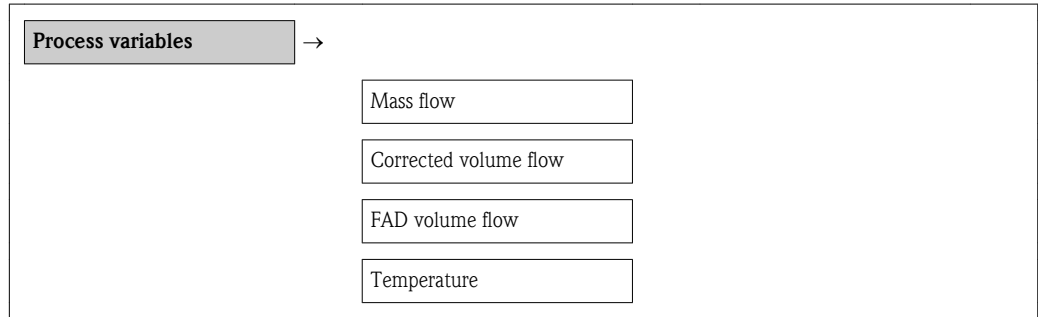

*Parameter overview with brief description*

Parameter	Description	Display
Mass flow	Displays the mass flow currently calculated	Floating-point number with sign
Corrected volume flow	Displays the calculated volume flow	Floating-point number with sign
FAD volume flow	Displays the FAD volume flow currently calculated	Floating-point number with sign
Temperature	Displays the current process temperature	Floating-point number with sign

**11.3.2 Totalizer**

The **Totalizer** submenu contains all the parameters needed to display the current measured values for every totalizer.

**Navigation path**

"Diagnostics" menu → Measured values → Totalizer

**Structure of the submenu**

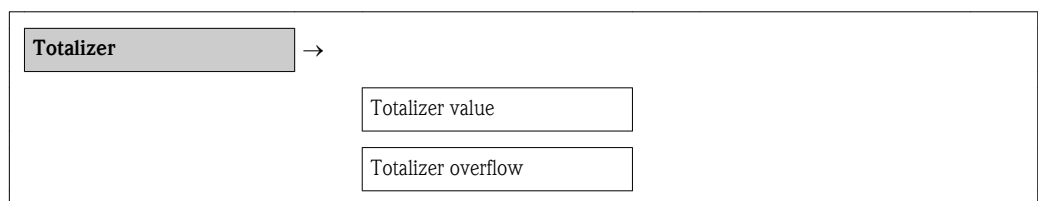

**Parameter overview with brief description**

Parameter	Prerequisite	Description	Display
-----------	--------------	-------------	---------

Totalizer value	One of the following options is selected in the <b>Assign process variable</b> parameter of the <b>Totalizer</b> submenu: <ul style="list-style-type: none"> <li>■ Mass flow</li> <li>■ Corrected volume flow</li> <li>■ FAD volume flow</li> </ul>	Displays the current totalizer counter value.	Floating-point number with sign
Totalizer overflow	One of the following options is selected in the <b>Assign process variable</b> parameter of the <b>Totalizer</b> submenu: <ul style="list-style-type: none"> <li>■ Mass flow</li> <li>■ Corrected volume flow</li> <li>■ FAD volume flow</li> </ul>	Displays the number of totalizer overflows. Value range:0 to 32.000	Integer

### 11.3.3 Output values

The **Output values** submenu contains all the parameters needed to display the current measured values for every output.

#### Navigation path

"Diagnostics" menu → Measured values → Output values

#### Structure of the submenu

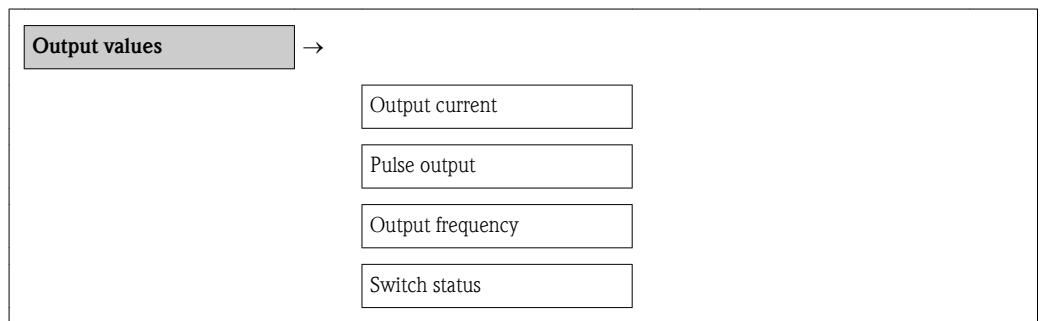



#### Parameter overview with brief description

Parameter	Prerequisite	Description	Display
Output current	-	Displays the current current value of the current output.	3.6 to 22.5 mA
Pulse output	<b>Pulse</b> must be selected as the operating mode.	Displays the current value of the pulse output.	Positive floating-point number
Output frequency	<b>Frequency</b> must be selected as the operating mode.	Displays the current value of the frequency output.	0.0 to 1 000 Hz (Up to 1 250 Hz in the error mode)
Switch status	<b>Switch</b> must be selected as the operating mode.	Displays the current switch output status.	<ul style="list-style-type: none"> <li>■ Open</li> <li>■ Closed</li> </ul>

## 11.4 Adapting the measuring device to the process conditions

The following are available for this purpose:

- Basic settings using the **Setup** (→  49) menu
- Advanced settings using the **Advanced setup** (→  55) menu

## 11.5 Performing a totalizer reset

In the **Operation** submenu, 2 parameters with various options for resetting the totalizers are available:

- Control totalizer
- Preset value
- Resetting the totalizer

### Navigation path

"Display/operat." menu → Operation

#### Function scope of the "Control totalizer" parameter

Options	Description
Reset + hold	The totaling process is stopped and the totalizer is reset to 0.
Preset + hold	The totaling process is stopped and the totalizer is set to the defined start value in the <b>Preset</b> parameter.
Reset + totalize	The totalizer is reset to 0 and the totaling process is restarted.
Preset + totalize	The totalizer is set to the defined start value in the <b>Preset</b> parameter and the totaling process is restarted.

#### Function scope of the "Reset totalizer" parameter

Options	Description
Reset + totalize	Resets the totalizer to 0 and restarts the totaling process. This deletes all the flow values previously totalized.

#### "Operation" submenu

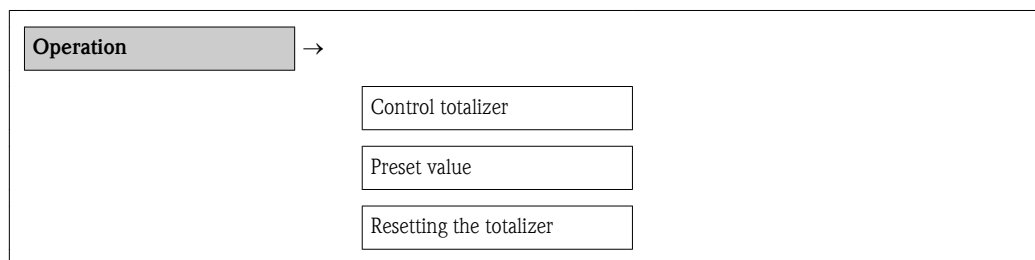

#### Parameter overview with brief description

Parameter	Prerequisite	Description	Selection/ User entry	Factory setting
Control totalizer		Control totalizer value.	<ul style="list-style-type: none"> <li>■ Totalize</li> <li>■ Reset + hold</li> <li>■ Preset + hold</li> <li>■ Reset + totalize</li> <li>■ Preset + totalize</li> </ul>	Totalize
Preset value		Specify start value for totalizer.	Floating-point number with sign	0



Reset all totalizers	-	Reset the totalizer to 0 and start.	<ul style="list-style-type: none"> <li>■ Cancel</li> <li>■ Reset + totalize</li> </ul>	Cancel
----------------------	---	-------------------------------------	--	--------

## 11.6 Showing data logging

In the device, the extended function of the HistoROM must be enabled (order option) so that the **Data logging** submenu appears. This contains all the parameters for the measured value history.

### Navigation path

Diagnostics → Data logging

"Data logging" submenu

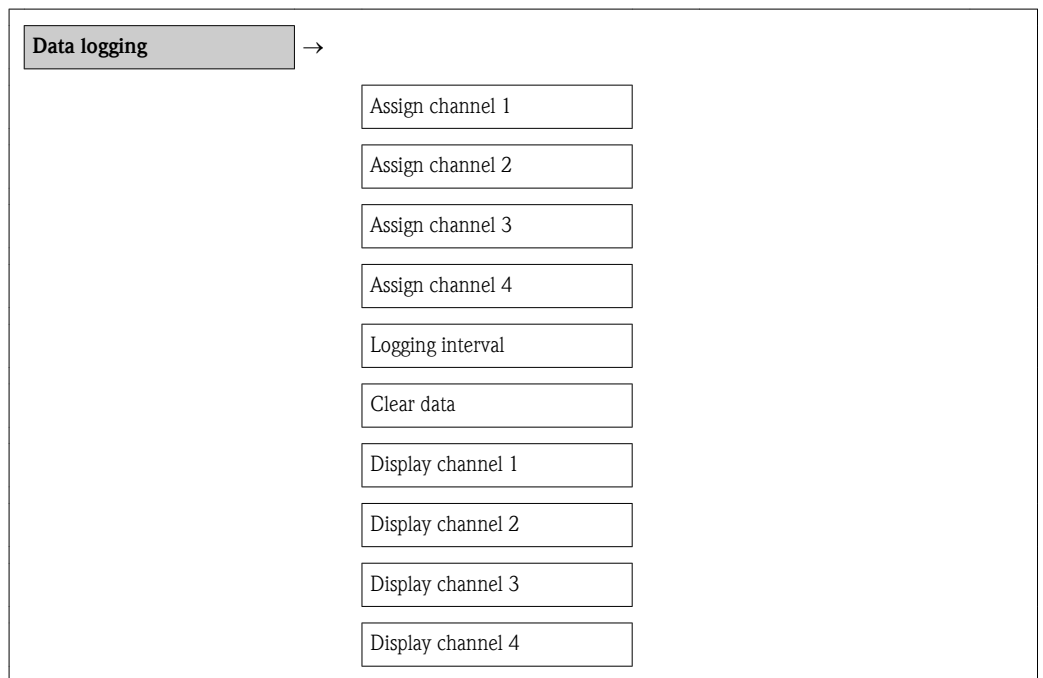

### Function range

- A total of 1000 measured values can be stored
- 4 logging channels
- Adjustable logging interval for data logging
- Display of the measured value trend for each logging channel in the form of a chart

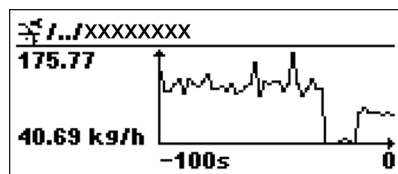

4 Chart of a measured value trend

A0013850

- x-axis: depending on the number of channels selected displays 250 to 1000 measured values of a process variable.
- y-axis: displays the approximate measured value span and constantly adapts this to the ongoing measurement.

**i** If the length of the logging interval or the assignment of the process variables to the channels is changed, the content of the data logging is deleted.

## 12 Diagnostics and troubleshooting

### 12.1 General troubleshooting

Problem	Possible cause	Remedy
Local display dark and no signal output at current output (0 mA)	Supply voltage does not match that specified on the nameplate.	Apply the correct supply voltage (→ 23).
Local display dark and no signal output at current output (0 mA)	Supply voltage has incorrect polarity.	Reverse polarity of supply voltage.
Local display dark and no signal output at current output (0 mA)	No contact between connecting cables and terminals.	Check the connection of the cables and correct if necessary.
Local display dark and no signal output at current output (0 mA)	Terminals are not plugged into the electronics module correctly.	Check terminals.
Local display dark and no signal output at current output (0 mA)	Electronics module is defective.	Order spare part (→ 93).
Local display is dark, but signal output is within the valid current range (3.6 to 22 mA)	Display is set too bright or too dark.	<ul style="list-style-type: none"> <li>■ Set the display brighter by simultaneously pressing <math>\square + \square</math>.</li> <li>■ Set the display darker by simultaneously pressing <math>\square + \square</math>.</li> </ul>
Local display is dark, but signal output is within the valid current range (3.6 to 22 mA)	Ribbon cable of the display module is not plugged in correctly.	Insert the plug correctly into the main electronics module and display module.
Local display is dark, but signal output is within the valid current range (3.6 to 22 mA)	Display module is defective.	Order spare part (→ 93).
Signal output outside the valid current range (< 3.6 mA or > 22 mA)	Main electronics module is defective.	Order spare part (→ 93).
Device shows correct value on local display, but signal output is incorrect, though in the valid current range.	Configuration error	Check and correct parameter configuration.
Device measures incorrectly.	Configuration error or device is operated outside the application.	<ol style="list-style-type: none"> <li>1. Check and correct parameter configuration.</li> <li>2. Observe limit values specified in the "Technical Data".</li> </ol>
Text on measured value display and in navigation view appears in a foreign language and cannot be understood.	Incorrect operating language is configured.	<ol style="list-style-type: none"> <li>1. Press <math>\square + \square</math> for 2 s ("home position").</li> <li>2. Press <math>\square</math>.</li> <li>3. Set the desired language in the <b>Language</b> parameter.</li> </ol>
No connection via HART protocol	Missing or incorrectly installed communication resistor.	Install the communication resistor (250 $\Omega$ ) correctly. Observe the maximum load (→ 23).
No connection via HART protocol	Commubox <ul style="list-style-type: none"> <li>■ Connected incorrectly</li> <li>■ Configured incorrectly</li> <li>■ Drivers not installed correctly</li> <li>■ USB or COM interface on computer configured incorrectly</li> </ul>	Observe the documentation for the Commubox. <ul style="list-style-type: none"> <li>■ FXA 191 HART: Document "Technical Information" TI00237F</li> <li>■ FXA 195 HART: Document "Technical Information" TI00404F</li> </ul>

<p>No connection via service interface (CDI)</p>	<p>Incorrect configuration of USB interface on PC or driver not installed correctly.</p>	<p>Observe the documentation for the Commubox.   FXA 291 HART: Document "Technical Information" TI00405C</p>
--	--	---

## 12.2 Diagnostic information on local display

### 12.2.1 Diagnostic message

Faults detected by the self-monitoring system of the measuring device are displayed as a diagnostic message in alternation with the operational display.

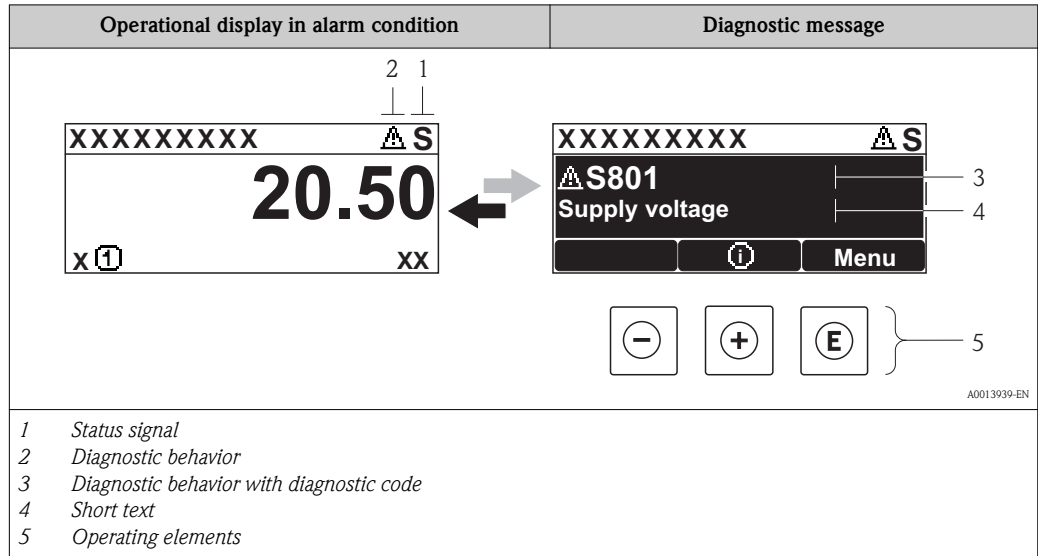

#### Status signals

Symbol	Meaning
<b>F</b> <small>A0013956</small>	<b>Failure</b> A device error has occurred. The measured value is no longer valid.
<b>C</b> <small>A0013959</small>	<b>Function check</b> The device is in service mode (e.g. during a simulation).
<b>S</b> <small>A0013958</small>	<b>Out of specification</b> The device is being operated: <ul style="list-style-type: none"> <li>■ Outside its technical specification limits (e.g. outside the process temperature range)</li> <li>■ Outside of the configuration carried out by the user (e.g. maximum flow in parameter <b>20 mA value</b>)</li> </ul>
<b>M</b> <small>A0013957</small>	<b>Maintenance required</b> Maintenance is required. The measured value is still valid.

**i** The status signals are categorized according to VDI/VDE 2650 and NAMUR Recommendation NE 107: F = Failure, C = Function Check, S = Out of Specification, M = Maintenance Required

#### Diagnostic behavior

Symbol	Meaning
 <small>A0013961</small>	<b>Alarm</b> Measurement is interrupted. The signal outputs and totalizers assume the defined alarm condition. A diagnostic message is generated.
 <small>A0013962</small>	<b>Warning</b> Measurement is resumed. The signal outputs and totalizers are not affected. A diagnostic message is generated.

### Diagnostic information

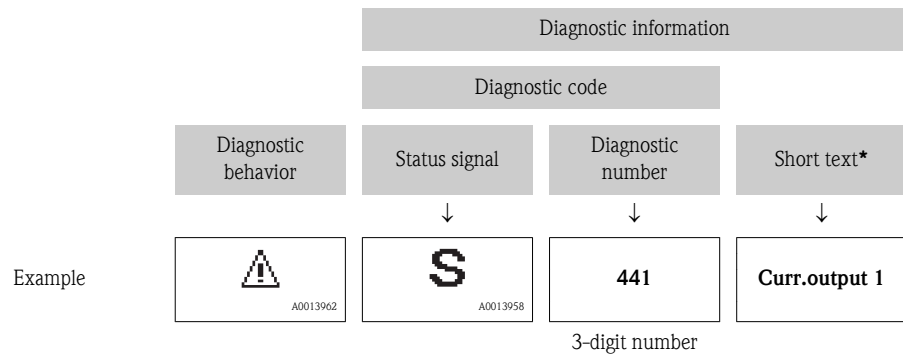

The fault can be identified using the diagnostic information. The short text helps you by providing information about the fault. In addition, the corresponding symbol for the diagnostic behavior is displayed in front of the diagnostic information.



If two or more diagnostic events are pending simultaneously, only the message with the highest priority is shown. Other diagnostic messages that are pending can be viewed in the **Diagnostic list** submenu (→  82).

 Past diagnostic messages that are no longer pending are shown in the **Event logbook** submenu (→  82).

### Operating elements

Key	Meaning
 A0013970	<p><b>Plus key</b></p> <p><i>In a menu, submenu</i></p> <p>Opens the message about the remedy information.</p>
 A0013952	<p><b>Enter key</b></p> <p><i>In a menu, submenu</i></p> <p>Opens the operating menu.</p>

### 12.2.2 Calling up remedial measures

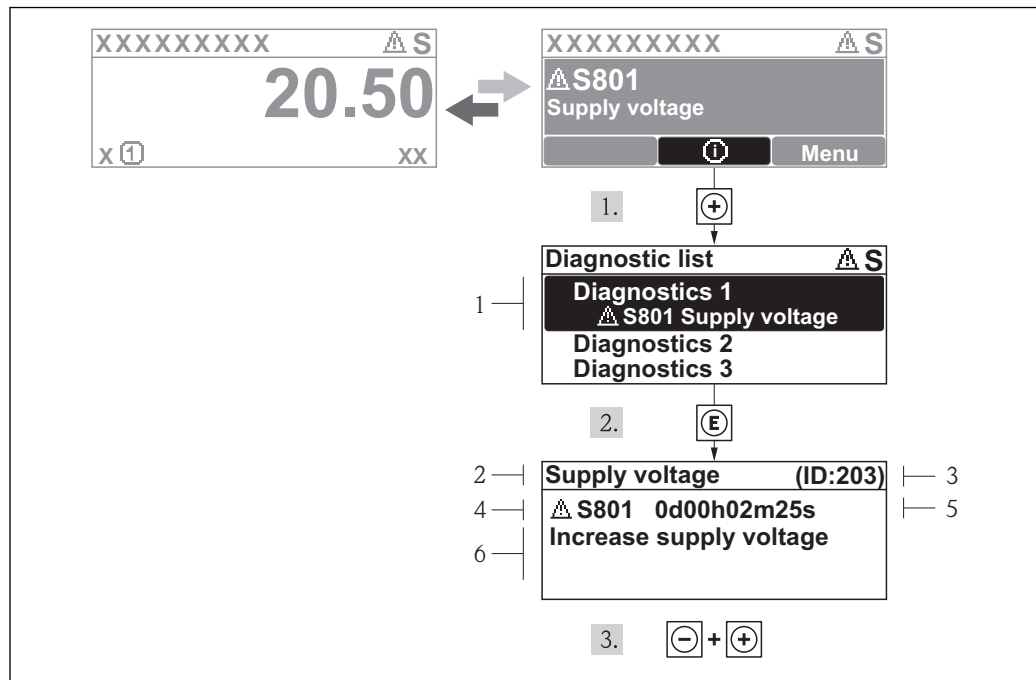

5 Message for remedial measures

- 1 Short text
- 2 Diagnostic behavior with diagnostic code
- 3 Service ID
- 4 Operation time of occurrence
- 5 Remedial measures

The user is in the diagnostic message.

1. Press  $\oplus$  ( $\oplus$  symbol).
  - ✓ The **Diagnostic list** submenu opens.
2. Select the desired diagnostic event with  $\oplus$  or  $\ominus$  and press  $\oplus$ .
  - ✓ The message for the remedial measures for the selected diagnostic event opens.
3. Press  $\ominus$  +  $\oplus$  simultaneously.
  - ✓ The message about the remedial measures closes.

The user is in the **Diagnostics** menu at an entry for a diagnostics event, e.g. in the **Diagnostic list** submenu or the **Previous diagnostics** parameter.

1. Press  $\oplus$ .
  - ✓ The message for the remedial measures for the selected diagnostic event opens.
2. Press  $\ominus$  +  $\oplus$  simultaneously.
  - ✓ The message about the remedial measures closes.

## 12.3 Diagnostic information in the operating tool

If diagnostic information is present in the operating tool, the status signal appears in the top left status area along with the corresponding symbol in accordance with VDI/VDE 2650 and NAMUR Recommendation NE 107:

- Failure (F)
- Function check (C)
- Out of specification (S)
- Maintenance required (M)

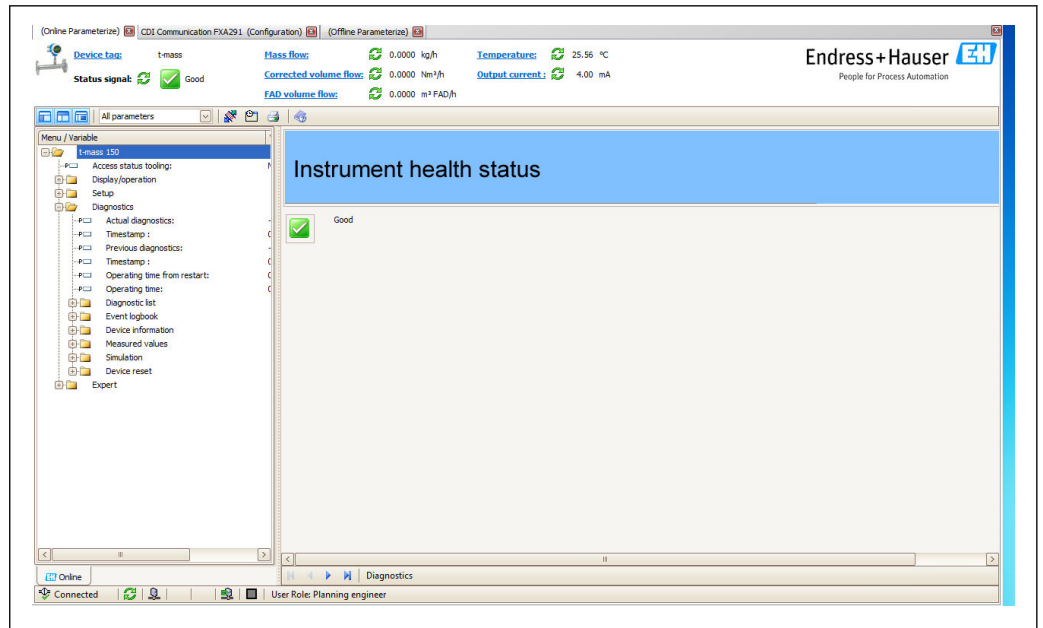

A0017300-EN

### Calling up remedy information

1. Navigate to the "Diagnostics" menu.
  - ✓ In the "Actual diagnostics" parameter, the diagnostic code is shown with a short text.
2. On the right in the display range, hover the cursor over the "Actual diagnostics" parameter.
  - ✓ A tool tip with remedial measures for the diagnostic number appears.

## 12.4 Adapting the diagnostic information

### 12.4.1 Adapting the diagnostic behavior

Each diagnostic number is assigned a specific diagnostic behavior at the factory. The user can change this assignment for specific diagnostic numbers via the **Diagnostics No. xxx** parameter.

#### Navigation path

"Expert" menu → System → Diagnostic handling → Diagnostic behavior → Assign behavior of diagnostic no. xxx

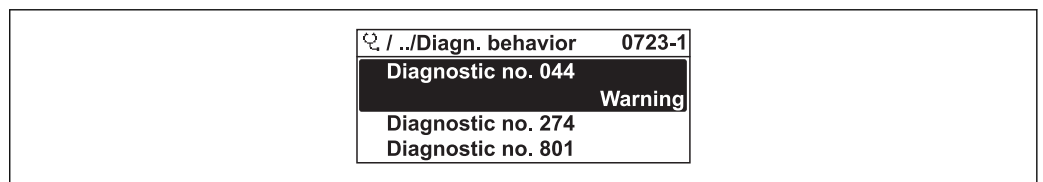

A0014048-EN

You can assign the following options to the diagnostic number as the diagnostic behavior:

Options	Description
Alarm	Measurement is interrupted. The signal outputs assume the defined alarm condition. A diagnostic message is generated.
Warning	The device continues to measure. A diagnostic message is generated.
Logbook entry only	The device continues to measure. The diagnostic message is entered in the Event logbook (events list) submenu only and is not displayed in alternation with the measured value display.
Off	The diagnostic event is ignored, and no diagnostic message is generated or entered.

## 12.5 Overview of diagnostic information

Diagnostic number	Short text	Remedy information	Status signal from the factory	Diagnostic behavior from the factory
<b>Diagnostics for the sensor</b>				
004	Sensor	Change sensor	F	Alarm*
082	Data storage	1. Change main electronic module. 2. Change sensor.	F	Alarm*
083	Memory content	1. Restart device. 2. Restore data. 3. Change sensor.	F	Alarm*

Diagnostic number	Short text	Remedy information	Status signal from the factory	Diagnostic behavior from the factory
<b>Diagnostics for the electronics</b>				
270	Main electronic failure	Change main electronic module.	F	Alarm
271	Main electronic failure	1. Restart device. 2. Change main electronic module.	F	Alarm
272	Main electronic failure	1. Restart device. 2. Contact service.	F	Alarm*
273	Main electronic failure	1. Emergency operation via display. 2. Change main electronics.	F	Alarm*
282	Data storage	1. Restart device. 2. Contact service.	F	Alarm
283	Memory content	1. Transfer data or reset device. 2. Contact service.	F	Alarm*
311	Electronic failure	1. Transfer data or reset device. 2. Contact service.	F	Alarm*
311	Electronic failure	Maintenance required! 1. Do not perform reset. 2. Contact service.	M	Warning

\* Diagnostic behavior can be changed: Section 12.4 "Adapting the diagnostic behavior"

Diagnostic number	Short text	Remedy information	Status signal from the factory	Diagnostic behavior from the factory
<b>Diagnostics for the configuration</b>				
410	Data transfer	1. Check connection. 2. Retry data transfer.	F	Alarm*
411	Upload/download	1. Check connection. 2. Retry data transfer.	F	Alarm*
411	Up-/download active	Up-/download active, please wait	C	Warning*



431	Trim	Carry out trim.	C	Warning*
437	Incompatible configuration	1. Restart device. 2. Contact service.	F	Alarm*
437	Incompatible configuration	1. Transfer data or reset device. 2. Contact service.	C	Alarm
438	Dataset	1. Check data set file. 2. Check device configuration. 3. Up- and download new configuration.	M	Warning*
441	Current output	1. Check process. 2. Check current output settings.	S	Warning*
442	Frequency output	1. Check process. 2. Check frequency output setting.	S	Warning*
443	Pulse output	1. Check process. 2. Check pulse output setting.	S	Warning*
453	Flow override	Deactivate flow override.	C	Warning*
484	Simulation failsafe mode	Deactivate simulation.	C	Alarm
485	Simulation process variable	Deactivate simulation.	C	Warning*
491	Simulation current output	Deactivate simulation.	C	Warning*
492	Frequency simulation	Deactivate simulation.	C	Warning*
493	Simulation pulse output	Deactivate simulation.	C	Warning
494	Switch output simulation	Deactivate simulation.	C	Warning

\* Diagnostic behavior can be changed: Section 12.4 "Adapting the diagnostic behavior"

Diagnostic number	Short text	Remedy information	Status signal from the factory	Diagnostic behavior from the factory
<b>Diagnostics for the process</b>				
832	Ambient temperature	Reduce ambient temperature.	S	Warning*
833	Ambient temperature	Increase ambient temperature.	S	Warning*
834	Process temperature	Reduce process temperature.	S	Warning*
835	Process temperature	Increase process temperature.	S	Warning*
841	Flow velocity	1. Check process conditions. 2. Increase system pressure	S	Alarm
842	Process limit	Low flow cut off active! Check low flow cut off configuration.	S	Logbook entry only
861	Temperature differential	1. Check process conditions. 2. Check signal path.	S	Alarm

\* Diagnostic behavior can be changed: Section 12.4 "Adapting the diagnostic behavior"

## 12.6 Resetting the measuring device

Using the **Device reset** parameter it is possible to reset the entire device configuration or some of the configuration to a defined state.

### Navigation path

"Diagnostics" menu → Device reset → Device reset

*Function scope of the "Device reset" parameter*

Options	Description
Cancel	The user can exit the parameter. No action is performed.
To factory defaults	Every parameter is reset to the factory setting.
To delivery settings	Every parameter for which a customer-specific default setting was ordered is reset to this customer-specific value. All other parameters are reset to the factory setting.  This option is not visible if no customer-specific settings have been ordered.
Restart device	The restart resets every parameter whose data are in the volatile memory (RAM) to the factory setting (e.g. measured value data). The device configuration remains unchanged.

## 12.7 Diagnostics list

In the **Diagnostic list** submenu, up to 5 currently pending diagnostic messages can be displayed. If more than 5 messages are pending, the messages with the highest priority are shown on the display.

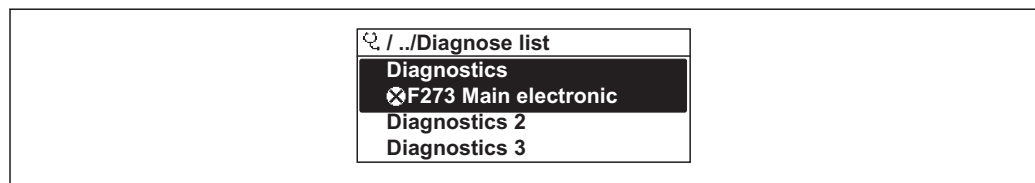

### Navigation path

"Diagnostics" menu → Diagnostic list



A0014006-EN

### Calling up and closing remedial measures

1. Press .
  - ✓ The message for the remedial measures for the selected diagnostic number opens.
2. Press  +  simultaneously.
  - ✓ The message about the remedy information closes.

 For the structure of the remedial measure message (→  84)

## 12.8 Event logbook

### 12.8.1 Event history

A chronological overview of the event messages that have occurred is provided in the **Events list** submenu.

### Navigation path

"Diagnostics" menu → Event logbook → Events list

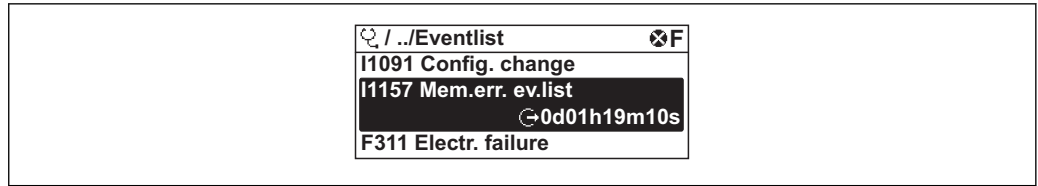

A0014008-EN

A maximum of 20 event messages can be displayed in chronological order. If the advanced HistoROM function is enabled in the device (order option), up to 1000 entries can be displayed.

The event history includes entries for:

- Diagnostic events (→ 82)
- Information events (→ 82)

In addition to the operation time of its occurrence, each event is also assigned a symbol that indicates whether the event has occurred or is ended:

- Diagnostics event
  - : Event has occurred
  - : Event has ended
- Information event
  - : Event has occurred

### Calling up and closing remedial measures

1. Press .
    - ✓ The message for the remedial measures for the selected diagnostic number opens.
  2. Press + simultaneously.
    - ✓ The message about the remedy information closes.
- For the structure of the remedial measure message (→ 84)
- For filtering the displayed event messages (→ 90)

### 12.8.2 Filtering the event logbook

Using the **Filter options** parameter, you can define which category of event messages is displayed in the **Events list** submenu.

#### Navigation path

"Diagnostics" menu → Event logbook → Filter options

#### Filter categories

- All
- Failure (F)
- Function check (C)
- Out of specification (S)
- Maintenance required (M)
- Information (I)

### 12.8.3 Overview of information events

Unlike a diagnostic event, an information event is displayed in the event logbook only and not in the diagnostic list.

Information event	Event text
I1000	—— (device ok)
I1089	Power on

I1090	Configuration reset
I1091	Configuration changed
I1092	Trend data deleted
I1110	Write protection switch changed
I1151	History reset
I1155	Reset electronic temperature
I1156	Memory error trend
I1157	Memory error event list
I1185	Display backup done
I1186	Restore via display done
I1187	Settings downloaded with display
I1188	Display data cleared
I1189	Backup compared
I335	Firmware changed

## 13 Repair

### 13.1 General notes

#### Repair and conversion concept

The Endress+Hauser repair and conversion concept provides for the following:

- The measuring devices have a modular design.
- Spare parts are grouped into logical kits with the associated Installation Instructions.
- Repairs are carried out by Endress+Hauser Service or by correspondingly trained customers.
- Certified devices can be converted into other certified devices only by Endress+Hauser Service or at the factory.

#### Notes for repair and conversion

For repair and modification of a measuring device, observe the following notes:

- Use only original Endress+Hauser spare parts.
- Carry out the repair according to the Installation Instructions.
- Observe the applicable standards, federal/national regulations, Ex documentation (XA) and certificates.
- Document every repair and each conversion and enter them into the *W@M* life cycle management database.

### 13.2 Spare parts

- Some interchangeable measuring device components are identified by an overview sign. This contains information about the spare part.
- The spare part overview sign is located in the connection compartment cover of the device and contains the following information:
  - A list of the most important spare parts for the measuring device, including their ordering information.
  - The URL for the *W@M Device Viewer* ([www.endress.com/deviceviewer](http://www.endress.com/deviceviewer)):  
All the spare parts for the measuring device, along with the order code, are listed here and can be ordered. If available, users can also download the associated Installation Instructions.



Measuring device serial number:

- Is located on the device nameplate and the spare part overview sign.
- Can be read out via the "Serial number" parameter in the "Device information" submenu.

### 13.3 Endress+Hauser services



For information about service and spare parts, contact your Endress+Hauser distributor.

## 14 Maintenance

### 14.1 Maintenance tasks

No special maintenance work is required.

#### 14.1.1 Exterior cleaning

When cleaning the exterior of measuring devices, always use cleaning agents that do not attack the surface of the housing or the seals.

#### 14.1.2 Interior cleaning

##### Cleaning the transducer

In applications with dirty gases, it is advisable to inspect and clean the device regularly to minimize measured errors caused by fouling or buildup.



The inspection and cleaning intervals depend on experience and the field of application.

##### NOTICE

**The use of unsuitable equipment or cleaning liquids can damage the transducer.**

- ▶ Do not use pigs to clean the pipe.
- ▶ Use an oil-free cleaning agent that does not form a film to clean the sensor. Gently clean the surface using a soft brush.
- ▶ When cleaning make sure that the transducers are not damaged.
- ▶ Never use cleaning agents that can corrode the material and the seal.

Sensor-specific information:

- Follow the safety instructions when removing the sensor (→  8).
- Follow the instructions in the "Installation" section when removing the sensor (→  20).

### 14.2 Measuring and test equipment

Endress+Hauser offers a wide variety of measuring and test equipment, such as W@M or device tests.

 Your Endress+Hauser representative can provide detailed information on the services.

 For a list of some of the measuring and test equipment, refer to the "Accessories" chapter of the "Technical Information" document for the device.

### 14.3 Endress+Hauser services

Endress+Hauser offers a wide variety of services for maintenance such as recalibration, maintenance service or device tests.

 Your Endress+Hauser representative can provide detailed information on the services.

## 15 Return

Observe the following points for returning the device:

- Contact your Endress+Hauser Sales Center to obtain information about the procedure and basic conditions.
- Enclose the completed "Decontamination declaration" form with the device.



The form is available:

As a photocopy master at the end of this manual

## 16 Disposal

### 16.1 Removing the measuring device

1. Switch off the device.
2. **WARNING!** Danger to persons from process conditions. Beware of hazardous process conditions such as pressure in the measuring device, high temperatures or aggressive fluids. Carry out the mounting and connection steps from the chapters "Mounting the measuring device" and "Connecting the measuring device" in the logically reverse sequence. Observe the safety instructions.

### 16.2 Disposing of the measuring device

**⚠ WARNING**

**Danger to personnel and environment from fluids that are hazardous to health.**

- ▶ Ensure that the measuring device and all cavities are free of fluid residues that are hazardous to health or the environment, e.g. substances that have permeated into crevices or diffused through plastic.

Observe the following notes during disposal:

- Observe valid local site rules and federal/national regulations.
- Ensure proper separation and reuse of the device components.



## 17 Technical data

### 17.1 Application

The measuring device is suitable for flow measurement of gases only.

To ensure that the device remains in proper operating condition for its service life, use the measuring device only for media against which the process-wetted materials are adequately resistant.

### 17.2 Function and system design

Measuring principle

Mass flow measurement based on thermal measuring principle

Measuring system

The device consists of a transmitter and a sensor.

One device version is available: compact version – transmitter and sensor form a mechanical unit. For information on the structure of the device (→  10)

### 17.3 Characteristic values

Measured variable

#### Direct measured variables

- Mass flow
- Gas temperature

#### Calculated measured variables

- Corrected volume flow
- FAD (free air delivery) volume flow

Measuring range

The available measuring range depends on the choice of gas and the size of the pipe. The measuring device is calibrated individually with air (under ambient conditions) and the value is converted in order to adapt it to the customer's gas if necessary.

 To obtain information on other gases and process conditions, please contact your Endress +Hauser sales office.

The following tables list the ranges available for air.

#### Measuring range "Calibration flow", option G and H

Specified measuring range up to 100% (→  104)

*SI units for insertion version*

DN	[kg/h]		[Nm <sup>3</sup> /h] at 0 °C (1.013 bar a)		[Nm <sup>3</sup> /h at 15 °C (1.013 bar a)	
	min.	Max.	min.	Max.	min.	Max.
80	20	2030	16	1570	17	1660
100	38	3750	29	2900	31	3070
150	75	7500	58	5800	61	6130
200	125	12500	97	9700	102	10200
250	200	20000	155	15500	164	16400

DN	[kg/h]		[Nm <sup>3</sup> /h] at 0 °C (1.013 bar a)		[Nm <sup>3</sup> /h at 15 °C (1.013 bar a)	
	[mm]	min.	Max.	min.	Max.	min.
300	280	28 000	217	21 700	229	22 900
400	500	50 000	387	38 700	409	40 900
500	800	80 000	620	62 000	655	65 500
600	1 150	115 000	890	89 000	941	94 100
700	1 590	159 000	1 230	123 000	1 300	130 000
1 000	3 200	320 000	2 480	248 000	2 620	262 000
1 500	7 200	720 000	5 568	556 800	5 886	588 600

*US units for insertion version*

DN	[lb/h]		[Scf/min] at 32 °F (14.7 psi a)		[Scf/min] at 59 °F (14.7 psi a)	
	[in]	min.	Max.	min.	Max.	min.
3	45	4 476	9	924	10	977
4	83	8 269	17	1 710	18	1 810
6	165	16 540	34	3 420	36	3 610
8	276	27 560	57	5 680	60	6 000
10	441	44 100	91	9 130	97	9 650
12	617	61 740	128	12 800	135	13 500
16	1 103	110 300	228	22 800	241	24 100
20	1 764	176 400	365	36 500	386	38 600
24	2 536	253 600	524	52 400	554	55 400
28	3 506	350 600	724	72 400	765	76 500
40	7 056	705 600	1 460	146 000	1 542	154 200
60	15 876	1 587 600	3 280	328 000	3 465	346 500

**Measuring range "Calibration flow" option K**

Specified measuring range up to 150% (→  104)

*SI units for insertion version*

DN	[kg/h]		[Nm <sup>3</sup> /h] at 0 °C (1.013 bar a)		[Nm <sup>3</sup> /h at 15 °C (1.013 bar a)	
	[mm]	min.	Max.	min.	Max.	min.
80	20	3 045	16	2 355	17	2 490
100	38	5 625	29	4 350	31	4 605
150	75	11 250	58	8 700	61	9 195
200	125	18 750	97	14 550	102	15 300
250	200	30 000	155	23 250	164	24 600
300	280	42 000	217	32 550	229	34 350
400	500	75 000	387	58 050	409	61 350
500	800	120 000	620	93 000	655	98 250
600	1 150	172 500	890	133 500	941	141 150
700	1 590	238 500	1 230	184 500	1 300	195 000

DN	[kg/h]		[Nm <sup>3</sup> /h] at 0 °C (1.013 bar a)		[Nm <sup>3</sup> /h] at 15 °C (1.013 bar a)	
	[mm]	min.	Max.	min.	Max.	min.
1 000	3 200	480 000	2 480	372 000	2 620	393 000
1 500	7 200	1 080 000	5 568	835 200	5 886	882 900

*US units for insertion version*

DN	[lb/h]		[Scf/min] at 32 °F (14.7 psi a)		[Scf/min] at 59 °F (14.7 psi a)	
	[in]	min.	Max.	min.	Max.	min.
3	45	6 714	9	1 386	10	1 466
4	83	12 403.5	17	2 565	18	2 715
6	165	24 807	34	5 130	36	5 415
8	276	41 344.5	57	8 520	60	9 000
10	441	66 150	91	13 695	97	14 475
12	617	92 610	128	19 200	135	20 250
16	1 103	165 375	228	34 200	241	36 150
20	1 764	264 600	365	54 750	386	57 900
24	2 536	380 362.5	524	78 600	554	81 300
28	3 506	525 892.5	724	108 600	765	114 750
40	7 056	1 058 400	1 460	219 000	1 542	231 300
60	15 876	2 381 400	3 280	492 000	3 465	519 750

Operable flow range

Over 100:1 (over 150:1 for calibration option code K).

Even in the extended measuring range (above the specified end value), the flow rate is captured and provided as an output signal. However, the extended range is not subject to the specified measuring uncertainty.

## 17.4 Output

Output signal

**Current output**

<b>Current output</b>	4-20 mA HART, active
<b>Maximum output values</b>	<ul style="list-style-type: none"> <li>■ DC 24 V (when idle)</li> <li>■ 22 mA</li> </ul> <p> If the option <b>Defined value</b> is selected in the <b>Failure mode</b> parameter : 22.5 mA</p>
<b>Load</b>	0 to 750 Ω
<b>Resolution</b>	16 Bit or 0.38 µA
<b>Damping</b>	Adjustable: 0 to 999 s
<b>Assignable measured variables</b>	<ul style="list-style-type: none"> <li>■ Mass flow</li> <li>■ Corrected volume flow</li> <li>■ FAD volume flow</li> <li>■ Temperature</li> </ul>

### Pulse/frequency/switch output

<b>Function</b>	Can be set to pulse, frequency or switching output
<b>Version</b>	Passive, open collector
<b>Maximum input values</b>	<ul style="list-style-type: none"> <li>■ DC30 V</li> <li>■ 25 mA</li> </ul>
<b>Voltage drop</b>	For 25 mA: ≤ DC2 V
<b>Pulse output</b>	
<b>Pulse width</b>	Adjustable: 0.5 to 2000 ms → pulse rate:0 to 1000 Pulse/s
<b>Pulse value</b>	Adjustable
<b>Assignable measured variables</b>	<ul style="list-style-type: none"> <li>■ Mass flow</li> <li>■ Corrected volume flow</li> <li>■ FAD volume flow</li> </ul>
<b>Frequency output</b>	
<b>Maximum frequency</b>	Adjustable:0 to 1000 Hz
<b>Damping</b>	Adjustable:0 to 999 s
<b>Pulse/pause ratio</b>	1:1
<b>Assignable measured variables</b>	<ul style="list-style-type: none"> <li>■ Mass flow</li> <li>■ Corrected volume flow</li> <li>■ FAD volume flow</li> <li>■ Temperature</li> </ul>
<b>Switching output</b>	
<b>Switching behavior</b>	Binary, conductive or non-conductive
<b>Switching delay</b>	Adjustable:0 to 100 s
<b>Number of switching cycles</b>	Unlimited
<b>Assignable functions</b>	<ul style="list-style-type: none"> <li>■ Off</li> <li>■ On</li> <li>■ Diagnostic behavior</li> <li>■ Limit value</li> <li>■ Status</li> </ul>

Signal on alarm

Depending on the interface, failure information is displayed as follows:

### Current output

<b>Failure mode</b>	Can be selected (as per NAMUR recommendation NE 43)
<b>Minimum alarm</b>	3.6 mA
<b>Maximum alarm</b>	22 mA
<b>Adjustable value</b>	3.6 to 22.5 mA

### Pulse/frequency/switch output

<b>Pulse output</b>	
<b>Failure mode</b>	Choose from: <ul style="list-style-type: none"> <li>■ Actual value</li> <li>■ No pulses</li> </ul>
<b>Frequency output</b>	

<b>Failure mode</b>	Choose from: <ul style="list-style-type: none"> <li>■ Actual value</li> <li>■ Defined value: 0 to 1250 Hz</li> <li>■ 0 Hz</li> </ul>
<b>Switching output</b>	
<b>Failure mode</b>	Choose from: <ul style="list-style-type: none"> <li>■ Current status</li> <li>■ Open</li> <li>■ Closed</li> </ul>

**Local display**

<b>Plain text display</b>	With information on cause and remedial measures
---------------------------	---

 Status signal as per NAMUR recommendation NE 107

**Operating tool**

- Via digital communication: HART protocol
- Via service interface

<b>Plain text display</b>	With information on cause and remedial measures
---------------------------	---

Low flow cut off                      The switch point for low flow cut off is programmable.

Galvanic isolation                    The following connections are galvanically isolated from each other:

- Outputs
- Power supply

Protocol-specific data

**HART**

Manufacturer ID	0x11
Device type ID	0x66
HART protocol revision	6.0
Device description files (DTM, DD)	Information and files under: <a href="http://www.endress.com">www.endress.com</a>
HART load	Min. 250 Ω
Dynamic variables	<p>The measured variables can be freely assigned to the dynamic variables.</p> <p><b>Measured variables for PV (primary dynamic variable)</b></p> <ul style="list-style-type: none"> <li>■ Mass flow</li> <li>■ Corrected volume flow</li> <li>■ FAD volume flow</li> <li>■ Temperature</li> </ul> <p><b>Measured variables for SV, TV, QV (secondary, tertiary and quaternary dynamic variable)</b></p> <ul style="list-style-type: none"> <li>■ Mass flow</li> <li>■ Corrected volume flow</li> <li>■ FAD volume flow</li> <li>■ Temperature</li> <li>■ Totalizer</li> </ul>

## 17.5 Power supply

Terminal assignment

**Transmitter**

*Connection version 4-20 mA HART, pulse/frequency/switching output*

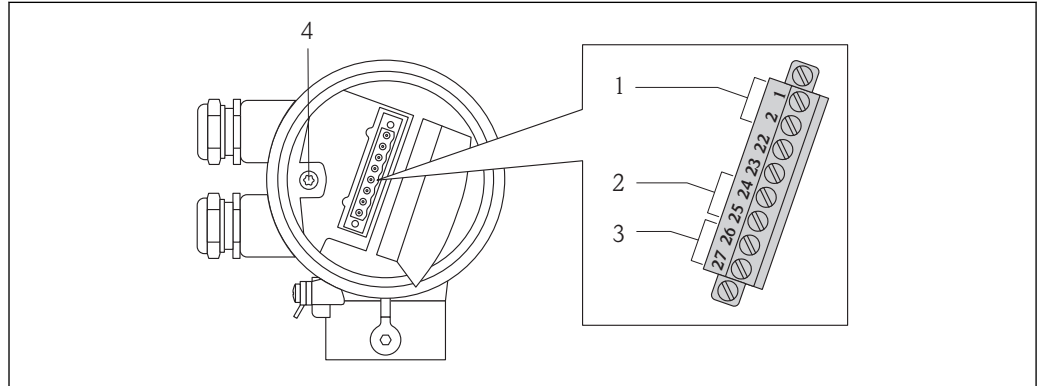

A0017178

- 1 Supply voltage
- 2 Signal transmission: Pulse/frequency/switching output
- 3 Signal transmission: 4-20 mA HART
- 4 Ground terminal for cable shield

*Supply voltage*

Order code for "Power supply"	Terminal numbers	
	1 (L+)	2 (L-)
Option <b>D</b>	DC 24 V (18 to 30 V)	

*Signal transmission*

Order code for "Output"	Terminal numbers			
	Output 1		Output 2	
	26 (+)	27 (-)	24 (+)	25 (-)
Option <b>A</b>	4-20 mA HART active		-	
Option <b>B</b>	4-20 mA HART active		Pulse/frequency/switch output	
Option <b>K</b>	-		Pulse/frequency/switch output	

**Supply voltage**

DC 24 V (18 to 30 V)

The power supply circuit must comply with SELV/PELV requirements.

Power consumption

Order code for "Output"	Maximum power consumption
<ul style="list-style-type: none"> <li>■ Option <b>A</b>: 4-20mA HART</li> <li>■ Option <b>B</b>: 4-20mA HART, pulse/frequency/switching output</li> <li>■ Option <b>K</b>: Pulse/frequency/switching output</li> </ul>	3.1 W

Current consumption	<b>Order code for "Output"</b>	<b>Maximum current consumption</b>	<b>Maximum switch-on current</b>
	<ul style="list-style-type: none"> <li>■ Option <b>A</b>: 4-20mA HART</li> <li>■ Option <b>B</b>: 4-20mA HART, pulse/frequency/switching output</li> <li>■ Option <b>K</b>: Pulse/frequency/switching output</li> </ul>	185 mA	< 2.5 A

Power supply failure	<ul style="list-style-type: none"> <li>■ Totalizers stop at the last value measured.</li> <li>■ Configuration is retained in the device memory.</li> <li>■ Error messages (incl. total operated hours) are stored.</li> </ul>
----------------------	---

### Electrical connection **Connecting the transmitter**

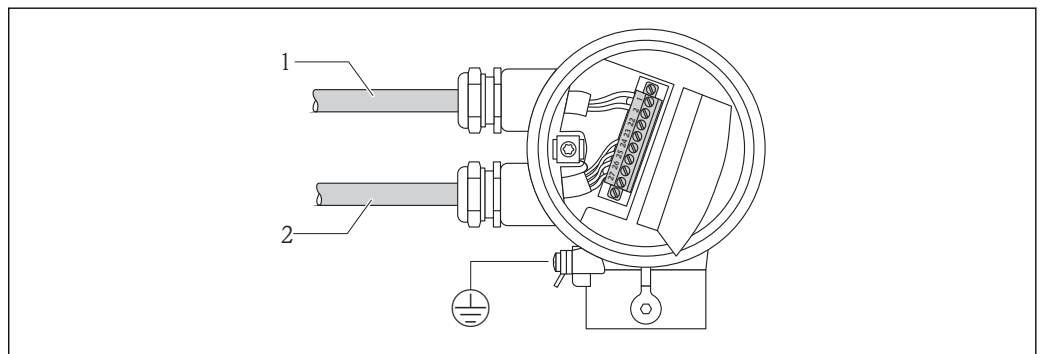

- 1 Cable entry for supply voltage  
2 Cable entry for signal transmission

A0017179

Potential equalization	No special measures for potential equalization are required.
------------------------	--

Terminals	Plug-in screw terminals for specified wire cross-sections
-----------	---

Cable entries	<ul style="list-style-type: none"> <li>■ Cable gland: M20 × 1.5 with cable Ø6 to 12 mm (0.24 to 0.47 in)</li> <li>■ Thread for cable entry: <ul style="list-style-type: none"> <li>– NPT 1/2"</li> <li>– G 1/2"</li> </ul> </li> </ul>
---------------	--

Cable specification	<b>Wire cross-sectional area</b>
	0.5 to 1.5 mm <sup>2</sup> (21 to 16 AWG)
	<b>Permitted temperature range</b>
	<ul style="list-style-type: none"> <li>■ –40 °C (–40 °F)...≥ 80 °C (176 °F)</li> <li>■ Minimum requirement: cable temperature range ≥ ambient temperature +20 K</li> </ul>

#### Signal cable

##### *Current output*

For 4-20 mA HART: Shielded cable recommended. Observe grounding concept of the plant.

##### *Pulse/frequency/switch output*

Standard installation cable is sufficient.

**Supply voltage cable**

Standard installation cable is sufficient.

**17.6 Performance characteristics**

Reference operating conditions

- Calibration systems traceable to national standards
- Accredited in accordance with ISO/IEC 17025
- Air controlled to 24 °C ± 0.5 °C (75.2 °F ± 0.9 °F) at atmospheric pressure
- Humidity controlled < 40 % RH

Maximum measured error

o.r. = of reading; o.f.s. = of full scale value

- The full scale value depends upon the nominal diameter of the measuring device and the max. flow of the calibration rig.
- Full scale values of the specified measuring range.(→ 97)

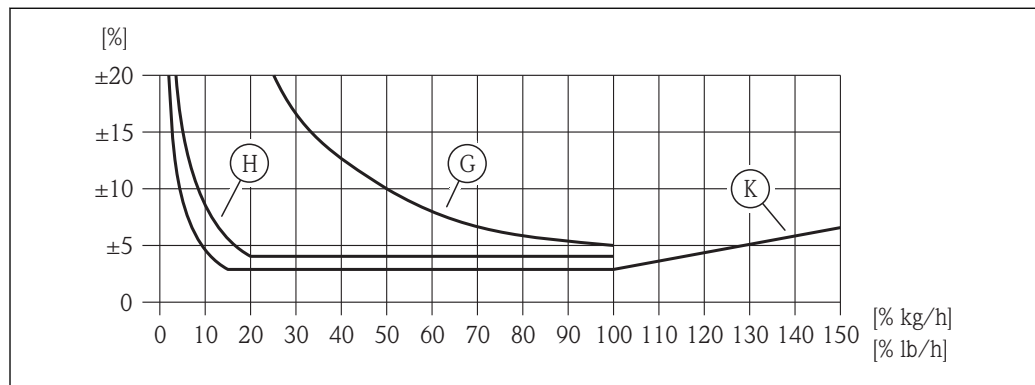

6 Maximum measured error (% mass flow) as % of measured value/full scale value. G, H, K: Order code options for "Calibration flow", see the following table

Order code option for "Calibration flow"	Accuracy	Description
K	<ul style="list-style-type: none"> <li>■ Q = 100 to 150 %: from ±3 % to ±6.5 % of the current measured value increasing linearly as expressed in the following equation: <math>\pm 3 \pm (X_n - 100) \times 0.07 [\% \text{ o.r.}]</math> (100 % &lt; <math>X_n \leq 150</math> %; <math>X_n</math> = current flow as a % o.f.s. )</li> <li>■ Q = 15 to 100 %: ±3 % of current measured value</li> <li>■ Q = 1 to 15 % ±0.45 % o.f.s.</li> </ul> (all data under reference conditions)	The measuring device is calibrated and adjusted on an accredited and traceable calibration rig . The accuracy is certified with a calibration protocol.
H	<ul style="list-style-type: none"> <li>■ Q = 20 to 100 % ±4 % of current measured value</li> <li>■ Q = 1 to 20 % ±0.8 % o.f.s.</li> </ul> (all data under reference conditions)	The measuring performance of the device is tested, and a verification protocol confirms that the device measures within the specified tolerance.
G	Q = 1 to 100 % ±5 % o.f.s. (under reference conditions)	This version is subject to neither a calibration nor a verification of measuring performance.



**Accuracy of outputs***Current output*

<b>Accuracy</b>	Max. $\pm 0.05$ % o.f.s. or $\pm 10$ $\mu\text{A}$
-----------------	--

Repeatability  $\pm 0.5$  % of value for velocities  $> 1.0$  m/s (3.3 ft/s)

Response time Typically  $< 3$  s for 63 % of a given step change (in both directions)

Influence of medium pressure Air: 0.35 % of value per bar (0.02 % per psi) of process pressure change

**17.7 Installation**

"Mounting requirements" ( $\rightarrow$   15)

**17.8 Environment**

Ambient temperature range	<b>Measuring device</b>	$-40$ to $+60$ $^{\circ}\text{C}$ ( $-40$ to $+140$ $^{\circ}\text{F}$ )
	<b>Local display</b>	$-20$ to $+60$ $^{\circ}\text{C}$ ( $-4$ to $+140$ $^{\circ}\text{F}$ ), the readability of the display may be impaired at temperatures outside the temperature range.

-  If operating outdoors:  
Avoid direct sunlight, particularly in warm climatic regions.

Storage temperature  $-40$  to  $+80$   $^{\circ}\text{C}$  ( $-40$  to  $+176$   $^{\circ}\text{F}$ ), preferably at  $+20$   $^{\circ}\text{C}$  ( $+68$   $^{\circ}\text{F}$ )

Degree of protection **Transmitter**

- As standard: IP66/67, type 4X enclosure
- When housing is open: IP20, type 1 enclosure
- Display module: IP20, type 1 enclosure

**Sensor**  
IP66/67, type 4X enclosure

Shock resistance As per IEC/EN 60068-2-31

Vibration resistance Acceleration up to 2 g, 10 to 150 Hz, as per IEC/EN 60068-2-6

Electromagnetic compatibility (EMC) As per IEC/EN 61326 and NAMUR Recommendation 21 (NE 21).

 Details are provided in the Declaration of Conformity.

## 17.9 Process

Medium temperature range	<p><b>Sensor</b> -40 to +100 °C (-40 to +212 °F)</p> <p><b>Seals (G thread only)</b></p> <ul style="list-style-type: none"> <li>■ HNBR: -40 to +100 °C (-40 to +212 °F)</li> <li>■ EPDM: -35 to +100 °C (-31 to +212 °F)</li> </ul> <p><b>Clamping ring</b> PEEK: -40 to +100 °C (-40 to +212 °F)</p>
Flow limit	<p>See "Measuring range" (→ <a href="#">97</a>) section</p> <p>The velocity in the measuring tube should not exceed 70 m/s (230 ft/s).</p>
Pressure loss	<p>Negligible.</p> <p>For a precise calculation, use the Applicator.</p>
System pressure	<p><b>Sensor</b> Depending on the version, please note the details on the name plate . Max. 20 bar g (290 psi g)</p>
Thermal insulation	<p>If the gas is very humid or saturated with water, the pipe and the sensor housing should be insulated to prevent water droplets condensing on the transducer.</p>

**NOTICE**

**Electronics overheating on account of thermal insulation!**

- ▶ Observe maximum permitted insulation height of the transmitter neck so that the transmitter head is completely free.

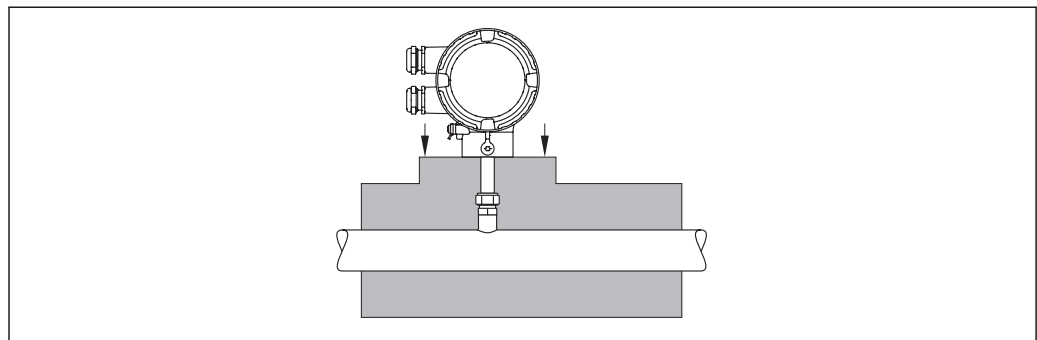

A0015763

## 17.10 Mechanical construction

Design, dimensions	<p> For the dimensions and installation lengths of the device, see the "Technical Information" document, "Mechanical construction" section</p>
--------------------	---

## Weight

**Weight in SI units***Compact version*

Sensor length [mm]	235	335	435	608
Weight [kg] <sup>1)</sup>	2.2	2.3	2.4	2.5

1) Weight of entire measuring device

*Hot tap*

Hot tap versions	[kg]
with retrofit adapter (version V1)	1.8
with weld-in nipple (version V2)	2.2
with flange/flange adapter (version V3)	4.3
Extractor assembly	7.8

**Weight in US units***Compact version*

Sensor length [in]	9	13	17	24
Weight [lbs]	4.8	5.7	5.3	5.5

*Hot tap*

Hot tap versions	[lbs]
with retrofit adapter (version V1)	4.0
with weld-in nipple (version V2)	4.9
with flange/flange adapter (version V3)	9.5
Extractor assembly	17.5

## Materials

**Transmitter housing**

- Order characteristic for "Housing", option **A**: aluminum coating AlSi10Mg
- Window material: glass

**Sensor***Compression fitting:*

- Thread: G 3/4 A, G 1 A, 3/4" NPT, 1" NPT
- Stainless steel 1.4404/1.4571 and 316L/316TI
- Clamping ring: PEEK 450G
- Sealing ring: EPDM/HNBR, 316/316L (outer ring)

*Transducer*

- Stainless steel 1.4404/1.4435 as per EN 10216-5/ EN 10272-5/ EN 10028-7/ EN 10088-2
- Stainless steel 316L as per ASTM A269/ A479/ A240/ A666

**Cable entries**

*Order characteristic for "Housing", option A: compact, aluminum coating*

Electrical connection	Type of protection	Material
Cable gland M20 × 1.5	For non-hazardous areas	Plastic
Thread G ½" via adapter	For non-Ex and Ex	Nickel-plated brass
Thread NPT ½" via adapter		

**Accessories**

*Mounting boss*

1.4404 as per EN 10272 and 316/316L as per ASTM A479

*Hot tap*

- Process connection:
  - Weld-in nipple:  
1.4404 as per EN 10272 and 316/316L as per ASTM A479
  - Flange/flange Adapter:  
1.4404 as per EN 1092-1, 316L as per JIS B 2220, ASME B16.5
- Sensor connection:  
1.4404 as per EN 10216-5 and 316/316L as per ASTM A312
- Ball valve:  
CF3M and CF8M
- Seal:  
PTFE

**17.11 Operability**

Operating concept

**Operator-oriented menu structure for user-specific tasks**

- Commissioning
- Operation
- Diagnostics
- Expert level

**Quick and safe commissioning**

Menu guidance with brief explanations of the individual parameter functions

**Reliable operation**

- Operation in different languages: (→  110)
  - Via local display
  - Via operating tools
- Uniform operating philosophy applied to device and operating tools

**Efficient diagnostics increase measurement reliability**

- Remedial information is integrated in plain text
- Diverse simulation options and optional line recorder functions

## Local operation

**"Display; Operation" Order code option C***Display elements*

- 4-line display
- Format for displaying measured variables and status variables can be individually configured
- Permitted ambient temperature for the display:  $-20$  to  $+60$  °C ( $-4$  to  $+140$  °F)  
The readability of the display may be impaired at temperatures outside the temperature range.

*Operating elements*

Local operation with 3 push buttons (☐, ☐, ☐)

*Additional functionality*

- Data backup function  
The device configuration can be saved in the display module.
- Data comparison function  
The device configuration saved in the display module can be compared to the current device configuration.
- Data transfer function  
The transmitter configuration can be transmitted to another device using the display module.

## Remote operation

**Via HART protocol**

This communication interface is present in the following device version:

- Order code for "Outlet", option **A**: 4-20 mA HART
- Order code for "Outlet", option **B**: 4-20 mA HART, pulse/frequency/switching output

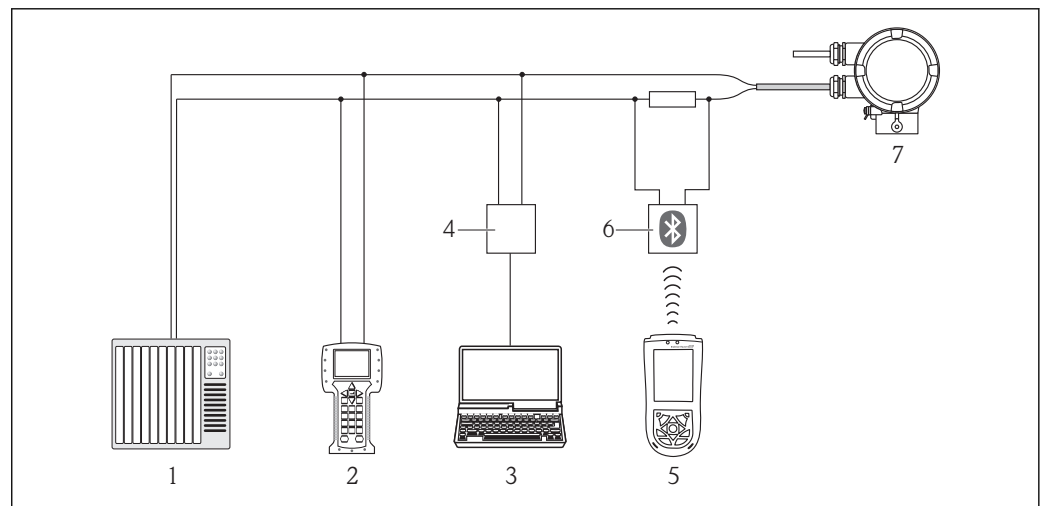

7 Options for remote operation via HART protocol

- 1 Control system (e.g. PLC)
- 2 Field Communicator 475
- 3 Computer with operating tool (e.g. FieldCare, AMS Device Manager, SIMATIC PDM)
- 4 Commubox FXA195 (USB)
- 5 Field Xpert SFX100
- 6 VIATOR Bluetooth modem with connecting cable
- 7 Transmitter

A0017373

**Via service interface (CDI)**

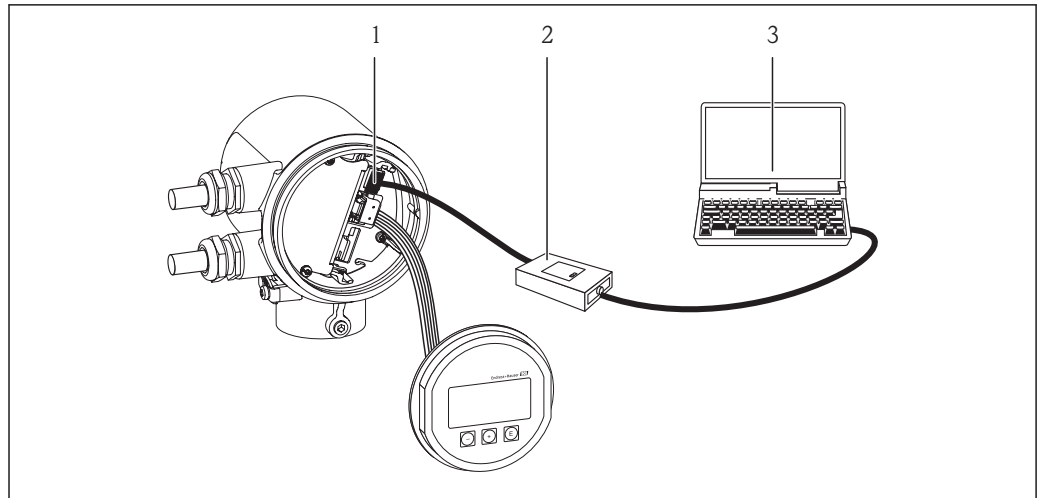

A0017253

- 1 Service interface (CDI) of the measuring device
- 2 Commubox FXA291
- 3 Computer with "FieldCare" operating tool

**Languages**

Can be operated in the following languages:

- Via local display:  
English, German, French, Spanish, Italian, Dutch, Portuguese, Polish, Russian, Turkish, Japanese, Chinese, Korean, Bahasa (Indonesian), Vietnamese, Czech
- Via operating tools:  
English, German, French, Spanish, Italian, Dutch, Portuguese, Polish, Russian, Turkish, Japanese, Chinese, Korean, Bahasa (Indonesian), Vietnamese, Czech

**17.12 Certificates and approvals**

**CE mark**

The measuring system is in conformity with the statutory requirements of the applicable EC Directives. These are listed in the corresponding EC Declaration of Conformity along with the standards applied.

Endress+Hauser confirms successful testing of the device by affixing to it the CE mark.

**C-Tick symbol**

The measuring system meets the EMC requirements of the "Australian Communications and Media Authority (ACMA)".

**Ex approval**

**cCSA<sub>US</sub>**

The following hazardous area version is currently available:

*NI*

Class 1, Division 2, Groups A, B, C and D T4 or Class I

Other standards and guidelines

- EN 60529  
Degrees of protection provided by enclosures (IP code)
- EN 61010-1  
Protection Measures for Electrical Equipment for Measurement, Control, Regulation and Laboratory Procedures
- IEC/EN 61326  
Emission in accordance with Class A requirements. Electromagnetic compatibility (EMC requirements)
- NAMUR NE 21  
Electromagnetic compatibility (EMC) of industrial process and laboratory control equipment
- NAMUR NE 32  
Data retention in the event of a power failure in field and control instruments with microprocessors
- NAMUR NE 43  
Standardization of the signal level for the breakdown information of digital transmitters with analog output signal.
- NAMUR NE 53  
Software of field devices and signal-processing devices with digital electronics
- NAMUR NE 105  
Specifications for integrating fieldbus devices in engineering tools for field devices
- NAMUR NE 107  
Status classification as per NE107

### 17.13 Accessories

 For an overview of the accessories that can be ordered, see the "Technical Information" document

### 17.14 Documentation

-  The following document types are available:
- On the CD-ROM supplied with the device
  - In the Download Area of the Endress+Hauser Internet site: [www.endress.com](http://www.endress.com) → Download

Standard documentation

Communication	Document type	Documentation code
----	Brief Operating Instructions	KA01104D
----	Technical Information	TI01020D

Supplementary device-dependent documentation

Document type	Documentation code
Installation Instructions	Specified for each individual accessory  For an overview of the accessories that can be ordered, see the "Technical Information" document



























## 18 Appendix

























### 18.1 Overview of the Operator/Maintenance operating menu

The following table provides an overview of the operating menu structure with the specific parameters for operators, maintenance staff and experts. The page reference indicates where a description of the parameter can be found in the manual.



























☒ Language (0104)		(→ 48)
<b>Display/operat.</b>	→	(→ 27)
<b>Display</b>	→	(→ 77)
Format display (0098)		(→ 77)
Contrast display (0105)		(→ 77)
Display interval (0096)		(→ 77)
<b>Operation</b>	→	(→ 77)
Control totalizer (0912)		(→ 80)
Preset value (0913)		(→ 80)
Reset all totalizers (2806)		(→ 80)
<b>Setup</b>	→	(→ 49)
Select gas type (3381)		(→ 50)
Process pressure (3376)		(→ 50)
Temperature (1853)		(→ 78)
Pipe shape (3441)		(→ 51)
Pipe inner diameter (3476)		(→ 51)
Duct internal height (3405)		(→ 51)
Duct internal width (3411)		(→ 51)
Installation factor (3470)		(→ 51)
Assign current output (0359)		(→ 53)
4 mA value (0367)		(→ 53)
20 mA value (0372)		(→ 53)
Operating mode (0469)		(→ 53)
Assign frequency output (0478)		(→ 53)



Measuring value at minimum frequency (0476)		(→  53)
Measuring value at maximum frequency (0475)		(→  53)
Switch output function (0481)		(→  54)
Assign limit (0483)		(→  54)
Switch-off value (0464)		(→  54)
Switch-on value (0466)		(→  54)
Assign pulse output (0460)		(→  54)
Value per pulse (0455)		(→  54)
	<b>Advanced setup</b> →	(→  55)
	Enter access code (0092)	(→  74)
	Define access code (0093)	(→  74)
	Device tag (0215)	(→  56)
	<b>Applications</b> →	(→  56)
	Select gas type (3381)	(→  57)
	Process pressure (3376)	(→  57)
	Temperature (1853)	(→  57)
	Reference conditions (3439)	(→  57)
	Reference pressure (3378)	(→  57)
	Reference temperature (3379)	(→  57)
	<b>FAD conditions</b> →	(→  56)
	FAD conditions (3438)	(→  57)
	FAD pressure (3373)	(→  57)
	FAD temperature (3374)	(→  57)
	<b>System units</b> →	(→  57)
	Mass flow unit (0554)	(→  58)
	Mass unit (0574)	(→  58)
	Corrected volume flow unit (0558)	(→  58)

Corrected volume unit (0575)		(→  58)
FAD volume flow unit (0601)		(→  58)
FAD volume unit (0591)		(→  58)
Density unit (0555)		(→  58)
Pressure unit (0564)		(→  58)
Temperature unit (0557)		(→  58)
Length unit (0551)		(→  58)
<b>Current output</b>	→	(→  59)
Assign current output (0359)		(→  60)
Mass flow unit (0554)		(→  60)
Corrected volume flow unit (0558)		(→  60)
FAD volume flow unit (0601)		(→  60)
Temperature unit (0557)		(→  60)
<b>PFS output</b>	→	(→  62)
Operating mode (0469)		(→  63)
Assign pulse (0460)		(→  63)
Assign frequency (0478)		(→  63)
Switch output function (0481)		(→  63)
Assign diagnostic behavior (0482)		(→  63)
Assign limit (0483)		(→  63)
Assign status (0485)		(→  63)
Mass flow unit (0554)		(→  63)
Mass unit (0574)		(→  63)
FAD volume flow unit (0601)		(→  63)
FAD volume unit (0591)		(→  63)
Corrected volume flow unit (0558)		(→  63)
Corrected volume unit (0575)		(→  63)

























Unit (0915)	(→  63)
Temperature unit (0557)	(→  63)
Value per pulse (0455)	(→  63)
Pulse width (0452)	(→  63)
Failure mode (0480)	(→  63)
Minimum frequency value (0453)	(→  63)
Maximum frequency value (0454)	(→  63)
Maximum frequency value (0454)	(→  63)
Minimum frequency value (0453)	(→  63)
Measuring value at minimum frequency (0476)	(→  63)
Measuring value at maximum frequency (0475)	(→  63)
Measuring value at maximum frequency (0475)	(→  63)
Measuring value at minimum frequency (0476)	(→  63)
Failure mode (0451)	(→  63)
Failure frequency (0474)	(→  63)
Switch-on value (0466)	(→  63)
Switch-off value (0464)	(→  63)
Switch-off value (0464)	(→  63)
Switch-on value (0466)	(→  63)
Switch-on delay (0467)	(→  63)
Switch-off delay (0465)	(→  63)
Failure mode (0486)	(→  63)
Invert output signal (0470)	(→  63)
<b>Output conduct</b> →	(→  67)
Display damping (0094)	(→  67)

	<b>Current output</b>	→	(→  67)
	Response time (0378)		(→  67)
	Damping output (0363)		(→  67)
	<b>PFS output</b>	→	(→  67)
	Response time (0491)		(→  67)
	Damping output (0477)		(→  67)
	<b>Low flow cut off</b>	→	(→  68)
	Assign process variable (1837)		(→  68)
	On value low flow cutoff (1805)		(→  68)
	Off value low flow cutoff (1804)		(→  68)
	<b>Totalizer</b>	→	(→  69)
	Assign process variable (0914)		(→  69)
	Unit (0915)		(→  69)
	Failure mode (901)		(→  69)
	<b>Display</b>	→	(→  69)
	Format display (0098)		(→  69)
	Value 1 display (0107)		(→  70)
	0% bargraph value 1 (0123)		(→  70)
	100% bargraph value 1 (0125)		(→  70)
	Decimal places 1 (0095)		(→  70)
	Value 2 display (0108)		(→  70)
	Decimal places 2 (0117)		(→  70)
	Value 3 display (0110)		(→  70)
	0% bargraph value 3 (0124)		(→  70)
	100% bargraph value 3 (0126)		(→  70)
	Decimal places 3 (0118)		(→  70)
	Value 4 display (0109)		(→  70)

	Decimal places 4 (0119)	(→ <a href="#">71</a> )
	Display interval (0096)	(→ <a href="#">71</a> )
	Display damping (0094)	(→ <a href="#">71</a> )
	Header (0097)	(→ <a href="#">71</a> )
	Header text (0112)	(→ <a href="#">71</a> )
	Separator (0101)	(→ <a href="#">71</a> )
	<b>Conf. backup disp.</b> →	(→ <a href="#">71</a> )
	Operating time (0652)	(→ <a href="#">71</a> )
	Last backup (0102)	(→ <a href="#">71</a> )
	Configuration management (0100)	(→ <a href="#">72</a> )
	Comparison result (0103)	(→ <a href="#">72</a> )
<b>Diagnostics</b> →		(→ <a href="#">82</a> )
Actual diagnostics (0691)		(→ <a href="#">82</a> )
Previous diagnostics (0690)		(→ <a href="#">82</a> )
Operating time from restart (0653)		-
Operating time (0652)		(→ <a href="#">71</a> )
<b>Diagnostics list</b> →		(→ <a href="#">90</a> )
Diagnostics 1 to 5(0696)		(→ <a href="#">90</a> )
<b>Event logbook</b> →		(→ <a href="#">90</a> )
Filter options (0705)		(→ <a href="#">91</a> )
<b>Events list</b> →		(→ <a href="#">91</a> )
<b>Device info</b> →		(→ <a href="#">46</a> )
Device tag (0011)		(→ <a href="#">93</a> )
Serial number (0009)		(→ <a href="#">93</a> )
Firmware version (0010)		(→ <a href="#">46</a> )
Device name (0013)		(→ <a href="#">46</a> )
Order code (0008)		(→ <a href="#">46</a> )
Extended order code 1 (0023)		(→ <a href="#">46</a> )

Extended order code 2 (0021)		(→ <a href="#">46</a> )
Extended order code 3 (0022)		(→ <a href="#">46</a> )
ENP version (0012)		(→ <a href="#">46</a> )
Device revision (0204)		(→ <a href="#">46</a> )
Device ID (0221)		(→ <a href="#">46</a> )
Device type (0222)		(→ <a href="#">46</a> )
Manufacturer ID (0223)		(→ <a href="#">46</a> )
<b>Measured values</b>	→	(→ <a href="#">77</a> )
	<b>Process variables</b>	→ (→ <a href="#">78</a> )
	Mass flow (1838)	(→ <a href="#">78</a> )
	Corrected volume flow (1847)	(→ <a href="#">78</a> )
	FAD volume flow (1851)	(→ <a href="#">78</a> )
	Temperature (1853)	(→ <a href="#">78</a> )
	<b>Totalizer</b>	→ (→ <a href="#">78</a> )
	Totalizer value (0911)	(→ <a href="#">79</a> )
	Totalizer overflow (0910)	(→ <a href="#">79</a> )
	<b>Output values</b>	→ (→ <a href="#">79</a> )
	Output current (0361)	(→ <a href="#">79</a> )
	Pulse output (0456)	(→ <a href="#">79</a> )
	Output frequency (0471)	(→ <a href="#">79</a> )
	Switch status (0461)	(→ <a href="#">79</a> )
	<b>Data logging</b>	→ (→ <a href="#">81</a> )
	Assign channel 1 (0851)	(→ <a href="#">81</a> )
	Assign channel 2 (0852)	(→ <a href="#">81</a> )
	Assign channel 3 (0853)	(→ <a href="#">81</a> )
	Assign channel 4 (0854)	(→ <a href="#">81</a> )
	Logging interval (0856)	(→ <a href="#">81</a> )
	Clear logging data (0855)	(→ <a href="#">81</a> )
	<b>Display channel 1</b>	→ (→ <a href="#">81</a> )



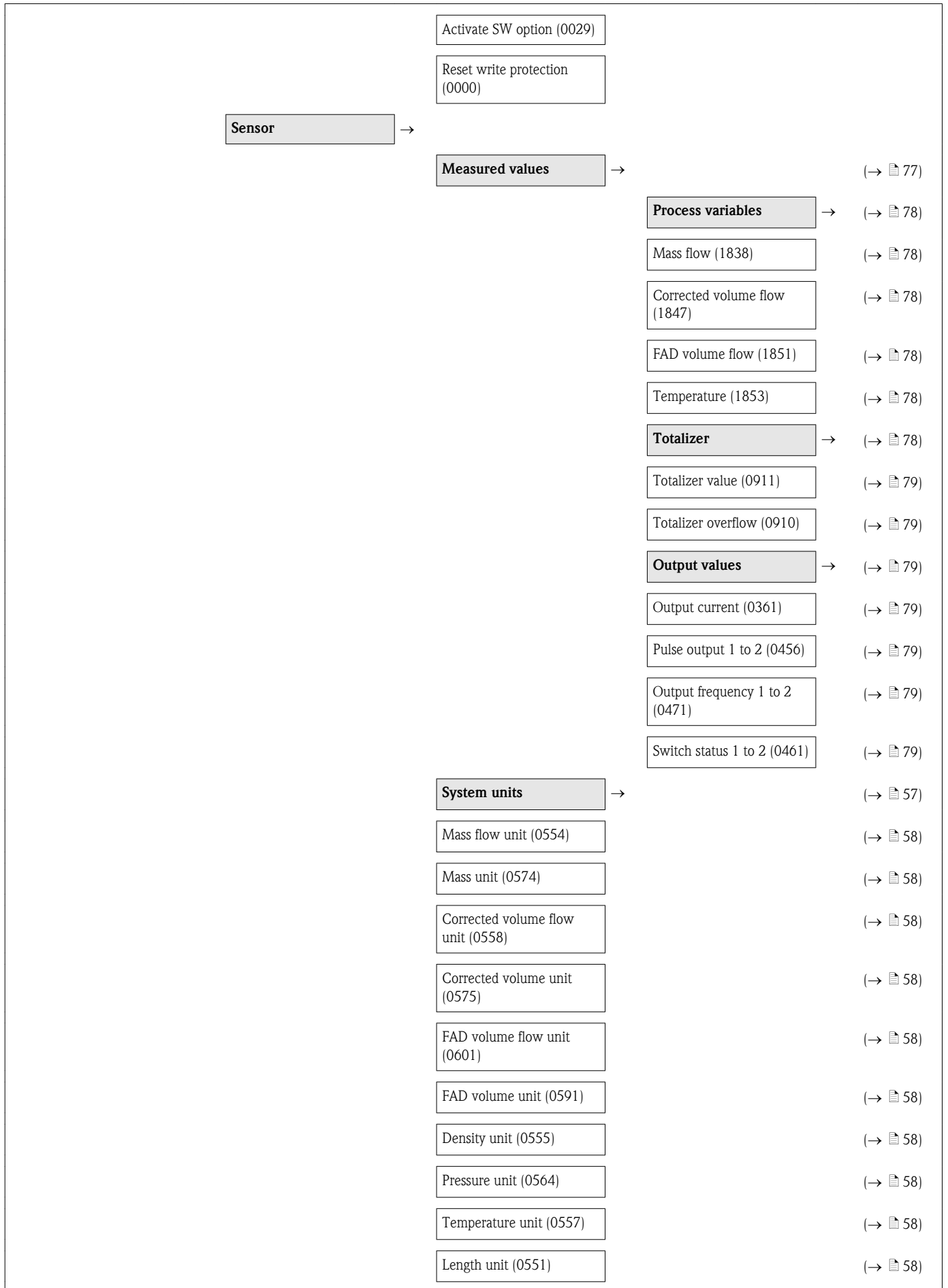

	<b>Display channel 2</b>	→	(→ 81)
	<b>Display channel 3</b>	→	(→ 81)
	<b>Display channel 4</b>	→	(→ 81)
	<b>Simulation</b>	→	(→ 72)
	Assign simulation process variable (1810)		(→ 73)
	Value process variable (1811)		(→ 73)
	Simulation current output 1 (0354)		(→ 73)
	Value current output 1 (0355)		(→ 73)
	Frequency simulation (0472)		(→ 73)
	Frequency value (0473)		(→ 73)
	Pulse simulation (0458)		(→ 73)
	Pulse value (0459)		(→ 73)
	Switch output simulation (0462)		(→ 73)
	Switch status (0463)		(→ 73)
	Simulation device alarm (0654)		(→ 73)
	<b>Device reset</b>	→	(→ 90)
	Device reset		(→ 90)
	<b>Expert</b>	→	
	Direct access (0106)		(→ 32)
	Locking status (0122)		(→ 30)
	Access stat.display (0091)		
	<b>System</b>	→	
	Enter access code (0003)		(→ 74)
	Define access code (0093)		(→ 74)
	<b>Display</b>	→	(→ 77)
	Language (0104)		(→ 48)
	Format display (0098)		(→ 69)
	Value 1 display (0107)		(→ 70)

0% bargraph value 1 (0123)		(→  70)
100% bargraph value 1 (0125)		(→  70)
Decimal places 1 (0095)		(→  70)
Value 2 display (0108)		(→  70)
Decimal places 2 (0117)		(→  70)
Value 3 display (0110)		(→  70)
0% bargraph value 3 (0124)		(→  70)
100% bargraph value 3 (0126)		(→  70)
Decimal places 3 (0118)		(→  70)
Value 4 display (0109)		(→  70)
Decimal places 4 (0119)		(→  71)
Display interval (0096)		(→  71)
Display damping (0094)		(→  71)
Header (0097)		(→  71)
Header text (0112)		(→  71)
Separator (0101)		(→  71)
Contrast display (0105)		(→  77)
Access status display (0091)		(→  41)
<b>Conf. backup disp.</b>	→	(→  71)
Operating time		(→  71)
Last backup		(→  71)
Configuration management		(→  72)
Comparison result		(→  72)
<b>Diagnostic behavior</b>	→	
Alarm delay	→	
		<b>Diagnostic behavior</b> →
<b>Management</b>	→	
Device reset (0000)		(→  90)





Date/time format (2812)		
	<b>User spec. units</b>	→
	User mass text (560)	
	User mass offset (562)	
	User mass factor (561)	
	<b>Process param.</b>	→
	Flow override (1839)	
	Flow damping (1802)	
	<b>Low flow cut off</b>	→ (→ 68)
	Assign process variable (1837)	(→ 68)
	On value low flow cutoff (1805)	(→ 68)
	Off value low flow cutoff (1804)	(→ 68)
	<b>Calculated value</b>	→
	<b>Reference values</b>	→
	Reference conditions (3439)	(→ 57)
	Reference pressure (3378)	(→ 57)
	Reference temperature (3379)	(→ 57)
	Reference density (3377)	
	FAD conditions (3438)	(→ 57)
	FAD pressure (3473)	(→ 57)
	FAD temperature (3474)	(→ 57)
	FAD density (3372)	
	<b>Fluid properties</b>	→
	Density (3462)	
	Reference density (3377)	
	FAD density (3372)	
	<b>Sensor adjustment</b>	→
	<b>Installation settings</b>	→
	Installation factor (3470)	(→ 51)



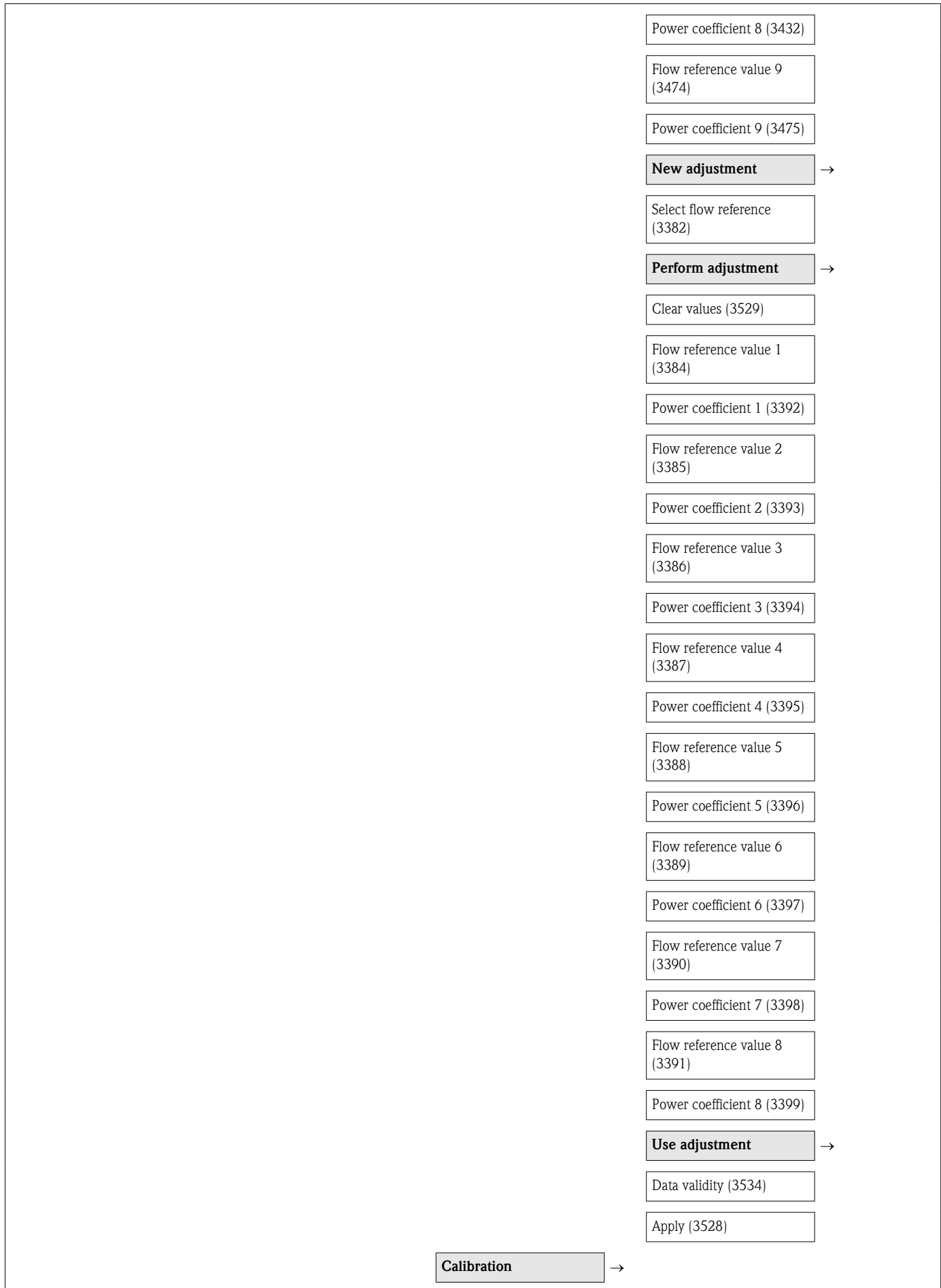





















Pipe shape (3441)	(→  51)
Pipe inner diameter (3476)	(→  51)
Duct internal height (3405)	(→  51)
Duct internal width (3411)	(→  51)
Orientation (3437)	
Pipe wall thickness (3409)	
Mounting set height (3435)	
Insertion depth (3406)	
<b>In-situ adjustment</b>	→
Operating mode (3400)	
<b>Values in use</b>	→
Flow reference in use (3440)	
Flow reference value 1 (3401)	
Power coefficient 1 (3425)	
Flow reference value 2 (3418)	
Power coefficient 2 (3426)	
Flow reference value 3 (3419)	
Power coefficient 3 (3427)	
Flow reference value 4 (3420)	
Power coefficient 4 (3428)	
Flow reference value 5 (3421)	
Power coefficient 5 (3429)	
Flow reference value 6 (3422)	
Power coefficient 6 (3430)	
Flow reference value 7 (3423)	
Power coefficient 7 (3431)	
Flow reference value 8 (3424)	



	Flow conditioner (3404)	
	Calibration date/time (3436)	
<b>Output</b> →		
	<b>Current output 1</b> →	(→ <a href="#">59</a> )
	Assign current output (359)	(→ <a href="#">60</a> )
	Current span (353)	(→ <a href="#">60</a> )
	Fixed current (365)	(→ <a href="#">60</a> )
	4mA value (367)	(→ <a href="#">60</a> )
	20mA value (372)	(→ <a href="#">60</a> )
	Damping (363)	(→ <a href="#">67</a> )
	Response time (378)	(→ <a href="#">67</a> )
	Failure mode (364)	
	Output current (361)	(→ <a href="#">79</a> )
	Start-up mode (368)	
	<b>PFS output 1</b> →	
	Operating mode (469)	(→ <a href="#">53</a> )
	Assign pulse (460)	(→ <a href="#">54</a> )
	Value per pulse (455)	(→ <a href="#">54</a> )
	Pulse width (452)	(→ <a href="#">63</a> )
	Failure mode (480)	(→ <a href="#">63</a> )
	Pulse output (456)	(→ <a href="#">79</a> )
	Assign frequency (478)	(→ <a href="#">53</a> )
	Minimum frequency value (453)	(→ <a href="#">63</a> )
	Maximum frequency value (454)	(→ <a href="#">63</a> )
	Measuring value at minimum frequency (476)	(→ <a href="#">63</a> )
	Measuring value at maximum frequency (475)	(→ <a href="#">63</a> )
	Damping output (477)	(→ <a href="#">67</a> )
	Response time (491)	(→ <a href="#">67</a> )

	Failure mode (451)	(→ <a href="#">63</a> )
	Output frequency (471)	(→ <a href="#">79</a> )
	Switch output function (481)	(→ <a href="#">54</a> )
	Assign diagnostic behavior (482)	(→ <a href="#">63</a> )
	Assign limit (483)	(→ <a href="#">63</a> )
	Switch-on value (466)	(→ <a href="#">54</a> )
	Switch-off value (464)	(→ <a href="#">54</a> )
	Assign status (485)	(→ <a href="#">54</a> )
	Switch-on delay (467)	(→ <a href="#">63</a> )
	Switch-off delay (465)	(→ <a href="#">63</a> )
	Failure mode (486)	(→ <a href="#">63</a> )
	Switch status (461)	(→ <a href="#">79</a> )
	Invert output signal (470)	(→ <a href="#">63</a> )
<b>Communication</b> →		
	<b>HART output</b> →	
		<b>Configuration</b> →
		Burst mode (208)
		Burst command (207)
		HART address (219)
		No. of preambles (217)
		HART short tag (220)
		<b>Information</b>
		Device revision (204) (→ <a href="#">46</a> )
		Device ID (221) (→ <a href="#">46</a> )
		Device type (222) (→ <a href="#">46</a> )
		Manufacturer ID (223) (→ <a href="#">46</a> )
		HART revision (205)
		HART descriptor (212)
		HART message (216)
		HART date code (202)

	Hardware revision (206)	
	Software revision (224)	
	<b>Output</b>	(→  46)
	Assign PV (234)	(→  46)
	Primary variable (PV) (201)	(→  46)
	Assign SV (235)	(→  46)
	Secondary variable (SV) (226)	(→  46)
	Assign TV (236)	(→  46)
	Tertiary variable (TV) (228)	(→  46)
	Assign QV (237)	(→  46)
	Quaternary variable (QV) (203)	(→  46)
<b>Application</b> →		
Reset all totalizers (2806)		(→  80)
	<b>Totalizer</b> →	
	Assign process variable (914)	(→  69)
	Unit (915)	(→  69)
	Control totalizer (912)	(→  80)
	Preset value (913)	(→  80)
	Failure mode (901)	(→  69)
<b>Diagnostics</b> →		
Actual diagnostics (691)		(→  82)
Previous diagnostics (690)		(→  82)
Operating time from restart (653)		-
Operating time (652)		(→  71)
	<b>Diagnostics list</b> →	(→  90)
	Diagnostics 1 (692)	(→  90)
	Diagnostics 2 (693)	(→  90)
	Diagnostics 3 (694)	(→  90)
	Diagnostics 4 (695)	(→  90)

Diagnostics 5 (696)		(→  90)
<b>Event logbook</b>	→	(→  90)
Filter options (705)		(→  91)
<b>Device info</b>	→	(→  46)
Device tag (11)		(→  93)
Serial number (9)		(→  93)
Firmware version (10)		(→  46)
Device name (13)		(→  46)
Order code (8)		(→  46)
Extended order code 1 (23)		(→  46)
Extended order code 2 (21)		(→  46)
Extended order code 3 (22)		(→  46)
ENP version (12)		(→  46)
Configuration counter (233)		
<b>Data logging</b>	→	(→  81)
Assign channel 1 (851)		(→  81)
Assign channel 2 (852)		(→  81)
Assign channel 3 (853)		(→  81)
Assign channel 4 (854)		(→  81)
Logging interval (856)		(→  81)
Clear logging data (855)		(→  81)
		<b>Display channel 1</b> → (→  81)
		<b>Display channel 2</b> → (→  81)
		<b>Display channel 3</b> → (→  81)
		<b>Display channel 4</b> → (→  81)
<b>Data logging</b>	→	
		<b>Electronics temperature</b> →
		Minimum value (3445)
		Maximum value (3444)



	<b>Process temperature</b> →	
	Minimum value (3447)	
	Maximum value (3446)	
	<b>Simulation</b> →	(→  72)
	Assign process variable (1810)	(→  73)
	Value process variable (1811)	(→  73)
	Simulation current output 1 (354)	(→  73)
	Value current output 1 (355)	(→  73)
	Frequency simulation (472)	(→  73)
	Frequency value (473)	(→  73)
	Pulse simulation (458)	(→  73)
	Pulse value (459)	(→  73)
	Switch output simulation (462)	(→  73)
	Pulse value (463)	(→  73)
	Simulation device alarm (654)	(→  73)

# Index

## A

Access authorization to parameters	
Read access	41
Write access	41
Access code	41
Incorrect input	41
Adapting the diagnostic behavior	87
Ambient temperature range	19, 105
AMS Device Manager	43
Function	43
Application	8, 97
Applicator	97, 97, 98
Approvals	110

## C

C-Tick symbol	110
Cable entries	
Technical data	103
Cable entry	
Degree of protection	25
Cable specification	23, 103
CE mark	110
CE mark (declaration of conformity)	9
Certificates	110
Characteristic values	97
Check	
Installation	22
Post-connection	26
Received goods	11
Checklist	
Post-connection check	26
Post-mounting check	22
Cleaning	
Cleaning the transducer	94
Exterior cleaning	94
Interior cleaning	94
Commissioning	48
Advanced settings	55
Configuring the measuring device	49
Communication-specific data	46
Connecting cable	
Requirements	23
Connecting the measuring device	24
Connection preparations	24
Connection tools	23
Context menu	
Calling up	36
Close	36
Explanation	36
Current consumption	103

## D

Declaration of Conformity	9
Declaration of Contamination	95
Define access code	74
Degree of protection	25, 105

## Design

Measuring device	10
Designated use	8
Device components	10
Device description files	46, 46
Device documentation	
Supplementary documentation	7
Device name	
Sensor	13
Transmitter	12
Device repair	93
Device revision	46
Device type ID	46
Diagnosis	
Symbols	84
Diagnostic behavior	
Explanation	84
Symbols	84
Diagnostic information	85
In the operating tool	86
Local display	84
Overview	88
Remedy information	88
Diagnostic message	84
Diagnostics list	90
DIP switch	
see Write protection switch	
Direct access	38
Direct access code	32
Disabling write protection	73
Display	
see Local display	
Display area	
For operational display	31
In the navigation view	33
Display values	
For output values	79
For process variables	78
For the totalizer	78
Disposal	96
Document	
Function	5
Symbols used	5
Document function	5

## E

Electrical connection	
Commubox FXA191, 195	44
Commubox FXA195	109
Commubox FXA291	45, 110
Degree of protection	25
Field Communicator	44, 109
Handheld terminals	44, 109
Measuring device	23
Operating tools	44, 109

- Via HART protocol . . . . . 44, 109
  - Via service interface (CDI) . . . . . 45, 110
  - Electromagnetic compatibility . . . . . 105
  - Electronic modules . . . . . 25
  - Electronics board
    - I/O electronics modules . . . . . 25
  - Electronics housing
    - Turning
      - see Turning the transmitter housing
  - Electronics module . . . . . 10
  - Enabling write protection . . . . . 73
  - Endress+Hauser services
    - About maintenance . . . . . 94
    - About repair . . . . . 93
  - Error messages
    - see Diagnostic messages
  - Event history . . . . . 90
  - Events list . . . . . 90
  - Ex approval . . . . . 110
  - Extended order code
    - Sensor . . . . . 13
    - Transmitter . . . . . 12
  - Exterior cleaning . . . . . 94
- F**
- Field Communicator
    - Function . . . . . 44
  - Field Communicator 475 . . . . . 44
  - Field of application
    - Residual risks . . . . . 9
  - Field Xpert . . . . . 43
    - Function . . . . . 43
  - FieldCare . . . . . 43
    - Function . . . . . 43
    - User interface . . . . . 43
  - Filtering the event logbook . . . . . 91
  - Firmware
    - Release date . . . . . 46
    - Version . . . . . 46
  - Flow direction . . . . . 15, 20
  - Flow limit . . . . . 106
  - Function check . . . . . 48
  - Function range
    - AMS Device Manager . . . . . 43
    - Field Xpert . . . . . 43
    - FieldCare . . . . . 43
    - SIMATIC PDM . . . . . 44
  - Function scope
    - Field Communicator . . . . . 44
    - Field Communicator 475 . . . . . 44
  - Functions
    - see Parameter
- G**
- Galvanic isolation . . . . . 101
- H**
- HART protocol
    - Device variables . . . . . 46
- Measured variables . . . . . 46
  - Revision . . . . . 46
  - Help text
    - Calling up . . . . . 39
    - Close . . . . . 39
    - Explanation . . . . . 39
  - HistoROM (description) . . . . . 71
- I**
- Identifying the measuring device . . . . . 12
  - Incoming acceptance . . . . . 11
  - Influence
    - Medium pressure . . . . . 105
  - Information on the document . . . . . 5
  - Inlet runs . . . . . 18
  - Input mask . . . . . 34
  - Installation . . . . . 15
  - Installation conditions
    - Inlet and outlet runs . . . . . 18
    - Installation dimensions . . . . . 18
    - Mounting location . . . . . 15
    - Orientation . . . . . 15
    - System pressure . . . . . 19, 106
    - Thermal insulation . . . . . 19, 106
  - Installation dimensions . . . . . 18
  - Interior cleaning . . . . . 94
- K**
- Keypad lock
    - Disabling . . . . . 41
    - Enabling . . . . . 41
- L**
- Languages, local operation . . . . . 110
  - Line recorder . . . . . 81
  - Load . . . . . 23
  - Local display . . . . . 109
    - Editing view . . . . . 34
    - Navigation view . . . . . 32
    - see Diagnostic message
    - see In alarm condition
    - see Operational display
  - Local operation
    - Languages . . . . . 110
  - Low flow cut off . . . . . 101
- M**
- Main electronics module . . . . . 10
  - Maintenance . . . . . 94
  - Maintenance tasks . . . . . 94
  - Managing the device configuration . . . . . 71
  - Manufacturer ID . . . . . 46
  - Manufacturing date . . . . . 12, 13
  - Materials . . . . . 107
  - Maximum measured error . . . . . 104
  - Measured variables
    - Calculated . . . . . 97
    - Direct . . . . . 97
    - see Process variables
  - Measuring and test equipment . . . . . 94

- Measuring device
    - Configuration . . . . . 49
    - Conversion . . . . . 93
    - Design . . . . . 10
    - Disposal . . . . . 96
    - Enabling . . . . . 48
    - Integrating via HART protocol . . . . . 46
    - Mounting the sensor . . . . . 20
    - Preparing for electrical connection . . . . . 24
    - Preparing for mounting . . . . . 20
    - Removing . . . . . 96
    - Repair . . . . . 93
    - Return . . . . . 95
  - Measuring principle . . . . . 97
  - Measuring range . . . . . 97
    - Calibrated . . . . . 97
    - Extended . . . . . 98
  - Measuring range, recommended . . . . . 106
  - Measuring system . . . . . 97
  - Media . . . . . 8
  - Medium pressure
    - Influence . . . . . 105
  - Menus
    - For measuring device configuration . . . . . 49
    - For specific settings . . . . . 55
  - Mounting dimensions
    - see Installation dimensions
  - Mounting location . . . . . 15
  - Mounting preparations . . . . . 20
  - Mounting tools . . . . . 20
- N**
- Nameplate
    - Sensor . . . . . 13
    - Transmitter . . . . . 12
  - Navigation path (navigation view) . . . . . 32
  - Navigation view
    - In the wizard . . . . . 32
    - Of the submenu . . . . . 32
  - Numeric editor . . . . . 34
- O**
- Operable flow range . . . . . 99
  - Operating elements . . . . . 35, 85
  - Operating keys
    - see Operating elements
  - Operating menu
    - Design . . . . . 27
    - Menus, submenus . . . . . 27
    - Submenus and user roles . . . . . 29
    - Wizards . . . . . 27
  - Operating menu overview
    - Operators and maintenance . . . . . 112
  - Operating philosophy . . . . . 29
  - Operating tools
    - Connection overview . . . . . 44
  - Operation . . . . . 77
  - Operation options . . . . . 27, 27
  - Operational display . . . . . 30
  - Operational safety . . . . . 9
  - Order code . . . . . 12, 12, 13
  - Orientation (vertical, horizontal) . . . . . 15
  - Outlet run
    - Pressure measuring device . . . . . 19
  - Outlet runs . . . . . 18
  - Output . . . . . 99
  - Output signal . . . . . 99
- P**
- Packaging disposal . . . . . 14
  - Parameter
    - Changing . . . . . 40
    - Enter a value . . . . . 40
  - Parameter settings
    - Assign current output . . . . . 53
    - Duct internal height, duct internal width . . . . . 51
    - For applications . . . . . 56
    - For conf. backup disp. . . . . 71
    - For local display . . . . . 69, 77
    - For low flow cut off . . . . . 68
    - For medium selection and setting . . . . . 50
    - For pulse/frequency/switch output . . . . . 53
    - For simulation . . . . . 72
    - For system units . . . . . 58, 60, 63
    - For the installation factor setting . . . . . 52
    - For the operation . . . . . 80
    - For the process pressure setting . . . . . 50
    - For the totalizer . . . . . 67, 69
    - Pipe inner diameter . . . . . 51
    - Pipe shape . . . . . 51
  - Performance characteristics . . . . . 104
  - Post-connection
    - see Electrical connection
  - Post-connection check (checklist) . . . . . 26
  - Post-installation check . . . . . 48
  - Post-mounting check (checklist) . . . . . 22
  - Potential equalization . . . . . 103
  - Power supply failure . . . . . 103
  - Pressure loss . . . . . 106
  - Product safety . . . . . 9
  - Protecting parameter settings . . . . . 73
- R**
- Read access . . . . . 41
  - Reading measured values . . . . . 77
  - Recalibration . . . . . 94
  - Reference operating conditions . . . . . 104
  - Registered trademarks . . . . . 10
  - Remedial measures
    - Calling up . . . . . 86
    - Closing . . . . . 86
  - Remote operation . . . . . 109
  - Repair . . . . . 93
    - Concept . . . . . 93
    - Notes . . . . . 93
  - Repair of a device . . . . . 93
  - Repeatability . . . . . 105
  - Replacement

- Device components . . . . . 93
- Requirements for personnel . . . . . 8
- Response time . . . . . 105
- Returning the measuring device . . . . . 95
- S**
- Safety
  - Safety instructions . . . . . 8
- Seals
  - Medium temperature range . . . . . 106
- Sensor
  - Medium temperature range . . . . . 106
  - Mounting . . . . . 20
  - System pressure . . . . . 19, 106
- Serial number . . . . . 12, 13
- Setting the operating language . . . . . 48
- Settings
  - Adapting the measuring device to the process conditions . . . . . 80
  - Applications . . . . . 56
  - Current output . . . . . 59, 62
  - Device reset . . . . . 90
  - Device tag . . . . . 56
  - Installation factor . . . . . 51
  - Local display . . . . . 69
  - Low flow cut off . . . . . 68
  - Managing the device configuration . . . . . 71
  - Medium . . . . . 50, 50
  - Operating language . . . . . 48
  - Pipe shape . . . . . 51, 51, 51, 53
  - Pulse/frequency/switch output . . . . . 53
  - Resetting the totalizer . . . . . 80
  - Sensor data . . . . . 51
  - Simulation . . . . . 72
  - System units . . . . . 57
  - Totalizer . . . . . 67, 69
  - Totalizer reset . . . . . 80
- Shock resistance . . . . . 105
- Showing data logging . . . . . 81
- Signal on alarm . . . . . 100
- SIMATIC PDM . . . . . 44
  - Function . . . . . 44
- Software release . . . . . 46
- Spare part . . . . . 93
- Spare parts . . . . . 93
  - Concept . . . . . 93
  - Nameplate . . . . . 93
- Standards and guidelines . . . . . 111
- Status area
  - For operational display . . . . . 30
  - In the navigation view . . . . . 32
- Status signals . . . . . 84
- Storage conditions . . . . . 14
- Storage temperature . . . . . 14
- Structure of the operating menu . . . . . 27
- Submenu
  - Conf. backup disp. . . . . 71
  - Current output . . . . . 60
  - Data logging . . . . . 81
- Events list . . . . . 90
- Local display . . . . . 68
- Operation . . . . . 77, 80
- Output values . . . . . 79
- PFS output . . . . . 62
- Process variables . . . . . 77
- Simulation . . . . . 72
- System units . . . . . 57
- Totalizer . . . . . 67, 69, 78
- Submenus . . . . . 29
- Supply unit
  - Requirements . . . . . 23
- Supply voltage . . . . . 23, 23, 102
- Symbols
  - For communication . . . . . 30
  - For correction . . . . . 34
  - For diagnostic behavior . . . . . 30
  - For locking . . . . . 30
  - For measured variable . . . . . 31
  - For measurement channel number . . . . . 31
  - For menus . . . . . 33
  - For parameters . . . . . 33
  - For status signal . . . . . 30
  - For submenu . . . . . 33
  - For wizard . . . . . 33
  - In the status area of the local display . . . . . 30
  - In the text and numeric editor . . . . . 34
- System design
  - Measuring system . . . . . 97
  - see Measuring device design
- System integration . . . . . 46
- System pressure . . . . . 19, 106
- T**
- Technical data, overview . . . . . 97
- Temperature range
  - Ambient temperature . . . . . 19, 105
  - Ambient temperature range for display . . . . . 109
  - Medium temperature . . . . . 106
  - Storage temperature . . . . . 14
- Terminal assignment . . . . . 25, 102
- Terminal voltage . . . . . 23
- Terminals . . . . . 103
- Text editor . . . . . 34
- Thermal insulation . . . . . 19, 106
- Tool tip
  - see Help text
- Tools
  - For electrical connection . . . . . 23
  - For mounting . . . . . 20
  - Transport . . . . . 14
- Transmitter
  - Connecting the signal cables . . . . . 25
  - Turning the display module . . . . . 21
  - Turning the housing . . . . . 21
- Transmitter housing
  - Turning . . . . . 21
- Transporting the measuring device . . . . . 14
- Troubleshooting

General . . . . .	82
Turning the display module . . . . .	21

## U

Use of the measuring device	
see Designated use	
Use of the measuring devices	
Borderline cases . . . . .	8
Incorrect use . . . . .	8
User interface	
FieldCare . . . . .	43
User roles . . . . .	29

## V

Version data for the device . . . . .	46
Vibration resistance . . . . .	105

## W

W@M . . . . .	93, 94
W@M Device Viewer . . . . .	12, 93
Weight	
SI units . . . . .	107
Transport (notes) . . . . .	14
US units . . . . .	107
Workplace safety . . . . .	9
Write access . . . . .	41
Write protection	
Via access code . . . . .	74
Via write protection switch . . . . .	74
Write protection switch . . . . .	74



[www.endress.com/worldwide](http://www.endress.com/worldwide)

---

**Endress+Hauser** 

People for Process Automation

---