

## Brief Operating Instructions

# Proline t-mass B 150

## Thermal Mass Flow Measuring System

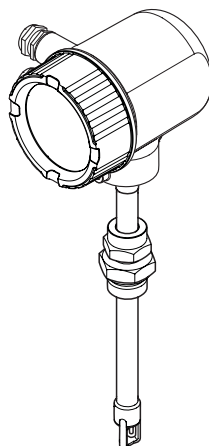

These Instructions are Brief Operating Instructions; they do not replace the Operating Instructions included in the scope of supply.

For detailed information, refer to the Operating Instructions and other documentation on the CD-ROM provided or visit "[www.endress.com/deviceviewer](http://www.endress.com/deviceviewer)".





# Table of contents

<b>1 Document information</b> . . . . .	<b>3</b>
1.1 Document conventions . . . . .	3
<b>2 Basic safety instructions</b> . . . . .	<b>5</b>
2.1 Requirements for the personnel . . . . .	5
2.2 Designated use . . . . .	5
2.3 Workplace safety . . . . .	6
2.4 Operational safety . . . . .	6
2.5 Product safety . . . . .	6
<b>3 Product description</b> . . . . .	<b>7</b>
3.1 Product design . . . . .	7
<b>4 Incoming acceptance and product identification</b> . . . . .	<b>8</b>
4.1 Incoming acceptance . . . . .	8
4.2 Product identification . . . . .	9
<b>5 Storage and transport</b> . . . . .	<b>10</b>
5.1 Storage conditions . . . . .	10
5.2 Transporting the product . . . . .	10
5.3 Packaging disposal . . . . .	10
<b>6 Installation</b> . . . . .	<b>11</b>
6.1 Installation conditions . . . . .	11
6.2 Mounting the measuring device . . . . .	16
6.3 Post-mounting check . . . . .	18
<b>7 Electrical connection</b> . . . . .	<b>20</b>
7.1 Connection conditions . . . . .	20
7.2 Connecting the measuring device . . . . .	21
7.3 Ensuring the degree of protection . . . . .	22
7.4 Post-connection check . . . . .	23
<b>8 Operation options</b> . . . . .	<b>24</b>
8.1 Structure and function of the operating menu . . . . .	24
8.2 Access to the operating menu via the local display . . . . .	26
8.3 Access to the operating menu via the operating tool . . . . .	32
<b>9 Commissioning</b> . . . . .	<b>33</b>
9.1 Function check . . . . .	33
9.2 Switching on the measuring device . . . . .	33
9.3 Setting the operating language . . . . .	34
9.4 Configuring the measuring device . . . . .	34
9.5 Defining the tag name . . . . .	35
9.6 Protecting settings from unauthorized access . . . . .	36
<b>10 Diagnostic information and remedial measures</b> . . . . .	<b>37</b>





# 1 Document information

## 1.1 Document conventions





### 1.1.1 Safety symbols

Symbol	Meaning
 A0011189-EN	<b>DANGER!</b> This symbol alerts you to a dangerous situation. Failure to avoid this situation will result in serious or fatal injury.
 A0011190-EN	<b>WARNING!</b> This symbol alerts you to a dangerous situation. Failure to avoid this situation can result in serious or fatal injury.
 A0011191-EN	<b>CAUTION!</b> This symbol alerts you to a dangerous situation. Failure to avoid this situation can result in minor or medium injury.
 A0011192-EN	<b>NOTICE!</b> This symbol contains information on procedures and other facts which do not result in personal injury.









### 1.1.2 Electrical symbols

Symbol	Meaning
 A0011197	<b>Direct current</b> A terminal to which DC voltage is applied or through which direct current flows.
 A0011198	<b>Alternating current</b> A terminal to which alternating voltage (sine-wave) is applied or through which alternating current flows.
 A0011200	<b>Ground connection</b> A grounded terminal which, as far as the operator is concerned, is grounded via a grounding system.
 A0011199	<b>Protective ground connection</b> A terminal which must be connected to ground prior to establishing any other connections.
 A0011201	<b>Equipotential connection</b> A connection that has to be connected to the plant grounding system: This may be a potential equalization line or a star grounding system depending on national or company codes of practice.





### 1.1.3 Tool symbols

 A0011219	 A0011220	 A0011221	 A0011222
Phillips head screwdriver	Flat blade screwdriver	Allen key	Hexagon wrench

### 1.1.4 Symbols for certain types of information

Symbol	Meaning
 A0011182	<b>Allowed</b> Indicates procedures, processes or actions that are allowed.
 A0011183	<b>Preferred</b> Indicates procedures, processes or actions that are preferred.
 A0011184	<b>Forbidden</b> Indicates procedures, processes or actions that are forbidden.
 A0011193	<b>Tip</b> Indicates additional information.
 A0011194	<b>Reference to documentation</b> Refers to the corresponding device documentation.
 A0011195	<b>Reference to page</b> Refers to the corresponding page number.
 A0011196	<b>Reference to graphic</b> Refers to the corresponding graphic number and page number.
	<b>Series of steps</b>
	<b>Result of a sequence of actions</b>

### 1.1.5 Symbols in graphics

Symbol	Meaning
1, 2, 3,...	Item numbers
	Series of steps
A, B, C, ...	Views
A-A, B-B, C-C, ...	Sections
 A0013441	Flow direction
 A0011187	<b>Hazardous area</b> Indicates a hazardous area.
 A0011188	<b>Safe area (non-hazardous area)</b> Indicates a non-hazardous location.

## 2 Basic safety instructions

### 2.1 Requirements for the personnel

The personnel must fulfill the following requirements for its tasks:

- ▶ Trained, qualified specialists must have a relevant qualification for this specific function and task
- ▶ Are authorized by the plant owner/operator
- ▶ Are familiar with federal/national regulations
- ▶ Before beginning work, the specialist staff must have read and understood the instructions in the Operating Instructions and supplementary documentation as well as in the certificates (depending on the application)
- ▶ Following instructions and basic conditions

### 2.2 Designated use

#### Application and media

The measuring device described in these Instructions is intended only for flow measurement of gases.

To ensure that the measuring device remains in proper condition for the operation time:

- ▶ Only use the measuring device in full compliance with the data on the nameplate and the general conditions listed in the Operating Instructions and supplementary documentation.
- ▶ Based on the nameplate, check whether the ordered device is permitted for the intended use in the hazardous area (e.g. explosion protection, pressure vessel safety).
- ▶ Use the measuring device only for media against which the process-wetted materials are adequately resistant.

#### Incorrect use

The manufacturer is not liable for damage caused by improper or non-designated use.

If the sensor gland is opened, the accuracy specifications of the measuring device no longer apply. In such situations, the measuring device must be removed and returned for recalibration and to the manufacturer.

#### **WARNING**

**Risk of injury if the process connection and sensor gland are opened under pressure.**

- ▶ The process connection and the sensor gland should only be opened in an unpressurized state.

#### **NOTICE**

**Dust and moisture can enter the transmitter when the transmitter housing is opened.**

- ▶ Only open the transmitter housing briefly, ensuring that no dust or moisture enters the housing.

#### **NOTICE**

**Danger of breakage of the sensor due to corrosive or abrasive fluids!**

- ▶ Verify the compatibility of the process fluid with the sensor material.
- ▶ Ensure the resistance of all fluid-wetted materials in the process.
- ▶ Observe the specified maximum process pressure.

Verification for borderline cases:

- ▶ For special fluids and fluids for cleaning, Endress+Hauser is glad to provide assistance in verifying the corrosion resistance of fluid-wetted materials, but does not accept any warranty or liability.

### **Residual risks**

The external surface temperature of the housing can increase by max. 15 K due to the power consumption of the electronic components. Hot process fluids passing through the measuring device will further increase the surface temperature of the housing. The surface of the sensor, in particular, can reach temperatures which are close to the fluid temperature.

Possible burn hazard due to fluid temperatures!

- ▶ For elevated fluid temperature, ensure protection against contact to prevent burns.

## **2.3 Workplace safety**

For work on and with the device:

- ▶ Wear the required personal protective equipment according to federal/national regulations.

For welding work on the piping:

- ▶ Do not ground the welding unit via the measuring device.

## **2.4 Operational safety**

Risk of injury.

- ▶ Operate the device in proper technical condition and fail-safe condition only.
- ▶ The operator is responsible for interference-free operation of the device.

## **2.5 Product safety**

This measuring device is designed in accordance with good engineering practice to meet state-of-the-art safety requirements, has been tested, and left the factory in a condition in which they are safe to operate.

It meets general safety standards and legal requirements. It also complies with the EC directives listed in the device-specific EC Declaration of Conformity. Endress+Hauser confirms this by affixing the CE mark to the device.

## 3 Product description

### 3.1 Product design

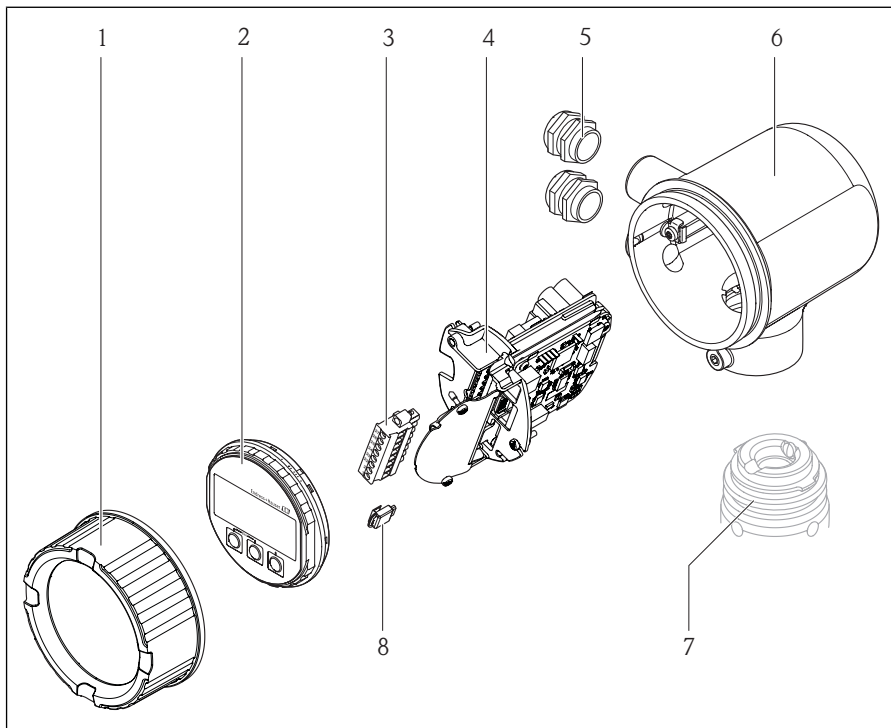

A0017196

- 1 Electronics compartment cover
- 2 Display module
- 3 Terminal block
- 4 Electronics module
- 5 Cable gland
- 6 Transmitter housing
- 7 Sensor
- 8 S-DAT

# 4 Incoming acceptance and product identification

## 4.1 Incoming acceptance



A0015502

1  
+  
2

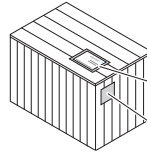

1  
+  
2

A0013843

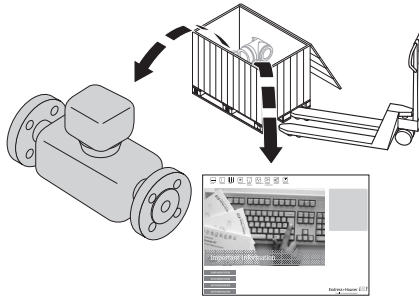

A0013695



A0015502

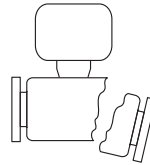
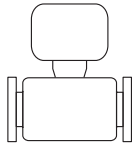

A0013698



A0015502

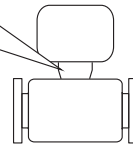
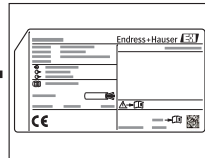

A0013699



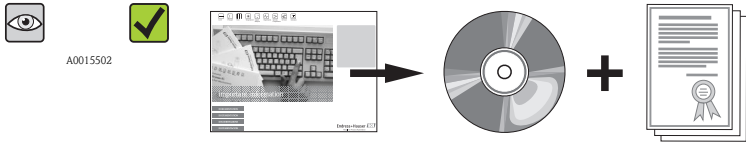

A0013697

**i** If one of the conditions does not comply, contact your Endress+Hauser distributor.

### 4.2 Product identification

The following options are available for identification of the measuring device:

- Nameplate specifications
- Order code with breakdown of the device features on the delivery note
- Enter serial numbers from nameplates in *W@M Device Viewer* ([www.endress.com/deviceviewer](http://www.endress.com/deviceviewer)): All information about the measuring device is displayed.

For an overview of the scope of the Technical Documentation provided, refer to the following: The *W@M Device Viewer*: Enter the serial number from the nameplate ([www.endress.com/deviceviewer](http://www.endress.com/deviceviewer))

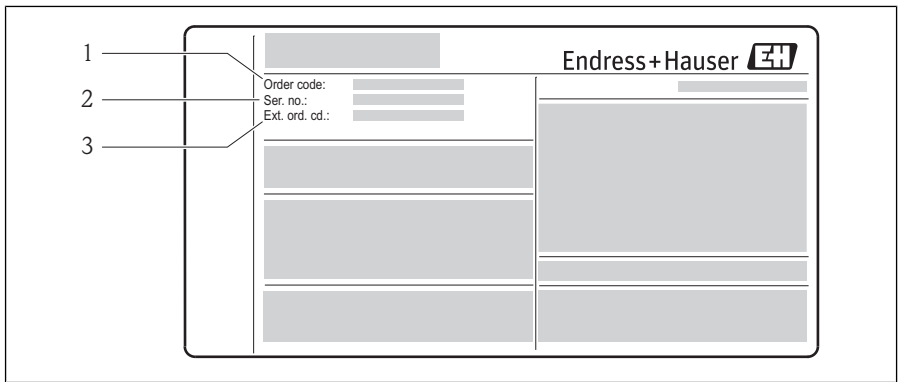

A0014053

**i** 1 Example of a nameplate

- 1 Order code
- 2 Serial number (Ser. no.)
- 3 Extended order code (Ext. ord. cd.)

**b** For detailed information about interpreting the nameplate specifications, refer to the Operating Instructions for the device on the CD-ROM provided

## 5 Storage and transport

### 5.1 Storage conditions

Observe the following notes for storage:

- Store in original packaging.
- Do not remove the protection cap mounted on the transducer.
- Protect from direct sunlight.
- Select a storage location where moisture cannot collect in the measuring device.
- Store in a dry and dust-free place.
- Do not store outdoors.
- Storage temperature(→  15)

### 5.2 Transporting the product

Observe the following notes during transport:

- Transport the measuring device to the measuring point in the original packaging.
- Do not remove the protection cap mounted on the transducer. It prevents mechanical damage and contamination.

### 5.3 Packaging disposal



For detailed information about disposing of the packaging materials, refer to the Operating Instructions for the device on the CD-ROM provided

## 6 Installation

### 6.1 Installation conditions

For mechanical reasons and to protect the pipe, support is recommended for heavy sensors (e.g. with a hot-tap retractable assembly).

#### 6.1.1 Mounting position

##### Orientation

The direction of the arrow on the sensor helps you to install the sensor according to the flow direction.

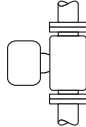
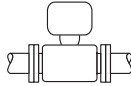
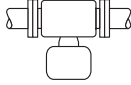
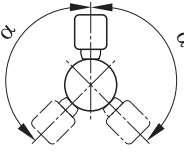
	Orientation	Recommendation
Vertical orientation	 A0017337	<input checked="" type="checkbox"/> 1) 2)
Horizontal orientation, transmitter head up	 A0015589	<input checked="" type="checkbox"/> <input checked="" type="checkbox"/>
Horizontal orientation, transmitter head down	 A0015590	<input checked="" type="checkbox"/> <input checked="" type="checkbox"/> 3)
Inclined mounting position, transmitter head down	 A0015773	<input checked="" type="checkbox"/> 4)

- 1) In the case of saturated or unclean gases, upward flow in a vertical pipe section is preferred to minimize condensation or contamination.
- 2) Not recommended in the case of extreme vibrations or unstable installations.
- 3) Suitable only for clean and dry gases. If buildup or condensate are always present: Mount the sensor in an inclined position.
- 4) Select inclined mounting position ( $\alpha = \text{approx. } 135^\circ$ ) if the gas is very wet or saturated with water.

##### Requirement for pipework

The measuring device must be professionally installed, and the following points must be observed:

Further information → ISO standard 14511

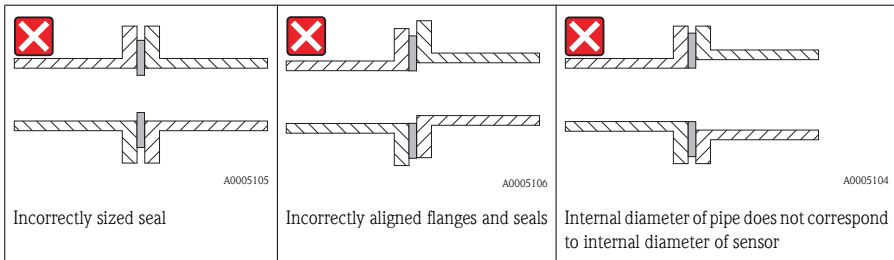
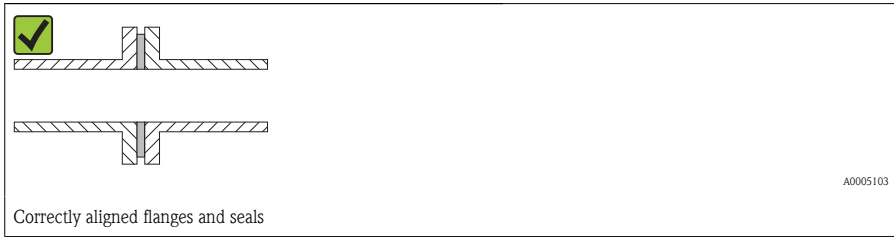

### Choosing the sensor length

- Determining the dimensions A, B, C1 and C2

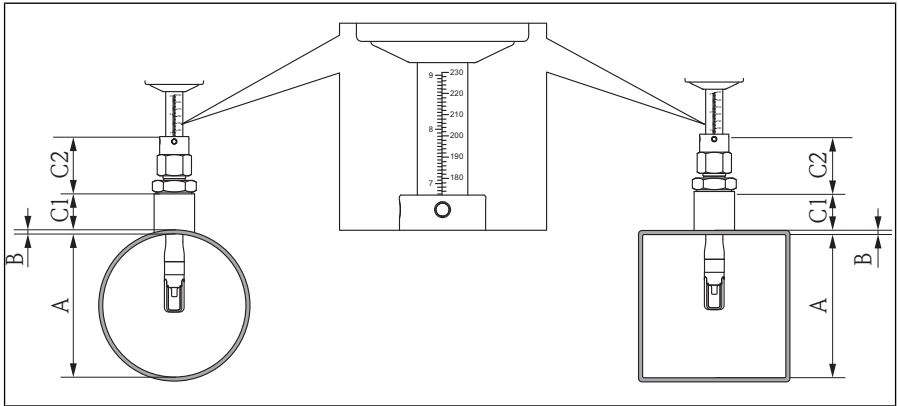

A0015768

- A Internal pipe diameter DN (circular pipe) or internal dimension (rectangular duct)
- B Thickness of pipe wall or of duct wall
- C1 Length of mounting set
- C2 Length of sensor compression fitting

*Determining C1 and C2 (Endress+Hauser original parts only)*

DK6MB-BXA mounting boss G1A	C1 + C2 = 99 mm (3.90 in)
DK6MB-DXA mounting boss G3/4A	C1 + C2 = 99 mm (3.90 in)
DK6MB-AXA mounting boss 1" NPT	C1 + C2 = 107 mm (4.21 in)
DK6MB-CXA mounting boss 3/4" NPT	C1 + C2 = 102 mm (4.02 in)

*Determining C1 and C2 (not limited to Endress+Hauser original parts)*

C1	Length of pipe connection used
C2 (compression fitting with G1A thread)	39 mm (1.54 in)
C2 (compression fitting with G3/4A thread)	39 mm (1.54 in)
C2 (compression fitting with 1" NPT thread)	47 mm (1.85 in)
C2 (compression fitting with 3/4" NPT thread)	42 mm (1.65 in)

► Calculating insertion depth

$$(0.3 \cdot A) + B + (C1 + C2)$$

**Mounting conditions for mounting boss**

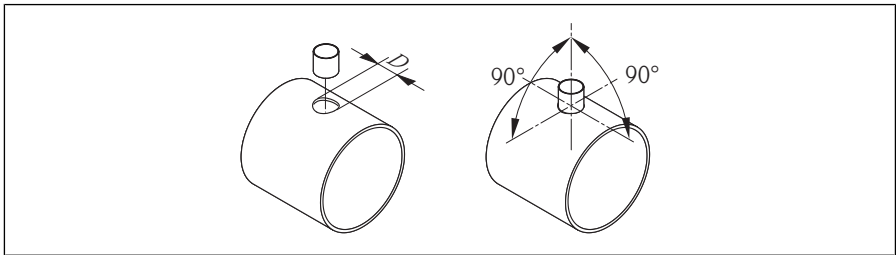

A0011843

$D = 31.0\text{ mm} \pm 0.05\text{ mm} (1.22\text{ in} \pm 0.02\text{ in})$

- ▶ When installing in rectangular ducts with thin walls:
  - ✓ Use suitable support brackets.

**Align the insertion version with the direction of flow.**

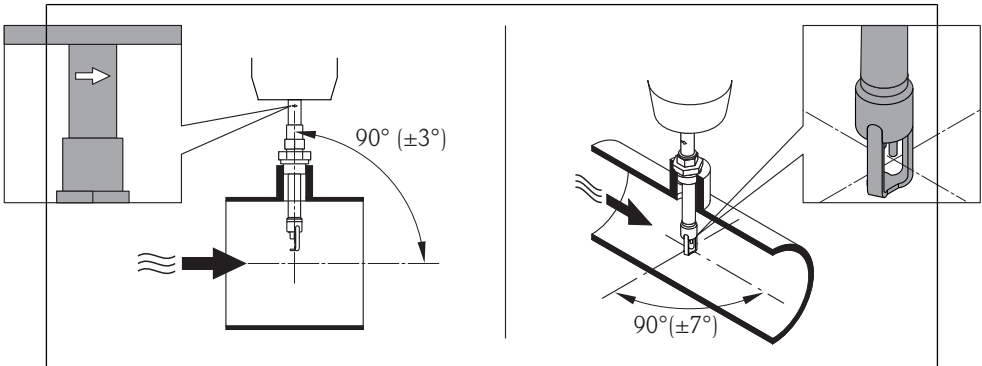

A0015746

Check and ensure that the sensor on the pipe/duct is aligned at a 90° angle to the direction of flow. Rotate the sensor so that the arrow marking on the sensor body corresponds to the direction of flow. The line marking on the body used to adjust the insertion depth must be aligned with the direction of flow.

**Inlet and outlet runs**

 For the dimensions and installation lengths of the device, see the "Technical Information" document, "Mechanical construction" section

### Recommended inlet and outlet runs

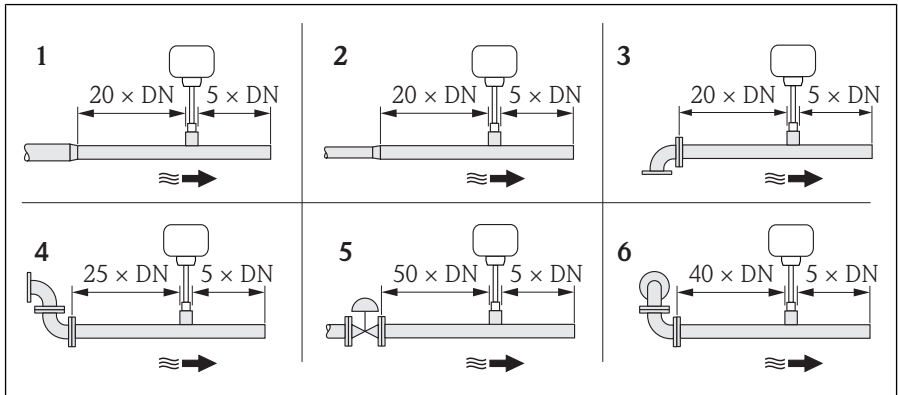

A0016943

- 1 reduction
- 2 expansion
- 3 90° elbow or T-piece
- 4 2 × 90° elbow
- 5 Control valve
- 6 2 × 90° elbow (3-dimensional)

### Outlet run for pressure or temperature transmitter

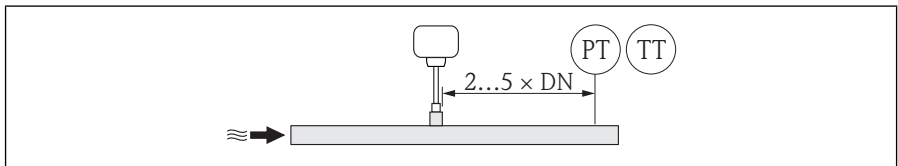

A0015603

- PT Pressure measuring device
- TT Temperature measuring device

### 6.1.2 Requirements from environment and process

#### Ambient temperature range

Measuring device	-40 to +60 °C (-40 to +140 °F)
Local display	-20 to +60 °C (-4 to +140 °F), the readability of the display may be impaired at temperatures outside the temperature range.

- ▶ If operating outdoors:

Avoid direct sunlight, particularly in warm climatic regions.

## System pressure

### Sensor

Depending on the version, please note the details on the name plate .

Max. 20 bar g (290 psi g)

## Thermal insulation

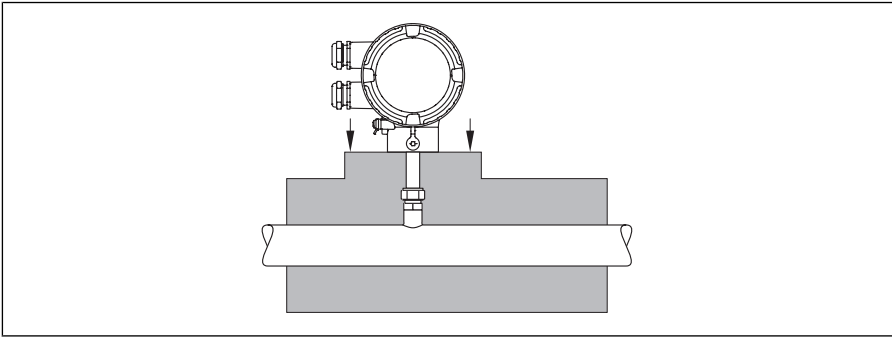

A0015763

## 6.2 Mounting the measuring device

### 6.2.1 Required tools

#### For transmitter

For turning the transmitter housing (in increments of 90°): Allen screw 4 mm (0.15 in)

#### For sensor

For the sensor gland: Corresponding mounting tools

### 6.2.2 Preparing the measuring device

1. Remove all remaining transport packaging.
2. Remove the protective cap from the sensor.
3. Remove stick-on label on the electronics compartment cover.

### 6.2.3 Mounting the measuring device

#### **⚠ WARNING**

#### **Danger due to improper process sealing!**

- ▶ Ensure that the gaskets are clean and undamaged (G 1 A, G ¾ A).
- ▶ Ensure that the correct sealing material has been used (e.g. Teflon tape for NPT 1", NPT ¾").
- ▶ Install the gaskets correctly.



1. Ensure that the direction of the arrow on the sensor matches the flow direction of the medium.
- 2.

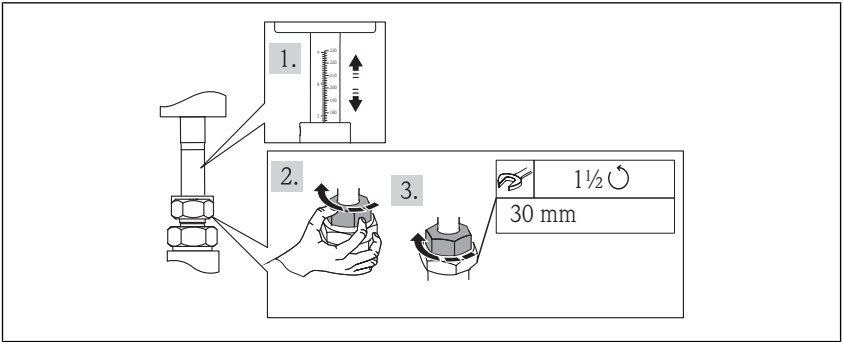

A0017331

Ensure the insertion depth and alignment are correct. Thread adapter nut: when mounting for the first time, tighten it fingertight + 1 1/2 turns. For all other mounting routines, tighten it fingertight and 1 additional turn

3. Install the measuring device or turn the transmitter housing so that the cable entries do not point upwards.

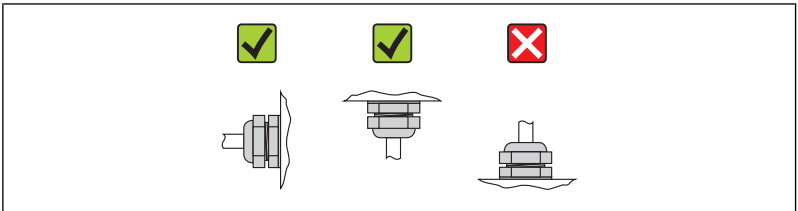

A0013964

### 6.2.4 Turning the transmitter housing

To provide easier access to the connection compartment or display module, the transmitter housing can be turned clockwise or counterclockwise to 4 indexed positions by a maximum of 2 x 90°:

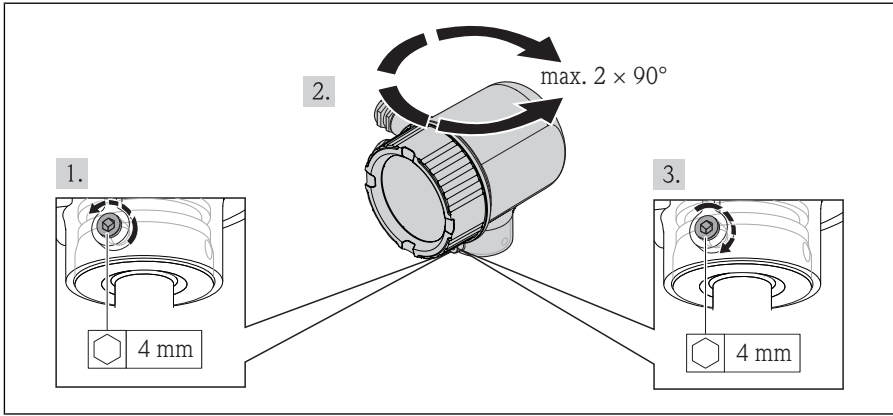

A0017227

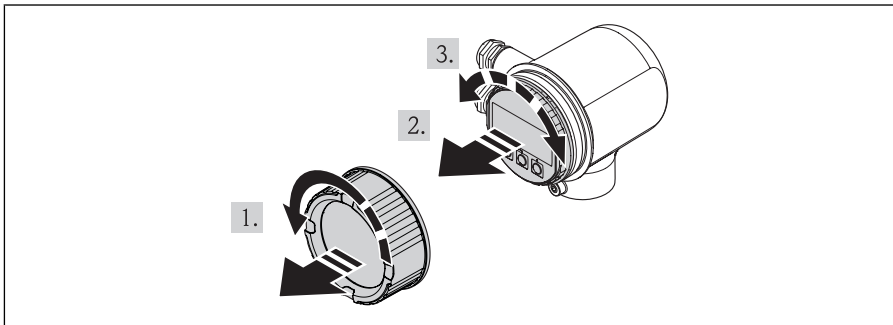

### 6.2.5 Turning the display module



A0017228

### 6.3 Post-mounting check

<p>Is the device damaged (visual inspection)?</p>	<p><input type="checkbox"/></p>
<p>Does the measuring device conform to the measuring point specifications?</p> <p>For example:</p> <ul style="list-style-type: none"> <li>■ Process temperature</li> <li>■ Process pressure (refer to the chapter on "Material load curves" of the "Technical Information" document on the CD-ROM provided)</li> <li>■ Ambient temperature range (→ 15)</li> <li>■ Measuring range</li> </ul>	<p><input type="checkbox"/></p>

Has the correct orientation for the sensor been selected (→  11)?	<input type="checkbox"/>
<ul style="list-style-type: none"> <li>■ According to sensor type</li> <li>■ According to medium properties</li> <li>■ According to medium temperature</li> <li>■ According to process pressure</li> </ul>	
Does the arrow on the sensor match the direction of flow of the medium through the piping (→  11)?	<input type="checkbox"/>
Have sufficient inlet and outlet runs been provided upstream and downstream of the measuring point?	<input type="checkbox"/>
Correctly aligned in the direction of flow?	<input type="checkbox"/>
Correct sensor immersion depth?	<input type="checkbox"/>
Is the device adequately protected from precipitation and direct sunlight?	<input type="checkbox"/>
Is the device protected against overheating?	<input type="checkbox"/>
Is the device protected against excessive vibrations?	<input type="checkbox"/>
Check gas property (e.g. purity, dryness, cleanness).	<input type="checkbox"/>
Are the measuring point identification and labeling correct (visual inspection)?	<input type="checkbox"/>

## 7 Electrical connection

### 7.1 Connection conditions

#### 7.1.1 Required tools

- For cable entries: Use corresponding tools
- Wire stripper
- When using stranded cables: Crimping tool for wire end ferrule
- Flat blade screwdriver ≤ 3 mm (0.12 in)

#### 7.1.2 Requirements for connecting cable

The connecting cables provided by the customer must fulfill the following requirements.

#### Electrical safety

In accordance with applicable federal/national regulations.

#### Cable specification

Permitted temperature range:

- -40 °C (-40 °F)...≥ 80 °C (176 °F)
- Minimum requirement for cable temperature range: ambient temperature +20 K

Current output

For 4-20 mA HART: Shielded cable recommended. Observe grounding concept of the plant.

Pulse/frequency/switching output

Standard installation cable is sufficient

Cable diameter

- Included cable glands: M20 × 1.5 with cable Ø 6 to 12 mm (0.24 to 0.47 in)
- Core cross-sections 0.5 to 1.5 mm<sup>2</sup> (21 to 16 AWG)

#### 7.1.3 Requirements for the supply unit

#### Device supply voltage

DC 24 V (18 to 30 V)

The power supply circuit must comply with SELV/PELV requirements.

#### Pulse/frequency/status supply voltage

An external power supply is required for each output.

Order characteristic for "Output"	Maximum terminal voltage
Option B, K	DC 30 V

#### Load

0 to 750 Ω, depending on the external supply voltage of the power supply unit

### 7.1.4 Terminal assignment

The terminal assignment for the electrical connection can be found on the nameplate of the electronics module.

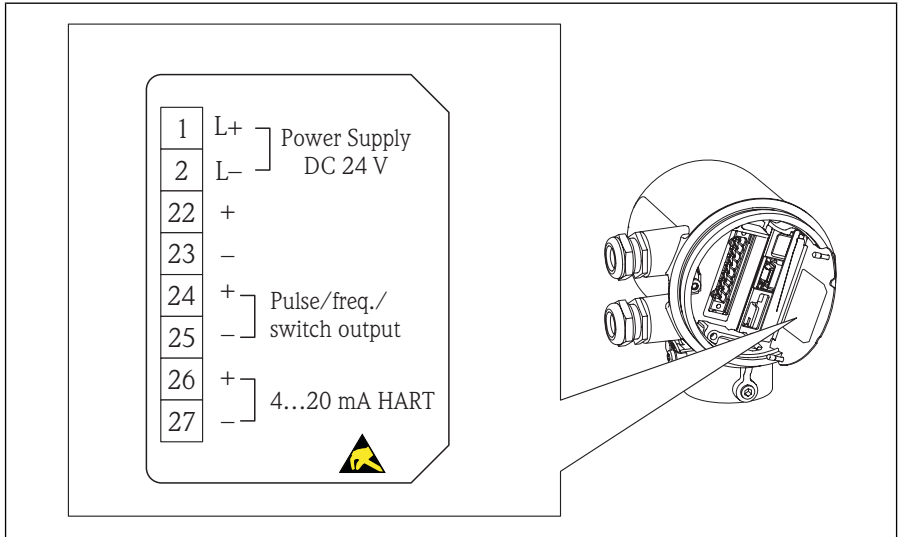

A0017222

### 7.1.5 Preparing the measuring device

1. Remove dummy plug if present.
2. **NOTICE!** Insufficient sealing of the housing. Operational reliability of the measuring device could be defeated. Use suitable cable glands corresponding to the degree of protection.  
If measuring device is delivered without cable glands:  
Provide suitable cable gland for corresponding connecting cable. (→ 20)
3. If measuring device is delivered with cable glands:  
Observe cable specification (→ 20).

## 7.2 Connecting the measuring device

### NOTICE

#### Limitation of electrical safety due to incorrect connection!

- ▶ SELV/PELV-compliant 24 V DC (18 to 30 V) power supply.
- ▶ 4 to 20 mA HART active
- ▶ Maximum output values: DC 24V, 22 mA, load 0 to 750 Ω

### 7.2.1 Connecting the cables

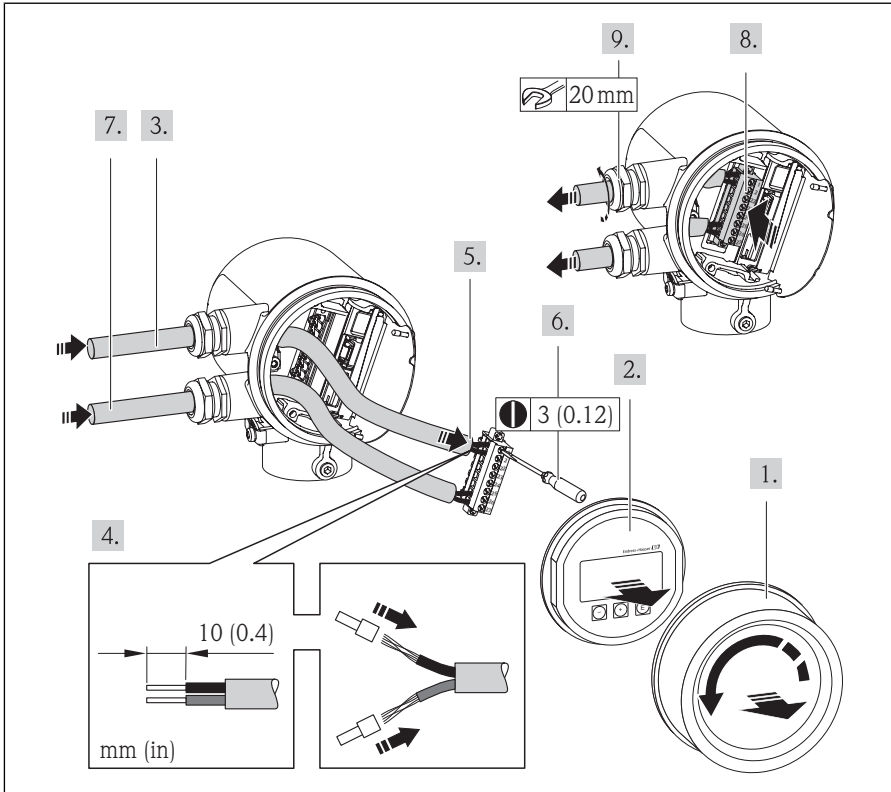

A0017250

- ▶ **NOTICE!** Housing degree of protection voided due to insufficient sealing of the housing. Screw in the thread without using any lubricant. The threads on the cover are coated with a dry lubricant.  
Reverse the removal procedure to reassemble the transmitter.

- i** For HART communication: When connecting the cable shielding to the ground terminal, observe the grounding concept of the facility.

### 7.3 Ensuring the degree of protection

The measuring device fulfills all the requirements for the IP66 and IP67 (Type 4X enclosure) degree of protection.

To guarantee IP 66 and IP 67 degree of protection (Type 4X enclosure), carry out the following steps after the electrical connection:

1. Check whether the housing seals of the connection and electronics compartment are clean and inserted correctly. Dry, clean or replace the seals if necessary.

2. Tighten all housing screws and screw covers.
3. Firmly tighten the cable glands.
4. To ensure that moisture does not enter the cable entry, route the cable so that it loops down before the cable entry ("water trap").

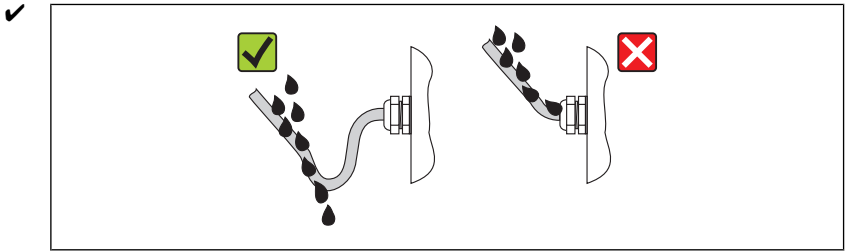

A0013960

5. Insert dummy plugs into unused cable entries.

## 7.4 Post-connection check

Are cables or the device undamaged (visual inspection)?	<input type="checkbox"/>
Are the power supply and signal cables correctly connected?	<input type="checkbox"/>
Does the supply voltage correspond to the specifications in the connection diagram?	<input type="checkbox"/>
Do the cables comply with the requirements (→ 20)?	<input type="checkbox"/>
Do the cables have adequate strain relief? Are they routed securely?	<input type="checkbox"/>
Is the cable route completely isolated? Without loops and cross-overs?	<input type="checkbox"/>
Are all the screw terminals firmly tightened?	<input type="checkbox"/>
Are all the cable glands installed, firmly tightened and leak-tight? Cable run with "water trap" (→ 20) ?	<input type="checkbox"/>
Does the supply voltage match the specifications on the transmitter nameplate (→ 20)?	<input type="checkbox"/>
Is the terminal assignment correct (→ 20)?	<input type="checkbox"/>
If supply voltage is present, is the device ready for operation and do values appear on the display module?	<input type="checkbox"/>
Are all housing covers installed and firmly tightened?	<input type="checkbox"/>

# 8 Operation options

## 8.1 Structure and function of the operating menu

### 8.1.1 Structure of the operating menu

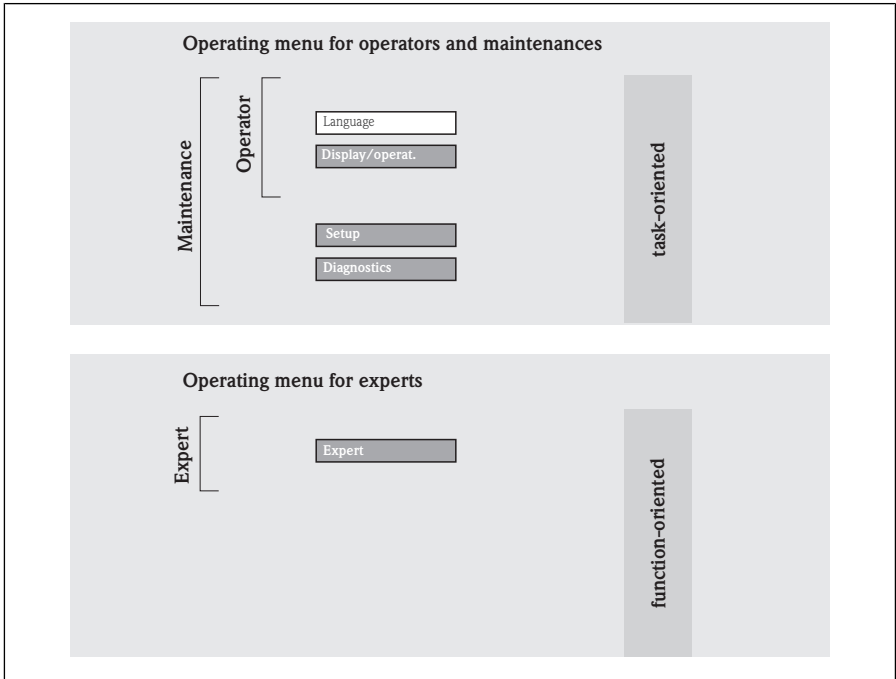

A0014058-EN



### **8.1.2 Operating philosophy**

The individual parts of the operating menu are assigned to certain user roles. Each user role contains typical tasks within the device lifecycle.



For detailed information about the operating philosophy of the instrument, refer to the Operating Instructions for the device on the CD-ROM provided

## 8.2 Access to the operating menu via the local display

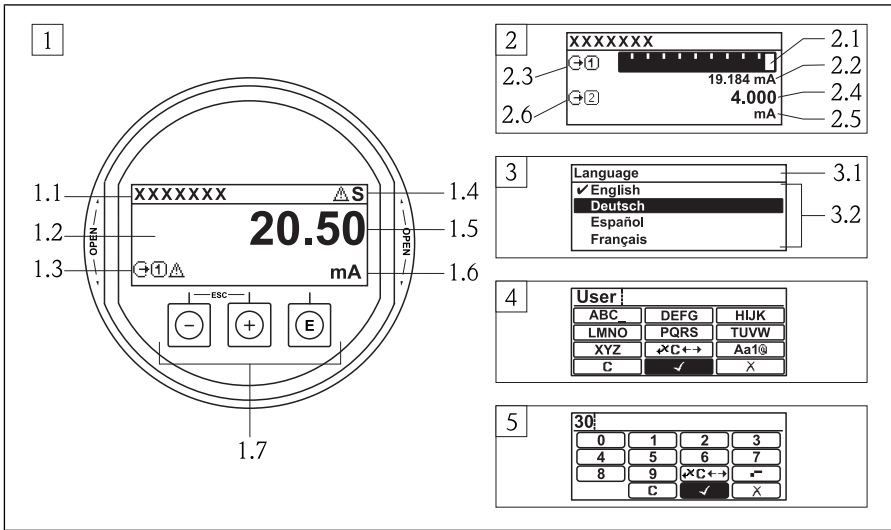





A0014013

- 1 Operational display with measured value shown as "1 value, max." (example)
  - 1.1 Device tag
  - 1.2 Display area for measured values (4-line)
  - 1.3 Explanatory symbols for the measured value: measured value type, measuring channel number, symbol for event behavior
  - 1.4 Status area
  - 1.5 Measured value
  - 1.6 Unit for the measured value
  - 1.7 Operating elements
- 2 Operational display with measured value shown as "1 bar graph + 1 value" (example)
  - 2.1 Bar graph display for measured value 1
  - 2.2 Measured value 1 with unit
  - 2.3 Explanatory symbols for measured value 1: measured value type, measuring channel number
  - 2.4 Measured value 2
  - 2.5 Unit for measured value 2
  - 2.6 Explanatory symbols for measured value 2: measured value type, measuring channel number
- 3 Navigation view: picklist of a parameter
  - 3.1 Navigation path and status area
  - 3.2 Display area for navigation: ✓ designates the current parameter value
- 4 Editing view: text editor with input mask
- 5 Editing view: numeric editor with input mask







### 8.2.1 Operational display

#### Status area

Status signals			
<b>F</b> <small>A0013956</small>	<b>C</b> <small>A0013959</small>	<b>S</b> <small>A0013958</small>	<b>M</b> <small>A0013957</small>
Failure	Function check	Out of specification	Maintenance required
Diagnostic behavior		Locking	Communication
 <small>A0013961</small>	 <small>A0013962</small>	 <small>A0013963</small>	 <small>A0013965</small>
Alarm	Warning	Device locked	Remote operation enabled

#### Display area

##### Measured variables

Symbol	Meaning
 <small>A0013711</small>	Corrected volume flow, FAD
 <small>A0013710</small>	Mass flow
 <small>A0013947</small>	Temperature
 <small>A0013943</small>	Totalizer
 <small>A0013945</small>	Current output
Symbols for measurement channel numbers	
 <small>A0016325</small>	Measurement channel 1 to 4
The measurement channel number is displayed only if more than one channel is present for the same measured variable type.	
Symbols for diagnostic behavior	
The diagnostic behavior pertains to a diagnostic event that is relevant to the displayed measured variable. For more information about the symbols, refer to the "Status area" section (→ <a href="#">27</a> ).	









### 8.2.2 Navigation view

#### Status area

The following appears in the status area of the navigation view in the top right corner:

















- Of the submenu
  - The direct access code for the parameter you are navigating to (e.g. 0022-1)
  - If a diagnostic event is present, the diagnostic behavior and status signal
- In the wizard
  - If a diagnostic event is present, the diagnostic behavior and status signal

## Display area





Icons for menus			
 A0013973	 A0013974	 A0013975	 A0013966
Display/operat.	Setup	Diagnostics	Expert
Icons for submenus, wizards, parameters			Lock symbols
 A0013967	 A0013968	 A0013972	 A0013963
Submenu	Wizard	Parameters within a wizard	Parameter locked



### 8.2.3 Editing view

#### Input mask

Operating symbols in the numeric editor			
 A0013985	 A0016621	 A0013986	
Confirms selection.	Moves the input position one position to the left.	Exits the input without applying the changes.	
 A0016619	 A0016620	 A0014040	
Inserts decimal separator at the input position.	Inserts minus sign at the input position.	Clears all entered characters.	
Operating symbols in the text editor			
 A0013985	 A0013987	 A0013986	
Confirms selection.	Switches to the selection of the correction tools.	Exits the input without applying the changes.	
 A0014040	 A0013981		
Clears all entered characters.	Toggle <ul style="list-style-type: none"> <li>■ Between upper-case and lower-case letters</li> <li>■ For entering numbers</li> <li>■ For entering special characters</li> </ul>		
Correction symbols under 			
 A0013989	 A0013990	 A0013991	 A0013988
Clears all entered characters.	Moves the input position one position to the left.	Moves the input position one position to the right.	Deletes one character immediately to the left of the input position.

## 8.2.4 Operating elements

Key	Meaning
 A001.3969	<p><b>Minus key</b></p> <p><i>In a menu, submenu</i>            Moves the selection bar upwards in a choose list.</p> <p><i>With a Wizard</i>            Confirms the parameter value and goes to the previous parameter.</p> <p><i>With a text and numeric editor</i>            In the input mask, moves the selection bar to the left (backwards).</p>
 A001.3970	<p><b>Plus key</b></p> <p><i>In a menu, submenu</i>            Moves the selection bar downwards in a choose list.</p> <p><i>With a Wizard</i>            Confirms the parameter value and goes to the next parameter.</p> <p><i>With a text and numeric editor</i>            Moves the selection bar to the right (forwards) in an input screen.</p>
 A001.3952	<p><b>Enter key</b></p> <p><i>For operational display</i></p> <ul style="list-style-type: none"> <li>■ Pressing the key briefly opens the operating menu.</li> <li>■ Pressing the key for 2 s opens the context menu.</li> </ul> <p><i>In a menu, submenu</i></p> <ul style="list-style-type: none"> <li>■ Pressing the key briefly:           <ul style="list-style-type: none"> <li>– Opens the selected menu, submenu or parameter.</li> <li>– Starts the wizard.</li> <li>– If help text is open, closes the help text of the parameter.</li> </ul> </li> <li>■ Pressing the key for 2 s for parameter:           <ul style="list-style-type: none"> <li>– If present, opens the help text for the function of the parameter.</li> </ul> </li> </ul> <p><i>With a Wizard</i>            Opens the editing view of the parameter.</p> <p><i>With a text and numeric editor</i></p> <ul style="list-style-type: none"> <li>■ Pressing the key briefly:           <ul style="list-style-type: none"> <li>– Opens the selected group.</li> <li>– Carries out the selected action.</li> </ul> </li> <li>■ Pressing the key for 2 s confirms the edited parameter value.</li> </ul>
 A001.3971	<p><b>Escape key combination (press keys simultaneously)</b></p> <p><i>In a menu, submenu</i></p> <ul style="list-style-type: none"> <li>■ Pressing the key briefly:           <ul style="list-style-type: none"> <li>– Exits the current menu level and takes you to the next higher level.</li> <li>– If help text is open, closes the help text of the parameter.</li> </ul> </li> <li>■ Pressing the key for 2 s returns you to the operational display ("home position").</li> </ul> <p><i>With a Wizard</i>            Exits the wizard and takes you to the next higher level.</p> <p><i>With a text and numeric editor</i>            Closes the text or numeric editor without applying changes.</p>

Key	Meaning
 <small>A0013953</small>	<b>Minus/Enter key combination (press the keys simultaneously)</b> Reduces the contrast (brighter setting).
 <small>A0013954</small>	<b>Plus/Enter key combination (press and hold down the keys simultaneously)</b> Increases the contrast (darker setting).
 <small>A0013955</small>	<b>Minus/Plus/Enter key combination (press the keys simultaneously)</b> <i>For operational display</i> Enables or disables the keypad lock.

### 8.2.5 Opening the context menu

Using the context menu, the user can call up the following three menus quickly and directly from the measured value display:

- Setup
- Conf. backup disp.
- Simulation



#### Calling up and closing the context menu

The user is in the measured value display.

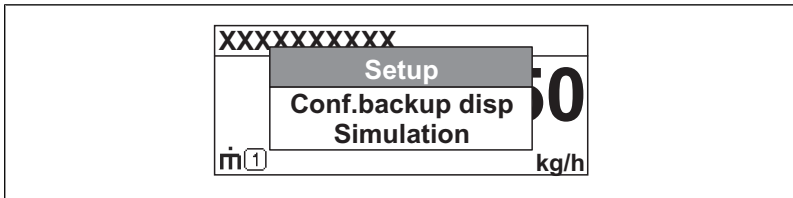

1. 2 s Press  for
  - ✓ The context menu opens.



A0014003-EN

2. Press  +  simultaneously.
  - ✓ The context menu is closed and the measured value display appears.

#### Calling up the menu via the context menu



1. Open the context menu.
2. Press  to navigate to the desired menu.
3. Press  to confirm the selection.
  - ✓ The selected menu opens.

### 8.2.6 Calling up help text

Help text is available for some parameters and can be called up from the navigation view. The help text provides a brief explanation of the parameter function and thereby supports swift and safe commissioning.

## Calling up and closing the help text

The user is in the navigation view and the selection bar is on a parameter.

1. 2 s Press  for
  - ✓ The help text for the selected parameter opens.
2. Press  +  simultaneously.
  - ✓ The help text is closed.

### 8.2.7 User roles and related access authorization

The two user roles "Operator" and "Maintenance" have different write access to the parameters if the customer defines a user-specific access code. This protects the device configuration via the local display from unauthorized access (→  36).

#### Access authorization to parameters

User role	Read access		Write access	
	Without access code (from the factory)	With access code	Without access code (from the factory)	With access code
Operator	✓	✓	✓	— <sup>1)</sup>
Maintenance	✓	✓	✓	✓

- 1) Despite the defined access code, certain parameters can always be modified and thus are exempted from the write protection, as they do not affect the measurement (e.g. "Format display").



For detailed information about parameters which can always be modified, refer to the Operating Instructions for the device on the CD-ROM provided

If an incorrect access code is entered, the user obtains the access rights of the "Operator" role.





The user role with which the user is currently logged on is indicated by the **Access status display** parameter. Navigation path: Display/operation → Access status display

### 8.2.8 Disabling write protection via access code

If the -symbol appears on the local display in front of a parameter, the parameter is write-protected by a user-specific access code and its value cannot be changed at the moment using the local display(→  36).

The locking of the write access via local operation can be disabled by entering the customer-defined access code via the respective access option.

1. After you press , the input prompt for the access code appears.
2. Enter the access code.
  - ✓ The -symbol in front of the parameters disappears; all previously write-protected parameters are now re-enabled.

### 8.2.9 Enabling and disabling the keypad lock

The keypad lock makes it possible to block access to the entire operating menu via local operation. As a result, it is no longer possible to navigate through the operating menu or change the values of individual parameters. Users can only read the measured values on the operational display.

The keypad lock is enabled and disabled in the same way:

The user is in the operational display.

- ▶ By simultaneously pressing the  $\square$  +  $\square$  +  $\square$  keys.
  - ✓ After enabling the keypad lock:

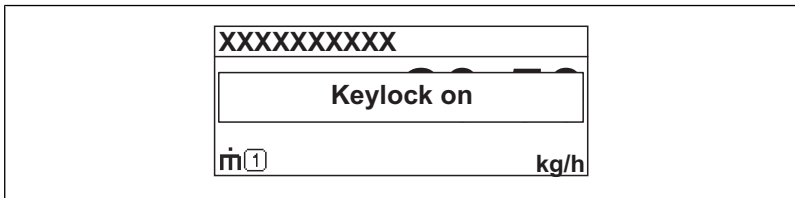

A0014000-EN

## 8.3 Access to the operating menu via the operating tool

 For detailed information about access to the operating menu via operating tool, refer to the Operating Instructions for the device on the CD-ROM provided

### 8.3.1 Via HART protocol

This communication interface is present in the following device version:

- Order characteristic for "Output", option **A**: 4-20 mA HART
- Order characteristic for "Output", option **B**: 4-20 mA HART, pulse/frequency/switching output



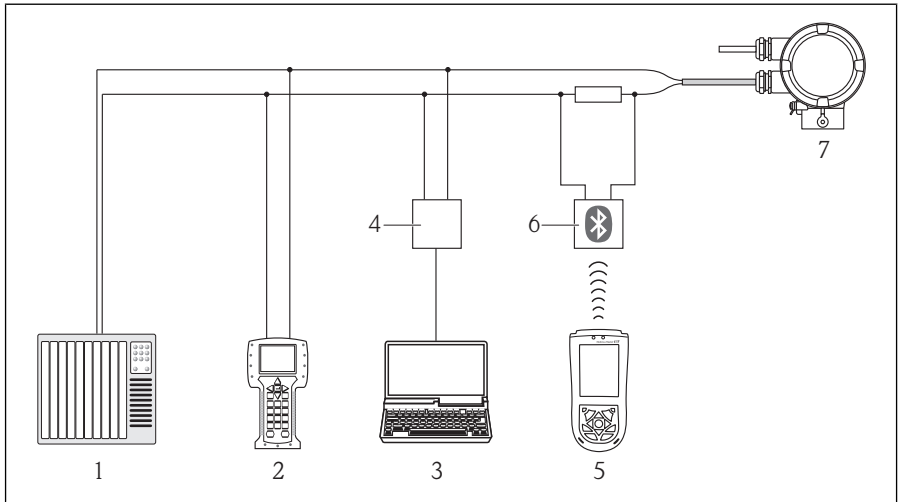

A0017373



## 2 Options for remote operation via HART protocol

- 1 Control system (e.g. PLC)
- 2 Field Communicator 475
- 3 Computer with operating tool (e.g. FieldCare, AMS Device Manager, SIMATIC PDM)
- 4 Commubox FXA195 (USB)
- 5 Field Xpert SFX100
- 6 VIATOR Bluetooth modem with connecting cable
- 7 Transmitter

## 9 Commissioning

### 9.1 Function check

Before commissioning the device, make sure that the post-installation and post-connection checks have been performed.

- "Post-mounting check" checklist (→  18)
- "Post-connection check" checklist (→  23)

### 9.2 Switching on the measuring device

After a successful function check, switch on the measuring device.

After a successful startup, the local display switches automatically from the startup display to the measured value display.

 If nothing appears on the local display or a diagnostic message is displayed, refer to the device's operating instructions which can be found on the CD-ROM supplied with the device.

### 9.3 Setting the operating language

Factory setting: English or ordered local language

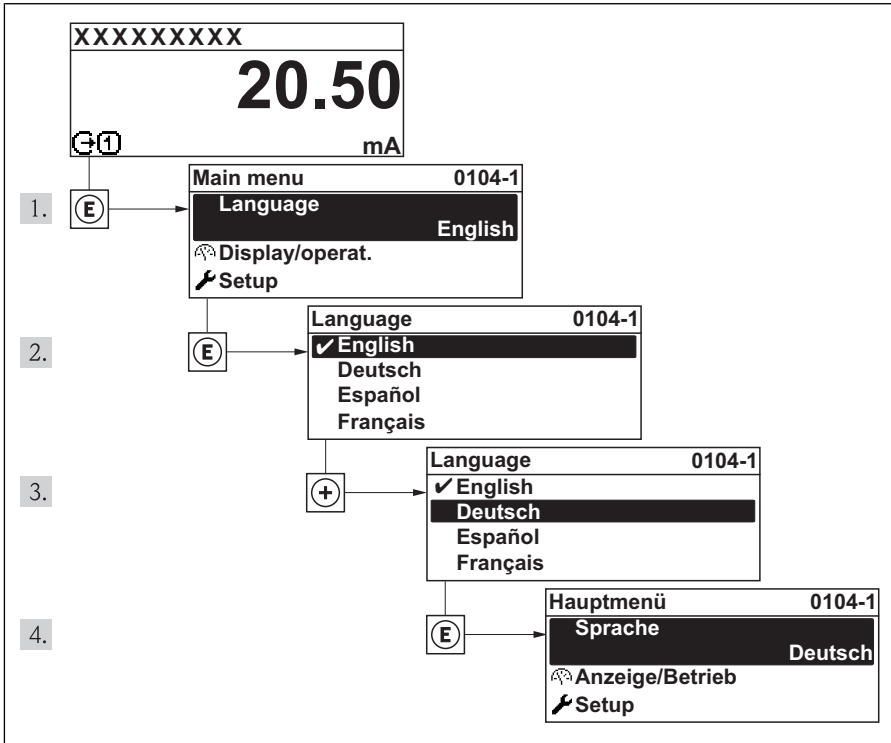

A0013996

### 9.4 Configuring the measuring device

The **Setup** menu and its guided wizards enable fast commissioning of the measuring device. The wizards guide you systematically through all parameters that are required for configuration, such as parameters for measurement, outputs and the local display.

*Overview of the "Setup" menu*

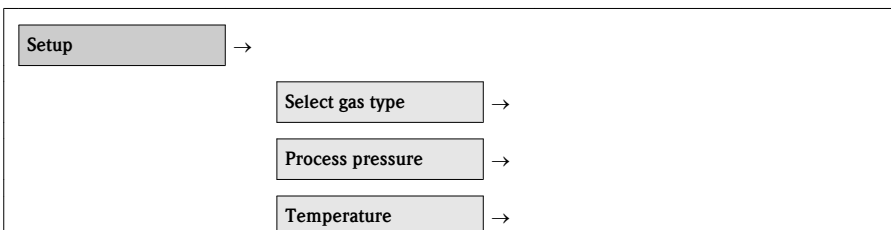

Pipe shape	→	
Pipe inner diameter	→	
Duct internal height	→	
Duct internal width	→	
Installation factor	→	
Assign current output	→	
4mA value	→	
20mA value	→	
Operating mode	→	
		Pulse
		Frequency
		Switching output

Options	Meaning
Select gas type	Define the gas type
Process pressure	Define the process pressure
Temperature	Display the current temperature
Pipe shape	Enter whether the pipe is circular or rectangular
Pipe inner diameter	If the pipe is circular, enter the internal diameter
Duct internal height	If the pipe is rectangular, enter the height
Duct internal width	If the pipe is rectangular, enter the width
Installation factor	Factor for correcting the mass flow
Current output	Select the current output assignment
4mA value	Define a measured variable for the 4mA value
20mA value	Define a measured variable for the 20mA value
Operating mode	Select the pulse/frequency/switch output

### 9.5 Defining the tag name

To enable fast identification of the measuring point within the system, you can enter a unique designation using the **Device tag** parameter and thus change the factory setting.

#### Navigation path

Setup → Advanced setup → Device tag



## User entry

Max. 32 characters, such as letters, numbers or special characters (e.g. @, %, /)

In the factory configuration, the tag name appears at the top left in the header.

## 9.6 Protecting settings from unauthorized access

The following options exist for protecting the configuration of the measuring device from unintentional modification after commissioning:

- Write protection via access code (→  36)
- Write protection via lock switch (→  36)
- Write protection via keypad lock (→  29)



### 9.6.1 Write protection via access code

Using the customer-specific access code, the parameters for the measuring device configuration are write-protected and their values can no longer be changed via local operation.

#### Define access code

1. Navigating to the "Define access code" parameter: Setup → Advanced setup → Def. access code
2. Define a max. 4-digit numeric code as an access code.
  - ✓ The -symbol appears in front of all write-protected parameters.

The device automatically locks the write-protected parameters again if a key is not pressed for 10 minutes in the navigation and editing view. The device locks the write-protected parameters automatically after 60 s if the user skips back to the measured value display mode from the navigation and editing view.

 If write access is activated via access code, it can be also be deactivated only via the access code (→  31).

### 9.6.2 Write protection via lock switch

Unlike write protection via user-specific access code, this allows write access to the entire operating menu - other than the **Contrast display** parameter - to be locked.

The values of the parameters are still visible, but can no longer be changed (except for **Contrast display**), either via the local display, the service interface (CDI) or HART protocol.

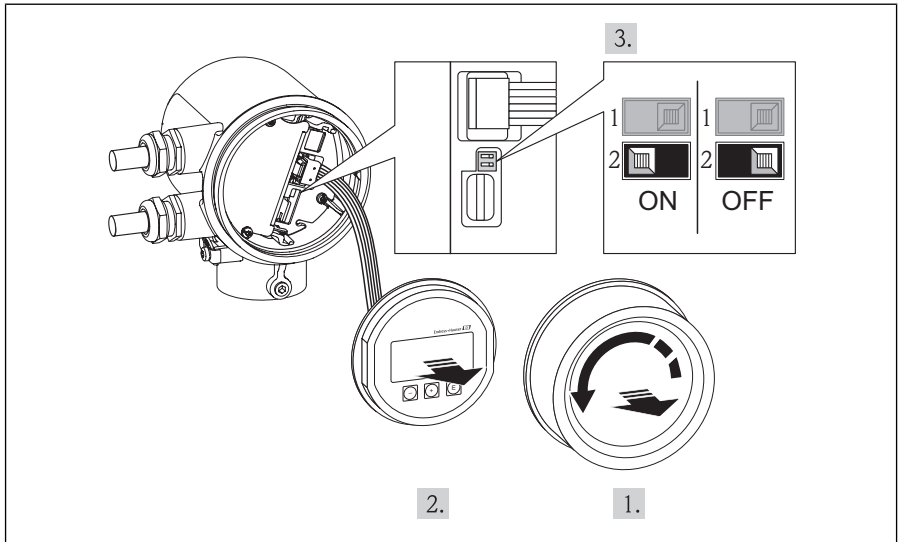

A0017255

1. Unscrew the electronics compartment cover.
2. Pull out the display module with a gentle rotational movement.
3. To make it easier to access the lock switch, attach the display module to the edge of the electronics compartment.
4. Setting the lock switch (WP) on the electronics module to the ON position enables the hardware write protection.
  - ✓ The  symbol appears in the header of the measured value display and in the navigation view in front of the parameters.
5. Feed the ribbon cable into the gap between the housing and electronics module and plug the display module into the electronics compartment in the desired direction until it engages.
6. Screw down the electronics compartment cover

## 10 Diagnostic information and remedial measures

Faults detected by the self-monitoring system of the measuring device are displayed as a diagnostic message in alternation with the operational display. The message on the remedial measures can be called up from the diagnostic message, and contains important information on the fault.

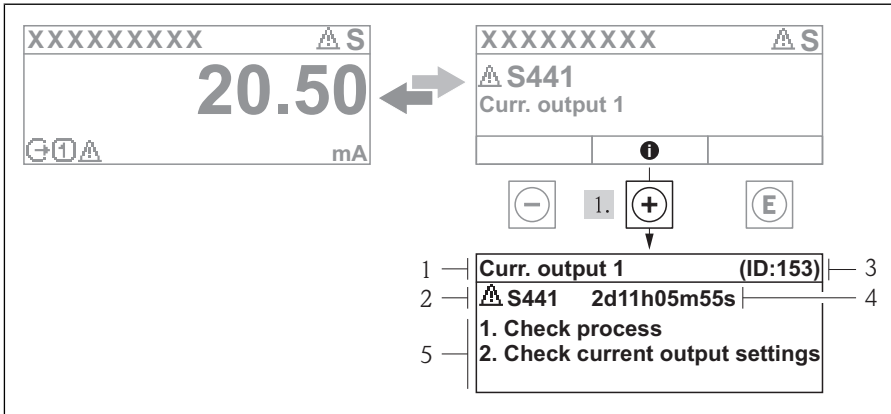

A0013940-EN

3 Message for remedial measures

- 1 Short text
- 2 Diagnostic behavior with diagnostic code
- 3 Service ID
- 4 Operation time of occurrence
- 5 Remedial measures

The user is in the diagnostic message.

1. Press **+** (**i** symbol).
  - ✓ The message for the remedial measures for the diagnostic event opens.
2. Press **-** + **+** simultaneously.
  - ✓ The message about the remedial measures closes.



[www.endress.com/worldwide](http://www.endress.com/worldwide)

---

**Endress+Hauser**   
People for Process Automation

---