

Brief Operating Instructions Prosonic S FMU95

Transmitter for 5 or 10 ultrasonic sensors

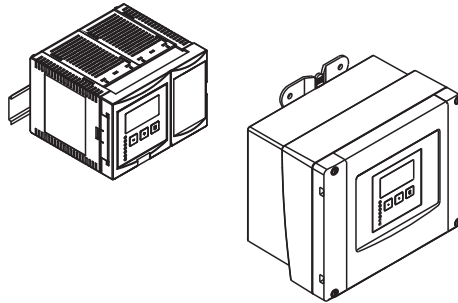

These Instructions are Brief Operating Instructions; they are not a substitute for the Operating Instructions pertaining to the device.

Detailed information about the device can be found in the Operating Instructions and the other documentation:

Available for all device versions via:

- Internet: www.endress.com/deviceviewer
- Smart phone/tablet: *Endress+Hauser Operations App*

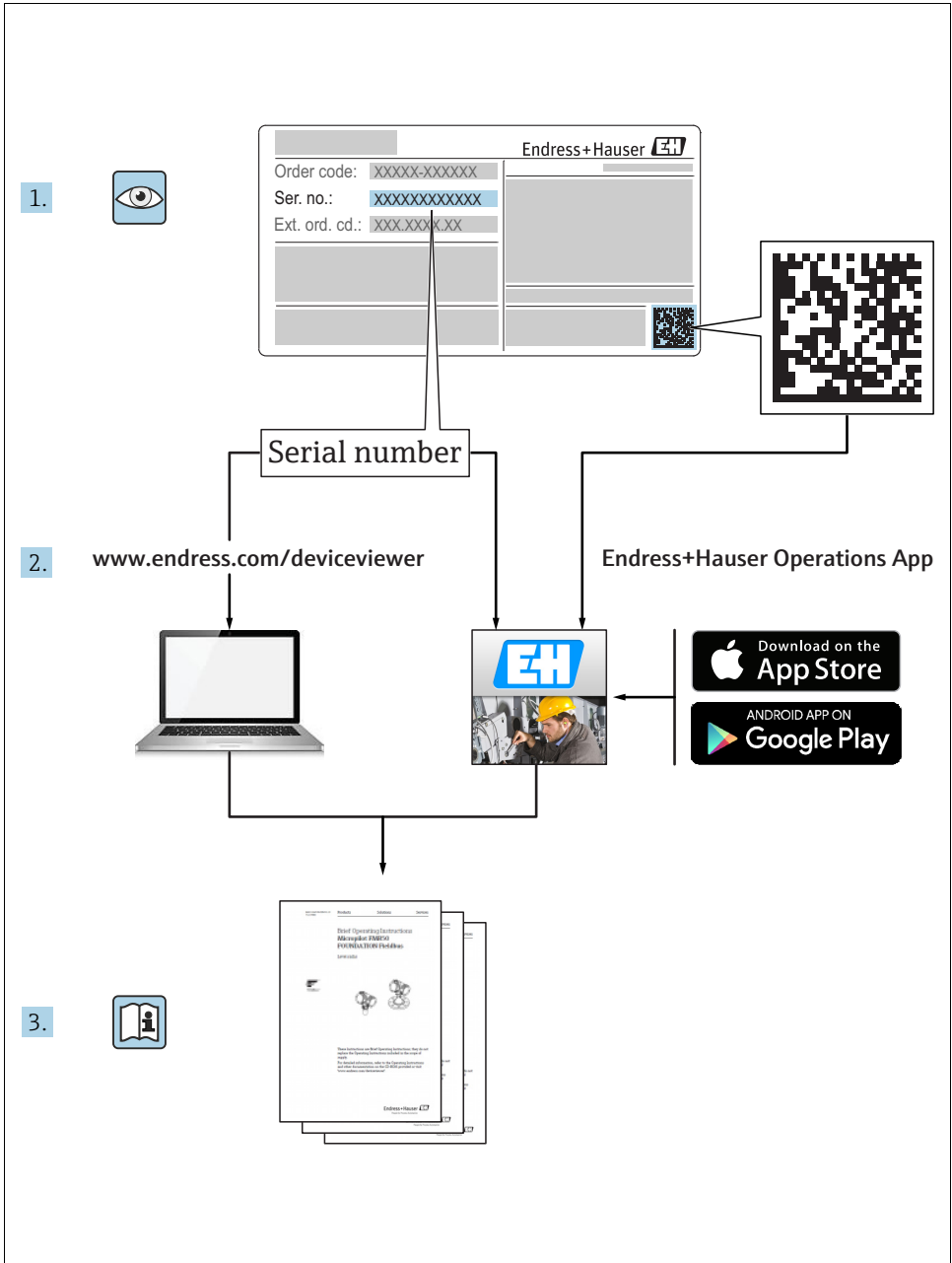

Table of contents

1	Safety Instructions	4
1.1	Designated use	4
1.2	Installation, commissioning, operation	4
1.3	Operational safety and process safety	4
1.4	Return	4
1.5	Safety symbols	5
2	Mounting	6
2.1	Incoming acceptance, storage	6
2.2	Installation	6
2.3	Mounting the remote display and operating module	8
2.4	Mounting of the sensors	10
2.5	Installation check	10
3	Wiring	11
3.1	Terminal compartment of the field housing	11
3.2	Terminal compartment of the DIN-rail housing	12
3.3	Terminal assignment	14
3.4	Sensor connection	16
3.5	Synchronization line	17
3.6	Connection of the separate display and operating module	18
3.7	Potential equalization	18
3.8	Post-connection check	21
4	Operation	22
4.1	Operating options	22
4.2	Operation via the display and operating module	22
5	Commissioning	27
5.1	Setting the device address	27
5.2	Bus termination	28
5.3	Loading the device database and type files (GSD)	29
5.4	First setup	29
5.5	Basic setup	30

1 Safety Instructions

1.1 Designated use

The Prosonic S FMU95 is a transmitter for up to 10 ultrasonic sensors FDU90, FDU91, FDU91F, FDU92, FDU93 and FDU95¹⁾. The sensors of the class FDU8x can be connected as well.

1.2 Installation, commissioning, operation

The Prosonic S FMU95 is fail-safe and constructed to the state-of-the-art. It meets the appropriate standards and EC directives. However, if you use it improperly or other than for its designated use, it may pose application-specific hazards, e.g. product overflow due to incorrect installation or configuration. Installation, electrical connection, start-up, operation and maintenance of the measuring device must therefore be carried out exclusively by trained specialists authorised by the system operator. Technical personnel must have read and understood these operating instructions and must adhere to them. You may only undertake modifications or repair work to the device when it is expressly permitted by the operating instructions.

1.3 Operational safety and process safety

- Alternative monitoring measures must be taken to ensure operational safety and process safety during configuration, testing and maintenance work on the device.
- The device is safely built and tested according to state-of-the-art technology and has left the factory in perfect condition as regards technical safety. The applicable regulations and European standards have been taken into account.
- Pay particular attention to the technical data on the nameplate.
- If the device is to be installed in an explosion hazardous area, then the specifications in the certificate as well as all national and local regulations must be observed. The device is accompanied by separate "Ex documentation", which is an integral part of this Operating Instructions. The installation regulations, connection values and Safety Instructions listed in this Ex document must be observed. The documentation number of the related Safety Instructions is also indicated.
- If using devices for applications with safety integrity level, the separate manual on functional safety must be observed thoroughly.





 The sensors FDU83, FDU84, FDU85 and FDU86 with an ATEX, FM or CSA certificate are not certified for connection to the FMU95 transmitter.



1.4 Return

Follow the instructions on returning the device as outlined in the Operating Instructions BA00344F or on www.endress.com.

1) The sensors FDU80/80F/81/81F/82/83/84/85/86/96 are not available anymore.

1.5 Safety symbols

Symbol	Meaning
 A0011189-DE	DANGER! This symbol alerts you to a dangerous situation. Failure to avoid this situation will result in serious or fatal injury.
 A0011190-DE	WARNING! This symbol alerts you to a dangerous situation. Failure to avoid this situation can result in serious or fatal injury.
 A0011191-DE	CAUTION! This symbol alerts you to a dangerous situation. Failure to avoid this situation can result in minor or medium injury.
 A0011192-DE	NOTICE! This symbol contains information on procedures and other facts which do not result in personal injury.

Explosion protection	Meaning
	Device certified for use in explosion hazardous area If the device has this symbol embossed on its name plate it can be installed in an explosion hazardous area
	Explosion hazardous area Symbol used in drawings to indicate explosion hazardous areas. Devices located in and wiring entering areas with the designation "explosion hazardous areas" must conform with the stated type of protection.
	Safe area (non-explosion hazardous area) Symbol used in drawings to indicate, if necessary, non-explosion hazardous areas. Devices located in safe areas still require a certificate if their outputs run into explosion hazardous areas

2 Mounting

2.1 Incoming acceptance, storage

2.1.1 Incoming acceptance

Check the packing and contents for any signs of damage. Check the shipment, make sure nothing is missing and that the scope of supply matches your order.

2.1.2 Storage

Pack the measuring instrument so that is protected against impacts for storage and transport. The original packing material provides the optimum protection for this. The permissible storage temperature is -40 to +60 °C (-40 to +140 °F).

2.2 Installation

2.2.1 Installation conditions of the field housing

Weather protection

In order to avoid excessive sunlight exposure, the instrument should be mounted in a position which is protected against direct sunlight or a protection cover should be applied.

Overvoltage protection

In order to protect the Prosonic S against overvoltages (especially if mounted outdoors), connection of an overvoltage protection is recommended.

Pipe mounting

A mounting plate is available for mounting of the field housing to 1" to 2" pipes.

Wall mounting

A mounting help for wall mounting is supplied. It also serves as drilling template. The mounting help should be mounted on a flat surface and may not become distorted.

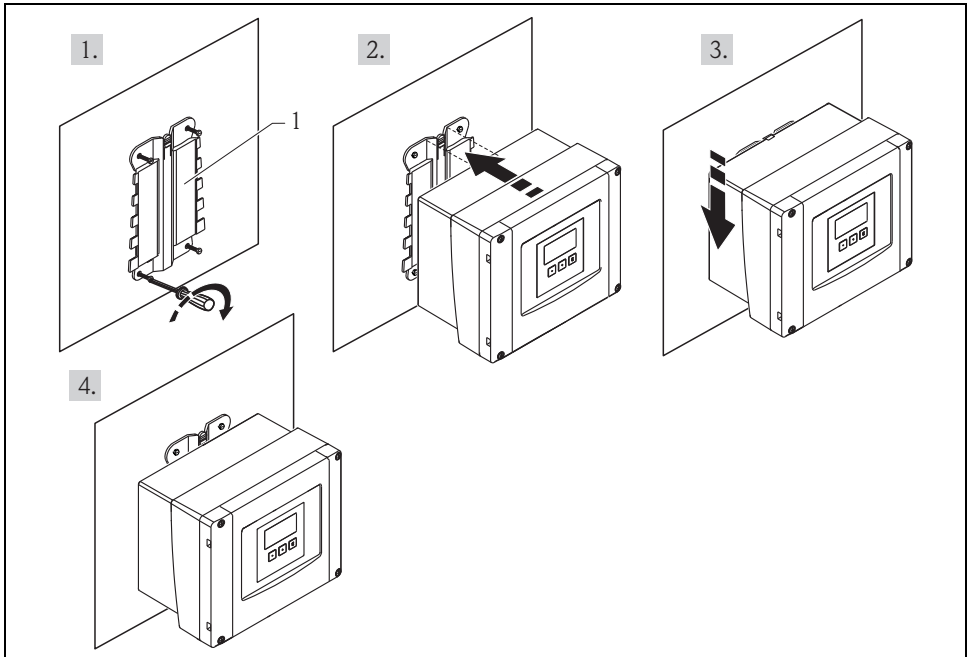

L00-FMU90xxx-17-00-00-xx-003

Wall mounting with mounting help (1)



Further information: Operating Instructions for Prosonic S FMU95, document number BA00344F.

You will find this document in the Download Area of the Endress+Hauser Internet site.

2.2.2 Installation conditions of the DIN-rail housing

- The DIN-rail housing must be mounted outside hazardous areas in a cabinet.
- The housing is mounted on a DIN rail EN 60715 TH 35 x 7.5 or TH 37 x 15.
- Do not install the instrument in the vicinity of high-voltage lines, motor lines, contactors or frequency converters. The installation regulations for high-voltage lines, motor lines, contactors or frequency converters must be observed.
- To ensure easy mounting and opening of the housing, a distance of approx. 10 mm (0.39 in) should be kept between the instruments.
- In order to avoid interference, do not route the sensor cables parallel to high-voltage or electric power lines and not close to frequency converters.

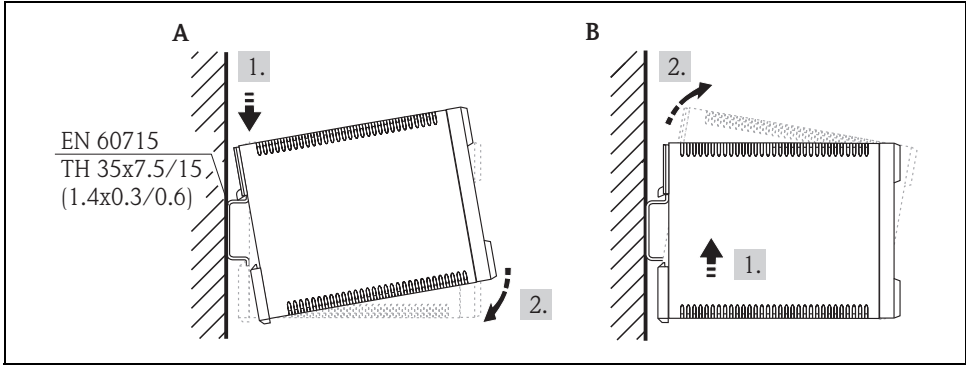

L00-FMU90xxx-17-00-00-xx-001

A Mounting
 B Demounting

 The dimensions are described in this document: Technical Information for Prosonic S FMU95, document number TI00398F. You will find this document in the Download Area of the Endress+Hauser Internet site.

2.3 Mounting the remote display and operating module

2.3.1 Scope of delivery

If the Prosonic S is ordered with the display for cabinet door mounting, the following is contained in the scope of delivery:

- Display and operating module 96 x 96 mm (3.78 x 3.78 in)
- 4 retainers (with nuts and screws) →  9> "Mounting"
- Connection cable (3 m (9.8 ft)) for connection to the transmitter (preassembled with suitable plugs).

2.3.2 Dimensions

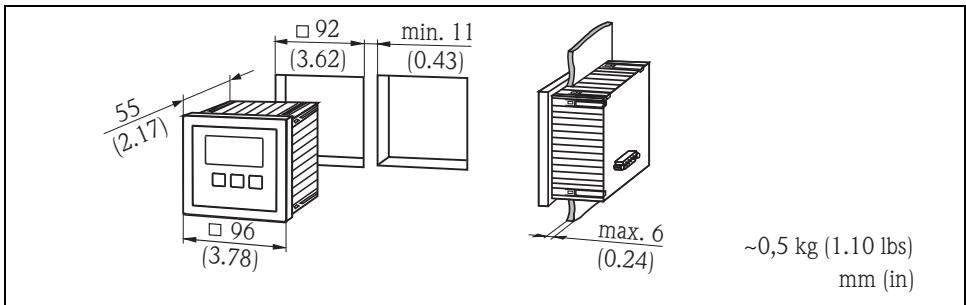

L00-FMU90xxx-06-00-00-xx-004

2.3.3 Mounting

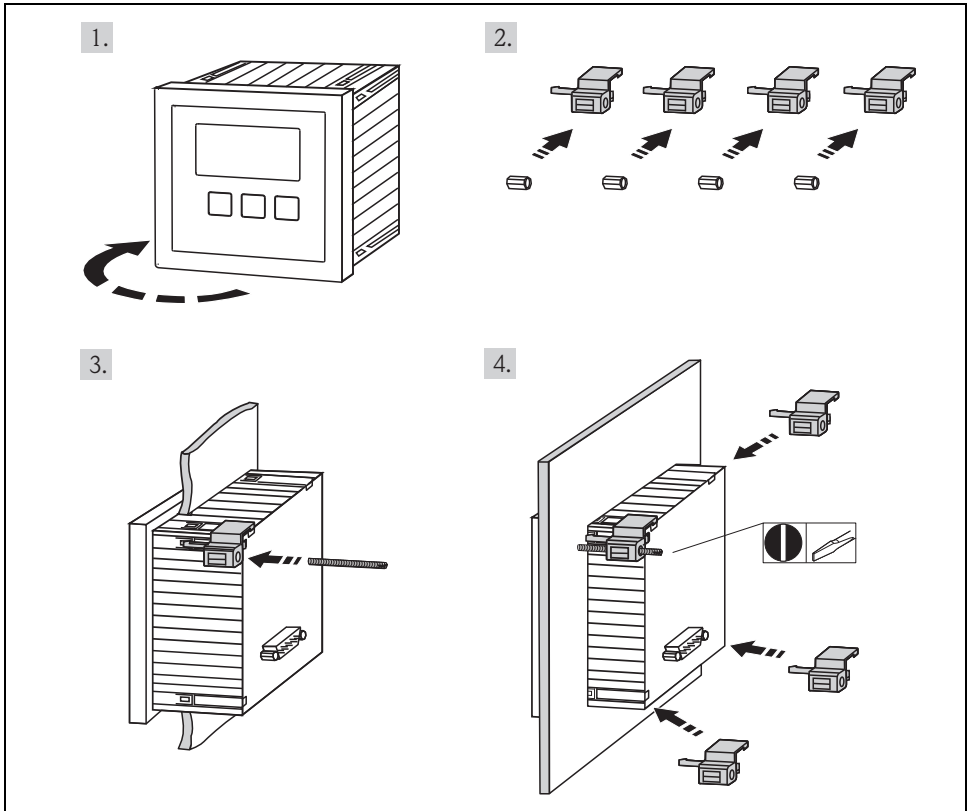

L00-FMU90xxx-17-00-00-xx-002



Further information: Operating Instructions for Prosonic S FMU90, document number BA00344F.

You will find this document in the Download Area of the Endress+Hauser Internet site.

2.3.4 Adaption plate

If an opening of 138 x 138 mm (5.43 x 5.43 in) and the remote display of the Prosonic FMU860/861/862 are already present, you can use the adaption plate (Order Code: 52027441). The adapter plate can be mounted directly in the housing of the old remote display of the FMU86x series.



The housing of the remote display of the FMU86x is the holder for the adapter plate and the new remote display of the FMU90/FMU95 in the format 96 x 96 mm (3.78 x 3.78 in).

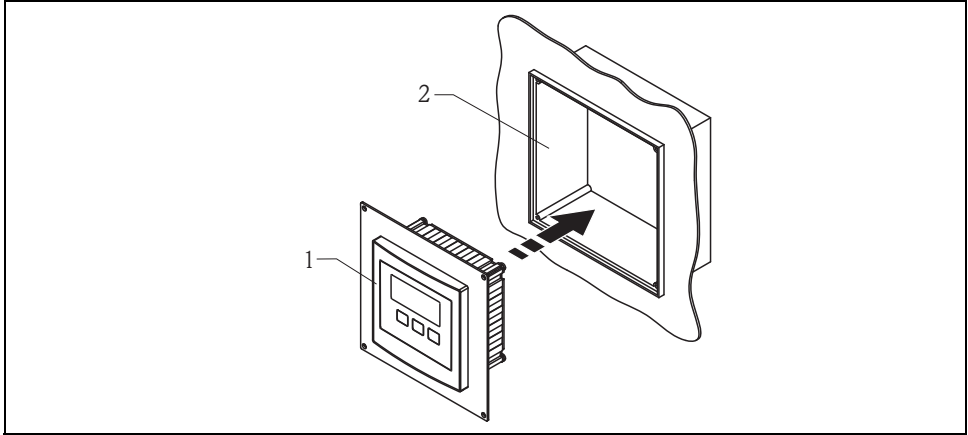

L00-FMU90xxx-06-00-00-xx-006

- 1 Remote display of the FMU90 with adaption plate
- 2 Opening of the remote display of the FMU860/861/862

2.4 Mounting of the sensors

Information on the mounting of the sensors²⁾ can be found in the following documents:

- Technical Information TI00189F (for FDU8x)
- Technical Information TI00396F (for FDU9x)

These documents are supplied with the sensors.

2.5 Installation check

After installing the device, carry out the following checks:

- Is the device damaged (visual inspection)?
- Does the device correspond to the measuring point specifications such as process temperature, process pressure, ambient temperature, measuring range, etc.?
- If available: Are the measuring point number and labelling correct?
- Is the instrument sufficiently protected against rainfall and direct sunlight?
- For the field housing: Are the cable glands tightened correctly?
- Is the instrument securely mounted to the DIN rail or the mounting help (visual inspection)?
- For the field housing: Are the screws of the terminal compartment cover securely tightened (visual inspection)?

2) The sensors FDU80/80F/81/81F/82/83/84/85/86/96 are not available anymore.

3 Wiring

▲ WARNING

Risk of electric shock!

Voltage at the terminals.

- ▶ Switch off the supply voltage before connecting the device.
- ▶ In a wet environment, do not open the cover if voltage is present.

3.1 Terminal compartment of the field housing

The field housing has a separate terminal compartment. It can be opened after loosening the 4 screws of the lid.

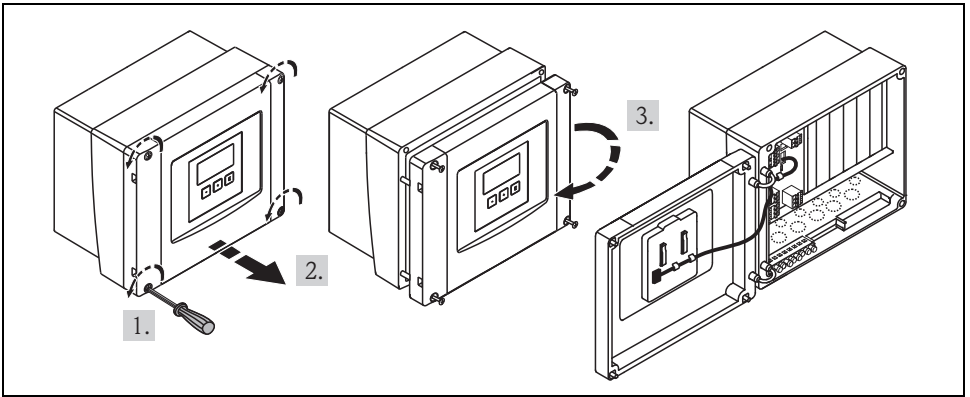

L00-FMU90xxx-04-00-00-xx-002

For easier wiring, the lid can be completely removed by unplugging the display plug and loosening the hinges:

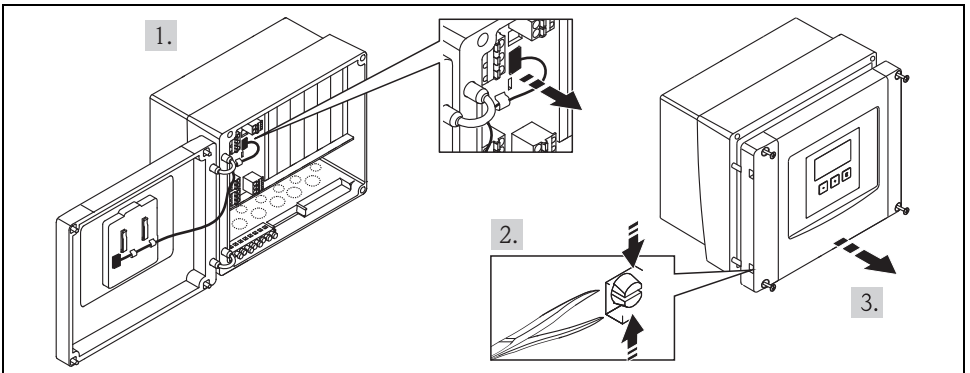

L00-FMU90xxx-04-00-00-xx-009

3.1.1 Cable entries of the field housing

The following openings for cable entries are prestamped on the bottom of the housing:
 M20x1.5 (10 openings), M16x1.5 (5 openings), M25x1.5 (1 opening)

The required number and types of cable entries depend on the application at hand.

3.2 Terminal compartment of the DIN-rail housing

3.2.1 Single instrument

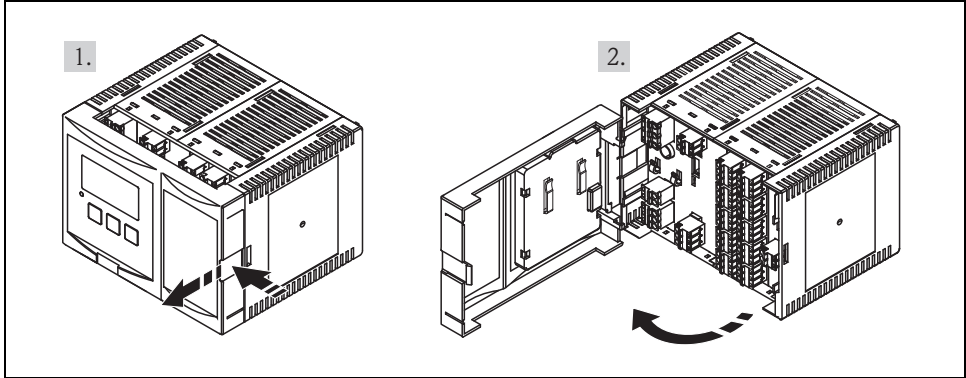

L00-FMU95xxx-04-04-00-00-xx-005

- The cables can be inserted into the housing from above or from below.
- The pictures show the smallest housing version but are valid for the larger versions as well.
- If the instruments are mounted next to each other and if the sensor cables run in parallel, the synchronization terminals (39 and 40) must be interconnected (→ 14>, "Terminal assignment" and → 17>, "Synchronization line").

3.2.2 Several instruments mounted side by side

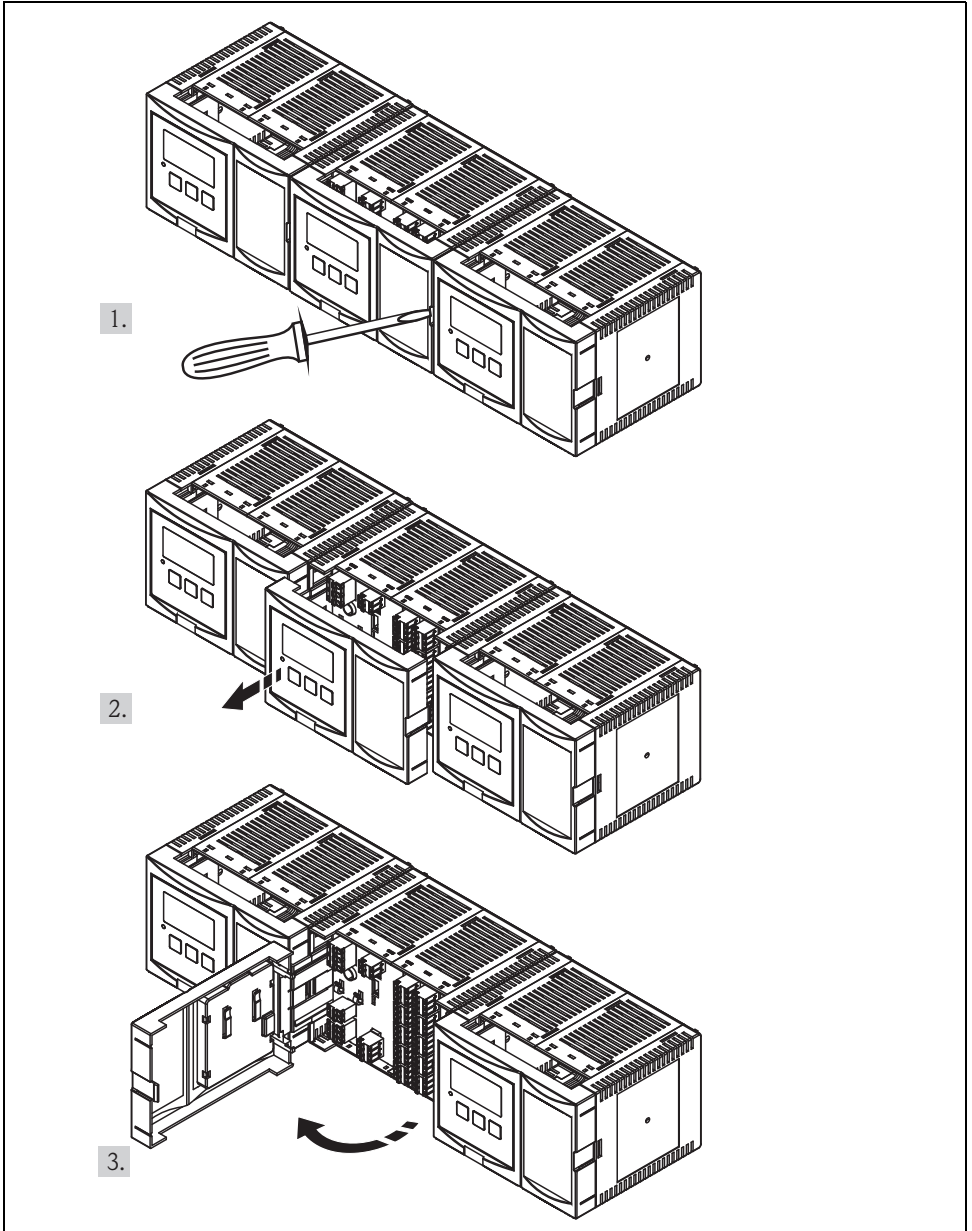

L00-FMU95KAs-04-00-00-xx-005

3.3 Terminal assignment

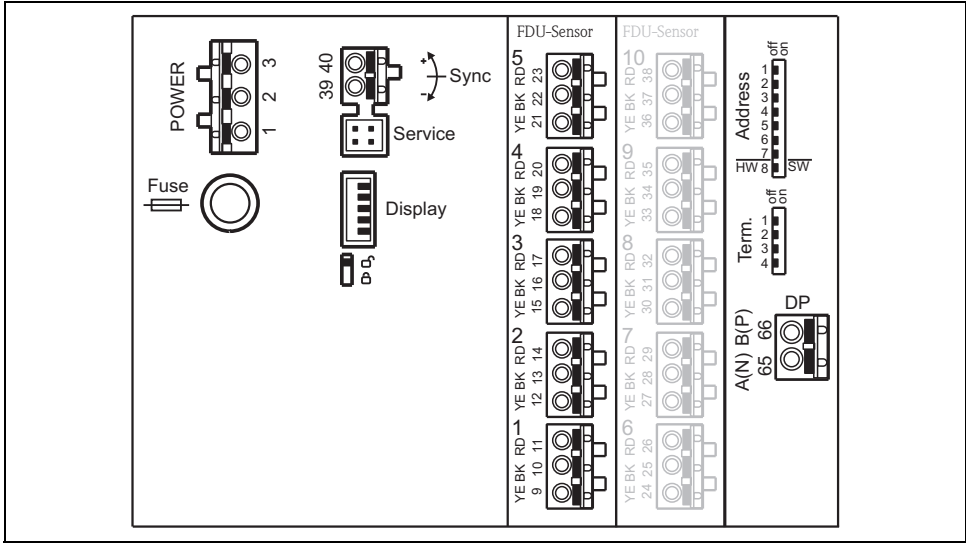

L00-FMU95xxx-04-00-00-xx-003

Terminals of the Prosonic S (the terminals depicted in grey are not present in every instrument version)

Terminals	Meaning	Remarks
Auxiliary energy		
1	<ul style="list-style-type: none"> ▪ L (for AC version) ▪ L+ (for DC version) 	depending on instrument version: <ul style="list-style-type: none"> ▪ 90 to 253 V_{AC} ▪ 10.5 to 32 V_{DC}
2	<ul style="list-style-type: none"> ▪ N (for AC version) ▪ L- (for DC version) 	
3	Potential equalization	
Fuse		depending on instrument version: <ul style="list-style-type: none"> ▪ 400 mA T (for AC) ▪ 2 A T (for DC)
Bus communication		
65	PROFIBUS A (RxT/TxD - N)	
66	PROFIBUS B (RxT/TxD - P)	
Synchronization		
39, 40	Synchronization	→ 17>, "Synchronization line"



Terminals	Meaning	Remarks
Level inputs		
09,10,11	Sensor 1 (FDU8x/9x)	YE: yellow strand BK: black strand RD: red strand
12, 13, 14	Sensor 2 (FDU8x/9x)	
15, 16, 17	Sensor 3 (FDU8x/9x)	
18, 19, 20	Sensor 4 (FDU8x/9x)	
21, 22, 23	Sensor 5 (FDU8x/9x)	
24, 25, 26	Sensor 6 (FDU8x/9x)	only available for the version with 10 sensor inputs YE: yellow strand BK: black strand RD: red strand
27, 28, 29	Sensor 7 (FDU8x/9x)	
30, 31, 32	Sensor 8 (FDU8x/9x)	
33, 34, 35	Sensor 9 (FDU8x/9x)	
36, 37, 38	Sensor 10 (FDU8x/9x)	

CAUTION

Limitation of electrical safety.

- ▶ When using the public supply mains, an easily accessible power switch must be installed in the proximity of the device. The power switch must be marked as a disconnecter for the device (IEC/EN 61010).
-  In order to avoid interference, do not route the sensor cables parallel to high-voltage or electric power lines and not close to frequency converters.

Additional elements on the terminal areas

Designation	Meaning/Remarks
Fuse	Fuse: 2 A T /DC or 400 mA T/AC
Display	Connection of the display or the remote display and operating module (→  18>)
Service	Service interface for connection of a PC/Notebook via Commubox FXA291
	Locking switch
Term.	Bus termination
Address	Bus address

WARNING

Risk of electric shock!

Voltage at the terminals.

- ▶ Switch off the supply voltage before connecting the device.
- ▶ In a wet environment, do not open the cover if voltage is present.



- Basic information on the cyclic data exchange between the measuring instrument and an automation system (e.g. PLC) are described in this document: Operating Instructions "PROFIBUS DP/PA - Guidelines for planning and commissioning", document number BA00034S.
- Further information: Operating Instructions for Prosonic S FMU90, document number BA00344F.

3.4 Sensor connection

Information on the mounting of the sensors³⁾ can be found in the following documents:

- Technical Information TI00189F (for FDU8x)
- Technical Information TI00396F (for FDU9x)

These documents are supplied with the sensors.

3) The sensors FDU80/80F/81/81F/82/83/84/85/86/96 are not available anymore.

3.5 Synchronization line

- If wiring several Prosonic S (FMU90/FMU95) which are mounted in a common cabinet and if the sensor cables run in parallel, the synchronization terminals (39 and 40) must be interconnected.
- Up to 20 instruments can be synchronized in this way.
- The synchronization causes the evaluation units FMU9x to send the pulses simultaneously. Only after all sensors have received their signal, new simultaneous pulses are sent. This prevents pulses in the sensor cable of one sensor from influencing the received signal on the cable of a different sensor.
- If there are more than 20 instruments, groups must be formed, each containing a maximum of 20 instruments. For the instruments within each group, the sensor cables may run in parallel. The sensor cables of different groups must be separated from each other.
- Usual commercial screened cable can be used for synchronization
 - max. length: 10 m (33 ft) between the individual instruments
 - cross section: 2 x (0.75 to 2.5 mm² (18 to 14 AWG))
 - for lengths up to 1 m (3.3 ft), an unscreened cable can be used; for lengths exceeding 1 m (3.3 ft), screening is required. The screen must be connected to ground
- Instruments of the Prosonic FMU86x family can be connected to the synchronization line as well. In this case a maximum of 10 instruments can be connected to each synchronisation line.

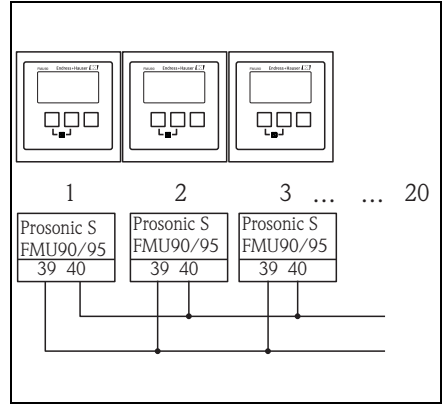

L00-FMU90xxx-04-00-00-xx-004

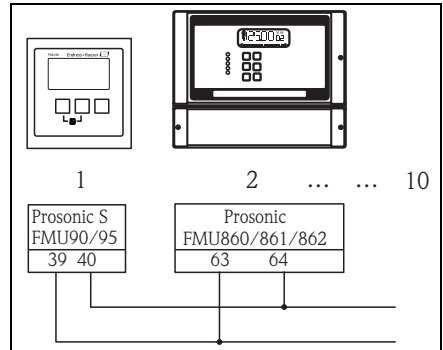

L00-FMU90xxx-04-00-00-xx-017

3.6 Connection of the separate display and operating module

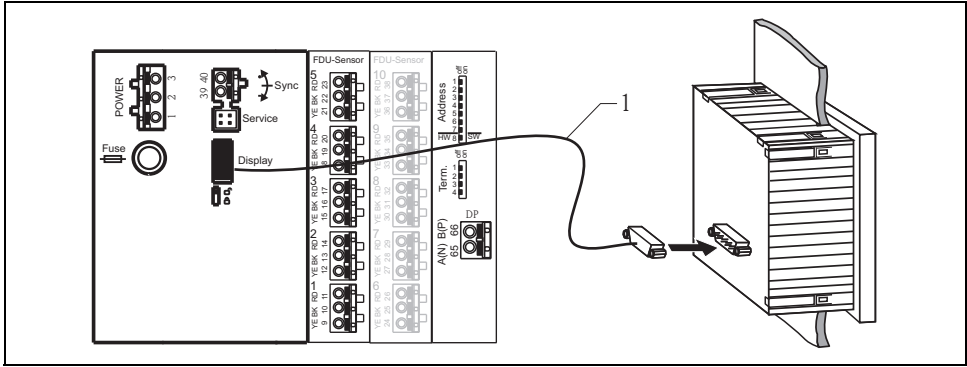

1 Connection of the display plug with the cable (3 m (9.8 ft))

L00-FMU95xxx-04-00-00-xx-008

For the version of the Prosonic S with a separate display for panel mounting, a pre-assembled connecting cable (3 m (9.8 ft)) is supplied. The cable must be connected to the display plug of the Prosonic S.



Minimum diameter for cable bushing: 20 mm (0.79 in).

3.7 Potential equalization

3.7.1 Potential equalization in the field housing

⚠ WARNING

Limitation of electrical safety.

- ▶ The protective conductor (GNYE) of the sensors FDU91F/93/95/96 and FDU83/84/85/86 must be connected to the local potential equalization system **after a maximum of 30 m (98 ft)**. The metallic terminal block (1) in the field housing can be used for this.

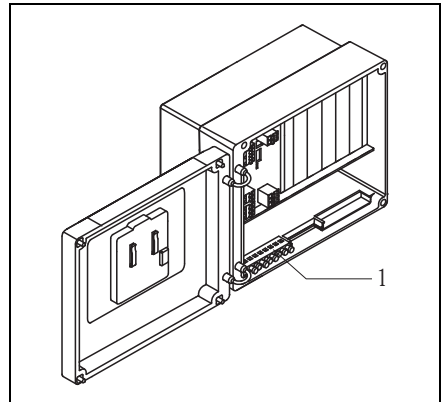

L00-FMU90xxx-04-00-00-xx-006

Example

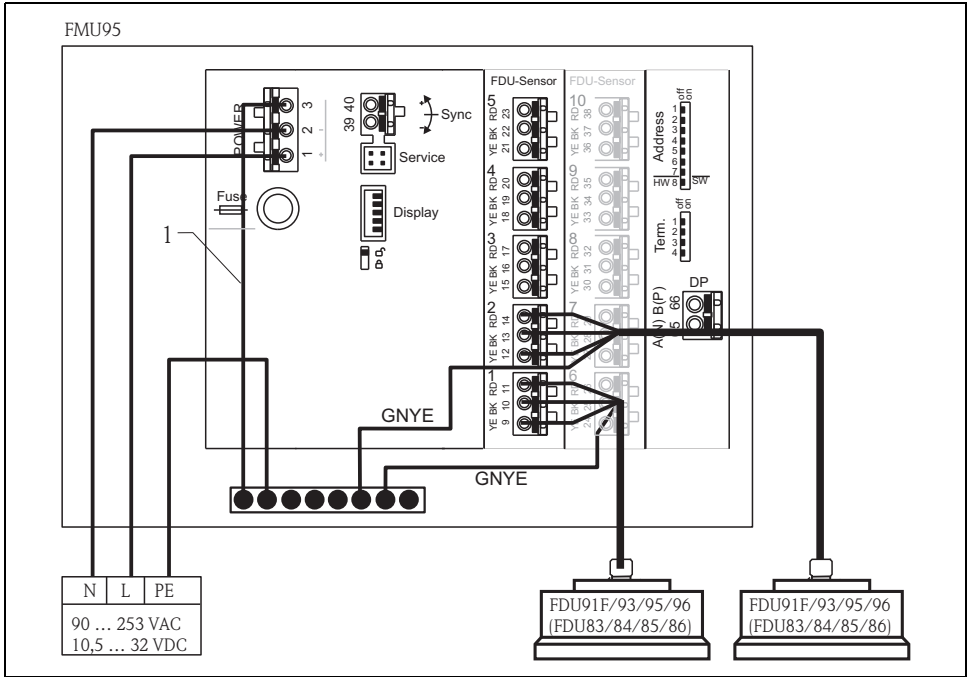

1 The wire is already connected on delivery

L00-FMU95xxx-04-00-00-xx-009

3.7.2 Potential equalization for the DIN-rail housing

If the DIN-rail housing is used, the potential equalization must be connected in the cabinet, e.g. at a metallic DIN rail:

⚠ WARNING

Limitation of electrical safety.

- ▶ The protective conductor (GNYE) of the sensors FDU91F/93/95/96 and FDU83/84/85/86 must be connected to the local potential equalization system **after a maximum of 30 m (98 ft)**.

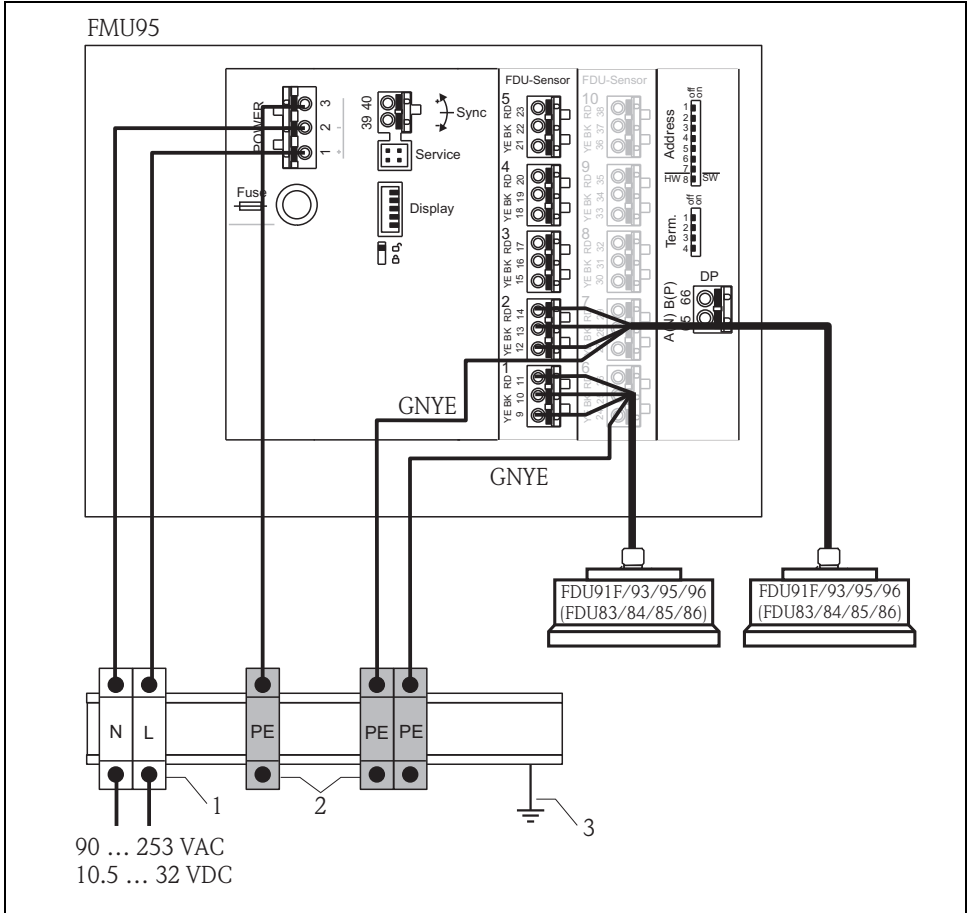

- 1 Terminal (isolated from the DIN rail)
- 2 Protective earth terminal (with contact to the DIN rail)
- 3 Protective ground via DIN rail

L00-FMU95xxx-04-00-00-xx-010

The signal evaluation electronics and its direct connections (display interface, service interface etc.) are galvanically isolated from the supply voltage and the communication signals. Their electric potential is identical to the potential of the sensor electronics.

⚠ CAUTION

Limitation of electrical safety.

- ▶ Pay attention to the potential difference if the sensors are connected to ground!
- ▶ Route the protective conductor (GNYE) in such a manner that the protective conductor will be the last to get strained when the cable is being pulled.

3.8 Post-connection check

⚠ WARNING

Risk of electric shock!

Voltage at the terminals.

- ▶ Switch off the supply voltage before you check the terminal assignment.
- ▶ In a wet environment, do not open the cover if voltage is present.

After wiring the transmitter, carry out the following checks:

- Is the terminal assignment correct?
- For the field housing: Are the cable glands tight and is the cover of the terminal compartment securely closed?
- If auxiliary energy is switched on: Does a display appear on the display module (if available) and does the green LED light up?

4 Operation

4.1 Operating options

- On-site operation
via the display and operating module at the Prosonic S
- Remote operation
 - Via the service interface with the Commubox FXA29 1 and the operating program FieldCare
 - Via PROFIBUS DP with the PROFIcond, PROFIcond or PROFIcond
 - Acyclic data exchange, SLOT index tables

 Further information: Operating Instructions for Prosonic S FMU90, document number BA00344F.

4.2 Operation via the display and operating module



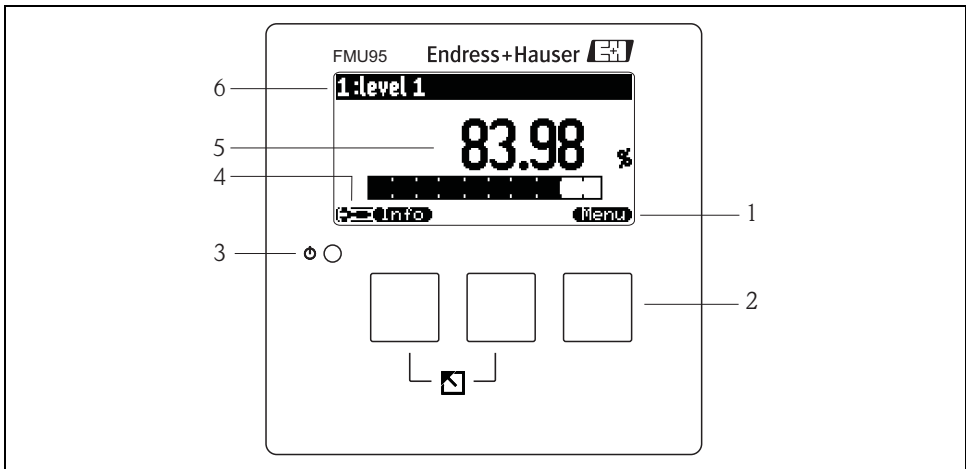







4.2.1 Display and operating elements



L00-FMU95xxx-07-00-00-xx-001









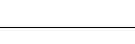

- 1 Softkey symbol
- 2 Key
- 3 LED indicating the operating state
- 4 Display symbols
- 5 Value of the parameter, including unit
- 6 Name of the parameter

Display symbols

Symbol	Meaning
Operating mode of the instrument	
	User User parameters can be edited. Service parameters are locked.
	Diagnosis The service interface is connected.
	Service User and service parameters can be edited.
	Locked All parameters are locked.
Locking state of the currently displayed parameter	
	Display parameter The parameter can not be edited in the current operating mode of the instrument.
	Editable parameter The parameter can be edited.
Scroll-Symbole	
	Scroll list available Indicates that the list contains more parameters than can be represented on the display. By pressing \uparrow or \downarrow repeatedly, all parameters of the list can be accessed.
Navigation in the envelope curve display (select plot setting "cyclic")	
	Move left
	Move right
	Zoom in
	Zoom out



Keys (softkey operation)

The function of the keys depends on the current position within the operating menu (softkey functionality). The key functions are indicated by softkey symbols in the bottom line of the display.

Symbol	Meaning
	Move downwards Moves the marking bar downwards within a selection list.
	Move upwards Moves the marking bar upwards within a selection list.
	Enter <ul style="list-style-type: none"> ▪ Opens the marked submenu, the marked parameter set or the marked parameter ▪ Confirms the edited parameter value
	Previous parameter set Reopens the previous parameter set within the submenu.
	Next parameter set Opens the next parameter set within the submenu.
	Confirm selection Selects the option of a selection list which is currently marked by the bar.
	Increase value Increases the active digit of an alphanumeric parameter.
	Decrease value Decreases the active digit of an alphanumeric parameter
	Error list Opens the list of all errors which are currently detected. If a warning is present, this symbol flashes. If an alarm is present, the symbol is displayed continuously.
	Change Display Change to the next page of measured values (only available if more than one pages of measured values have been defined; see "display" menu)
	Info Opens the Shortcut Menu, which contains the most important information about the current state of the instrument
	Menu Opens the Main Menu, which contains all parameters of the Prosonic S

General key combinations

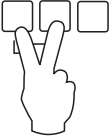
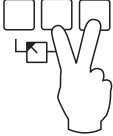
The following key combinations do not depend on the menu position:

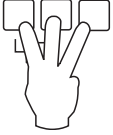
Key combination	Meaning
	<p>Escape</p> <ul style="list-style-type: none"> ■ While editing a parameter: Exit the editing mode without accepting the changes. ■ Within the navigation: Move upwards to the previous layer of the menu.
	<p>Increase contrast Increases the contrast of the display module.</p>
	<p>Decrease contrast Decreases the contrast of the display module.</p>
	<p>Locking Locks the instrument against parameter changes. The instrument can only be unlocked again by the keys.</p>

4.2.2 The operating menu

Structure of the menu

The parameters of the Prosonic S are organized in an operating menu (consisting of a main menu and several submenus). Parameters which are related to each other are comprised in a common parameter set. To simplify the navigation within the menu, a five-digit position code is displayed with each parameter set.

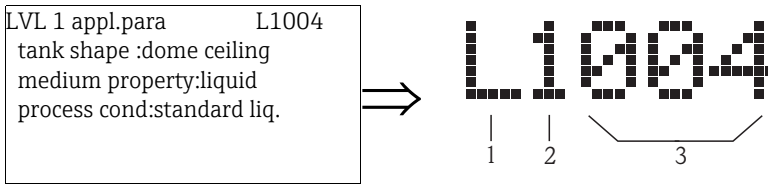

Identification of the parameter sets:

- 1 Submenu
- 2 Number of the associated input or output
- 3 Number of the parameter set within the submenus

 Further information: Operating Instructions for Prosonic S FMU95, document number BA00344F.

5 Commissioning

5.1 Setting the device address

5.1.1 Selecting the device address

- Every PROFIBUS device must be given an address. If the address is not set correctly, the device will not be recognised by the process control system.
- A device address may appear only once within a particular PROFIBUS network.
- Valid device addresses are in the range between 1 and 126. All devices are delivered from the factory with the address 126, which is set by software.
- The default address can be used to check the function of the device and connect it to an operating PROFIBUS system. Afterwards the address must be changed to allow other devices to be connected to the network.

5.1.2 Software addressing

Software addressing comes into operation, when DIP-switch 8 on the PROFIBUS DP terminal area is in the position "ON".

In this case, the address can be set by an operating tool ("FieldCare").

The address is displayed in the function "Output-calculations/PROFIBUS DP/instrument address".

5.1.3 Hardware addressing

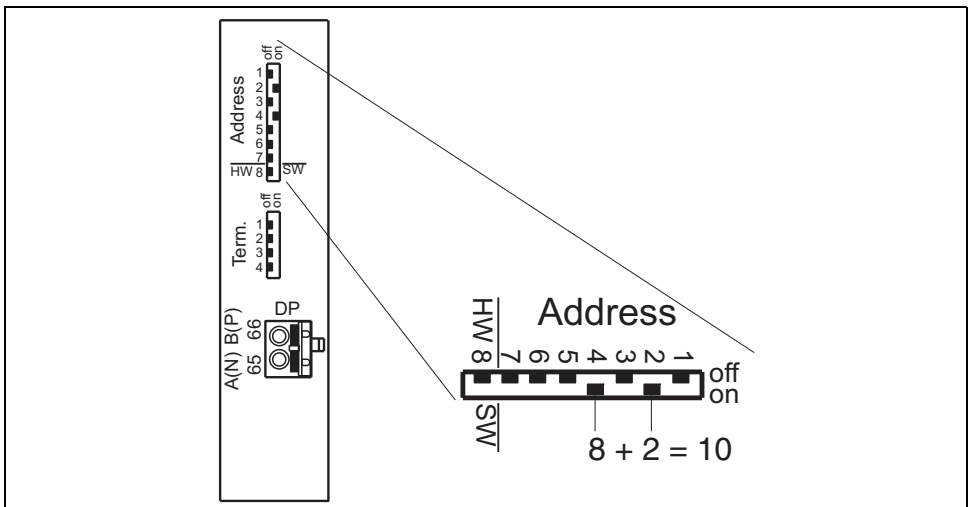

L00-FMU90xxx-04-00-00-xx-016

Hardware addressing comes into operation when DIP switch 8 is in the position "HW (OFF)". In this case the address is determined by the position of DIP-switches 1 to 7 according to the following table:

Switch No.	1	2	3	4	5	6	7
Value in position "OFF"	0	0	0	0	0	0	0
Value in Position "ON"	1	2	4	8	16	32	64

The new address becomes valid 10 seconds after switching.

5.2 Bus termination

The termination resistor must be activated for the last instrument on the bus. This is done by setting all 4 termination switches into the "on" position.

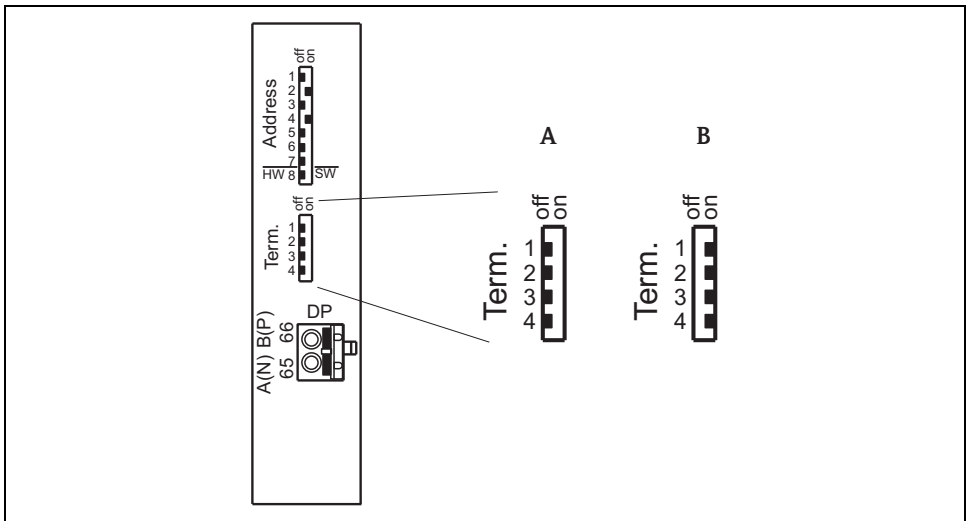

- A Termination off (factory setting)
- B Termination on

L00-FMU90xxx-04-00-00-xx-01B

5.3 Loading the device database and type files (GSD)

5.3.1 Meaning of the GSD files

A device database file (GSD) contains a description of the properties of the PROFIBUS device, e.g. the supported transmission rates and the type and format of the digital information output to the PLC. Additional bitmap files are required in order to represent the device by an icon in the network design software. The device database and bitmap files are needed for the commissioning of a PROFIBUS DP network.



Further information: Operating Instructions for Prosonic S FMU95, document number BA00344F.

5.4 First setup

After switching on the power supply for the first time, the instrument asks for a number of operating parameters:

- Select by ↓ or ↑
- Confirm by ↵

Step	Parameter	Remarks
1	→ language	Select the display language.
2	→ distance unit	Select the unit for distance measurements.
3	→ temperature unit	Select the temperature unit.



By pressing  you can return to the previous parameter (e.g. in order to correct the value). All these parameters can also be changed at a later point of time in the "device properties/operating parameters" and "device properties/language" parameter sets.

5.5 Basic setup

After the first setup the main screen appears.

However, the displayed value does not correspond to the real level before you have performed the basic setup. To do so, enter the main menu by pressing "Menu" (right key).

Step	Parameter set	Parameter	Remarks
1	Main menu → level	→ Level (LVL)1	Select the "level" submenu. In the following submenu select the level channel you are going to calibrate.
2	Main menu → level → level (LVL)1	→ Basic setup	In the following submenu select "basic setup". This submenu contains all parameters needed for the basic setup.

5.5.1 Overview basic setup

The following table gives an overview of the basic setup for level measurement. Detailed information on the parameters can be found in the Operating Instructions BA00344F.



Step	Parameter set	Parameter	Remarks
Configuring the sensor (Details Section 5.5.2)			
1	→ LVL N sensor selection (N = 1 - 5 or 10)	→ Input	Allocate a sensor to the channel.
		→ Sensor selection	Specify the type of sensor ("automatic" for FDU9x)
		→ Detected	only available for "sensor selection" = "automatic"; indicates the detected type of sensor
2	→ LVL N application parameter (N = 1 - 5 or 10)	→ Tank shape	Select the appropriate values for your application.
		→ Medium property	
		→ Process conditions	
Empty and full calibration (Details Section 5.5.3)			
3	→ LVL N empty calibration (N = 1 - 5 or 10)	→ Empty E	Specify the distance between the reference point of the sensor and the minimum level (0%).
4	→ LVL N full calibration (N = 1 - 5 or 10)	→ Full F	Specify the distance between the minimum (0%) and maximum (100%) level.
		→ Blocking distance (BD)	Display parameter; the maximum value for the full calibration is: $F_{\max} = E - BD$
5	→ LVL N unit (N = 1 - 5 or 10)	→ Unit level	Select the unit for the level measurement.
		→ Level N (N = 1 - 5 or 10)	Displays the currently measured level.
		→ Distance	Displays the currently measured distance between the reference point of the sensor and the product level.

Step	Parameter set	Parameter	Remarks
Linearization (Details Section 5.5.4) If no linearization is required: continue by step 7: "distance correction"			
6	→ LVL N linearization (N = 1 - 5 or 10)	→ Type	Select type of linearization (Details → 37 "type")
		→ Mode	Specify, to which value the measurement refers: "level" or "ullage"
		→ Customer unit	Specify the unit for the linearized value; (not available for "type" = "none") (Details → 39 "customer unit")
		→ Max. scale	Specify the maximum contents of the vessel (in customer units); (not available for "type" = "none")
		→ Diameter	Specify the diameter of the tank; (only available for "type" = "horizontal cylinder" or "sphere")
		→ Intermediate height	Specify the intermediate height of the tank or silo; (only available for "type" = "pyramid bottom", "conical bottom" oder "angled bottom")
		→ Edit	Used to enter, change or delete a linearization table; (only available for "type" = "table") Details → 39 "edit"
		→ Status table	Enables or disables the linearization table; (only available for "type" = "table") Details → 40 "status table"
Interference echo suppression (Details Section 5.5.5)			
7	→ LVL N check value (N = 1 - 5 or 10)	→ Act. distance N	Indicates the currently measured distance between the reference point of the sensor and the product surface.
		→ Check distance	Compare the indicated distance with the real value: <ul style="list-style-type: none"> ▪ "Distance = ok" → "distance mapping" ▪ "Distance too small" → "distance mapping" ▪ "Distance too big" → Basic setup completed ▪ "Distance unknown" → Basic setup completed ▪ "Manual" → "distance mapping"
8	→ LVL N dist. map. (N = 1 - 5 or 10)	→ Act. distance N	Indicates the currently measured distance between the reference point of the sensor and the product surface.
		→ Range of mapping	Determines the range over which the mapping is recorded; confirm the predefined value or enter your own value.
		→ Start mapping	Select: <ul style="list-style-type: none"> ▪ No: the mapping is not recorded ▪ Yes: the mapping is recorded; after completion the "LVL N state" function appears (see below)

Step	Parameter set	Parameter	Remarks
9	→ LVL N state (N = 1 - 5 or 10)	→ Level N	Indicates the currently measured level.
		→ Act. distance	Indicates the currently measured distance between the reference point of the sensor and the product surface. Check the value: <ul style="list-style-type: none"> ▪ Value correct: → Basic setup completed. Return to the measured value display by pressing \leftarrow several times ▪ Value not correct: → go back to step 7 ("distance correction")
		→ Status	Used to enable, disable or delete a mapping

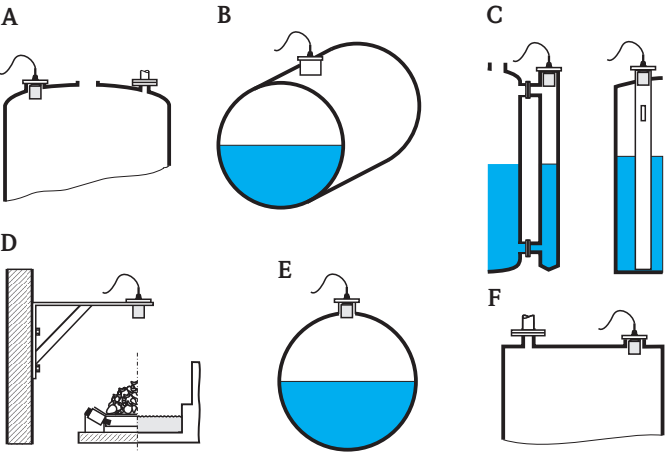
5.5.2 Application parameters

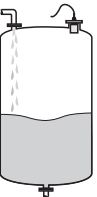
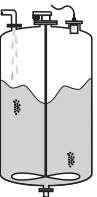
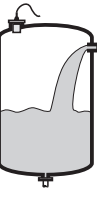
Parameter	Selection/Remarks
<p>"tank shape"</p>	<p>Use this parameter to specify the tank shape of your application:</p> <p>Selection:</p> <ul style="list-style-type: none"> ■ dome ceiling (→ A) ■ horizontal cyl. (→ B) ■ bypass (→ C) ■ stilling well (ultrasonic guide pipe) (→ D) ■ no ceiling (→ E) ■ sphere (→ E) ■ flat ceiling (→ F)  <p style="text-align: right;"><small>L00-FMU30KAx-14-00-06-xx-001</small></p>
<p>"medium property"</p>	<p>Use this parameter to specify the type of medium.</p> <p>You have the following options:</p> <ul style="list-style-type: none"> ■ Unknown (e.g. pasty media such as greases, creams, gels etc.) ■ Liquid ■ Solid, grain size < 4 mm (fine) ■ Solid, grain size > 4 mm (coarse) <p>If the medium does not fit into one of the groups, select "Unknown".</p>
<p>"process conditions"</p>	<p>Use this parameter to specify the process conditions of your application. The filters of the signal evaluation are automatically adjusted to the selected conditions.</p> <p>For this function, you have the following options → see the table:</p>

"process conditions"	for the following situations	Example	filter settings
standard liquid	for all fluid applications which do not fit in any of the following groups		The filters and output damping are set to average values.
calm surface	Storage tanks with immersion tube or bottom filling		The averaging filters and output damping are set to large values. -> stable measured value -> accurate measurement -> slow reaction time
turbulent surface	Storage/accumulation tanks with uneven surface due to free filling, mixing nozzles or small bottom stirrers		Special filters for stabilizing the input signal are activated. -> stable measured value -> medium reaction time
additional agitator	Moving surfaces (possibly with vortex formation) due to agitators		Special filters for stabilizing the input signal are set to large values. -> stable measured value -> medium reaction time
fast change	Rapid level change, particularly in small tanks		The averaging filters are set to small values. -> rapid reaction time -> possibly unstable measured value
standard solid	For all bulk solid applications which do not fit in any of the following groups.		The filter and output damping are set to average values.

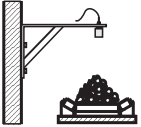
"process conditions"	for the following situations	Example	filter settings
solid dusty	Dusty bulk solids		The averaging filters are set to detect even relatively weak signals.
conveyor belt	Bulk solids with rapid level change		The averaging filters are set to small values. -> rapid reaction time -> possibly unstable measured value
test: no filter	For service and diagnosis only		All filters are switched off.

5.5.3 Empty and full calibration

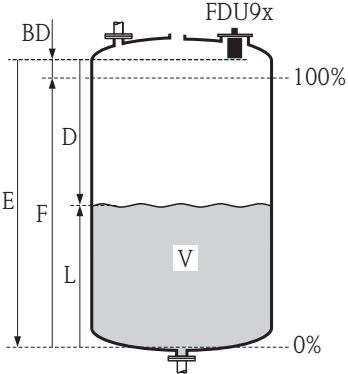
Parameter	Remarks
"empty calibration"	<p>Use this parameter to specify the empty distance E, i.e. the distance between the reference point of the sensor and the minimum level (zero point).</p> <p>Notice! Value of zero will not be displayed, if zero point is set too low. If the zero point is set below the tank bottom, a level value greater than zero is displayed even when the tank is empty. The zero point should not be deeper than the point at which the ultrasonic wave impinges on the tank bottom.</p>  <p><i>BD</i> Blocking distance <i>D</i> Distance from reference point of the sensor to fluid surface <i>E</i> Empty distance <i>F</i> Span (full distance) <i>L</i> Level <i>V</i> Volume (or mass)</p>
"full calibration"	Use this parameter to specify the span F, i.e. the distance from the minimum level to the maximum level. The maximum level may not project into the blocking distance
"blocking distance"	<p>Indicates the blocking distance of the respective sensor. The blocking distance is measured from the reference point of the respective sensor.</p> <p>Further information: Technical Information for Prosonic S FDU9x, document number TI00396F.</p>

5.5.4 Linearization

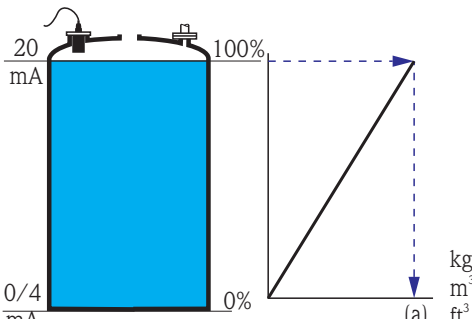
Parameter	Selection/Remarks
"type"	<p>Number and type of the parameters in this set depend on the selected linearization type. Only the parameters "type" and "mode" are always present.</p> <p>Selection</p> <ul style="list-style-type: none"> ▪ None <p>In this linearization type the measured level is not converted but displayed in the selected level unit (see "unit level").</p> <hr/> <p>Selection</p> <ul style="list-style-type: none"> ▪ Linear <p>The following additional parameter have to be specified.</p> <ul style="list-style-type: none"> ▪ Unit for the linearized value, e.g. kg, m³, ft³, ... ("customer unit") ▪ Maximum capacity (a) of the vessel, measured in the customer unit ("maximum scale"). 

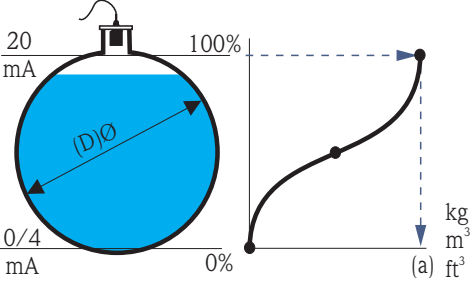
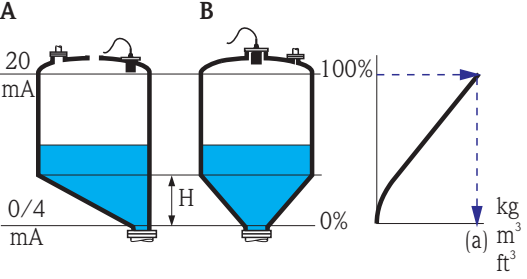
Parameter	Selection/Remarks
"type"	<p>In these linearization types the measured level is converted to the volume in a horizontal cylinder or a spherical tank.</p> <p>Selection</p> <ul style="list-style-type: none"> ■ Horizontal cylinder ¹⁾ ■ Sphere <p>The following additional parameters have to be specified:</p> <ul style="list-style-type: none"> ■ Unit of the linearized value, e.g. kg, m³, ft³, ... ("customer unit") ■ Diameter (D) of the tank ("diameter") ■ Maximum capacity (a) of the tank, measured in the customer unit ("maximum scale") 
	<p>In these linearization modes the measured level is converted to the volume in the respective type of vessel.</p> <p>Selection</p> <ul style="list-style-type: none"> ■ Angled bottom (A) ■ Pyramid bottom (B) ■ Conical bottom (B) <p>The following additional parameters have to be specified:</p> <ul style="list-style-type: none"> ■ Unit for the linearized value, e.g. kg, m³, ft³, ... ("customer unit") ■ Intermediate height H according to the diagram ("intermediate height") ■ Maximum capacity (a) of the tank, measured in the customer unit ("maximum scale"). 

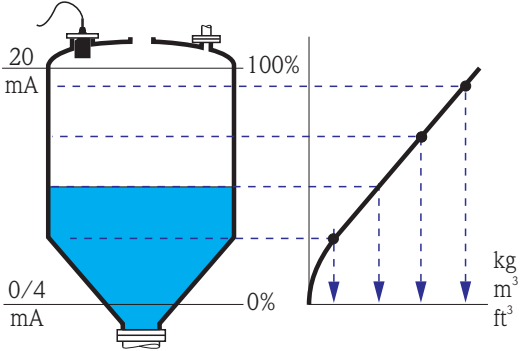
Parameter	Selection/Remarks
"type"	<p>In this linearization mode the measured value is calculated from a linearization table. The table may consist of up to 32 pairs of values (level - volume). The table must be monotonically increasing or decreasing.</p> <p>Selection</p> <ul style="list-style-type: none"> ▪ table <p>The following additional parameters have to be specified:</p> <ul style="list-style-type: none"> ▪ the unit of the linearized value, e.g. kg, m³, ft³, ... ("customer unit") ▪ the linearization table ("edit") 
"customer unit"	<p>Use this parameter to select the desired unit for the linearized values (e.g. kg, m³, ft³, ...). This unit is only indicated on the display. It does not cause a conversion of the measured value.</p> <p>If you want to type in a unit, select the option "customer specific".</p> <p>The parameter "customized text" appears, where you can enter an arbitrary unit (consisting of up to 5 alphanumeric characters).</p>
"edit"	<p>Use this parameter to enter, change or read a linearization table. There are the following options:</p> <p>Selection</p> <ul style="list-style-type: none"> ▪ Read The table editor is opened. The existing table can be read but not changed. ▪ Manual The table editor is opened. Table values can be entered and changed. (→ \square 40>, "status table"). ▪ Semi automatic The table editor is opened. The level is automatically read by the Prosonic S. The measured value (volume, weight or flow) must be entered by the user. ▪ Delete The linearization table is deleted.

Parameter	Selection/Remarks																														
The table editor																															
<table border="1" style="width: 100%; border-collapse: collapse; margin-bottom: 10px;"> <thead> <tr> <th>No.</th> <th>Level</th> <th>Value</th> </tr> </thead> <tbody> <tr style="background-color: #cccccc;"> <td>1</td> <td>0,0000</td> <td>0,0000</td> </tr> <tr> <td>2</td> <td>0,0000</td> <td>0,0000</td> </tr> <tr> <td>3</td> <td>0,0000</td> <td>0,0000</td> </tr> <tr> <td>...</td> <td>0,0000</td> <td>0,0000</td> </tr> </tbody> </table> <p> <input type="checkbox"/> : go to next row <input type="checkbox"/> : go to previous row <input type="checkbox"/> : open marked row for editing </p> <p> <input type="checkbox"/> <input type="checkbox"/> Return to the previous step by this key combination. </p>	No.	Level	Value	1	0,0000	0,0000	2	0,0000	0,0000	3	0,0000	0,0000	...	0,0000	0,0000	<table border="1" style="width: 100%; border-collapse: collapse; margin-bottom: 10px;"> <thead> <tr> <th>No.</th> <th>Level</th> <th>Value</th> </tr> </thead> <tbody> <tr style="background-color: #cccccc;"> <td>1</td> <td>0,0000</td> <td>0,0000</td> </tr> <tr> <td>2</td> <td>0,0000</td> <td>0,0000</td> </tr> <tr> <td>3</td> <td>0,0000</td> <td>0,0000</td> </tr> <tr> <td>...</td> <td>0,0000</td> <td>0,0000</td> </tr> </tbody> </table> <p> <input type="checkbox"/> <input type="checkbox"/> : navigate within the table <input type="checkbox"/> : (for "Level" und "Value") open marked number for editing <input type="checkbox"/> : (for "No.") open row editor </p> <div style="border: 1px solid black; padding: 5px; margin: 10px 0;"> <p>Row function</p> <ul style="list-style-type: none"> - Delete row - Insert row → (before current row) - Move row → Query: new position </div>	No.	Level	Value	1	0,0000	0,0000	2	0,0000	0,0000	3	0,0000	0,0000	...	0,0000	0,0000
No.	Level	Value																													
1	0,0000	0,0000																													
2	0,0000	0,0000																													
3	0,0000	0,0000																													
...	0,0000	0,0000																													
No.	Level	Value																													
1	0,0000	0,0000																													
2	0,0000	0,0000																													
3	0,0000	0,0000																													
...	0,0000	0,0000																													
"status table"	<p>Use this parameter to enable or disable the linearization table.</p> <p>Selection</p> <ul style="list-style-type: none"> ■ Enabled The table is used. ■ Disabled The table is not used. The measured value is transferred to the output without linearization. 																														

L00-FMU90xxx-19-00-00-en-006

- 1) This option is only valid for horizontal cylinders without dome ceiling. For tanks with dome ceiling FieldCare can be used to calculate a linearization table and to upload it into the instrument.

5.5.5 Interference echo suppression: Basic principles

Parameter	Remarks
"check value" "distance mapping"	The " check value " and " distance mapping " parameters are used to configure the interference echo suppression of the Prosonic S. The following picture shows the operating principle of the interference echo suppression:

L00-FMU90xxx-19-00-00-yy-017

A The envelope curve **(a)** contains the level echo and an interference echo. Without interference echo suppression, the interference echo is evaluated.

B The interference echo suppression generates the mapping curve **(b)**. This curve suppresses all echoes within the range of mapping **(c)**.

C From now on, only those echoes are evaluated, which are higher than the mapping curve. The interference echo is below the mapping curve and is therefore ignored.



In order to include all interference echoes, the interference echo suppression should be performed with the level as low as possible. If during commissioning the vessel can not be sufficiently emptied, it is advisable to repeat the interference echo suppression at a later point of time (as soon as the level reaches nearly 0%)



71308095

www.addresses.endress.com
