

Operating Instructions

CM14

Transmitter, oxygen content

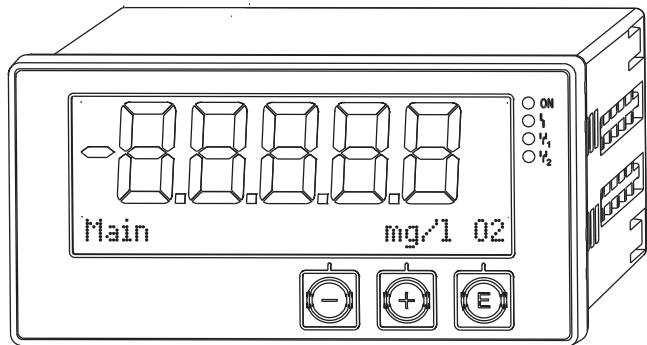

Table of contents

1	Safety instructions	4	7.2	Device functions for calibration	24
1.1	Workplace safety	4	8	Maintenance	25
1.2	Requirements concerning the staff	4	9	Accessories	26
1.3	Operational safety	4	9.1	Sensors	26
1.4	Designated use	5	10	Troubleshooting	27
1.5	Technical improvement	5	10.1	Troubleshooting instructions	27
1.6	Return	5	10.2	Diagnostic messages	27
1.7	Notes on safety conventions and icons	5	10.3	Spare parts	31
2	Identification	7	10.4	Return	31
2.1	Device designation	7	10.5	Disposal	32
2.2	Scope of delivery	7	11	Technical data	32
2.3	Certificates and approvals	8	Index	40	
3	Installation	9			
3.1	Incoming acceptance, transport, storage	9			
3.2	Installation	9			
3.3	Dimensions	9			
3.4	Installation procedure	10			
3.5	Post-installation check	10			
4	Wiring	11			
4.1	Connecting the transmitter	12			
4.2	Post-connection check	13			
5	Operation	14			
5.1	Display and device status indicator/LED	14			
5.2	Local operation at the device	14			
5.3	Icons	15			
5.4	Operating functions	16			
5.5	Hold function	16			
6	Commissioning	17			
6.1	Installation check and switching on the device	17			
6.2	Display settings (Display menu)	17			
6.3	Configuration of the device (Setup menu)	17			
6.4	Extended configuration (Extended setup menu)	18			
6.5	Device diagnostics (Diagnostics menu) .	21			
7	Calibration	22			
7.1	Definitions	23			

1 Safety instructions

Reliable and safe operation of the transmitter is guaranteed only if the user reads these Operating Instructions and complies with the safety instructions they contain.

1.1 Workplace safety

For work on and with the device:

- ▶ Wear the required personal protective equipment according to federal/national regulations.

1.2 Requirements concerning the staff

The personnel for installation, commissioning, diagnostics and maintenance must fulfill the following requirements:

- ▶ Trained, qualified specialists: must have a relevant qualification for this specific function and task
- ▶ Are authorized by the plant owner/operator
- ▶ Are familiar with federal/national regulations
- ▶ Before beginning work, the specialist staff must have read and understood the instructions in the Operating Instructions and supplementary documentation as well as in the certificates (depending on the application)
- ▶ Following instructions and basic conditions

The operating personnel must fulfill the following requirements:

- ▶ Being instructed and authorized according to the requirements of the task by the facility's owner-operator
- ▶ Following the instructions in these Operating Instructions

1.3 Operational safety

Risk of injury.

- ▶ Operate the device in proper technical condition and fail-safe condition only.
- ▶ The operator is responsible for interference-free operation of the device.

Conversions to the device

Unauthorized modifications to the device are not permitted and can lead to unforeseeable dangers.

- ▶ If, despite this, modifications are required, consult with Endress+Hauser.

Repair

To ensure continued operational safety and reliability,

- ▶ Carry out repairs on the device only if they are expressly permitted.
- ▶ Observe federal/national regulations pertaining to repair of an electrical device.
- ▶ Use original spare parts and accessories from Endress+Hauser only.

Environmental requirements

If a plastic transmitter housing is permanently exposed to certain steam and air mixtures, this can damage the housing.

- ▶ If you are unsure, please contact your Endress+Hauser Sales Center for clarification.
- ▶ If used in an approval-related area, observe the information on the nameplate.

1.4 Designated use

The transmitter evaluates measured values of an analytical sensor and displays them on its multicolor display. Processes can be monitored and controlled using the transmitter outputs and limit relays. The device is equipped with a wide range of software functions for this purpose.

- The manufacturer accepts no liability for damages resulting from incorrect use or use other than that designated. It is not permitted to convert or modify the device in any way.
- The device is designed for installation in a panel and must only be operated in an installed state.

1.5 Technical improvement

The manufacturer reserves the right to modify technical data without prior notice. Please contact your sales center for information on modifications or updates to the Operating Instructions.

1.6 Return

For a return, e.g. in case of repair, the device must be sent in protective packaging. The original packaging offers the best protection. Repairs must only be carried out by your supplier's service organization.



When returning the device for repair, enclose a note with a description of the problem and the application.

1.7 Notes on safety conventions and icons

1.7.1 Warnings



Causes (/consequences)

Consequences of non-compliance (if applicable)

- ▶ Corrective action
- ▶ This symbol alerts you to a dangerous situation. Failure to avoid the situation will result in a fatal or serious injury.



Causes (/consequences)

Consequences of non-compliance (if applicable)

- ▶ Corrective action
- ▶ This symbol alerts you to a dangerous situation. Failure to avoid the situation can result in a fatal or serious injury.

CAUTION**Causes (/consequences)**

Consequences of non-compliance (if applicable)







- ▶ Corrective action
- ▶ This symbol alerts you to a dangerous situation. Failure to avoid this situation can result in minor or more serious injuries.

NOTICE**Causes (/consequences)**

Consequences of non-compliance (if applicable)

- ▶ Corrective action
- ▶ This symbol alerts you to situations which may result in damage to property.

1.7.2 Document symbols

-  Permitted
Indicates procedures, processes or actions that are permitted.
-  Preferred
Indicates procedures, processes or actions that are preferred.
-  Forbidden
Indicates procedures, processes or actions that are forbidden.
-  Additional information, tips
-  Reference to documentation
-  Reference to a page in this manual
-  Reference to a graphic

2 Identification

2.1 Device designation

2.1.1 Nameplate

Compare the nameplate with the following diagram:

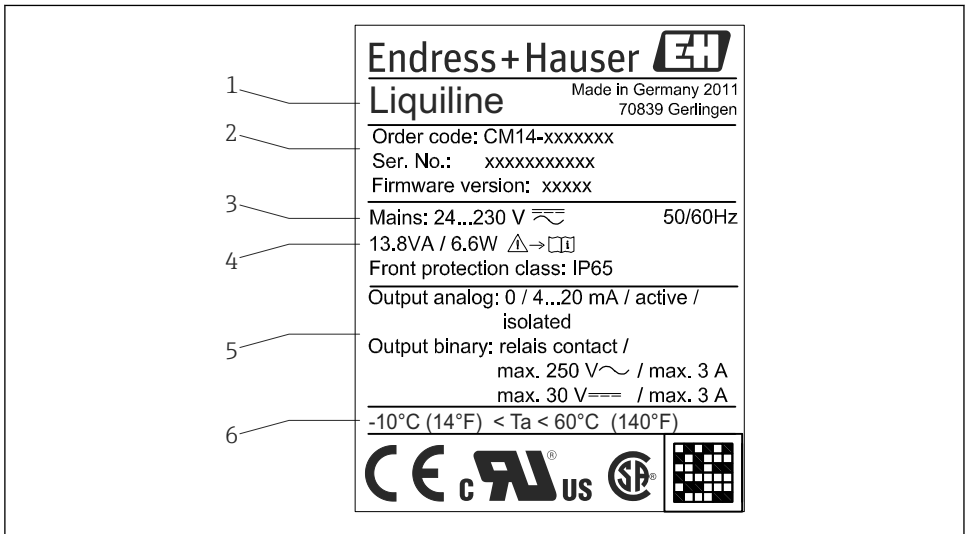

A0015221

1 Nameplate of the transmitter (example)

- 1 Device designation
- 2 Order code, serial number and ID number of the device
- 3 Power supply
- 4 Power consumption
- 5 Output values
- 6 Temperature range

2.2 Scope of delivery

The scope of delivery of the transmitter comprises:

- Transmitter for panel mounting
- Operating Instructions
- Fastening fixtures

2.3 Certificates and approvals

CE mark, Declaration of Conformity

The process display unit is designed to meet state-of-the-art safety requirements, has been tested, and left the factory in a condition in which it is safe to operate. The device complies with the applicable standards and regulations in accordance with EN 61 010-1 "Safety requirements for electrical equipment for measurement, control and laboratory use".

The device described in these Operating Instructions therefore complies with the statutory requirements of the EU Directives. The manufacturer confirms that the device has been successfully tested by applying the CE mark.

An overview of all the certificates and approvals available is provided in the "Technical data" section.

3 Installation

3.1 Incoming acceptance, transport, storage

The permitted ambient and storage conditions must be observed. The precise specifications can be found in Section "Technical data" (→  32).

3.1.1 Incoming acceptance

On receipt of the goods, check the following points:

- Are the packaging or contents damaged?
- Is anything missing from the delivery? Compare the scope of delivery with the information you specified in the order.

3.1.2 Transportation and storage

Note the following points:

- Pack the device so that is protected against impact for storage and transportation. The original packaging provides optimum protection.
- The permitted storage temperature range is -40 to $+85$ °C (-40 to $+185$ °F); it is possible to store the device in the borderline temperature ranges for a limited period (maximum 48 hours).

3.2 Installation

NOTICE

Overheating due to heat accumulation in the device

- ▶ To avoid heat accumulation, please always make sure the device is sufficiently cooled.



If the device is operated in the upper temperature limit range, this reduces the operating life of the display.

The transmitter is designed to be used in a panel.

The orientation is determined by the readability of the display. Connections and outputs are fitted on the rear of the device. The wires are connected by means of number-coded terminals.

Ambient temperature range: -10 to $+60$ °C (14 to 140 °F)

3.3 Dimensions

Observe the installation depth of 150 mm (5.91 ") for the device incl. terminals and fastening clips.

More dimensions can be found in Section "Technical data" (→  32).

- Panel cutout: 92 mm x 45 mm (3.62 in x 1.77 in).
- Panel thickness: max. 26 mm (1 in).
- Max. viewing angle range: 45° to the left and right from the central display axis.
- If the devices are arranged horizontally beside one another in the X-direction, or arranged vertically on top of one another in the Y-direction, the mechanical distance (specified by the housing and front section) must be observed.

3.4 Installation procedure

The required panel cutout is 92 mm x 45 mm (3.62 in x 1.77 in).

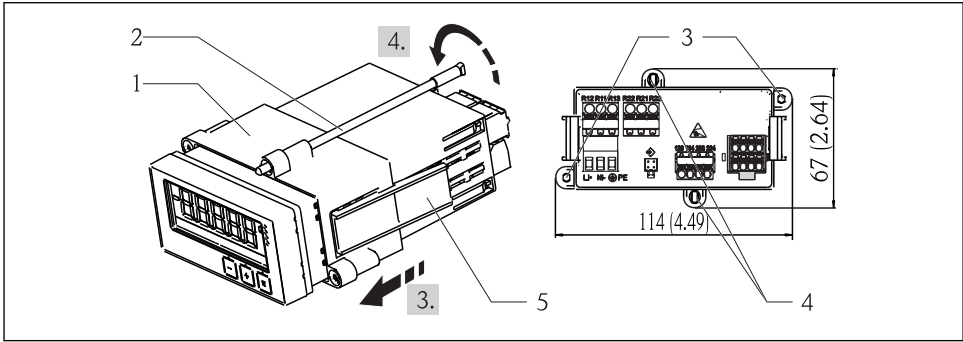

A0015216

2 Installation in the panel

1. Screw the threaded rods (item 2) into the positions provided on the mounting frame (item 1). Four opposing screw positions (item 3/4) are available for this purpose.
2. Push the device with the sealing ring through the panel cutout from the front.
3. To secure the tube in the panel, hold the device in a horizontal position and push the installation frame (item 1), with the threaded rods screwed in, over the tube until the frame locks into position.
4. Tighten the threaded rods to fasten the device in place.

To disassemble the device, the mounting frame can be unlocked at the locking elements (item 5) and then removed.

3.5 Post-installation check

- Is the sealing ring undamaged?
- Is the mounting frame securely engaged on the housing of the device?
- Are the threaded rods tightened?
- Is the device positioned in the center of the panel cutout?

4 Wiring

WARNING

Danger from electrical voltage

- ▶ The entire connection of the electrical system must take place while the device is de-energized.

Danger if protective ground is interrupted

- ▶ The protective ground connection must be established before any other connection is made.

NOTICE

Thermal load of the lines

- ▶ Use suitable lines for temperatures of 5 °C (9 °F) above ambient temperature.

Malfunction or destruction of the device due to incorrect supply voltage

- ▶ Prior to commissioning, make sure the supply voltage matches the specifications on the nameplate (bottom side of the housing).

Ensure the emergency shutoff of the device

- ▶ Provide a suitable switch or power-circuit breaker in the building installation. This switch must be provided within easy reach of the device and be labeled as a disconnecter.

Protect device from overload

- ▶ Provide a overload protection unit (rated current = 10 A) for the power supply line.

Incorrect wiring can cause destruction of the device

- ▶ Observe the terminal designation on the rear of the device.

Energy-rich transients in long signal lines

- ▶ Connect suitable upstream overvoltage protection in series.



It is permitted to connect a mixture of safety extra low voltage and voltage which poses a shock hazard to the relays.

4.1 Connecting the transmitter

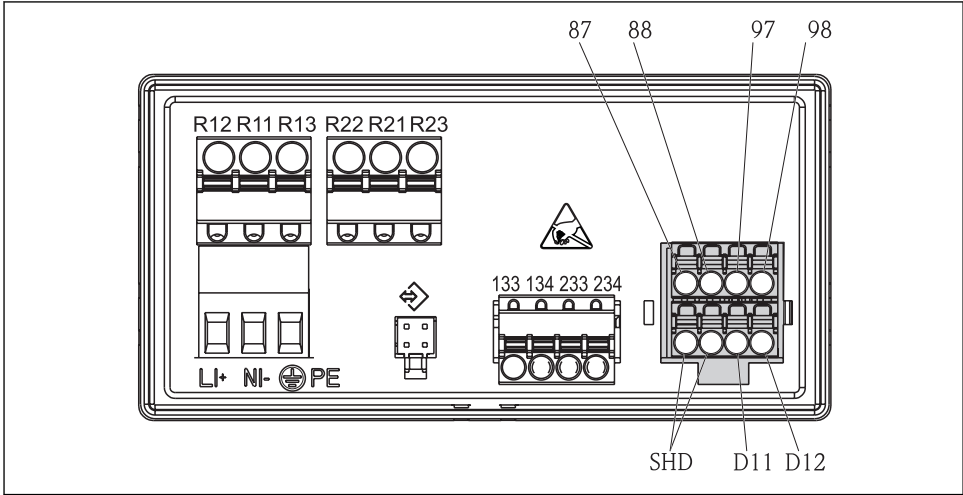



A0015215

3 Connection diagram of the transmitter

Terminal	Description
87	Terminal for Memosens cable, brown, sensor power supply U+
88	Terminal for Memosens cable, white, sensor power supply U-
97	Terminal for Memosens cable, green, Com A
98	Terminal for Memosens cable, yellow, Com B
SHD	Terminal for Memosens cable, shield
D11	Terminal for alarm output, +
D12	Terminal for alarm output, -
L/+	Terminal for transmitter supply voltage
N/-	
⊕ PE	
133	Terminal for analog output 1, +
134	Terminal for analog output 1, -
233	Terminal for analog output 2, +
234	Terminal for analog output 2, -
R11, R12, R13	Terminal for relay 1
R21, R22, R23	Terminal for relay 2

4.2 Post-connection check

Device condition and specifications	Notes
Are the device or cables damaged?	Visual inspection
Electrical connection	Notes
Does the supply voltage match the specifications on the nameplate?	24 to 230 V AC/DC (-20 % / +10 %) 50/60 Hz
Are all of the terminals firmly engaged in their correct slots? Is the coding on the individual terminals correct?	-
Are the mounted cables strain-relieved?	-
Are the supply voltage and signal cables connected correctly?	See connection diagram, (→  3,  12) and on the housing.

5 Operation

The easy operating concept of the device makes it possible for users to commission the device for many applications without a printed set of Operating Instructions.

5.1 Display and device status indicator/LED

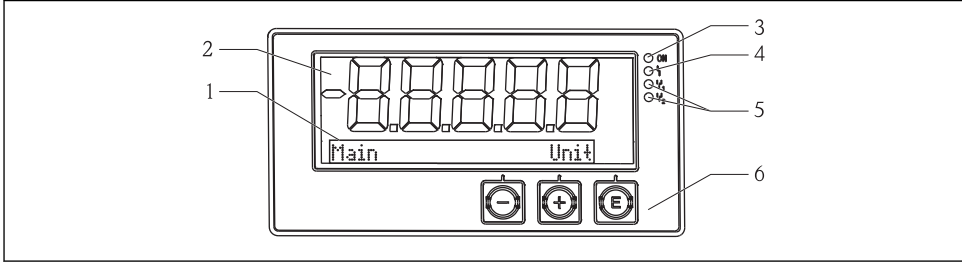

A0015891

4 Display of the device

- 1 Dot-matrix section
- 2 7-segment section
- 3 LED status indicator power supply connected
- 4 LED status indicator alarm function
- 5 LED status indicator limit function relay 1/2
- 6 Operating keys

The device provides a backlit LC display which is split into two sections. The segment section shows the measured value.

In the dot matrix section, additional channel information, such as the TAG, unit or bar graph, is shown in display mode. Operating text in English is displayed here during operation.

The parameters for configuring the display are explained in detail in Section Commissioning.

In the event of an error, the device switches automatically between displaying the error and displaying the channel, see Sections Device diagnostics (→ 21) and Troubleshooting (→ 27).

5.2 Local operation at the device

The device is operated by means of the three keys integrated in the front part of the device



A0010420



A0010421

- Open the configuration menu
- Confirm an entry
- Select a parameter or submenu offered in the menu



A0010422

Within the configuration menu:

- Scroll step-by-step through the parameters/menu items/characters offered
- Change the value of the selected parameter (increase or decrease)

Outside the configuration menu:



Display enabled and calculated channels, as well as min. and max. values for all the active channels.

You can always exit items/submenus at the end of the menu by selecting "x Back".

Leave the setup directly without saving the changes by pressing the '-' and '+' keys simultaneously for over 3 s seconds.

5.3 Icons

5.3.1 Display icons

	Hold function (→  16) aktiv.
Max	Maximum value/value of the maximum indicator of the channel displayed.
Min	Minimum value/value of the minimum indicator of the channel displayed.
-----	Error, under/over range. No display of the measured value.



In the dot matrix section, the error and the channel name (TAG) are specified.





5.3.2 Icons in the editing mode

The following characters can be used to enter user-defined text:

'0-9', 'a-z', 'A-Z', '+', '-', '*', '/', '\', '%', '^', '2', '3', 'm', ':', ';', ',', '.', '!', '?', '_', '#', '\$', '"', "'", '(', ')', '~',

For numerical entries, the numbers '0-9' and the decimal point are available.

Furthermore, the following icons are used in the editing mode:

	Symbol for the setup
	Symbol for the Expert setup
	Symbol for diagnostics
	Accept entry. If this icon is selected, the information entered is accepted at the position and the user exits the editing mode.
	Reject entry. If this icon is selected, the information entered is rejected and the user exits the editing mode. The text configured beforehand remains unchanged.

- ← Move one position to the left.
 If this icon is selected, the cursor moves one position to the left.

- ⌫ Delete back.
 If this icon is selected, the character to the left of the cursor is deleted.

- ☒ Delete all.
 If this icon is selected, all the information entered is deleted.

5.4 Operating functions

The operating functions of the transmitter are organized into the following menus:

Display	Adjusting the device display: contrast, brightness, switching time for displaying the measured values
Setup	Device settings For descriptions of the individual settings, refer to the chapter on Commissioning (→  17).
Calibration	Carrying out the sensor calibration For descriptions of the calibration functions, refer to the chapter on Calibration.
Diagnostics	Device information, diagnostic logbook, sensor information, simulation

5.5 Hold function

The effect of the Hold function is to "freeze" the current outputs and relay states. It can be switched on or off manually (menu **Setup**→**Manual hold**). Furthermore, the Hold function is automatically activated during sensor calibration.



The Hold function remains active after discontinuation of the hold condition for an adjustable Hold-release time. The Hold-release time can be set under **Setup**→**Extended setup**→**System**→**Hold release**.

The measured value display is not affected by the Hold function. The Hold symbol is displayed behind the measured value.

6 Commissioning

6.1 Installation check and switching on the device

Make sure that all post-connection checks have been carried out before you commission your device:

- "Installation check" checklist, (→  10).
- "Post-connection check" checklist, (→  13).

Once the operating voltage is applied, the green LED lights up and the display indicates that the device is operational.

When you commission the device for the first time, you program the setup in accordance with the descriptions provided in these Operating Instructions in the following sections.

When commissioning a device already configured or preset, measuring is immediately started as per the settings. The values of the channels currently activated appear on the display.



Remove the protective foil from the display as this restricts display legibility otherwise.

6.2 Display settings (Display menu)

Call up the main menu by pressing the 'E' button during operation. The Display menu appears in the display. Pressing the 'E' key again opens this menu. Select the "x Back" option to navigate one level higher in the menu structure at the end of each menu/submenu.

Parameter	Configuration options	Description
Contrast	1-7 Default: 6	Configures the display contrast.
Brightness	1-7 Default: 6	Configures the display brightness.
Alternating time	0, 3, 5, 10 sec	Switching time between the two measured values. 0 means no switching.

6.3 Configuration of the device (Setup menu)

Call up the main menu by pressing the 'E' button during operation. Use the '+' and '-' buttons to navigate through the available menus. When the desired menu is displayed, press the 'E' key to open the menu. Select the "x Back" option to navigate one level higher in the menu structure at the end of each menu/submenu.

The Setup menu includes the most important settings for the function of the device.

Parameter	Configuration options	Description
Current range	4-20 mA 0-20 mA	Configure the measuring range for the current output.
Out 1 0/4 mA	Numerical value 0.000 to 99999 0.0 mg/l	Physical value corresponding to the lower range limit of the analog output. If the set value is undershot, the current output goes to the saturation current 0/3.8 mA.
Out 1 20 mA	Numerical value -0.02 to 120 120 mg/l	Physical value corresponding to the upper range limit of the analog output. If the set value is exceeded, the current output goes to the saturation current 20.5 mA.
Out 2 0/4 mA	Numerical value -50 to 250 °C 0 °C	Temperature corresponding to the measuring range lower limit of the temperature input. If the set value is undershot, the current output goes to the saturation current 0/3.8 mA.
Out 2 20 mA	Numerical value -50 to 250 °C 100 °C	Temperature corresponding to the measuring range upper limit of the temperature input. If the set value is exceeded, the current output goes to the saturation current 20.5 mA.
Damping main value	0 to 60 s 0 s	Configure the damping for the low-pass filtering of the input signals.
Extended setup		Advanced settings for the device, such as the relay, limit values etc. The functions are described in the following chapter, (→ 18).
Manual hold	Off, On	Function to hold the current and relay outputs

6.4 Extended configuration (Extended setup menu)

Call up the main menu by pressing the 'E' button during operation. Use the '+' and '-' buttons to navigate through the available menus. When the desired menu is displayed, press the 'E' key to open the menu. Select the "x Back" option to navigate one level higher in the menu structure at the end of each menu/submenu.

Parameter	Configuration options	Description
System		General settings
Tag	Customized text, max. 16 characters A	Enter the device designation (tag).
Temp. Unit	°C °F	Configures the temperature unit.
Hold release	0 to 600 s 0 s	Configuration that specifies how long a device hold continues once the hold condition no longer applies.

Parameter		Configuration options	Description	
	Alarm delay	0 to 600 s 0 s	Delay time for issuing an alarm. This suppresses alarm conditions that occur for a period shorter than the alarm delay time.	
Input			Settings of the device	
	Main value	Conc. liquid Partial pressure	Setting to specify the medium in which measurement is performed. Conc. liquid for aqueous media and Partial pressure for measurements in the gas phase	
	Unit	mg/l , $\mu\text{g/l}$, ppm, ppb - if Conc. liquid has been selected hPa - if Partial pressure has been selected	Unit of the physical value.	
	Format	none, one, two	Configure the number of decimal places for the display.	
	Damping main	0 to 60 s 0 s	Configure the damping for the low-pass filtering of the input signals.	
	Medium pressure	Altitude Air pressure	Setting for altitude or air pressure.	
	Altitude	-300 to 4 000 m 0 m	Altitude is set if Medium Pressure → Altitude has been selected.	
	Air pressure	500 to 9999 mbar 1013 mbar	Air pressure is set if Medium Pressure → Air pressure has been selected.	
	Stability crit.		Conditions for successful calibration. Calibration is not permitted and is canceled automatically if the permitted difference is exceeded.	
		Delta signal	0.10 to 2 % 2 %	Permitted measured value fluctuation during calibration
		Delta temp	0.1 to 2 K 0.50 K	Maximum permitted fluctuation in temperature
		Duration	5 to 60 s 5 s	Timeframe within which the permitted measured value fluctuation may not be exceeded
		Process check		Check the process settings.
		Function	On, Off	Switch on the process check.
	Duration	1 to 240 min 60 min	Duration of the process check.	
	Tolerance	0.01 to 20 hPa 0.01 hPa	Bandwidth for the process check.	
	Calib. Settings		This pressure value is used during the calibration for correct calculation.	

Parameter		Configuration options	Description
	Medium press.	Air pressure Altitude	Use of the altitude or air pressure.
	Air pressure	500 to 9999 mbar 1013 mbar	Air pressure is set if Medium Press. → Air pressure has been selected.
	Altitude	-300 to 4000 m 0 m	Altitude is set if Medium Press. → Altitude has been selected.
Analog outputs			Settings for analog outputs.
	Current range	4-20 mA 0-20 mA	Current span for analog output.
	Out 1 0/4 mA	Numerical value 0.000 to 99999 0.0 mg/l O₂	Physical value corresponding to the lower range limit of the analog output.
	Out 1 20 mA	Numerical value 0.000 to 99999 120 mg/l O₂	Physical value corresponding to the upper range limit of the analog output.
	Out 2 0/4 mA	Numerical value -50 to 250 °C 0 °C	Temperature corresponding to the measuring range lower limit of the temperature input.
	Out 2 20 mA	Numerical value -50 to 250 °C 100 °C	Temperature corresponding to the measuring range upper limit of the temperature input.
Relay 1/2			Settings for the relay outputs.
	Function	Off , Min limit, Max limit, In band, Out band, Error	Configure the function of the relay. No additional settings are possible in the event of function = Error .
	Assignment	Main , Temp	Assign the relay to the main or temperature input.
	Set point	Numerical value 0.0	Configures the limit value.
	Set point 2	Numerical value 0.0	Only for function In band or Out band .
	Hyst.	Numerical value 0.0	Configures the hysteresis.
	Delay time	0 to 60 s 0 s	Configure the delay until the relay switches.
Factory default			Reset the device settings to the factory settings.
	Please confirm	no , yes	Confirm reset.

6.4.1 Configuration of the relays

The device has two relays with limit values that are either switched off or can be allocated to the input signal. The limit value is entered as a numerical value including the position of the decimal point. The way the changeover contact is wired ((→  34)) determines whether the relays act as an NO or NC relay. Limit values are always assigned to a relay. Each relay can

be assigned a channel or calculated value. In "Error" mode, the relay acts as an alarm relay and switches for each error or alarm.

The following settings can be made for each of the two limit values: assignment, limit, hysteresis, switching behavior, delay and fault mode.

6.5 Device diagnostics (Diagnostics menu)

Call up the main menu by pressing the 'E' button during operation. Use the '+' and '-' buttons to navigate through the available menus. When the desired menu is displayed, press the 'E' key to open the menu. Select the "x Back" option to navigate one level higher in the menu structure at the end of each menu/submenu.

Parameter		Configuration options	Description
Current diag.		Read only	Display the current diagnostic message
Last diag.		Read only	Display the last diagnostic message
Diagnost logbook		Read only	Display the last diagnostic messages
Device info		Read only	Display device information
	Device tag	Read only	View the device designation
	Device name	Read only	Display the device name
	Serial number	Read only	Displays the serial number of the device
	Order code	Read only	Displays the order code of the device
	FW revision	Read only	Display the firmware version
	ENP version	Read only	Display the version of the electronic type plate
	Module ID	Read only	Display the module ID
	Manufact. ID	Read only	Display the manufacturer's ID
	Manufact. name	Read only	Display the manufacturer name
Sensor info			
	General info		General sensor information
		Order code	Displays the order code of the sensor
		Serial number	Displays the serial number of the sensor
		Device tag	Displays the tag name of the sensor
		FW version	Displays the firmware version
		HW version	Displays the hardware version
	Operation time		Operating time
		Operation time > 40 °C	Operating time over 40 °C
		Operation time > 80 °C	Operating time over 80 °C

Parameter		Configuration options	Description
	Sterile counter		The system counts the number of operating hours in which the sensor is exposed to a temperature that is typical for a sterilization. This temperature depends on the sensor.
Calibration info			Calibration data of the last calibration
	Cal. count		Number of sensor calibrations
	Slope in pA/hPA		The (relative) slope characterizes the sensor condition.
	Delta slope		Difference in slope between the last and second-last calibration
	Temp. cal offset		
	Zero point		The zero point corresponds to the sensor signal that is measured in a medium in the absence of oxygen.
Specification			Information on the sensor specification
	Min 0.0 hPa		
	Max 200 hPa		
	Min Temp. -5.00 °C		
	Max Temp 135 °C		
Simulation:			Certain values can be simulated for test purposes at the inputs and outputs.
	Analog Out 1		
	Analog Out 2		
	Relay 1		
	Relay 2		
	Alarm out		
Reset device			Reset the sensor to factory defaults.

7 Calibration

Calibrate the sensor directly after polarization.

1. Remove the sensor from the medium.
2. Clean the outside of the sensor using a damp cloth. Then dry the sensor diaphragm carefully using a paper towel for example.

3. Wait approx. 20 minutes for the sensor to adapt to the temperature of the ambient air. The sensor may not be exposed to harsh sunlight during this time.
4. Once the measured value displayed at the transmitter has stabilized, perform the calibration as described in the Operating Instructions.
5. Then re-immerses the sensor in the medium.

7.1 Definitions

7.1.1 Polarization

A fixed voltage is applied between the cathode and anode when the sensor is connected to the transmitter. The polarization current which this creates is indicated at the transmitter by a value that is initially high but gradually decreases. The value displayed must first stabilize before the sensor can be calibrated.

7.1.2 Calibration

During a calibration, the operator adapts the transmitter to the characteristic values of the sensor.

Normally, the sensor hardly ever needs to be calibrated. Calibration is necessary:

- After initial commissioning
- After replacing the membrane or electrolyte
- After cleaning the cathode
- Following extended operating intervals without power being supplied

The calibration can be checked cyclically or reperformed during plant monitoring routines (at typical intervals depending on experience with operating conditions).

Calibration

You can perform two kinds of calibration: slope or zero point

Both kinds of calibration can be performed individually or in succession. If you perform both kinds of calibration, you end up with the one to which your measurement is closest.

Slope

The (relative) slope characterizes the sensor condition. Decreasing values indicate that the electrolyte is being used up. You can control when the system prompts the user to change the electrolyte by specifying limit values which cause the system to trigger diagnostics messages.

A calibration of the slope in water vapor-saturated air is performed as follows:

1. Press "E" to call up the main menu.
2. Press the "+" button to navigate to the "Calibration" menu.
3. Press "E" to open the menu.
 - ↳ Select "Slope Air 100%"
4. Press "E" to open the menu.
 - ↳ The display shows the current slope that might be changed by the calibration.
5. Press "+".

- ↳ Display reads "Keep sensor above water"
- 6. Clean and dry the sensor and position it very close to the water.
- 7. Press "+".
- 8. Display reads "wait for stable value". When the value is stable, the display changes.
 - ↳ Display reads "O2 cal air"
- 9. Press "+".
 - ↳ Display reads "Save Calib. Data?"
- 10. Press "+".
 - ↳ Display reads "Calib. successful"
- 11. Press "+".

Back to measuring mode.

A calibration of the zero point in oxygen-free medium (nitrogen grade N5 or sodium sulfite solution) is performed as follows:

1. Press "E" to call up the main menu.
2. Press the "+" button to navigate to the "Calibration" menu.
3. Press "E" to open the menu.
4. Press "+" to switch to "Zero point calib."
5. Press "E" to open the menu.
 - ↳ The display shows the current zero point in nA. This can change on account of the calibration.
6. Press "+".
 - ↳ Display reads "Waiting for sensor in medium"
7. Immerse the sensor in the medium.
8. Press "+".
9. Display reads "wait for stable value". When the value is stable, the display changes.
 - ↳ Display reads "Zero point"
10. Press "+".
 - ↳ Display reads "Save Calib. Data?"
11. Press "+".
 - ↳ Display reads "Calib. successful"
12. Press "+".

Back to measuring mode.

7.2 Device functions for calibration

Press the 'E' button during operation to call up the main menu. Use the '+' and '-' buttons to navigate through the available menus. When the desired menu is displayed, press the 'E' key

to open the menu. Select the "x Back" option at the end of each menu/submenu to navigate one level higher in the menu structure.

Parameter		Configuration options	Description
DO			Calibration of dissolved oxygen measurement
	Slope air 100 %	Read only	Name of DO calibration method
	O2 (act) in %	Read only	Displays the current DO value as % saturation
	O2 cal air in %	Read only	Displays the DO value in air as %
	Save calib data?	Yes, No	Save or discard calibration data?
Temperature			Calibrate the temperature measurement.
	T cal. start	Read only	
	T cal.	Numerical value	
	Save calib data?	Yes, No	Save or discard calibration data?

8 Maintenance

No special maintenance work is required on the device.

9 Accessories

9.1 Sensors

Oxygen sensors

Oxymax COS51D

- Amperometric sensor for dissolved oxygen, with Memosens technology
- Order as per product structure, see Technical Information TI00413C/07/en

10 Troubleshooting

The following section provides you with an overview of possible causes of errors to provide you with an initial troubleshooting aid.

10.1 Troubleshooting instructions

WARNING

Danger from electrical voltage

- ▶ Do not operate the device for troubleshooting purposes while it is open!

Display	Cause	Remedy
No measured value display	No power supply connected	Check the power supply of the device.
	Power supply applied, device defective	The device must be replaced.
Diagnostic message is displayed	For the list of diagnostic messages, refer to the following section.	

10.2 Diagnostic messages

The diagnostics message comprises a diagnostics code and message text.

The diagnostics code is made up of the error category as per Namur NE 107 and the message number.

Error category (letter in front of the message number)

- F = Failure. A malfunction has been detected.
The measured value of the specific channel is no longer reliable. The cause of the malfunction should be sought in the measuring point. If a controller is connected, this should be set to manual mode.
- M = Maintenance required. Action may have to be taken soon.
The device stills measures correctly. Immediate measures must not be taken. However, proper maintenance efforts would prevent a possible malfunction in the future.
- C = Function check. (No error).
Maintenance work is being performed on the device. Wait until the work has been completed.
- S = Out of specification. The measuring point is being operated outside specifications. Operation is still possible. However, you run the risk of increased wear, a shorter operating life or lower accuracy levels. The cause of the problem should be sought outside the measuring point.

Sample display:

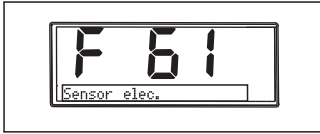

A0015896

F 61
sensor elec.

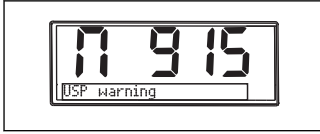

A0015897

M 915
USP warning



A0015898

S 844
Process value



A0015899

C 107
Calib. active

Error code	Message	Description
F5	Sensor data	Sensor data invalid. Remedy: <ul style="list-style-type: none"> ▪ Update date of the transmitter ▪ Replace sensor
F12	Writing data	The sensor data could not be written. Remedy: <ul style="list-style-type: none"> ▪ Repeat writing of the sensor data ▪ Replace sensor
F13	Sensor type	Incorrect sensor type. Remedy: Switch to a sensor of the configured type.
F61	Sensor elec.	Sensor electronics defective. Remedy: <ul style="list-style-type: none"> ▪ Replace sensor ▪ Contact service
F62	Sens. Connect	Sensor connection. Remedy: <ul style="list-style-type: none"> ▪ Replace sensor ▪ Contact service

Error code	Message	Description
F100	Sensor comm.	<p>No sensor communication.</p> <p>Possible reasons:</p> <ul style="list-style-type: none"> ▪ No sensor connection ▪ Faulty sensor connection ▪ Short-circuit in the sensor cable ▪ Short-circuit in the neighboring channel ▪ Sensor firmware update canceled with an error <p>Remedy:</p> <ul style="list-style-type: none"> ▪ Check sensor cable connection ▪ Check sensor cable for short-circuit ▪ Replace sensor ▪ Restart firmware update ▪ Contact service
F130	Sensor supply	<p>Sensor check.</p> <p>Poor energy supply to sensor.</p> <p>Remedy:</p> <ul style="list-style-type: none"> ▪ Check cable connections ▪ Replace sensor
F143	Self test	<p>Sensor self-test error.</p> <p>Remedy:</p> <ul style="list-style-type: none"> ▪ Replace sensor ▪ Contact service
F845	Device id	Faulty hardware configuration
F846	Param error	<p>Faulty parameter checksum</p> <p>Possible cause:</p> <p>Firmware update</p> <p>Remedy:</p> <p>Reset parameters to factory defaults</p>
F847	Couldn't save param	Parameters could not be saved
F848	Calib AO1	Faulty calibration values for analog output 1
F849	Calib AO2	Faulty calibration values for analog output 2
F904	Process check	<p>Process check system alarm.</p> <p>No change in measurement signal for a long time.</p> <p>Possible reasons</p> <ul style="list-style-type: none"> ▪ Sensor dirty or in air ▪ No sensor inflow ▪ Sensor defective ▪ Software error <p>Remedy:</p> <ul style="list-style-type: none"> ▪ Check measuring chain ▪ Inspect sensor ▪ Carry out software restart

Error code	Message	Description
C107	Calib. active	Sensor calibration is active. Remedy: Wait for calibration
C154	No calib. data	Sensor data. No calibration data present, factory settings will be used. Remedy: <ul style="list-style-type: none"> ▪ Check calibration information of the sensor ▪ Calibrate cell constant
C850	Simu AO1	Simulation of analog output 1 is active
C851	Simu AO2	Simulation of analog output 2 is active
C852	Simu DO	Simulation of status output is active
C853	Download act.	Parameter transmission is active

Error code	Message	Description
S844	Process value	Measured value outside the specified range. Measured value outside the specified range. Possible reasons: <ul style="list-style-type: none"> ▪ Sensor in air ▪ Air cushion in the assembly ▪ Incorrect sensor inflow ▪ Sensor defective Remedy: <ul style="list-style-type: none"> ▪ Increase process value ▪ Check measuring chain ▪ Change sensor type
S910	Limit switch	Limit switch energized

Error code	Message	Description
M126	Sensor check	Sensor check. Bad electrode status. Possible reasons: <ul style="list-style-type: none"> ▪ Glass membrane blocked or dry ▪ Junction blocked Remedy: <ul style="list-style-type: none"> ▪ Clean sensor and regenerate ▪ Replace sensor

10.3 Spare parts

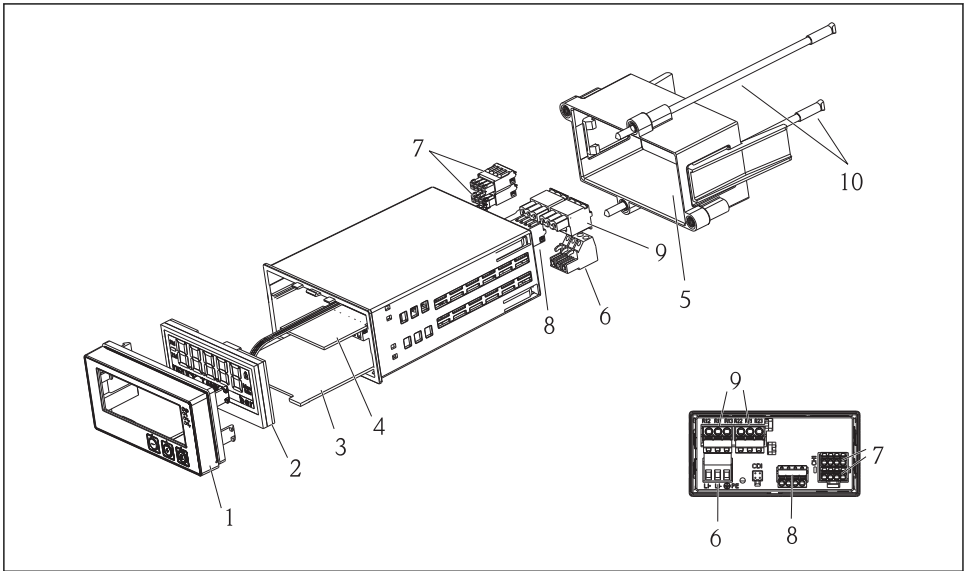

A0015745

5 Spare parts of the device

Item no.	Description	Order no.
1	Housing front + foil, incl. keyboard CM14, without display	XPM0004-DA
2	CPU/Display board CM14 DO amperometric	XPM0004-CO
3	Mainboard 24-230VDC/AC, CM14	XPM0004-NA
4	Relay board + 2 limit relays	RIA45X-RA
5	Fixing frame for housing W07	71069917
6	Terminal, 3-pole (power supply)	50078843
7	Pluggable terminal, 4-pole (Memosens input)	71037350
8	Pluggable terminal, 4-pole (current output)	71075062
9	Pluggable terminal, 3-pole (relay terminal)	71037408
10	Threaded bar for tube fixing clip 105mm	71081257

10.4 Return

For a return, e.g. in case of repair, the device must be sent in protective packaging. The original packaging offers the best protection. Repairs must only be carried out by your supplier's service organization.

 Please enclose a note describing the fault and the application when sending the unit in for repair.

10.5 Disposal

The device contains electronic components and must, therefore, be disposed of as electronic waste in the event of disposal. Please observe in particular the local waste disposal regulations of your country.

11 Technical data

11.1 Input

11.1.1 Measured variables

--> Documentation of the connected sensor

11.1.2 Measuring ranges

--> Documentation of the connected sensor

11.1.3 Input types

Digital sensor inputs, Memosens and Memosens protocol

11.1.4 Cable specification

Cable type

Memosens data cable or fixed sensor cable, each with cable end sleeves

Cable length

Max. 100 m (330 ft)

11.2 Output

11.2.1 Output signal

2 x 0/4 to 20 mA active, potentially isolated from the sensor circuits and from each other

11.2.2 Load

Max. 500 Ω

11.2.3 Linearization/transmission behavior

Linear

11.2.4 Alarm output

The alarm output is designed as an "open collector." In normal operation the alarm output is closed. In the event of a fault (F-fault, device without current) the "open collector" opens.

Current max.	200 mA
Voltage max.	30 V DC

11.3 Current outputs, active

11.3.1 Span

0 to 23 mA

11.3.2 Signal characterization

Linear

11.3.3 Electrical specification

Output voltage

Max. 24 V

11.3.4 Cable specification

Cable type

Recommendation: shielded line

Cross-section

Max. 1.5 mm² (16 AWG)

11.4 Relay outputs

11.4.1 Relay types

2 changeover contacts

11.4.2 Relay switching capacity

Max. 3 A24 V DC

Max. 3 A253 V AC

Min. 100 mW (5 V / 10 mA)

11.4.3 Cable specification

Cross-section

Max. 2.5 mm² (14 AWG)

11.5 Wiring

11.5.1 Electrical connection

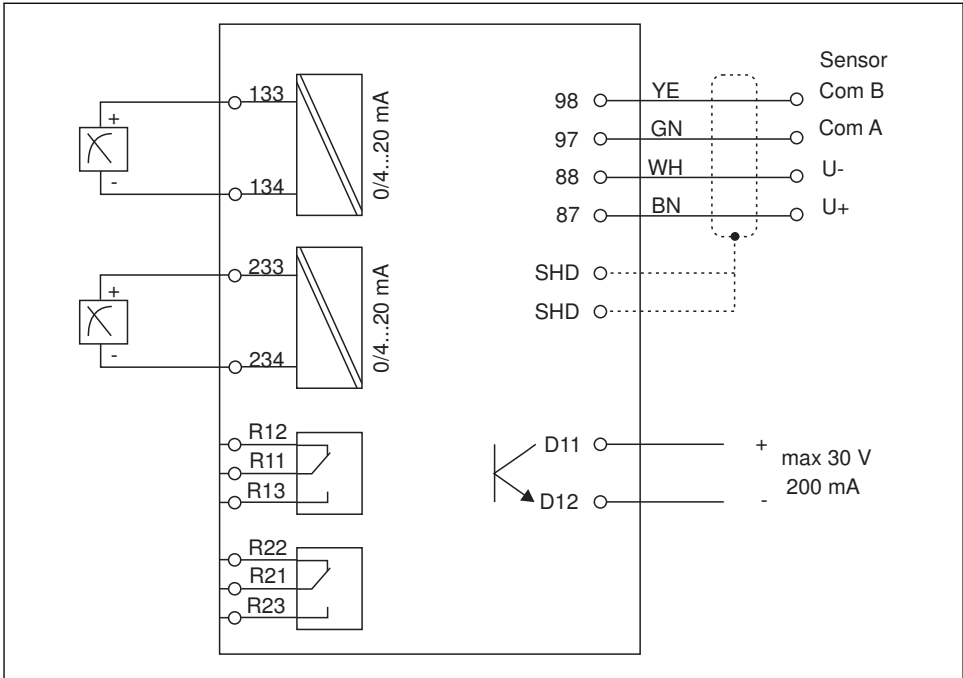

A0015303

Connection	Description
87	Terminal for Memosens cable, brown, sensor power supply U+
88	Terminal for Memosens cable, white, sensor power supply U-
97	Terminal for Memosens cable, green, Com A
98	Terminal for Memosens cable, yellow, Com B
SHD	Terminal for Memosens cable, shield
D11	Terminal for alarm output, +
D12	Terminal for alarm output, -
L/+	Terminal for transmitter supply voltage
N/-	
⊕PE	
133	Terminal for analog output 1, +

Connection	Description
134	Terminal for analog output 1, -
233	Terminal for analog output 2, +
234	Terminal for analog output 2, -
R11, R12, R13	Terminal for relay 1
R21, R22, R23	Terminal for relay 2

11.5.2 Supply voltage

Wide-range power supply 24 to 230 V AC/DC (-20 % / +10 %) 50/60Hz



The device does not have a power switch

- The customer has to provide a protected circuit breaker close to the device.
- The disconnecter must be a switch or power-circuit breaker and must be identified as a disconnecter for the device.

11.5.3 Power consumption

Max. 13.8 VA / 6.6 W

11.6 Performance characteristics

11.6.1 Response time

Current outputs

t_{90} = max. 500 ms for a jump from 0 to 20 mA

11.6.2 Reference temperature

25 °C (77 °F)

11.6.3 Maximum measured error of inputs

--> Documentation of the connected sensor

11.6.4 Resolution of current output

> 13 bit

11.6.5 Repeatability

--> Documentation of the connected sensor

11.7 Installation conditions

11.7.1 Installation instructions

Mounting location

Panel, cutout 92 x 45 mm (3.62 x 1.77 in)

Max. panel thickness 26 mm (1 in)

Orientation

The orientation is only determined by the legibility of the display.

Max. viewing angle +/- 45° in every direction from the central axis of the display.

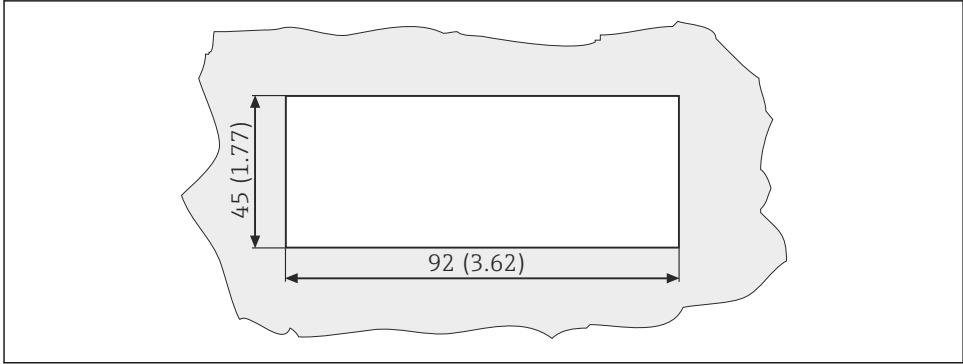

A0010351

6 Panel cutout, dimensions in mm (in)

11.8 Environment

11.8.1 Ambient temperature range

-10 to +60 °C (14 to 140 °F)

11.8.2 Storage temperature

-40 to +85 °C (-40 to +185 °F)

11.8.3 Operating height

< 2 000 m (6 561 ft) above MSL

11.8.4 Electromagnetic compatibility

Emitted interference and interference immunity to EN 61326-1:2006, Class A for industrial areas

11.8.5 Degree of protection

Front

Front IP65 / NEMA 4X

Tube

Shock protection IP20

11.8.6 Relative humidity

5 to 85 %, non-condensing

11.9 Mechanical construction

11.9.1 Dimensions

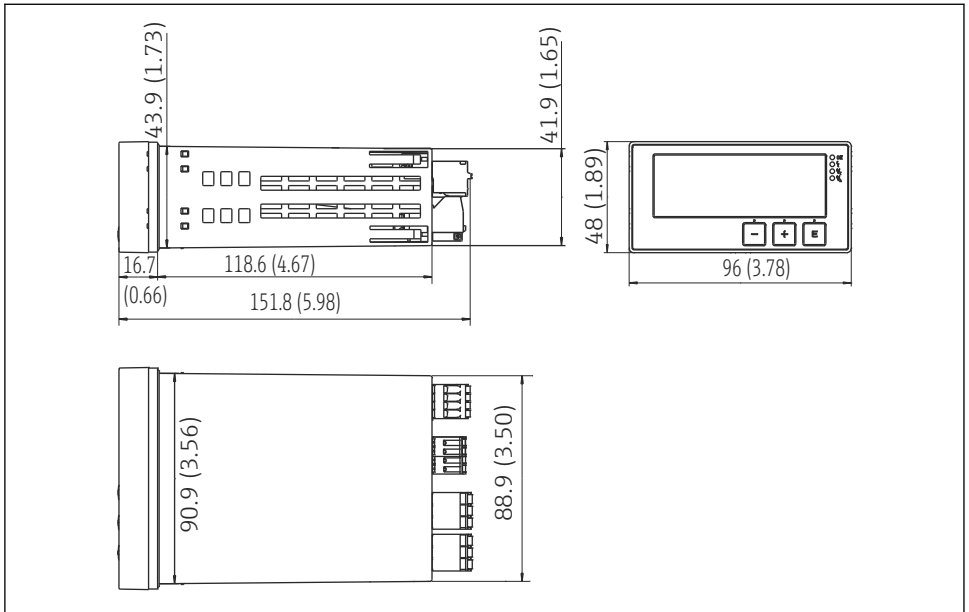

A0015925

7 *Dimensions of the transmitter in mm (in)*

11.9.2 Weight

0.3 kg (0.66 lbs)

11.9.3 Materials

Housing, casing:	Polycarbonate
Front membrane:	Polyester, UV-resistant

11.9.4 Terminals

Max. 2.5 mm² (22-14 AWG; tightening torque 0.4 Nm (3.5 lb in)) mains, relay

11.10 Display and operating elements

11.10.1 Operating elements

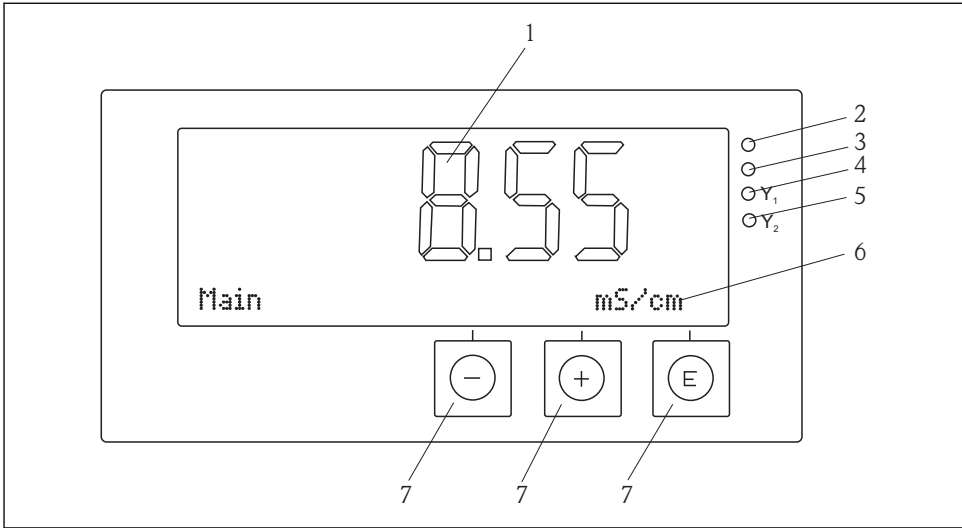

A0018699

8 Display and operating elements

- 1 LC display for measured values and configuration data
- 2 Status LED power supply connected
- 3 Status LED alarm function
- 4 Status LED limit function relay 1
- 5 Status LED limit function relay 2
- 6 Dot matrix display for dimensions and menu items
- 7 Operating keys

11.11 Certificates and approvals

11.11.1 CE mark

Declaration of Conformity

The product fulfills the requirements of harmonized European standards.

Thus it fulfills the legal requirements of the EC Directives.

The manufacturer confirms successful testing of the device by affixing to it the **CE** mark.

Other standards and guidelines

- IEC 60529:
Degree of protection by housing (IP code)
- IEC 61010-1: 2001 Cor 2003
Safety requirements for electrical equipment for measurement, control and laboratory use

Index

D

- Diagnostic messages 27
- Display icons 15

E

- Error messages 27

I

- Icons
 - Display 15
 - Editing mode 15

O

- Operational safety 4

R

- Relay 20

S

- Staff
 - Requirements 4

W

- Workplace safety 4

www.addresses.endress.com
