



Level



Pressure



Flow



Temperature



Liquid
Analysis



Registration



Systems
Components



Services



Solutions

Technical Information

Deltabar M PMD55

Differential pressure measurement

Differential pressure transmitter with metal sensor

Communication via HART, PROFIBUS PA or FOUNDATION

Fieldbus

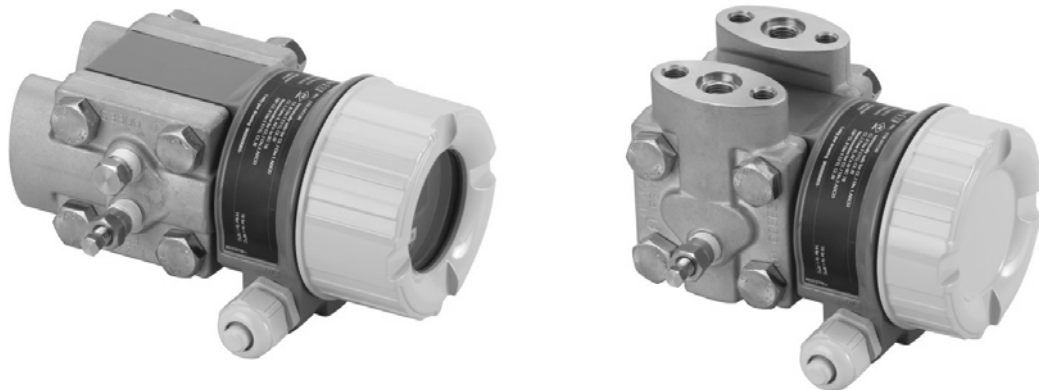

Application

The Deltabar M differential pressure transmitter is used for the following measuring tasks:

- Flow measurement (volume or mass flow) in conjunction with primary elements in gases, vapours and liquids
- Level, volume or mass measurement in liquids
- Differential pressure monitoring, e.g. of filters and pumps

Your benefits

- Reference accuracy: 0,1%
as PLATINUM version: up to 0,075%
- Turn down up to 100:1
- Compact transmitter design
- Quick commissioning via DIP switches
- Easy and safe menu-guided operation
 - on-site via display module
 - via 4 to 20 mA with HART
 - via PROFIBUS PA
 - via FOUNDATION Fieldbus
- Continuous modularity for differential pressure, hydrostatic and pressure (Deltabar M, Deltapilot M Cerabar M), e.g.
 - replaceable display
 - universal electronics
- International usage thanks to a wide range of approvals

Table of contents

Function and system design	3	Storage temperature range	25
Measuring principle	3	Degree of protection	25
Level measurement (level, volume and mass)	3	Climate class	25
Flow measurement	4	Vibration resistance	25
Communication protocol	6	Electromagnetic compatibility	25
		Overvoltage protection (optional)	25
Input	7	Operating conditions (Process)	26
Measured variable	7	Process temperature limits	
Measuring range	7	(temperature at transmitter)	26
Explanation of terms	8	Process temperature range, Seals	26
		Pressure specifications	26
Output	9	Mechanical construction	27
Output signal	9	Process connection	27
Signal range – 4 to 20 mA HART	9	Dimensions V1 version; Impulse pipe vertical; alignment 90° ..	28
Signal on alarm	9	Dimensions H1 version; Impulse pipe horizontal;	
Load – 4 to 20 mA	9	alignment 180°	29
Resolution	9	Dimensions H2 version; Impulse pipe horizontal; alignment 90° .	30
Dead time, Time constant	10	Weight	30
Dynamic behavior: current output	10	Material (not wetted)	31
Dynamic behavior: HART	10	Material (wetted)	32
Dynamic behavior: PROFIBUS PA	10	Human interface	33
Dynamic behavior: FOUNDATION Fieldbus	11	Local operation	33
Damping	11	Remote operation	36
Data of the FOUNDATION Fieldbus interface	12	Hardware and software for onsite and remote operation	37
Power supply	14	Certificates and approvals	38
Electrical connection	14	CE mark	38
Supply voltage	17	Ex approvals	38
Start-up current HART	17	Marine certificate (in preparation)	38
Current consumption	17	CRN approval	38
Cable entry	17	Pressure Equipment Directive (PED)	38
Cable specification	17	Standards and guidelines	38
Residual ripple	17	Ordering information	39
Influence of power supply	17	PMD55	39
Performance characteristics	18	Additional documentation	42
Reference operating conditions	18	Technical Information	42
Reference accuracy	18	Operating Instructions	42
Thermal stability	18	Brief operating instruction	42
Influence of the static pressure	19	Safety Instructions	42
Total Performance	19	Installation/Control Drawings	43
Long-term stability	19	Configuration data sheet	44
Total Error	19	Pressure	44
Influence of the installation position	20	Level	45
Vibration effects	20	Flow	46
Warm-up period	20		
Operating conditions (Installation)	21		
General installation instructions	21		
Measuring arrangement	21		
Wall and pipe-mounting (optional)	22		
Oxygen applications	24		
PWIS cleaning	24		
Ultra pure gas applications	24		
Operating conditions (Environment)	25		
Ambient temperature range	25		

Function and system design

Measuring principle

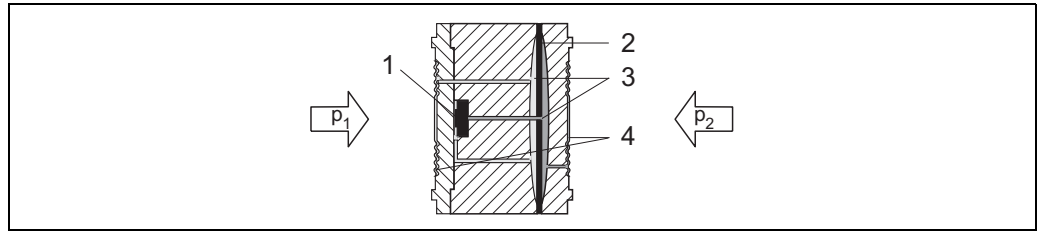

P01-PMD55xxx-03-xx-xx-xx-001

Measuring cell of the Deltabar M

- 1 Sensing element
- 2 Overload diaphragm/Middle diaphragm
- 3 Filling oil
- 4 Process isolating diaphragm

The separating diaphragms (4) are deflected on both sides by the acting pressures p_1 and p_2 . A filling oil (3) transfers the pressure to a resistance circuit bridge (semi-conductor technology). The differential-pressure-dependent change of the bridge output voltage is measured and further processed.

Level measurement (level, volume and mass)

Design and operation mode

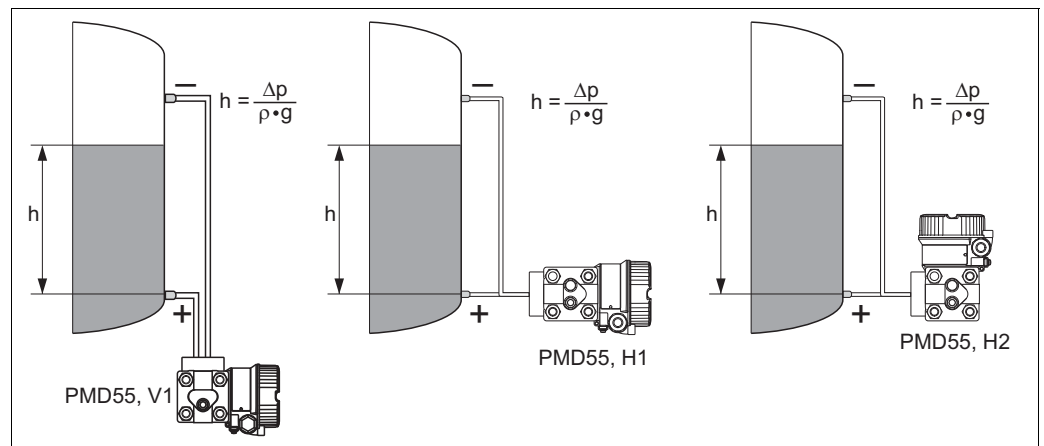

P01-PMD55xxx-15-xx-xx-xx-002

Level measurement with Deltabar M;
 left: V1 version; vertical impulse lines; 90° alignment
 middle: H1 version; horizontal impulse lines; 180° alignment
 right: H2 version; horizontal impulse lines; 90° alignment

- h Height (level)
- Δp Differential pressure
- ρ Density of the medium
- g Gravitation constant

Your benefits

- Volume and mass measurements in any tank shapes by means of a freely programmable characteristic curve
- Choice of diverse level units
- Has a wide range of uses, e.g.
 - for level measurement in tanks with superimposed pressure
 - in the event of foam formation
 - in tanks with agitators or screen fittings
 - in the event of liquid gases
 - for standard level measurement

Flow measurement

Design and operation mode

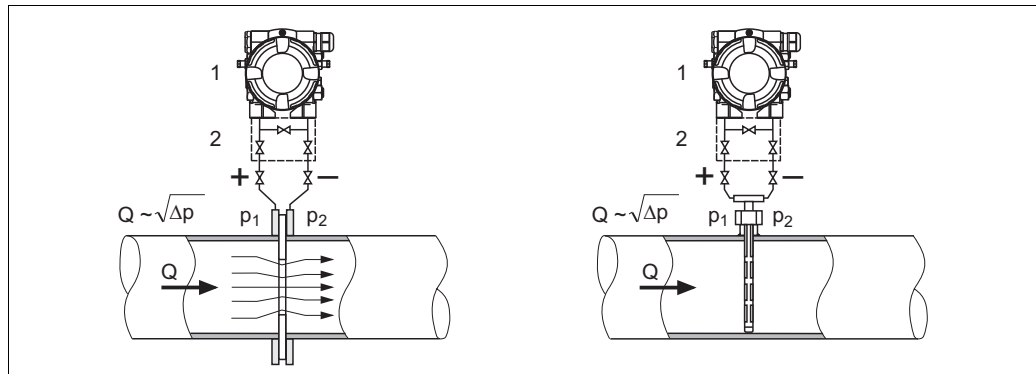

Flow measurement with Deltabar M PMD55 and primary element, left: Orifice plate and right: Pitot tube

- 1 Deltabar M PMD55
 2 3-valve manifold
 Q Flow
 Δp Differential pressure, $\Delta p = p_1 - p_2$

Your benefits

- Choice between five flow modes of operation:
 - Volume flow
 - Norm volume flow (European norm conditions)
 - Standard volume flow (American standard conditions)
 - Mass flow
 - %
- Choice of diverse flow units with automatic unit conversion.
- Low flow cut off: when activated, this function suppresses small flows which can lead to large fluctuations in the measured value.
- Contains two totalizers as standard. One totalizer can be reset to zero.
- The totalizing unit can be individually set for each totalizer. This allows independent daily and annual quantity totalizing.

Note!

For more information about the Deltatop flow measurement system, see

- TI00422P: Deltatop Differential Pressure Flow Measurement with Orifices
- TI00425P: Deltatop Differential Pressure Flow Measurement with Pitot Tubes

Typical arrangements for flow measurements

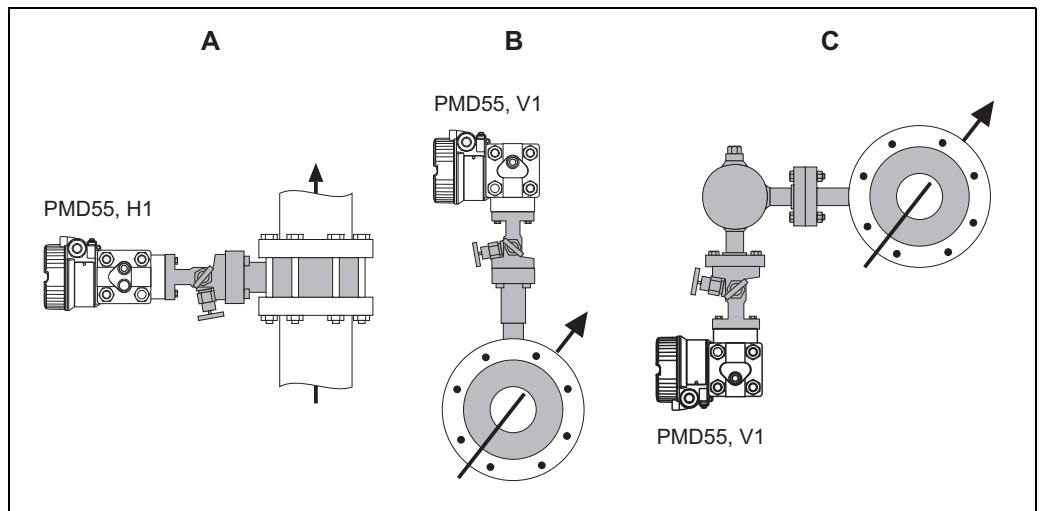

P01-PMD55xxx-11-xx-xx-xx-011

- A: liquid in vertical pipe; H1 version; horizontal impulse line; alignment 180°*
- B: gas in horizontal pipe; V1 version; vertical impulse line; alignment 90°*
- C: steam in horizontal pipe; V1 version; vertical impulse line; alignment 90°*

Mounting example

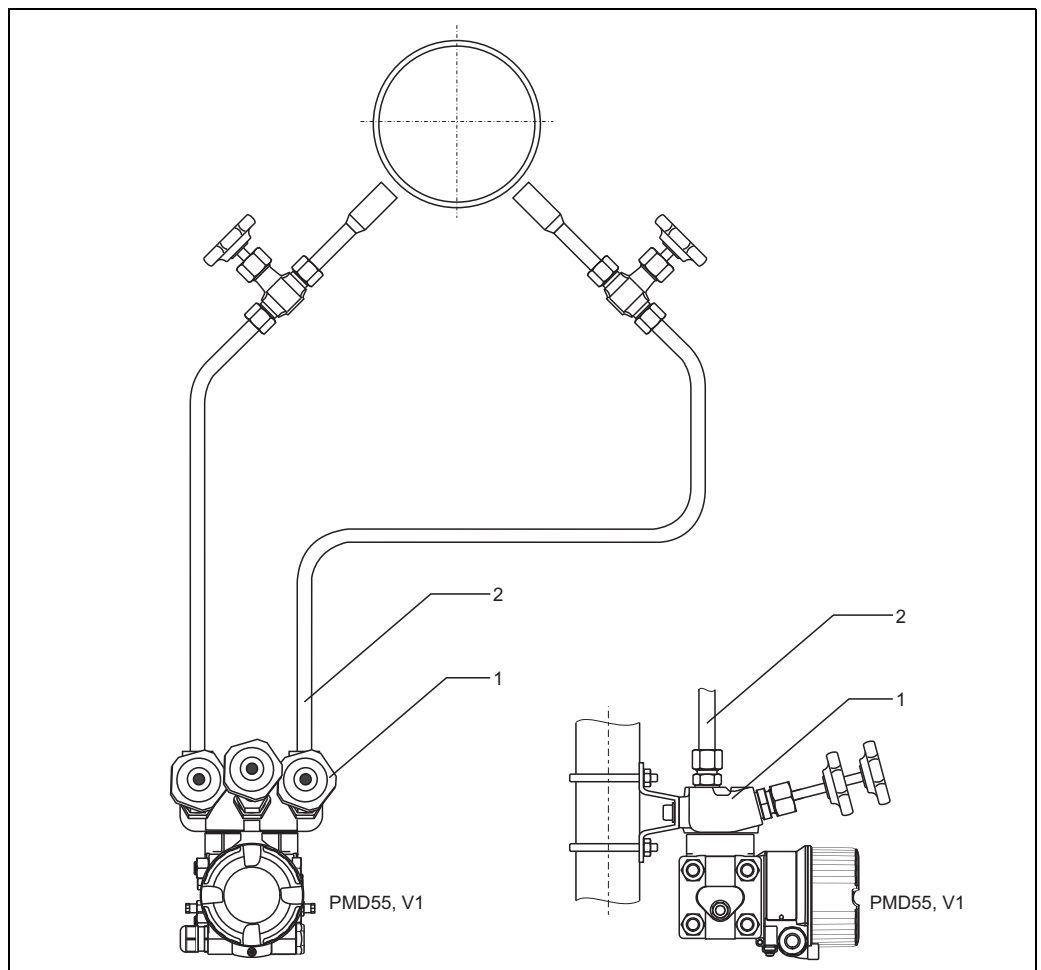

P01-PMD55xxx-11-xx-xx-xx-014

- 1: Valve manifold*
- 2: Impulse line*

Communication protocol

- 4 to 20 mA with HART communication protocol
- PROFIBUS PA
 - The Endress+Hauser devices meet the requirements of the FISCO model.
 - Due to the low current consumption of $11 \text{ mA} \pm 1 \text{ mA}$, the following number of devices can be operated on one bus segment if installing as per FISCO:
 - up to 8 Deltabar M for Ex ia, CSA IS and FM IS applications
 - up to 31 Deltabar M for all other applications, e.g. in non-hazardous areas, Ex nA, etc.

Further information on PROFIBUS PA can be found in Operating Instructions BA00034S "PROFIBUS DP/PA: Guidelines for planning and commissioning" and in the PNO Guideline.
- FOUNDATION Fieldbus
 - The Endress+Hauser devices meet the requirements of the FISCO model.
 - Due to the low current consumption of $16 \text{ mA} \pm 1 \text{ mA}$, the following number of devices can be operated on one bus segment if installing as per FISCO:
 - up to 6 Deltabar M for Ex ia, CSA IS and FM IS applications
 - up to 22 Deltabar M for all other applications, e.g. in non-hazardous areas, Ex nA, etc.

Further information on FOUNDATION Fieldbus, such as requirements for bus system components can be found in Operating Instructions BA00013S "FOUNDATION Fieldbus Overview".

Input

Measured variable Differential pressure, from which flow (volume or mass current) and level (level, volume or mass) are derived.

Measuring range

Nominal value [mbar (psi)]	Measurement limit		Smallest span (factory calibration) ¹ [mbar (psi)]	MWP ² [bar (psi)]	OPL ³		Min. operating pressure ⁴ [mbar _{abs} (psi _{abs})]	Version in the Order Code ⁵ Feature 070
	lower (LRL) [mbar (psi)]	upper (URL) [mbar (psi)]			on one side [bar (psi)]	on both sides [bar (psi)]		
10 (0.15)	-10 (-0.15)	+10 (+0.15)	0.5 (0.0075)	1 (15) ⁶	1 (15) ⁶	1.5 (22.5) ⁶	0.1 (0.0015) ⁶	7B
30 (0.45)	-30 (-0.45)	+30 (+0.45)	1.5 (0.0225)					7C
100 (1.5)	-100 (-1.5)	+100 (+1.5)	5 (0.075)	70 (1050) ⁷ 160 (2400) ⁸	70 (1050) ⁷ 160 (2400) ⁸	105 (1575) ⁷ 240 (3600) ⁸	0.1 (0.0015) ⁷ 0.1 (0.0015) ⁸	7D
500 (7.5)	-500 (-7.5)	+500 (+7.5)	25 (0.375)					7F
1000 (15)	-1000 (-15)	+1000 (+15)	50 (0.75)					7G
3000 (45)	-3000 (-45)	+3000 (+45)	150 (2.25)					7H
16000 (240)	-16000 (-240)	+16000 (+240)	800 (12)					7L
40000 (600)	-40000 (-600)	+40000 (+600)	2000 (30)					7M

- 1) Recommended Turn down: Max 100:1.
Factory calibration Turn down: Max 20:1, higher on request.
- 2) The MWP (maximum working pressure; MWP = PN) for the measuring device depends on the weakest element of the components selected with regard to pressure, i.e. the process connection has to be taken into consideration in addition to the measuring cell. Also observe the pressure-temperature dependency. For the appropriate standards and further information → 26.
- 3) OPL: over pressure limit; depends on the lowest-rated element, with regard to pressure, of the selected components (→ 26).
- 4) The minimum operating pressure indicated in the table applies to silicone oil under reference operating conditions.
Minimum operating pressure at 85°C (185°F) for silicone oil: 10 mbar (0,15 psi) (abs)
- 5) See also chapter "Ordering information"
- 6) Version "2" in the Order Code - Feature 60
- 7) Version "6" in the Order Code - Feature 60
- 8) Version "7" in the Order Code - Feature 60

Explanation of terms

Explanation of the terms: Turn down (TD), set span and zero based span

Case 1:

- Lower range value \leq Upper range value

Example:

- Lower range value (LRV) = 0 mbar
- Upper range value (URV) = 100 mbar (1.5 psi)
- Nominal value (URL) = 500 mbar (7.5 psi)

Turn down:

- $TD = URL / |URV| = 5:1$

set span:

- $URV - LRV = 100 \text{ mbar (1.5 psi)}$
This span is based on the zero point.

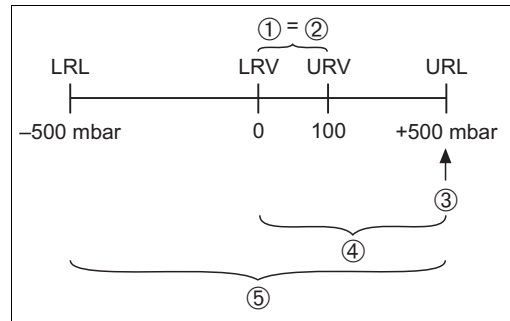

P01-xxxxxxx-05-xx-xx-xx-001

Example: 500 mbar (7.5 psi) sensor

Case 2:

- Lower range value \geq Upper range value

Example:

- Lower range value (LRV) = -300 mbar (4.5 psi)
- Upper range value (URV) = 0 bar
- Nominal value (URL) = 500 mbar (7.5 psi)

Turn down:

- $TD = URL / |(LRV)| = 1,67:1$

set span:

- $URV - LRV = 300 \text{ mbar (4.5 psi)}$
This span is based on the zero point.

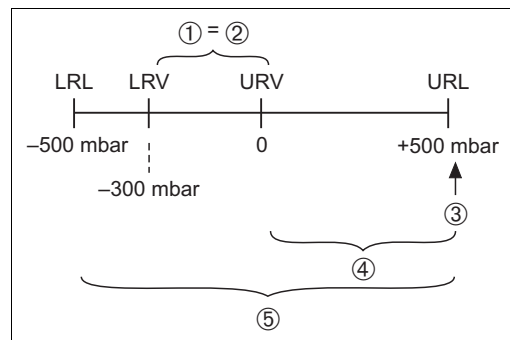

P01-xMD7xxxx-05-xx-xx-xx-007

Example: 500 mbar (7.5 psi) sensor

- 1 Set span
- 2 Zero based span
- 3 Nominal value \cong Upper range limit (URL)
- 4 Nominal measuring range
- 5 Sensor measuring range
- LRL Lower range limit
- URL Upper range limit
- LRV Lower range value
- URV Upper range value

Output

Output signal

- 4 to 20 mA with superimposed digital communication protocol HART 6.0, 2-wire
- Digital communication signal PROFIBUS PA (Profile 3.02)
- Digital communication signal FOUNDATION Fieldbus

**Signal range –
4 to 20 mA HART**

3.8 mA to 20.5 mA

Signal on alarm

As per NAMUR NE 43

- 4 to 20 mA HART
 - Options:
 - Max. alarm*: can be set from 21...23 mA (factory setting: 22 mA)
 - Keep measured value: last measured value is kept
 - Min. alarm: 3.6 mA
- PROFIBUS PA: can be set in the Analog Input block,
 - Options: Last Valid Out Value (factory setting), Fail-safe Value, Status Bad
- FOUNDATION Fieldbus: can be set in the Analog Input block,
 - Options: Last Good Value, Fail-safe Value (factory setting), Wrong Value

Load – 4 to 20 mA

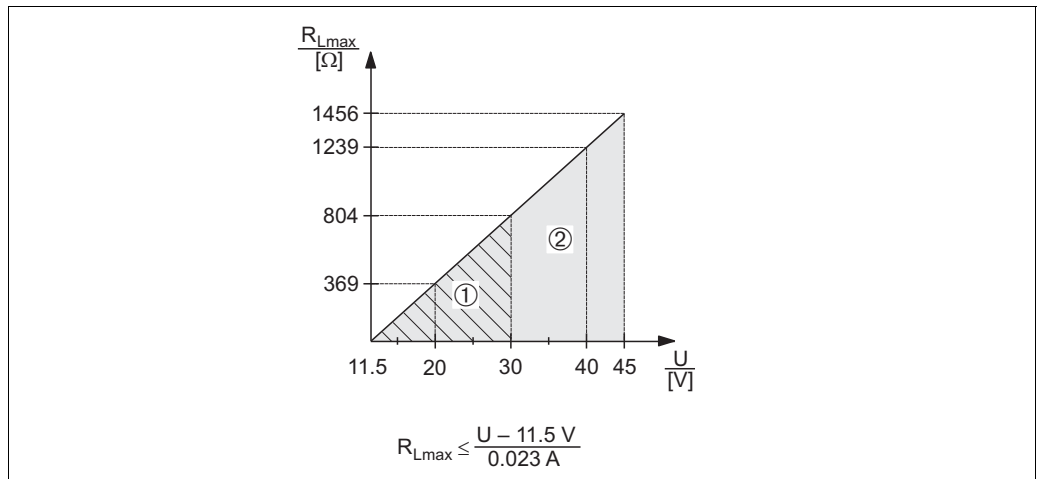

Load diagram

1 Supply voltage 11.5 ... 30 V DC for intrinsically safe instrument versions

2 Supply voltage 11.5 ... 45 V DC (versions with plug-in connector 35 V DC) for other types of protection and for uncertified instrument versions

R_{Lmax} Maximum load resistance

U Supply voltage

Note!

When operating via a handheld terminal or via PC with an operating program, a minimum communication resistance of 250 Ω must exist within the loop.

Resolution

- Current output: 1 μA
- Display: can be set (factory setting: presentation of the maximum accuracy of the transmitter)

Dead time, Time constant

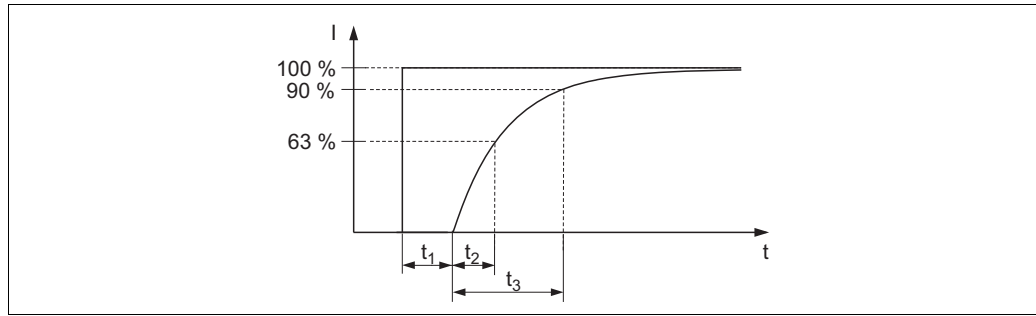

Presentation of the dead time and the time constant

Dynamic behavior: current output

	Dead time (t_1) [ms]	Time constant T63 ($= t_2$) [ms]	Time constant T90 ($= t_3$) [ms]
max.	60	90	210

Dynamic behavior: HART

	Dead time (t_1) [ms]	Dead time (t_1) [ms] + Time constant T63 ($= t_2$) [ms]	Dead time (t_1) [ms] + Time constant T90 ($= t_3$) [ms]
min.	220	310	370
max.	1020	1110	1170

Reading cycle

- Acyclic: max. 3/s, typical 1/s (depends on command # and number of preambles)
- Cyclic (Burst): max. 3/s, typical 2/s

The Deltabar M commands the BURST MODE function for cyclic value transmission via the HART communication protocol.

Cycle time (Update time)

Cyclic (Burst): min. 300 ms

Response time

- Acyclic: min. 330 ms, typical 590 ms (depends on command # and number of preambles)
- Cyclic (Burst): min. 160 ms, typical 350 ms (depends on command # and number of preambles)

Dynamic behavior: PROFIBUS PA

	Dead time (t_1) [ms]	Dead time (t_1) [ms] + Time constant T63 ($= t_2$) [ms]	Dead time (t_1) [ms] + Time constant T90 ($= t_3$) [ms]
min.	95	185	245
max.	1195	1285	1345

Reading cycle

- Cyclic: max. 30/s (dependent on the number and type of function blocks used in a closed-control loop)
- Acyclic: typical 25/s

Cycle time (update time)

min. 100 ms

The cycle time in a bus segment in cyclic data communication depends on the number of devices, on the segment coupler used and on the internal PLC cycle time.

Response time

- Cyclic: approx. 8 to 13 ms (depends on Min. Slave Interval)
- Acyclic: approx. 23 to 35 ms (depends on Min. Slave Interval)

**Dynamic behavior:
FOUNDATION Fieldbus**

	Dead time (t_1) [ms]	Dead time (t_1) [ms] + Time constant T63 (= t_2) [ms]	Dead time (t_1) [ms] + Time constant T90 (= t_3) [ms]
min.	105	195	255
max.	1105	1195	1255

Reading cycle

- Cyclic: max. 10/s (dependent on the number and type of function blocks used in a closed-control loop)
- Acyclic: typical 5/s

Cycle time (update time)

Cyclic: min. 100 ms

Response time

- Cyclic: max. 20 ms (for standard bus parameter settings)
- Acyclic: typical 70 ms (for standard bus parameter settings)

Damping

A damping affects all outputs (output signal, display).

- Via on-site display, handheld terminal or PC with operating program, continuous from 0...999 s
- Via DIP-switch on the electronic insert, switch position "on" (= set value) and "off" (= damping switched off)
- Factory setting: 2 s

**Data of the FOUNDATION
Fieldbus interface**
Basic data

Device Type	0x1021
Device Revision	01 (hex)
DD Revision	0x01021
CFF Revision	0x000102
ITK Version	5.2.0
ITK Certification Driver No.	IT067600
Link-Master (LAS) capable	Yes
Link Master / Basic Device selectable	Yes; Factory setting: Basic Device
Number of VCRs	44
Number of Link Objects in VFD	50
Number of FB-Schedule Objects	40

Virtual communication references (VCRs)

Permanent Entries	44
Client VCRs	0
Server VCRs	5
Source VCRs	8
Sink VCRs	0
Subscriber VCRs	12
Publisher VCRs	19

Link settings

Slot time	4
Min. inter PDU delay	12
Max. response delay	40

Transducer Blocks

Block	Content	Output values
TRD1 Block	Contains all parameters related to the measurement	<ul style="list-style-type: none"> ■ Pressure or level (channel 1) ■ Process temperature (channel 2) ■ Measured pressure value (channel 3) ■ Max. pressure (channel 4) ■ Level before linearization (channel 5)
Dp Flow Block	enthält Durchfluss und Summenzähler Parameter	<ul style="list-style-type: none"> ■ Totalizer 1 (channel 6) ■ Totalizer 2 (channel 7)
Diagnostic Block	Contains diagnostic information	Error code via DI channels (channel 10 to 15)
Display Block	Contains parameters to configure the onsite display	No output values

Function blocks

Block	Content	Number of blocks	Execution time	Functionality
Resource Block	The Resource Block contains all the data that uniquely identify the device. It is an electronic version of a nameplate of the device.	1		enhanced
Analog Input Block 1 Analog Input Block 2	The AI Block receives the measuring data from the Sensor Block, (selectable via a channel number) and makes the data available to other function blocks at its output. Enhancement: digital outputs for process alarms, fail safe mode.	2	25 ms	enhanced
Digital Input Block	This block contains the discrete data of the Diagnose Block (selectable via a channel number 10 to 15) and provides them for other blocks at the output.	1	40 ms	standard
Digital Output Block	This block converts the discrete input and thus initiates an action (selectable via a channel number) in the DP Flow Block or in the im TRD1 Block. Channel 20 resets the counter for max. pressure transgressions value and Channel 21 resets the Totalizer.	1	20 ms	standard
PID Block	The PID Block serves as a proportional-integral-derivative controller and is used almost universally for closed-loop-control in the field including cascade and feedforward. Input IN can be indicated on the display. The selection is performed in the Display Block (DISPLAY_MAIN_LINE_CONTENT).	1	40 ms	standard
Arithmetic Block	This block is designed to permit simple use of popular measurement math functions. The user does not have to know how to write equations. The math algorithm is selected by name, chosen by the user for the function to be performed.	1	35 ms	standard
Input Selector Block	The Input Selector Block facilitates the selection of up to four inputs and generates an output based on the configured action. This block normally receives its inputs from AI Blocks. The block performs maximum, minimum, average and 'first good' signal selection. Inputs IN1 to IN4 can be indicated on the display. The selection is performed in the Display Block (DISPLAY_MAIN_LINE_1_CONTENT).	1	30 ms	standard
Signal Characterizer Block	The Signal Characterizer Block has two sections, each with an output that is a non-linear function of the respective input. The non-linear function is generated by a single look-up table with 21 arbitrary x-y pairs.	1	40 ms	standard
Integrator Block	The Integrator Block integrates a variable as a function of the time or accumulates the counts from a Pulse Input Block. The block may be used as a totalizer that counts up until reset or as a batch totalizer that has a setpoint, where the integrated or accumulated value is compared to pre-trip and trip settings, generating a binary signal when the setpoint is reached.	1	35 ms	standard

Additional function block information:

Instantiate Function Block	YES
Number of instantiate blocks	14

Power supply

Electrical connection

Note!

- When using the measuring device in hazardous areas, installation must comply with the corresponding national standards and regulations and the Safety Instructions or Installation or Control Drawings → 42, section "Safety Instructions" and "Installation/Control Drawings".
- According to IEC/EN61010 a suitable disconnector has to be installed for the device.
- Devices with integrated overvoltage protection must be earthed.
- Protective circuits against reverse polarity, HF influences and overvoltage peaks are installed.
- The digital communication signal is transmitted to the bus via a 2-wire connection. The bus also provides the power supply.

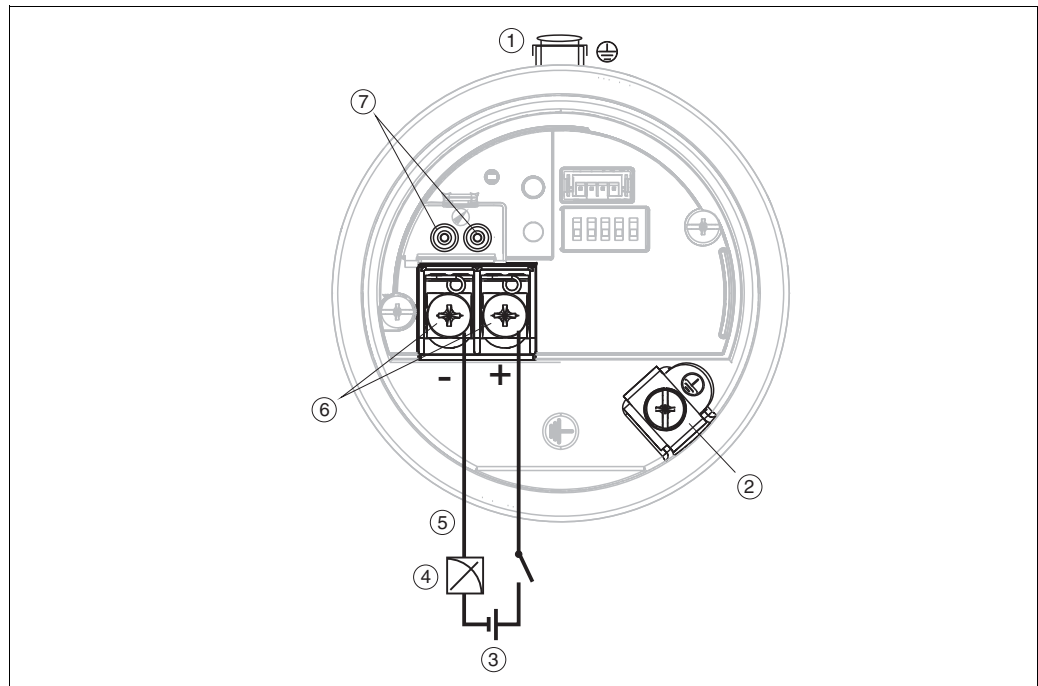

Electrical connection

- 1 External grounding terminal
- 2 Internal grounding terminal
- 3 Supply voltage → 17
- 4 4...20 mA for HART devices
- 5 For HART and FOUNDATION Fieldbus devices: With a handheld terminal, all the parameters can be configured anywhere along the bus line via menu operation.
- 6 Terminals
- 7 For HART devices: test terminals, see section "Taking a 4 to 20 mA test signal"

4...20 mA HART

Taking a 4 to 20 mA test signal

A 4 to 20 mA test signal may be measured via the test terminals without interrupting the measurement.

PROFIBUS PA

For further information on the network structure and grounding, and for further bus system components such as bus cables, see the relevant documentation, e.g. Operating Instructions BA00034S "PROFIBUS DP/PA: Guidelines for planning and commissioning" and the PNO Guideline.

Cable specifications:

Use a twisted, shielded two-wire cable, preferably cable type A

Note!

For further information on the cable specifications, see Operating Instructions BA00034S "PROFIBUS DP/PA: Guidelines for planning and commissioning", the PNO Guideline 2.092 PROFIBUS PA User and Installation Guideline" and IEC 61158-2 (MBP).

FOUNDATION Fieldbus

The digital communication signal is transmitted to the bus via a 2-wire connection. The bus also provides the power supply. For further information on the network structure and grounding and for further bus system components such as bus cables, see the relevant documentation, e.g. Operating Instructions BA00013S "FOUNDATION Fieldbus Overview" and the FOUNDATION Fieldbus Guideline.

Cable specifications:

Use a twisted, shielded two-wire cable, preferably cable type A

Note!

For further information on the cable specifications, see Operating Instructions BA00013S "FOUNDATION Fieldbus Overview", FOUNDATION Fieldbus Guideline and IEC 61158-2 (MBP).

Devices with valve connector

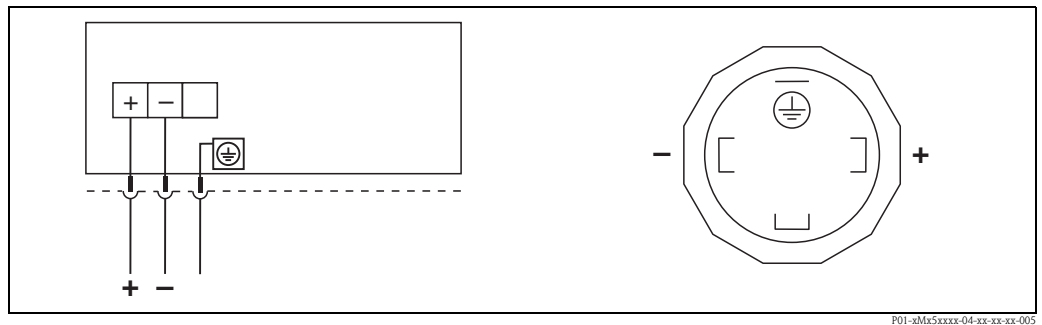

P01-xMx5xxxx-04-xx-xx-xx-005

Left: electrical connection for devices with a valve connector
 Right: view of the connector at the device

Material: PA 6.6

Devices with Harting plug Han7D

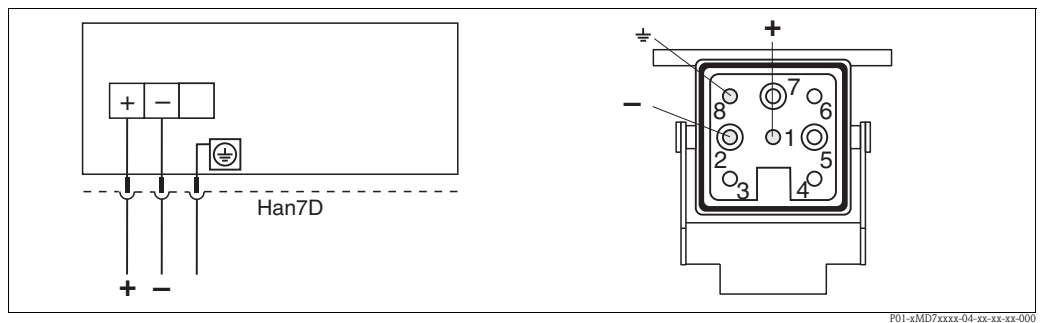

P01-xMD7xxxx-04-xx-xx-xx-000

Left: electrical connection for devices with Harting plug Han7D
 Right: view of the plug connector at the device

Material: CuZn

Devices with M12 plug

PIN assignment for M12 connector

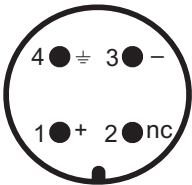
	PIN	Meaning
	1	Signal +
	2	Not assigned
	3	Signal -
	4	Earth

Endress+Hauser offers the following accessories for devices with an M12 plug:

Plug-in jack M 12x1, straight

- Material: body PA; coupling nut CuZn, nickel-plated
- Degree of protection (fully locked): IP67
- Order number: 52006263

Plug-in jack M 12x1, elbowed

- Material: body PBT/PA; coupling nut GD-Zn, nickel-plated
- Degree of protection (fully locked): IP67
- Order number: 71091284

Cable 4x0.34 mm² (20 AWG) with M12 socket, elbowed, screw plug, length 5 m (16 ft)

- Material: body PUR; coupling nut CuSn/Ni; cable PVC
- Degree of protection (fully locked): IP67
- Order number: 52010285

Devices with 7/8" plug

PIN assignment for 7/8" connector

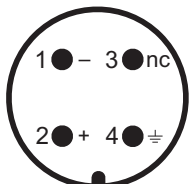
	PIN	Meaning
	1	Signal -
	2	Signal +
	3	Not assigned
	4	Earth

External thread: 7/8 - 16 UNC

- Material: housing / body CuZn, nickel-plated
- Protection: IP68
- Order number: 52010285

Supply voltage

Note!

- When using the measuring device in hazardous areas, installation must comply with the corresponding national standards and regulations and the Safety Instructions or Installation or Control Drawings.
- All explosion protection data are given in separate documentation which is available upon request. The Ex documentation is supplied as standard with all devices approved for use in explosion hazardous areas
→ 42, sections "Safety Instructions" and "Installation/Control drawing".

4 to 20 mA HART

Type of protection	Supply voltage
<ul style="list-style-type: none"> ■ Intrinsically safe 	11.5 ... 30 V DC
<ul style="list-style-type: none"> ■ Other types of protection ■ Devices without certificate 	11.5 ... 45 V DC (Versions with plug-in connection 35 V DC)

PROFIBUS PA

- Version for non-hazardous areas: 9 to 32 V DC

FOUNDATION Fieldbus

- Version for non-hazardous areas: 9 to 32 V DC

Start-up current HART

12 mA or 22 mA (selectable)

Current consumption

- PROFIBUS PA: 11 mA ± 1 mA, switch-on current corresponds to IEC 61158-2, Clause 21
- FOUNDATION Fieldbus: 16 mA ± 1 mA, switch-on current corresponds to IEC 61158-2, Clause 21

Cable entry

→ See product structure, → 39, feature 050 "Electrical connection".

Cable specification

- Endress+Hauser recommends using shielded, twisted-pair two-wire cables.
- Terminals for wire cross-sections 0.5...2.5 mm² (20...14 AWG)
- Cable external diameter: 5...9 mm (0.2...0.35 in)

Residual ripple

Without influence on 4 to 20 mA signal up to ± 5 % residual ripple within the permitted voltage range [according to HART hardware specification HCF_SPEC-54 (DIN IEC 60381-1)]

Influence of power supply

≤ 0.001% of URL/V

Performance characteristics

Reference operating conditions

- As per IEC 60770 and IEC 61298-1, Sections 5 to 7
- Ambient temperature T_U = constant, in the range of: +21...+33°C (+70...91 °F)
- Humidity φ = constant, in the range of: 5...80 % r.H
- Ambient pressure p_U = constant, in the range of: 860...1060 mbar (12.47...15.37 psi)
- Position of the measuring cell: constant, in the range of: $\pm 1^\circ$ horizontally and $\pm 1^\circ$ vertically
- P1 = high pressure side
- Input of "Lo Trim Sensor" and "Hi Trim Sensor" for lower range value and upper range value
- Measuring span URV - LRV
- Membrane material 316L
- Filling oil: silicone oil
- Side flanges material: AISI 316L
- Supply voltage: 24 V DC \pm 3 V DC
- Load with HART: 250 Ω

Reference accuracy

The reference accuracy comprises the non-linearity according to limit point setting, hysteresis and non-reproducibility as per IEC 60770.

The following applies for the root-extracting characteristic curve:

The accuracy data of the Deltabar M is taken into the accuracy calculation of the flow rate with a factor of 0.5.

Measuring cell	% of the set span	
	Standard	Platinum
10 mbar (0.15 psi) 30 mbar (0.45 psi)	<ul style="list-style-type: none"> ■ TD 1:1 = ± 0.2 ■ TD > 1:1 = $\pm(0.2 \times \text{TD})$ 	—
100 mbar (1.5 psi)	<ul style="list-style-type: none"> ■ TD 1:1 to TD 4:1 = ± 0.1 ■ TD > 4:1 = $\pm(0.012 \times \text{TD} + 0.052)$ 	<ul style="list-style-type: none"> ■ TD 1:1 to TD 4:1 = ± 0.075 ■ TD > 4:1 = $\pm(0.012 \times \text{TD} + 0.027)$
500 mbar (7.5 psi) 1 bar (15 psi) 3 bar (45 psi) 16 bar (240 psi) 40 bar (600 psi)	<ul style="list-style-type: none"> ■ TD 1:1 to TD 10:1 = ± 0.1 ■ TD > 10:1 = $\pm(0.0015 \times \text{TD} + 0.085)$ 	<ul style="list-style-type: none"> ■ TD 1:1 to TD 10:1 = ± 0.075 ■ TD > 10:1 = $\pm(0.0015 \times \text{TD} + 0.060)$

TD: Turn Down, → 8

Thermal stability

Measuring cell	-10 to +60°C (+14 to +140°F)	-40 to -10°C, +60 to +85°C (-40 to +14°F, +140 to +185°F)
	% of the set span	
10 mbar (0.15 psi) 30 mbar (0.45 psi)	$\pm(0.31 \times \text{TD} + 0.5)$	$\pm(0.45 \times \text{TD} + 0.45)$
100 mbar (1.5 psi)	$\pm(0.18 \times \text{TD} + 0.31)$	$\pm(0.3 \times \text{TD} + 0.36)$
500 mbar (7.5 psi) 1 bar (15 psi) 3 bar (45 psi)	$\pm(0.08 \times \text{TD} + 0.32)$	$\pm(0.12 \times \text{TD} + 0.36)$
16 bar (240 psi)	$\pm(0.10 \times \text{TD} + 0.34)$	$\pm(0.15 \times \text{TD} + 0.39)$
40 bar (600 psi)	$\pm(0.08 \times \text{TD} + 0.32)$	$\pm(0.37 \times \text{TD} + 0.34)$

TD: Turn Down, → 8

Influence of the static pressure

Measuring cell	Influence on zero point	Influence on span
10 mbar (0.15 psi)	±0.2 % v. URL / 1 bar	±0.2 % v. URL / 1 bar
30 mbar (0.45 psi)	±0.07 % v. URL / 1 bar	±0.07 % v. URL / 1 bar
100 mbar (1.5 psi)	±0.15 % of URL / 70 bar	±0.14 % of URL / 70 bar
500 mbar (7.5 psi) 1 bar (15 psi) 3 bar (45 psi) 16 bar (240 psi) 40 bar (600 psi)	±0.075 % of URL / 70 bar	±0.14 % of URL / 70 bar

Note!

The influence of the static pressure on the zero point can be calibrated out.

Total Performance

The "Total performance" specification comprises the non-linearity including hysteresis, non-reproducibility, the thermal change of the zero point as well as the influence of the line pressure p_{st} . The line pressure p_{st} is 70 bar (1050 psi) for the 100 mbar, 500 mbar, 1 bar, 3 bar, 16 bar und 40 bar measuring cell.

Measuring cell	% of the set span			
	Standard, TD 1:1		Platinum, TD 1:1	
	-10 to +60°C (14 to 140°F)	-40 to -10°C; +60 to +85°C (-40 to +14°F; 140 to 185°F)	-10 to +60°C (14 to 140°F)	-40 to -10°C; +60 to +85°C (-40 to +14°F; 140 to 185°F)
100 mbar (1.5 psi)	±0.18	±0.23	±0.17	±0.23
500 mbar (7.5 psi) 1 bar (15 psi) 3 bar (45 psi)	±0.13	±0.16	±0.12	±0.15
16 bar (240 psi)	±0.16	±0.24	±0.15	±0.23
40 bar (600 psi)	±0.13	±0.16	±0.12	±0.15

Long-term stability

Measuring cell	% of URL / 1 year	% of URL / 5 years
10 mbar (0.15 psi) 30 mbar (0.45 psi)	in preparation	
100 mbar (1.5 psi)	±0.18	±0.35
500 mbar (7.5 psi) 1 bar (15 psi) 3 bar (45 psi) 16 bar (240 psi) 40 bar (600 psi)	±0.05	±0.13

Total Error

Measuring cell	% of URL / 1 year	% of URL / 5 years
10 mbar (0.15 psi) 30 mbar (0.45 psi)	in preparation	
100 mbar (1.5 psi)	±0.26	±0.39
500 mbar (7.5 psi) 1 bar (15 psi) 3 bar (45 psi)	±0.14	±0.18
16 bar (240 psi)	±0.17	±0.20
40 bar (600 psi)	±0.14	±0.18

Influence of the installation position

The recommended maximum angle to the axis of the diaphragm is 10° and results in a measuring error of ± 0.72 mbar (0.01 psi). The value is doubled for devices with inert oil.

Note!

Position-dependent zero shift can be corrected → 21, section "General installation instructions".

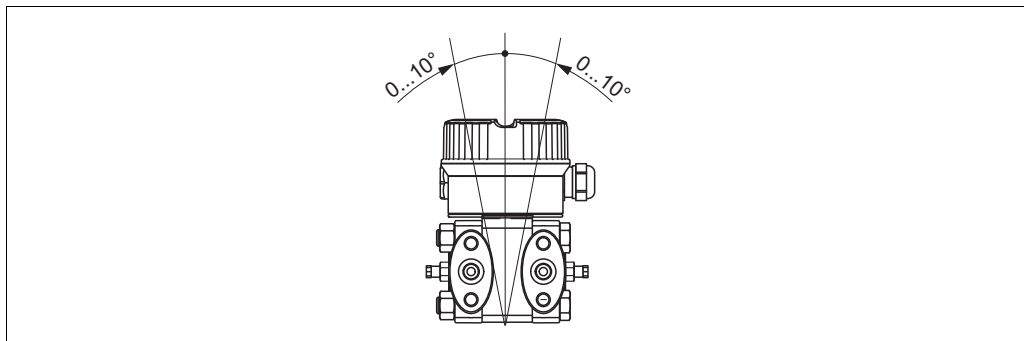

P01-PMD55xxx-17-xx-xx-xx-001

Vibration effects

Test standard	Vibration effects
GL	<p>≤ reference accuracy to 10...18 Hz: ± 4 mm (0.16 in);</p> <p>18...500 Hz: 5 g</p>
IEC 61298-3	<p>≤ reference accuracy to 10...60 Hz: ± 0.35 mm (0.01 in);</p> <p>60...2000 Hz: 5 g</p>

Warm-up period

- 4 to 20 mA HART: ≤ 5 s
- PROFIBUS PA: ≤ 8 s
- FOUNDATION Fieldbus: ≤ 20 s (after a TOTAL-reset ≤ 45 s)

Operating conditions (Installation)

General installation instructions

- The position-dependent zero shift can be corrected directly at the device via operating keys.
- Endress+Hauser offers a mounting bracket for installing the device on pipes or walls →  22, section "Wall and pipe mounting".
- When measuring in media with solid proportions, such as dirty liquids, installing separators and drain valves is useful for capturing and removing sediment.
- Using a three-valve or five-valve manifold allows for easy commissioning, installation and maintenance without interrupting the process.
- General recommendations for the impulse piping can be found in DIN 19210 "Methods for measurement of fluid flow; differential piping for flow measurement devices" or the corresponding national or international standards.
- Install the impulse piping with a continuous gradient of at least 10 %.
- When routing the impulse piping outdoors, ensure that sufficient anti-freeze protection is used, e.g. by using pipe heat tracing.

Measuring arrangement

Flow measurement

- Measuring arrangement for gases: Mount device above the measuring point.
- Measuring arrangement for liquids and vapours: Mount device below tapping point.
- For flow measurement in vapours, mount the condensate traps at the same level as the same the tapping point and at the same distance from Deltabar M.

Level measurement

Measuring arrangement level measurement in open tanks

- Mount device below the lower measuring connection. The low-pressure side is open to atmosphere pressure.

Measuring arrangement level measurement in closed tanks and closed tanks with superimposed vapour

- Mount device below the lower measuring connection. Always connect the low-pressure side above the maximum level.
- In the case of level measurement in closed tanks with superimposed vapour, a condensate trap ensures pressure which remains constant on the low-pressure side.

Pressure measurement

- Measuring arrangement for gases: Mount device above the measuring point.
- Measuring arrangement for liquids and steams: Mount device below tapping point.
- For differential pressure measurement in vapour, mount the condensate traps at the same level as the same the tapping point and at the same distance from Deltabar M.

Wall and pipe-mounting (optional)

Endress+Hauser offers a mounting bracket for installing the device on pipes or walls. A bracket with mounting accessories for pipe mounting is included with the device.

Note!

When using a valve block, the block's dimensions must be taken into account.

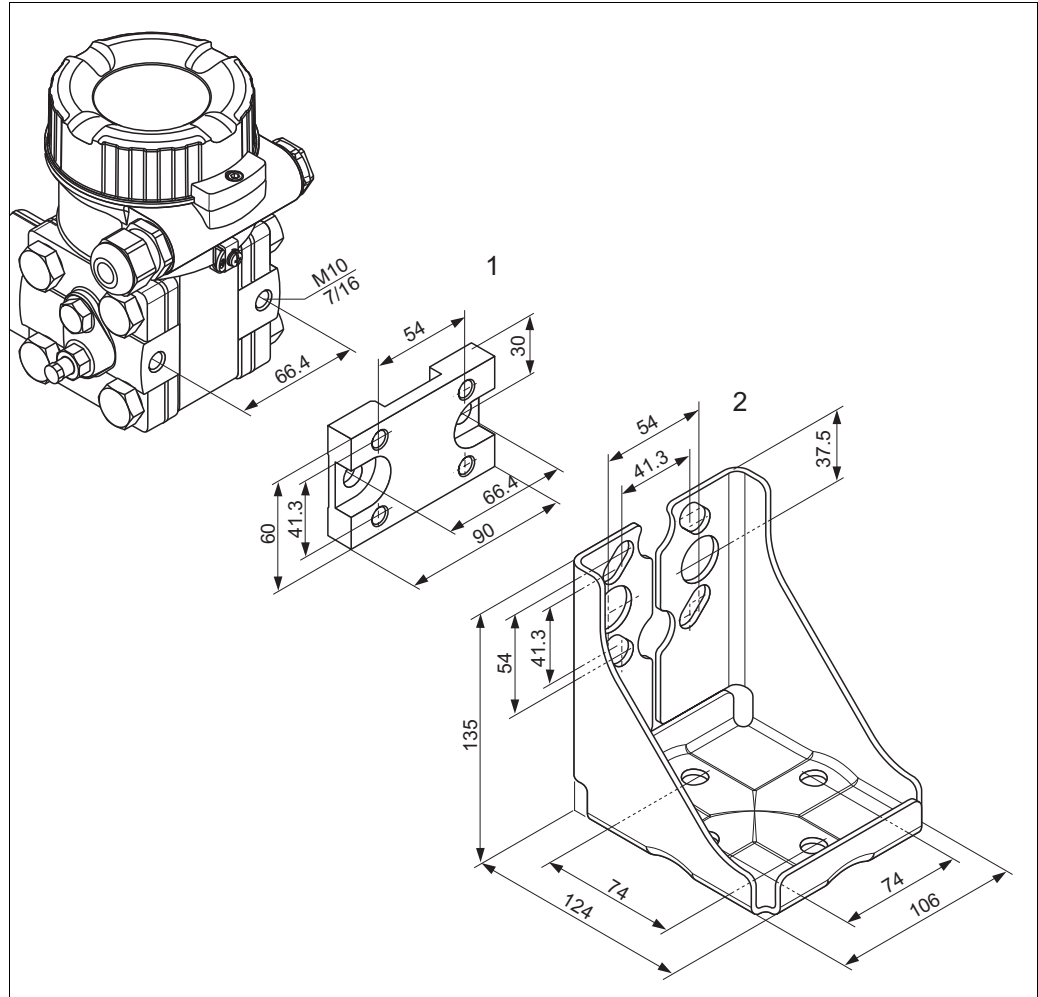

P01-PMD55xxx-06-xx-xx-xx-004

Mounting bracket for wall and pipe mounting

- 1 Adapter plate (+ six screws and six washers)
2 Mounting bracket (+ bracket for pipe mounting and two nuts)

Please note the following when mounting:

- To prevent the mounting screws from scoring, lubricate them with a multi-purpose grease prior to mounting.
- In the case of pipe mounting, the nuts on the bracket must be tightened uniformly with a torque of at least 30 Nm (22.13 lbf ft).

Ordering information:

- See Product structure → 39 ff: Feature 620 "Accessory Enclosed", option PB and PC
- As Accessory:
 - Adapter plate 7/16 - 20 UNF part number: 71098632
 - Adapter plate M10 part number: 71101935
 - Mounting bracket and adapter plate 7/16 - 20 UNF part number: 71098630
 - Mounting bracket and adapter plate M10 part number: 71101934

Typical installation arrangements

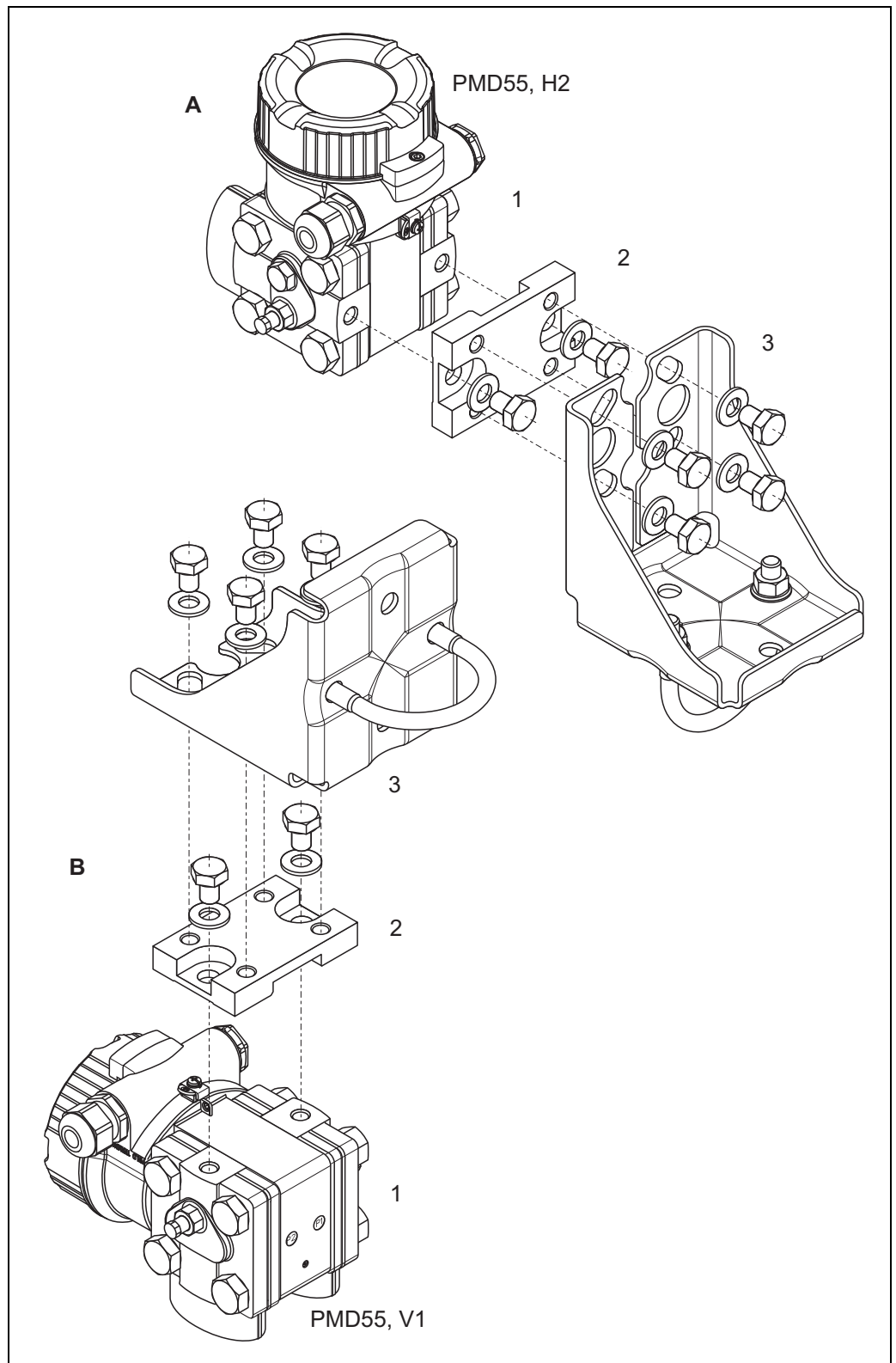

A: Installation for horizontal impulse pipes; H2 version
B: Installation for vertical impulse pipes; V1 version
1: Deltabar M; 2: Adapter; 3: Mounting bracket

P01-PMD55xxx-17-xx-xx-xx-001

Oxygen applications

Oxygen and other gases can react explosively to oils, grease and plastics, such that, among other things, the following precautions must be taken:

- All components of the system, such as measuring devices, must be cleaned in accordance with the BAM (DIN 19247) requirements.
Product structure (→ 39): Feature 570 "Service", option HB "Cleaned for oxygen service"
- Dependent on the materials used, a certain maximum temperature and a maximum pressure for oxygen applications must not be exceeded.

Option 190 "Seal"	P _{max} for Oxygen applications	T _{max} for Oxygen applications
A: FKM Viton	30 bar (450 psi)	-18 to +60°C (0 to 140°F)

PWIS cleaning

Special cleaning of the transmitter to remove paint-wetting substances, for use in paint shops

→ 39 feature 570 "Service", version "HC".

Ultra pure gas applications

Endress+Hauser also offers devices for special applications, such as ultra pure gas, cleaned from oil and grease.

Product structure (→ 39): Feature 570 "Service", option HA "Cleaned from oil + grease".

No special restrictions regarding the process conditions apply to these devices.

Operating conditions (Environment)

Ambient temperature range

- $-40...+85^{\circ}\text{C}$ (-40 to $+185^{\circ}\text{F}$)
- On-site display: -20 to $+70^{\circ}\text{C}$ (-4 to 158°F)
 Enhanced temperature range with limitations concerning display speed and contrast: -40 to $+85^{\circ}\text{C}$ (-40 to $+185^{\circ}\text{F}$)

For devices for use in hazardous areas, see Safety instructions, Installation or Control Drawing → 42, sections "Safety Instruction" and "Installation/Control drawings").

Storage temperature range

- -40 to $+90^{\circ}\text{C}$ (-40 to $+194^{\circ}\text{F}$)
- On-site display: -40 to $+85^{\circ}\text{C}$ (-40 to $+185^{\circ}\text{F}$)

Degree of protection → 39, feature 050 "Electrical connection"

Climate class Class 4K4H (air temperature: $-20...55^{\circ}\text{C}$ ($-4...+131^{\circ}\text{F}$), relative humidity: 4...100%) fulfilled as per DIN EN 60721-3-4 (condensation possible)

Vibration resistance

Device	Test standard	Vibration resistance
PMD55	GL	guaranteed for: 2...18 Hz: ± 4 mm (0.16 in); 18...500 Hz: 5 g in all 3 planes
	IEC 61298-3	guaranteed for: 10...60 Hz: ± 0.35 mm (0.014 in); 60...2000 Hz: 5 g in all 3 planes
PMD55 with mounting bracket	IEC 61298-3	guaranteed for: 10...60 Hz: ± 0.15 mm (0.006 in); 60...500 Hz: 2 g in all 3 planes

Electromagnetic compatibility

- Electromagnetic compatibility as per all the relevant requirements of the EN 61326 series and NAMUR Recommendation EMC (NE21). Details can be found in the Declaration of Conformity (in the Download area of "www.de.endress.com", "search area - Approvals and Certificates", "Manufact. Declaration").
- Maximum deviation: $< 0.5\%$ of span
- Larger deviations possible with 10 mbar (0.15 psi) measuring cell.

Overvoltage protection (optional)

The device can be fitted with overvoltage protection, → 39 ff "Ordering information" feature 610 "Accessory mounted:" version "NA". The overvoltage protection is mounted at the factory on the housing thread (M20x1.5) for the cable gland and is approx. 70 mm (2.76 in) in length (take additional length into account when installing). The device is connected as illustrated in the following graphic. For details refer to TI00103R/09/EN, XA00036R/09/A3 and KA00161R/09/A6.

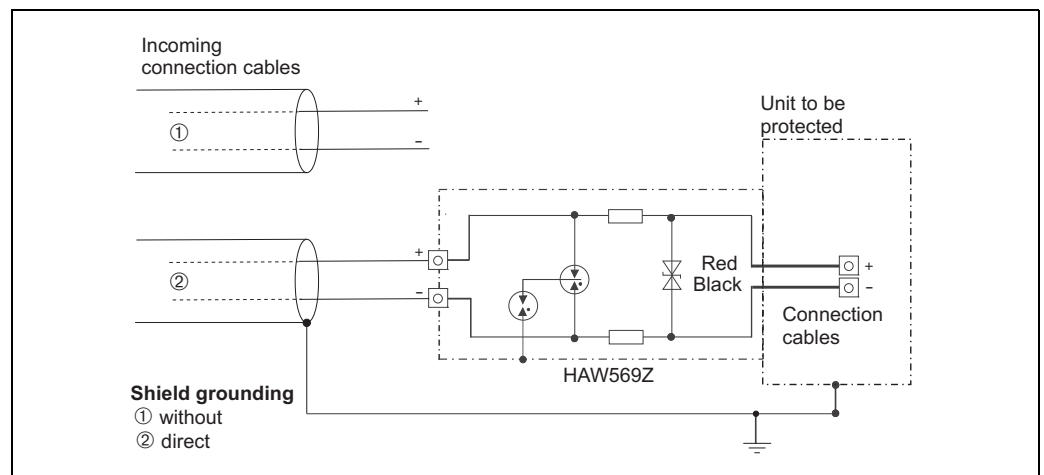

P01-xMx5xxxx-04-xx-xx-en-006

Operating conditions (Process)

Process temperature limits (temperature at transmitter)

- Process connections made of 316L:
–40 to +85°C (–40 to +185°F)
- Process connections made of C22.8:
–10 to +85°C (+14 to +185°F)

The process temperature at the transmitter can be reduced through the use of pulse lines.

Note!

- For oxygen applications, observe → [24](#) "Oxygen applications" section.
- Observe the Process temperature range of the seal.
→ See also the following section "Process temperature range, Seals".

Process temperature range, Seals

Feature 190 of the order code ¹	Seal	Process temperature range ²
A	FKM Viton	–20 to +85°C (–4 to +185°F)
C	PTFE	–40 to +85°C (–40 to +185°F)
F	NBR	–20 to +85°C (–4 to +185°F)
J	EPDM	–40 to +85°C (–40 to +185°F)

- 1) See product structure (→ [39](#))
- 2) Restrictions for oxygen applications, → [24](#)

Pressure specifications

- The maximum pressure for the measuring device is dependent on the lowest-rated element with regard to pressure, see the following sections for this:
 - → [7](#) ff, section "Measuring range"
 - → chapter "Mechanical construction".
 The MWP (maximum working pressure) is specified on the nameplate. This value refers to a reference temperature of 20°C (68°F) or 100°F (38 °C) for ANSI flanges and may be applied to the device for an unlimited time. Observe pressure-temperature dependency.
- The pressure values permitted at higher temperatures can be found in the following standards:
 - EN 1092-1: 2001 Tab. 18
 - ASME B 16.5a – 1998 Tab. 2-2.2 F316
 - ASME B 16.5a – 1998 Tab. 2.3.8 N10276
 - JIS B 2220
- The MWP applies for the temperature ranges specified in the "Ambient temperature range" (→ [25](#)) and "Process temperature limits" (see above) sections.
- The test pressure corresponds to the over pressure limit of the measuring instrument (Over pressure limits OPL = 1.5 x MWP) and may fit only temporally limited, so that no permanent damage develops.
- The Pressure Equipment Directive (EC Directive 97/23/EC) uses the abbreviation "PS". The abbreviation "PS" corresponds to the MWP (maximum working pressure) of the measuring device.
- In the case of sensor range and process connections where the OPL (Over Pressure Limit) of the pressure connection is smaller than the nominal value of the sensor, the device is set at the factory, at the very maximum, to the OPL value of the process connection. If you want to use the entire sensor range, select a process connection with a higher OPL value (1.5 x PN; PN = MWP).
- In oxygen applications, the values for p_{\max} and T_{\max} for oxygen applications" → [24](#), "Oxygen applications" may not be exceeded.

Mechanical construction

Process connection

Oval flange, connection 1/4-18 NPT IEC61518

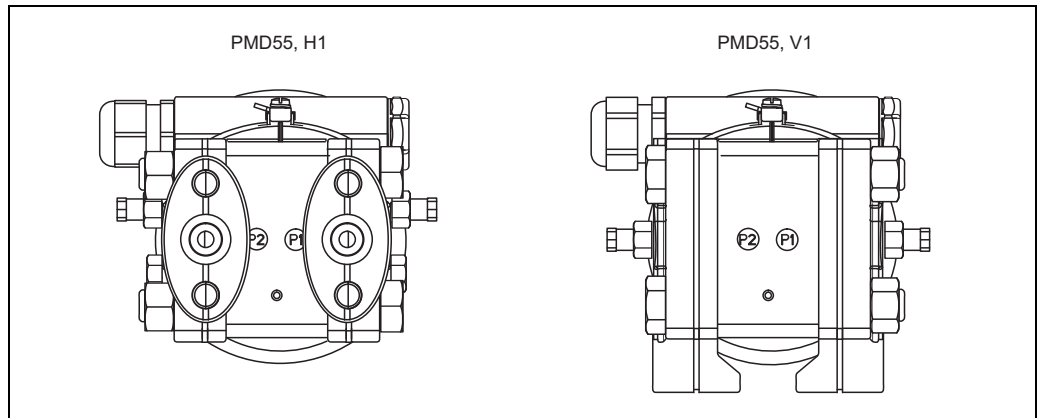

P01-PMD55xxx-11-xx-xx-xx-015

Designation of the process connections "P1" and "P2"

Factory setting

- P1: High pressure side (+)
- P2: Low pressure side (-)

This setting can be changed via a DIP switch in the connection department of the instrument and via the operating menu:

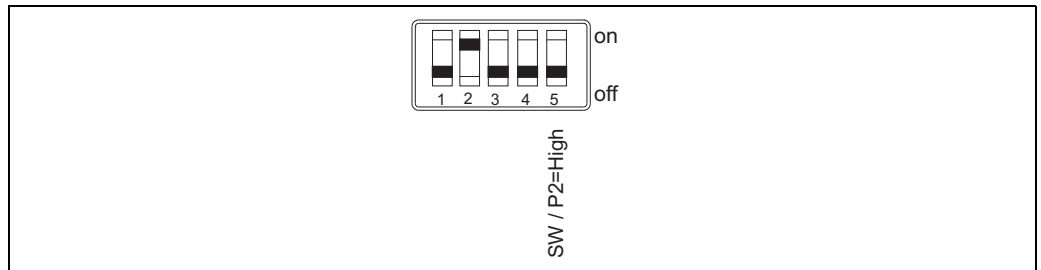

P01-PMD55xxx-04-xx-xx-xx-011

DIP switches in the connection compartment of the device. DIP switch 5 defines the high pressure side.

- DIP5 = off: The high pressure side is defined in the operating menu.
Menu "Setup", parameter 006: "High pressure side"; default: P1)
- DIP 5 = on: P2 is the high pressure side, independent of the setting in the operating menu.

Dimensions V1 version;
Impulse pipe vertical;
alignment 90°

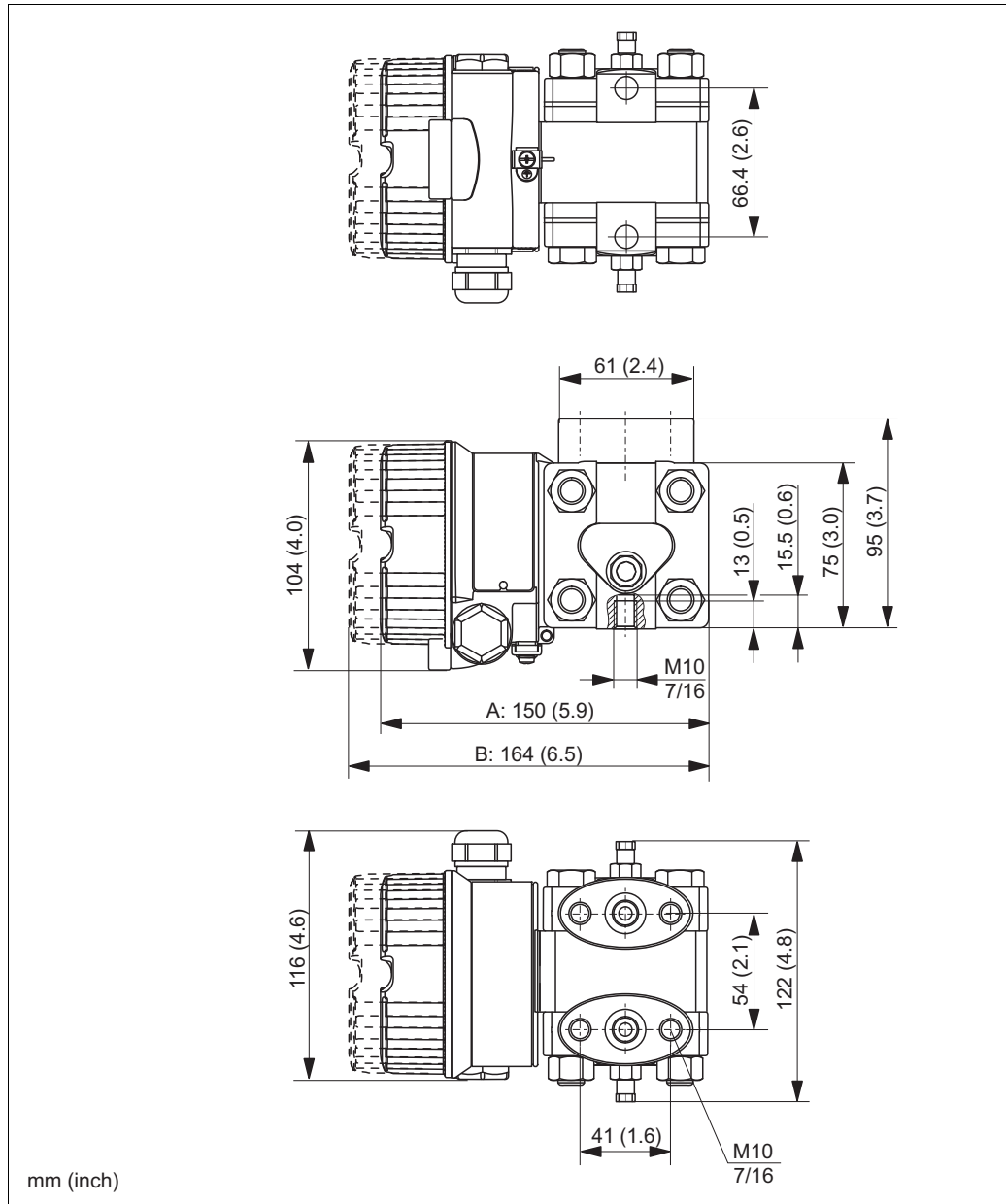

A: Version cover without window glass
B: Version cover with window glass

This drawing is valid for the following options in feature 110 ("Process Connection") of the product structure:
HAJ, HA4, HBJ, HB4

**Dimensions H1 version;
Impulse pipe horizontal;
alignment 180°**

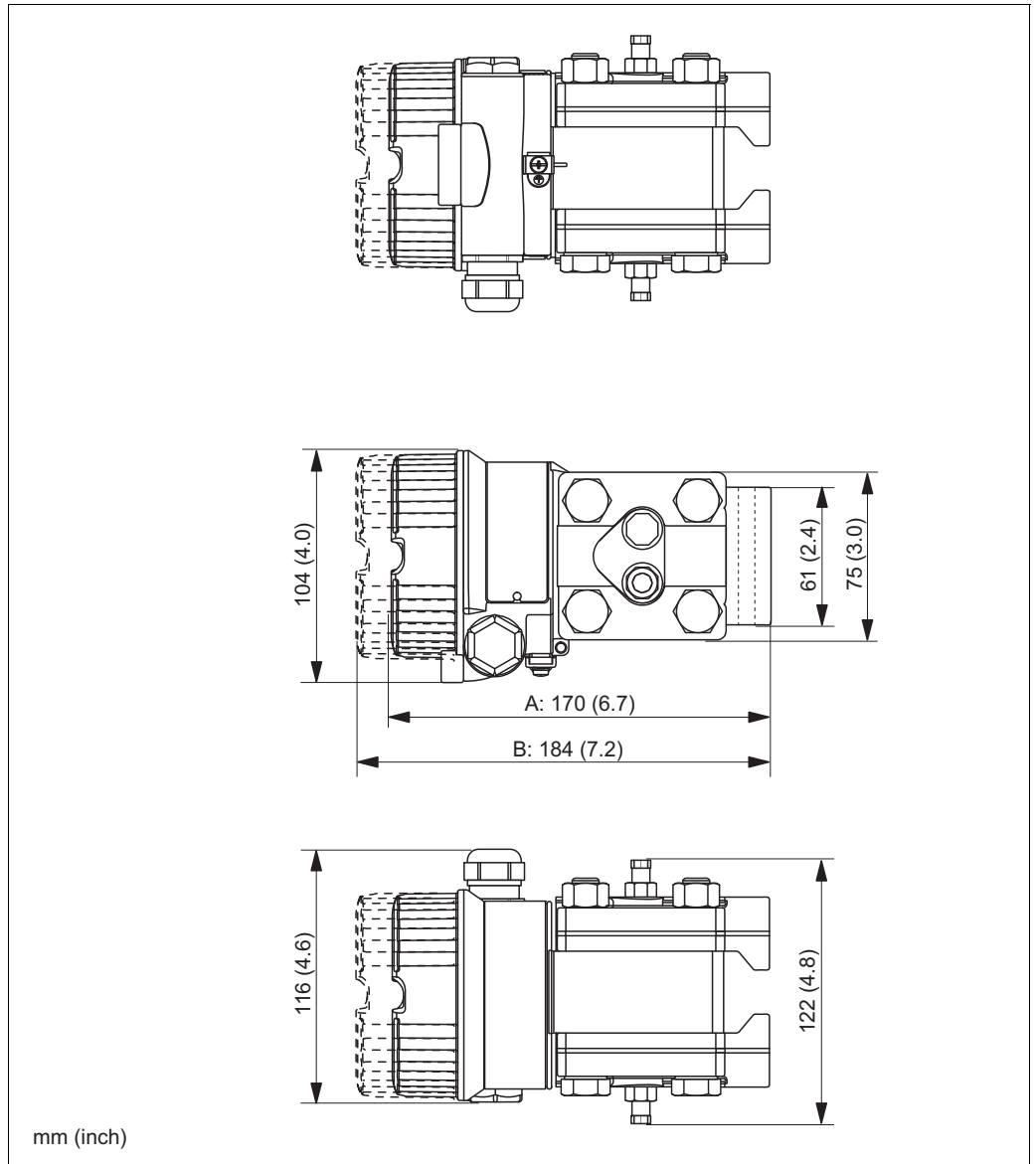

*A: Version cover without window glass
B: Version cover with window glass*

*This drawing is valid for the following options in feature 110 ("Process Connection") of the product structure:
HGJ, HG4, HHI, HH4*

Dimensions H2 version;
Impulse pipe horizontal;
alignment 90°

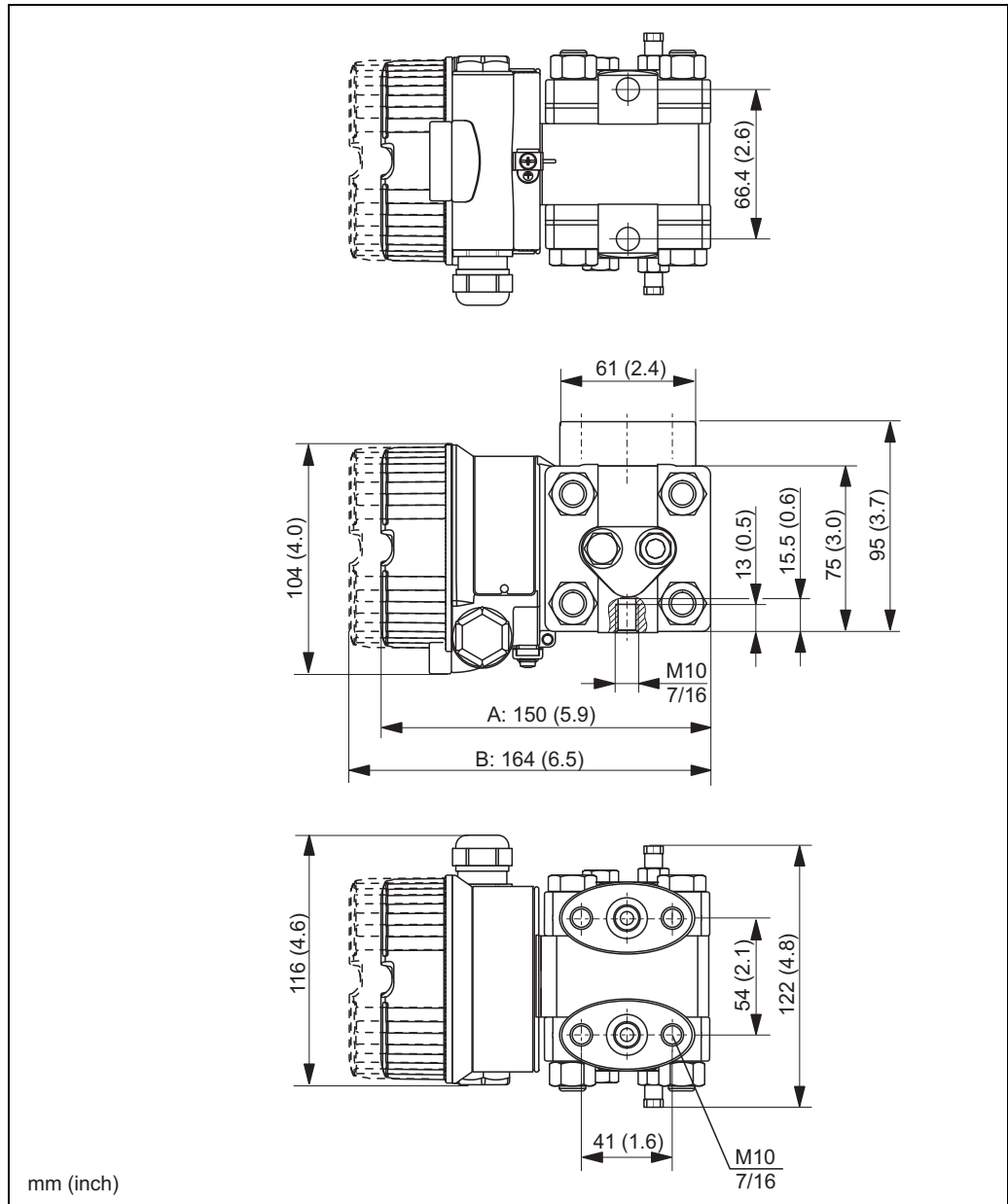

A: Version cover without window glass

B: Version cover with window glass

This drawing is valid for the following options in feature 110 ("Process Connection") of the product structure:
HNI, HN4, HOJ, HO4

Weight

Housing

- including electronics and cover without window glass: 1.0 kg (2.21 lbs)
- including electronics and cover with window glass: 1.1 kg (2.43 lbs)

Process connections

in preparation

Material (not wetted)

Housing

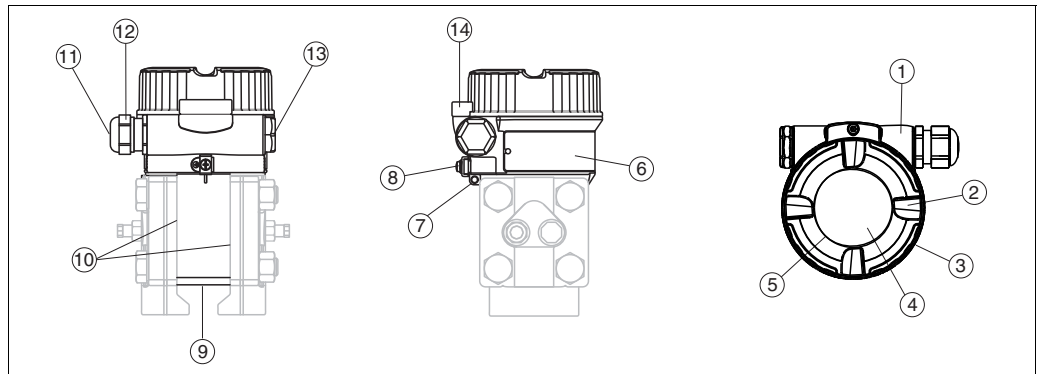

Front view, right-hand side view, top view.

Item number	Component part	Material
1	F30 housing, RAL 5012 (blue)	Die-cast aluminum with protective powder-coating on polyester base
2	Cover, RAL 7035 (gray)	Die-cast aluminum with protective powder-coating on polyester base
3	Cover seal	EPDM
4	Sight glass	Mineral glass
5	Sight glass seal	Silicone (VMQ)
6	External ground terminal	AISI 304 (1.4301)
7	Nameplates	Plastic film
8	Attachement for tie-on label	AISI 304 (1.4301)/ AISI 316 (1.4401)
9	Pressure compensation filter	Silicone
10	Sealing ring	EPDM
11	Seal of cable gland and blind plug	EPDM/NBR
12	Cable gland	Polyamide (PA) or CuZn nickel-plated
13	Blind plug	PBT-GF30 FR
		for dust ignition-proof, Ex d, FM XP and CSA XP: AISI 316L (1.4435)
14	Cover clamp	Clamp AISI 316L (1.4435), screw A4

Filling oil

- Silicone oil
- Inert oil

Connecting parts

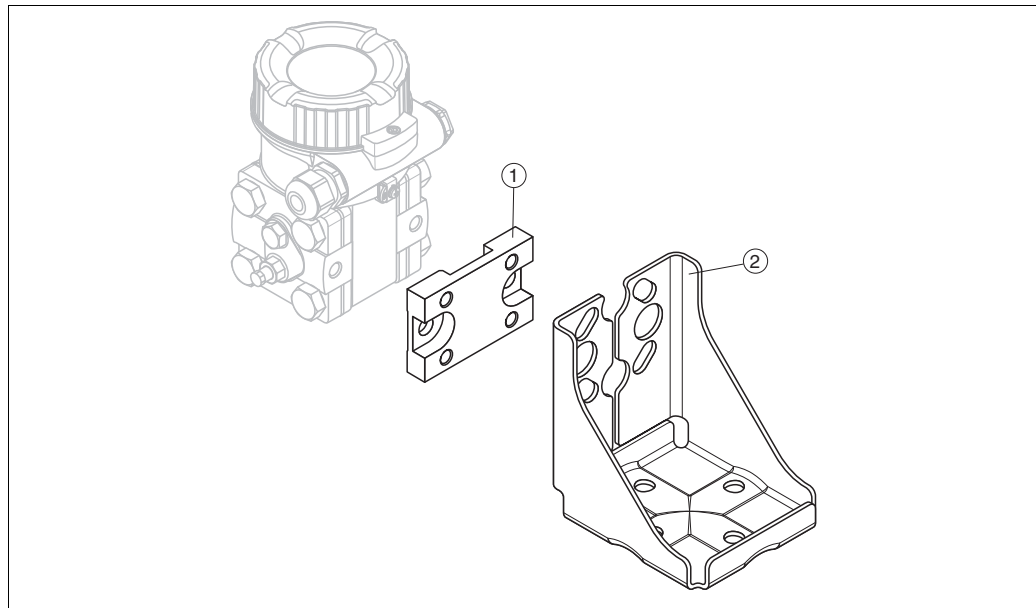

P01-PMD55xxx-06-09-xx-xx-001

Item number	Component part	Material
1	Adapter plate	AISI 304
2	Mounting bracket	AISI 304
		Screw and nuts A2-70

Material (wetted)

Side flanges

Endress+Hauser supplies side flanges made of stainless steel AISI 316L as per material numbers 1.4435 or 1.4404. With regard to their stability-temperature property, the materials 1.4435 and 1.4404 are grouped together under 13EO in EN 1092-1 Tab. 18. The chemical composition of the two materials can be identical.

Oval flange adapters

AISI 316L (1.4404) or C22.8 (1.0460)

Vent valves

AISI 316L (1.4404)

Human interface

Local operation

Operating keys and elements located on the electronic insert

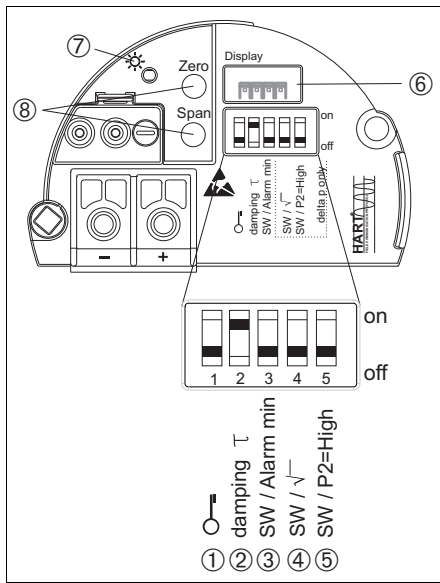

P01-Mxxxxxxx-19-xx-xx-xx-012

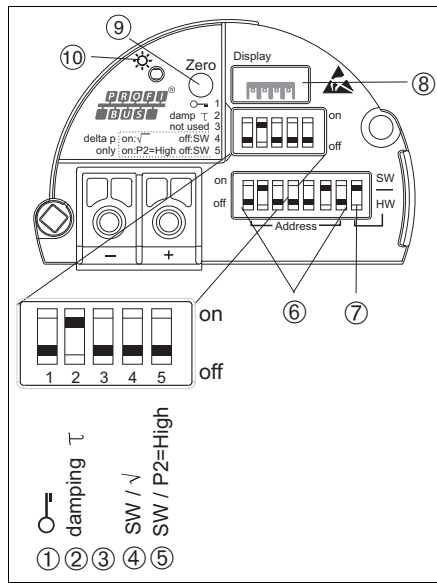

P01-Mxxxxxxx-19-xx-xx-xx-013

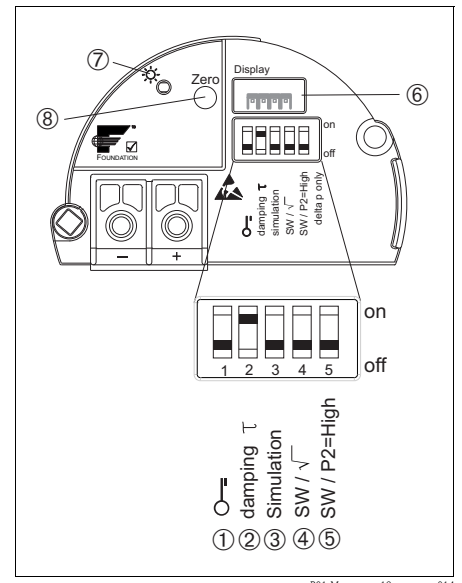

P01-Mxxxxxxx-19-xx-xx-xx-014

HART electronic insert

- 1 DIP switch for locking/unlocking parameters relevant to the measured value
- 2 DIP switch for switching damping on/off
- 3 DIP switch for alarm current SW / Alarm Min (3.6 mA)
- 4 DIP switch for defining operating mode and output characteristics
- 5 DIP switch for defining high pressure side
- 6 Slot for optional local display
- 7 Green LED to indicate successful operation
- 8 Operating keys for lower range value (zero) and upper range value (span)

PROFIBUS PA electronic insert

- 1 DIP switch for locking/unlocking parameters relevant to the measured value
- 2 DIP switch for switching damping on/off
- 3 Not used
- 4 DIP switch for defining operating mode and output characteristics
- 5 DIP switch for defining high pressure side
- 6 DIP-switch for hardware address
- 7 DIP-switch for bus address SW / HW
- 8 Slot for optional local display
- 9 Operating key for position zero adjustment or reset (Zero)
- 10 Green LED to indicate successful operation

FOUNDATION Fieldbus electronic insert

- 1 DIP switch for locking/unlocking parameters relevant to the measured value
- 2 DIP switch for switching damping on/off
- 3 DIP-switch for simulation mode
- 4 DIP switch for defining operating mode and output characteristics
- 5 DIP switch for defining high pressure side
- 6 Slot for optional local display
- 7 Green LED to indicate successful operation
- 8 Operating key for position zero adjustment or reset (Zero)

Function of the DIP switches

Switch	Symbol/label	Switching position	
		"off"	"on"
1		The device is unlocked. Measured-value-relevant parameters can be changed.	The device is locked. Measured-value-relevant parameters can not be changed.
2	damping τ	The damping is switched off. The output signal reacts immediately to changes of the measured value.	The damping is switched on. The output signal reacts to changes of the measured value with the delay time τ . ¹
3 (HART)	SW/Alarm min	The alarm current is as defined in the operating menu.	The alarm current is 3,6 mA irrespective of the setting in the operating menu.
3 (FF)	Simulation	The simulation mode is switched off (Factory setting).	The simulation mode is switched on.
4	SW/√	The output characteristics is as defined in the operating menu.	The output characteristic is "Square root", irrespective of the settings in the operating menu.
5	SW/P2= High	The high pressure side is as defined in the operating menu.	The high pressure side is allocated to the P2 pressure connection, irrespective of the setting in the operating menu.

1) The value of the delay time can be set in the operating menu. Factory setting: $\tau = 2$ s or as per order specifications.

Function of the operating keys

Note!

The operation via the keys on the electronic insert is only possible if the onsite display is not connected.

Key(s)	HART	PROFIBUS PA	FOUNDATION Fieldbus
"Zero" pressed for at least 3 seconds	Get Lower Range Value (LRV)	Get Lower Range Value (LRV)	Get Lower Range Value (LRV)
"Span" pressed for at least 3 seconds	Get Upper Range Value (URV)	—	—
"Zero" and "Span" Pressed simultaneously for at least 3 seconds	Position zero adjustment	—	—
"Zero" and "Span" Pressed simultaneously for at least 12 seconds	Reset	—	—
"Zero" pressed for at least 12 seconds	—	Reset	Reset

Local display (optional)

A 4-line liquid crystal display (LCD) is used for display and operation. The local display shows measured values, dialog texts as well as fault and notice messages in plain text, thereby supporting the user at every stage of operation. The liquid crystal display of the device can be turned in 90° stages. Depending on the orientation of the device, this makes it easy to operate the device and read the measured values.

Functions

- 8-digit measured value display including sign and decimal point, bar graph for 4 to 20 mA HART as current display; or for PROFIBUS PA as graphic display of the standardized value of the AI Block; for FOUNDATION Fieldbus as graphic display of the transducer output in relation to the set pressure range.
- Three keys for operation
- Simple and complete menu guidance as parameters are split into several levels and groups
- Each parameter is given a 3-digit ID number for easy navigation
- Possibility of configuring the display to suit individual requirements and preferences, such as language, alternating display, contrast setting, display of other measured values such as sensor temperature etc.
- Comprehensive diagnostic functions (fault and warning message, peak-hold indicators etc.)

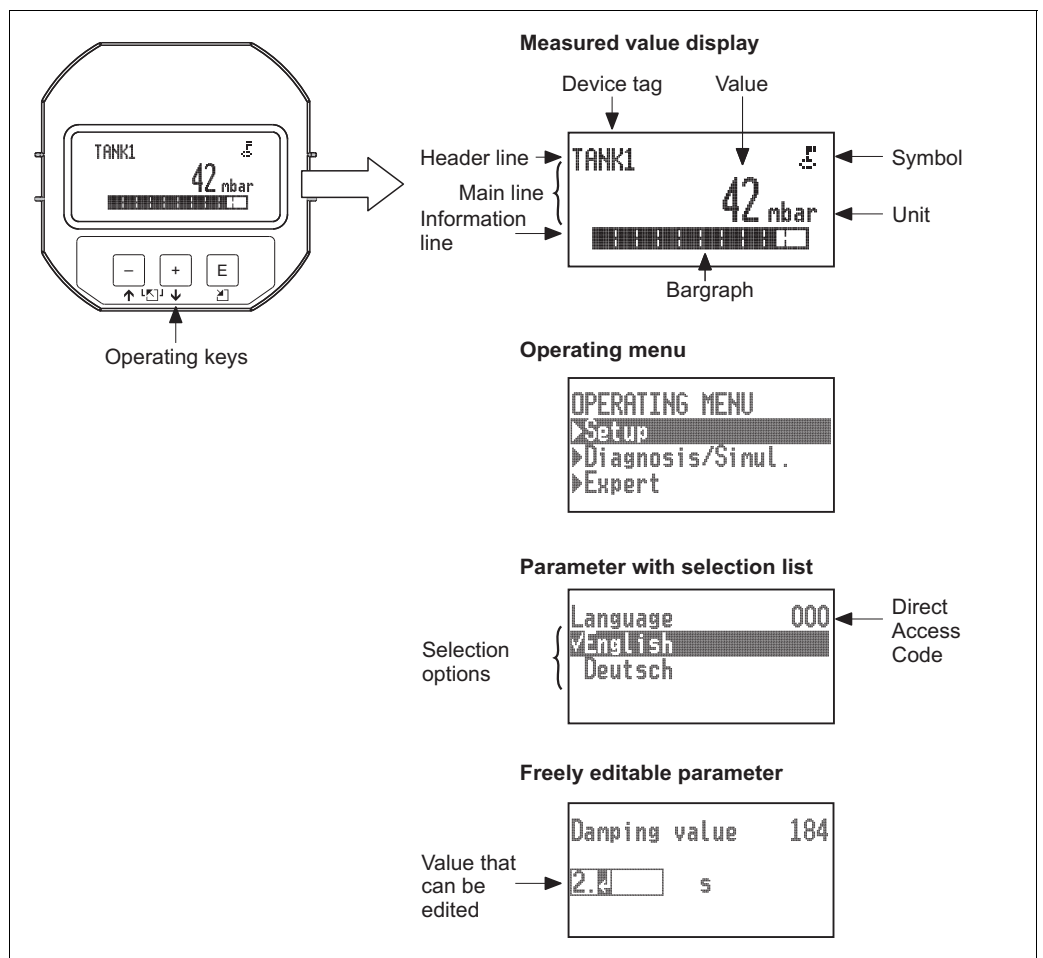

P01-Mxxxxxxx-07-xx-xx-en-002

Remote operation

All software parameters are accessible depending on the position of the write protection switch on the device.

HART

Remote operation via:

- Field Communicator 375 handheld terminal see "Hardware and software for onsite and remote operation" section → 37).
- FieldCare (see "Hardware and software for onsite and remote operation" section → 37 ff) with Commubox FXA195 (see "Hardware and software for onsite and remote operation" section → 37 ff)
- Field Xpert. Field Xpert is an industrial PDA with integrated 3.5" touchscreen from Endress+Hauser based on Windows Mobile. It communicates via wireless with the optional VIATOR Bluetooth modem connected to a HART device point-to-point or wireless via WiFi and Endress+Hauser's Fieldgate FXA520. Field Xpert also works as a stand-alone device for asset management applications. For details refer to BA00060S/00/EN.

PROFIBUS PA

Remote operation via:

- FieldCare (see "Hardware and software for onsite and remote operation" section → 37 ff)
 - Profiboard: For connecting a PC to PROFIBUS
 - Proficard: For connecting a laptop to PROFIBUS

FOUNDATION Fieldbus

Remote operation via:

- Handheld terminal Field Communicator 375 (see "Hardware and software for onsite and remote operation" section → 37 ff)
- Use an FF-configuration program for example NI-FBUS Configurator, to
 - connect devices with "FOUNDATION Fieldbus signal" into an FF-network
 - set FF-specific parameters
 Operation with NI-FBUS Configurator:
 The NI-FBUS Configurator is an easy-to-use graphical environment for creating linkages, loops, and a schedule based on the fieldbus concepts.
 You can use the NI-FBUS Configurator to configure a fieldbus network as follows:
 - Set block and device tags
 - Set device addresses
 - Create and edit function block control strategies (function block applications)
 - Configure vendor-defined function and transducer blocks
 - Create and edit schedules
 - Read and write to function block control strategies (function block applications)
 - Invoke Device Description (DD) methods
 - Display DD menus
 - Download a configuration
 - Verify a configuration and compare it to a saved configuration
 - Monitor a downloaded configuration
 - Replace a virtual device by a real device
 - Save and print a configuration
- FieldCare (see "Hardware and software for onsite and remote operation" → 37 ff)
 - NI PCMCIA-FBUS series 2 to connect a laptop to FF.

Note!

For further information please contact your local Endress+Hauser Sales Center.

Hardware and software for onsite and remote operation

Commubox FXA195

For intrinsically safe HART communication with FieldCare via the USB interface. For details refer to TI00404F/00/EN.

Field Communicator 375

With a handheld terminal, all the parameters can be configured anywhere along the bus line via menu operation (HART and FOUNDATION Fieldbus).

FieldCare

FieldCare is an Endress+Hauser asset management tool based on FDT technology. With FieldCare, you can configure all Endress+Hauser devices as well as devices from other manufacturers that support the FDT standard.

FieldCare supports the following functions:

- Configuration of transmitters in offline and online mode
- Loading and saving device data (upload/download)
- Documentation of the measuring point

Connection options:

- HART via Commubox FXA195 and the USB port on a computer
- PROFIBUS PA via segment coupler and PROFIBUS interface card
- FOUNDATION Fieldbus via NI interface card

For further information → www.endress.com

Certificates and approvals

CE mark	The device meets the legal requirements of the relevant EC directives. Endress+Hauser confirms that the device has been successfully tested by applying the CE mark.
Ex approvals	<ul style="list-style-type: none"> ■ ATEX ■ FM ■ CSA ■ NEPSI ■ IECEX <p>All explosion protection data are given in separate documentation which is available upon request. The Ex documentation is supplied as standard with all devices approved for use in explosion hazardous areas. → 42 ff, sections "Safety Instructions" and "Installation/Control Drawings".</p>
Marine certificate (in preparation)	<ul style="list-style-type: none"> ■ Germanischer Lloyd (GL) ■ American Bureau of Shipping (ABS)
CRN approval	Some device versions have CRN approval. For a CRN-approved device, a CRN-approved process connection (→ 39 ff, feature 110 "Process connection") has to be ordered with a CSA approval (→ 39 ff, feature 10 "Approval"). These devices are fitted with a separate plate bearing the registration number 0F13907.5C.
Pressure Equipment Directive (PED)	PMD55 corresponds to Article 3 (3) of the EC directive 97/23/EC (Pressure Equipment Directive) and has been designed and manufactured according to good engineering practice.
Standards and guidelines	<p>DIN EN 60770 (IEC 60770): Transmitters for use in industrial-process control systems Part 1: Methods for inspection and routine testing</p> <p>DIN 16086: Electrical pressure measuring instruments, pressure sensors, pressure transmitters, pressure measuring instruments, concepts, specifications in data sheets</p> <p>EN 61326-X: EMC product family standard for electrical equipment for measurement, control and laboratory use.</p>

Ordering information

PMD55

This overview does not mark options which are mutually exclusive.

010	Approval:
AA	Non-hazardous area
BA	ATEX II 1/2 G Ex ia IIC T6
BB	ATEX II 1/2 D Ex t IIIC
BC	ATEX II 2 G Ex d IIC T6
BD	ATEX II 3G Ex nA IIC T6
B1	ATEX II 1/2 G Ex ia IIC T6 + ATEX II 1/2 D Ex iaD
CA	CSA C/US IS Cl.I,II,III Div.1 Gr.A-G, CSA C/US IS Cl.I Div.2 Gr.A-D, Ex ia, C: Zone 0,1,2/US: Zone 0,1,2,20,21,22
CB	CSA C/US XP Cl.I,II Div.1 Gr.B-G, Ex d, (Conduit seal not required), Zone 1,2
CC	CSA C/US Cl.II,III Div.1 Gr.E-G, US: Zone 21,22
CD	CSA General Purpose
C1	CSA C/US IS/XP Cl.I,II Div.1 Gr.A-G/B-G, Zone 1,2
FA	FM IS Cl.I,II,III Div.1 Gr.A-G, AEx ia, FM NI Cl.I Div.2 Gr.A-D, FM IS: Zone 0,1,2,20,21,22/FM NI: Zone 2
FB	FM XP Cl.I,II Div.1 Gr.A-G Zone 1 IIC T6 (Conduit seal not required), Zone 1,2
FC	FM DIP Cl.I,III Div.1 Gr.E-G, Zone 21,22
FD	FM NI Cl.I Div.2 Gr.A-D, Zone 2
F1	FM IS/XP Cl.I,II Div.1 Gr.A-G, Zone 1,2
IA	IEC Ex ia IIC T6 Ga/Gb
IB	IEC Ex d IIC T6 Gb
ID	IEC Ex t IIIC Da/Db
IE	IEC Ex ic IIC T6 Gc
I1	IEC Ex ia IIC T6 Ga/Gb + Ex ia IIIC Da/Db
NA	NEPSI Ex ia IIC T6
NB	NEPSI Ex d IIC T6
8A	ATEX II Ex ia/Ex d + FM/CSA IS + XP ATEX II 1/2G Ex ia IIC T6+ ATEX II 2G Ex d IIC T6+FM/CSA IS + XP Cl.I,II Div.1 Gr.A-G/B-G, FM/CSA: Zone 1,2
8B	FM/CSA IS + XP Cl.I,II Div.1 Gr.A-D/B-G FM IS/FM XP Cl.I,II Div.1 Gr.A-G + CSA IS/XP Cl.I,II Div.1 Gr.A-G, FM/CSA: Zone 1,2
020	Output:
2	4-20mA HART
3	PROFIBUS PA
4	FOUNDATION Fieldbus
030	Display, Operation:
1	LCD, push button on display electronics
2	W/o LCD, push button on electronics
040	Housing:
A	F30 Alu
B	F30 Alu, Glass window
050	Electrical Connection:
A	Gland M20 IP66/68, NEMA4X/6P
B	Thread M20 IP66/68, NEMA4X/6P
C	Thread G1/2 IP66/68, NEMA4X/6P
D	Thread NPT1/2 IP66/68, NEMA4X/6P
I	Plug M12, IP66/68, NEMA4X/6P
M	Plug 7/8, IP66/68, NEMA4X/6P
P	Plug Han7D, 90deg, IP65
V	Ventil plug ISO4400 M16, IP64
060	Nominal Pressure PN:
D	Prepared for Deltatop
2	1bar/100kPa/14.5psi
6	70bar/7MPa/1015psi
7	160bar/16MPa/2400psi
070	Sensor Nominal Value:
7B	10mbar/1kPa/0.15psi
7C	30mbar/3kPa/0.45psi
7D	100mbar/10kPa/1.5psi
7F	500mbar/50kPa/7.5psi
7G	1bar/100kPa/15psi
7H	3bar/300kPa/45psi
7L	16bar/1.6MPa/240psi
7M	40bar/4MPa/600psi

070	Sensor Nominal Value:
88	Prepared for Deltatop
080	Reference Accuracy:
D	Platinum
G	Standard
090	Calibration; Unit:
B	Nominal value; mbar/bar
C	Nominal value; kPa/MPa
D	Nominal value; mm/mH2O
E	Nominal value; inH2O/ftH2O
F	Nominal value; psi
J	Customised pressure; see additional spec.
K	Customised level; see additional spec.
L	Customised flow; see additional spec.
8	Adjusted for Deltatop; see additional spec.
110	Process Connection:
HAI	NPT1/4-18 IEC61518 UNF7/16-20; 316L, V1, Installation impulse line vertical, Alignment 90°
HA4	NPT1/4-18 IEC61518 UNF7/16-20; C22.8, V1, Installation impulse line vertical, Alignment 90°
HBJ	NPT1/4-18 IEC61518 M10, 316L, V1, Installation impulse line vertical, Alignment 90°
HB4	NPT1/4-18 IEC61518 M10; C22.8, V1, Installation impulse line vertical, Alignment 90°
HGJ	NPT1/4-18 IEC61518 UNF7/16-20, 316L, H1, Installation impulse line horizontal, Alignment 180°
HG4	NPT1/4-18 IEC61518 UNF7/16-20, C22.8, H1, Installation impulse line horizontal, Alignment 180°
HHJ	NPT1/4-18 IEC61518 M10, 316L, H1, Installation impulse line horizontal, Alignment 180°
HH4	NPT1/4-18 IEC61518 M10, C22.8, H1, Installation impulse line horizontal, Alignment 180°
HNJ	NPT1/4-18 IEC61518 UNF7/16-20, 316L, H2, Installation impulse line horizontal, Alignment 90°
HN4	NPT1/4-18 IEC61518 UNF7/16-20, C22.8, H2, Installation impulse line horizontal, Alignment 90°
HOJ	NPT1/4-18 IEC61518 M10, 316L, H2, Installation impulse line horizontal, Alignment 90°
HO4	NPT1/4-18 IEC61518 M10, C22.8, H2, Installation impulse line horizontal, Alignment 90°

V1:
HAJ, HA4, HBJ, HB4

H1:
HGJ, HG4, HHJ, HH4

H2:
HNJ, HN4, HOJ, HO4

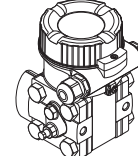
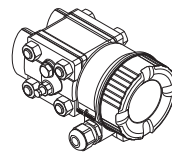
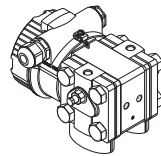

P01-PMD55xxx-11-xx-xx-xx-012

170	Process isolating diaphragm material:
A	316L
B	AlloyC
180	Fill Fluid:
1	Silicone oil
2	Inert oil
190	Seal:
A	FKM Viton
C	PTFE
F	NBR
J	EPDM

Additional ordering information (optional)

500	Additional Operation Language:
AA	English
AB	German
AC	French
AD	Spanish
AE	Italian
AF	Dutch
AK	Chinese
AL	Japanese
550	Calibration:
F1	Works calib. certificate 5-point
F2	DKD calib. certificate 10-point
570	Service (multiple options can be selected):
HA	Cleaned from oil+grease ¹⁾
HB	Cleaned for oxygen service ¹⁾
HC	Cleaned from PWIS (PIWS = paint wetting impairment substances) ¹⁾
IA	Adjusted min alarm current
IB	Adjusted HART Burst Mode PV
1) Only device, not accessory or enclosed accessory	
580	Test, Certificate (multiple options can be selected):
JA	EN10204-3.1 material wetted parts, inspection certificate
JB	NACE MR0175 wetted parts
JF	EN10204-3.1 AD2000 material wetted parts, expecting process membrane, inspection certificate
KD	EN10204-3.1 Helium leak test, inspection certificate
KE	EN10204-3.1 pressure test, inspection certificate
610	Accessory Mounted:
NA	Overvoltage protection
620	Accessory Enclosed (multiple options can be selected):
PB	Mounting bracket + adapter plate; wall/pipe mounting, 304
PC	Adapter plate, wall/pipe mounting, 304
P1	Oval flange (PZO), see additional spec.
850	Firmware version:
78	01.00.zz, HART, DevRev01
895	Marking:
Z1	Tagging (TAG), see additional spec.
Z2	Bus address, see additional spec.

Additional documentation

Technical Information

- EMC test procedures TI00241F/00/EN
- Cerabar M: TI00436P/00/EN
- Deltapilot M: TI00437P/00/EN

Operating Instructions

- 4 to 20 mA HART: BA00382P/00/EN
- PROFIBUS PA: BA00383P/00/EN
- FOUNDATION Fieldbus: BA00384P/00/EN

Brief operating instruction

- 4 to 20 mA HART: KA01027P/00/EN
- PROFIBUS PA: KA01028P/00/EN
- FOUNDATION Fieldbus: KA01029P/00/EN

Safety Instructions

Authority	Version in the order code	Approval	Category	Electronics	Documentation
ATEX	BA	Ex ia IIC	II 1/2 G	– 4 to 20 mA HART – PROFIBUS PA – FOUNDATION Fieldbus	– XA00457P/00
	BB	Ex t IIIC	II 1/2 D	– 4 to 20 mA HART – PROFIBUS PA – FOUNDATION Fieldbus	– XA00458P/00
	BC	Ex d IIC	II 2G	– 4 to 20 mA HART – PROFIBUS PA – FOUNDATION Fieldbus	– XA00459P/00
	BD	Ex nA IIC	II 3 G	– 4 to 20 mA HART – PROFIBUS PA – FOUNDATION Fieldbus	– XA00461P/00
	B1	Ex ia IIC Ex ia D	II 1/2 G II 1/2 D	– 4 to 20 mA HART – PROFIBUS PA – FOUNDATION Fieldbus	– XA00460P/00
	8A	Ex ia IIC Ex d IIC	II 1/2 G II 2 G	– 4 to 20 mA HART	– XA00505P/00

Authority	Version in the order code	Approval	EPL	Electronics	Documentation
IECEx	IA	Ex ia IIC	Ga/Gb	– 4 to 20 mA HART – PROFIBUS PA – FOUNDATION Fieldbus	– XA00462P/00
	IB	Ex d IIIC	Gb	– 4 to 20 mA HART – PROFIBUS PA – FOUNDATION Fieldbus	– XA00463P/00
	ID	Ex t IIIC	Da/Db	– 4 to 20 mA HART – PROFIBUS PA – FOUNDATION Fieldbus	– XA00490P/00
	IE	Ex ic IIC	Gc	– 4 to 20 mA HART – PROFIBUS PA – FOUNDATION Fieldbus	– XA00492P/00
	I1	Ex ia IIC Ex ia IIIC	Ga/Gb Da/Db	– 4 to 20 mA HART – PROFIBUS PA – FOUNDATION Fieldbus	– XA00491P/00

Authority	Version in the order code	Approval	Electronics	Documentation
NEPSI	NA	Ex ia IIC	– 4 to 20 mA HART	– XA00534P/00
NEPSI	NB	Ex d IIC	– 4 to 20 mA HART	– XA00514P/00

Installation/Control Drawings

Authority	Version in the order code	Approval	Electronics	Documentation
FM	FA	IS Cl.I,II,III Div.1 Gr. A-G, AEx ia NI Cl. I Div.2 Gr.A-D	- 4 to 20 mA HART	- ZD00234P
	FB	FM XP Cl.I,II Div.1 Gr.A-G Zone 1 IIC T6 (Conduit seal not required), Zone 1,2	- 4 to 20 mA HART - PROFIBUS PA - FOUNDATION Fieldbus	-
CSA	CA	C/US IS Cl.I,II,III Div.1 Gr A-G C/US IS Cl.I Div.2 Gr A-D, Ex ia	- 4 to 20 mA HART	- ZD00237P

Configuration data sheet

Pressure

The following configuration data sheet has to be filled in and to be included in the order when the option "J: Customized pressure" has been selected in feature "090: Calibration; Unit" of the product structure.

Pressure Engineering Unit	
<input type="checkbox"/> mbar	<input type="checkbox"/> mmH ₂ O
<input type="checkbox"/> bar	<input type="checkbox"/> mmHg
<input type="checkbox"/> psi	<input type="checkbox"/> Pa
<input type="checkbox"/> mmH ₂ O	<input type="checkbox"/> kPa
<input type="checkbox"/> ftH ₂ O	<input type="checkbox"/> MPa
<input type="checkbox"/> inH ₂ O	<input type="checkbox"/> kgf/cm ²
Calibration Range / Output	
Low range value (LRV): _____	[pressure engineering unit]
Upper range value (URV): _____	[pressure engineering unit]
Display Information	
1st Value Display	2nd Value display ¹⁾
Main Value	<input type="checkbox"/> none (default)
	<input type="checkbox"/> Pressure
	<input type="checkbox"/> Current [mA]
	<input type="checkbox"/> Temperature
	<input type="checkbox"/> Measured value (%)
Damping	
Damping: ____ sec (Default 2 sec)	
¹⁾ Depending on sensor and communication variant	

P01-xxxxxxx-16-xx-xx-en-001

Note!
Smallest span (factory calibration) → 7.

Level

The following configuration data sheet has to be filled in and to be included in the order when the option "K: Customized level" has been selected in feature "090: Calibration; Unit" of the product structure.

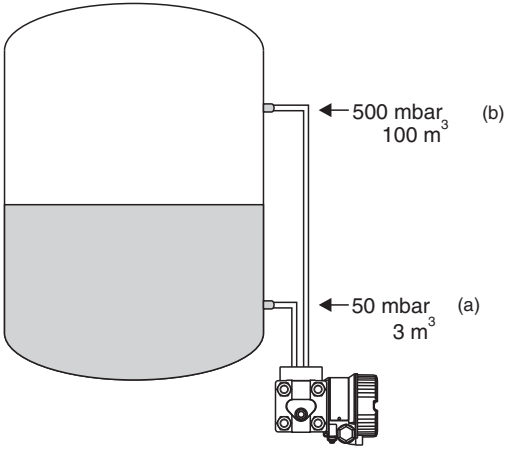
<p>Pressure Engineering Unit</p> <table border="0" style="width: 100%;"> <tr> <td><input type="checkbox"/> mbar</td> <td><input type="checkbox"/> mmH₂O</td> </tr> <tr> <td><input type="checkbox"/> bar</td> <td><input type="checkbox"/> mH₂O</td> </tr> <tr> <td><input type="checkbox"/> psi</td> <td><input type="checkbox"/> ftH₂O</td> </tr> <tr> <td><input type="checkbox"/> mmHg</td> <td><input type="checkbox"/> inH₂O</td> </tr> <tr> <td><input type="checkbox"/> kgf/cm²</td> <td><input type="checkbox"/> Pa</td> </tr> <tr> <td><input type="checkbox"/> kPa</td> <td><input type="checkbox"/> MPa</td> </tr> </table>	<input type="checkbox"/> mbar	<input type="checkbox"/> mmH ₂ O	<input type="checkbox"/> bar	<input type="checkbox"/> mH ₂ O	<input type="checkbox"/> psi	<input type="checkbox"/> ftH ₂ O	<input type="checkbox"/> mmHg	<input type="checkbox"/> inH ₂ O	<input type="checkbox"/> kgf/cm ²	<input type="checkbox"/> Pa	<input type="checkbox"/> kPa	<input type="checkbox"/> MPa	<p>Output Unit (Scaled unit)</p> <table border="0" style="width: 100%;"> <tr> <td><input type="checkbox"/> %</td> <td><input type="checkbox"/> m</td> <td><input type="checkbox"/> l</td> <td><input type="checkbox"/> gal</td> </tr> <tr> <td></td> <td><input type="checkbox"/> dm</td> <td><input type="checkbox"/> hl</td> <td><input type="checkbox"/> lgal</td> </tr> <tr> <td></td> <td><input type="checkbox"/> cm</td> <td></td> <td></td> </tr> <tr> <td></td> <td><input type="checkbox"/> mm</td> <td><input type="checkbox"/> m³</td> <td><input type="checkbox"/> ft³</td> </tr> <tr> <td></td> <td></td> <td></td> <td><input type="checkbox"/> in³</td> </tr> <tr> <td><input type="checkbox"/> inch</td> <td></td> <td></td> <td><input type="checkbox"/> kg</td> </tr> <tr> <td><input type="checkbox"/> ft</td> <td></td> <td></td> <td><input type="checkbox"/> t</td> </tr> <tr> <td></td> <td></td> <td></td> <td><input type="checkbox"/> lb</td> </tr> </table>	<input type="checkbox"/> %	<input type="checkbox"/> m	<input type="checkbox"/> l	<input type="checkbox"/> gal		<input type="checkbox"/> dm	<input type="checkbox"/> hl	<input type="checkbox"/> lgal		<input type="checkbox"/> cm				<input type="checkbox"/> mm	<input type="checkbox"/> m ³	<input type="checkbox"/> ft ³				<input type="checkbox"/> in ³	<input type="checkbox"/> inch			<input type="checkbox"/> kg	<input type="checkbox"/> ft			<input type="checkbox"/> t				<input type="checkbox"/> lb
<input type="checkbox"/> mbar	<input type="checkbox"/> mmH ₂ O																																												
<input type="checkbox"/> bar	<input type="checkbox"/> mH ₂ O																																												
<input type="checkbox"/> psi	<input type="checkbox"/> ftH ₂ O																																												
<input type="checkbox"/> mmHg	<input type="checkbox"/> inH ₂ O																																												
<input type="checkbox"/> kgf/cm ²	<input type="checkbox"/> Pa																																												
<input type="checkbox"/> kPa	<input type="checkbox"/> MPa																																												
<input type="checkbox"/> %	<input type="checkbox"/> m	<input type="checkbox"/> l	<input type="checkbox"/> gal																																										
	<input type="checkbox"/> dm	<input type="checkbox"/> hl	<input type="checkbox"/> lgal																																										
	<input type="checkbox"/> cm																																												
	<input type="checkbox"/> mm	<input type="checkbox"/> m ³	<input type="checkbox"/> ft ³																																										
			<input type="checkbox"/> in ³																																										
<input type="checkbox"/> inch			<input type="checkbox"/> kg																																										
<input type="checkbox"/> ft			<input type="checkbox"/> t																																										
			<input type="checkbox"/> lb																																										
<p>Empty pressure (a) Low pressure value (empty) _____ [pres. eng. unit]</p>	<p>Empty calibration (a) Low level value (empty) _____ [Scaled Unit]</p>																																												
<p>Full pressure (b) High pressure value (full) _____ [pres. eng. unit]</p>	<p>Full calibration (b) High level value (full) _____ [Scaled Unit]</p>																																												
<p>Display Information</p> <p>1st Value Display Measured Value (PV)</p> <p>2nd Value Display ¹⁾ (factory setting)</p> <table border="0" style="width: 100%;"> <tr> <td><input type="checkbox"/> none</td> </tr> <tr> <td><input type="checkbox"/> Pressure</td> </tr> <tr> <td><input type="checkbox"/> Current [mA]</td> </tr> <tr> <td><input type="checkbox"/> Temperature</td> </tr> <tr> <td><input type="checkbox"/> Measured value (%)</td> </tr> </table>	<input type="checkbox"/> none	<input type="checkbox"/> Pressure	<input type="checkbox"/> Current [mA]	<input type="checkbox"/> Temperature	<input type="checkbox"/> Measured value (%)	<p>Example</p> 																																							
<input type="checkbox"/> none																																													
<input type="checkbox"/> Pressure																																													
<input type="checkbox"/> Current [mA]																																													
<input type="checkbox"/> Temperature																																													
<input type="checkbox"/> Measured value (%)																																													
<p>Damping</p> <p>Damping: ____ sec (Default 2 sec)</p>																																													
<p>¹⁾ Depending on sensor and communication variant</p>																																													

P01-PMD55xxx-16-xx-xx-en-001

Flow

The following configuration data sheet has to be filled in and to be included in the order when the option "L: Customized flow" has been selected in feature "090: Calibration; Unit" of the product structure.

<p>Pressure Engineering Unit</p> <p><input type="checkbox"/> mbar <input type="checkbox"/> mmH₂O <input type="checkbox"/> bar <input type="checkbox"/> mH₂O <input type="checkbox"/> psi <input type="checkbox"/> ftH₂O <input type="checkbox"/> mmHg <input type="checkbox"/> inH₂O</p> <p><input type="checkbox"/> mmHg <input type="checkbox"/> Pa <input type="checkbox"/> kgf/cm² <input type="checkbox"/> kPa <input type="checkbox"/> MPa</p>	<p>Flow Unit / Measured Value (PV)</p> <table style="width: 100%; border-collapse: collapse;"> <tr> <td style="width: 33%; border: none;"><input type="checkbox"/> Mass</td> <td style="width: 33%; border: none;"><input type="checkbox"/> Volume</td> <td style="width: 33%; border: none;"><input type="checkbox"/> Percent</td> </tr> <tr> <td style="border: none;"></td> <td style="border: none;"> <table border="1" style="width: 100%; border-collapse: collapse;"> <thead> <tr> <th style="width: 25%;">Operation Condition</th> <th style="width: 25%;">Norm Condition</th> <th style="width: 25%;">Standard Condition</th> <th style="width: 25%;"></th> </tr> </thead> <tbody> <tr> <td><input type="checkbox"/> kg/s</td> <td><input type="checkbox"/> m³/s</td> <td><input type="checkbox"/> Nm³/s</td> <td><input type="checkbox"/> Sm³/s</td> </tr> <tr> <td><input type="checkbox"/> kg/min</td> <td><input type="checkbox"/> m³/min</td> <td><input type="checkbox"/> Nm³/min</td> <td><input type="checkbox"/> Sm³/min</td> </tr> <tr> <td><input type="checkbox"/> kg/h</td> <td><input type="checkbox"/> m³/h</td> <td><input type="checkbox"/> Nm³/h</td> <td><input type="checkbox"/> Sm³/h</td> </tr> <tr> <td><input type="checkbox"/> t/s</td> <td><input type="checkbox"/> l/s</td> <td><input type="checkbox"/> Nm³/d</td> <td><input type="checkbox"/> Sm³/d</td> </tr> <tr> <td><input type="checkbox"/> t/min</td> <td><input type="checkbox"/> l/min</td> <td></td> <td><input type="checkbox"/> SCFS</td> </tr> <tr> <td><input type="checkbox"/> t/h</td> <td><input type="checkbox"/> l/h</td> <td></td> <td><input type="checkbox"/> SCFM</td> </tr> <tr> <td><input type="checkbox"/> oz/s</td> <td><input type="checkbox"/> US Gal/s</td> <td></td> <td><input type="checkbox"/> SCFH</td> </tr> <tr> <td><input type="checkbox"/> oz/min</td> <td><input type="checkbox"/> US Gal/min</td> <td></td> <td><input type="checkbox"/> SCFD</td> </tr> <tr> <td><input type="checkbox"/> lb/s</td> <td><input type="checkbox"/> US Gal/h</td> <td></td> <td></td> </tr> <tr> <td><input type="checkbox"/> lb/min</td> <td><input type="checkbox"/> ACFS</td> <td></td> <td></td> </tr> <tr> <td><input type="checkbox"/> lb/h</td> <td><input type="checkbox"/> ACFM</td> <td></td> <td></td> </tr> <tr> <td></td> <td><input type="checkbox"/> ACFH</td> <td></td> <td></td> </tr> </tbody> </table> </td> <td style="border: none;"></td> </tr> </table> <p style="text-align: center;">Default: Volume; m³/h</p> <table style="width: 100%;"> <tr> <td style="width: 50%; vertical-align: top;"> <p>Output Characteristic</p> <p><input type="checkbox"/> linear (HART only)</p> </td> <td style="width: 50%; vertical-align: top;"> <p><input type="checkbox"/> square root (default)</p> </td> </tr> </table> <table style="width: 100%;"> <tr> <td style="width: 50%; vertical-align: top;"> <p>Operation Point</p> <p>Max Pressure _____ [pressure eng. unit]</p> <p>Max Flow _____ [flow unit]</p> <p>LRV _____ [pressure eng. unit] (Lower Range Value (HART only))</p> </td> <td style="width: 50%; vertical-align: top;"> <p>Max Pressure _____ [pressure eng. unit]</p> <p>Max Flow _____ [flow unit]</p> <p>LRV _____ [flow unit] (Lower Range Value (HART only))</p> </td> </tr> </table> <p>Low flow cut off</p> <p>Value: _____ [%] (default = 5%)</p> <p>Display Information</p> <table style="width: 100%;"> <tr> <td style="width: 50%;"> <p>1st Value Display Measured Value (PV)</p> </td> <td style="width: 50%;"> <p>2nd Value Display¹⁾ <input type="checkbox"/> none (default) <input type="checkbox"/> Pressure <input type="checkbox"/> Totalizer 1 <input type="checkbox"/> Totalizer 2 <input type="checkbox"/> Current [mA] <input type="checkbox"/> Main Measured Value (%) <input type="checkbox"/> Temperature</p> </td> </tr> </table> <p>Damping</p> <p>Damping: _____ sec (default 2 sec)</p> <p>¹⁾ Depending on sensor and communication variant</p>	<input type="checkbox"/> Mass	<input type="checkbox"/> Volume	<input type="checkbox"/> Percent		<table border="1" style="width: 100%; border-collapse: collapse;"> <thead> <tr> <th style="width: 25%;">Operation Condition</th> <th style="width: 25%;">Norm Condition</th> <th style="width: 25%;">Standard Condition</th> <th style="width: 25%;"></th> </tr> </thead> <tbody> <tr> <td><input type="checkbox"/> kg/s</td> <td><input type="checkbox"/> m³/s</td> <td><input type="checkbox"/> Nm³/s</td> <td><input type="checkbox"/> Sm³/s</td> </tr> <tr> <td><input type="checkbox"/> kg/min</td> <td><input type="checkbox"/> m³/min</td> <td><input type="checkbox"/> Nm³/min</td> <td><input type="checkbox"/> Sm³/min</td> </tr> <tr> <td><input type="checkbox"/> kg/h</td> <td><input type="checkbox"/> m³/h</td> <td><input type="checkbox"/> Nm³/h</td> <td><input type="checkbox"/> Sm³/h</td> </tr> <tr> <td><input type="checkbox"/> t/s</td> <td><input type="checkbox"/> l/s</td> <td><input type="checkbox"/> Nm³/d</td> <td><input type="checkbox"/> Sm³/d</td> </tr> <tr> <td><input type="checkbox"/> t/min</td> <td><input type="checkbox"/> l/min</td> <td></td> <td><input type="checkbox"/> SCFS</td> </tr> <tr> <td><input type="checkbox"/> t/h</td> <td><input type="checkbox"/> l/h</td> <td></td> <td><input type="checkbox"/> SCFM</td> </tr> <tr> <td><input type="checkbox"/> oz/s</td> <td><input type="checkbox"/> US Gal/s</td> <td></td> <td><input type="checkbox"/> SCFH</td> </tr> <tr> <td><input type="checkbox"/> oz/min</td> <td><input type="checkbox"/> US Gal/min</td> <td></td> <td><input type="checkbox"/> SCFD</td> </tr> <tr> <td><input type="checkbox"/> lb/s</td> <td><input type="checkbox"/> US Gal/h</td> <td></td> <td></td> </tr> <tr> <td><input type="checkbox"/> lb/min</td> <td><input type="checkbox"/> ACFS</td> <td></td> <td></td> </tr> <tr> <td><input type="checkbox"/> lb/h</td> <td><input type="checkbox"/> ACFM</td> <td></td> <td></td> </tr> <tr> <td></td> <td><input type="checkbox"/> ACFH</td> <td></td> <td></td> </tr> </tbody> </table>	Operation Condition	Norm Condition	Standard Condition		<input type="checkbox"/> kg/s	<input type="checkbox"/> m ³ /s	<input type="checkbox"/> Nm ³ /s	<input type="checkbox"/> Sm ³ /s	<input type="checkbox"/> kg/min	<input type="checkbox"/> m ³ /min	<input type="checkbox"/> Nm ³ /min	<input type="checkbox"/> Sm ³ /min	<input type="checkbox"/> kg/h	<input type="checkbox"/> m ³ /h	<input type="checkbox"/> Nm ³ /h	<input type="checkbox"/> Sm ³ /h	<input type="checkbox"/> t/s	<input type="checkbox"/> l/s	<input type="checkbox"/> Nm ³ /d	<input type="checkbox"/> Sm ³ /d	<input type="checkbox"/> t/min	<input type="checkbox"/> l/min		<input type="checkbox"/> SCFS	<input type="checkbox"/> t/h	<input type="checkbox"/> l/h		<input type="checkbox"/> SCFM	<input type="checkbox"/> oz/s	<input type="checkbox"/> US Gal/s		<input type="checkbox"/> SCFH	<input type="checkbox"/> oz/min	<input type="checkbox"/> US Gal/min		<input type="checkbox"/> SCFD	<input type="checkbox"/> lb/s	<input type="checkbox"/> US Gal/h			<input type="checkbox"/> lb/min	<input type="checkbox"/> ACFS			<input type="checkbox"/> lb/h	<input type="checkbox"/> ACFM				<input type="checkbox"/> ACFH				<p>Output Characteristic</p> <p><input type="checkbox"/> linear (HART only)</p>	<p><input type="checkbox"/> square root (default)</p>	<p>Operation Point</p> <p>Max Pressure _____ [pressure eng. unit]</p> <p>Max Flow _____ [flow unit]</p> <p>LRV _____ [pressure eng. unit] (Lower Range Value (HART only))</p>	<p>Max Pressure _____ [pressure eng. unit]</p> <p>Max Flow _____ [flow unit]</p> <p>LRV _____ [flow unit] (Lower Range Value (HART only))</p>	<p>1st Value Display Measured Value (PV)</p>	<p>2nd Value Display¹⁾ <input type="checkbox"/> none (default) <input type="checkbox"/> Pressure <input type="checkbox"/> Totalizer 1 <input type="checkbox"/> Totalizer 2 <input type="checkbox"/> Current [mA] <input type="checkbox"/> Main Measured Value (%) <input type="checkbox"/> Temperature</p>
<input type="checkbox"/> Mass	<input type="checkbox"/> Volume	<input type="checkbox"/> Percent																																																															
	<table border="1" style="width: 100%; border-collapse: collapse;"> <thead> <tr> <th style="width: 25%;">Operation Condition</th> <th style="width: 25%;">Norm Condition</th> <th style="width: 25%;">Standard Condition</th> <th style="width: 25%;"></th> </tr> </thead> <tbody> <tr> <td><input type="checkbox"/> kg/s</td> <td><input type="checkbox"/> m³/s</td> <td><input type="checkbox"/> Nm³/s</td> <td><input type="checkbox"/> Sm³/s</td> </tr> <tr> <td><input type="checkbox"/> kg/min</td> <td><input type="checkbox"/> m³/min</td> <td><input type="checkbox"/> Nm³/min</td> <td><input type="checkbox"/> Sm³/min</td> </tr> <tr> <td><input type="checkbox"/> kg/h</td> <td><input type="checkbox"/> m³/h</td> <td><input type="checkbox"/> Nm³/h</td> <td><input type="checkbox"/> Sm³/h</td> </tr> <tr> <td><input type="checkbox"/> t/s</td> <td><input type="checkbox"/> l/s</td> <td><input type="checkbox"/> Nm³/d</td> <td><input type="checkbox"/> Sm³/d</td> </tr> <tr> <td><input type="checkbox"/> t/min</td> <td><input type="checkbox"/> l/min</td> <td></td> <td><input type="checkbox"/> SCFS</td> </tr> <tr> <td><input type="checkbox"/> t/h</td> <td><input type="checkbox"/> l/h</td> <td></td> <td><input type="checkbox"/> SCFM</td> </tr> <tr> <td><input type="checkbox"/> oz/s</td> <td><input type="checkbox"/> US Gal/s</td> <td></td> <td><input type="checkbox"/> SCFH</td> </tr> <tr> <td><input type="checkbox"/> oz/min</td> <td><input type="checkbox"/> US Gal/min</td> <td></td> <td><input type="checkbox"/> SCFD</td> </tr> <tr> <td><input type="checkbox"/> lb/s</td> <td><input type="checkbox"/> US Gal/h</td> <td></td> <td></td> </tr> <tr> <td><input type="checkbox"/> lb/min</td> <td><input type="checkbox"/> ACFS</td> <td></td> <td></td> </tr> <tr> <td><input type="checkbox"/> lb/h</td> <td><input type="checkbox"/> ACFM</td> <td></td> <td></td> </tr> <tr> <td></td> <td><input type="checkbox"/> ACFH</td> <td></td> <td></td> </tr> </tbody> </table>	Operation Condition	Norm Condition	Standard Condition		<input type="checkbox"/> kg/s	<input type="checkbox"/> m ³ /s	<input type="checkbox"/> Nm ³ /s	<input type="checkbox"/> Sm ³ /s	<input type="checkbox"/> kg/min	<input type="checkbox"/> m ³ /min	<input type="checkbox"/> Nm ³ /min	<input type="checkbox"/> Sm ³ /min	<input type="checkbox"/> kg/h	<input type="checkbox"/> m ³ /h	<input type="checkbox"/> Nm ³ /h	<input type="checkbox"/> Sm ³ /h	<input type="checkbox"/> t/s	<input type="checkbox"/> l/s	<input type="checkbox"/> Nm ³ /d	<input type="checkbox"/> Sm ³ /d	<input type="checkbox"/> t/min	<input type="checkbox"/> l/min		<input type="checkbox"/> SCFS	<input type="checkbox"/> t/h	<input type="checkbox"/> l/h		<input type="checkbox"/> SCFM	<input type="checkbox"/> oz/s	<input type="checkbox"/> US Gal/s		<input type="checkbox"/> SCFH	<input type="checkbox"/> oz/min	<input type="checkbox"/> US Gal/min		<input type="checkbox"/> SCFD	<input type="checkbox"/> lb/s	<input type="checkbox"/> US Gal/h			<input type="checkbox"/> lb/min	<input type="checkbox"/> ACFS			<input type="checkbox"/> lb/h	<input type="checkbox"/> ACFM				<input type="checkbox"/> ACFH														
Operation Condition	Norm Condition	Standard Condition																																																															
<input type="checkbox"/> kg/s	<input type="checkbox"/> m ³ /s	<input type="checkbox"/> Nm ³ /s	<input type="checkbox"/> Sm ³ /s																																																														
<input type="checkbox"/> kg/min	<input type="checkbox"/> m ³ /min	<input type="checkbox"/> Nm ³ /min	<input type="checkbox"/> Sm ³ /min																																																														
<input type="checkbox"/> kg/h	<input type="checkbox"/> m ³ /h	<input type="checkbox"/> Nm ³ /h	<input type="checkbox"/> Sm ³ /h																																																														
<input type="checkbox"/> t/s	<input type="checkbox"/> l/s	<input type="checkbox"/> Nm ³ /d	<input type="checkbox"/> Sm ³ /d																																																														
<input type="checkbox"/> t/min	<input type="checkbox"/> l/min		<input type="checkbox"/> SCFS																																																														
<input type="checkbox"/> t/h	<input type="checkbox"/> l/h		<input type="checkbox"/> SCFM																																																														
<input type="checkbox"/> oz/s	<input type="checkbox"/> US Gal/s		<input type="checkbox"/> SCFH																																																														
<input type="checkbox"/> oz/min	<input type="checkbox"/> US Gal/min		<input type="checkbox"/> SCFD																																																														
<input type="checkbox"/> lb/s	<input type="checkbox"/> US Gal/h																																																																
<input type="checkbox"/> lb/min	<input type="checkbox"/> ACFS																																																																
<input type="checkbox"/> lb/h	<input type="checkbox"/> ACFM																																																																
	<input type="checkbox"/> ACFH																																																																
<p>Output Characteristic</p> <p><input type="checkbox"/> linear (HART only)</p>	<p><input type="checkbox"/> square root (default)</p>																																																																
<p>Operation Point</p> <p>Max Pressure _____ [pressure eng. unit]</p> <p>Max Flow _____ [flow unit]</p> <p>LRV _____ [pressure eng. unit] (Lower Range Value (HART only))</p>	<p>Max Pressure _____ [pressure eng. unit]</p> <p>Max Flow _____ [flow unit]</p> <p>LRV _____ [flow unit] (Lower Range Value (HART only))</p>																																																																
<p>1st Value Display Measured Value (PV)</p>	<p>2nd Value Display¹⁾ <input type="checkbox"/> none (default) <input type="checkbox"/> Pressure <input type="checkbox"/> Totalizer 1 <input type="checkbox"/> Totalizer 2 <input type="checkbox"/> Current [mA] <input type="checkbox"/> Main Measured Value (%) <input type="checkbox"/> Temperature</p>																																																																

Instruments International

Endress+Hauser
Instruments International AG
Kaegenstrasse 2
4153 Reinach
Switzerland

Tel. +41 61 715 81 00
Fax +41 61 715 25 00
www.endress.com
info@ii.endress.com

Endress+Hauser 
People for Process Automation

