

Technical Information

RID16

8-channel field indicator
with FOUNDATION Fieldbus™ or PROFIBUS® PA
protocol



Field indicator for easy integration into
existing fieldbus systems



Application

- Field indicator with 8 input channels and FOUNDATION Fieldbus™ or PROFIBUS® PA protocol for displaying process values and calculated values
- Onsite display of process parameters in fieldbus systems

Your benefits

- Bright, backlit LC indicator with bar graph, diagnostic symbols and plain text field
- Listener mode for up to 8 analog channels or digital statuses
- 8-channel indicator via function block interconnection in the case of FOUNDATION Fieldbus™
- Safe operation in hazardous areas thanks to international approvals such as
 - FM IS, NI
 - CSA IS, NI
 - ATEX Ex ia, Ex nAfor intrinsically safe installation in zone 1 and zone 2
- Optional aluminum housing for Ex applications

Function and system design

Measuring principle

Backlit display for up to 8 process values or calculated values of the fieldbus users connected to the fieldbus system via listener mode, or also via function block interconnection in the case of FOUNDATION Fieldbus™.

Measuring system

Endress+Hauser has a wide range of innovative products which can be used with the FOUNDATION Fieldbus™ and PROFIBUS® PA protocol. Together with the sensors and transmitters, the indicators form a complete measuring point for various applications in the industrial sector.

Device architecture

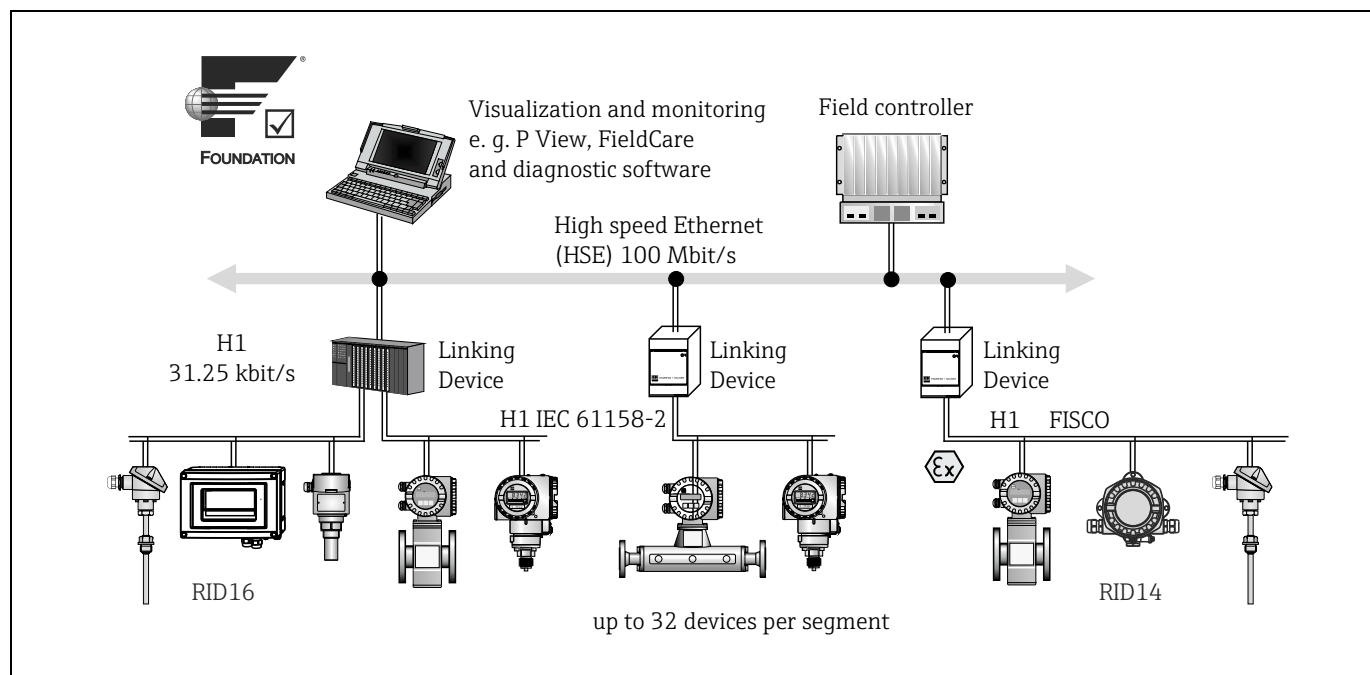

System integration via FOUNDATION Fieldbus™

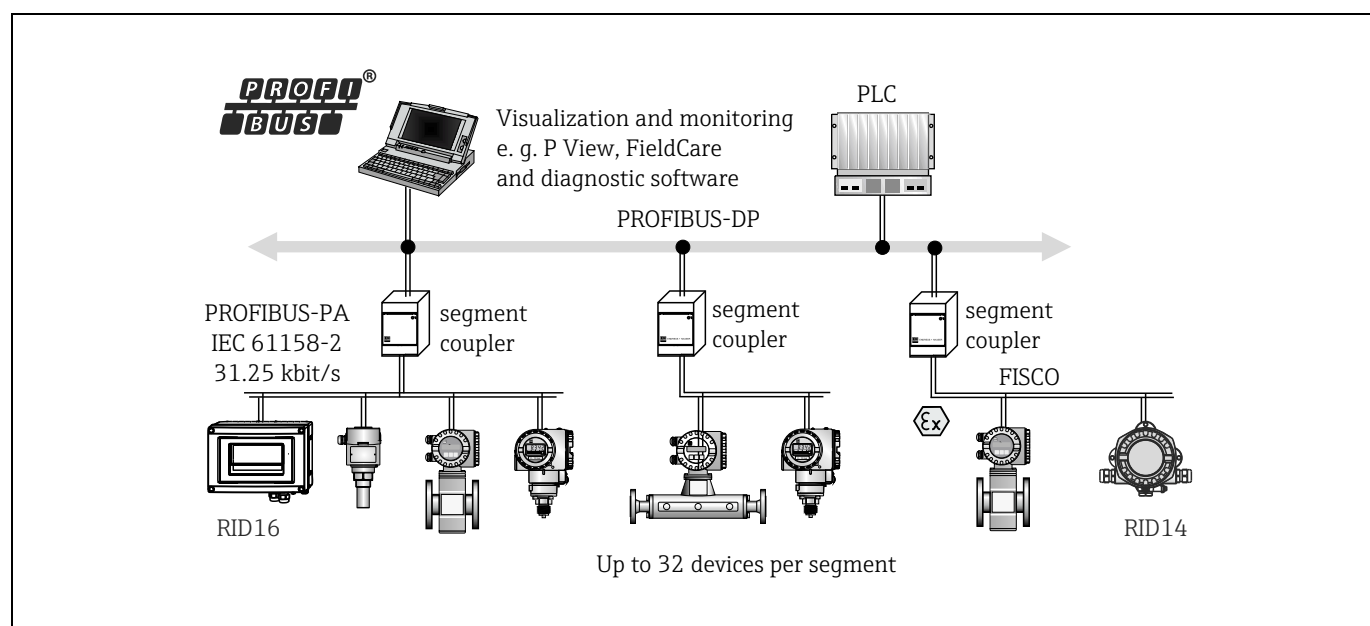

System integration via PROFIBUS® PA

The 8-channel indicator displays the measured values, calculated values and status information of the fieldbus users in a fieldbus network. In the listener mode, the device listens to the set fieldbus addresses and displays their specific values. Furthermore, values available on the bus can be also displayed via function block interconnection in the case of a FOUNDATION Fieldbus™ indicator. Individual settings can be made for each channel. Analog values from the bus user are displayed as a five-digit number while digital values are displayed as plain text (ON/OFF, OPEN/CLOSE, numerical values). The process value status is indicated by icons or as plain text on the measured value display. Plain text display makes it possible to display alphanumeric character combinations, such as the TAG. For trend analysis, in addition to indicating measured values the indicator also has a bar graph, with indicators for overranging and underranging, which can be scaled independently of the display value. The device is powered by the fieldbus and can be used in hazardous areas up to temperature class T6.

Communication and data processing

Breakdown information

- Status message as per the fieldbus specification.

Switch-on delay

- 8 s

FOUNDATION Fieldbus™

- FOUNDATION Fieldbus™ H1, IEC 61158-2
- FDE (Fault Disconnection Electronic) = 0 mA
- Data transmission rate: supported baud rate = 31.25 kBit/s
- Signal coding = Manchester II
- LAS (link active scheduler), LM (link master) function is supported:
Thus, the indicator unit can assume the function of a link active scheduler (LAS) if the current link master (LM) is no longer available. The device is supplied as a BASIC device. To use the device as an LAS, this must be defined in the distributed control system and activated by downloading the configuration to the device.
- In accordance with IEC 60079-27, FISCO/FNICO

PROFIBUS® PA

- PROFIBUS® PA in accordance with EN 50170 Volume 2, IEC 61158-2 (MBP)
- FDE (Fault Disconnection Electronic) = 0 mA
- Data transmission rate: supported baud rate = 31.25 kBit/s
- Signal coding = Manchester II
- Connection data in accordance with IEC 60079-11 FISCO, Entity

Protocol-specific data

FOUNDATION Fieldbus™	
Basic data	
Device type	10CF (hex)
Device revision	01 (hex)
Node Address	Default: 247
ITK version	5.2.0
ITK Certification Driver No.	IT064000
Link Master-capable (LAS)	Yes
Link Master / Basic Device selectable	Yes; factory setting: Basic Device
Number of VCRs	58
Number of Link Objects in VFD	64
Virtual communication relationships (VCRs)	
Permanent Entries	58
Client VCRs	0
Server VCRs	5
Source VCRs	8
Sink VCRs	0

Subscriber VCRs	35			
Publisher VCRs	10			
Link settings				
Slot time	4			
Min. inter PDU delay	12			
Max. response delay	40			
Blocks				
Block description	Block index	Permanent	Block execution time	Block class
Resource	400	YES		Extended
Display Transducer	500	YES		Manufacturer-specific
Advanced Diagnostic	600	YES		Manufacturer-specific
PID	700	NO	100 ms	Standard
Input Selector 1	800	NO	35 ms	Standard
Input Selector 2	900	NO	35 ms	Standard
Arithmetic	1000	NO	50 ms	Standard
Integrator	1100	NO	60 ms	Standard
Brief description of the blocks				
Resource Block:	The Resource Block contains all the data that clearly identify and characterize the device. It is like an electronic device nameplate. In addition to parameters that are needed to operate the device on the fieldbus, the Resource Block also makes other information available, such as the order code, device ID, software revision, order ID etc.			
Display Transducer:	The parameters of the "Display" Transducer Block allow the configuration of the display.			
Advanced Diagnostic:	All the parameters for automatic monitoring and diagnosis are grouped together in this Transducer Block.			
PID:	This function block contains input channel processing, proportional integral-differential control (PID) and analog output channel processing. The following can be implemented: basic controls, feedforward control, cascade control and cascade control with limiting.			
Input Selector (ISEL):	The block for selecting a signal (Input Selector Block - ISEL) allows the user to choose up to four inputs and generates an output based on the configured action.			
Integrator (INT):	The Integrator Block integrates one or two variables over time. The Block compares the integrated or totalized value to limit values and generates a discrete output signal if the limit value is reached. It can be selected from six integration types.			
Arithmetic (ARITH):	The Arithmetic function block permits standard computing operations and compensations. It supports the addition, subtraction, multiplication and division of values. Furthermore, mean values are calculated, and flow values are compensated (linear, quadratic compensation), in this block.			

PROFIBUS® PA	
Basic data	
Indicator for PROFIBUS PA, can be used in conjunction with PROFILE 2 and PROFILE 3 (3.0, 3.01 and 3.02) devices	
Device master files (GSD)	How to acquire device master files (GSD) and device drivers: <ul style="list-style-type: none"> FieldCare/DTM: www.endress.com → Select country → Solutions → Field Network Engineering → Fieldbus device integration → PROFIBUS → PROFIBUS® GSD files and certificates
Write protection	Write protection enabled by hardware setting (DIP switch)

Power supply

Electrical connection

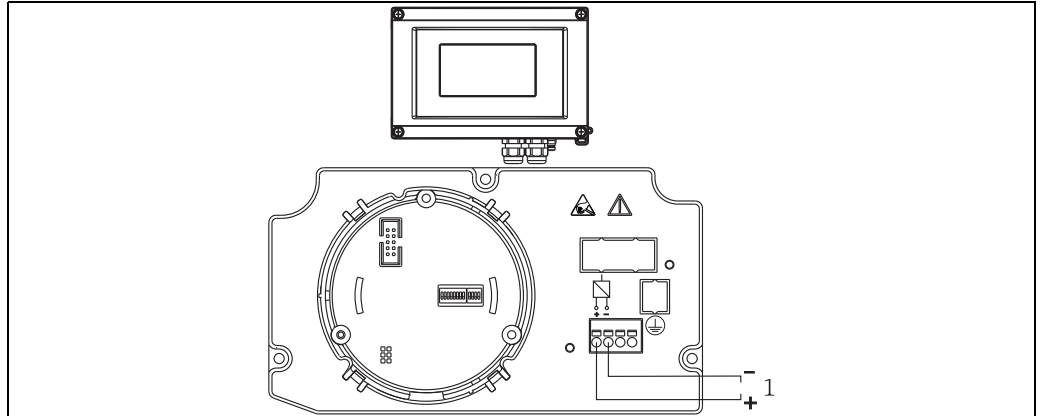

Terminal assignment of the field indicator

1 FOUNDATION Fieldbus™ or PROFIBUS® PA

A0021528

Supply voltage Voltage is supplied via the fieldbus.
 $U = 9$ to 32 V DC, polarity-independent (max. voltage $U_b = 35$ V).

Mains voltage filter 50/60 Hz

Current consumption ≤ 11 mA

Cable entry The following cable entries are available:

- Thread NPT1/2
- Thread M20
- Thread G1/2
- 2x gland NPT1/2 + 1x dummy plug
- 2x gland M20 + 1x dummy plug

Installation

Installation instructions

Mounting location

Wall or pipe mounting (see 'Accessories')

Orientation

No restrictions, the orientation depends on the readability of the display.

Environment

Ambient temperature limits	-40 to +80 °C (-40 to 176 °F) The display can react slowly at temperatures < -20 °C (-4 °F). The readability of the display is no longer guaranteed at temperatures < -30 °C (-22 °F).																						
Storage temperature	-40 to +80 °C (-40 to 176 °F)																						
Altitude	Up to 4000 m (13100 ft.) above mean sea level in accordance with IEC 61010-1, CSA 1010.1-92																						
Climate class	According to IEC 60654-1, Class C																						
Humidity	<ul style="list-style-type: none"> ■ Condensation permitted as per IEC 60 068-2-33 ■ Max. rel. humidity: 95% as per IEC 60068-2-30 																						
Degree of protection	IP67. NEMA 4X.																						
Shock and vibration resistance	10 to 2000 Hz for 5g as per IEC 60 068-2-6																						
Electromagnetic compatibility (EMC)	<p>CE EMC conformity</p> <p>The device complies with all the requirements of IEC 61326-1:2006 and NAMUR NE21:2007.</p> <p>This recommendation is a consistent determination as to whether the devices used in laboratories and in distributed control systems are immune to interference, thus increasing their functional safety.</p> <table border="1" style="width: 100%; border-collapse: collapse;"> <tbody> <tr> <td style="width: 25%;">ESD (electrostatic discharge)</td> <td style="width: 25%;">IEC 61000-4-2</td> <td style="width: 25%;">6 kV cont., 8 kV air</td> <td style="width: 25%;"></td> </tr> <tr> <td>Electromagnetic fields</td> <td>IEC 61000-4-3</td> <td>0.08 to 4 GHz</td> <td>10 V/m</td> </tr> <tr> <td>Burst (fast transients)</td> <td>IEC 61000-4-4</td> <td>1 kV</td> <td></td> </tr> <tr> <td>Surge</td> <td>IEC 61000-4-5</td> <td>1 kV asym.</td> <td></td> </tr> <tr> <td>Conducted RF</td> <td>IEC 61000-4-6</td> <td>0.01 to 80 MHz</td> <td>10 V</td> </tr> </tbody> </table>			ESD (electrostatic discharge)	IEC 61000-4-2	6 kV cont., 8 kV air		Electromagnetic fields	IEC 61000-4-3	0.08 to 4 GHz	10 V/m	Burst (fast transients)	IEC 61000-4-4	1 kV		Surge	IEC 61000-4-5	1 kV asym.		Conducted RF	IEC 61000-4-6	0.01 to 80 MHz	10 V
ESD (electrostatic discharge)	IEC 61000-4-2	6 kV cont., 8 kV air																					
Electromagnetic fields	IEC 61000-4-3	0.08 to 4 GHz	10 V/m																				
Burst (fast transients)	IEC 61000-4-4	1 kV																					
Surge	IEC 61000-4-5	1 kV asym.																					
Conducted RF	IEC 61000-4-6	0.01 to 80 MHz	10 V																				
Measuring category	Measuring category II as per IEC 61010-1. The measuring category is provided for measuring on power circuits that are directly connected electrically with the low-voltage network.																						
Degree of contamination	Pollution degree 2 as per IEC 61010-1.																						

Mechanical construction

Design, dimensions

Die-cast aluminum housing for general applications, or optional stainless steel housing

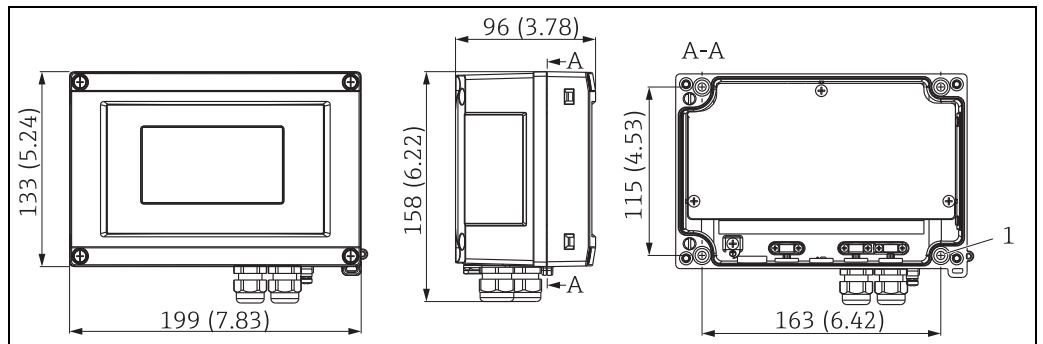

Dimensions of the field indicator; dimensions in mm (in)

1: Bore for mounting directly on the wall or on optional mounting plate with 4 screws $\varnothing 5$ mm (0.2")

Weight

- Plastic housing: approx. 500 g (1.1 lb)
- Aluminum housing: approx. 1.7 kg (3.75 lb)

Material

Housing	Nameplate
Fiber-glass reinforced plastic PBT-GF30	Laser inscription
Aluminum AlSi12 (optional)	Laser-writable film, polyester

Terminals

Screw terminals for cables up to max. 2.5 mm² (14 AWG) plus ferrule

Human interface

Display elements

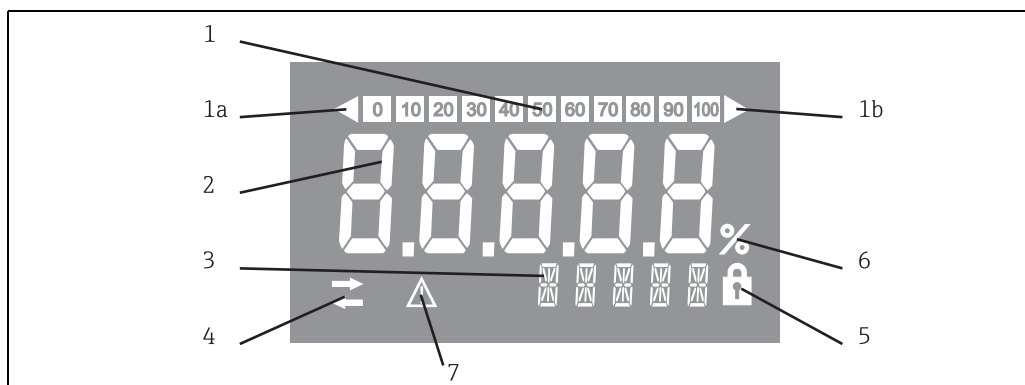

LC display of the field indicator

Item 1: bar graph display in increments of 10% with indicators for underranging (item 1a) and overranging (item 1b)

Item 2: measured value display, digit height 26 mm (1.02"), status indication "Bad measured value status"

Item 3: 14-segment display for units and messages

Item 4: 'Communication' symbol

Item 5: 'Parameters cannot be modified' symbol

Item 6: '%' unit

Item 7: 'Uncertain measured value status' symbol

- Display range
-9999 to +99999

Configuration

FOUNDATION Fieldbus™

The configuration of FOUNDATION Fieldbus™ functions and of device-specific parameters is performed via fieldbus communication. Special configuration systems provided by various manufacturers are available for this purpose.

Distributed control systems	Asset management systems
Endress+Hauser ControlCare	National Instruments NI-Configurator (≥ 3.1.1)
Emerson DeltaV	Emerson AMS and Handheld FC375
Rockwell Control Logix/FFLD	-
Honeywell PKS Experion	-
Yokogawa Centum CS3000	-

PROFIBUS® PA

The parameters can either be configured remotely via the DTM and configuration software or locally via DIP switches.

Certificates and approvals

CE mark	The device meets the legal requirements of the EC directives. Endress+Hauser confirms that the device has been successfully tested by applying the CE mark.
Ex-approval	Information about currently available Ex versions (ATEX, FM, CSA, etc.) can be supplied by your E+H Sales Center on request. All explosion protection data are given in a separate documentation which is available upon request.
Other standards and guidelines	<ul style="list-style-type: none">■ IEC 60529: Degrees of protection provided by enclosures (IP code)■ IEC 61010-1: Safety requirements for electrical equipment for measurement, control and laboratory use■ IEC 61326 series: Electromagnetic compatibility (EMC requirements)■ NAMUR: International user association of automation technology in process industries (www.namur.de)
Equipment safety UL	Recognized component to UL61010-1
CSA GP	CSA General Purpose

Ordering information

Detailed ordering information is available from the following sources:

- In the Product Configurator on the Endress+Hauser website: www.endress.com → Select country → Instruments → Select device → Product page function: Configure this product
- From your Endress+Hauser Sales Center: www.endress.com/worldwide



Product Configurator - the tool for individual product configuration

- Up-to-the-minute configuration data
- Depending on the device: Direct input of measuring point-specific information such as measuring range or operating language
- Automatic verification of exclusion criteria
- Automatic creation of the order code and its breakdown in PDF or Excel output format
- Ability to order directly in the Endress+Hauser Online Shop

Accessories

Various accessories are available for the device, and these can be ordered with the device or at a later stage from Endress+Hauser. Detailed information on the order code in question is available from your local Endress+Hauser Sales Center or on the product page of the Endress+Hauser website: www.endress.com.

Device-specific accessories

Designation	Type
Pipe mounting kit	with plastic mounting plate (for pipes Ø1-5 inch)
Weather protection cover	<p>Dimensions in mm (in)</p>

Communication-specific accessories

Designation	Type
Fieldbus connector	
FOUNDATION Fieldbus™	<ul style="list-style-type: none"> ■ M20 → 7/8"
PROFIBUS® PA	<ul style="list-style-type: none"> ■ NPT 1/2" → M12 ■ M20 → M12 ■ M20 → 7/8"
Interface cable	Commubox FXA291 incl. FieldCare Device Setup + DTM Library

Documentation

- Overview brochure: System Components and Data Managers - Solutions for a Complete Measuring Point: FA00016K/09
- Operating Instructions 'Field indicator RID16 with FOUNDATION Fieldbus™ protocol': BA00284R/09
- Operating Instructions 'Field indicator RID16 with PROFIBUS® PA protocol': BA01268K/09
- ATEX Safety instructions:
 - ATEX II2G Ex ia IIC: XA00099R/09

www.addresses.endress.com
