



Level



Pressure



Flow



Temperature



Liquid
Analysis



Registration



Systems
Components



Services



Solutions

Brief Operating Instructions

Proline Promag 10D

Electromagnetic flow measuring system

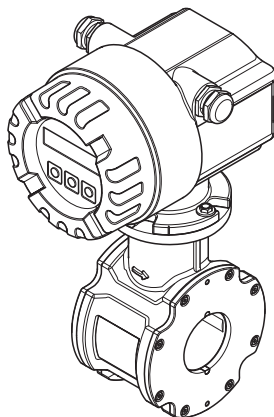

These Brief Operating Instructions are **not** intended to replace the Operating Instructions provided in the scope of supply. Detailed information is provided in the Operating Instructions and the additional documentation on the CD-ROM supplied.

The complete device documentation consists of:

- These Brief Operating Instructions
- Depending on the device version:
 - Operating Instructions and the Description of Device Functions
 - Approvals and safety certificates
 - Special safety instructions in accordance with the approvals for the device (e.g. explosion protection, pressure equipment directive etc.)
 - Additional device-specific information

Table of contents

1 Safety instructions	3
1.1 Designated use	3
1.2 Installation, commissioning and operation	3
1.3 Operational safety	3
1.4 Safety conventions	5
2 Installation	6
2.1 Installation conditions	6
2.2 Installing the sensor	10
2.3 Installing the transmitter housing	14
2.4 Post-installation check	16
3 Wiring	17
3.1 Connecting the various housing types	18
3.2 Connecting the remote version connecting cable	19
3.3 Potential equalization	21
3.4 Degree of protection	22
3.5 Post-connection check	22
4 Commissioning	23
4.1 Switching on the measuring device	23
4.2 Operation	24
4.3 Navigating within the function matrix	25
4.4 Device functions to be configured during commissioning	26
4.5 Troubleshooting	27

1 Safety instructions

1.1 Designated use

- The measuring device is to be used only for measuring the flow of conductive liquids in closed pipes. Most liquids can be measured as of a minimum conductivity of 50 $\mu\text{S}/\text{cm}$.
- Any use other than that described here compromises the safety of persons and the entire measuring system and is, therefore, not permitted.
- The manufacturer is not liable for damage caused by improper or non-designated use.

1.2 Installation, commissioning and operation

- The measuring device must only be installed, connected, commissioned and maintained by qualified and authorized specialists (e.g. electrical technicians) in full compliance with the instructions in these Brief Operating Instructions, the applicable norms, legal regulations and certificates (depending on the application).
- The specialists must have read and understood these Brief Operating Instructions and must follow the instructions they contain. If you are unclear on anything in these Brief Operating Instructions, you must read the Operating Instructions (on the CD-ROM). The Operating Instructions provide detailed information on the measuring device.
- The measuring device should only be installed in the pipe in a de-energized state free from outside loads or strain.
- The measuring device may only be modified if such work is expressly permitted in the Operating Instructions (on the CD-ROM).
- Repairs may only be performed if a genuine spare parts kit is available and this repair work is expressly permitted.
- If performing welding work on the piping, the welding unit may not be grounded by means of the measuring device.

1.3 Operational safety

- The measuring device is designed to meet state-of-the-art safety requirements, has been tested, and left the factory in a condition in which it is safe to operate. Relevant regulations and European standards have been observed.
- The manufacturer reserves the right to modify technical data without prior notice. Your Endress+Hauser distributor will supply you with current information and updates to these Operating Instructions.
- The information on the warning notices, nameplates and connection diagrams affixed to the device must be observed. These contain important data on the permitted operating conditions, the range of application of the device and information on the materials used.
- If the device is not used at atmospheric temperatures, compliance with the relevant marginal conditions as specified in the device documentation supplied (on CD-ROM) is mandatory.
- All parts of the device must be included in the potential equalization of the system.

- Cables, certified cable glands and certified dummy plugs must be suitable to withstand the prevailing operating conditions, such as the temperature range of the process. Housing apertures that are not used must be sealed with dummy plugs.
- The device should only be used for fluids to which all the wetted parts of the device are sufficiently resistant. With regard to special fluids, including fluids used for cleaning, Endress+Hauser will be happy to assist in clarifying the corrosion-resistant properties of wetted materials.
However, minor changes in temperature, concentration or in the degree of contamination in the process may result in variations in corrosion resistance.
For this reason, Endress+Hauser does not accept any responsibility with regard to the corrosion resistance of wetted materials in a specific application. The user is responsible for the choice of suitable wetted materials in the process.
- When hot fluid passes through the measuring tube, the surface temperature of the housing increases. In the case of the sensor, in particular, users should expect temperatures that can be close to the fluid temperature. If the temperature of the fluid is high, implement sufficient measures to prevent burning or scalding.
- Hazardous areas:
Measuring devices for use in hazardous areas are labeled accordingly on the nameplate. Relevant national regulations must be observed when operating the device in hazardous areas.
- Hygienic applications:
Measuring devices for hygienic applications have their own special labeling. Relevant national regulations must be observed when using these devices.
- Pressure devices:
Measuring devices for use in systems that need to be monitored are labeled accordingly on the nameplate. Relevant national regulations must be observed when using these devices. The documentation on the CD-ROM for pressure devices in systems that need to be monitored is an integral part of the entire device documentation. The installation regulations, connection data and safety instructions provided in the Ex documentation must be observed.
- Endress+Hauser will be happy to assist in clarifying any questions on approvals, their application and implementation.

1.4 Safety conventions



Warning!

"Warning" indicates an action or procedure which, if not performed correctly, can result in injury or a safety hazard. Comply strictly with the instructions and proceed with care.



Caution!

"Caution" indicates an action or procedure which, if not performed correctly, can result in incorrect operation or destruction of the device. Comply strictly with the instructions.



Note!

"Note" indicates an action or procedure which, if not performed correctly, can have an indirect effect on operation or trigger an unexpected response on the part of the device.

2 Installation

2.1 Installation conditions

2.1.1 Dimensions

For the dimensions of the measuring device, → see the associated Technical Information on the CD-ROM.

Mounting location

The sensor should preferably be installed in an ascending pipe. Ensure the sensor is an adequate distance ($\geq 2 \times \text{DN}$) away from the next pipe bend.



Note!

Entrained air or gas bubble formation in the measuring tube can result in an increase in measuring errors. For this reason, the following mounting locations should be **avoided**:

- Highest point of a pipeline. Risk of air accumulating!
- Directly upstream from a free pipe outlet in a vertical pipeline. Risk of pipe not filling correctly!

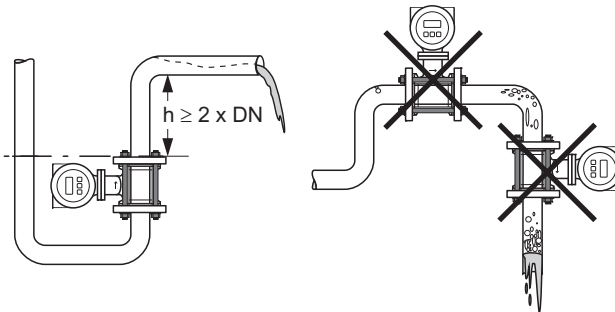

a0010747

Partially filled pipes

Partially filled pipes with gradients necessitate a drain-type configuration.

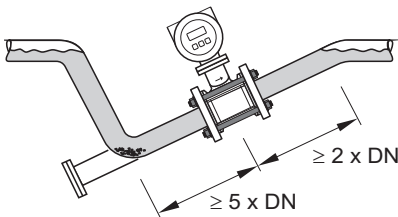

a0010749

Installation in a partially filled pipe

Installation with pumps

The sensor should only be installed on the pump pressure side.



Note!

- The sensor should **never** be installed on the pump suction side in order to avoid the risk of low pressure, and thus damage to the measuring tube.
- Pulsation dampers may be needed if the sensor is installed downstream from piston pumps, piston diaphragm pumps or hose pumps.

For information on the measuring tube's pressure tightness and the device's resistance to vibration and shock → see the related Technical Information on the CD-ROM.

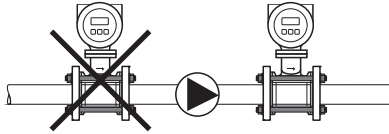

a0010748

Down pipes

Install a siphon or a vent valve downstream of the sensor in down pipes longer than 5 meters (16 ft). This precaution is to avoid low pressure and the consequent risk of damage to the measuring tube. This measure also prevents the system losing prime, which could cause air pockets. For information on the measuring tube's pressure tightness → see the related Technical Information on the CD-ROM.

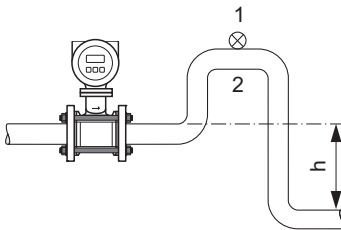

Measures for installation in a down pipe (h > 5 m/16 ft)

1. Vent valve
2. Siphon

a0010750

Orientation

Vertical orientation

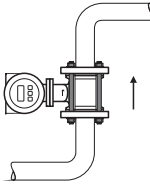

a0010709

Measures for installation in a down pipe ($h > 5 \text{ m}/16 \text{ ft}$)
 Vertical orientation is generally preferred. Vertical orientation helps avoid gas and air accumulations and deposits in the measuring tube.

Horizontal orientation

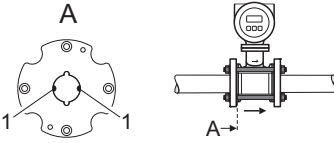

a0010710

The measuring electrode axis should be horizontal in the case of horizontal orientations. This prevents brief insulation of the two measuring electrodes by entrained air bubbles.

1 = Measuring electrodes for signal detection

Inlet and outlet run

If possible, install the sensor upstream from fittings such as valves, T-pieces, elbows, etc.

The following inlet and outlet runs must be observed in order to meet accuracy specifications:

- Inlet run $\geq 5 \times \text{DN}$
- Outlet run $\geq 2 \times \text{DN}$

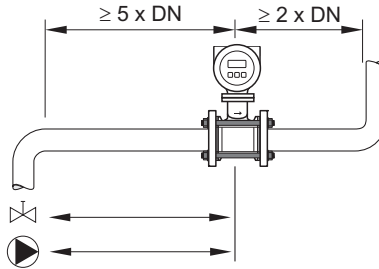

a0010751

2.1.2 Vibrations

Secure the piping and the sensor if vibration is severe.

 **Caution!**

If vibrations are too severe (>2 g/2 h per day; 10 to 100 Hz), we recommend the sensor and transmitter be mounted separately. For information on the permitted shock and vibration resistance → see the Technical Information on the CD-ROM.

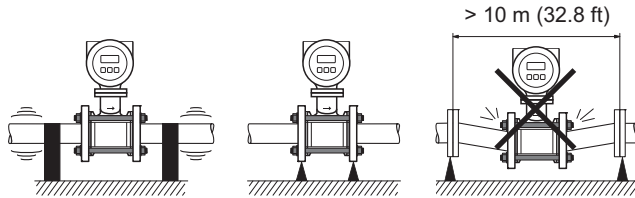

a0010752-ae

2.1.3 Length of connecting cable

Note the following when mounting the remote version:

- Fix cable run or lay in armored conduit.

 **Note!**

Cable movements can falsify the measuring signal especially in the case of low fluid conductivities.

- Route the cable well clear of electrical machines and switching elements.
- If necessary, establish potential equalization between the sensor and transmitter.
- The permitted length of the connection cable L_{max} (area shaded gray in the graphic) depends on the conductivity of the fluid. A minimum conductivity of 50 $\mu\text{S}/\text{cm}$ is needed for all fluids.

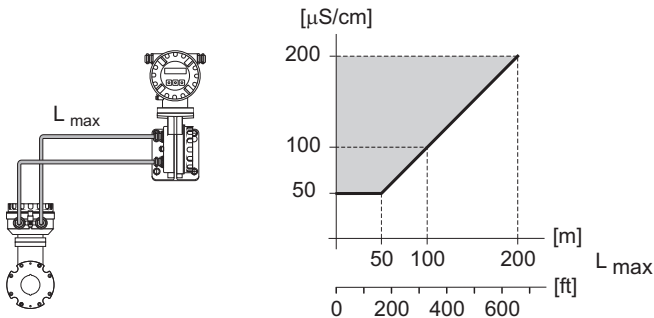

a0010754-ae

2.2 Installing the sensor

2.2.1 Mounting kit

The sensor is installed between the pipe flanges with a mounting kit. The device is centered using recesses on the sensor.



Note!

A mounting kit consisting of nuts (1), washers (2), mounting bolts (3) and seals (5) can be ordered separately. Centering sleeves (4) are provided with the device if they are required for the installation.

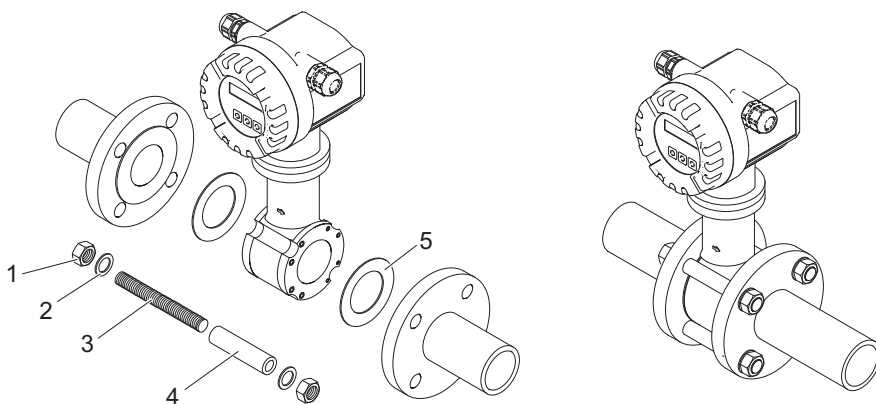

a0010714

Seals

When installing the sensor, make sure that the seals used do not project into the pipe cross-section.



Caution!

Risk of short circuit!

Do not use electrically conductive sealing compounds such as graphite! An electrically conductive layer could form on the inside of the measuring tube and short-circuit the measuring signal.





Note!

Use seals with a hardness rating of 70° Shore.

Arrangement of the mounting bolts and centering sleeves

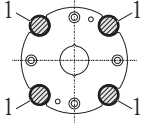
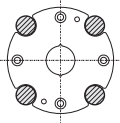
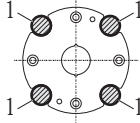
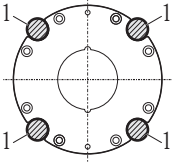
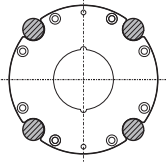
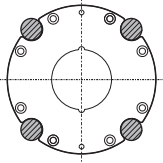
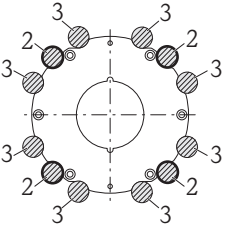
The device is centered using recesses on the sensor. The arrangement of the mounting bolts and the use of the centering sleeves supplied depend on the nominal diameter and pressure rating of the device.

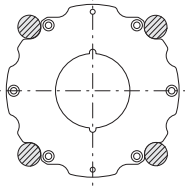
Pressure rating		
EN (DIN)	ANSI	JIS
DN 25 to 40 (1" to 1 1/2")		
 <small>A0010896</small>	 <small>A0010824</small>	 <small>A0010896</small>
DN 50 (2")		
 <small>A0010897</small>	 <small>A0010825</small>	 <small>A0010825</small>
DN 65		
 <small>A0012170</small>		 <small>A0012171</small>

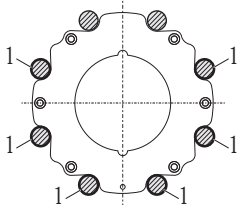
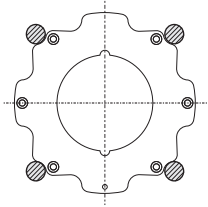
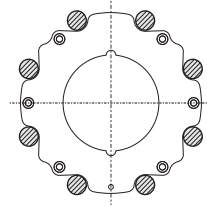
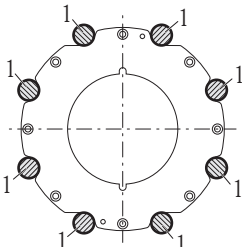
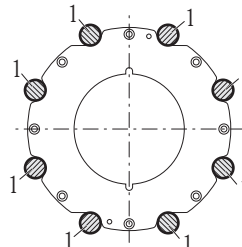
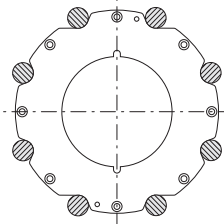
<p>DN 80 (3")</p>  <p style="text-align: right; font-size: small;">A0010898</p>	 <p style="text-align: right; font-size: small;">A0010827</p>	 <p style="text-align: right; font-size: small;">A0010826</p>
<p>DN 100 (4")</p>  <p style="text-align: right; font-size: small;">A0012168</p>	 <p style="text-align: right; font-size: small;">A0012168</p>	 <p style="text-align: right; font-size: small;">A0012169</p>
<p>1 = Mounting bolts with centering sleeves 2 = EN (DIN) flanges: 4-hole → with centering sleeves 3 = EN (DIN) flanges: 8-hole → without centering sleeves</p>		

Tightening torques

Please note the following:

- The tightening torques listed below are for lubricated threads only.
- Always tighten the screws uniformly and in diagonally opposite sequence.
- Overtightening the screws will deform the sealing faces or damage the seals.
- The tightening torques listed below apply only to pipes not subjected to tensile stress.

The tightening torques apply to situations where an EPDM soft material flat seal (e.g. 70 Shore) is used.

Tightening torques, mounting bolts and centering sleeves for EN (DIN) PN 16

Nominal diameter [mm]	Mounting bolts [mm]	Centering sleeve length [mm]	Tightening torque [Nm] with a process flange with a	
			smooth seal face	raised face
25	4 × M12 × 145	54	19	19
40	4 × M16 × 170	68	33	33
50	4 × M16 × 185	82	41	41
65 ¹⁾	4 × M16 × 200	92	44	44

Nominal diameter [mm]	Mounting bolts [mm]	Centering sleeve length [mm]	Tightening torque [Nm] with a process flange with a	
			smooth seal face	raised face
65 ²⁾	8 × M16 × 200	– ³⁾	29	29
80	8 × M16 × 225	116	36	36
100	8 × M16 × 260	147	40	40

¹⁾ EN (DIN) flanges: 4-hole → with centering sleeves
²⁾ EN (DIN) flanges: 8-hole → without centering sleeves
³⁾ A centering sleeve is not required. The device is centered directly via the sensor housing.

Tightening torques, mounting bolts and centering sleeves for JIS 10 K

Nominal diameter [mm]	Mounting bolts [mm]	Centering sleeve length [mm]	Tightening torque [Nm] with a process flange with a	
			smooth seal face	raised face
25	4 × M16 × 170	54	24	24
40	4 × M16 × 170	68	32	25
50	4 × M16 × 185	– *	38	30
65	4 × M16 × 200	– *	42	42
80	8 × M16 × 225	– *	36	28
100	8 × M16 × 260	– *	39	37

* A centering sleeve is not required. The device is centered directly via the sensor housing.

Tightening torques, mounting bolts and centering sleeves for ANSI Class 150

Nominal diameter [inch]	Mounting bolts [inch]	Centering sleeve length [inch]	Tightening torque [lbf · ft] with a process flange with a	
			smooth seal face	raised face
1"	4 × UNC 1/2" × 5.70"	– *	14	7
1 1/2"	4 × UNC 1/2" × 6.50"	– *	21	14
2"	4 × UNC 5/8" × 7.50"	– *	30	27
3"	4 × UNC 5/8" × 9.25"	– *	31	31
4"	8 × UNC 5/8" × 10.4"	5.79	28	28

* A centering sleeve is not required. The device is centered directly via the sensor housing.

2.3 Installing the transmitter housing

2.3.1 Turning the transmitter housing

Turning the aluminum field housing

☞ Caution!

- Raising the transmitter housing (Step c):
Raise the transmitter housing max. 10 mm (0.39 inch) above the securing screws
- Turning the transmitter housing (Step d):
Turn the transmitter housing max. 180° clockwise or counterclockwise

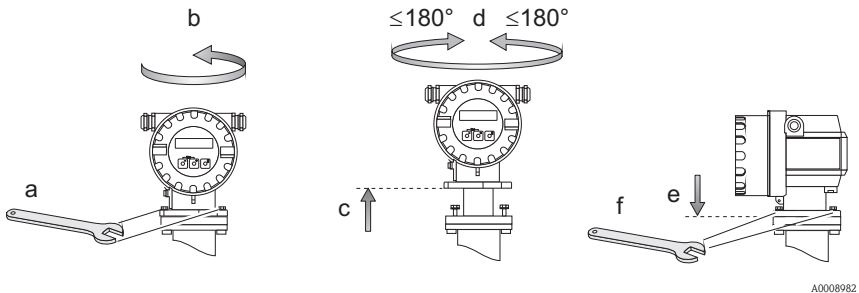

A0008982

2.3.2 Turning the onsite display

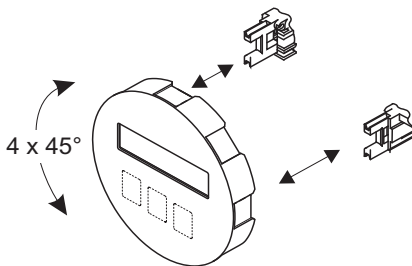

A0003237

- a. Unscrew cover of the electronics compartment from the transmitter housing.
- b. Remove the display module from the transmitter retaining rails.
- c. Turn the display to the desired position (max. 4 x 45° in each direction).
- d. Fit the display back onto the retaining rails.
- e. Screw the cover of the electronics compartment firmly back onto the transmitter housing.

2.3.3 Mounting the transmitter (remote version)

☞ Caution!

- The ambient temperature range -20 to $+60^{\circ}\text{C}$ (-4 to $+140^{\circ}\text{F}$) may not be exceeded at the mounting location. Avoid direct sunlight.
- If the device is mounted to a warm pipe, make sure that the housing temperature does not exceed $+60^{\circ}\text{C}$ ($+140^{\circ}\text{F}$), which is the maximum permissible temperature.

The transmitter can be mounted directly on a wall (A) or a pipe (B).

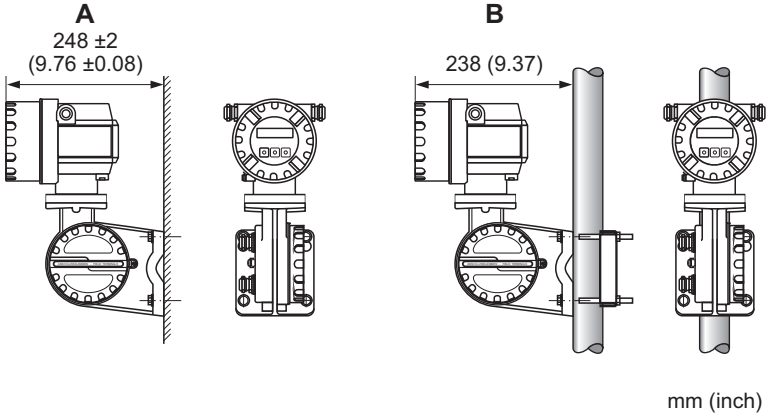

A0010753-ae

2.4 Post-installation check

- Is the measuring device damaged (visual inspection)?
- Does the device correspond to specifications at the measuring point, including process temperature and pressure, ambient temperature, minimum fluid conductivity, measuring range, etc.?
- Does the arrow on the sensor nameplate match the actual direction of flow through the pipe?
- Is the position of the measuring electrode plane correct?
- Is the position of the empty pipe detection electrode correct?
- Were all screws tightened to the specified torques when the sensor was installed?
- Were the correct seals used (type, material, installation)?
- Are the measuring point number and labeling correct (visual inspection)?
- Were the inlet and outlet runs respected?
- Is the measuring device protected against moisture and direct sunlight?
- Is the sensor adequately protected against vibration (attachment, support)?
Acceleration up to 2 g by analogy with IEC 600 68-2-8

3 Wiring



Warning!

Risk of electric shock! Components carry dangerous voltages.

- Never mount or wire the measuring device while it is connected to the power supply.
- Before connecting the power supply, check the safety equipment.
- Route the power supply and signal cables so they are securely seated.
- Seal the cable entries and covers tight.



Caution!

Risk of damaging the electronic components!

- Connect the power supply in accordance with the connection data on the nameplate.
- Connect the signal cable in accordance with the connection data in the Operating Instructions.

In addition, for the remote version:



Caution!

Risk of damaging the electronic components!

- Only connect sensors and transmitters with the same serial number.
- Observe the cable specifications of the connecting cable → Operating Instructions on the CD-ROM.



Note!

Install the connecting cable securely to prevent movement.

3.1 Connecting the various housing types

Wire the unit using the terminal assignment diagram inside the cover.

3.1.1 Compact version

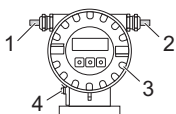

A0010755

Transmitter connection:

- 1 Signal cable
- 2 Power supply cable
- 3 Electronics compartment cover (connection diagram on the cover of the connection compartment)
- 4 Ground terminal for potential equalization

3.1.2 Remote version (transmitter)

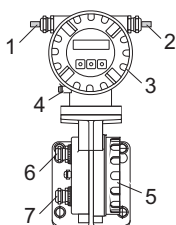

A0010757

Transmitter connection:

- 1 Signal cable
- 2 Power supply cable
- 3 Electronics compartment cover (connection diagram on the cover of the connection compartment)
- 4 Ground terminal for potential equalization

Connecting the connecting cable (Ø  19):

- 5 Connection compartment cover (connection diagram on the inside)
- 6 Coil current cable
- 7 Signal cable

3.1.3 Remote version (sensor)

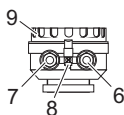

A0010758

Transmitter connection:

- 9 Connection compartment cover (connection diagram on the inside)

Connecting the connecting cable (Ø  19):

- 6 Coil current cable
- 7 Signal cable
- 8 Ground terminal for potential equalization

3.2 Connecting the remote version connecting cable

3.2.1 Connecting cable

Connecting cable termination

Terminate the signal and coil current cables as shown in the figure below (Detail A).
Fit the fine-wire cores with cable end ferrules (Detail B).

Signal cable termination

Make sure that the cable end ferrules do not touch the wire shields on the sensor side! Minimum distance = 1 mm (0.04"), exception "GND" = green cable.

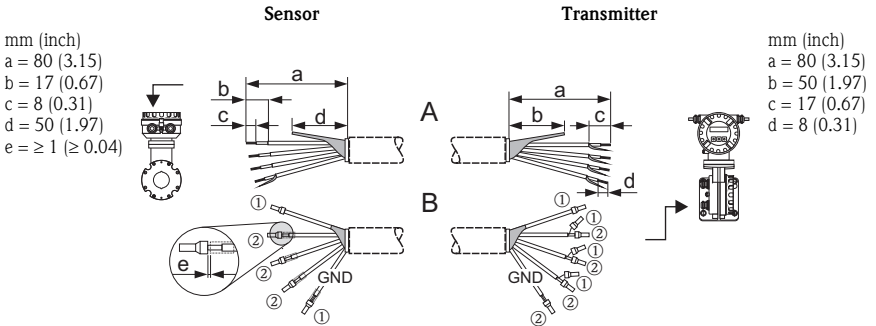

A0010760

Coil current cable termination

Insulate one core of the three-core cable at the level of the core reinforcement; you only require two cores for the connection.

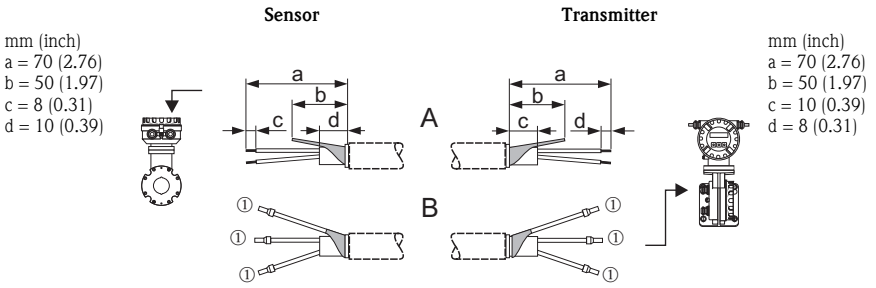

A0010761

3.3 Potential equalization

Perfect measurement is only ensured when the fluid and the sensor have the same electrical potential. This is ensured by the two ground disks of the sensor.

The following should also be taken into consideration for potential equalization:

- Internal grounding concepts in the company
- Operating conditions, such as the material/grounding of the pipes, cathodic protection etc.

Standard situation

Potential equalization takes place via the ground terminal of the transmitter when using the device in the following pipes:

- Metal, grounded pipe
- Plastic pipe
- Pipe with insulating lining



Note!

When installing in metal pipes, we recommend you connect the ground terminal of the transmitter housing with the piping.

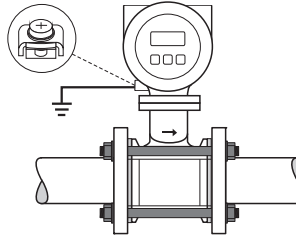

a0010702



Note!

Potential equalization for other areas of application → Operating Instructions on the CD-ROM.

3.4 Degree of protection

The devices meet all the requirements for IP 67.

After mounting in the field or service work, the following points have to be observed to ensure that IP 67 protection is retained:

- Install the measuring device in such a way that the cable entries do not point upwards.
- Do not remove the seal from the cable entry.
- Remove all unused cable entries and plug them with suitable/certified drain plugs.
- Use cable entries and drain plugs with a long-term operating temperature range in accordance with the temperature specified on the nameplate.

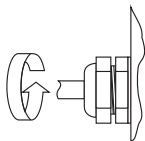

A0007549

Tighten the cable entries correctly.

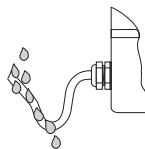

A0007550

The cables must loop down before they enter the cable entries ("water trap").

3.5 Post-connection check

- Are cables or the device damaged (visual inspection)?
- Does the supply voltage match the information on the nameplate?
- Do the cables used comply with the necessary specifications?
- Do the mounted cables have adequate strain relief and are they routed securely?
- Is the cable type route completely isolated? Without loops and crossovers?
- Are all screw terminals firmly tightened?
- Have all the measures for grounding and potential equalization been correctly implemented?
- Are all cable entries installed, firmly tightened and correctly sealed?
- Cable routed as a "water trap" in loops?
- Are all the housing covers installed and securely tightened?

4 Commissioning

4.1 Switching on the measuring device

On completion of the installation (successful post-installation check), wiring (successful post-connection check) and after making the necessary hardware settings, where applicable, the permitted power supply (see nameplate) can be switched on for the measuring device.

When the power supply is switched on, the measuring device performs a number of power-up checks and device self-checks. As this procedure progresses the following messages can appear on the onsite display:

Display examples:

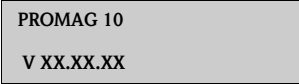

PROMAG 10
V XX.XX.XX

Startup message

The measuring device starts operating as soon as the startup procedure is complete. Various measured values and/or status variables appear on the display.



Note!

If an error occurs during startup, this is indicated by an error message.

4.2 Operation

4.2.1 Display elements

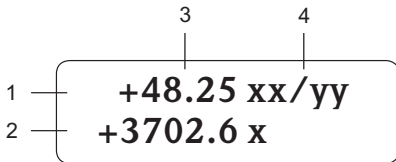

A0007557

Display lines/fields

1. Main line for primary measured values
2. Additional line for additional measured variables/status variables
3. Current measured values
4. Engineering units/time units

4.2.2 Operating elements

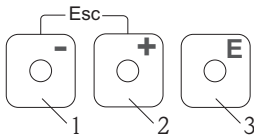

A0007559

Operating keys

1. (-) Minus key for entering, selecting
2. (+) Plus key for entering, selecting
3. Enter key for calling the function matrix, saving

When the +/- keys are pressed simultaneously (Esc):

- Exit the function matrix step-by-step:
- > 3 sec. = cancel data input and return to the measured value display

4.2.3 Displaying error messages

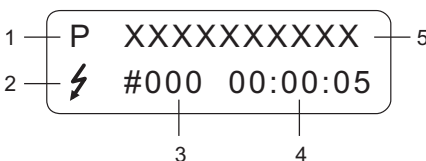

A0007561

1. Type of error:
P = Process error, S = System error
2. Error message type:
⚡ = Fault message, ! = Notice message
3. Error number
4. Duration of the last error that occurred:
Hours: Minutes: Seconds
5. Error designation
List of all error messages, see associated Operating Instructions on the CD-ROM

4.3 Navigating within the function matrix

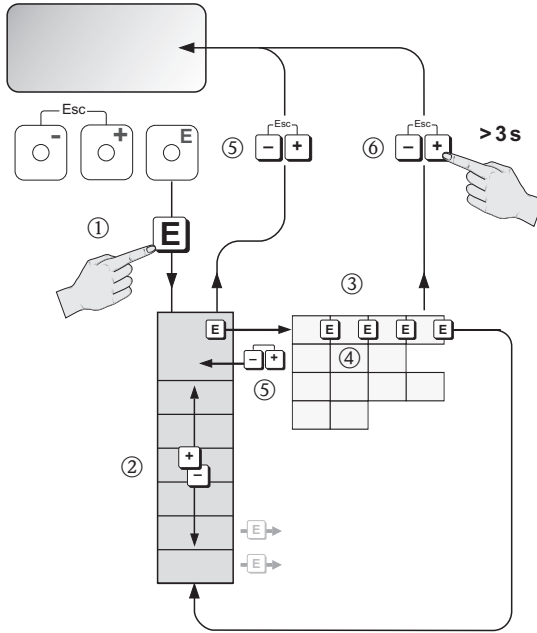

A0012683

1. → Enter the function matrix (starting with measured value display)
2. → Select the group (e.g. OPERATION)
 → Confirm selection
3. → Select function (e.g. LANGUAGE)
4. → Enter code **10** (only for the first time you access the function matrix)
 → Confirm entry
- Change function/selection (e.g. ENGLISH)
 → Confirm selection
5. → Return to measured value display step by step
6. > 3 s → Return immediately to measured value display

4.4 Device functions to be configured during commissioning

Check the values and settings of the device functions **not** marked gray in the following function matrix (UNIT VOL. FLOW, UNIT VOLUME, LANGUAGE, CURRENT RANGE etc.) and adapt them to your application.

A complete description of all the device functions is provided in the Operating Instructions on the CD-ROM.

Group	Device functions					
SYSTEM UNITS	→	UNIT VOL. FLOW	UNIT VOLUME	FORMAT DATE/TIME		
OPERATION	→	LANGUAGE	ACCESS CODE	DEFINE PRIVATE CODE		
USER INTERFACE	→	FORMAT	CONTRAST LCD	TEST DISPLAY		
TOTALIZER	→	SUM	OVERFLOW	RESET TOTALIZER		
CURRENT OUTPUT	→	CURRENT RANGE	VALUE 20 mA	TIME CONSTANT		
PULSE/STATUS OUTP.	→	OPERATING MODE	PULSE VALUE	PULSE WIDTH	OUTPUT SIGNAL	
			ASSIGN STATUS	SWITCH-ON POINT	SWITCH-OFF POINT	
COMMUNICATION	→	TAG NAME	TAG DESCR.	BUS ADDRESS	HART WRITE PROTECT.	MANUFACTURER ID DEVICE ID
PROCESS PARAM.	→	LOW FLOW CUT OFF	EPD	EPD ADJ.		
SYSTEM PARAM.	→	INSTALL. DIRECTION	MEASURING MODE	POS. ZERO RET.	SYSTEM DAMP.	
SENSOR DATA	→	CALIBRAT. DATE	K-FACTOR	ZERO POINT	NOMINAL DIAMETER	MEASURING PERIOD EPD ELECTRODE
SUPERVISION	→	FAILSAFE MODE	ALARM DELAY	SYSTEM RESET	SELF CHECKING	
SIMULAT. SYSTEM	→	SIM. FAILSAFE	SIM. MEASURAND	VALUE SIM. MEASURAND		
SENSOR VERSION	→	SERIAL NUMBER	SENSOR TYPE			
AMPLIFIER VERS.	→	SW REV.				

4.5 Troubleshooting

A complete description of all the error messages is provided in the Operating Instructions on the CD-ROM.



Note!

The output signals (e.g. pulse, frequency) of the measuring device must correspond to the higher-order controller.

www.endress.com/worldwide

Endress+Hauser 
People for Process Automation

KA00036D/06/EN/13.15
71299364
FM+SGML 6.0