



Level



Pressure



Flow



Temperature



Liquid
Analysis



Registration



Systems
Components



Services



Solutions

Operating Instructions

Proservo NMS5/7 Series

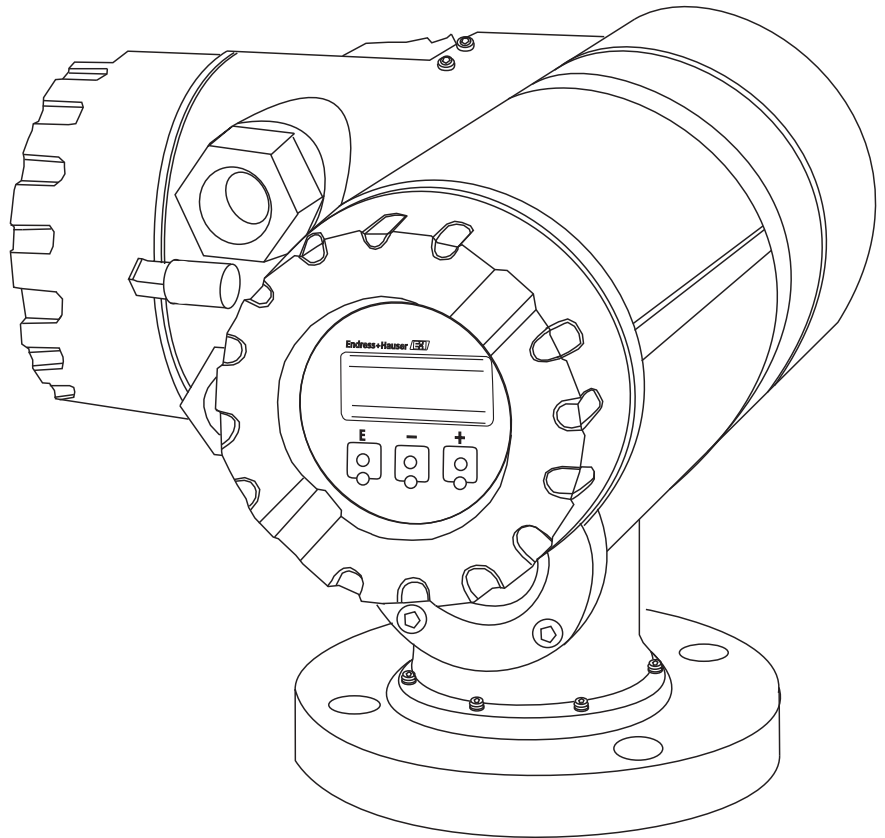

Table of contents

1. Safety instructions	3	7. Commissioning	53
1.1 Designated use	3	7.1 Initial settings	53
1.2 Installation, commissioning and operation	3	7.2 Settings for Prothermo NMT 53x Connections	56
1.3 Product Requirements	3	7.3 Settings for Promonitor NRF 560 Connections	57
1.4 Operational safety	4	7.4 Liquid Level Calibration	58
1.5 Return	4	7.5 Remote Communications	61
1.6 Disposal	5	7.6 Density Measurement and Density Profile Measurement	65
1.7 Gauge Software	5	7.7 Interface Measurement	72
1.8 Contact addresses of Endress+Hauser	5	7.8 Sealing of the Proservo	73
1.9 Notes on safety conventions and symbols	6		
2. Identification	7	8. Diagnosis and Troubleshooting	74
2.1 Device designation	7	8.1 Selection of Diagnostic Code and History	74
2.2 Product structure	11	8.2 Error and Status Messages	75
2.3 Supplied documentation	16	8.3 Diagnostics and Troubleshooting: Flowcharts	77
2.4 CE marks, declaration of conformity	16	8.4 Setting after parts replacement	84
2.5 Registered trademarks	16	8.5 Intelligent Function	85
		8.6 Spare Parts	86
3. Installation	17	9. Displacer and Measuring Wire	89
3.1 Terms related to the tank measurements	17	9.1 Shape, Diameter, and Material	89
3.2 Design, dimensions	18	9.2 Alarm History Display	90
3.3 Necessary Tools for Installation	19	9.3 List of Alarm Messages	90
		9.4 Initial Weight Calibration	91
4. Mounting	20	10. Accessories	94
4.1 Application drawing for tank	20	10.1 Calibration chamber	94
4.2 Mounting without Guide System	21	10.2 Power+Control Switch	94
4.3 Mounting with Stilling Well	21	10.3 Ball valve NHV4A	95
4.4 Mounting with Guide Wire	23	10.4 Reducing Flange NHF4	95
4.5 Mounting Preparations	26		
4.6 Electrostatic Charge	27	11. Technical data	96
4.7 Installation for Wire Drum and displacer	28	11.1 Technical Specifications	96
		12. Matrix	97
5. Wiring	32	12.1 Programming Matrix	97
5.1 Wiring Connection	32	12.2 Description of the Programming Matrix	107
5.2 Terminal assignment	33		
5.3 Temperature input system	40	13. Appendix	145
		13.1 RS 485 MODBUS (COM- 5) Terminator	145
6. Operation	42	13.2 Changing measurement wire	147
6.1 Touch Control and Programming Matrix	42	13.3 The type of draft of displacer	149
6.2 HOME Position	45		
6.3 Access Code	47		
6.4 Operation Command and New Operation Status	48		
6.5 Operation of the Displacer	50		
6.6 Calculation of Level and Densities	51		

1 Safety instructions

1.1 Designated use

The Proservo NMS5/7 series of intelligent tank gauges are designed for high accuracy liquid level measurement in storage and process applications.

They fulfill the exact demands of tank inventory management, loss control, total cost saving and safe operation.

Tank mounted intelligence makes the Proservo NMS5/7 series ideal for single or multi-task installation, converting a wide range of measurement functions.

1.2 Installation, commissioning and operation

- Mounting, electrical installation, start-up and maintenance of the instrument may only be carried out by trained personnel authorized by the operator of the facility.
- Personnel must absolutely and without fail read and understand this Operating Manual before carrying out its instructions.
- The instrument may only be operated by personnel who are authorized and trained by the operator of the facility. All instructions in this manual are to be observed without fail.
- The installer must make sure that the measuring system is correctly wired according to the wiring diagrams. The measuring system is to be grounded.
- Please observe all provisions valid for your country and pertaining to the opening and repairing of electrical devices.

1.3 Product Requirements

Power source

Check the voltage of the power supply before connecting it to the product. It should be the exact voltage required for proper operation of the product.

Use in hazardous areas

When using the product in the first or second-class hazard location (Zone 1 or Zone 2) be sure to use an intrinsically safe or pressure and explosion-proof apparatus. Take the utmost care during the installation, wiring, and piping of such apparatus to ensure the safety of the system. For safety reasons, maintenance or repairs on the product while it is being used with such apparatus should only be performed by qualified personnel.

External connection

When an external connection is required, the product should be protectively grounded before it is connected to a measurement object or an external control circuit.

Caution!

To avoid injury or damage to the device:

Release pressure in the device before removing plugs, drum housing cover or calibration windows.

1.4 Operational safety

Hazardous area

Measuring systems for use in hazardous environments are accompanied by separate "Ex documentation", which is an integral part of this Operating Manual. Strict compliance with the installation instructions and ratings as stated in this supplementary documentation is mandatory.

- Please use the explosion-proof type for measurement in explosion-hazardous areas.
- Instruments used in explosion hazardous areas should be mounted and wired according to the explosion-proof regulations.
- Instruments mounted in explosion hazardous areas must not be opened when the power is on. Tighten the cable gland firmly.
- The maintenance and repair of the instrument is limited to fulfill the explosion proof regulations.
- Ensure that all personnel are suitably qualified.
- Observe the specifications in the certificate as well as national and local regulations.

Power supply

Check that voltage and frequency of the local power supply are in the range of the technical data of the instrument before turning on the power. Please refer to Sect. 10.

Power cable

- Use the power supply cable attached to the instrument when it is ordered from the manufacturer, or the cable specified in the instruction.
- The power source should have a ground terminal, and the power supply cable should have a ground line. Please refer to Sect. 5.

Grounding

- Do not remove the grounding of the instrument when the power supply is turned on. This may set the instrument in a dangerous condition.

Wiring



Make sure of the grounding of the instrument before connecting input and output to another system.

Use of the instrument

The Proservo NMS5/7series is designed for level measurement of a liquid in a storage tank or similar facilities.

It is possible to connect auxiliary instruments in the specification described in this manual.

However, the performance of the connected instruments is not guaranteed. Please refer to the instructions attached to the individual instruments when they are connected.

A hazardous situation may occur if the instrument is used for a purpose that is not designed for or any other improper ways. The instrument has an IEC class 1 (ground terminal).



Caution!

Changes or modifications not expressly approved by the party responsible for compliance could void the user's authority to operate the equipment.

1.5 Return

The following procedures must be carried out before the instruments is sent to Endress+Hauser for repair:

- Always enclose a duly completed "Declaration of Contamination" form. Only then can Endress +Hauser transport, examine and repair a returned device.
- Enclose special handling instructions if necessary, for example, safety data sheet as per EN 91/155/EEC.
- Remove all residue which may be present. Pay special attention to the gasket grooves and crevices where fluid may be present. This is especially important if the fluid is dangerous to health, e.g. corrosive, poisonous, carcinogenic, radioactive, etc.

A copy of the “**Declaration of Contamination**” is included at the end of this operating manual.



Caution!

- No instrument should be sent back for repair without all dangerous material being completely removed first, e.g. in scratches or diffused through plastic.
- Incomplete cleaning of the instrument may result in waste disposal or cause harm to personnel (burns, etc.). Any costs arising from this will be charged to the operator of the instrument.

1.6 Disposal

In case of disposal, please separate the different components according to their material consistency.

1.7 Gauge Software











Software version / Date	Software changes	Documentation changes
V2.13, from 9.96	Original Release	BA001N/08/en/09.98
V2.20, from 10.97	T2:TCB-2, Modified V1: R&S command	BA001N/08/en/11.97
V4.06, from 04.98	HART master, T4:TCB-4	
V4.06, from 04.98	HART master T&W, T4:TCB-4	
V4.08X, from 08.98	upper stop speed reduction 3-step	
V4.20, from 08.98	WM550, Commuwin II display, elem. Error fix	BA001N/08/en/12.99
V4.20, from 09.98	T&W	BA001N/08/en/12.99
V4.22, from 05.00	HART line selection add to static matrix: gas temp. minus data remote communication level 6 digit data processing memory clear volume calculation matrix deleted	
V4.23B, from 09.00	standard release, alarm output modify, NMT level selection	
V4.24, from 04.01	standard release	BA001N/08/en/03.01
V4.24 OSP, from 06.01	Over Spill protection	
V4.24T&W, from 07.01	T&W spec.	
V4.24 T2, from 02.02	TCB-2 CPU, NMT, V1 level measurement	
V4.25, from 09.02	Density profile function	BA001N/08/en/02.02
V4.27, from 09.04	Level hold matrix, Error display on Home screen only	BA001N/08/en/11.04
V4.27 T6/T&O, from 11.05	W&M and Overspill protection	BA001N/08/en/03.06
V4.27 A, from 05.07	standard release	
V4.27 B, from 09.08	standard release	BA1001N/08/en/12.08
V4.27 C, from 04.09	Proactive Safety function	BA1001N/08/en/04.09

1.8 Contact addresses of Endress+Hauser

The addresses of Endress+Hauser are given on the back cover of this operating manual. If you have any questions, please do not hesitate to contact your E+H representative.

1.9 Notes on safety conventions and symbols

In order to highlight safety-relevant or alternative operating procedures in the manual, the following conventions have been used, each indicated by a corresponding symbol in the margin.

Safety conventions	
	Warning! A warning highlights actions or procedures which, if not performed correctly, will lead to personal injury, a safety hazard or destruction of the instrument
	Caution! Caution highlights actions or procedures which, if not performed correctly, may lead to personal injury or incorrect functioning of the instrument
	Note! A note highlights actions or procedures which, if not performed correctly, may indirectly affect operation or may lead to an instrument response which is not planned
Explosion protection	
	Device certified for use in explosion hazardous area If the device has this symbol embossed on its name plate, it can be installed in an explosion hazardous area
	Explosion hazardous areas Symbol used in drawings to indicate explosion hazardous areas. – Devices located in and wiring entering areas with the designation “explosion hazardous areas” must conform with the stated type of protection
	Safe area (non-explosion hazardous area) Symbol used in drawings to indicate, if necessary, non-explosion hazardous areas. – Devices located in safe areas still require a certificate if their outputs run into explosion hazardous areas
Explosion protection	
	Direct voltage A terminal to which or from which a direct current or voltage may be applied or supplied
	Alternating voltage A terminal to which or from which an alternating (sine-wave) current or voltage may be applied or supplied
	Grounded terminal A grounded terminal, which as far as the operator is concerned, is already grounded by means of an earth grounding system
	Protective grounding (earth) terminal A terminal which must be connected to earth ground prior to making any other connection to the equipment
	Equipotential connection (earth bonding) A connection made to the plant grounding system which may be of type e.g. neutral star or equipotential line according to national or company practice

2 Identification

2.1 Device designation

2.1.1 Nameplate





The following technical data are given on the instrument nameplate:

<p>Endress+Hauser PROSERVO NMS53 </p> <p>Order Code <input type="text"/> ②</p> <p>Ser. No: <input type="text"/> ③</p> <p>SUPPLY <input type="text"/> ④</p> <p>IP67</p> <p>MEASURING RANGE <input type="text"/> ⑤ m</p> <p>DISPLACER WEIGHT <input type="text"/> ⑥ g</p> <p>DISPLACER DIA. <input type="text"/> ⑦ mmφ</p> <p>MEASURE. WIRE DIA. <input type="text"/> ⑧ mmφ</p> <p>DENSITY RANGE <input type="text"/> ⑨ ~ <input type="text"/> ⑩</p> <p>MANUFACTURING DATE <input type="text"/> ⑪</p> <p>TEST DATE <input type="text"/> ⑫</p> <p>TESTER <input type="text"/> ⑬</p> <p>Zero point of liquid level gauge is <input type="text"/> ⑭ mm under the reference point.</p> <p>Only read level when indication "BAL" is present.</p> <p>Ex EEExd II B T6 ATEX II 2G or II 1/2 G </p> <p>KEMA 05 ATEX 2071</p> <p>Ambient Temperature: -20 ~ 60°C</p> <p>CERTIFICATION No. <input type="text"/> ⑮</p> <p>TANK ID <input type="text"/> ⑯</p> <p> <input type="text"/> ⑰</p> <p>DO NOT REMOVE COVER UNLESS POWER IS DISCONNECTED.</p> <p>Endress+Hauser Yamanashi Co., Ltd. Made in Japan Yamanashi 406-0846 NP-2514-2</p>	<table border="1"> <tr><td>①</td><td>drum housing specification</td></tr> <tr><td>②</td><td>complete product designation</td></tr> <tr><td>③</td><td>serial number</td></tr> <tr><td>④</td><td>power supply specification</td></tr> <tr><td>⑤</td><td>measuring range</td></tr> <tr><td>⑥</td><td>displacer weight</td></tr> <tr><td>⑦</td><td>displacer diameters</td></tr> <tr><td>⑧</td><td>measuring wire</td></tr> <tr><td>⑨</td><td>density measurement lower limit</td></tr> <tr><td>⑩</td><td>density measurement upper limit</td></tr> <tr><td>⑪</td><td>date of manufacture</td></tr> <tr><td>⑫</td><td>date of manufacture test</td></tr> <tr><td>⑬</td><td>name of tester</td></tr> <tr><td>⑭</td><td>reference point (W&M)</td></tr> <tr><td>⑮</td><td>certificate number (excluding Ex)</td></tr> <tr><td>⑯</td><td>PTB W&M certificate number</td></tr> <tr><td>⑰</td><td>PTB W&M certificate number</td></tr> </table>	①	drum housing specification	②	complete product designation	③	serial number	④	power supply specification	⑤	measuring range	⑥	displacer weight	⑦	displacer diameters	⑧	measuring wire	⑨	density measurement lower limit	⑩	density measurement upper limit	⑪	date of manufacture	⑫	date of manufacture test	⑬	name of tester	⑭	reference point (W&M)	⑮	certificate number (excluding Ex)	⑯	PTB W&M certificate number	⑰	PTB W&M certificate number
①	drum housing specification																																		
②	complete product designation																																		
③	serial number																																		
④	power supply specification																																		
⑤	measuring range																																		
⑥	displacer weight																																		
⑦	displacer diameters																																		
⑧	measuring wire																																		
⑨	density measurement lower limit																																		
⑩	density measurement upper limit																																		
⑪	date of manufacture																																		
⑫	date of manufacture test																																		
⑬	name of tester																																		
⑭	reference point (W&M)																																		
⑮	certificate number (excluding Ex)																																		
⑯	PTB W&M certificate number																																		
⑰	PTB W&M certificate number																																		



ATEX Approval Type Ex d/Ex d[ia] (NMS5-2, 5-5, 5-6 only)

<p>Endress+Hauser PROSERVO NMS53 </p> <p>Order Code <input type="text"/> ②</p> <p>Ser. No: <input type="text"/> ③</p> <p>SUPPLY <input type="text"/> ④</p> <p>IP67</p> <p>MEASURING RANGE <input type="text"/> ⑤ m</p> <p>DISPLACER WEIGHT <input type="text"/> ⑥ g</p> <p>DISPLACER DIA. <input type="text"/> ⑦ mmφ</p> <p>MEASURE. WIRE DIA. <input type="text"/> ⑧ mmφ</p> <p>DENSITY RANGE <input type="text"/> ⑨ ~ <input type="text"/> ⑩</p> <p>MANUFACTURING DATE <input type="text"/> ⑪</p> <p>TEST DATE <input type="text"/> ⑫</p> <p>TESTER <input type="text"/> ⑬</p> <p>Zero point of liquid level gauge is <input type="text"/> ⑭ mm under the reference point.</p> <p>Only read level when indication "BAL" is present.</p> <p>Ex EEExd II B T6 ATEX II 2G or II 1/2 G </p> <p>KEMA 05 ATEX 2071</p> <p>Ambient Temperature: +40 ~ 60°C</p> <p>CERTIFICATION No. <input type="text"/> ⑮</p> <p>TANK ID <input type="text"/> ⑯</p> <p> <input type="text"/> ⑰</p> <p>DO NOT REMOVE COVER UNLESS POWER IS DISCONNECTED.</p> <p>Endress+Hauser Yamanashi Co., Ltd. Made in Japan Yamanashi 406-0846 NP-2515-2</p>	<table border="1"> <tr><td>①</td><td>drum housing specification</td></tr> <tr><td>②</td><td>complete product designation</td></tr> <tr><td>③</td><td>serial number</td></tr> <tr><td>④</td><td>power supply specification</td></tr> <tr><td>⑤</td><td>measuring range</td></tr> <tr><td>⑥</td><td>displacer weight</td></tr> <tr><td>⑦</td><td>displacer diameters</td></tr> <tr><td>⑧</td><td>measuring wire</td></tr> <tr><td>⑨</td><td>density measurement lower limit</td></tr> <tr><td>⑩</td><td>density measurement upper limit</td></tr> <tr><td>⑪</td><td>date of manufacture</td></tr> <tr><td>⑫</td><td>date of manufacture test</td></tr> <tr><td>⑬</td><td>name of tester</td></tr> <tr><td>⑭</td><td>reference point (W&M)</td></tr> <tr><td>⑮</td><td>certificate number (excluding Ex)</td></tr> <tr><td>⑯</td><td>PTB W&M certificate number</td></tr> <tr><td>⑰</td><td>PTB W&M certificate number</td></tr> </table>	①	drum housing specification	②	complete product designation	③	serial number	④	power supply specification	⑤	measuring range	⑥	displacer weight	⑦	displacer diameters	⑧	measuring wire	⑨	density measurement lower limit	⑩	density measurement upper limit	⑪	date of manufacture	⑫	date of manufacture test	⑬	name of tester	⑭	reference point (W&M)	⑮	certificate number (excluding Ex)	⑯	PTB W&M certificate number	⑰	PTB W&M certificate number
①	drum housing specification																																		
②	complete product designation																																		
③	serial number																																		
④	power supply specification																																		
⑤	measuring range																																		
⑥	displacer weight																																		
⑦	displacer diameters																																		
⑧	measuring wire																																		
⑨	density measurement lower limit																																		
⑩	density measurement upper limit																																		
⑪	date of manufacture																																		
⑫	date of manufacture test																																		
⑬	name of tester																																		
⑭	reference point (W&M)																																		
⑮	certificate number (excluding Ex)																																		
⑯	PTB W&M certificate number																																		
⑰	PTB W&M certificate number																																		

ATEX Approval Type Ex d/Ex d[ia]

<p>Endress+Hauser  PROSERVO NMS53 </p> <p>Order Code: <input type="text" value="2"/></p> <p>Ser. No.: <input type="text" value="3"/></p> <p>SUPPLY: <input type="text" value="4"/></p> <p>IP67</p> <p>MEASURING RANGE: <input type="text" value="5"/> m DISPLACER WEIGHT: <input type="text" value="6"/> g DISPLACER DIA.: <input type="text" value="7"/> mmφ MEASURE. WIRE DIA.: <input type="text" value="8"/> mmφ DENSITY RANGE: <input type="text" value="9"/> ~ <input type="text" value="10"/> MANUFACTURING DATE: <input type="text" value="11"/> TEST DATE: <input type="text" value="12"/> TESTER: <input type="text" value="13"/></p> <p>Zero point of liquid level gauge is <input type="text" value="14"/> mm under the reference point. Only read level when indication "BAL" is present.</p> <p>Ex EEExd IIB T6 ATEX II 2G KEMA 05 ATEX 2071 Ambient Temperature: -10 ~ 60°C CERTIFICATION No.: <input type="text" value="15"/> TANK ID: <input type="text" value="16"/></p> <p>DO NOT REMOVE COVER UNLESS POWER IS DISCONNECTED. Endress+Hauser Yamanashi Co., Ltd. Made in Japan Yamanashi 406-0846</p>	<p>Endress+Hauser  PROSERVO NMS53 </p> <p>Order Code: <input type="text" value="2"/></p> <p>Ser. No.: <input type="text" value="3"/></p> <p>SUPPLY: <input type="text" value="4"/></p> <p>IP67</p> <p>MEASURING RANGE: <input type="text" value="5"/> m DISPLACER WEIGHT: <input type="text" value="6"/> g DISPLACER DIA.: <input type="text" value="7"/> mmφ MEASURE. WIRE DIA.: <input type="text" value="8"/> mmφ DENSITY RANGE: <input type="text" value="9"/> ~ <input type="text" value="10"/> MANUFACTURING DATE: <input type="text" value="11"/> TEST DATE: <input type="text" value="12"/> TESTER: <input type="text" value="13"/></p> <p>Zero point of liquid level gauge is <input type="text" value="14"/> mm under the reference point. Only read level when indication "BAL" is present.</p> <p>Ex EEExd IIB T6 ATEX II 2G KEMA 05 ATEX 2071 Ambient Temperature: -20 ~ 60°C CERTIFICATION No.: <input type="text" value="15"/> TANK ID: <input type="text" value="16"/></p> <p>DO NOT REMOVE COVER UNLESS POWER IS DISCONNECTED. Endress+Hauser Yamanashi Co., Ltd. Made in Japan Yamanashi 406-0846</p>	<table border="1"> <tr><td>①</td><td>drum housing specification</td></tr> <tr><td>②</td><td>complete product designation</td></tr> <tr><td>③</td><td>serial number</td></tr> <tr><td>④</td><td>power supply specification</td></tr> <tr><td>⑤</td><td>measuring range</td></tr> <tr><td>⑥</td><td>displacer weight</td></tr> <tr><td>⑦</td><td>displacer diameters</td></tr> <tr><td>⑧</td><td>measuring wire</td></tr> <tr><td>⑨</td><td>density measurement lower limit</td></tr> <tr><td>⑩</td><td>density measurement upper limit</td></tr> <tr><td>⑪</td><td>date of manufacture</td></tr> <tr><td>⑫</td><td>date of manufacture test</td></tr> <tr><td>⑬</td><td>name of tester</td></tr> <tr><td>⑭</td><td>reference point (W&M)</td></tr> <tr><td>⑮</td><td>certificate number (excluding Ex)</td></tr> <tr><td>⑯</td><td>PTB W&M certificate number</td></tr> <tr><td>⑰</td><td>PTB W&M certificate number</td></tr> </table>	①	drum housing specification	②	complete product designation	③	serial number	④	power supply specification	⑤	measuring range	⑥	displacer weight	⑦	displacer diameters	⑧	measuring wire	⑨	density measurement lower limit	⑩	density measurement upper limit	⑪	date of manufacture	⑫	date of manufacture test	⑬	name of tester	⑭	reference point (W&M)	⑮	certificate number (excluding Ex)	⑯	PTB W&M certificate number	⑰	PTB W&M certificate number
①	drum housing specification																																			
②	complete product designation																																			
③	serial number																																			
④	power supply specification																																			
⑤	measuring range																																			
⑥	displacer weight																																			
⑦	displacer diameters																																			
⑧	measuring wire																																			
⑨	density measurement lower limit																																			
⑩	density measurement upper limit																																			
⑪	date of manufacture																																			
⑫	date of manufacture test																																			
⑬	name of tester																																			
⑭	reference point (W&M)																																			
⑮	certificate number (excluding Ex)																																			
⑯	PTB W&M certificate number																																			
⑰	PTB W&M certificate number																																			

Zone I ATEX Approval Type Ex d

<p>Endress+Hauser  PROSERVO NMS53</p> <p>Order Code: NMS5- <input type="text" value="1"/></p> <p>Ser. No.: <input type="text" value="2"/></p> <p>Input rated: <input type="text" value="3"/></p> <p>NEVA 4X</p> <p>INPUT: <input type="text" value="4"/></p> <p>OUTPUT: <input type="text" value="5"/></p> <p>Relay contact rated 30 V ac, 2A; 42 V dc, 2A, 60 W. MEASURING RANGE: <input type="text" value="6"/> m AMBIENT TEMPERATURE: -20 ~ 60 °C MANUFACTURING DATE: _____</p> <p>Manufacturer: Endress+Hauser Yamanashi Co., Ltd. Made in Japan Yamanashi 406-0846</p> <p>F M APPROVED XP Class I, Div. 1, Gp. CD DIP Class II, III, Div. 1, Gp. EFG Temperature Class I4 Ambient Temperature: -20 ~ +60 °C</p> <p>WARNING: KEEP COVER TIGHT WHILE CIRCUITS ARE ALIVE. CAUTION: USE SUPPLY WIRES SUITABLE FOR 70 °C MINIMUM. CAUTION: A SEAL SHALL BE INSTALLED WITHIN 50 MM OF THE ENCLOSURE.</p> <p> NP2346.2</p>	<table border="1"> <tr><td>①</td><td>complete product designation</td></tr> <tr><td>②</td><td>serial number</td></tr> <tr><td>③</td><td>power supply specification</td></tr> <tr><td>④</td><td>signal input specification</td></tr> <tr><td>⑤</td><td>signal output specification</td></tr> <tr><td>⑥</td><td>measuring range</td></tr> </table>	①	complete product designation	②	serial number	③	power supply specification	④	signal input specification	⑤	signal output specification	⑥	measuring range
①	complete product designation												
②	serial number												
③	power supply specification												
④	signal input specification												
⑤	signal output specification												
⑥	measuring range												

FM Approval Type XP

①	complete product designation
②	serial number
③	power supply specification
④	signal input specification
⑤	signal output specification
⑥	measuring range



FM Approval Type XP-AIS

①	drum housing specification
②	complete product designation
③	serial number
④	input Rating
⑤	input
⑥	output
⑦	measuring range
⑧	date of manufacture
⑨	density measurement lower limit
⑩	density measurement upper limit

CSA Approval Type Ex d[ia]

①	drum housing specification
②	complete product designation
③	serial number
④	input Rating
⑤	input
⑥	output
⑦	measuring range
⑧	date of manufacture

CSA Approval Type Ex d

	
PROSERVO NMS5/7	
Order Code	②
Ser. No.	③
防爆型式 / Ex Proof model	④
防爆構造 / Protection class	⑤
定額 / Rating	⑥
電源 / Power supply	
データ伝送回路 / Data communication: DC 48V 300mA (1伝送容量) 接点入力回路 / Contact input: DC 30V 0.6W (1接点容量) 接点出力回路 / Contact output: AC250V 1.5W (1接点容量) DC 30V 0.6W 周囲温度 / Ambient temperature: 60°C	
注意: 電源を切った後、容積熱を除去するまでは蓋を開けないでください。 全量充填の場合、二重にシール電線 (HIV-特種電線 0950-4462.2) を 使用してください。 Note: Be sure to cut off the power and cool down this instrument before opening the cover. In case of double wiring method, shall be used HIV wire (insulation resistance over 0.05M-ohm.km)	
MEASURING RANGE	⑦ m
DISPLACER WEIGHT	⑧ g
DISPLACER DIA.	⑨ mmφ
MEASURE. WIRE DIA.	⑩ mmφ
DENSITY RANGE	⑪ ~ ⑫
MANUFACTURING DATE	⑬
TEST DATE	⑭
TESTER	⑮
	
エントスハウザー山梨株式会社 Endress+Hauser Yamanashi Co., Ltd. Made in Japan Yamanashi 406-0846	

①	drum housing specification
②	complete product designation
③	serial number
④	Ex proof model
⑤	Rating
⑥	power supply
⑦	measuring range
⑧	Displacer weight
⑨	Displacer diameter
⑩	measuring wire diameter
⑪	density range lower limit
⑫	density range upper limit
⑬	date of manufacture
⑭	date of manufacture test
⑮	name of tester

TIIS Approval Type Ex d

2.2 Product structure

2.2.1 Proservo NMS5

10	Drum housing		
	1	0.2bar gauge; Alu. casting	
	2	0.2bar gauge; stainless steel	
	4	6bar gauge; Alu. casting	
	5	6bar gauge; stainless steel	
	6	25bar gauge; stainless steel	
	9	Special vesion, to be specified	
20	Protection class		
	0	Weather proof ; IP 67 / NEMA 4X	
	1	TIIS Ex d IIB T4	
	5	XP Class 1, Div. 1, Gr. CD, FM	
	6	Class 1, Div. 1, Gr. CD, CSA	
	F	ATEX II 2G EEx d IIB T6	
	G	ATEX II 1/2G EEx d IIB T6	
	H	ATEX II 2G EEx d [ia] IIB T6	
	J	ATEX II 1/2G EEx d [ia] IIB T6	
	N	XP-AIS Class 1, Div.1, Gr.CD, FM: EEx d[ia]	
	O	Class 1, Div.1, Gr.CD CSA EExd(ia)	
	Q	ATEX II 1/2G EEx d IIC T6	
	R	ATEX II 2G EEx d IIB T6, -40 dec	
	S	ATEX II 1/2G EEx d IIB T6, -40 dec	
	T	*TIIS Ex d(ia) IIB T4	
	Y	Special vesion, to be specified	
30	Measuring function		
	A	Level	
	B	PTB Weights & Measures, Level	
	C	NMi Weights & Measures, Level	
	D	Multi measurement, Level, I/F level, Bottom, Density	
	E	PTB Weights & Measures, Level, I/F level, Bottom, Density	
	F	MNi Weights & Measures, Level, I/F level, Bottom, Density	
	G	Density profile multi measurement, Level, I/F level, Bottom, Density	
	H	PTB Weights & Measures, Density profile, Level, I/F level, Bottom, Density	
	J	NMi Weights & Measures, Density profile, Level, I/F level, Bottom, Density	
	Y	Special vesion, to be specified	
40	Primary (Digital) output		
	N	Enraf BPM	
	P	RS 485 Modbus	
	Q	*Modbus, current loop, dual output	
	F	Not selected	
	A	Serial pulse (Sakura V1/MDP)	
	J	Serial pulse (Sakura MDP)	
	B	Serial pulse (Sakura BBB)	
	C	Serial pulse (Sakura MIC + RS-232C)	
	D	Serial pulse (Sakura MIC)	
	G	HART (active)	
	H	HART (passive)	
	L	Whessoe matic 550+OVP=overvoltage protection	
	M	Mark / Space	
	Y	Special vesion, to be specified	
50	Secondary output		
	0	Not selected	
	1	Alarm contact, 4x SPST	
	2	4 - 20 mA, 2 channel selectable	
	3	4 x SPST + 4 - 20 mA, 2 channels	
	4	2 x SPST, Overspill protection TÜV	
	5	4 x SPST + 4 - 20 mA, 1 channels	
	9	Special vesion, to be specified	
NMS5-			Product designation (part 1)

60	Signal input from field units
	<ul style="list-style-type: none"> 0 HART protocol (e.g. NMT, NRF) 1 HART + Pt100 Spot temp. 2 HART + Operation contact, 3digits 3 HART + Pt100 Spot temp.+ Operation contact 4 HART + 1 x status 5 HART + Pt100 Spot temp. + 1 x status 6 HART + Pt100 + Operation contact +1 x status 9 Special vesion, to be specified
70	Measuring range; Wire material
	<ul style="list-style-type: none"> A Range: 0 -10m, AISI316 wire B Range: 0 -16m, AISI316 wire C Range: 0 -28m, AISI316 wire L Range: 0 -36m, AISI316 wire G Range: 0 -10m, AISI316 wire PFA covered H Range: 0 -16m, AISI316 wire PFA covered J Range: 0 -10m, Alloy C K Range: 0 -16m, Alloy C Y Special version, to be specified
80	Cable entry
	<ul style="list-style-type: none"> E Four thread G(PF)1/2" F Four thread G(PF)3/4" G Four thread NPT1/2" H Four thread NPT3/4" J Four thread PG 16 K Four thread PG 21 L Four thread M20 M Four thread M25 Y Special version, to be specified
90	Process connection
	<ul style="list-style-type: none"> A Flange JIS10 K 80A RF C Flange JIS10 K 80A FF E Flange JIS 20 K 80A RF (only for 25bar drum chamber) G Flange ANSI 3" 150 lbs RF J Flange ANSI 3" 300 lbs RF (only for 25bar drum chamber) U Flange JIS10 K 150A RF T Flange ANSI 6" 150 lbs RF L Flange DIN DN80 PN10 RF N Flange DIN DN80 PN25 RF (only for 25bar drum chamber) Q Flange JPI 3" 150 lbs RF S Flange JPI 3" 300 lbs RF (only for 25bar drum chamber) Y Special version, to be specified
100	Power supply
	<ul style="list-style-type: none"> 3 85 - 264 VAC, 50/60 Hz 4 20 - 62 VDC/ 20 - 55 VAC, 50/60 Hz, 9 Special version, to be specified
110	Displacer shape, diameter, material
	<ul style="list-style-type: none"> B Conical 50 mm, PTFE D Cylindrical 50 mm, AISI316 (standard) K Cylindrical 40 mm, AISI316 N Cylindrical 30 mm, AISI316 R 70 mm, W&M NMI S 110 mm, W&M PTB T Cylindrical 50 mm, Alloy C U Cylindrical 50 mm, PTFE V Cylindrical 40 mm, PTFE W Cylindrical 30 mm, PTFE Y Special version, to be specified
NMS5-	Product designation (part 1)

120	O-ring; chamber finishing
	<ul style="list-style-type: none"> 0 NBR; Standard chamber 1 Silicon rubber, Standard chamber 2 Fluor rubber, Standard chamber 3 PTFE (Wire drum FKM), Basic version 4 PTFE (Wire drum FKM), PFA coated 5 Silicon rubber, PTFE coated chamber 6 Neoprene (ammonia application), standard chamber 9 Special version
130	Options
	<ul style="list-style-type: none"> A not selected C With cleaning nozzle D With gas purging nozzle E With guide wires (AISI316 standard) G With relief valve H With relief valve + pressure gauge J Sunshade Y Special version
NMS5-	Complete product designation

2.2.2 Proservo NMS7 (Sanitary version)

10		Protection class	
	0	IP 67 / NEMA 4X	
	1	TIIS Ex d IIB T4	
	9	Special version, to be specified	
20		Measuring function	
	A	Level	
	B	Level, I/F level, Density	
	Y	Special version, to be specified	
30		Primary (Digital) output	
	N	Enraf BPM	
	P	RS485 Modbus	
	F	Not selected	
	A	Serial pulse (Sakura V1/MDP)	
	J	Serial pulse (Sakura MDP)	
	B	Serial pulse (Sakura BBB)	
	C	Serial pulse (Sakura MIC + RS-232C)	
	D	Serial pulse (Sakura MIC)	
	G	HART (active)	
	H	HART (passive)	
	L	Whessoematic 550, with lightning protection	
	M	Mark / Space	
	Y	Special version, to be specified	
40		Secondary output	
	0	Not selected	
	1	Alarm contact, 4x SPST	
	2	4 - 20 mA , 2 channel selectable	
	3	4 x SPST + 4 - 20 mA, 2 channels	
	4	2 x SPST; Overspill protection, TÜV	
	5	4 x SPST; 4 - 20 mA, 1 channel	
	9	Special version, to be specified	
50		Signal input from field units	
	0	HART protocol (e.g. NMT, NRF)	
	1	HART + Pt100 Spot temp.	
	2	HART + Operation contact, 3digits	
	3	HART + Pt100 Spot temp.+ Operation contact	
	4	HART + 1 x status	
	5	HART + Pt100 Spot temp. + 1 x status	
	6	HART + Pt100 + Operation contact +1 x status	
	9	Special version, to be specified	
60		Measuring range, wire material	
	A	Range: 0 -10m, wire d=0.2 mm,AISI316	
	B	Range: 0 -16m, wire d=0.2 mm,AISI316	
	C	Range: 0 -10m, wire d=0.4 AISI316 PFA covered	
	D	Range: 0 -16m, wire d=0.4 AISI316 PFA covered	
	Y	Special version, to be specified	
70		Cable entry	
	A	Four thread G(PF)1/2"	
	B	Four thread G(PF)3/4"	
	C	Four thread NPT1/2"	
	D	Four thread NPT3/4"	
	E	Four thread PG 16	
	F	Four thread PG 21	
	G	Four thread M20	
	H	Four thread M25	
	Y	Special version, to be specified	
NMS7-		Product designation (part 1)	

80																Process Connection
																A Flange JIS10 K 80A RF B Flange JIS10 K 80A FF C Flange ANSI 3" 150 lbs RF D Flange DIN DN80 PN10 RF E Flange JPI 3" 150 lbs RF Y Special version, to be specified
90																Power supply
																0 85 - 264 VAC, 50/60 Hz 1 20 - 62 VDC/ 20 - 55 VAC, 50/60 Hz 9 Special version, to be specified
100																Displacer shape, diameter, material
																A Cylindrical 50 mm; AISI316 buff finished B Cylindrical 40 mm; AISI316 polished finished C Cylindrical 30 mm, AISI316 polished finished D Cylindrical 50 mm, PTFE E Cylindrical 40 mm, PTFE F Cylindrical 30 mm, PTFE Y Special version, to be specified
110																O-ring; chamber finishing
																0 NBR; Standard chamber milling finished 1 Silicon; Standard chamber buff finished 2 Fluor rubber, basic version 5 Silicon rubber, PTFE coated chamber 9 Special version, to be specified
120																Nozzle
																A With cleaning nozzle PT 3/8" threaded B With cleaning nozzle NPT 3/8" threaded C With cleaning nozzle PF 3/8" threaded D With gas purging nozzle PT 3/8" threaded E With gas purging nozzle NPT 3/8" threaded F With gas purging nozzle PF 3/8" threaded G With cleaning + gas purging nozzle PT 3/8" threaded H With cleaning + gas purging nozzle NPT 3/8" threaded J With cleaning + gas purging nozzle PF 3/8" threaded Y Special version, to be specified
130																Additional Option
																A Not selected B Sealing function C Degreased D Sun shade E Sealing function + Degreased F Sealing function + Sun shade G Sun shade + Degreased H Sealing function, Sun shade + Degreased Y Special version, to be specified
NMS7-																Complete product designation

2.3 Supplied documentation

Document	Designation	Content/Remarks
BA1001N	Operating manual	describes installation, commissioning operating and maintenance of the Proservo NMS5/7.
XA 001N	Safety Instructions	only for instrument versions approved for use in explosion hazardous areas; the nameplate specifies, which of these documents is relevant for your instrument version

2.4 CE marks, declaration of conformity

The instrument is designed to meet state-of-the-art safety requirements, has been tested and left the factory in a condition in which it is safe to operate. The instrument complies with the applicable standards and regulations in accordance with EN 50014 "Electrical apparatus for potentially explosive atmospheres-General requirements". The instrument described in this manual thus complies with the statutory requirements of the EG directives. Endress+Hauser confirms the successful testing of the instrument by affixing to it the CE mark.

2.5 Registered trademarks

HART®

Registered trademark of HART Communication Foundation, Austin, USA

3 Installation

3.1 Terms related to the tank measurements

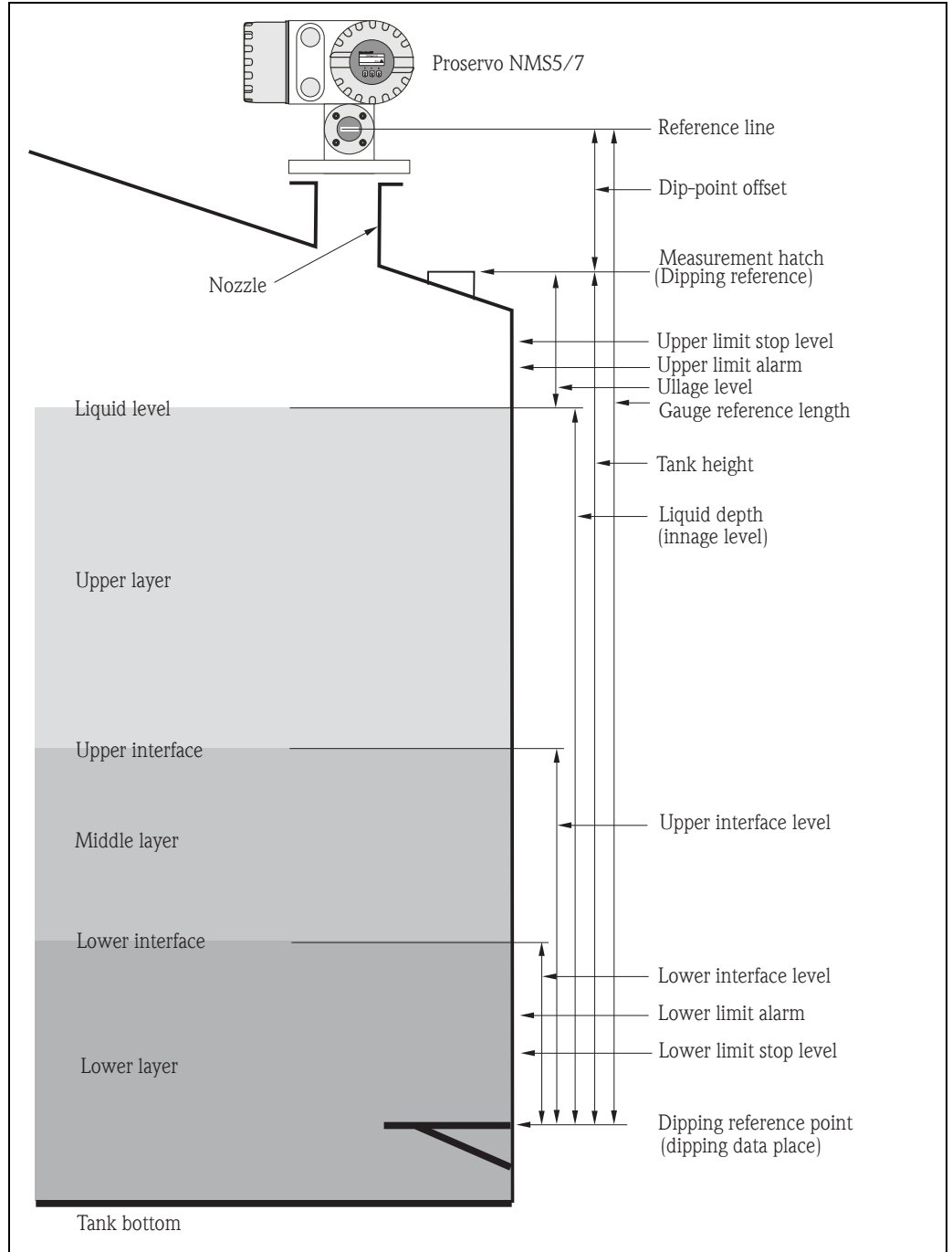

Terms related to the tank measurements

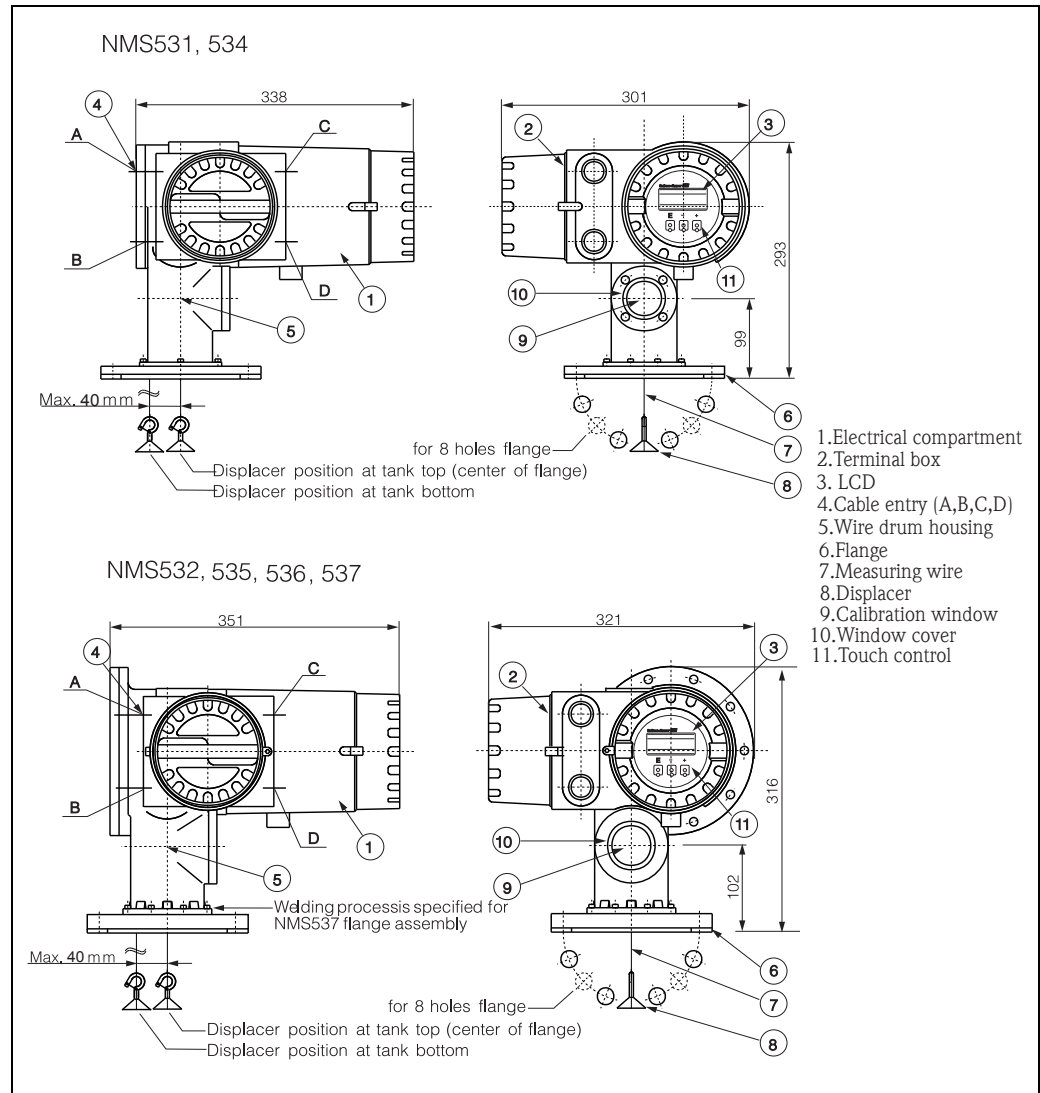

3.2 Design, dimensions



Proservo NMS5/7 Dimension

3.3 Necessary Tools for Installation

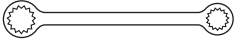
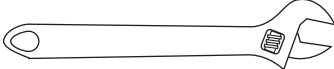
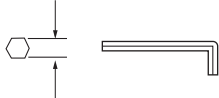
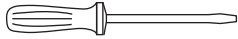
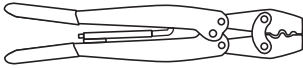
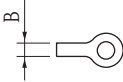
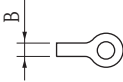
You will need the following tools when installing the Proservo NMS5/7.

Box end wrench	 <u>24,26,30,32 mm</u>
Crescent wrench	 <u>350 mm</u>
Allen wrench (hex key)	 <u>3mm and 5mm</u>
Screw driver ■ flat head ■ Philips	 
Wire Cutters / Terminal pliers	
Wire terminal	 <u>3 mm</u> <u>1.25^{sq}, 2.0^{sq}</u>
Water pump pliers	

4 Mounting

The following installation procedures are available for the Proservo NMS5/7.

- Mounting without guide system.
- Mounting with stilling well (also called pipe)
- Mounting with guide wire

4.1 Application drawing for tank

Mounting with stilling well or guide wire is required for the following applications:

- Floating roof tank
- Covered floating roof tank
- Tank with strong agitator or heavy turbulence

Mounting without any guide system covers all cases that are not listed above.

Fig. 8 shows examples of applications with and without stilling well.

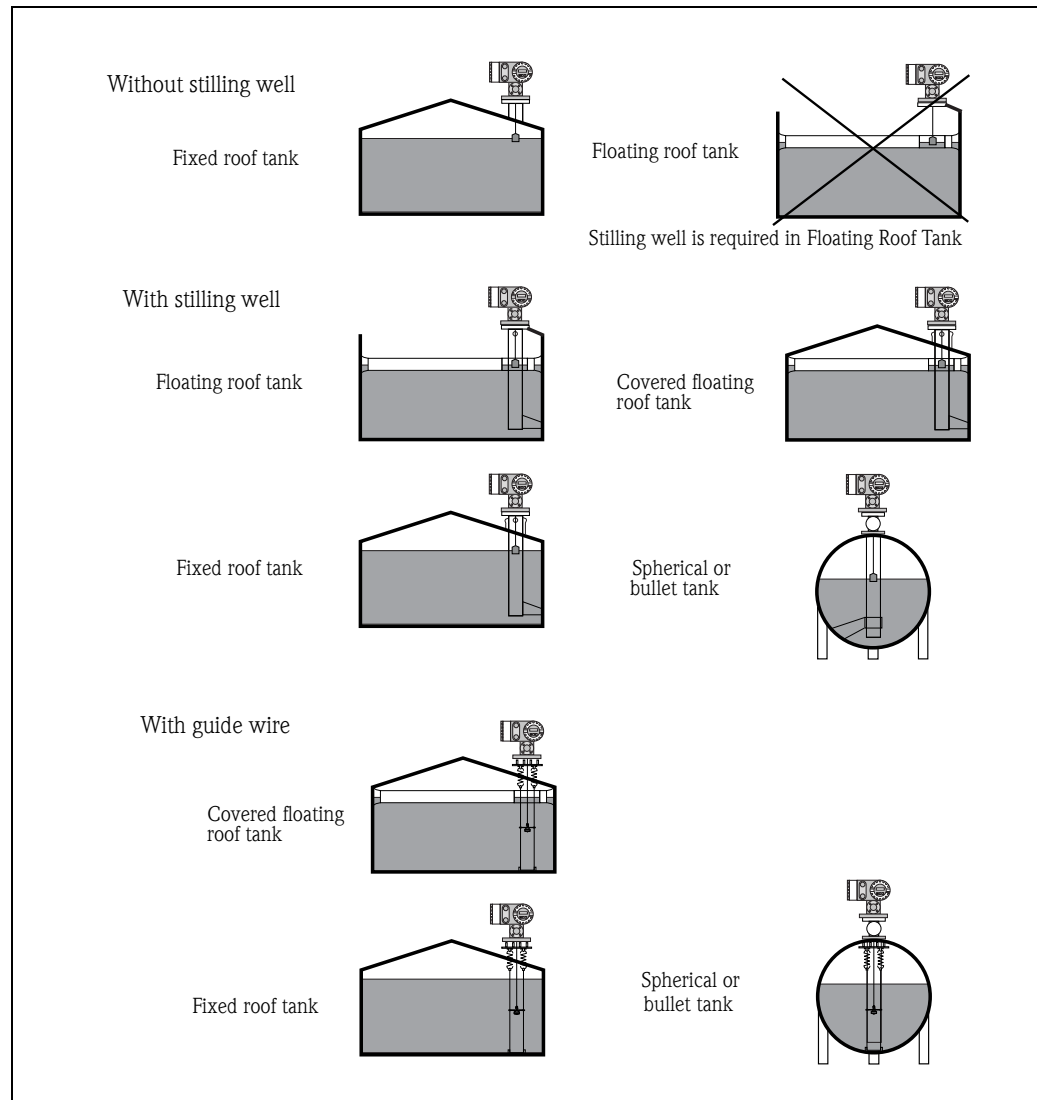

Application for each tank

4.2 Mounting without Guide System

In this case, the Proservo NMS5/7 is mounted on a nozzle of the tank roof without any guide system (see Fig. 9). The mounting preparations require the observance of some recommendations for setting the nozzle and the minimum measuring level.

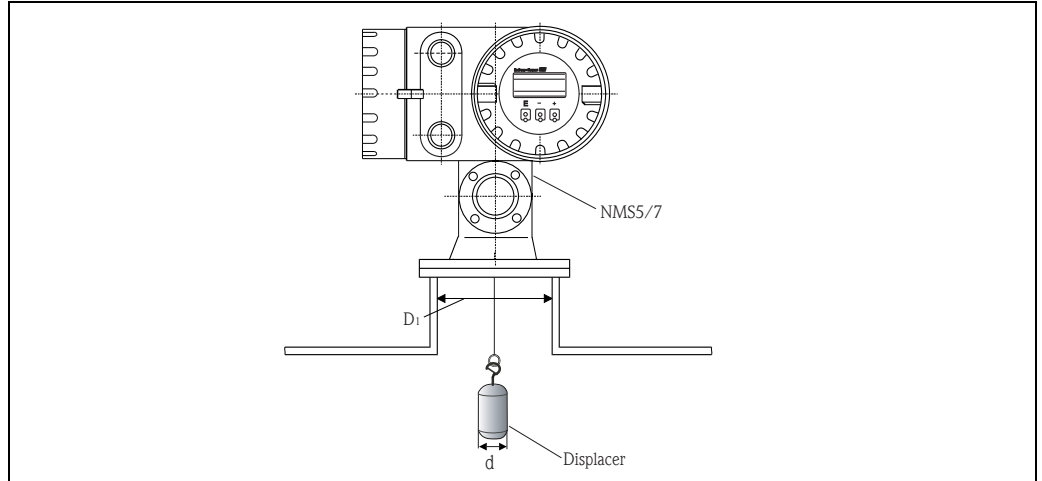

Mounting without guide system

4.3 Mounting with Stilling Well

Pipe diameter

The pipe diameter that is required to protect the measuring wire without disturbing its operation depends on the tank height. The pipe could either be constant diameter, or thinner at its upper part and thicker at its lower part. Fig. 10 shows two examples of the latter case, namely an asymmetric pipe and a concentric pipe.

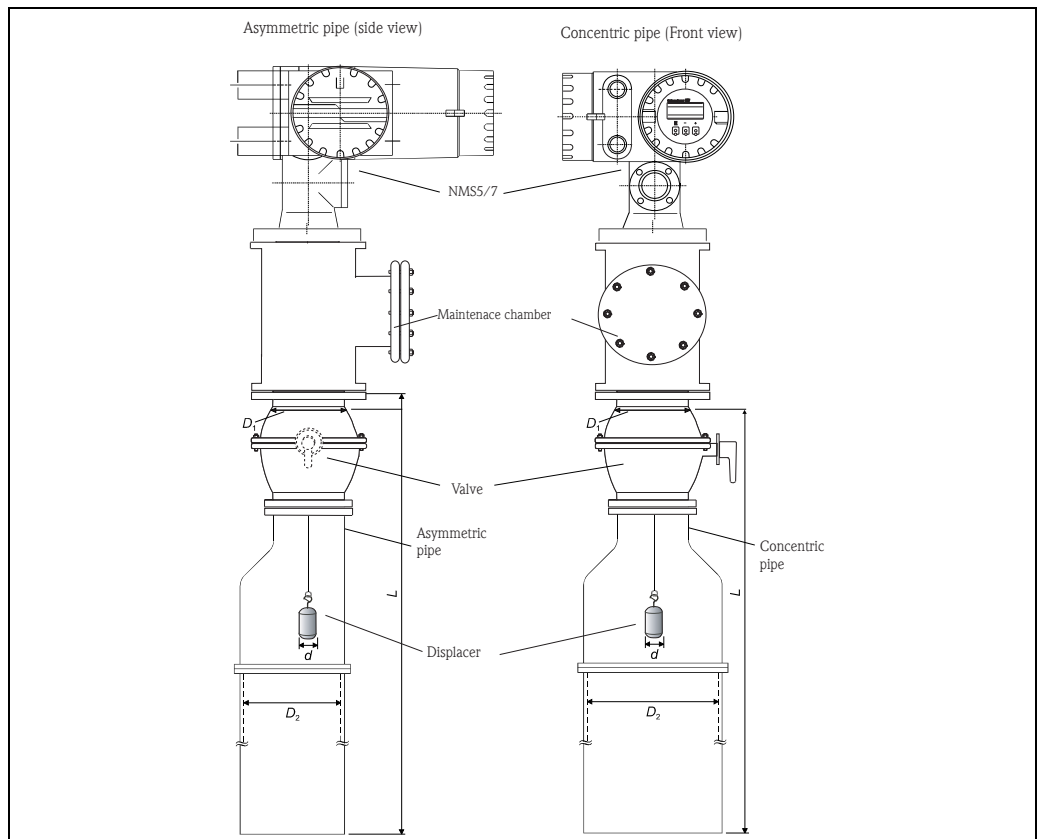

Mounting with stilling well: Asymmetric pipe and connection pipe



Note!

This valve is necessary when mounting the Proservo NMS5/7 onto pressurized liquid tanks. The Proservo NMS5/7 must be mounted on the asymmetric pipe in the direction shown above.

To calculate the required pipe diameters, the formulae below should be used. The variables and constants have the following meanings:

- D₁** Inner diameter of the upper part of the pipe
- D₂** Inner diameter of the lower part of the pipe
- L** Length of the pipe (from the flange of the Proservo NMS5/7 to bottom of the stilling well)
...meters
- v** Deviation of the pipe from the vertical per length
- d** Diameter of the displacer
- e** Lateral shift of the displacer per length due to the groove of the wire drum (max. 33 mm)
- Upper diameter

$$D_1 > d + 10 \text{ mm}$$

where $D_1 > 3"$ should be fulfilled.

- Lower diameter

- Asymmetric pipe

$$D_2 > d + eL + 2vL + 10 \text{ mm}$$

- concentric pipe

$$D_2 > d + 2eL + 2vL + 10 \text{ mm}$$

Recommendations for mounting



Note!

Observe the following recommendations for mounting with stilling well:

- Keep the pipe connection welds smooth.
- While drilling holes into the pipe, keep the interior surface of the holes clear of metal chips and burrs.
- Coat or paint the interior surface of the pipe to avoid rust.
- Keep the pipe as perfectly vertical as possible. Check this by a plumb.
- Install the asymmetric pipe under the valve and fit the centers of the Proservo and the valve.
- Set the center of the lower part of the asymmetric pipe to the direction of the displacer motion.
- Observe recommendations as per API MPMS chapter 3.1B.
- Confirm grounding between NMS Proservo and tank nozzle.

4.4 Mounting with Guide Wire

It is also possible to guide the displacer by a guide wire to prevent lateral motion.

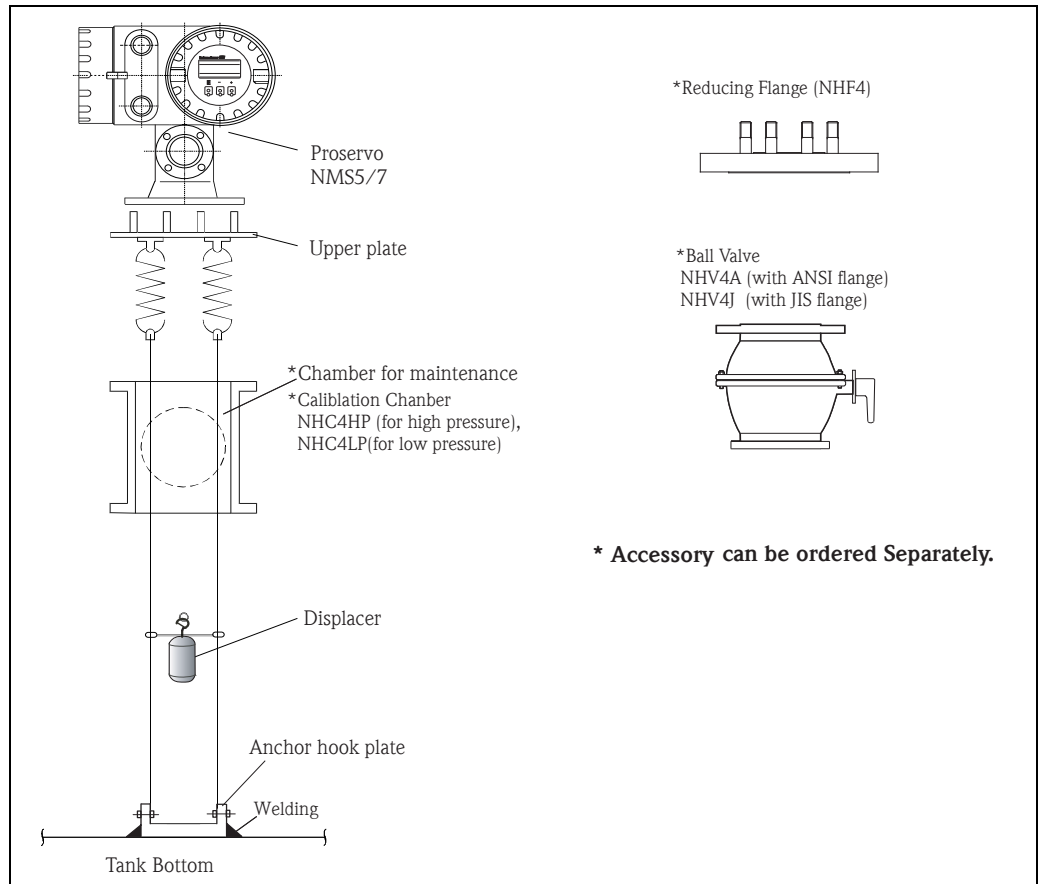

Mounting with Guide Wire

4.4.1 Tank type

Fixed roof Tank with stilling well

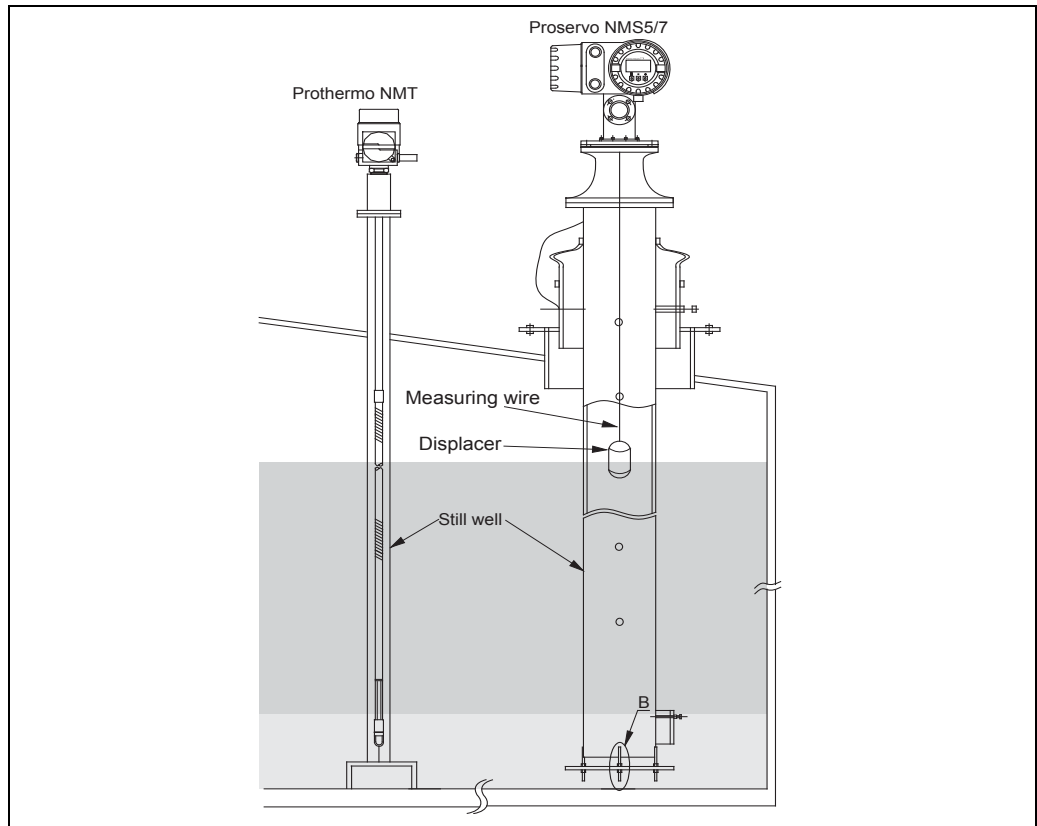

High pressure tank with stilling well and ball valve

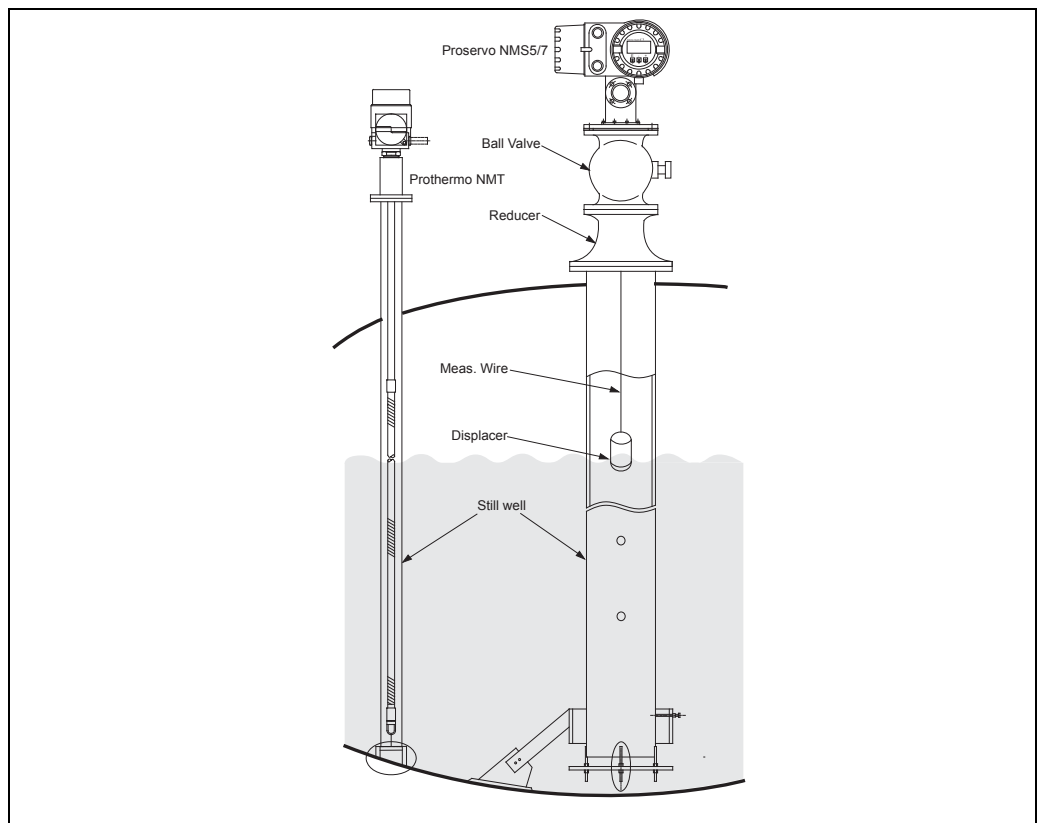

Floating roof tank and /or covered floating roof Tank

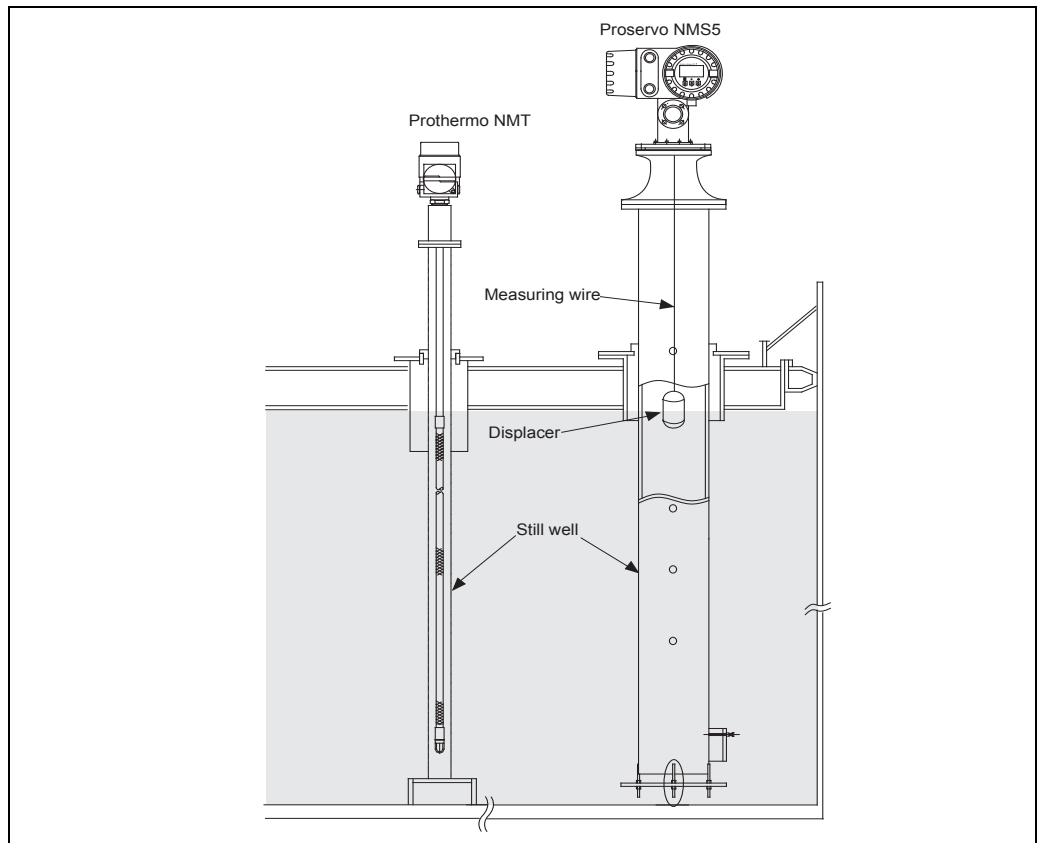

Note!

When the proservo is installed on Floating roof tank, be sure to use stiling Well.

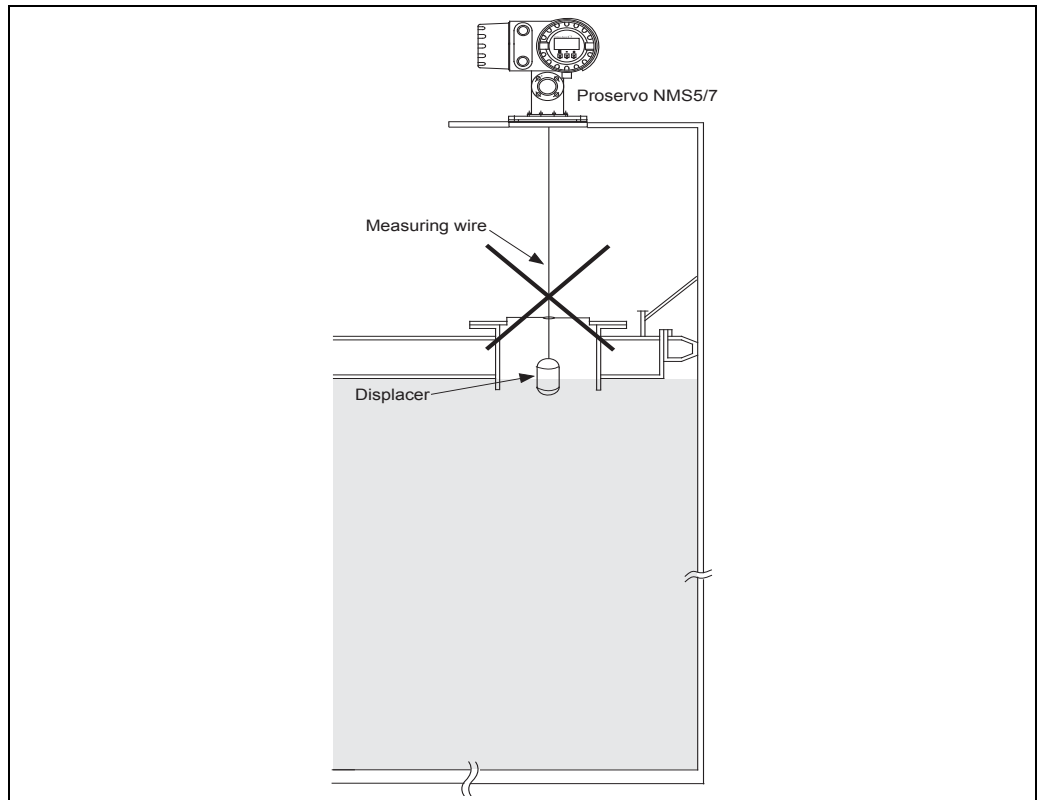

4.5 Mounting Preparations

4.5.1 Flange

The mounting flange should be prepared before mounting the Proservo NMS5/7 to the tank. The flange size and the rating of the Proservo NMS5/7 depend on the customer's specifications.

Note!



- Check the flange size which is on the surface of the Proservo NMS5/7.
- Install the flange on the top of the tank. Its deviation from the horizontal plane should not exceed ± 1 deg.
- For mounting the Proservo NMS5/7 onto a longer nozzle, make sure that the displacer does not touch the interior surface because of the vertical inclination of the nozzle.

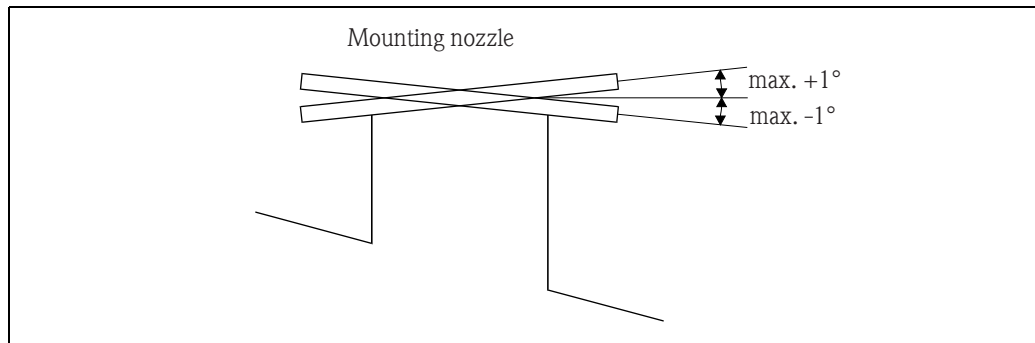

Allowable inclination of the mounting flange

Note!



If the Proservo is installed without guide system, then consider the following recommendations:

- Set the mounting nozzle in the sector between 45 and 90 deg (or -45 and -90 deg.) apart from the inlet pipe of the tank. This will prevent heavy swing of the displacer caused by wave or turbulence of the inlet liquid.
- Set the mounting nozzle at least 500mm away from the tank wall. This will ensure that the measurement is not influenced by changes of the ambient temperature.
- Set the minimum measuring level at least 500mm above the top of the inlet pipe. This will protect the displacer from direct flow of the inlet liquid.

If it is not possible to install the Proservo NMS5/7 in such place, then we recommend mounting with guide system. Consult E+H Service for further information.

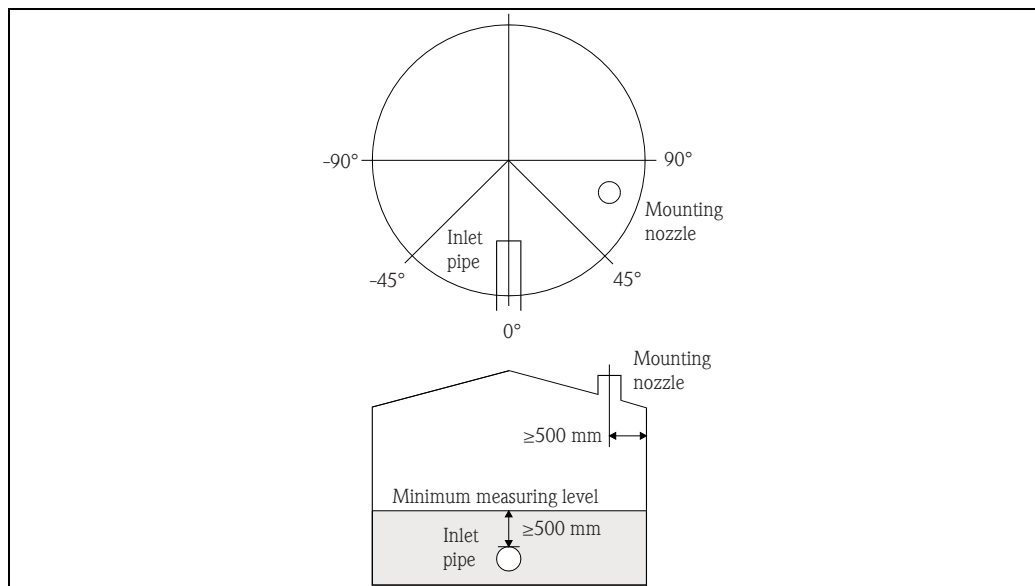

Recommended setting of mounting nozzle and minimum measuring level

**Warning!**

Before pouring liquid into the tank, make sure that the flow from the inlet pipe cannot hit the displacer directly.

During discharging the tank, avoid suction of the displacer to the outlet pipe.

4.6 Electrostatic Charge

**Note!**

- If the liquid measured by the Proservo NMS5/7 has a conductivity of less than 10^{-8} s/cm, it is quasi-nonconductive. In that case, we recommend to use a stilling well or guide wire made of conductive material. This will release the electrostatic charge on the liquid surface.

4.7 Installation for Wire Drum and displacer

Proservo is delivered with 2 options for displacer mounting.

- "All-in-one" with displacer mounted on the measuring wire.
in this case, follow the instructions for removing the packing, which are attached to Proservo.

- Displacer shipped separately

In this case, it is necessary to install the displacer on the measuring wire inside Proservo.
In either case, follow the instructions below.

4.7.1 All-in-one

They are protected by some packaging materials, so please remove them before mounting the NMS5/7.

Packaging material desinstallation procedure

Step	Working	Notes
1	<ul style="list-style-type: none"> ■ Hold the gauge with the flange horizontal ■ Cut a fixing bands. ■ Remove displacer holder 	<ul style="list-style-type: none"> ■ Do not tilt the gauge after removing displacer holder.
2	<ul style="list-style-type: none"> ■ Mount the NMS on nozzle . 	<ul style="list-style-type: none"> ■ Check that the measuring wire hangs vertically. ■ Check that there are no kinks or any abnormality from calibration window.
3	<ul style="list-style-type: none"> ■ Remove a cover for drum housing. ■ Loosen two screws on wire drum holder, remove the holder. (see below drawing) 	<ul style="list-style-type: none"> ■ Be careful not to lose O-ring and fixed bolts for cover for drum housing.
4	<ul style="list-style-type: none"> ■ Remove tape on wire drum slowly. 	<ul style="list-style-type: none"> ■ Remove the tape using your hands not to cause damage to wire drum ■ Check that measuring wire is wrapped in the grooves. ■ If not, rewind the wire correctly in the groove.
5	<ul style="list-style-type: none"> ■ Install the cover for drum housing 	<ul style="list-style-type: none"> ■ Check that O-ring is fitted in groove.
6	<ul style="list-style-type: none"> ■ Turn on of NMS main power and confirm "STOP" condition and level is "16050 ~ 16060 mm". ■ Put command of "LEVEL" and then "STOP" until level is lower than 16000 mm, i.e.) around 15950 mm. ■ Set "UP" command and displacer will stop automatically at 16000 mm. ■ Set "STOP" command. 	

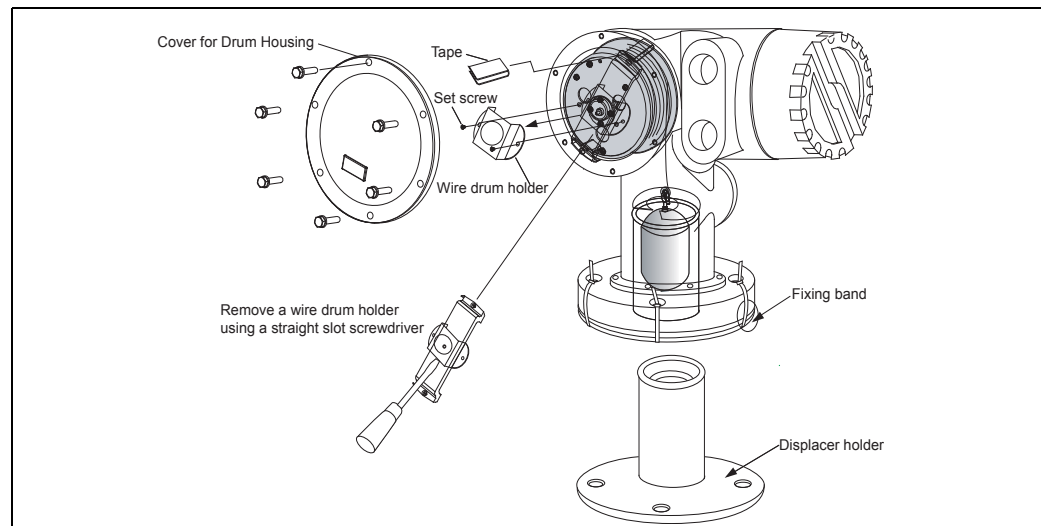

4.7.2 Displacer shipped separately

It is necessary to install the displacer on the measuring wire inside Proservo.

Procedure A : Install a displacer before installing Proservo on tank

Drawing	Working	Notes
	<ul style="list-style-type: none"> Put NMS on blocks or a pedestal (see drawing). Check that there is enough space under the NMS. 	<ul style="list-style-type: none"> Be careful not to drop NMS.
	<ul style="list-style-type: none"> Remove M8 bolts on cover for wire drum (see drawing). Remove cover and bracket for wire drum. Remove wire drum from drum housing. Remove tape that secures measuring wire. Insert wire drum back into drum housing and set bracket. 	<ul style="list-style-type: none"> Please handle the measuring wire with care.
	<ul style="list-style-type: none"> Rotate wire drum in clockwise direction until measuring wire ring appears outside the flange. Hook displacer into ring on measuring wire. Secure displacer to measuring wire with securing wire (see drawing). Rotate wire drum in counter-clockwise direction until measuring wire ring appears in calibration window. 	<ul style="list-style-type: none"> Wire drum rotates every one-fifth revolution. Displacer moves over 300mm each one revolution.
	<ul style="list-style-type: none"> Install NMS on nozzle on tank top. Check that displacer do not touch a nozzle inside. Close the drum housing. 	<ul style="list-style-type: none"> Check that measuring wire is wrapped in the grooves. If not, rewind the wire correctly in the grooves.

4.7.3 Displacer shipped separately (Diameter 50mm displacer)

In case of dia. 50mm displacer, it is possible to install the displacer from calibration window.

Procedure B : Install a displacer after installing Proservo on a tank

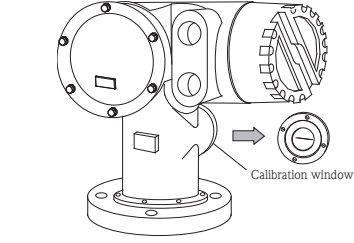
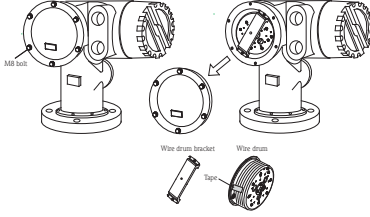
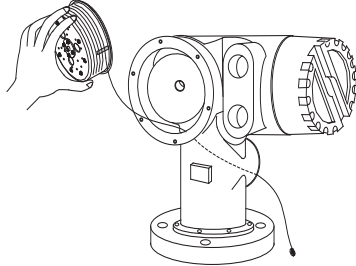
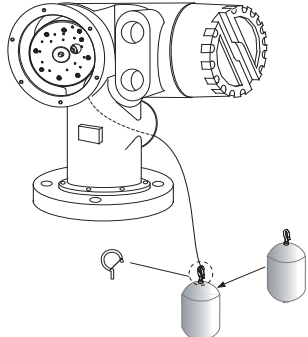
Drawing	Working	Notes
 <p>Calibration window</p>	<ul style="list-style-type: none"> Remove cover for calibration window. 	<ul style="list-style-type: none"> Be careful not to kink and damage measuring wire.
 <p>M8 bolt Wire drum bracket Wire drum Tape</p>	<ul style="list-style-type: none"> Remove M8 bolts on cover for wire drum (see drawing). Remove cover and bracket for wire drum. Remove wire drum from drum housing. Remove tape that secures measuring wire. 	<ul style="list-style-type: none"> Please handle the measuring wire with care.
	<ul style="list-style-type: none"> Hold wire drum in one hand and drop measuring wire down about 50 cm. Secure wire on wire drum with tape, temporarily. Insert ring on measuring wire into wire drum housing and pull the ring and measuring wire ring out from calibration window. 	<ul style="list-style-type: none"> Please handle the measuring wire with care.
	<ul style="list-style-type: none"> Insert wire drum back into drum housing temporarily. Hook displacer into ring on measuring wire. Secure displacer to measuring wire with securing wire (see drawing). 	<ul style="list-style-type: none"> Please handle the measuring wire with care. It may cause damage by kink

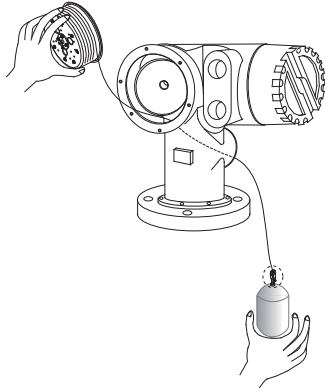
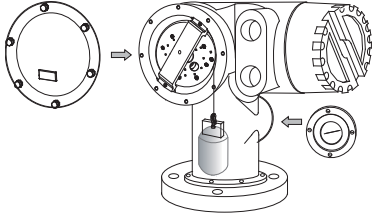
Drawing	Working	Notes
	<ul style="list-style-type: none"> ■ Hold wire drum and displacer in hands. ■ Remove wire drum from wire drum housing and drop measuring wire down about 50 cm. ■ Hold wire drum up and place displacer into calibration window ■ Hold one hand (displacer) at center of calibration window. ■ Hold other hand (wire drum) up and add tension to measuring-wire not to drop displacer down rapidly. 	<ul style="list-style-type: none"> ■ Wire drum rotates every one-fifth revolution. ■ Displacer move over 300mm each one revolution.
	<ul style="list-style-type: none"> ■ Release your hand from displacer. ■ Remove tape on wire drum and insert wire drum into drum housing . ■ Set wire drum bracket. ■ Rotate wire drum with your hand couple of times and check that displacer does not touch nozzle inside by hoisting displacer. ■ Pull ring on measuring wire up to calibration window. ■ Close wire drum housing and calibration window. 	<ul style="list-style-type: none"> ■ Check that measuring wire is wrapped along a groove rightly before turning on power. ■ If not, rewwind the wire correctly in the grooves.

5 Wiring

5.1 Wiring Connection

The electrical connections of the Proservo NMS5/7 are shown in Figs. 14-19.

Note!



The power supply cable should have the following specifications:

- PVC, PE, or equivalently isolated
- 600 V insulation voltage or equivalent.

The size of the core will be defined by core resistance, voltage drop, and required power consumption. The maximum power consumption of the Proservo NMS5/7 is 50 VA.

Caution!



- Connect the ground line to the ground terminal inside or outside the terminal box.
- Use cable and wire of sufficient and appropriate size and length, to make a solid connection at each terminal required.

Warning!



Do not stretch cable and wires. Doing so may lead to failure, loss of function, and/or damage to the device and facility.

Trim cable and wire to appropriate length. Do not leave excess cable and wire in the electrical compartment. Doing so may lead to failure, loss of function, and /or damage to the device and facility.

5.2 Terminal assignment

5.2.1 EEx d IIB

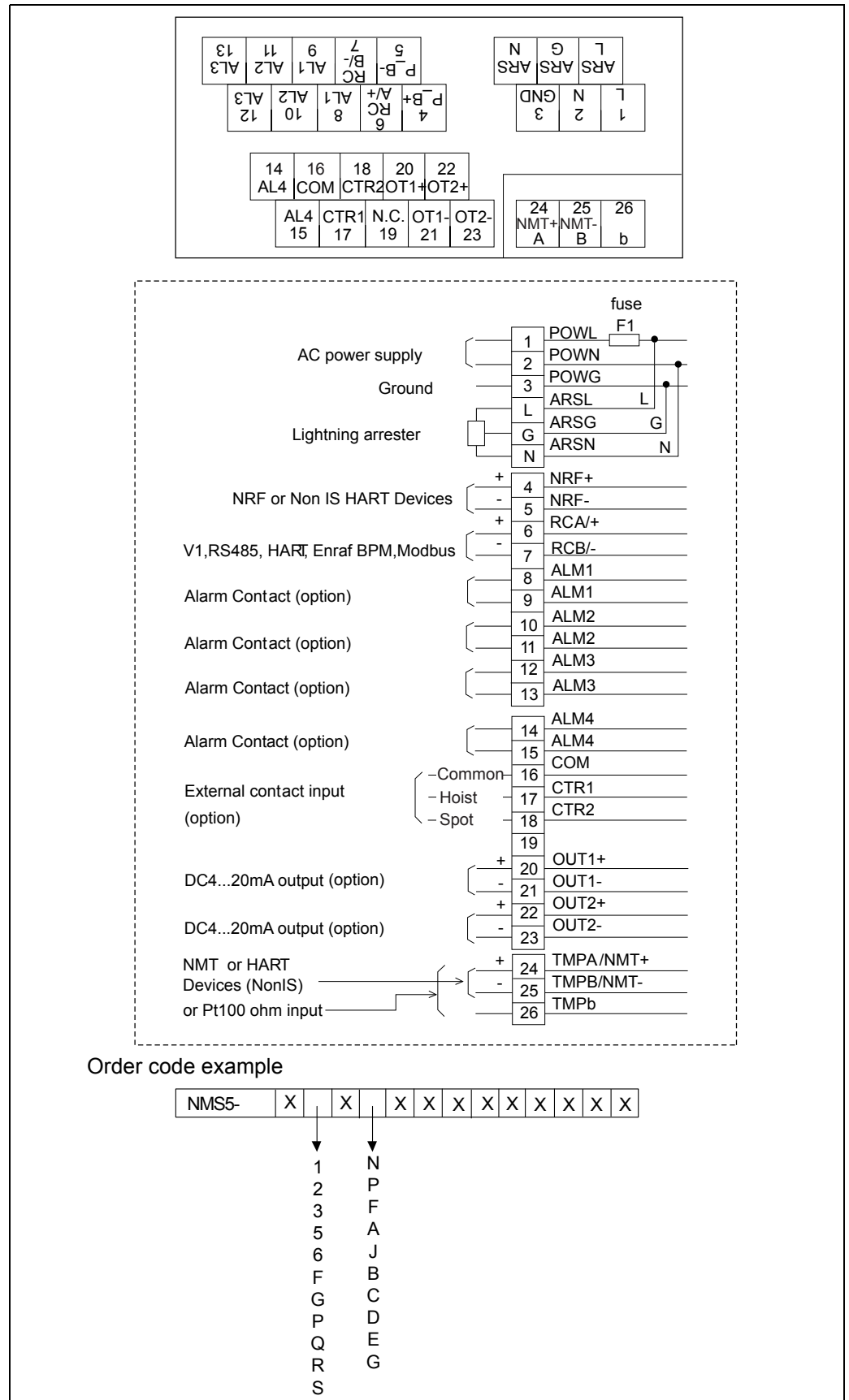

Electrical connection of the Proservo NMS5

5.2.2 EEx d[ia] IIB

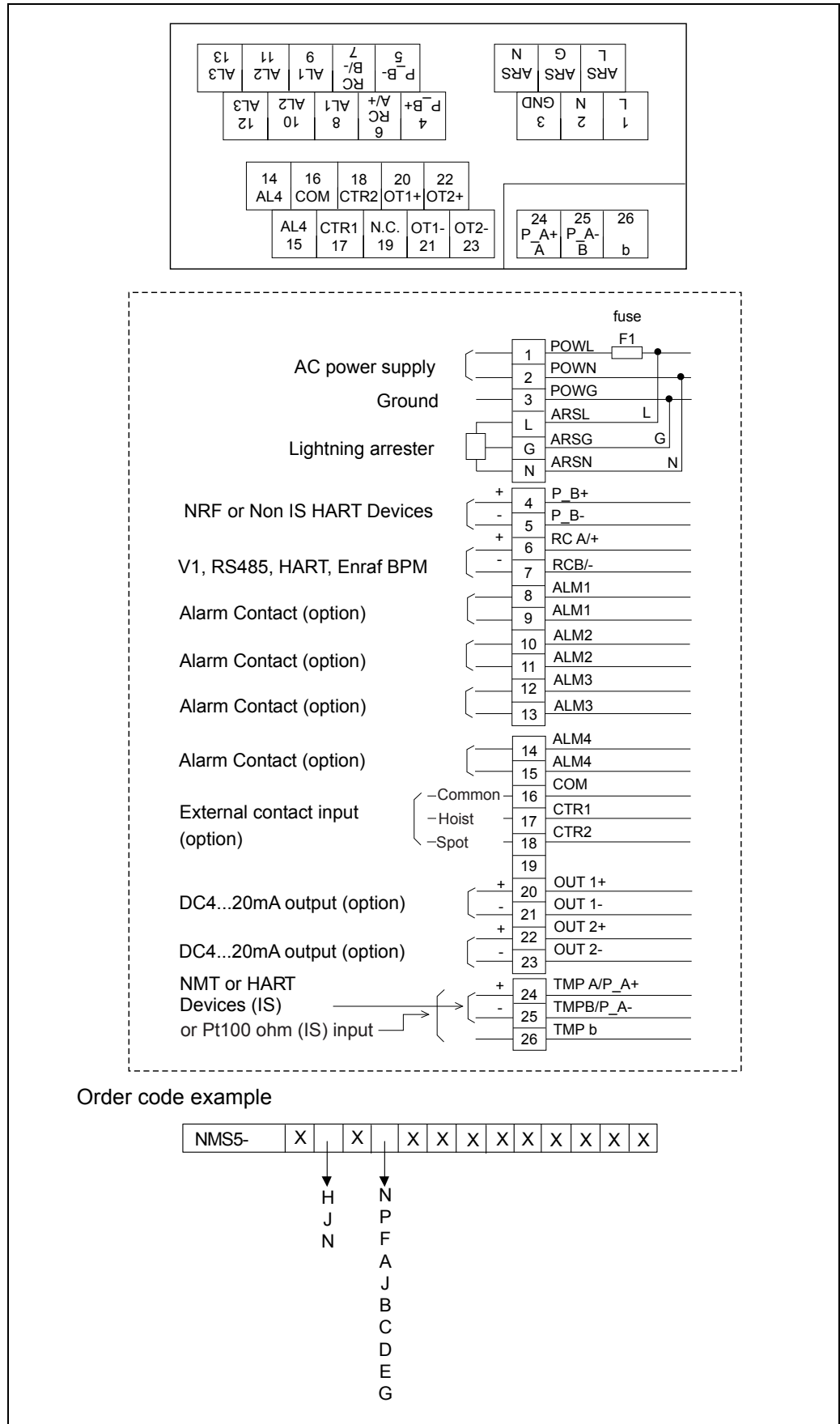

Electrical connection the Proservo NMS5 with IS HART connection

5.2.3 Whessoe Matic 550 (WM550) Protocol with Non-IS Certificates

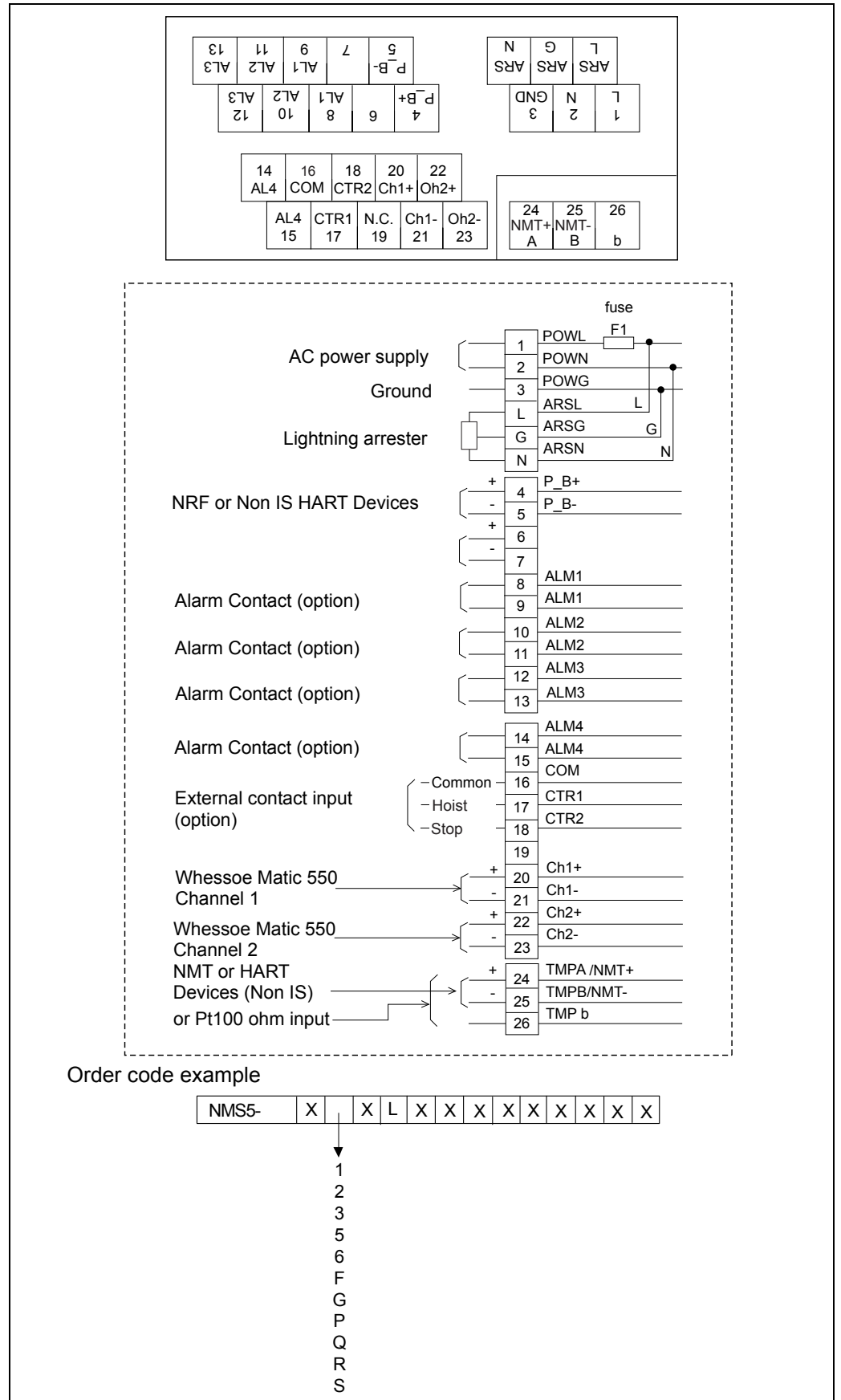

Electrical connection of the Proservo NMS5 with WM550 Protocol with Non-IS HART connection.

5.2.4 Whessoe Matic 550 (WM550) Protocol with Intrinsic Safety Certificates

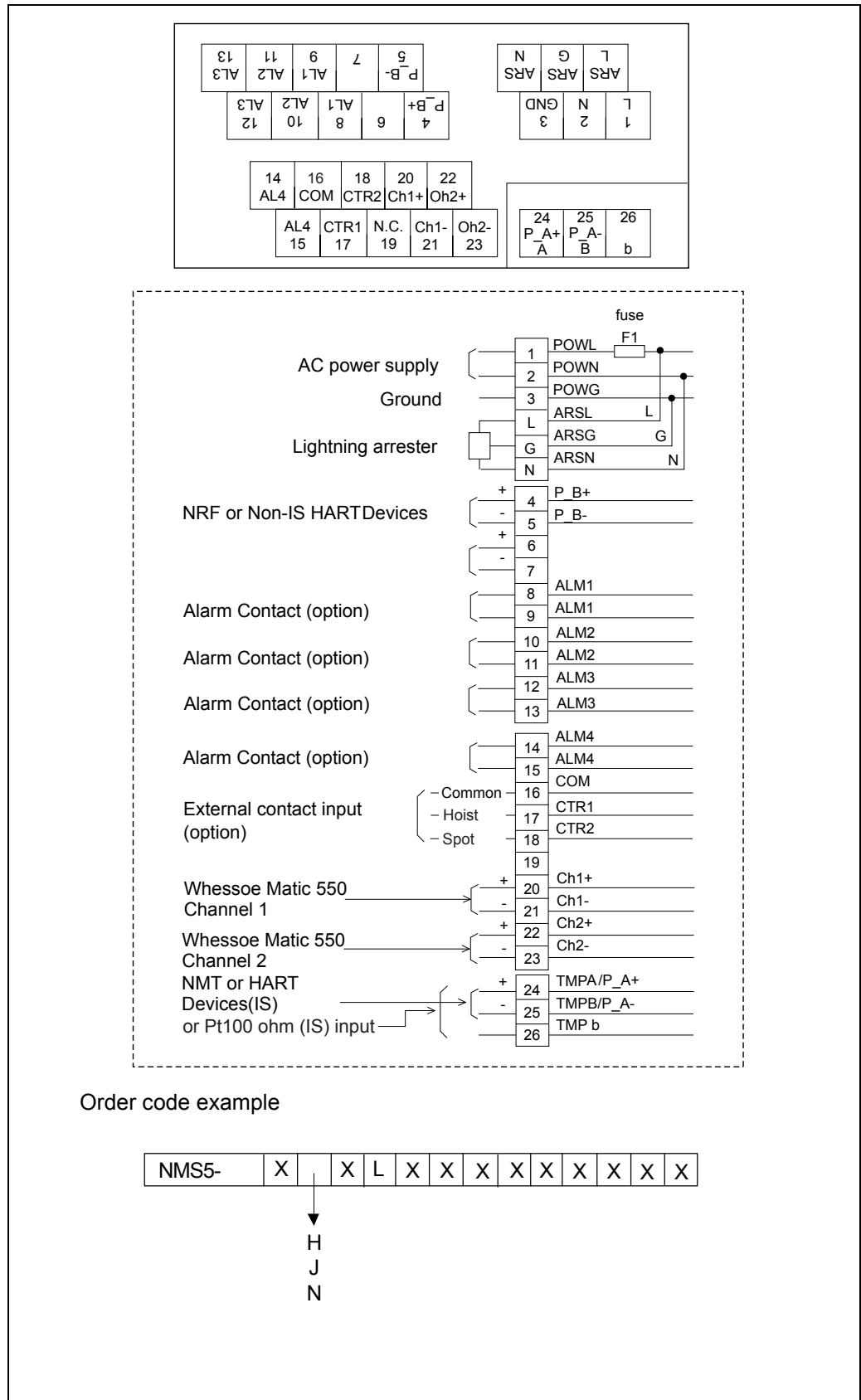

Electrical connection of the Proservo NMS5 with WM550 protocol with IS HART connection

5.2.5 Mark/Space (M/S) Protocol with Non-IS Certificates

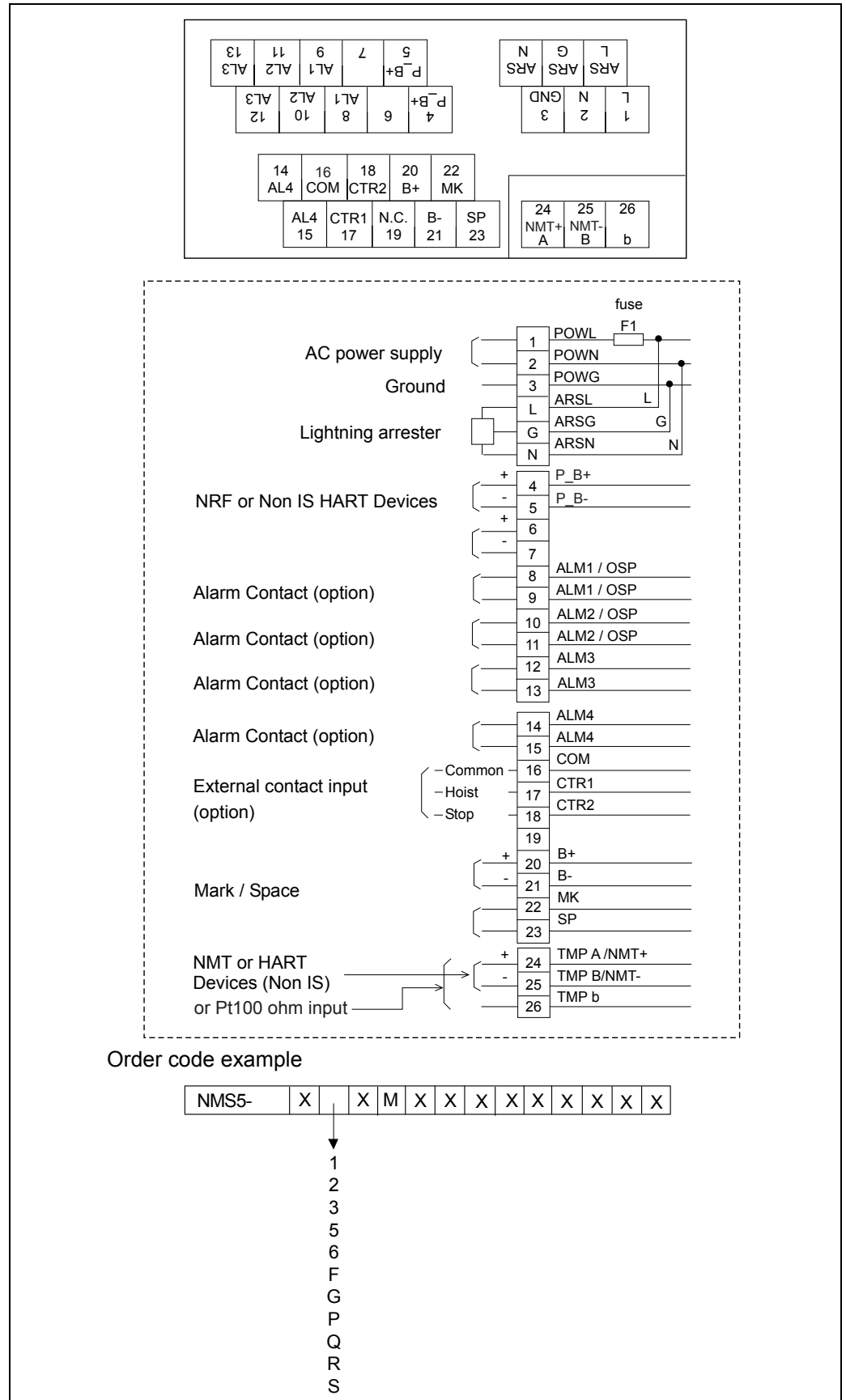

Electrical connection of the Proservo NMS5 with M/S Protocol with Non-IS HART connection

5.2.6 Mark/Space (M/S) Protocol with Intrinsic Safety Certificates

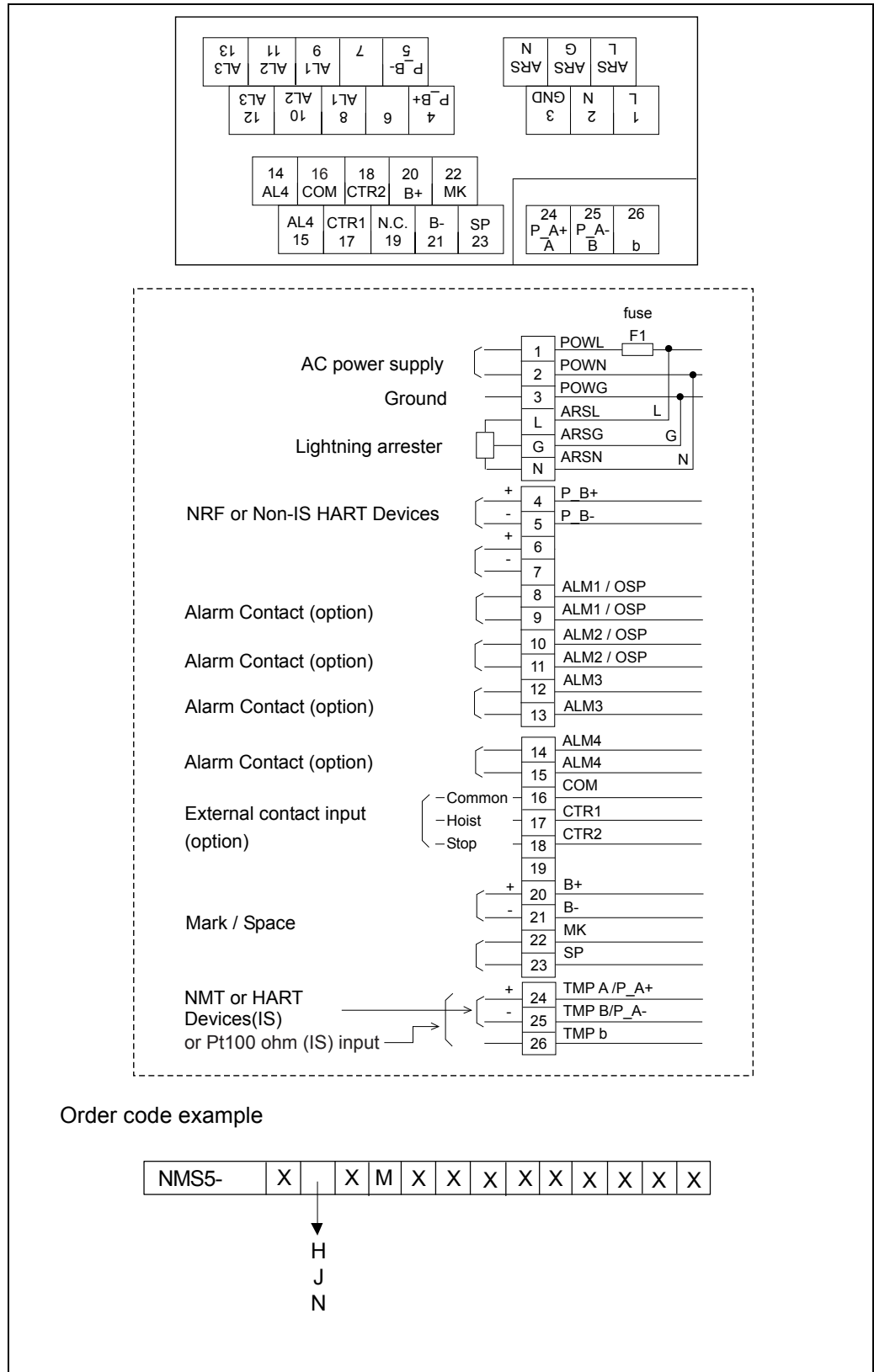

Electrical connection of the Proservo NMS5 with M/S Protocol with IS HART connection

The following table is the logic, if you use external contact input (Hoist-CTR1)(Stop-CTR2).

CTR 1	CTR 2	OPERATION
OFF	OFF	LEVEL
ON	OFF	HOIST
OFF	ON	STOP
ON	ON	INTERFACE

5.2.7 Input and output

Input

- Contact Switch
- HART
- Pt 100

Output

- V1
- WM550
- M/S
- ENRAF BPM
- MODBUS
- HART
- ANALOG 4-20mA
- Overspill Protection (OSP)



Warning!

- The cable used for input and/or output must be more than 24 AWG screened or steel armored. A twisted pair is required for the HART and/or RS 485 signal.
- Two or three cores for mains, two cores for digital output, and two cores for HART input are normally used for the cabling of the Proservo NMS5/7. The instrument has max. four cable entries.
- Before you place an order for the Proservo NMS5/7, please check the cable size and the number of cables.

5.2.8 Cable Gland

If you do not use all the cable entries, then take out unnecessary glands and install a threaded plug of prevent intrusion of water.

5.3 Temperature input system

There are two types of temperature input method and two types of Ex protection system as EEx d or EEx [ia] in the Proservo NMS5/7 series

5.3.1 EEx d HART input

These NMS 5/7 series have EEx d HART input to communicate with EEx d NMT53x series temperature sensor or auxiliary EEx d HART sensor.

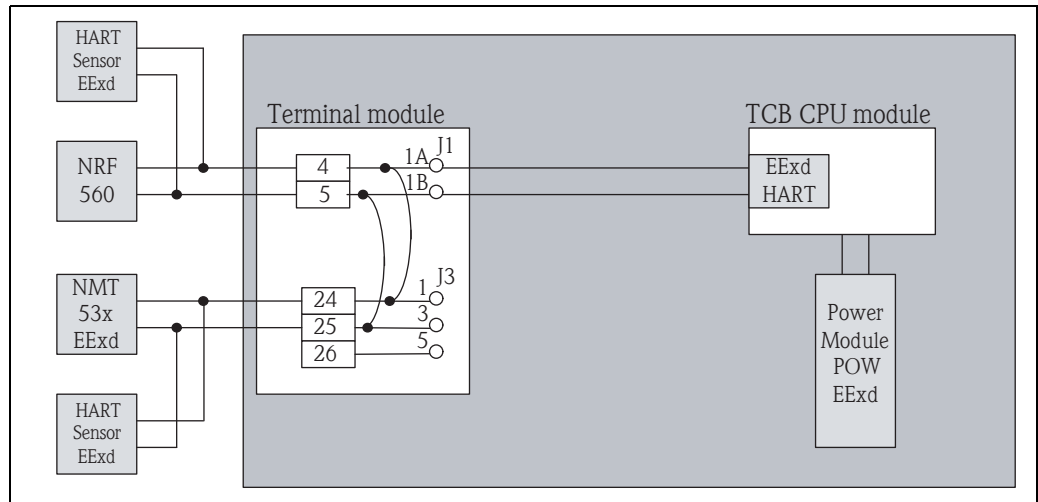

5.3.2 EEx d Pt100 Spot Temperature input

These NMS 5/7 series have EEx d Pt100 temperature input connected directly from EEx d pt100 sensor and EEx d HART input to communicate with auxiliary EEx d HART sensor.

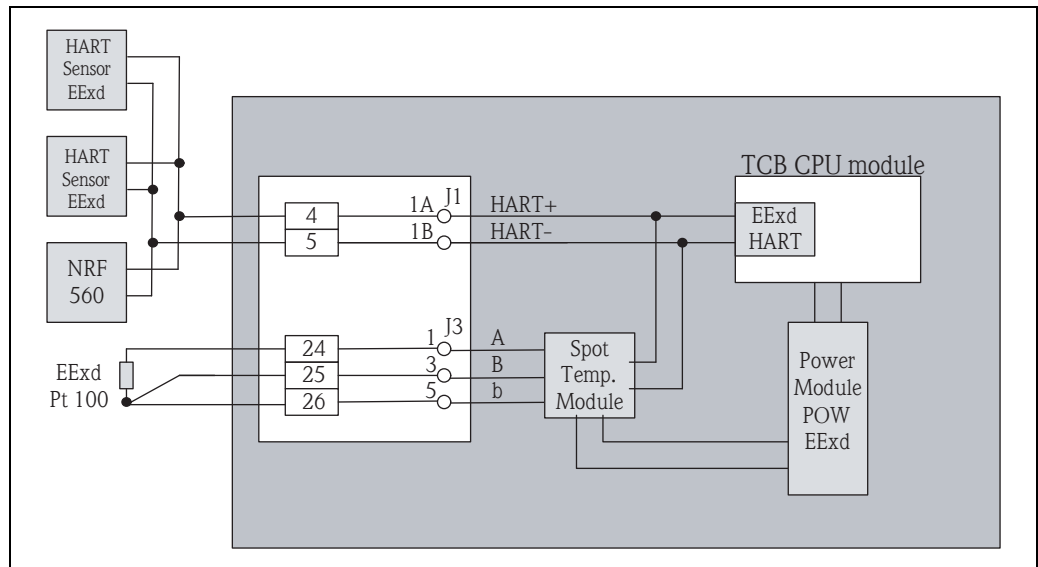

5.3.3 EEx ia HART input

These NMS 5/7 series have EEx ia HART input to communicate to EEx ia NMT 53x series temperature sensor or auxiliary EEx ia HART sensor and EEx d input to communicate with auxiliary EEx d HART sensor.

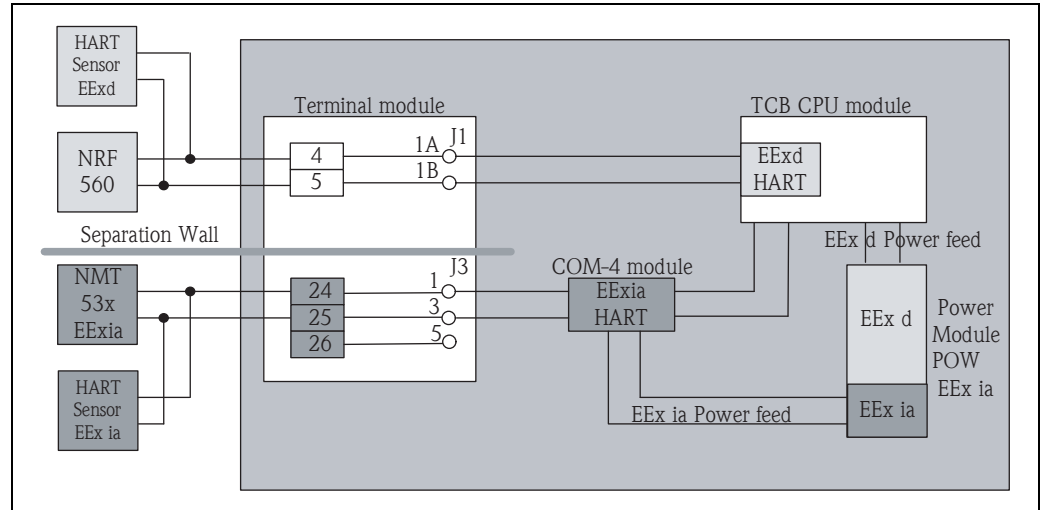

5.3.4 EEx ia Pt100 Spot temperature input

These NMS 5/7 series have EEx ia Pt100 temperature input connected directly from EEx ia Pt100 sensor and EEx d HART input to communicate with auxiliary EEx d HART sensor.

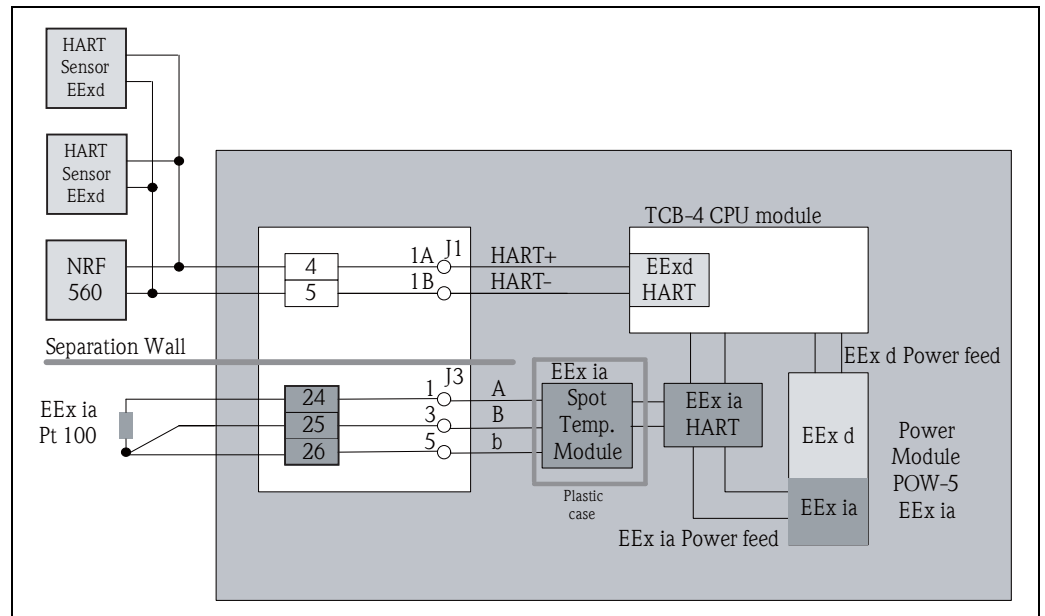

6 Operation

6.1 Touch Control and Programming Matrix

6.1.1 Display and Operating Elements

Display

During normal operation, Proservo NMS5/7 has an illuminated LCD that shows the level, the temperature, and the status of the device on the "HOME" position.

For the display of the other data and the programming of the parameters for operation, the Proservo NMS5/7 uses a convenient programming matrix.

Operating elements

The Proservo NMS5/7 is operated by three visual operating elements, namely the keys "E", "+", and "-". They are actuated when the appropriate field on the protective glass of the front is touched with the finger ("touch control"). The corresponding transmitting and receiving diodes are not affected by external influences, e.g. direct sunlight. The software and hardware installed in the Proservo NMS5/7 rule out any malfunction that may be caused in this way. Even in explosive hazardous areas, the explosion-proof housing of the touch control ensures a safe access to the data.

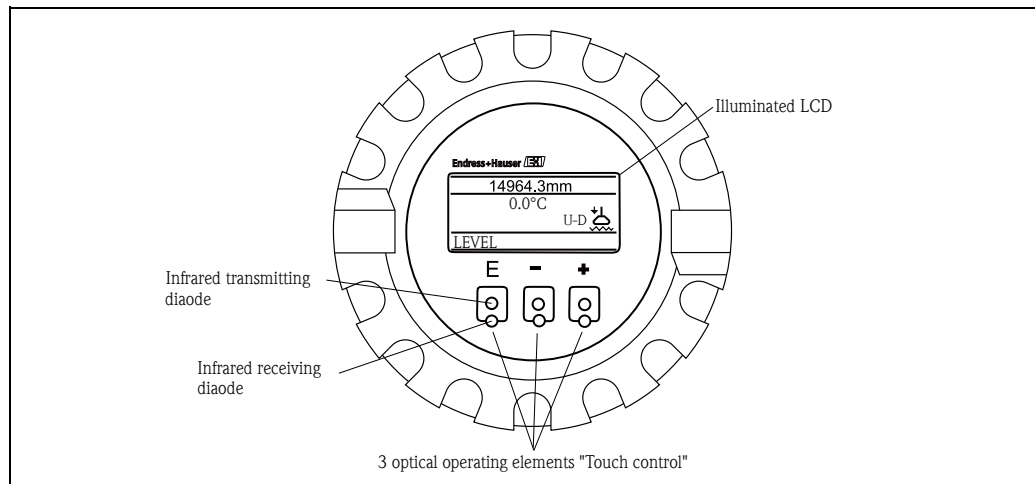

Display

6.1.2 Functions of the Operating Elements

The programming matrix consists of matrix groups, namely one "static" matrix and additional "dynamic" matrices. They are described in detail in Section 11. The individual matrix groups, function groups, and functions within the programming matrix can be selected by alternately touching the operating elements. This is explained Figs. 20, 21 and 22.

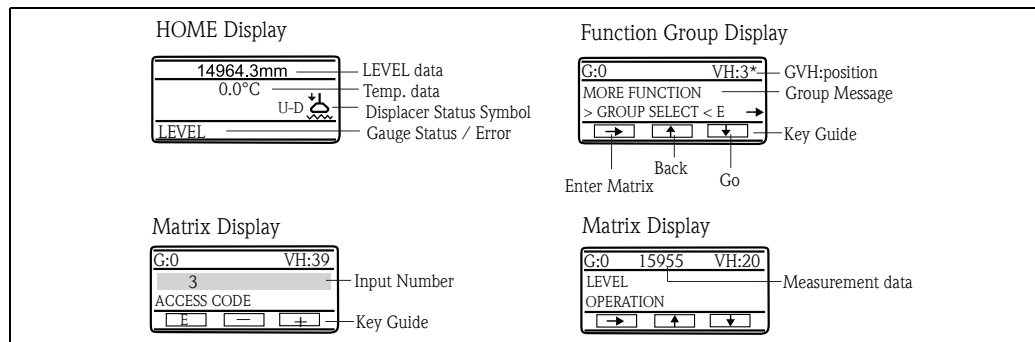

Displays

Matrix Construction

		0	1	2	3	4	5	6	7	8	9
Measured Value 1	0										
Measured Value 2	1										
Operation	2										
More Function	3	Calibration									
Level Data	4										
Calibration	5										
Adjustment	6										
Auto Wire Calib.	7										
Auto Calib. Displ.	8										
Display	9										

		0	1	2	3	4	5	6	7	8	9
Measured Value 1	0										
Measured Value 2	1										
Operation	2										
More Function	3	Device Data									
Contact Output	4										
Analog Out	5										
parts Data	6										
Input Signal	7										
Communication	8										
Status	9										

		0	1	2	3	4	5	6	7	8	9
Measured Value 1	0										
Measured Value 2	1										
Operation	2										
More Function	3	Service									
Meas. Wire & Drum	4										
Gauge data	5										
System Data	6										
Service	7										
Sensor Value	8										
Sensor Data	9										

		0	1	2	3	4	5	6	7	8	9
Measured Value 1	0										
Measured Value 2	1										
Operation	2										
More Function	3	Temperature									
Temperature Data	4										
Element Temp.	5										
Element Position	6										
NMT Adjustment	7										
Set Data NMT	8										
Device Data	9										

		0	1	2	3	4	5	6	7	8	9
Measured Value 1	0										
Measured Value 2	1										
Operation	2										
More Function	3	HART Dev (1)									
Measured Value	4										
P.V. Setting	5										
Sensor Specific	6										
Alarm	7										
Self Diagnostic	8										
Device Data	9										

		0	1	2	3	4	5	6	7	8	9
Measured Value 1	0										
Measured Value 2	1										
Operation	2										
More Function	3	HART Dev (2)									
Measured Value	4										
P.V. Setting	5										
Sensor Specific	6										
Alarm	7										
Self Diagnostic	8										
Device Data	9										

		0	1	2	3	4	5	6	7	8	9
Measured Value 1	0										
Measured Value 2	1										
Operation	2										
More Function	3	Adjust Sensor									
Adjust Sensor	4										
HART Error Rate	5										
Unit	6										
HART Line	7										
Interface Adjust	8										
	9										



		0	1	2	3	4	5	6	7	8	9
Measured Value 1	0										
Measured Value 2	1										
Operation	2										
More Function	3	Tank Profile									
Profile Operation	4										
Status/Data	5										
Density 1-10	6										
Density 11-16	7										
Position 1-10	8										
Position 11-16	9										

		0	1	2	3	4	5	6	7	8	9
Measured Value 1	0										
Measured Value 2	1										
Operation	2										
More Function	3	Interface Profile									
	4										
Status/Data	5										
Density 1-10	6										
Density 11-16	7										
Position 1-10	8										
Position 11-16	9										

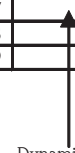
Static Matrix Dynamic Matrix



Matrix construction

Key	Functions
	<ul style="list-style-type: none"> Access to the programming matrix (touching the key for more than 3 sec.) Return to the HOME position (touching the key for more than 3 sec.) Moving horizontally within a function group to select functions. Saving parameters or access code.
 	<ul style="list-style-type: none"> Moving vertically to select function groups Selecting or setting parameters Setting access code

 **Note!** The LCD will return to the HOME position if no key is touched for more than 20 min. Digits are incremented or decremented by + or -, respectively. If you touch + or - continuously, then the minimum digit will change first. After one cycle of the minimum, the second minimum will change. After one cycle of the second follows the third minimum, and so on. If you take off your finger from the touch control, then the procedure will start again from the minimum digit (Analogy of mechanical counter).

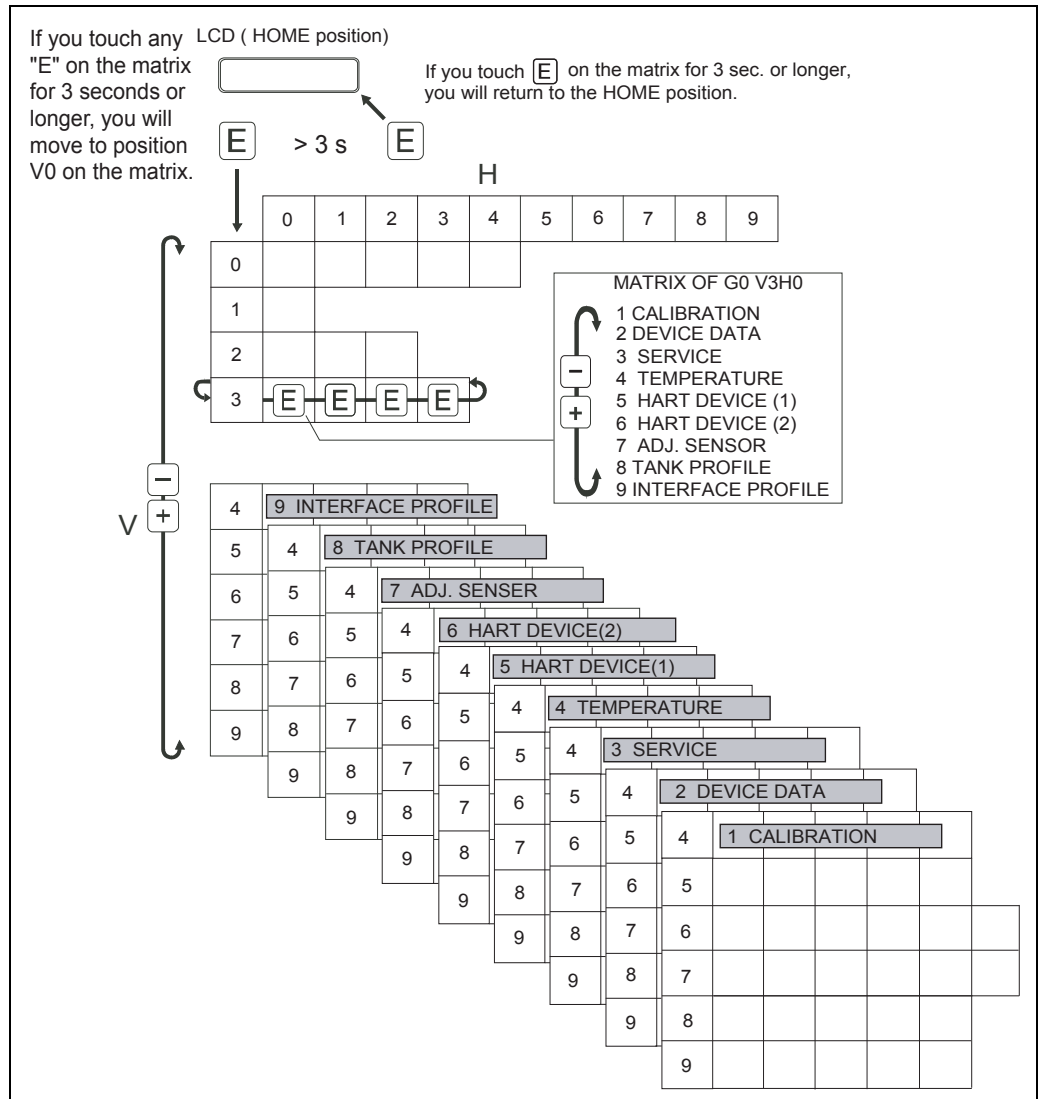

Selection matrix groups, function groups, and functions with the programming matrix

6.2 HOME Position

After turning on the power supply, the LCD first shows the current data on the HOME position.

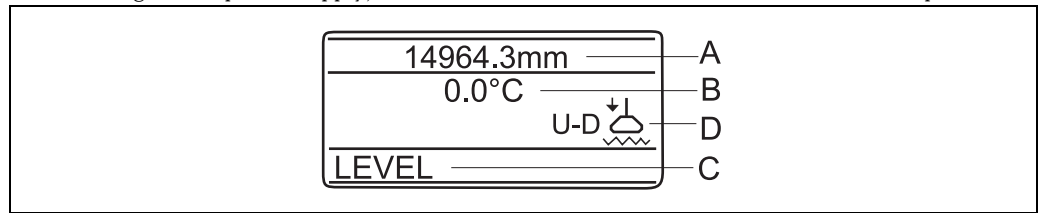







HOME position

The letters A, B, C and D stand for the areas where information on measured values and status of the device are displayed:

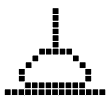
Area	Information
A	Current level
B	Current temperature
C	Gauge status
D	Displacer status

The meanings of gauge status and displacer status are explained in the following tables.

Gauge status	Meaning
G - RE	The displacer is resting at the reference position.
UP	The UP command has been given.
STOP	The STOP command has been given.
LIQU	The Proservo NMS5/7 is measuring the surface level.
U - IF	The Proservo NMS5/7 is measuring the upper interface level.
LIF	The Proservo NMS5/7 is measuring the lower interface level.
BOTM	The Proservo NMS5/7 is measuring the tank bottom level.
U - DE	The Proservo NMS5/7 is measuring the upper liquid density.
M - DE	The Proservo NMS5/7 is measuring the middle liquid density.
B - DE	The Proservo NMS5/7 is measuring the bottom liquid density.
CAN	The RELE.OVER TENS command has been given.
TEAC	The Proservo NMS5/7 is carrying out calibration.
blank	The Proservo NMS5/7 cannot detect any level.

Displacer status	Symbol	Meaning
BAL		Balance The displacer is resting on the liquid surface or interface and in balanced status.
T - B		Temporary Balance Automatic weight calibration is being carried out.
U - U		Unbalance Up The displacer is being hoisted and in unbalanced status.
U - D		Unbalance Down The displacer is being lowered and in unbalanced status.
R - U		Balance Up The displacer is being hoisted and in correction of balance.
R - D		Balance down The displacer is being lowered and in correction of balance.
LOW		The displacer is resting at the lower stop.

Note!



If no key is touched for more than 10 min., then the Proservo NMS5/7 will turn off the backlighting of the LCD to save energy, Touching a key again after this time will turn on the backlighting.

*Above Symbols available depending on the ordered specification.

6.3 Access Code

The access code is to ensure the confidentiality of the setup data. Three security levels are available, along with access codes.

Security level		Access code
0		None
1	For Operator	50
2	For Engineer	51/777

The higher levels include the lower ones. e.g. If access code 50 is specified for a function, then code 51 also enables editing. A function that requires access code 51, on the contrary, cannot be edited by code 50. However, 777 is only used to change the I.S. terminal configuration.

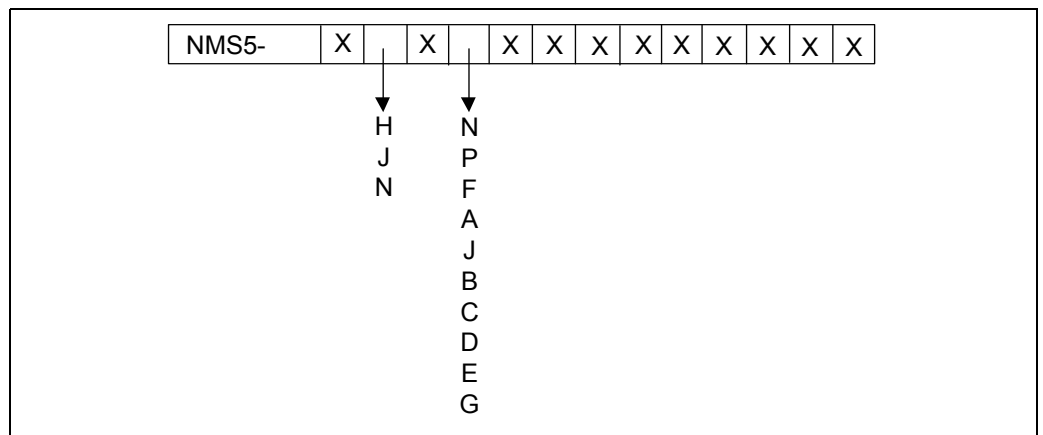

Order code which require Access Code 777

Setting an access code

Item	Procedure	Remarks
<p>Static Matrix</p>	<ol style="list-style-type: none"> At the static matrix "MORE FUNCTION", select GVH=039 "ACCESS CODE" The default value is "0". Touch the "+" key. The first digit increases to 9, then the second digit increases. Stop touching "+" once you reach "50". "50" is blinking. Gently touch "+" key again to change the first digit from 0 to 1. Now you have "51". Here touch "E"; "EDITING ENABLE" will be displayed. 	<ul style="list-style-type: none"> When you touch "E" while displaying an access code except 0, 50, or 51 "EDITING LOCKED" will appear. If an access code has not been selected before performing any settings, the screen will automatically change to show "ACCESS CODE" Operation Commands can be sent, and displayed data read, by remote systems, depending on your Proservo specification.

6.4 Operation Command and New Operation Status

6.4.1 Operation Commands

Operation Commands can be sent the Proservo from a host system. The following table explain the command codes.

Code	Command	Remarks
0	LEVEL	
1	UP	
2	STOP	After weight calibration, STOP is set as a default operation command
3	BOTTOM LEVEL	
4	UPPER INTERF. LEVEL	
5	MIDD.INTERF.LEVEL	
6	UPPER DENSITY	
7	MIDDLE DENSITY	
8	DENSITY BOTTOM	
9	REPEATABILITY	
10	WATER DIP	

6.4.2 New Operation status

The following table shows the new operation status, which is available when "NEW NMS STATUS", matrix position GVH=272, is selected to "ENABLED".

Code	Meaning	NMS Display
0	No definition	-
1	Displacer at reference position	REFERENCE
2	Displacer hoisting up	UP
3	Displacer going down	DOWN
4	Displacer stop	STOP
5	Level measurement, balanced	LEVEL
6	Upper I/F level, balanced	UPPER INTERF. LEV.
7	Middle I/F level, balanced	MIDD. INTERF. LEV.
8	Bottom meas. Balanced	BOTTOM LEVEL
9	Upper density finished	UPPER DENSITY
10	Middle density finished	MIDDLE DENSITY
11	Bottom density finished	DENSITY BOTTOM
12	Release over tension	RELE. OVER TENS.
13	Calibration activated	CAL. ACTIVE
14	Seeking level	LEVEL SEEKING
15	Following level	LEVEL FOLLOWING
16	Seeking upper density	UPP.DEN.SEEKING
17	Seeking middle density	MID.DEN.SEEKING
18	Seeking bottom density	BOT. DEN. SEEKING
19	Seeking upper I/F level	UPP. INT. SEEKING
20	Following upper I/F level	UPP. INT. FOLLOWING

Code	Meaning	NMS Display
21	Seeking middle I/F level	MID.INT.SEEKING
22	Following middle I/F level	MID.INT.FOLLOWING
23	Seeking bottom level	BOTTOM SEEKING
24	Not initialized	NO INITIALIZE
25	Stopped at upper pos.	UPPER STOP
26	Stopped at lower pos.	LOWER STOP
27	Repeatability testing	REPEATABILITY
28	Seeking water level	WATER SEEKING
29	Water level, balanced	WATER LEVEL
30	Following water level	WATER FOLLOWING
31	Over-/under tension, Z-phase, ADC error	EMERGENCY ERROR

6.5 Operation of the Displacer

The operation of the displacer for level, bottom level, interface level, and density measurement is possible by touch control.

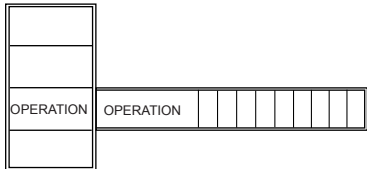
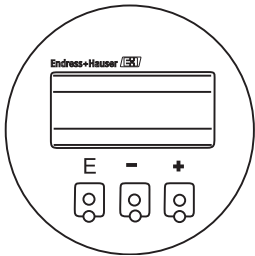
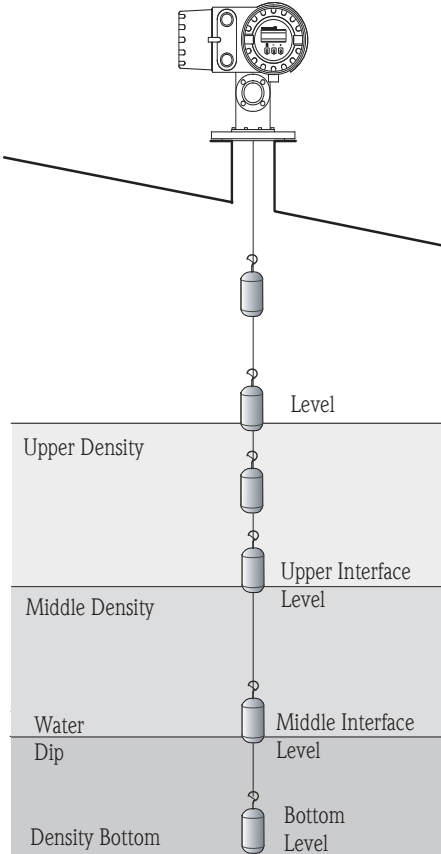
Item	Procedure	Remarks
<p style="text-align: center;">Static Matrix</p>  <p style="text-align: center;">Touch Control</p> 	<p>1) Select function group GVH=020 OPERATION</p> <p>2) Select item OPERATION. The LCD shows the command given to the Proservo NMS5/7 and the displacer position.</p>	<ul style="list-style-type: none"> ■ Set access code to 50. ■ If editing has previously been enabled by a valid access code, then the request for the code will not appear.
	<p>The following commands are available at this position:</p> <p>LEVEL UP STOP BOTTOM LEVEL UPPER INTERF. LEV* MIDD.INTERF.LEV* UPPER DENSITY* MIDDLE DENSITY* DENSITY BOTTOM* WATER DIP* REPEATABILITY TEST</p> <p>* Interface and density measurements are not available unless specifically requested. * Density profile measurement is explained in Sec 7.</p>	<ul style="list-style-type: none"> ■ The optional operation commands are available when such options are set.

6.6 Calculation of Level and Densities

The section specifies the formulae used by the Proservo NMS5/7 to calculate levels and densities.

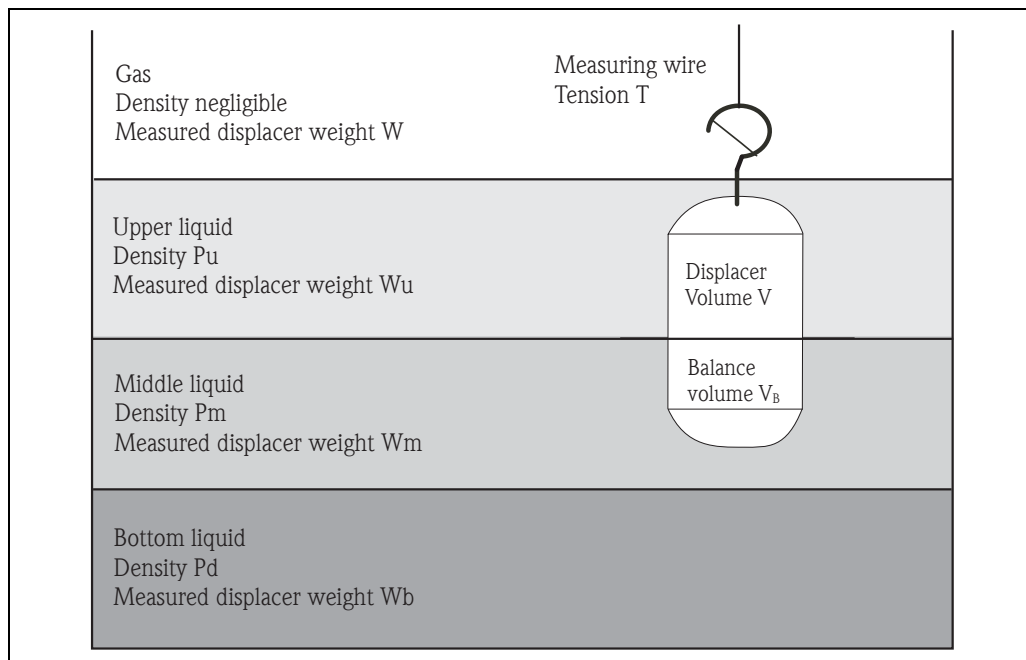

Calculation of Levels and Densities

Surface and Interface Levels

While the measured surface or interface level is constant, the displacer rests at the balancing position. The tension on the measuring wire is proportional to the displacer weight diminished by the buoyancy forces in both layers:

Level	Formula
Surface	$T = W - V_B P_u$
Upper interface	$T = W - V_B P_m - (V - V_B) P_u$
Middle interface	$T = W - V_B P_b - (V - V_B) P_m$

A rise or fall of the level will increase or decrease the submerged volume. If this change exceeds the volume tolerance set at matrix position GVH=345 "VOLUME TOLERANCE", then the corresponding change will actuate the motor of the Proservo till the balancing condition is fulfilled again.

Tank Bottom Level

For bottom level measurement, the balancing condition is defined as

$$T = W - (V + V_B) P_b$$

Densities

The upper, middle, and bottom densities are calculated by the following formulae.

- Upper density (Pu) and Density profile

$$P_u = \frac{W - W_u}{V}$$

- Middle density (Pm)

$$P_m = \frac{W_u - W_m}{V} + P_u$$

- Bottom density (Pb)

$$P_b = \frac{W_m - W_b}{V} + P_m$$

Draft

The draft depends on the shape of the displacer. For cylindrical shape, the draft is

$$D = (V_2 - V_1) / A \times 10 + h$$

where the variables and constants have the following meanings;

$$D = (VB - VD) / A \times 10 + h$$

- VB Balance volume (69cm³)
- VD Volume of the lower cone & the end of cone
- A Cross-section of the displacer
- h Height of the lower cone & the end of cone

For example: standard displacer Ø50.8 mm Cylindrical shape

- VB Balance volume (69 cm³)
- VD Volume of the lower cone (24.58 cm³)
- A Cross-section of the displacer (20.26 cm²)
- h Height of the end of cone (23 mm)

$$D = (69 - 24.58) / 20.26 \times 10 + 23$$

$$= 44.92$$

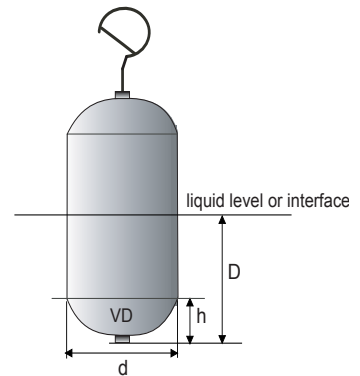

The surface or interface level should be within the cylindrical part of the displacer and approximately in the middle of its total height.

7 Commissioning

7.1 Initial settings

This section explains initial settings required at commissioning. Some, or all, of these settings may be required, depending on your Proservo specification. Set Access code 51 at GVH039 before making these initial settings.

7.1.1 System Calendar/Clock (GVH193 to 197)

Calendar/Clock values are set at factory (Japan Standard Time) prior to delivery. Change the data to reflect local time.

7.1.2 Density Values (GVH005 to 007)



Caution!

Always set GVH=005 Upper Density for actual density data, in LPG and any application where the actual density is less than 0.7000 g/ml. Failure to set this data may result in level gauge malfunction.

Density values for 3 liquid phases are set to 1.000 g/ml prior to delivery. Change the data to reflect actual density values. For tanks with only one liquid phase, set Upper Density. For tanks with 2 or 3 clear phases, set Middle and Bottom densities too. Note: minimum difference between phase settings should be at least 0.100 g/ml. *GVH005≤GVH006≤GVH007

example:

- GVH005 Upper Density: 0.758
- GVH006 Middle Density: 0.880
- GVH007 Density Bottom: 1.000

7.1.3 Tank Height (GVH140)

Tank height value is set to default value at factory prior to delivery. Tank height is the reference height, usually a gauging hatch on the tank that is used during manual level measurements. Change GVH140 to equal the reference height. Note: GVH141 "Dip Point Offset" will automatically change to reflect the difference in height between the reference height and the Proservo reference position.

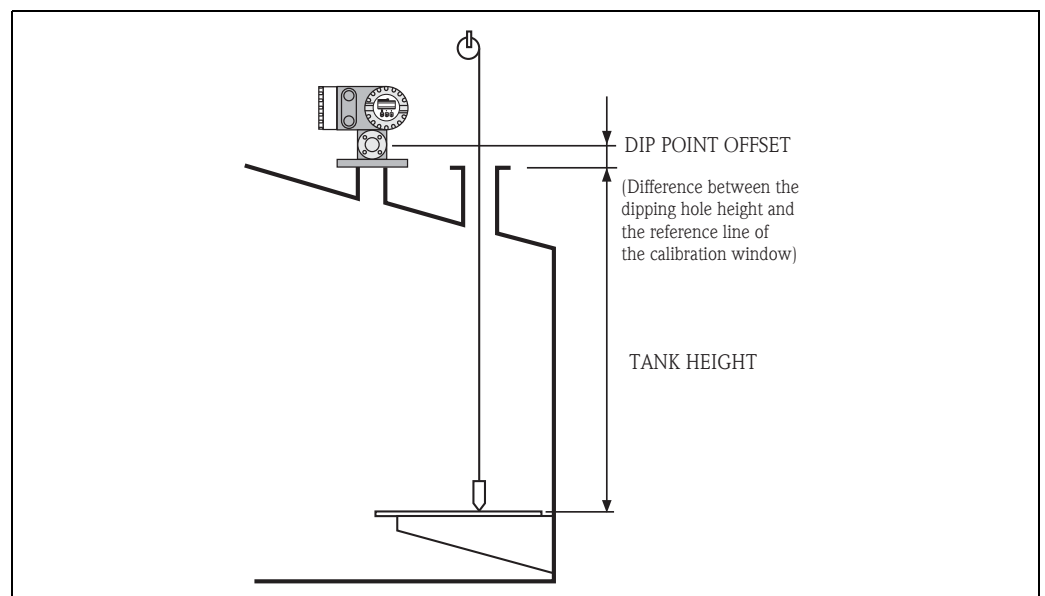

Tank Height

7.1.4 Upper/Lower Stop (GVH161/162)

Upper and Lower Stop determine the highest and lowest point of displacer movement. These data are set to 16000mm and 0mm respectively at factory prior to delivery. Change these data to the desired actual Upper and Lower limit values.

7.1.5 Communications Address (GVH285)

Several types of digital output communication protocols are available when ordered from Endress + Hauser. Your Proservo is delivered with communications hardware and/or software installed. Only minimal matrix parameter setting, Access code 51, is required.

Communications protocol is displayed and selected at G2V8H6 Protocol. Your Proservo has been preset at factory, it is not necessary to change the setting.

At GVH285 select the desired device address for Proservo. Address range: 0-9, 00-FF, or 1-247 for Modbus. Note: FF is fixed for MIC protocol. WM550 and M/S address setting is done via dip switches on the communications module inside Proservo. For Rackbus, termination resistors should be set on Proservo at end of loop. Enraf BPM address range is 00-99. Refer to Sect. 7.6 for Address Setting details.

7.1.6 Proactive Safety Function (GVH157/158/159)

Matrix	Setting
G1V5H7	Service Mode: default = OFF. Select OFF if GVH158 Prosafety = ON. Select ON only when performing maintenance on the Proservo. Warning! Selecting ON disables the Proactive Safety function! Access code 530
G1V5H8	Prosafety: default = ON. Select OFF only if the Proactive Safety function will not be used. Warning! Failure to confirm ON disables the Proactive Safety function! Access code 530
G1V5H9	Safety Level: default = 65000.0mm (WM550.), or = 99999.0 mm (other protocols) Possible data values depend on receiver specification (see table below) Access code 530

Safety level default, by output protocol

Protocol	Data range	Data format
Modbus	0.0...99999.0mm	Float
V1	0...99999.9mm	ASCII / 6 digit
MDP	0...99999mm	BCD / 5digit
WM550	0...65000mm	16bit
Mark/Space	19.999m/32.699m	20bit BCD / 5 digit
Enraf BPM	0...99999.9mm	6 or 7 byte
Rackbus	0...99999.9mm	Float
HART	0...99999.9mm	Float

7.1.7 Analogue Output (GVH250 to 256)

When specified and ordered from Endress + Hauser, Proservo is equipped with analogue output hardware installed. Function settings may be changed as follows:

Function	Setting
Assign Output 1	Assign level or temperature to channel 1 output.
Adjust 4mA	set desired value at which level or temperature outputs 4 mA.
Adjust 20mA	set desired value at which level or temperature outputs 20 mA
Assign Output 2	Assign level or temperature to channel 2 output.
Adjust 4mA	set desired value at which level or temperature outputs 4 mA
Adjust 20mA	set desired value at which level or temperature outputs 20 mA.
Device at Alarm	select type of output for alarm

7.1.8 Contact Relay Alarm Output (GVH240 to 247)

When specified and ordered from Endress + Hauser, Proservo is equipped with contact relay alarm output hardware installed. Function settings may be changed as follows:

Function	Setting
Select Relay	select from Relay 1, 2, 3 or 4
Assign Relay	Select output definition from range of choices: None, Level, Liquid Temperature, Caution, Warning, Emergency Error, Balance Signal
Relay Function	select High or Low
Switching Point:	set value at which relay is activated
Hysteresis	set hysteresis value for selected relay
Relay on Alarm	select from Normal Open or Normal Closed
On Delay Time	set time delay value for alarm output start
Off Delay Time	set delay value for alarm output stop

7.2 Settings for Prothermo NMT 53x Connections

The following settings are required to display Prothermo NMT 539 data on Proservo screens.

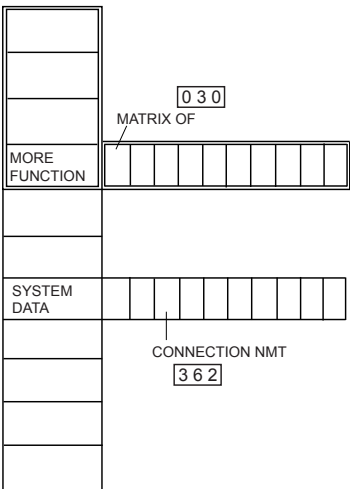
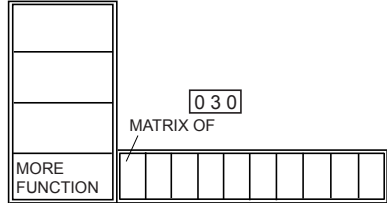
Item	Procedure	Remarks
<p style="text-align: center;">Matrix Group: SERVICE</p>  <p style="text-align: center;">Static Matrix</p> 	<ol style="list-style-type: none"> 1) In Static Matrix "MORE FUNCTION", invoke GVH=030 "MATRIX OF" and select "SERVICE". 2) Invoke the Dynamic Matrix GVH=362 "CONNECTION NMT" screen. 3) Use the "+" and "-" keys to display "AVERAGE" and press "E" to set data. 4) Press "E" to return to "SYSTEM DATA" and press the "-" key to return to "MORE FUNCTION". 5) Invoke Static Matrix "GVH=030 MATRIX OF". The Proservo matrix is divided into matrix groups. Select "TEMPERATURE" from these groups. 6) "EDITING ENABLED" is displayed on the LCD. 7) The average liquid temperature is displayed on Dynamic Matrix screen GVH=440. 8) The temperature of each contact is displayed on Dynamic Matrix screens GVH=450 to GVH=459. 	<ul style="list-style-type: none"> ■ Set access code 51. ■ NMS HART connection (terminal 24 & 25) must have corresponding IS input in order to configure NMT IS version. ■ The Static Matrix GVH=010 "LIQUID TEMP." screen also displays the average temperature.

 **Caution!** For Prothrmio NMT535/539/532 connections, refer to the appropriate operating manual for your device.

7.3 Settings for Promonitor NRF 560 Connections

To connect a Promonitor NRF 560, the Proservo requires the following settings.

 **Caution!**
Turn on the power to Proservo NMS5/7 first.

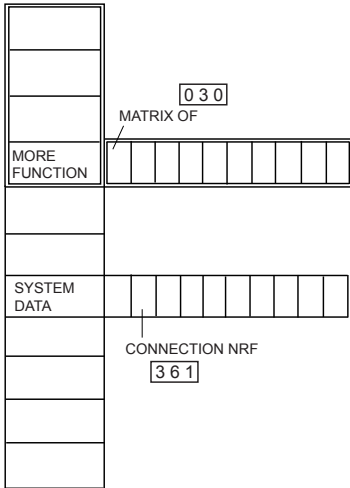
Item	Procedure	Remarks
<p style="text-align: center;">Matrix Group: SERVICE</p> 	<ol style="list-style-type: none"> 1) In Static Matrix "MORE FUNCTION", invoke GVH=030 "MATRIX OF" and select "SERVICE". 2) Invoke the Dynamic Matrix GVH=361 "CONNECTION NRF" screen. 3) Use the "+" and "-" keys to select either "CONTACT 1" or "CONTACT 2". 4) The setting is complete. 	<ul style="list-style-type: none"> ■ Set access code 51. ■ CONTACT 1... Prothermo NRF 560 software version 1.6x and earlier (those Promonitor NRF 560 that indicate no software version correspond to connection type 1). ■ CONTACT 2... Prothermo NRF 560 software version 1.8x and later.

7.4 Liquid Level Calibration

7.4.1 Opened tank

7.4.1.1 Preparation

Select LEVEL at GVH020 Operation. The displacer will descend to the liquid surface and balance. When "BAL" is displayed, the displacer has stopped moving.

Manually measure the liquid level using an approved method.

7.4.1.2 Set Level (GVH150) for opening tank

At GVH150 input the liquid level obtained from manual measurement (above).

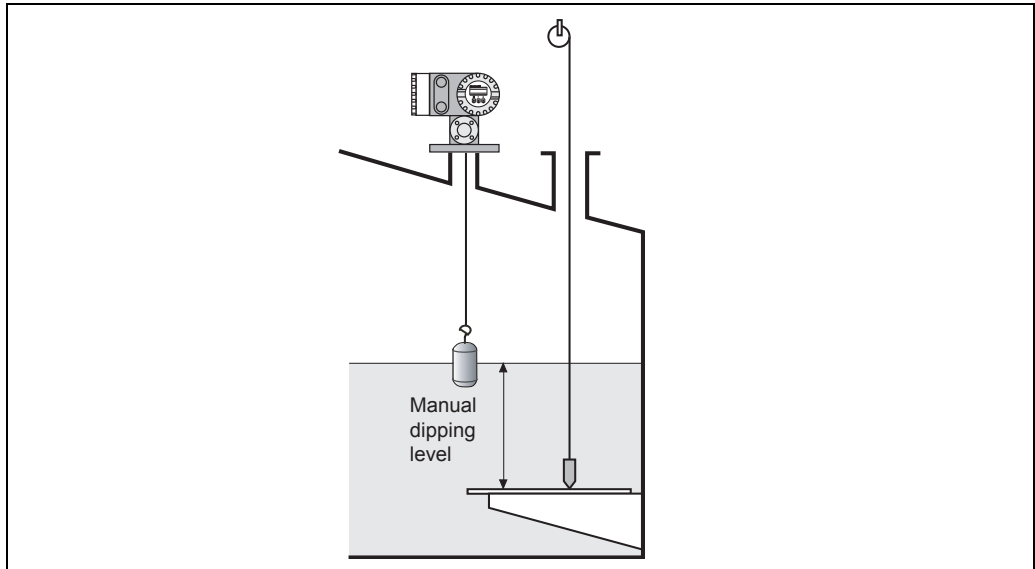

Calibration Level (manual dipping level)

When there is not liquid in the tank:

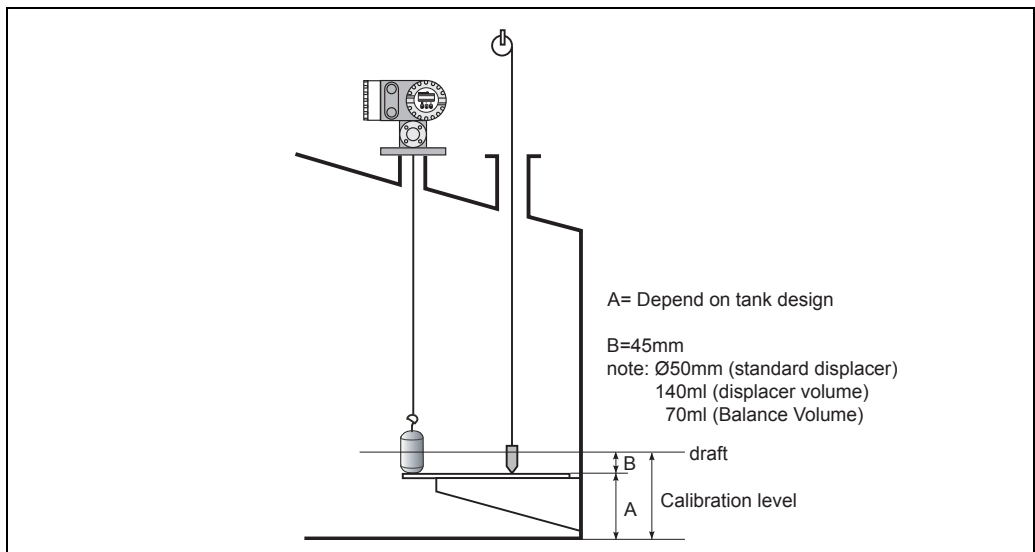

Calibration Level (empty tank)

Note!

When there is not liquid in the tank, level calibration is not 0mm on measurement principle. In case of need 0mm level calibration, please refer to GVH004(BOTTOM LEVEL) or GVH142(DIS-PLAC. DRAFT).

7.4.2 Closed tank

7.4.3.1 Level calibration for closed tank

LPG tank can not measure the manual dipping because the tank can not open. Please implement it according to the following procedure.

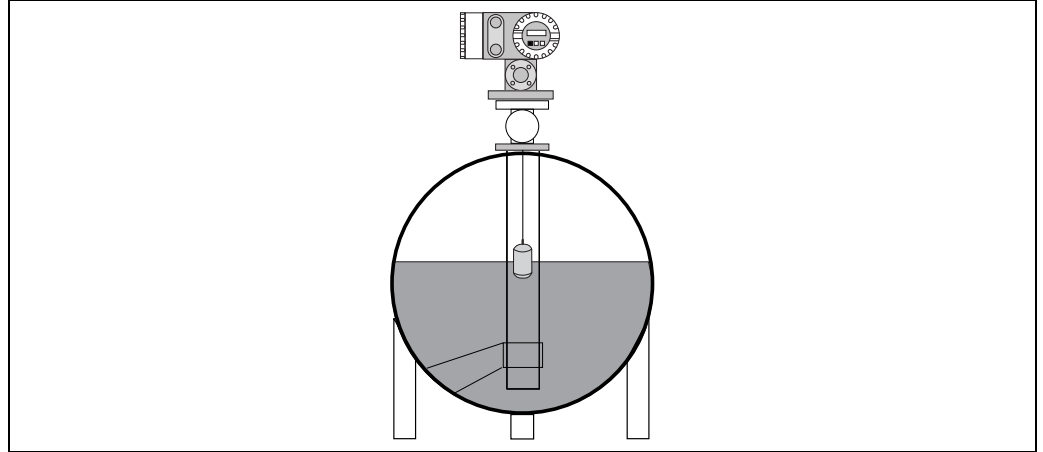

1. Check the NMS parameter

GVH	ITEM
005	UPPER DENSITY
340	WIRE DRUM CIRC.
342	DISPLACER WEIGHT
343	DISPLACER VOLUM
344	BALANCE VOLUM

2. Set the Level gauge to GVH020(BOTTOM)

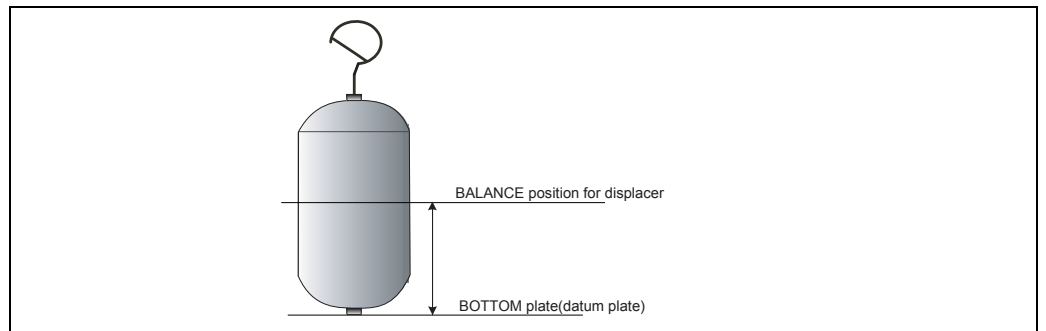

3. Check the Balance

Check that the displacer is balanced.

4. Calculate the displacer balance position.

In case of Ø50 standard displacer, when balance volume(GVH343) is reference value (a half of displace volume), the balance point is 45mm from bottom.

Note!

 Please contact us about the other size displacer.

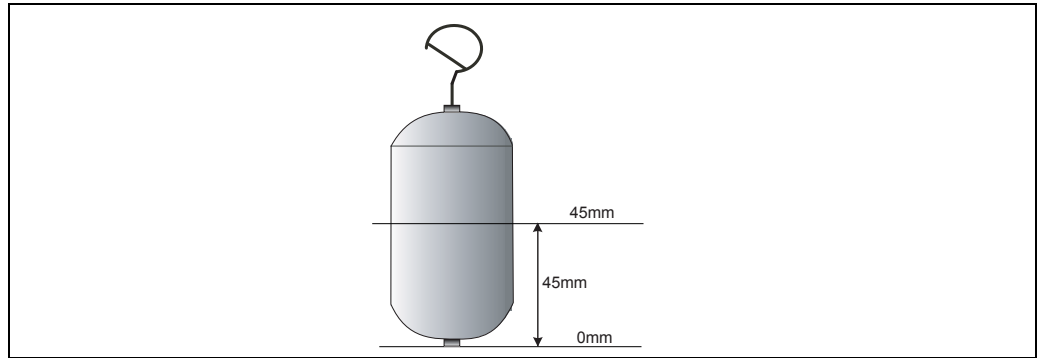

5. Level Calibration

Set Level Calibration to 45mm at GVH150 (SET LEVEL) in G1 MATRIX (Calibration).

The bottom is ZERO. If the bottom plate is not Zero (ex; X mm), please adjust the level value by adding to the value.

$$\text{LEVEL} = X + 45(\text{mm})$$

7.5 Remote Communications

7.5.1 Digital Output

At G2V8H5 Address, set the desired loop address for most digital protocols. Depending on the protocol installed in your Proservo, the range of possible addresses differs. Range is 0-9, 00-FF (FF is fixed for MIC protocol), or 1-247 for Modbus.

- WM550 and Mark Space protocols addresses must be set by switches on the communications module inside the Proservo.
- MODBUS: Termination resistors should be set on BODBUS modules (see Appendix 13.1 RS-485 MODBUS (COMM-5) Terminator).
- Enraf BPM: Address range is 00-99. A-F is not available.

7.5.2 Whessoe Matic 550 (WM550) Communication Board Setting

7.5.2.1 Jumper setting

Jumper settings for WM550 communication board.

Jumper	Function	Default condition
J3 (Mode)	Use EPROM [IC4]->short	Short
J4 (Test)	Software testing	Short
J6 (Reset)	Reset	Open
J7 (Watch dog)	Watch dog setting	Short

To loaded software into processor [IC1] J3 has to be open.

If software testing is required; J4 has to be open.

If software reset is required; J6 has to be short.

7.5.2.2 Polling address setting

Caution!



Polling addresses are set by mechanically at SW1 on WM550 communication board (not by accessing NMS programming matrix). Check all polling addresses before setting.

The following table shows about address setting.

Switch Position	Value
1	1
2	2
3	4
4	8
5	16
6	32

Polling address = 1

Polling address = 5

Polling address = 9

Polling address = 3

Polling address = 7

Setting Example

Note!



For current loop setting, please refer a operating manual for Whessoe 1098 or RTU 8130 operating manual.

7.5.3 Mark/Space(M/S) Communication Board setting

7.5.3.1 Jumper setting

Jumper settings for M/S communication board.

Jumper	Function	Default condition
J3 (Mode)	Use EPROM [IC4]->short	Short
J3 (Reset)	Reset	Open
J3 (WD)	Watch dog setting	Short

7.5.3.2 Polling address setting

Caution!



Polling addresses are set by mechanically at SW1 (1-8) and SW2(1-2) on Mark Space communication board (not by accessing NMS programming matrix). Check all polling addresses before setting. The following table shows address setting.

Switch Position	Value
SW1-1	1
SW1-2	2
SW1-3	4
SW1-4	8
SW1-5	16
SW1-6	32
SW1-7	64
SW1-8	128
SW2-1	256
SW2-2	512

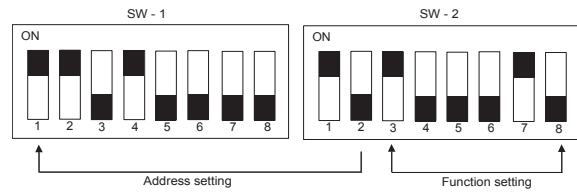

Setting Example (above example:267)

Function setting

Each function is set with SW-2 as following table.

Switch	Function	Default condition
SW2-3	ON: Data transmission under unbalanced condition	ON
SW2-4	ON: low baud rate setting	OFF
SW2-5	ON: Feet data OR 0-20m, OFF: 0-30m	OFF
SW2-6	ON: Measured data converted to feet	OFF
SW2-7	ON: Temperature data (57 bits)	ON
SW2-8	ON: Deg. F measured temperature unit, OFF: Deg. C	OFF

7.5.4 ENRAF Bi Phase Communication Board (COM-3) Setting

7.5.4.1 Jumper setting

COM-3 Communication board jumper setting.

Jumper	Function	Default condition
JP1 (Mode)	ROM type setting 1-2 short: 27C4096 2-3 short: 27C1024	2-3 short
JP2 (Reset)	CPU mode setting	1-2 open 3-4 short 5-6 short
J3 (WD)	Baud rate setting 1-2 short: 1200 bps 1-2 open: 2400 bps	1-2 Short

7.5.4.2 Communication setting

At the matrix position GVH=286, select "V1/ENRAF BPM".

7.5.4.3 Communication setting

Polling address setting is possible by accessing to the Proservo matrix, GVH=285 "ADDRESS". As polling address, 00-99 is possible to use.

Caution!



As polling address, A-F is not possible to use.

7.5.4.4 Communication setting

- Switch S1: Reset switch
- Connector J3: Communication port for debugging
-

7.5.5 Analog Output

Analog output 4-20 mA is available when ordered from Endress + Hauser. Your Proservo is delivered with analog output hardware installed. For the following matrix parameter settings, Access code 51, is required.

Matrix	Item	Setting
G2V5H0	Assign Output	Assign analog output (Level or Temperature) for channel 1.
G2V5H1	Adjust 4 mA	Set level or temperature value for 4 mA output on channel 1. Available only when G2V5H0= "Level" or "Liquid Temp"
G2V5H2	Adjust 20 mA	Set level or temperature value for 20mA output on channel 1. Available only when G2V5H0 = "Level" or "Liquid Temp."
G2V5H3	Assign Output 2	Assign analog output (Level or Temperature) for channel 2.
G2V5H4	Adjust 4mA	Set level or temperature value for 4mA output on channel 2. Available only when G2V5H3 = "Level" or "Liquid Temp."
G2V5H5	Adjust 20mA:	Set level or temperature value for 20mA output on channel 2. Available only when G2V5H3 = "Level" or "Liquid Temp."
G2V5H6	Device at Alarm	Select type of output for alarm. Select from OFF, HOLD current output, Maximum value or Minimum value.

7.5.6 Contact Relay Alarm Output

Contact relay alarm output is available when ordered from Endress + Hauser. Your Proservo is delivered with analog output hardware installed. Maximum 4 contact relay alarm settings are available. The following matrix parameter settings, Access code 51, are required.

Matrix	Item	Setting
G2V4H0	Select Relay	Use +/- and E keys to select to activate Contact Output Relays 1 to 4. Default value = 1.
G2V4H1	Assign Relay	Select output definition from range of choices: None, Level, Liquid Temp, Caution, Warning, Emergency Error, and Balance Signal. Default value = NONE.
G2V4H2	Relay Function	Select High or Low function, available only when G2V4H1 = "Level" or "Liquid Temp." Default value = HIGH.
G2V4H3	Switching Point	Set level (0-99999 mm) at which relay is activated, available only when G2V4H1 = "Level" or "Liquid Temp." Default value = 0 mm.
G2V4H4	Hysteresis	Set hysteresis value (0-99999 mm) for selected relay, available only when G2V4H1 = "Level" or "Liquid Temp." Default value = 0 mm.
G2V4H5	Relay on Alarm	Select from Normal Open or Normal Closed, available only when G2V4H1 = "Level" or "Liquid Temp." Default value = NORMAL OPENED.
G2V4H6	On Delay time	Set delay time (0-999 seconds) for alarm output start, available only when G2V4H1 = "Level" or "Liquid Temp." Default value = 0 seconds.
G2V4H7	Off Delay Time	Set delay time (0-999 seconds) for alarm stop, available only when G2V4H1 = "Level" or "Liquid Temp." Default value = 0 seconds.

Error type	Contents
LEVEL	Upper or Lower limit exceeded
LIQUID TEMPERATURE	Upper or Lower limit exceeded
CAUTION	Auto wire calibration error; Auto displacer calibration error
WARNING	Upper weight limit exceeded (GVH162); Lower weight limit exceeded (GVH163); Local communication error; NMT error; LCD error; communication error; EEROM data error
EMERGENCY ERROR	Z-phase no input error; ADC sensor error; communication IC error; A-phase no input error

7.6 Density Measurement and Density Profile Measurement

Two different types of density measurement are available when ordered from Endress + Hauser.

- Spot density measurement for up to 3 liquid phases
- Density profile measurement
 - A. Tank profile for up to 16 points for total liquid height.
 - B. Tank profile for upper phase liquid only.
 - C. Tank profile based on a manually entered profile parameter.

7.6.1 Spot Density Measurement

Spot measurement for up to 3 liquid phases is an option that is available when ordered from Endress + Hauser.

The following preconditions are required in order to assure safe and accurate operation.

- Proservo must be configured for Spot density measurement as ordered from Endress+Hauser. For information regarding upgrading your Proservo, please contact Endress+Hauser.
- Density values:

- Upper Density < Middle Density < Bottom Density
- Middle Density - Upper Density ≥ 0.100 g/cm³
- Bottom Density - Middle Density ≥ 0.100 g/cm³

e.g. 0.760 g/cm ³
e.g. 0.880 g/cm ³
e.g. 0.1000 g/cm ³

(Example)

-Density values can be viewed and changed at the following matrix positions:

- GOV0H5 Upper Density
- GOV0H6 Middle Density
- GOV0H7 Density Bottom

- The displacer is balanced at liquid level and the liquid surface is not moving.

For spot density measurement, you may set or select the following parameters. Alternatively, you may accept the factory default settings:

Matrix	Item	Setting
G1V4H3	Displacer Raise Dens	Set distance (0-300mm) for displacer to rise above level position during Density operations. Default setting = 150 mm. Observe the rule: G1V4H3 + G1V4H4 = 300 n, where n = integer.
G1V4H4	Displacer Subm. Dens	Set distance (0-300mm) for displacer to sink below level position during Density operations. Default setting = 150 mm. Observe the rule: G1V4H3 + G1V4H4 = 300 n, where n = integer.

Operation

At GOV2H0 "OPERATION", select the desired density operation: UPPER DENSITY, MIDDLE DENSITY, or DENSITY BOTTOM. Proservo raises the displacer up out of the liquid, measures its weight, and sends the displacer down to measure density. After density is measured the displacer remains at that position until UP or LEVEL command are selected at GOV2H0 "Operation."

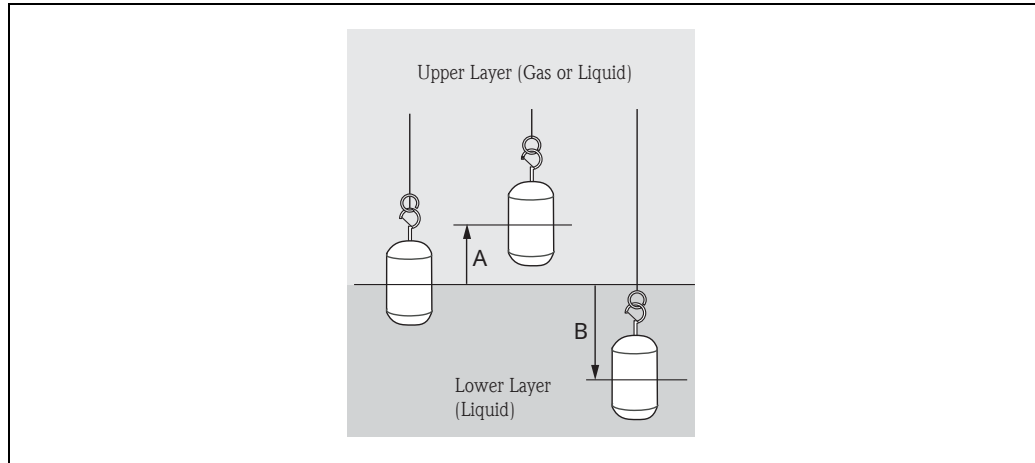

Density profile measurement

7.6.2 Density Profile Measurement

Tank Profile Density Measurement

In addition to the preconditions, the following additional preconditions are required in order to assure safe and accurate operation for tank profile density measurement.

Access Code 51 is required to edit parameters.

- Proservo must be configured for Spot & Profile density measurement as ordered from Endress+Hauser. For information regarding upgrading your Proservo, please contact Endress+Hauser.
- Tank Bottom Level GVH004 must = 0 If not, (e.g. actual bottom = 884mm) Proservo will try to calculate profile intervals based on Measured Level divided by OPE. Point (GVH000 / GVH841). But the displacer will hit bottom before being able to measure points below e.g. 884mm.
- If Bottom Level is not 0 mm, select Manual I/F Profile at GVH840. Set GVH843 I/F Manual Level = actual bottom level e.g. 884mm. In this case the intervals will be calculated based on (GVH000 - GVH843)/GVH841.
- There must be no movement or transfer of product, into or out of the tank, during density profile operation. Note that, depending on the height of liquid in the tank, density profile operation may take 1 hour or more.

Matrix	Item	Setting
G1V5H4	Safe Density	Select the desired resultant condition when density profile measurement fails due to displacer reaching the low-limit for density profile operation (set in G1V5H5). Selecting "ON" will result in STOP operation. Selecting "IGNOR" will result in "LEVEL" operation, displacer will return to liquid level. Selecting "OFF" will leave the displacer at the position where density profile measurement failed, and in "DENSITY" operation.
G1V5H5	Den Ope Level	Set the lower limit for displacer movement during density profile operation. Default setting = 300 mm.

Note!



Additional matrix parameter settings are required for remote communications via WM550 communications protocol.

Refer to Section 11. "Matrix, (Dynamic Matrix, Device Data : G2), WM550 DENS. SEL."

- A. Tank profile for up to 16 points for total liquid height
G8V4H0 Ope Select: Select 1: Tank Profile.
- B. Tank profile for upper phase liquid only
G8V4H0 Ope Select: Select 2: I/F Profile.
- C. Tank profile for based on a manually entered profile parameter.
G8V4H0 Ope Select: Select 3: MANU.I/F Profile.

For choices A, B, and C above, you may set or select the following parameters. Alternatively, you may accept the factory default settings:

Matrix	Item	Setting
G8V4H1	Ope Point	Set the number of measurement points (2-16) for Tank Profile measurement. Default setting = 2.
G8V4H3	I/F Manu. Level	Manually set the water interface level (0-99999.9mm) to be referenced during Tank Profile measurement. Default setting = 0 mm. <u>Only used with C, tank profile for based on a manually entered profile parameter.</u>
G8V4H4	Bal. Level	Set the allowance for level movement (1.0 -99.9 mm) prior to Tank Profile operation. If level movement exceeds this value, Profile operation is canceled. Setting 99.9mm allows Profile measurement to proceed, regardless of level movement. Default setting = 2.0 mm.
G8V4H5	Up Wait Time	Set waiting time (1-31 minutes) for displacer weight to be measured in air, when making the weight table at start of Profile operation. Default setting = 1 minute.
G8V4H6	Liq Wait Time	Set the time (1-31 minutes) for displacer to stop at each measurement position during profile operation. Default setting = 1 minute.
G8V4H7	Ope Wait Time	Set maximum waiting time (1-31 minutes) for conditions in G8V4H4 (Bal Level) to be satisfied before profile operation begins. E.g. if level movement exceeds setting at G8V4H4, Proservo is in "standby" for the time set in this matrix. After the maximum time elapses, profile operation is canceled. Default setting = 1 minute.

Initial setting of Tank Profile (Density profile) measurement

All of necessary set up can be done at the "G8 Tank Profile" matrix as explained earlier. There are six factors to configured prior to the actual operation.

G8V4H0 OPE. SELECT

Item	Procedure	Remarks
<p>The screenshot shows the 'G8V4H0 OPE. SELECT' menu. At the top, it says 'Matrix Group : TANK PROFILE'. Below that, there are three main sections: 'Static Matrix' with a 'GVH=030' label and a 'MORE FUNCTION' button; 'Dynamic Matrix' with a 'GVH=040' label and a 'TANK PROFILE' button; and 'Function Group' with a 'STATUS DATA' button and a list of options: 'PROFILE OPE 1-10', 'DENSITY 11-16', 'Position 1-10', and 'Position 10-16'.</p>	<ul style="list-style-type: none"> ■ Select G0V3H0 "MATRIX OF" in the row "MORE FUNCTION" on Static Matrix, then select "Tank profile". 	Set access code to 50
	<ul style="list-style-type: none"> ■ Select function group "PROFILE OPE" and G8V4H0 "OPE SELECT". 	The row of PROFILE OPE is the only function group that needs configuration for the density profile operation.
	<ul style="list-style-type: none"> ■ Select 1: "TANK PROFILE" by pressing + or - key. ■ Then press E to configure. 	Selection of "0:SPOT" enables Upper Density measurement instead of Density Profile measurement.

G8V4H1 OPE. POINT

Item	Procedure	Remarks																																																												
<p>Matrix Group: TANK PROFILE</p> <p>Function Group</p> <table border="1" style="width: 100%; border-collapse: collapse;"> <tr> <td style="width: 10%;">PROFILE OPE.</td> <td style="width: 10%;">OPE. POINT</td> <td style="width: 10%;"></td> <td style="width: 10%;"></td> <td style="width: 10%;"></td> <td style="width: 10%;"></td> <td style="width: 10%;"></td> <td style="width: 10%;"></td> <td style="width: 10%;"></td> <td style="width: 10%;"></td> </tr> <tr><td> </td><td> </td><td> </td><td> </td><td> </td><td> </td><td> </td><td> </td><td> </td><td> </td></tr> <tr><td> </td><td> </td><td> </td><td> </td><td> </td><td> </td><td> </td><td> </td><td> </td><td> </td></tr> <tr><td> </td><td> </td><td> </td><td> </td><td> </td><td> </td><td> </td><td> </td><td> </td><td> </td></tr> <tr><td> </td><td> </td><td> </td><td> </td><td> </td><td> </td><td> </td><td> </td><td> </td><td> </td></tr> <tr><td> </td><td> </td><td> </td><td> </td><td> </td><td> </td><td> </td><td> </td><td> </td><td> </td></tr> </table>	PROFILE OPE.	OPE. POINT																																																											<ul style="list-style-type: none"> ■ Select G8V4H1 "OPE POINT" to determine number of density measuring points. ■ Enter required number by pressing + or - key, and E to confirm. 	<ul style="list-style-type: none"> ■ Set access code to 51. Default value is 2 points and selectable up to 16 points ■ Whatever the number of measuring point is selected, the measuring interval & point between each point are automatically calculated within the liquid level.
PROFILE OPE.	OPE. POINT																																																													

G8V4H4 BAL. LEVEL

Item	Procedure	Remarks																																																												
<p>Matrix Group : TANK PROFILE</p> <p>Function Group</p> <p style="text-align: right;">GVH=844</p> <table border="1" style="width: 100%; border-collapse: collapse;"> <tr> <td style="width: 10%;">TANK PROFILE</td> <td style="width: 10%;"></td> <td style="width: 10%;"></td> <td style="width: 10%;"></td> <td style="width: 10%;"></td> <td style="width: 10%;">BAL. LEVEL</td> <td style="width: 10%;"></td> <td style="width: 10%;"></td> <td style="width: 10%;"></td> <td style="width: 10%;"></td> </tr> <tr><td> </td><td> </td><td> </td><td> </td><td> </td><td> </td><td> </td><td> </td><td> </td><td> </td></tr> <tr><td> </td><td> </td><td> </td><td> </td><td> </td><td> </td><td> </td><td> </td><td> </td><td> </td></tr> <tr><td> </td><td> </td><td> </td><td> </td><td> </td><td> </td><td> </td><td> </td><td> </td><td> </td></tr> <tr><td> </td><td> </td><td> </td><td> </td><td> </td><td> </td><td> </td><td> </td><td> </td><td> </td></tr> <tr><td> </td><td> </td><td> </td><td> </td><td> </td><td> </td><td> </td><td> </td><td> </td><td> </td></tr> </table>	TANK PROFILE					BAL. LEVEL																																																							<ul style="list-style-type: none"> ■ Select G8V4H4 "BAL LEVEL" to determine the liquid stability range in order to start the operation. ■ Enter desired value by pressing + or - key and E to confirm. Input value of 99.9mm represents that activation of measuring procedure regardless of level condition. 	<ul style="list-style-type: none"> ■ Set access code to 51. NMS softwear has a function to scan & record the liquid level every 5 minutes. ■ NMS only starts the actual measurement when the liquid level is within the entered value compared to the recorded level data 5 minutes ago. This function ensures the safe operating condition to avoid filling or draining liquid from the tank.
TANK PROFILE					BAL. LEVEL																																																									

G8V4H5 UP WAIT TIME

Item	Procedure	Remarks																																																												
<p>Matrix Group : TANK PROFILE</p> <p>Function Group</p> <p style="text-align: right;">GVH=845</p> <table border="1" style="width: 100%; border-collapse: collapse;"> <tr> <td style="width: 10%;">TANK PROFILE</td> <td style="width: 10%;"></td> <td style="width: 10%;"></td> <td style="width: 10%;"></td> <td style="width: 10%;"></td> <td style="width: 10%;">UP WAIT TIME</td> <td style="width: 10%;"></td> <td style="width: 10%;"></td> <td style="width: 10%;"></td> <td style="width: 10%;"></td> </tr> <tr><td> </td><td> </td><td> </td><td> </td><td> </td><td> </td><td> </td><td> </td><td> </td><td> </td></tr> <tr><td> </td><td> </td><td> </td><td> </td><td> </td><td> </td><td> </td><td> </td><td> </td><td> </td></tr> <tr><td> </td><td> </td><td> </td><td> </td><td> </td><td> </td><td> </td><td> </td><td> </td><td> </td></tr> <tr><td> </td><td> </td><td> </td><td> </td><td> </td><td> </td><td> </td><td> </td><td> </td><td> </td></tr> <tr><td> </td><td> </td><td> </td><td> </td><td> </td><td> </td><td> </td><td> </td><td> </td><td> </td></tr> </table>	TANK PROFILE					UP WAIT TIME																																																							<ul style="list-style-type: none"> ■ Select G8V4H4 "UP WAIT TIME" to determine the displacer weight calibration interval in air. ■ Enter desired waiting time by pressing + or - key, and E to confirm. 	<ul style="list-style-type: none"> ■ Set access code to 51. The displacer raises approximately 500mm above liquid surface after confirming the stability of liquid level within "BAL LEVEL" function ■ The displacer weight is calibrated at 8 different positions in air and the interval between those positions is adjustable within this function to allow excess liquid to drip off the displacer to achieve higher accuracy.
TANK PROFILE					UP WAIT TIME																																																									

G8V4H6 LIQ. WAIT TIME

Item	Procedure	Remarks																																																		
<p>Matrix Group : TANK PROFILE</p> <p>Function Group</p> <p style="text-align: right;">GVH=846</p> <table border="1" style="width: 100%; border-collapse: collapse;"> <tr> <td style="width: 10%;">TANK PROFILE</td> <td style="width: 10%;"></td> <td style="width: 10%;"></td> <td style="width: 10%;"></td> <td style="width: 10%;"></td> <td style="width: 10%;"></td> <td style="width: 10%;"></td> <td style="width: 10%;"></td> <td style="width: 10%;">LIQ. WAIT TIME</td> <td style="width: 10%;"></td> </tr> <tr><td></td><td></td><td></td><td></td><td></td><td></td><td></td><td></td><td></td><td></td></tr> <tr><td></td><td></td><td></td><td></td><td></td><td></td><td></td><td></td><td></td><td></td></tr> <tr><td></td><td></td><td></td><td></td><td></td><td></td><td></td><td></td><td></td><td></td></tr> <tr><td></td><td></td><td></td><td></td><td></td><td></td><td></td><td></td><td></td><td></td></tr> </table>	TANK PROFILE								LIQ. WAIT TIME																																										<ul style="list-style-type: none"> ■ Select G8V4H6 "LIQ. WAIT TIME" to determine the displacer weight calibration interval between each measuring point in the liquid. ■ Enter desired waiting time by pressing + or - key, and E to confirm. 	<ul style="list-style-type: none"> ■ Set access code to 51. A small turburanc made by the movement of displacer itself may cause the liquid surrounding displacer to be unstable for the precise measurement. ■ This function allows displacer to hold in each calculated position before actual measurement is proceeded based on the entered value.
TANK PROFILE								LIQ. WAIT TIME																																												

G8V4H7 OPE. WAIT TIME

Item	Procedure	Remarks																																																		
<p>Matrix Group : TANK PROFILE</p> <p>Function Group</p> <p style="text-align: right;">GVH=847</p> <table border="1" style="width: 100%; border-collapse: collapse;"> <tr> <td style="width: 10%;">TANK PROFILE</td> <td style="width: 10%;"></td> <td style="width: 10%;"></td> <td style="width: 10%;"></td> <td style="width: 10%;"></td> <td style="width: 10%;"></td> <td style="width: 10%;"></td> <td style="width: 10%;"></td> <td style="width: 10%;">OPE. WAIT TIME</td> <td style="width: 10%;"></td> </tr> <tr><td></td><td></td><td></td><td></td><td></td><td></td><td></td><td></td><td></td><td></td></tr> <tr><td></td><td></td><td></td><td></td><td></td><td></td><td></td><td></td><td></td><td></td></tr> <tr><td></td><td></td><td></td><td></td><td></td><td></td><td></td><td></td><td></td><td></td></tr> <tr><td></td><td></td><td></td><td></td><td></td><td></td><td></td><td></td><td></td><td></td></tr> </table>	TANK PROFILE								OPE. WAIT TIME																																										<ul style="list-style-type: none"> ■ Select G8V4H7 "OPE. WAIT TIME" to determine the operation holding time limit to accept "BAL. LEVEL" before the actual operation starts. ■ Enter desired waiting time by pressing + or - key, and E to confirm. 	<ul style="list-style-type: none"> ■ Set access code to 51. Entire operation begins only when the condition described in "BAL. LEVEL" is achieved. ■ This function determines how long for the NMS to wait if "BAL. LEVEL" can not be established before quitting entire operation.
TANK PROFILE								OPE. WAIT TIME																																												

Operation of Tank Profile (Density Profile) measurement

After all of initial settings are completed, the actual operation can be proceeded by one simple command. The operation status regarding this function is displayed on G8V5H0 and the liquid level condition is also displayed on G8V5H1. Terms of status display and descriptions are listed below.

Operations status (G8V5H0, OPE. STATUS)

Status	Contens
0: Accepting	Accepting density profile command
1: Standby	Ready to execute density profile command
2: In operation	Executing density profile command
3: OPR. END	Density profile operation completed successfully
4: UN_BALANCE ERR	Fail: Required conditions for density profile operation not satisfied
5: IPR. ERR. STOP	Fail: Abnormal conditions occurred during density profile operation

Level condition status (G8V5H1, LEVEL CONDITION)

Status	Contents
0: Off Level Meas.	Active operation is not LEVEL (Profile cannot start)
1: Stable	Liquid level/surface is stable (Profile can start)
2: Unstable	Liquid level/surface is unstable (Profile cannot start)
3: Ignor condition	Ignores liquid level/surface condition (profile cannot start)

Item	Procedure	Remarks
<p>Static Matrix</p>	<ul style="list-style-type: none"> ■ Select G0V2H0 "OPERATION" in the Static Matrix, then select "UPPER DENSITY". 	<ul style="list-style-type: none"> ■ Set access code to 50. ■ The operation command "UPPER DENSITY" is shared between spot and Tank Profile density measurement depends on G8V4H0 configuration.
	<ul style="list-style-type: none"> ■ Press E to start the operation. 	<ul style="list-style-type: none"> ■ The operation must start when the NMS is in Level measuring mode.
	<ul style="list-style-type: none"> ■ Unless there is any incompatible circumstances during the displacer automatically returns to the level measurement after the last measuring point. 	<ul style="list-style-type: none"> ■ To minimize the risk of safe operation, the displacer immediately returns to the Level measurement regardless of completing various data process.

Density profile Operation Diagram

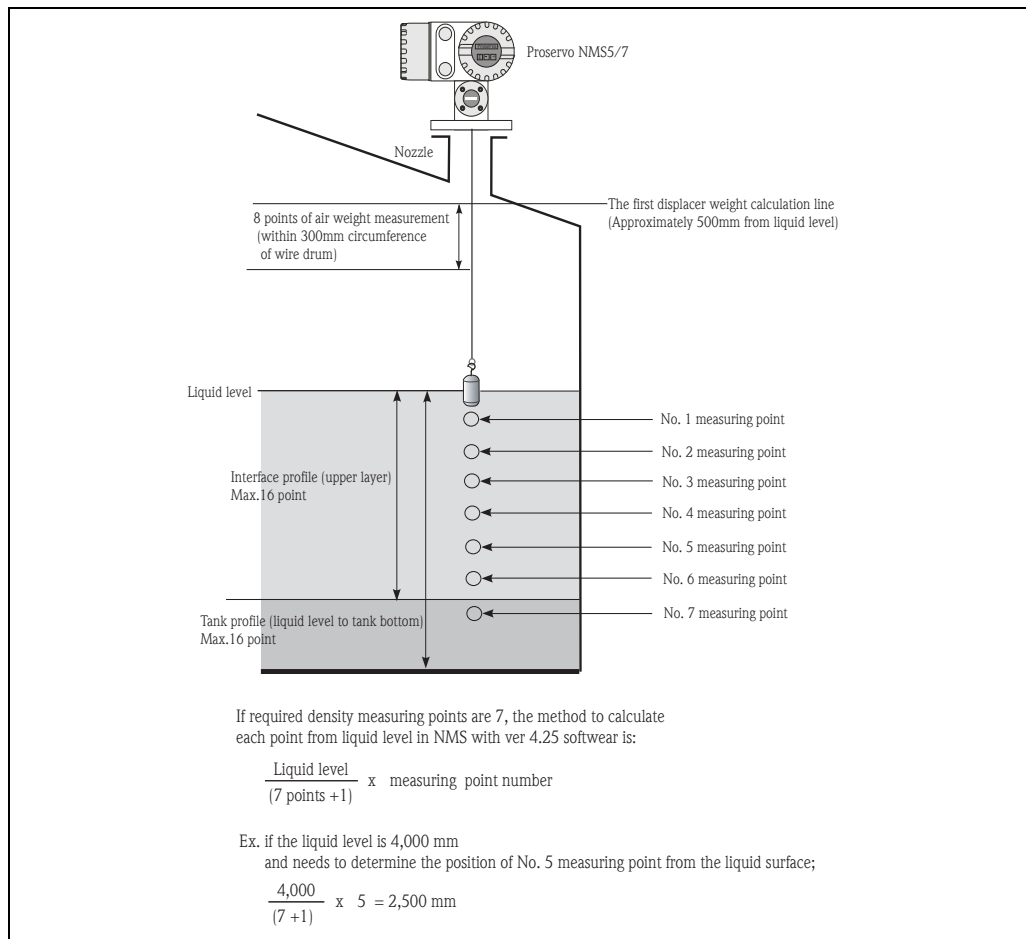

Operation procedure

1. Operation status with level measurement
2. Displacer raises & weights in the air at 8 points
3. Density measurement at programmed position in the liquid
4. Returns to level measurement
5. Data stored in G8 matrix accordingly

Caution!

The average density & temperature data regarding density profile function (G8 Matrix) are completely different from the data on G0 static matrix which displays the conventional upper density (spot) & temperature (continuously scanned) data.

7.7 Interface Measurement

Proservo NMS5/7 can measure interface levels via the following operations:

- Upper Interface Level: returns the level data for the interface between top 2 liquid phases. Displacer remains at interface level in UPPER INTERFACE operation.
- Middle Interface Level: returns the level data for the interface between bottom 2 liquid phases. Displacer remains at interface level in MIDDLE INTERFACE operation.
- Water Dip: returns the level data for the interface between top 2 liquid phases. Displacer returns to liquid level in LEVEL operation.

The following preconditions are required in order to assure safe and accurate operation.

- Density values:

- Upper Density < Middle Density < Bottom Density
- Middle Density - Upper Density \geq 0.100 g/cm³
- Bottom Density - Middle Density \geq 0.100 g/cm³

e.g. 0.760 g/cm ³
e.g. 0.880 g/cm ³
e.g. 0.1000 g/cm ³

(Example)

Density values can be viewed and changed at the following matrix positions:

G0V0H5 Upper Density
 G0V0H6 Middle Density
 G0V0H7 Density Bottom

Note: Additional matrix parameter settings are required for remote communications via WM550 communications protocol.

Refer to Section 11. "Matrix, (Dynamic Matrix, Device Data : G2), WM550 ALM. SELECT."

Operation:

After confirming the above pre-conditions, use the "+" or "-" keys to select the desired operation at matrix position G0V2H0 OPERATION. When the desired operation is displayed, press the "E" key.

7.8 Sealing of the Proservo

The Proservo NMS5/7 can be sealed, and data can be made unchangeable for custody transfer purposes as follows.

Set OPE. DENSITY at position GVH=278 as the density of the liquid. (If the density is expected to change during operation, then set the average value.)

Turn off the power supply, open the Proservo.

Turn the micro switch to "on position" on the printed circuit board TCB (see figure below). The Proservo will then set "write-protect" mode and not accept any change of level, weight, and density data.

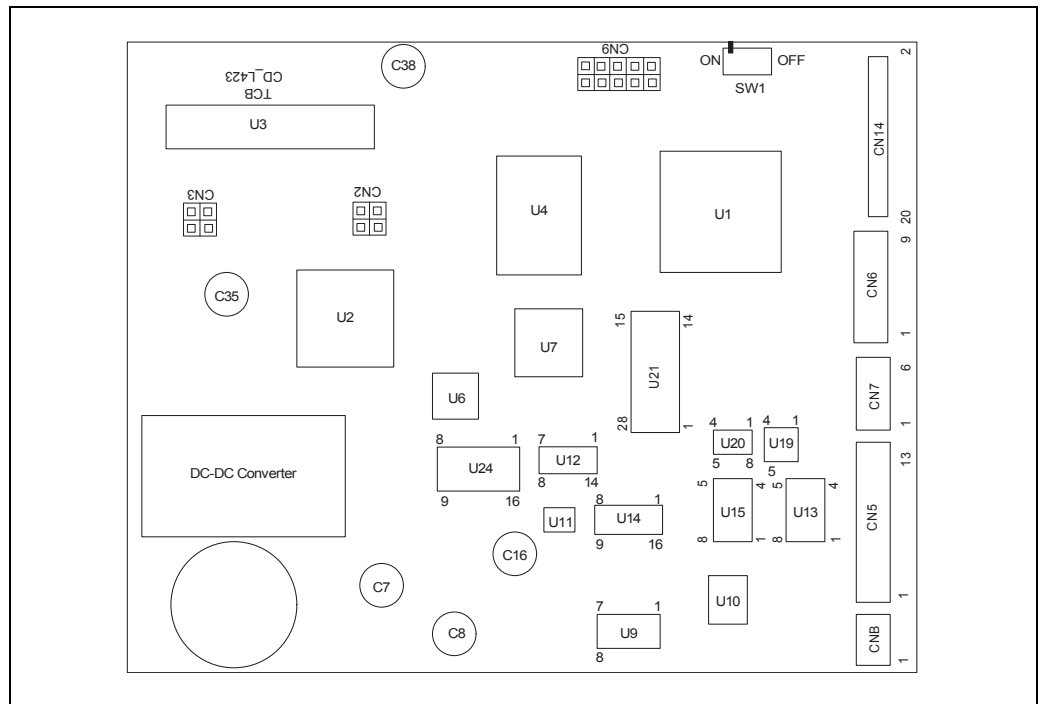

the printed circuit board TCB

8 Diagnosis and Troubleshooting

The Proservo NMS5/7 has a superb self-diagnosis function that monitors its operation. If an error has occurred, the corresponding message is displayed on the LCD. The selected matrix position and the error message are displayed every few seconds alternatively. Data can be accessed while the selected matrix position is displayed. The error messages are stored in the memory of the Proservo NMS5/7. Matrix position GVH=037 provides the diagnostic history.

8.1 Selection of Diagnostic Code and History

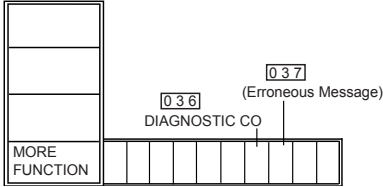
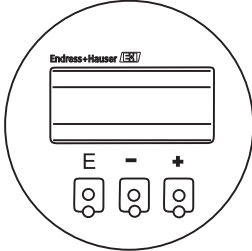
Item	Procedure	Remarks
<p style="text-align: center;">Static Matrix : G0</p>  <p style="text-align: center;">Touch Control</p> 	<ol style="list-style-type: none"> 1) On "MORE FUNCTION" , select item GVH=036 "DIAGNOSTIC CO." 2) Previous static matrix records are sequentially displayed in Static Matrix screen GVH=037, starting with the latest record. Up to 100 alarm records can be saved. If the number of records exceeds 100, it is sequentially overwritten starting with the oldest record. For example, 973192238 2402 means that an error occurred at 22:38 on March 19, 1997, when the instrument temperature was 24 °C and this is the second error since Proservo was installed. Display includes the year, month, day, hour, minute, instrument temperature, and an error sequential number, in this order. 	<ul style="list-style-type: none"> ■ Item GVH=037 only shows error message, calendar, and pointer, but no label on the LCD.

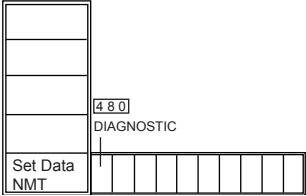
Item	Procedure	Remarks
<p style="text-align: center;">Temperature Matrix: G4</p> 	<ul style="list-style-type: none"> ■ NMT temperature sensor last diagnostic is displayed at G4V8H0 DIAGNOSTIC 	

8.2 Error and Status Messages

Message	Cause	Remedy	Error code
-49.5 °C	Indication of shorted element in NMT temperature sensor.	Check GVH=450 thru GVH=459 to see element.	
358.0 °C	Element is not enabled, or not installed in NMT temperature sensor .	Check GVH=482 Total number of elements	
359.0 °C	Indication of open element in NMT temperature sensor.	Check GVH=450 thru GVH=459 to see element.	
ADC/SENSOR ERROR	The signal from the A/D converter is out of range.	Consult E+H Service.	107
ADJ. XXXCOUNTER (X=A, I, Z or combination)	Error of level data check by A, I, and/or Z phase encoder.	If the message appears frequently, then consult E+H Service.	
A PHASE NO INPUT	The input of the A phase signal from the encoder is not available.	Replace the detector unit. Consult E+H Service.	122
BELOWBOT. POINT	Indicates NMS displacer position is below lowest of NMT temperature sensor.		
DEVICE ERROR: DEV 1 (or 2)	The HART® device 1 (or 2) gives an error signal.	Check the HART® device 1 (or 2) .	130, 131
DEVICE ERROR: NMT	The Promonitor NMT 53x gives an error signal.	Check the connection of the Prothermo NMT 53x. Check the register of the temperature sensor at position GVH=362 "CONNECTION NMT."	250
DEVICE ERROR: NMT	The Prothermo NMT 53x temperature sensor is not available.	Check the Prothermo NMT 53x. Error messages are available in the Prothermo NMT 53x manual.	233
DEVICE ERROR: NRF	The Promonitor NRF 560 gives an error signal.	Check the Promonitor NRF 560. Error messages are available in the Promonitor NRF 560 manual.	240
DISPL CALIB ERROR	The deviation of automatic weight calibration exceeds its set limit.	Check build-up or deposit on the displacer.	120
ELEM 0 RANGE OVER	Indicates the reference resistance element (°C) on NMT electronics is out-of- tolerance.		
IMPOSSIBILITY	Operation is impossible because there is no weight table.		
LOCAL ERROR: DEV1 (or 2)	The Proservo cannot access the local HART® device 1 (or 2)	Check the connection of the HART® device to the Proservo. Check the registration of the device(s) in matrix group G5/6.	232
LOCAL ERROR: NMT	The signal from the Prothermo NMT 53x temperature sensor is not available.	Check the connection of the Prothermo NMT 53x. Check the register of the temperature sensor at position GVH=362 "CONNECTION NMT."	111
LOCAL ERROR: NRF	The Proservo cannot access the Promonitor NRF 560 tank side monitor.	Check the connection of the Promonitor NRF 560 and register of the tank side monitor at position GVH=361 "CONNECTION NRF."	113
MINTENANCE	GVH157 Service Mode = ON	Set GVH157 = OFF	199
MEM. ERROR	Defect in the memory that is specially used for custody transfer sealing.	Replace the CPU board. Consult E+H Service.	201
MPU RESET	Power to the CPU module fell below minimum value.		
MPU: START ACT*	Power to the Proservo was turned OFF/ON.	If the message occurs frequently, then consult E+H Service.	

Message	Cause	Remedy	Error code
OVERTENSION	The tension on the measuring wire exceeds the upper limit set at position GVH=162 "OVER TENS. SET."	Check if the displacer motion is blocked by clogging or sticking. To release overtensioning, access position GVH=371 "RELE. OVER TENS."	101
POWER FAILURE	The supply voltage falls below the allowed value.	Check the power source.	124
RAM FAILURE	CPU RAM failure		
ROM ERROR	EEPROM	Consult E+H Service.	132
SIFA ERROR	Error between communication board and CPU board for digital output.	Replace the CPU board. Consult E+H service.	114
TEMP BELOW RANGE	Indicates the measured temperature data is below the fixed range of the NMT temperature sensor.		
TEMP COM OPEN	Indicates an open common line in the NMT temperature sensor		
TEMP COM SHORT	Indicates a shorted common line in the NMT temperature sensor		
TEMP OVER RANGE	Indicates the measured temperature data is higher than the fixed range of the NMT temperature sensor.		
UNDERTENSION	The tension on the measuring wire falls below the lower limit set at position GVH=163 "UNDER TENS. SET."	Check if the measuring wire is cut or the displacer is lost. In this case, check the installation of the Proservo.	102
WIRE CALIB ERROR	The deviation of automatic wire calibration exceeds its set limit.	Check wire and wire drum.	115
Z PHASE NO INPUT	The input of the Z phase signal from the encoder is not available.	Replace the detector unit. Consult E+H Service.	106, 112
MPU:XXXX* (XXXX=text)	CPU error	The error might happen occasionally and might be registered in GVH=037 (Erroneous Message). However, it is normally negligible. If it occurs frequently, then consult E+H Service.	
OPE.CODE ERROR	An illegal operation command is accessed.	If the message occurs frequently, then consult E+H Service.	
LCD CHECK	Error between LCD (touch control) unit and CPU board for digital output.	Replace the touch control.	121
GAUGE TEMP.	The temperature inside the gauge exceeds the limit.	Check if the ambient temperature stays within the limit. If the application is a high temperature tank, then take measures to avoid heat transfer from the tank to the Proservo.	

*These error histories are available (Erroneous Message) at position GVH=037.

8.3 Diagnostics and Troubleshooting: Flowcharts

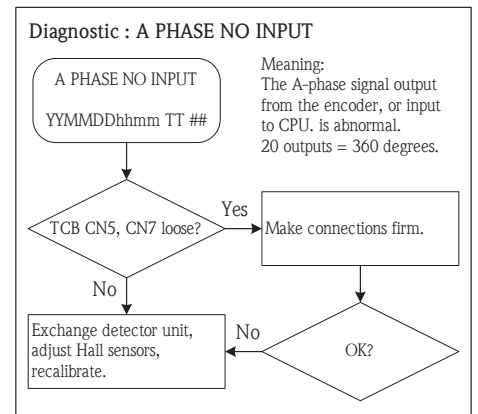
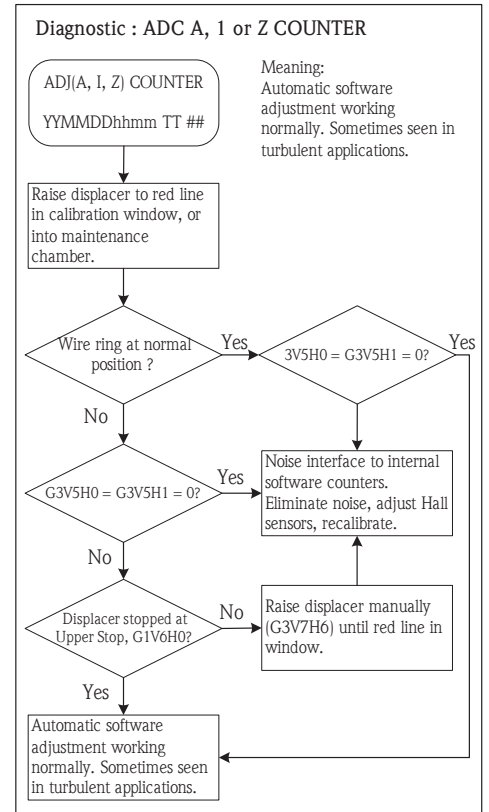
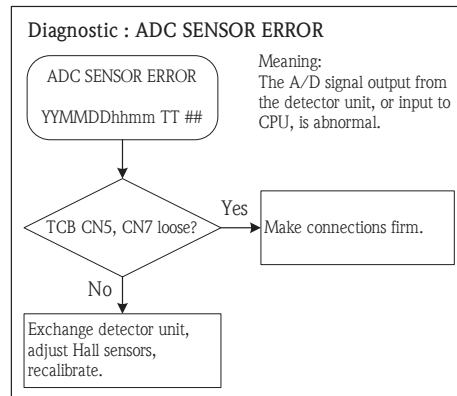
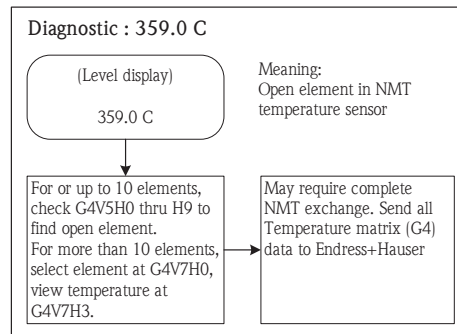
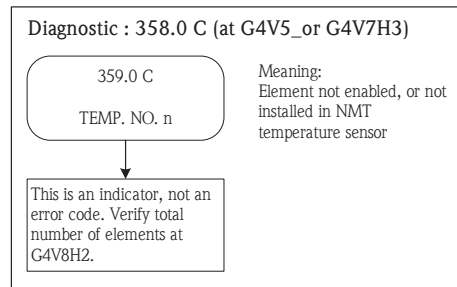
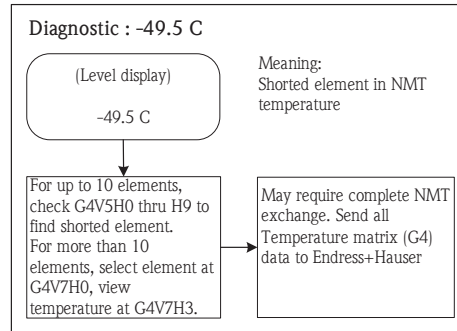

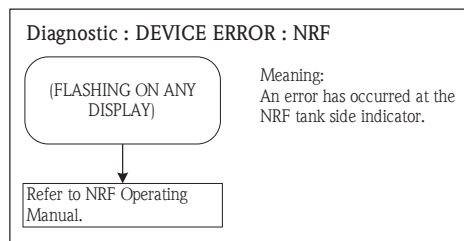
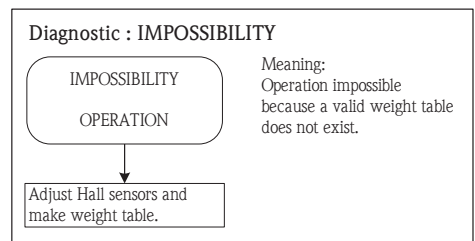
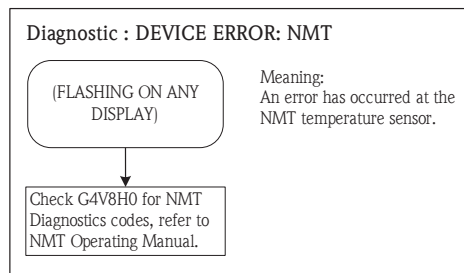
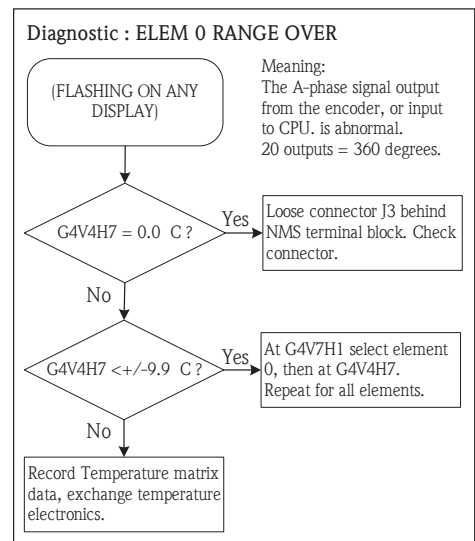
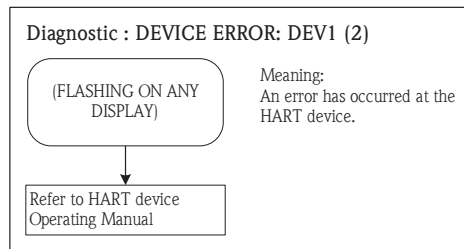
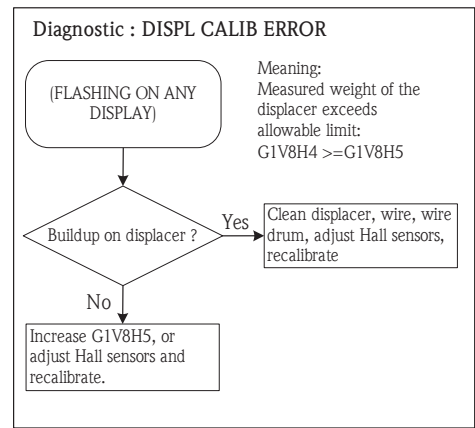
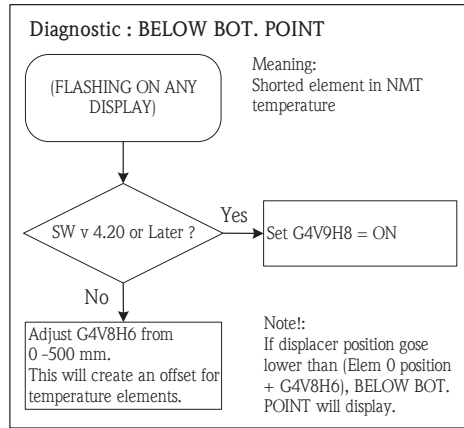

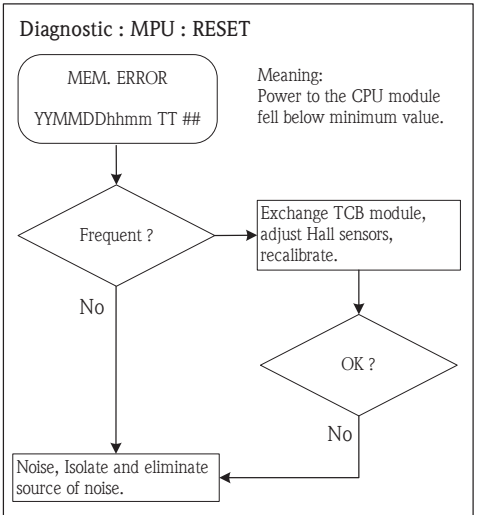
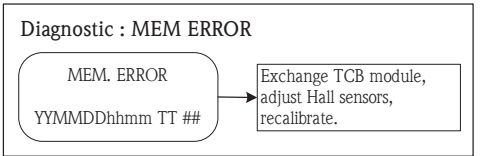
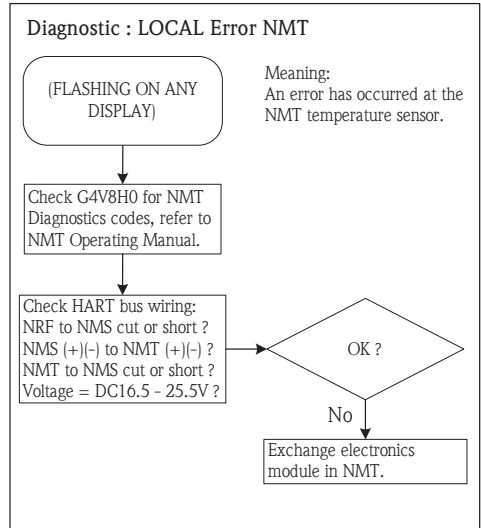
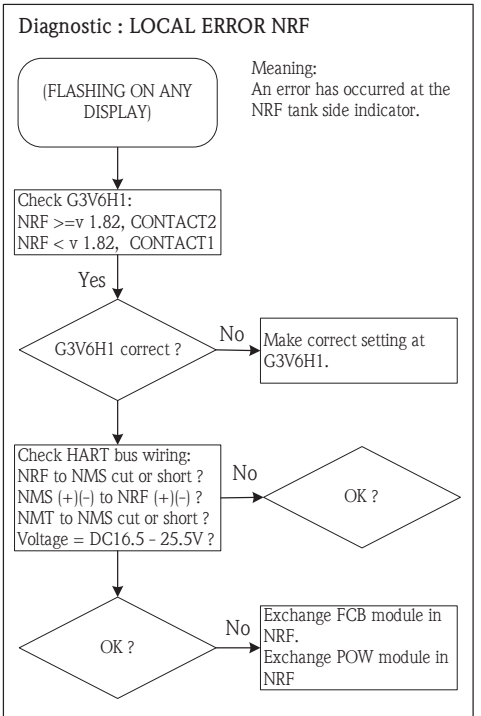
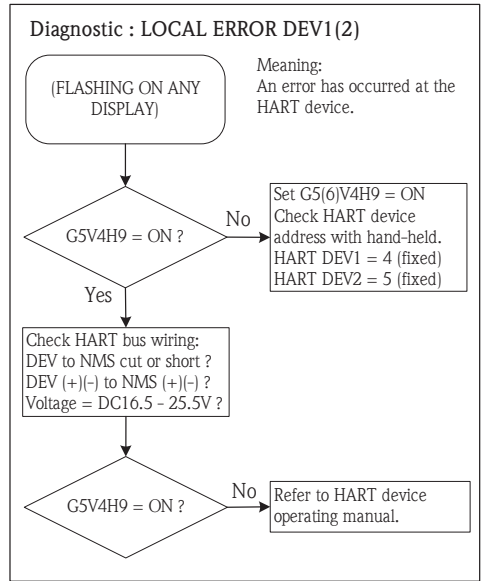

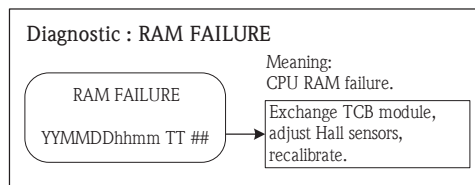
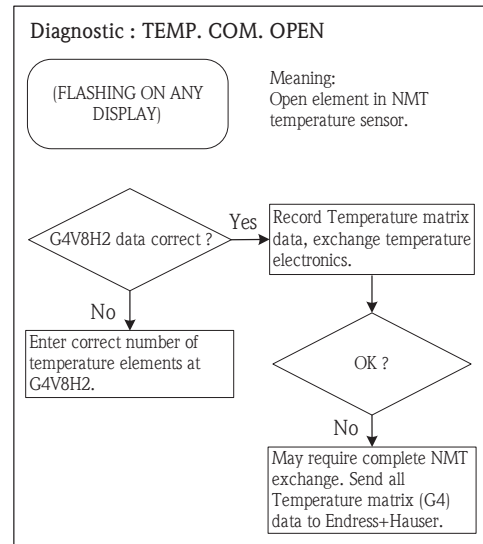
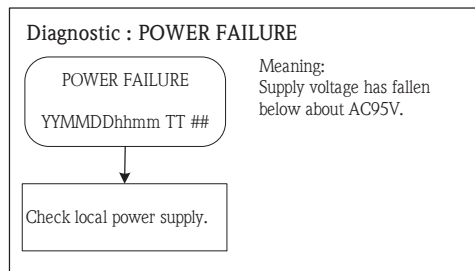
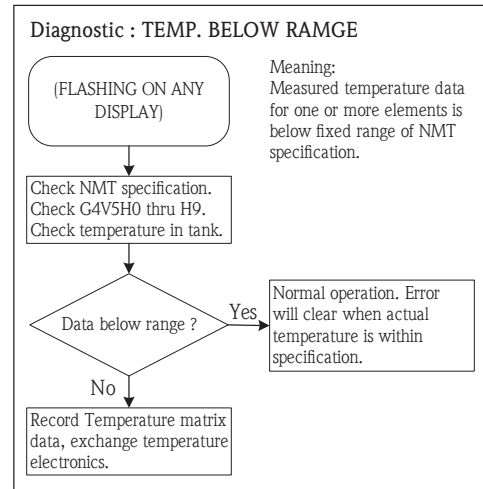
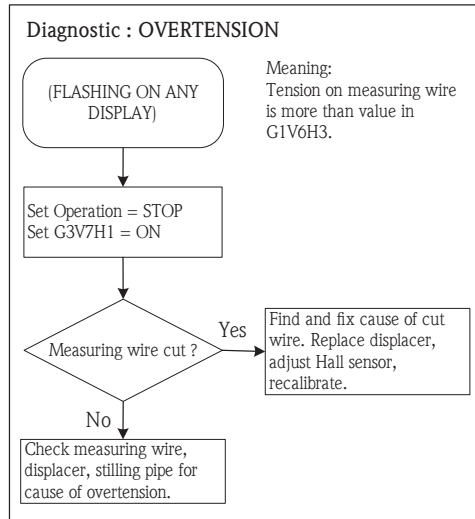
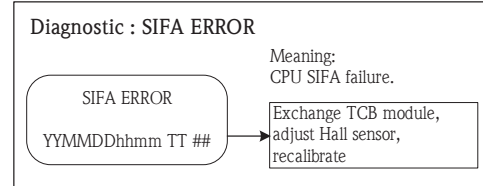
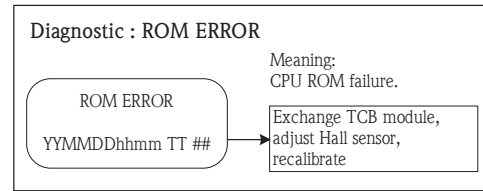
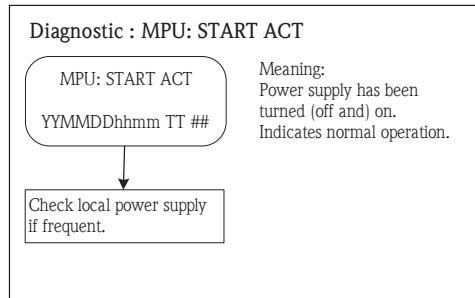

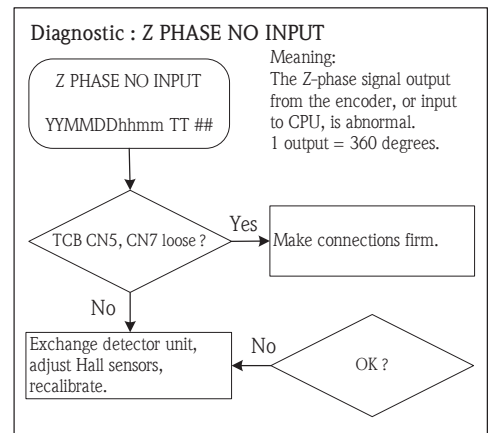
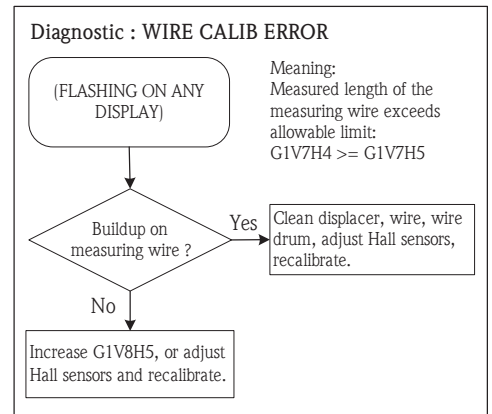
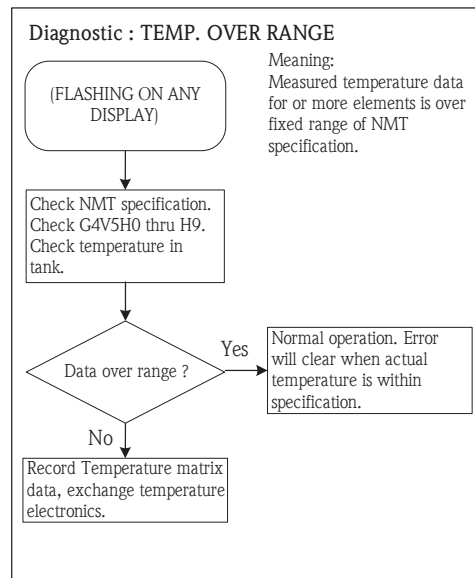
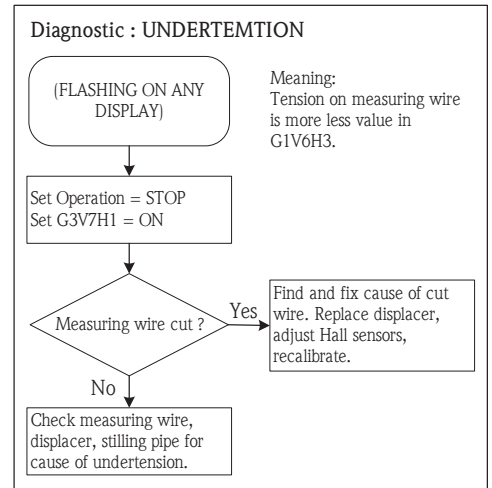
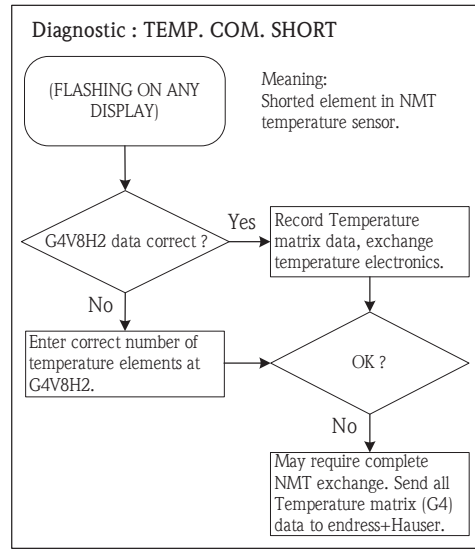

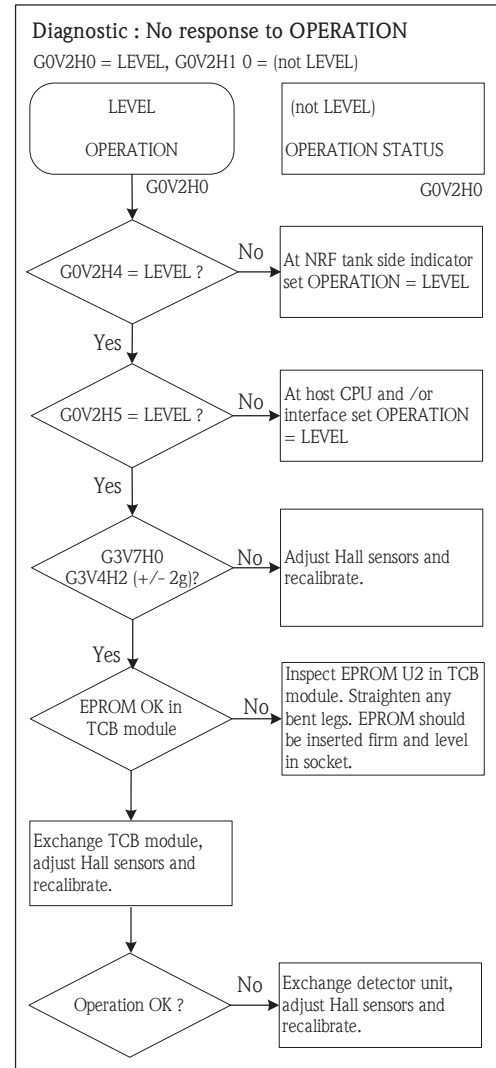
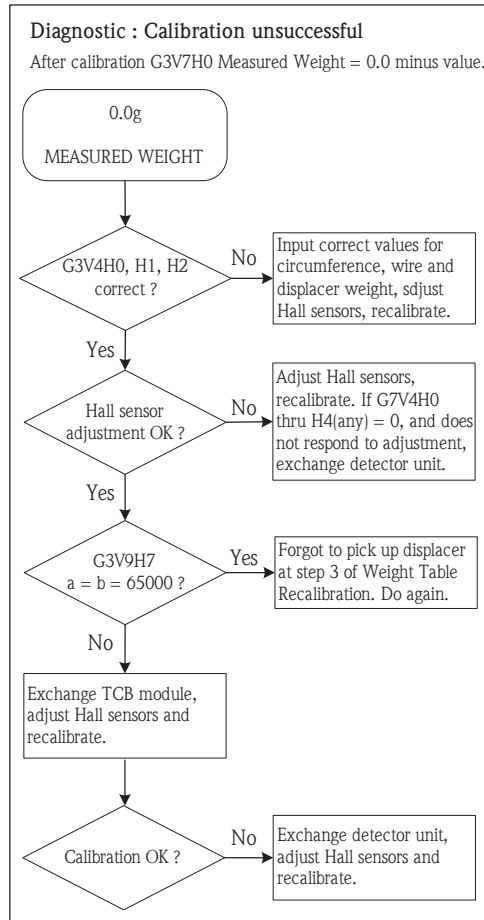

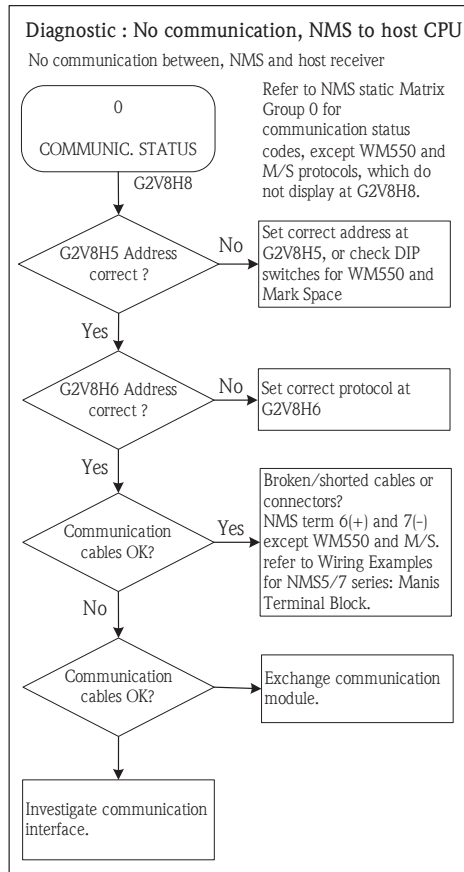

8.4 Setting after parts replacement

After any part of the Proservo NMS5/7 has been replaced, and before starting the Proservo NMS5/7 calibration, specify the data on the following equipment.

- Circumferential length of the wire drum (indicated on face of wire drum)
- Weight of the displacer (indicated on the body of the displacer)
- Volume of the displacer (indicated on the body of the displacer)
- Balance volume (indicated on the body of the displacer or 50% of volume)
- Density of measured liquid (up to three phases)
- Height of the tank with the Proservo NMS5/7 mounted on it (refer to Section 7).

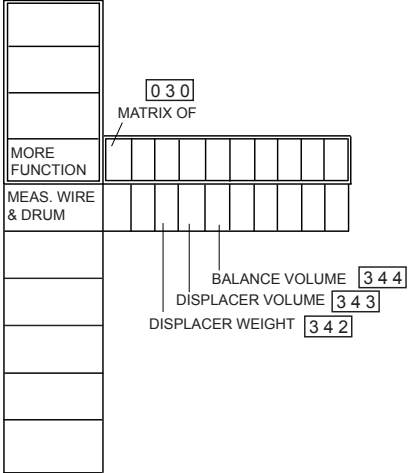
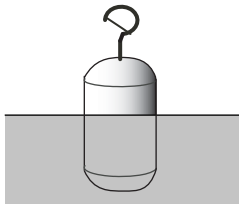
Item	Procedure	Remarks
<p style="text-align: center;">Matrix Group: SERVICE</p>	<ol style="list-style-type: none"> 1. In Static Matrix "MORE FUNCTION" bring up GVH=030 "MATRIX OF" and select "SERVICE". 2. Select Dynamic Matrix GVH=340 "WIRE DRUM CIRC." Check whether the displayed value is equal to the value marked on the wire drum. If not, adjust the displayed value. 	<ul style="list-style-type: none"> ■ Set the access code at 51.
<div style="display: flex; align-items: center;">  <div style="margin-left: 20px;"> <p>0 3 0 MATRIX OF</p> <p>MORE FUNCTION</p> <p>MEAS. WIRE & DRUM</p> <p>BALANCE VOLUME 3 4 4</p> <p>DISPLACER VOLUME 3 4 3</p> <p>DISPLACER WEIGHT 3 4 2</p> </div> </div> <p>Note! The weight and volume of the displacer are marked on its bottom.</p>  <p>The balance volume is the volume of that part of the displacer that is immersed in the liquid when the displacer is balanced in the liquid.</p>	<ol style="list-style-type: none"> 1. Select the Dynamic Matrix screen GVH=341. 2. Set Dynamic Matrix GVH=342 "DISPLACER WEIGHT" at the value marked on the displacer. 3. Set Dynamic Matrix GVH=343 "DISPLACER VOLUME" to the value marked on the displacer. 4. Set Dynamic Matrix GVH=344 "BALANCE VOLUME" at half the value set in "DISPLACER VALUME." "This setting is provided to approximate the position of the displacer when it becomes stationary in the liquid. 	<ul style="list-style-type: none"> ■ For calculation methods of the draft position.

8.5 Intelligent Function

8.5.1 Measured Wire Length Calibration

After sustained periods of operation, measured liquid objects may be deposited on the wire or the wire drum, resulting in measurement errors. Therefore, periodically check the wire and the wire drum.

- At screen GVH=175 "COMPENS. LIMIT", an error message will be displayed on the LCD screen.
- (Not available with Weight & Measures specification.)

8.5.2 Displacer Weight Calibration

After sustained periods of operation, measured liquid deposited on the displacer increase the displacer's weight, resulting in errors. Thus, periodically, or arbitrarily, hoist the displacer and select GVH=180 "CALIBR. AUTO/MAN" and then invoke "AUTOMATIC", the weight of the displacer will be measured and calibrated. "MANUAL" can be selected for overwriting (the recommended value is 10.0g).

- If the difference between the initial measured value of the weight of the displacer and the current measured value is within the tolerance set in GVH=185 "COMPENS. LIMIT", the Proservo automatically corrects the weight during level measurements.
- If the difference between the initial measured value of the weight of the displacer and, the current measured value, is beyond the tolerance, an error message is displayed on the LCD screen.
- (Not available with Weight & Measures specification.)

8.5.3 Maintenance Prediction Function

The history of maintenance is displayed on the Matrix screen GVH=265 "(Parts Overused Date)." The LCD screen displays the following contents.

- Total operation time for parts managed according to this value
- Total number of rotations of the wire drum for parts managed according to this value

Reference Part Management Value		
Display	Part	Reference (conducting time/ number of rotations)
1) POWER UNIT	Power supply unit	43,800 hours (about 5 years)
2) DISPLAY UNIT	LCD indicator	61,300 hours (about 7 years)
3) MOTOR UNIT	Motor/driver unit	43,800 hours (about 5 years)
4) WIRE UNIT	Measuring wire	240,000 rotations
5) BEARINGS UNIT	Drum bearing metal	145,000 rotations
6) SHAFT UNIT	Drum shaft	240,000 rotations

8.6 Spare Parts

Spare parts are contained in kits. Spare parts which you can order from Endress+Hauser for the Proservo are shown with their order numbers in the diagram below. For more information on service and spare parts, contact Endress+Hauser.

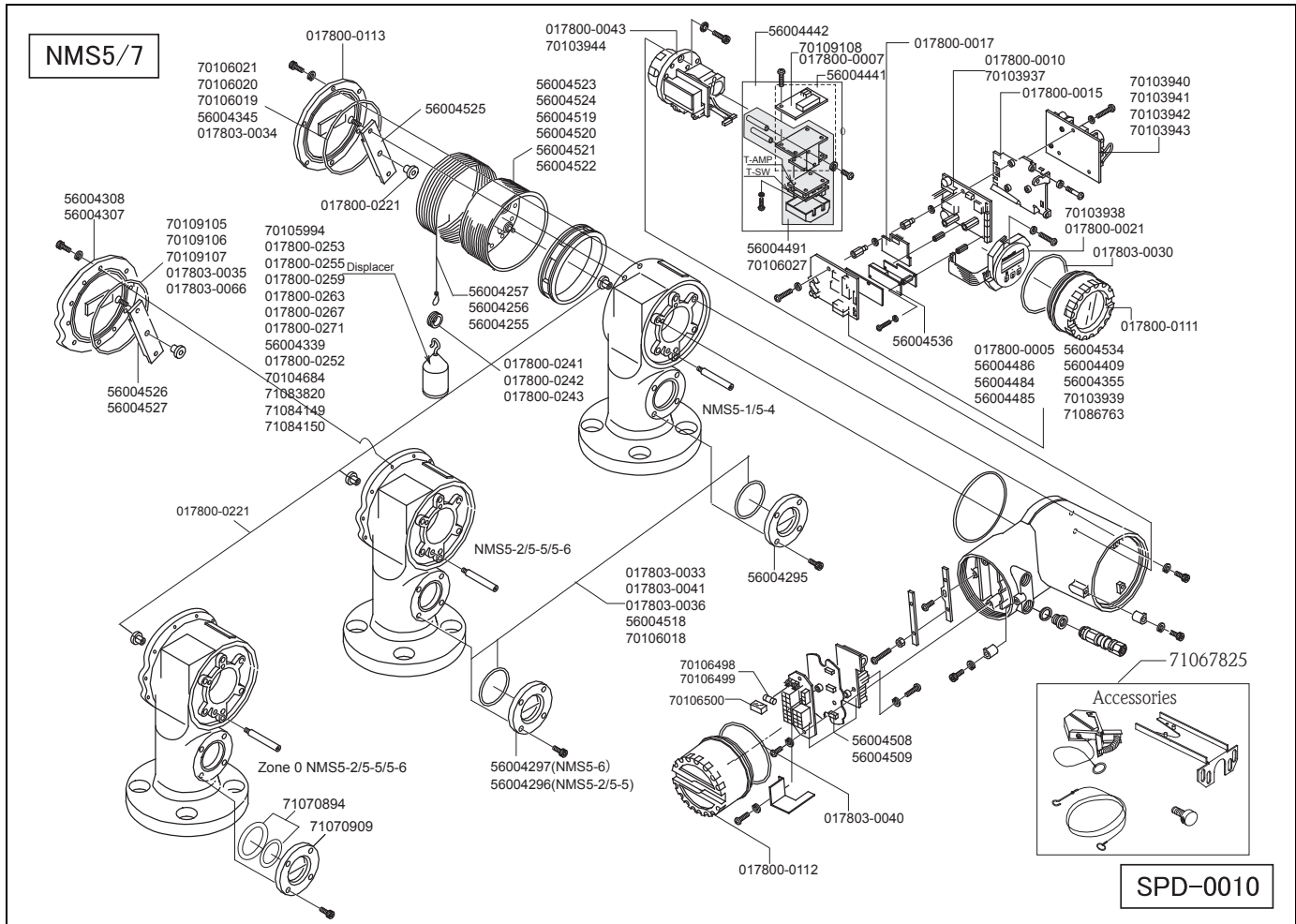

Spare parts

Order code list

Order code		Parts name	*Please see Service Manual	
Order code	Parts name	Order code	Parts name	
O-Ring			52013649	Enraf BPM Up Grade kit
017803-0034	O-Ring, Alu drum cover, NBR	Aluminum drum housing	52013656	I/O Up Grade kit
70106021	O-ring D120-d3 Silicon		52013654	I/O 3 Up Grade Kit
70106020	O-ring D120-d3 FPM		70106035	Oper. I./C.O., Exd upgrade kit
70106019	O-ring D120-d3 CR		56004490	SPOT TEMP. INPUT T-AMP UP GRADE KIT
56004345	DRUM HOUSING COVER, O-RING, PTFE		70106032	Oper. I./C.O., carrie upgrade kit
017803-0066	O-Ring, St., St. drum cover, Flourine rubber	SC, SE drum housing	Cable	
017803-0035	O-Ring, St., St. drum cover, Silicon rubber		52013660	Terminal Block V1 COM1/RB, RS485 module cable
70109105	O-Ring, D158-d3.5, NBR		52013650	Terminal Block HART module cable
70109107	O-Ring, D158-d3.5, CR		70106037	Terminal Block HART Active module cable
70109106	O-Ring, D158-d3.5, PTFE		52013657	Terminal Block Mark Space/WM550 w. Arrester module cable
017803-0033	O-Ring, window glass (G60), NBR	Calibration window	52013648	Terminal Block Enraf BPM module cable
017803-0041	O-Ring, window glass (G60), Silicon rubber		52013655	Terminal Block I/O 5 module cable
56004518	Window glass (G60), O- Ring, PTFE		52013653	Terminal Block I/O 3/ module cable*
70106018	O-ring D60-d3 CR		52013652	I/O 3/ CPU cable*
017803-0036	O-Ring, window glass (G60), Flourine rub.		70106036	Terminal Block COM-4 module cable
017803-0030	O-Ring, display cover, NBR	70106033	CPU+T-AMP Ex d module cable*	
017803-0040	O-ring, D123.5-d3.5, NBR	70106034	Terminal Block T-AMP Ex d module cable*	
Module			70105996	Terminal Block T-AMP Ex ia module cable
017800-0005	V1 Communication module / COM-1		70105995	CPU+T-AMP Ex ia module cable
56004486	RS-485 RACKBUS MODULE	Detector & Power module		
70103939	RS-485 MODBUS MODULE	017800-0043	Detector unit NMS (TCC-3)	
71086763	RS-485 MODBUS MODULE COM-5	70103944	Detector unit NMS (TCC-3 Ver.1)	
56004484	REMOTE HART MODULE/PASSIVE	70103940	POW-6 HV non Ex i	
56004485	REMOTE HART MODULE/ACTIVE	70103941	POW-6 LV non Ex i	
56004534	WM550 COMM. MODULE WITH ARRESTOR	70103942	POW-6 HV Ex i	
56004409	MARK/SPACE COMM. MODULE	70103943	POW-6 LV Ex i	
56004355	ENRAF BPM COMM. MODULE COM-3	017800-0021	Display module proservo, 3 key optical	
017800-0017	4...20mA output / I/O-5 (for TCB-4)	70103938	Display+Operation module type II	
017800-0007	Alarm out (4 contacts)I/O-3	017800-0015	PCB(CPU) Carrier set/compl.(incl.spacer)	
70109108	Alarm out (2 contacts) I/O-3 TÜV	Displacer		
56004356	EXI HART/CONTACT OUT WITH CARRIER	017800-0259	Displacer, cylindrical, dia=30mm, SUS316	
56004442	OPE INPUT/CONTACT OUT+SPOT TEMP.+CARI	017800-0255	Displacer, cylindrical, dia=40mm, SUS316,	
56004491	SPOT TEMP. WITH CARRIER	017800-0252	Displacer, cylindrical, dia=50mm, SUS316 Standard	
56004441	Ope Input / Contact out with carrier	56004339	Displacer with ring 50D	
70106027	Ex[ia] Spot Temp. with carrier	017800-0253	Displacer, conical, dia=50mm, PTFE	
56004508	Terminal & Noise Filter Ex d	70105994	Displacer, cylindrical, dia=50mm, PTFE	
56004509	Terminal & Noise Filter Ex d[ia]	017800-0271	Displacer, cylindrical, dia=50mm, Hastelloy C	
Up grade Kit		017800-0263	Displacer, conical, dia=70mm, SUS316	
52013661	V1 Up Grade Kit	017800-0267	Displacer, conical, dia=110mm, SUS316	
70106270	RS485 Modbus up grade kit	70104684	Displacer, conical, dia=110mm, SUS316, High pressure	
52013651	HART Up Grade Kit	71083820	Displacer, cylindrical, dia=50mm, SUS316, zone0	
70106039	HART active upgrade Kit	71084149	Displacer, cylindrical, dia=70mm, SUS316, zone0	
52013662	WM550 Up Grade Kit	71084150	Displacer, cylindrical, dia=110mm, SUS316, zone0	
52013658	Mark Space Up Grade Kit			

Order code	Parts name	Order code	Parts name
Wire drum+Wire		Other Parts	
56004521	Wire Drum + Measuring wire (10M)	56004295	Calibration Window Alu (NMS531)
56004519	Wire Drum + Hasteloy wire (10M)	56004296	Calibration Window St./St. (NMS531)
56004522	Wire Drum + Measuring wire (10,16M)	56004297	Calibration Window St./St. (NMS536)
56004524	Wire Drum + Teflon wire (16M)	71010909	Calibration Window Zone 0
56004520	Wire Drum + Hasteloy wire (16M)	71070894	Packing+ring, calibration window Zone 0
56004523	Wire Drum + Measuring wire (28M)	70106498	Fuse 250VAC (T2A50) 10sets, NMS
56004257	5 set 28M Measuring wire (0.15) SUS316	70106499	Fuse 20-62VDC (T3A15) 10sets, NMS
56004256	5 set 16M Measuring wire (0.4) PTFE	70106500	Fuse Cover 10sets, NMS
56004255	5 set 28M Measuring wire (0.4) Hasteloy C		
017800-0241	Wire ring (SUS316)		
017800-0242	Wire ring (PTFE coated)		
017800-0243	Wire ring (Alloy C)	71067825	50g Calibration weight
56004525	Wire Drum Bracket Alminum		
56004527	Wire Drum Bracket Stainless Steel		
56004526	Wire Drum Bracket St./St. Teflon Coat		
017800-0221	Medal for drum housing (x2) - PTFE		

9 Displacer and Measuring Wire

9.1 Shape, Diameter, and Material

Displacer

There are several types of displacer available for the Proservo NMS5/7:

- The standard type has cylindrical shape and a diameter of 50 mm. Diameters from 30 to 50 mm are optional.
- Cylindrical shape is used for viscous liquids. It is also effective if the stilling well is not smooth on its interior surface.

Displacer weight and volume depend on the application. Thin displacers are suited for level measurement, thicker ones for bottom level, interface level, and density measurement.

A counterweight is optional for heavy turbulence (please inquire).

Displacers of three different materials are provided:

- The standard material is stainless steel SUS316.
- Alloy C and PFA are optional for corrosive liquids.
- Solid PFA, however, is not applied for flammable liquids.

The following size of displacer will be supplied, when you order custody transfer approval.

Note!



NMi (Netherlands).....Ø70mm

PTB (Germany).....Ø110mm

Measuring wire

- The standard material of the measuring wire is stainless steel SUS316 (Ø0.15 mm).
- Hastelloy C (Ø0.20 mm) and PFA coated stainless steel SUS316 (Ø0.4 mm) are for corrosive liquids.

The following specification of measuring will be supplied, when you order the custody transfer approval.

Note!



SUS316 (Ø0.15 mm) for NMi and PTB.

9.2 Alarm History Display

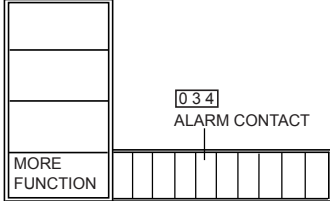
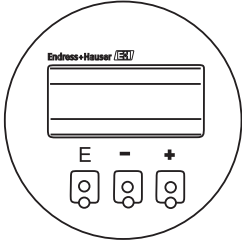
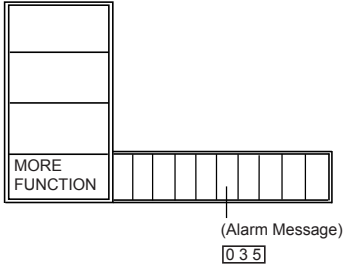
Item	Procedure	Remarks
<p>Matrix Group: DEVICE DATA</p>  <p>Touch Control</p> 	<p>1. Bring up Static Matrix GVH=034 *ALARM CONTACT."</p>	
<p>Static Matrix</p> 	<p>2) Previous static matrix records are sequentially displayed in Static Matrix screen GVH=035, starting with the latest record. Up to 100 alarm records can be saved. If the number of records exceeds 100, it is sequentially overwritten starting with the oldest record. The display includes the year, month, day, hour, minute, instrument temperature, and an error sequential number, in this order. For example, 97 3192238 2402 means that an error occurred at 22:38 on March 19, 1997, when the instrument temperature was 24 °C and this is the second error since Proservo was installed.</p>	

9.3 List of Alarm Messages

MESSAGE	Cause of Alarm
UPPER LIMIT LEVEL	The level has risen above the set alarm operation value.
LOWER LIMIT LEVEL	The level has fallen below the set alarm operation value.
UPPER LIMIT TEMP.	The temperature has risen above the set alarm operation value.
LOWER LIMIT TEMP.	The temperature has fallen below the set alarm operation value.

9.4 Initial Weight Calibration

9.4.1 Displacer Weight calibration

Weight table calibration must be done after Hall sensor adjustment. Use this procedure for NMS5/7 with level measurement function only.

Note!





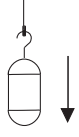

Wind and vibration affect weight table calibration.

Not necessary to make Initial Calibration for Startup "All-in-one" (displacer attached) shipments.

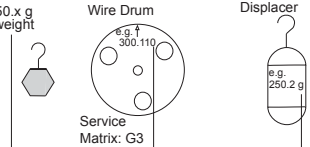
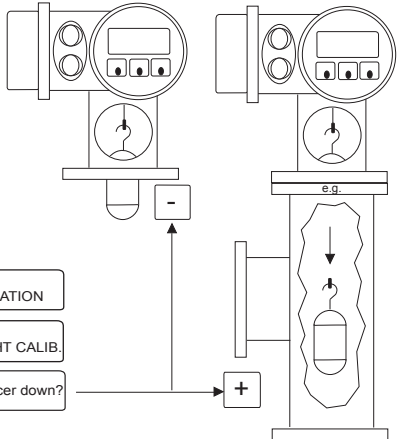
Item	Procedure	Remarks								
<p>Weight table calibration, Basic.</p> <p>1)</p> <div style="display: flex; justify-content: space-around;"> <div style="text-align: center;"> <p>Wire Drum</p> </div> <div style="text-align: center;"> <p>Displacer</p> </div> </div> <div style="margin-top: 10px;"> <table border="1" style="border-collapse: collapse; text-align: center;"> <tr> <td style="padding: 2px;">H</td> <td style="padding: 2px;">0</td> <td style="padding: 2px;">1</td> <td style="padding: 2px;">2</td> </tr> <tr> <td style="padding: 2px;">V</td> <td style="padding: 2px;">xxx.xxx</td> <td style="padding: 2px;">x.xx</td> <td style="padding: 2px;">xxx.x</td> </tr> </table> </div> <div style="margin-top: 10px;"> <div style="border: 1px solid black; padding: 2px; display: inline-block;">51 ACCESS CODE</div> </div>	H	0	1	2	V	xxx.xxx	x.xx	xxx.x	<p>1. Enter Access Code 51 confirm the following data.</p> <p>G3V4H0 wire Drum Circum.(engraved on wire drum)</p> <p>G3V4H1 Wire Weight Standard SUS = 1.40 PFA=4.55</p> <p>Hastelloy=2.48</p> <p>G3V4H2 Displacer Weight (engraved on displacer)</p>	
H	0	1	2							
V	xxx.xxx	x.xx	xxx.x							
<p>2)</p> <div style="display: flex; justify-content: space-around;"> </div>	<p>2) Displacer is in calibration window or maintenance chamber.</p> <p>Set Operation = STOP</p> <p>Set G3V7H9=0.0</p> <p>Set G3V7H2=ON</p> <p>At "Displacer Down? +/-" enter NO(-). However. for maintenance chamber enter Yes (+).</p>									
<p>3)</p> <div style="display: flex; align-items: center;"> <div style="border: 1px solid black; padding: 2px; margin-right: 10px;">2xxxx 1xxxx 0.0 Low on: E& -</div> <div style="margin-right: 10px;">E</div> <div style="margin-right: 10px;">-</div> <div style="text-align: center;"> </div> </div>	<p>3) Left displacer until Sa and Sb are stable. Press "E" and (-) keys together. Release displacer.</p>									

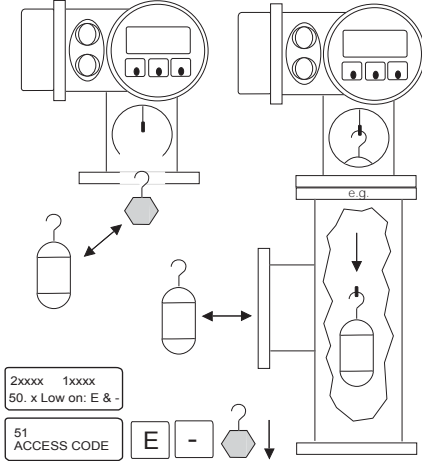
Item	Procedure	Remarks
<p>4)</p> <p>Displacer set: ok? <input type="button" value="E"/></p> <p>Displacer on? E & + <input type="button" value="E"/> <input type="button" value="+"/></p> <p>2xxxx 1xxxx 0.0 Low on: E & -</p> 	<p>4) At "Displacer set ok?" enter "E". At "Displacer on: E & "+", Press (E) and (+) keys together. Automatic calibration begins (about 10 minutes).</p>	
<p>5)</p> <p>2 Table Make? Yes = +, No = - <input type="button" value="-"/></p> <p>OFF WEIGHT CALIB. <input type="button" value="E"/></p>	<p>5) At "2 Table make?" enter No. (-). At "Weight Calibration OFF" enter "E".</p> <p>Check: Does G3V7H0=G3V4H2+/- 2.0 grams? If yes, calibration is done. If no... -make sure there is no vibration during calibration -repeat Hall sensor adjustment and calibration.</p>	*Always enter No(-).

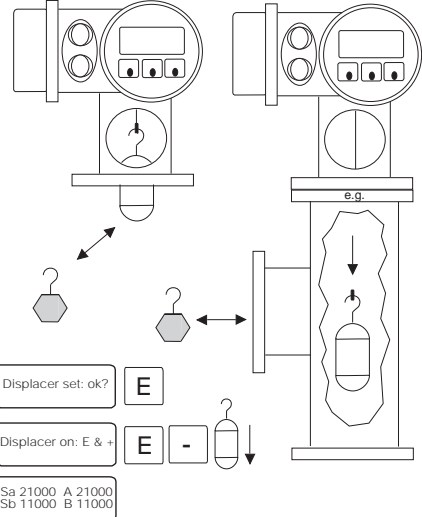
Item	Procedure	Remarks																
<p>Weight table calibration, Density.</p> <p>1)</p> <p>51 ACCESS CODE</p> <p>50.x g weight</p> <p>Wire Drum e.g. 300.110</p> <p>Displacer e.g. 250.2 g</p> <p>Service Matrix: G3</p> <table border="1" data-bbox="662 1377 877 1523"> <tr> <td>H</td> <td>0</td> <td>1</td> <td>2</td> </tr> <tr> <td>V</td> <td>xxx.xxx</td> <td>x.xx</td> <td>xxx.x</td> </tr> <tr> <td>H</td> <td></td> <td></td> <td>9</td> </tr> <tr> <td>V</td> <td></td> <td></td> <td>50.x</td> </tr> </table> 	H	0	1	2	V	xxx.xxx	x.xx	xxx.x	H			9	V			50.x	<p>1) Enter Access Code 51 confirm the following data. G3V4H0 wire Drum Circum.(engraved on wire drum) G3V4H1 Wire Weight Standard SUS = 1.40 PFA=4.55 Hastelloy=2.48 G3V4H2 Displacer Weight (engraved on displacer) G3V7H9 Zero Adjust Weght=50 x g</p>	
H	0	1	2															
V	xxx.xxx	x.xx	xxx.x															
H			9															
V			50.x															
<p>2)</p> <p>STOP OPERATION</p> <p>ON WEIGHT CALIB.</p> <p>Displacer down? <input type="button" value="+"/></p> 	<p>2) Displacer is in calibration window or maintenance chamber. Set Operation = STOP Set G3V7H3 Weight Calib. =ON Set G3V7H9=e.g. 50.0g (test weight, in grams)</p> <p>At "Low weight set?" ... enter No (-), however, for maintenance chamber, enter Yes (+).</p>																	

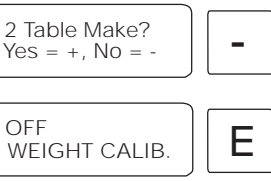
Item	Procedure	Remarks
<p>3)</p>  <p>2xxxx 1xxxx 50. x Low on: E & -</p> <p>51 ACCESS CODE</p> <p>E - </p>	<p>3) Replace displacer with 50 x g weight, stabilize weight. Press "E" and (-) key together.</p>	
<p>4)</p>  <p>Displacer set: ok? E</p> <p>Displacer on: E & + E - </p> <p>Sa 21000 A 21000 Sb 11000 B 11000</p>	<p>4) Replace displacer on wire.</p> <p>At "Displacer on: E & "+", press "E" and (+) keys together.</p> <p>Automatic calibration begins (about 10 minutes).</p>	
<p>5)</p>  <p>2 Table Make? Yes = +, No = -</p> <p>OFF WEIGHT CALIB. E</p>	<p>5) At "2 Table Make?" enter No. (-). At "Weight Calibration OFF" enter "E".</p> <p>Check : Does G3V7H2 +/- 2.0 grams? If yes, calibration is done. If no... -make sure there is no vibration during calibration - repeat Hall sensor adjustment and calibration.</p>	<p>*Always enter No(-).</p>

10 Accessories

10.1 Calibration chamber

Please see Technical Information for NMS.
 NHC4HP: high pressure version
 NHC4LP: low pressure version

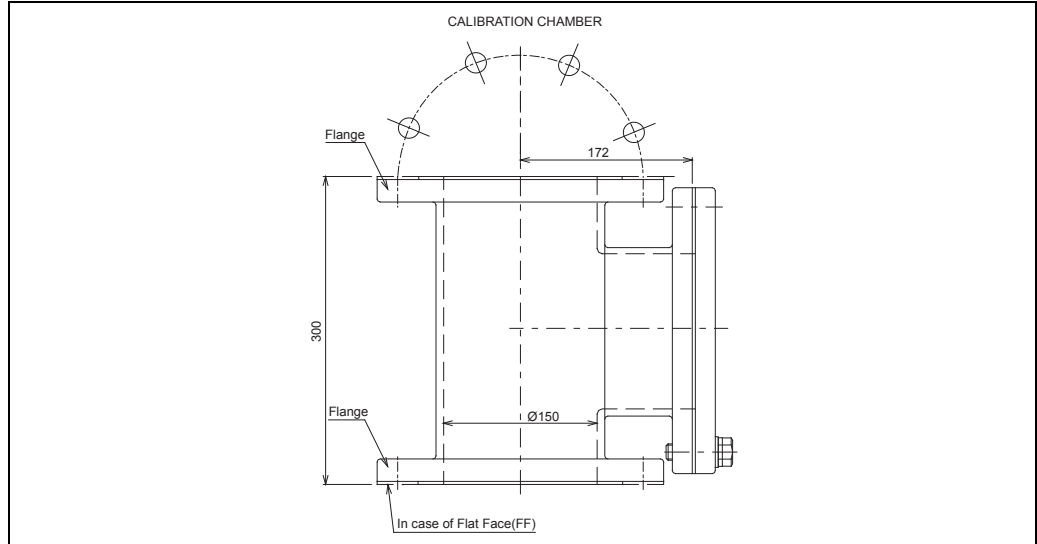

10.2 Power+Control Switch

NHS8

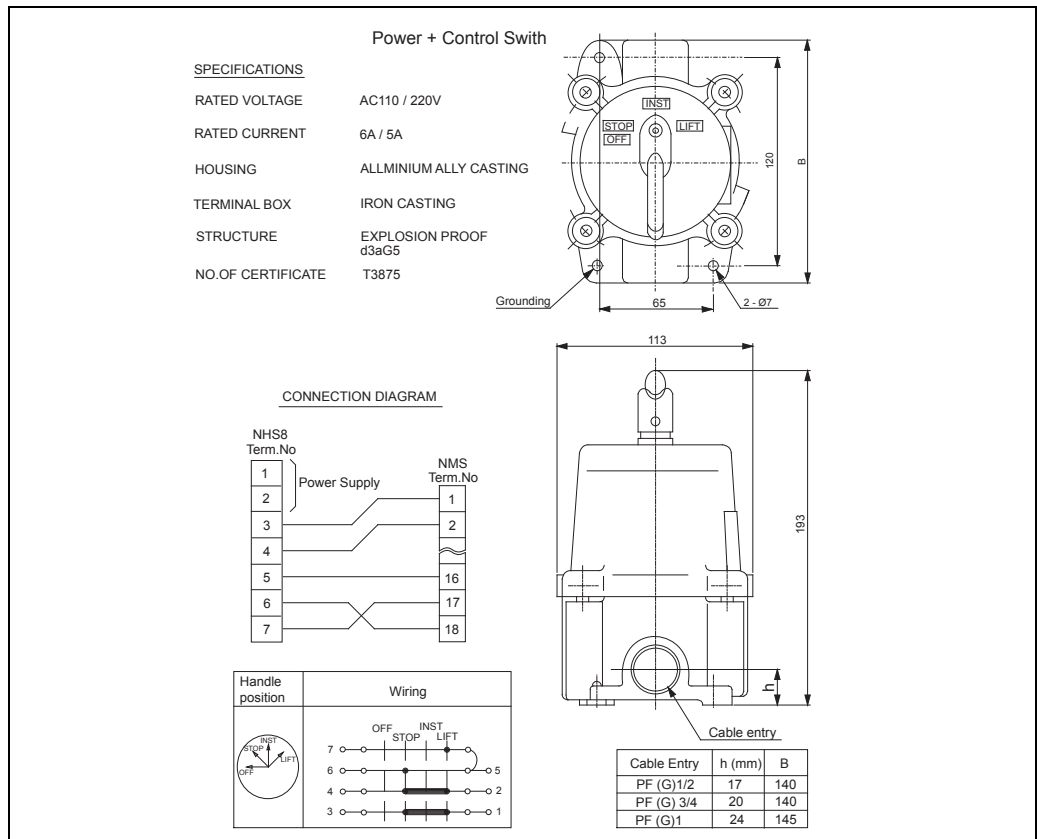

10.3 Ball valve NHV4A

NHV4A: Standard ball valve with ANSI flanges.

NHV4J: Standard ball valve with JIS flanges.

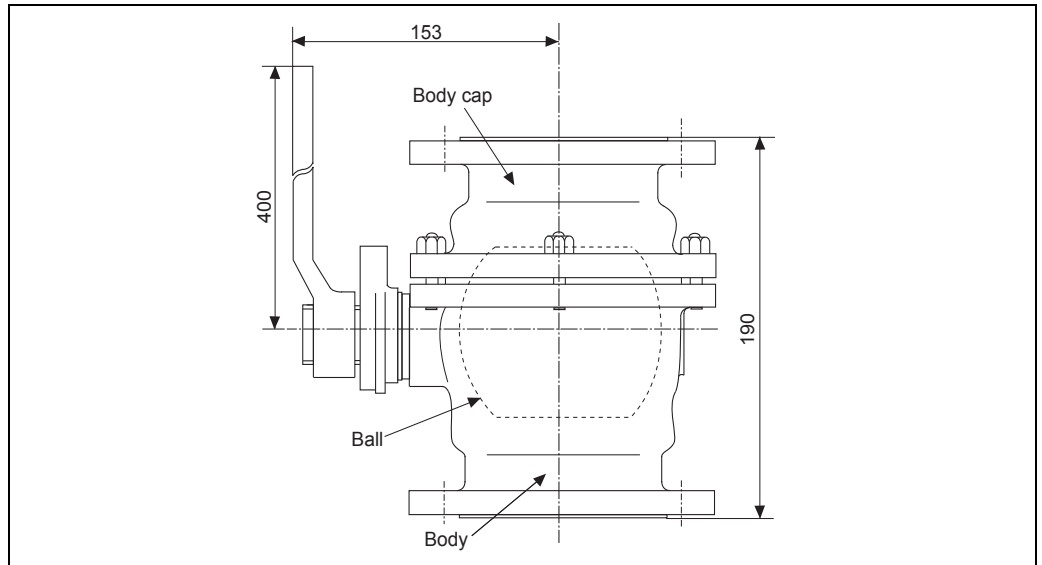

10.4 Reducing Flange NHF4

NHF4

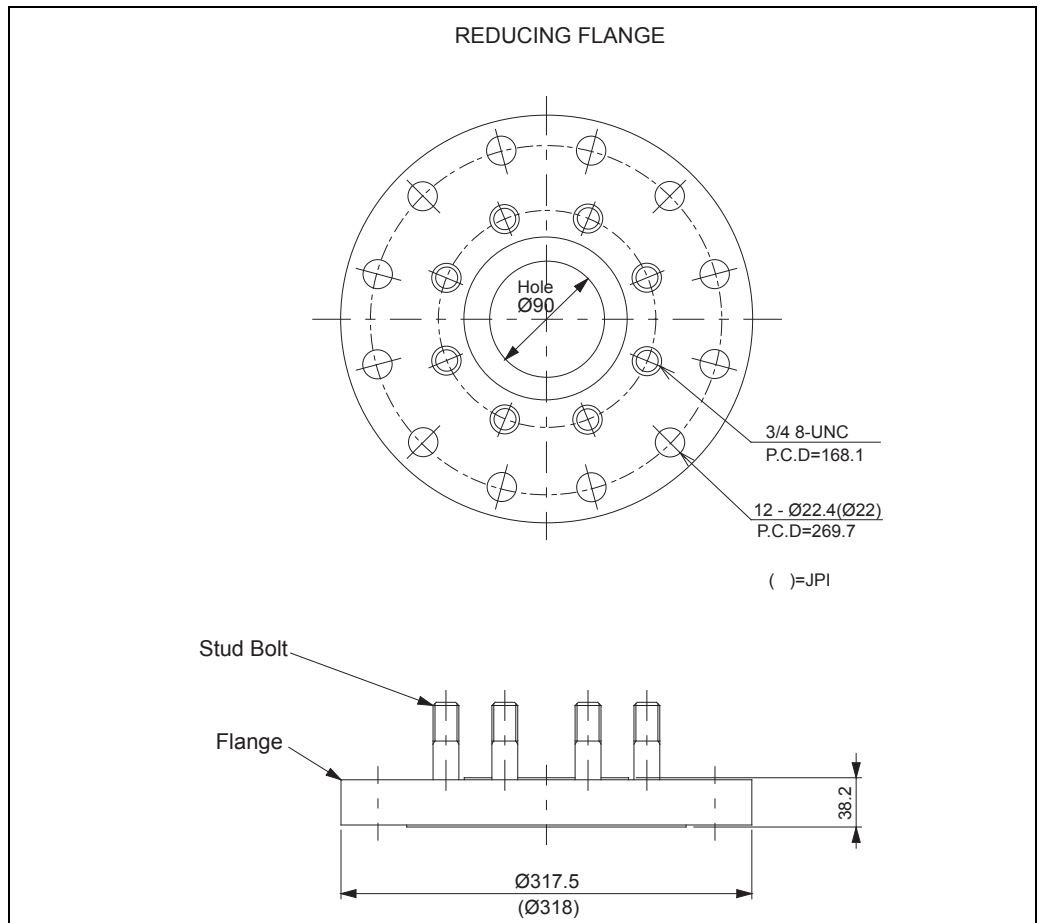

11 Technical data

11.1 Technical Specifications

Measuring range	0 to 10/16/28 /36/(100 m available on request)
Density limits	0.5 to 2.0 g/ml
Self-diagnostic function	Measuring wire tension, level data input, and communications, status, computer diagnostic, etc.
Liquid surface following speed	0 to 2,500 mm/min.
Display	Backlight LCD (indicating level and temperature at the same time) (Japanese, English, Chinese selectable)
Operation	Via touch control (touch-sensitive keys) or external contact input
Calibration	Automated (changes in displacer weight and wire build up automatically compensated)
Compensation	Compensation for tank distortion
Parts maintenance and management information	Load ratio calculated from the quantity of operation and operating ratio.
Notepad function	Maintenance notepad
Level Accuracy (50 mm displacer)	Liquid level: ± 0.7 mm for L=10 m, $D_r=1\text{g/cm}^3$ Interface level: ± 2.7 mm for L=10 m, $D_1 - D_2 \geq 0.2\text{g/cm}^3$
Density Accuracy	0.005 g/ml
Tank bottom	± 2.1 mm
Power requirements	High Voltage type: 85-264 VAC, 50/60 Hz, Low Voltage type: 20-62 VDC / 20-55V, 50/60 Hz
Consumption	Max. 50VA, 50W
Lightning arrestor	Standard equipment
Temperature limits	-20 to +60 °C (environmental temperature) -40 to +60 °C (ATEX Ex d)
Weight	NMS 531/534; 12kg NMS 532/5/6/7; 27kg
Protection class	IP 67 / NEMA 4X TIIIS Ex d IIB T4 GENELEC EEx d IIB T6 PTB Zone 0 EEx d IIB T6 (only for SS drum chamber) FM XP Class 1, Div. 1, Gr. CD CSA Class 1, Div. 1, Gr. CD ATEX EEx d IIB T6 ATEX Zone 0 EEx d IIB T6 (only for SS drum chamber) ATEX EEx d [ia] IIB T6 ATEX Zone 0 EEx d [ia] IIB T6 (only for SS drum chamber) FM XP-AIS Class 1, Div.1, Gr. CD, FM: EEx d [ia] ATEX EEx d IIC T6 ATEX EEx d IIC T6, Zone 0 (only for SS drum chamber) ATEX EEx d IIB T6, -40 dec. ATEX EEx d IIB T6 Zone 0, -40 dec. (only for SS drum chamber)
Weight & Measures requirements approval	PTB (Germany), NMI (Netherlands)
Liquid leakage alarm requirements approval	TÜV Overspill protection (Germany)
Paint color	Body: blue (RAL5012); Covers: white (RAL7035)
Input/Output	see Ordering information

12 Matrix

12.1 Programming Matrix

GROUP MESSAGE	H		V		1		2		3		4		5		6		7		8		9	
	0	1	0	1	0.0 mm	0.0 mm	0.0 mm	0.0 mm	0.0 mm	0.0 mm	0.0 mm	0.0 mm	0.0 mm	0.0 mm	0.0 mm	0.0 mm	0.0 mm	0.0 mm	0.0 mm	0.0 mm	0.0 mm	0.0 mm
MEASURED VALUE 1	0	MEASURED LEVEL	0.0 mm	ULLAGE LEVEL	UPPER INTERF. LEV.	UPPER INTERF. LEV.	MIDD. INTERF. LEV.	BOTTOM LEVEL	0.0 mm	0.0 mm	0.0 mm	0.0 mm	0.0 mm	0.0 mm	0.0 mm	0.0 mm	0.0 mm	0.0 mm	0.0 mm	0.0 mm	0.0 mm	0.0 mm
MEASURED VALUE 2	1	LIQUID TEMP.	0.0°C	DEV(1)	DEV(2)	DEV(2)	GAS TEMPERATURE	WATER BOTTOM	0.0°C	0.0°C	0.0°C	0.0°C	0.0°C	0.0°C	0.0°C	0.0°C	0.0°C	0.0°C	0.0°C	0.0°C	0.0°C	0.0°C
OPERATION	2	STOP	STOP	OPERATING STATUS	UNBALANCED	UNBALANCED	BALANCING STATUS	LEVEL	LEVEL	LEVEL	LEVEL	LEVEL	LEVEL	LEVEL	LEVEL	LEVEL	LEVEL	LEVEL	LEVEL	LEVEL	LEVEL	LEVEL
MORE FUNCTION	3	CALIBRATION	MATRIX OF 0-8	CALIBRATION	CALENDER	CALENDER	98 627 8:21:00	NO ALARM	ALARM CONTACT 0	NO ALARM	NO ALARM	NO ALARM	NO ALARM	NO ALARM	NO ALARM	NO ALARM	NO ALARM	NO ALARM	NO ALARM	NO ALARM	NO ALARM	NO ALARM

Default Data
Display Text
Parameters,
unit, etc
Mode (Code)

When new NMS status is selected at GVH=272, new status codes are shown at matrix position GVH=021 as follows;

Code	Meaning	NMS Display	Code	Meaning	NMS Display	Code	Meaning	NMS Display
0	No definition	-	12	Release over tension	RELE. OVER TENS.	24	Not initialised	NO INITIALIZE
1	Displacer at reference	REFERENCE	13	Calibration activated	CAL. ACTIVE	25	Stopped at High Stop	UPPER STOP
2	Displacer hoisting up	UP	14	Seek level	LEVEL SEEKING	26	Stopped at Low Stop	LOWER STOP
3	Displacer going down	DOWN	15	Follow level	LEVEL FOLLOWING	27	Repeatability testing	REPEATABILITY
4	Displacer stop	STOP	16	Seek Upper Density	UPP. DEN. SEEKING	28	Seeking water level	WATER SEEKING
5	Level measurement, balanced	LEVEL	17	Seek Middle Density	MID. DEN. SEEKING	29	Water level, balanced	WATER LEVEL
6	Upp. 1/F level, balanced	UPPER INTERF. LEV.	18	Seek Density Bottom	BOT. DEN. SEEKING	30	Follow water level	WATER FOLLOWING
7	Midd. 1/F level, balanced	MIDD. INTERF. LEV.	19	Seek Upper 1/F level	UPP. INT. SEEKING	31	Over-/Under tension,	EMERGENCY ERROR
8	Bottom meas. balanced	BOTTOM LEVEL	20	Follow up. 1/F level	UPP. INT. FOLLOWING	32	Z-Phase, ADC error	MAINTENANCE
9	Upper Dens. finished	UPPER DENSITY	21	Seek Mid. 1/F level	MID. INT. SEEKING		Service Mode = ON,	[Modbus / HART only]
10	Middle Dens. finished	MIDDLE DENSITY	22	Follow Mid. 1/F level	MID. INT. FOLLOWING			
11	Bottom Dens. finished	DENSITY BOTTOM	23	Seek Bottom level	BOTTOM SEEKING			

Operating commands

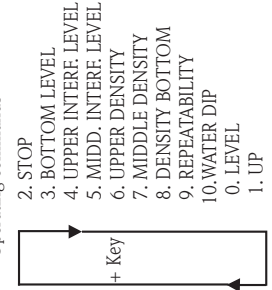

NMS5 Programming Matrix (dynamic Matrix, Calibration: G1)

GROUP MESSAGE	H		V										
			0	1	2	3	4	5	6	7	8	9	
LEVEL DATA	4	16000.0 mm TANK HEIGHT 0 - 99999.9 mm Set (50)	0.0 mm DIP POINT OFFSET 0 - 99999.9 mm Set (50)	10.0 mm DISPLAC. DRAFT 0 - 999.9 mm Set (50)	150 mm DISPL. RAISE DENS 0 - 300 mm Set (51)	150 mm DISPL. SUBM.DENS 0 - 1500 mm Set (51)	300.0 mm DEN. OPE LEVEL 0 - 99999.9 mm Set (51)	10 s DISPL. WAIT REP. 10 - 999 sec. Set (51)	10 s DISPL. WAIT REP. 10 - 999 sec. Set (51)	10 s DISPL. WAIT DIP 10 - 999 sec. Set (51)	ON PROSAFETY OFF Set (530)	99999 mm LEVEL BELOW 0 0 mm Select (51)	99999.0 mm SAFETY LEVEL 0 - 99999.0 mm Set (530)
	5	16000.0 mm SET LEVEL 0 - 99999.9 mm Set (50)	0.0 mm TANK CORRECT LEV 0 - 99999.9 mm Set (51)	0.000 mm/m TANK CORRE. COEF 0 - 59.999 mm/m Set (51)	OFF SAFE DENSITY ON IGNOR Select (51)	OFF SAFE DENSITY ON IGNOR Select (51)	0.0 mm SLOW HOIST 60 - 1800 mm Set (51)	10 mm DISPL. RAIS. REP. 10 - 99 mm Set (51)	10 s DISPL. WAIT REP. 10 - 999 sec. Set (51)	10 s DISPL. WAIT DIP 10 - 999 sec. Set (51)	OFF SERVICE MODE ON Set (530)	ON PROSAFETY OFF Set (530)	99999.0 mm SAFETY LEVEL 0 - 99999.0 mm Set (530)
ADJUSTMENT	6	16000.0 mm UPPER STOP 0 - 99999.9 mm Set (50)	0 mm LOWER STOP 0 - 99999.9 mm Set (50)	350 g OVER TENS. SET 0 - 999 g Set (51)	50 g UNDER TENS. SET 0 - 999 g Set (51)	60 mm SLOW HOIST 60 - 1800 mm Set (51)	10 mm DISPL. RAIS. REP. 10 - 99 mm Set (51)	10 s DISPL. WAIT REP. 10 - 999 sec. Set (51)	10 s DISPL. WAIT DIP 10 - 999 sec. Set (51)	10 s DISPL. WAIT REP. 10 - 999 sec. Set (51)	10 s DISPL. WAIT REP. 10 - 999 sec. Set (51)	10 s DISPL. WAIT REP. 10 - 999 sec. Set (51)	10 s DISPL. WAIT REP. 10 - 999 sec. Set (51)
	7	NONE CALIBR. AUTO/MAN MANUAL AUTOMATIC Set (51)	99123123 START TIME 0 - 999999 Set (51)	0 hour INTERVAL TIME 0 - 9999 hour Set (51)	OFF AUTO COMPENSAT. ON Set (51)	0.0 mm ZERO CORRECTION 0 - 99999.9 Set (51)	0.0 mm COMPENS. LIMIT 0 - 99999.9 Set (51)	0.0 mm COMPENS. LIMIT 0 - 99.9 Set (51)	0.0 mm COMPENS. LIMIT 0 - 99.9 Set (51)	0.0 mm COMPENS. LIMIT 0 - 99.9 Set (51)	0.0 mm COMPENS. LIMIT 0 - 99.9 Set (51)	0.0 mm COMPENS. LIMIT 0 - 99.9 Set (51)	0.0 mm COMPENS. LIMIT 0 - 99.9 Set (51)
AUTO CALIB. DISPL	8	NONE CALIBR. AUTO/MAN 0 - 2 Set (51)	99123123 START TIME 0 - 999999 Set (51)	0 hour INTERVAL TIME 0 - 9999 hour Set (51)	OFF AUTO COMPENSAT. ON Set (51)	0.0 g DEVIATION 0 - 999.9 Set (51)	0.0 g DEVIATION 0 - 999.9 Set (51)	0.0 g DEVIATION 0 - 999.9 Set (51)	0.0 g DEVIATION 0 - 999.9 Set (51)	0.0 g DEVIATION 0 - 999.9 Set (51)	0.0 g DEVIATION 0 - 999.9 Set (51)	0.0 g DEVIATION 0 - 999.9 Set (51)	0.0 g DEVIATION 0 - 999.9 Set (51)
	9	MEASURED LEVEL SELECT DISP. MODE ULLAGE LEVEL MEASURED LEVEL Set (51)	ENGLISH LANGUAGE JAPANESE CHINESE Set (51)	■■■■■■■■■■ LCD CONTRAST 0 - 15 set (51)	1 YEAR SETTING 0 - 99 Current year Set (51)	2 MONTH SETTING 0 - 12 Current month Set (51)	15 DAY SETTING 0 - 31 Current day Set (51)	13 HOUR SETTING 0 - 23 Current hour Set (51)	59 MINUTE SETTING 0 - 59 Current minute Set (51)	[.] SELECT DECIMAL , Set (51)	OFF LCD CHECK ON Set (51)	OFF LCD CHECK ON Set (51)	OFF LCD CHECK ON Set (51)

NMS 53x Programming Matrix (Dynamic Matrix, Device Data : G2)

GROUP MESSAGE	H		V		0	1	2	3	4	5	6	7	8	9
CONTACT OUTPUT	4		1		SELECT. RELAY Max 4 Select (50)	NONE ASSIGN RELAY LEVEL, LIQUID TEMP., CAUTION, WARNING, EMERGENCY ERROR Select (50)	HIGH RELAY FUNCTION LOW Select (50)	0 mm SWITCHING POINT Max. 99999 mm Select (50)	0 mm HYSTERISIS Max. 9999 mm Select (50)	NORMAL OPENED RELAY ON ALARM NORMAL CLOSED Set (50)	0 s ON DELAY TIME Max. 999 s Set (50)	0 s OFF DELAY TIME Max. 999 s Set (50)		
ANALOG OUT. ADJUST	5				NONE ASSIGN OUTPUT 1 LEVEL LIQUID TEMP. Select (51)	0 mm ADJUST 4mA FOR LIQUID TEMP. Set (51)	0 mm ADJUST 20mA FOR LIQUID TEMP. Set (51)	NONE ASSIGN OUTPUT 2 LEVEL LIQUID TEMP. Set (51)	0 mm ADJUST 4mA FOR LIQUID TEMP. Set (51)	0 mm ADJUST 20mA FOR LIQUID TEMP. Set (51)	OFF DEVICE AT ALARM HOLD CURNT. OUT MAX MIN Set (51)			
PARTS DATA	6		1		PARTS NUMBER Max 10 Select (51)	NONE PARTS TYPE POWER UNIT, DISPLAY MOTOR, WIRE, BEARINGS, SHAFT Select (51)	OPERATION HOUR MAINTEN. FACTOR DRUM REVOLT. Select (51)	1 hour MAINTEN. VALUE 999999 hour Set (51)	0 hour OPERATION TIME 999999 hour set (51)	POWER UNIT PH 0 0 0 Display (51)	NONE REPLACED PARTS Set (51)	NONE MH 0 0 0		
INPUT SIGNAL	7				NONE OPE. CONTACT ACTIVATED Select (51)	OFF CUSTODY TRANSFER Select (51)	DISABLED NEW NMS STATUS ENABLED Select (51)			4.27 SOFT WARE VERSION Display	6.00 HARD WARE VERSION Display		1.00 g/ml OPE. DENSITY 0 - 3.000 Set (51)	0 OPE. CONT. STATUS 2 - 256 Display (51)
COMMUNICATION	8				HIGH LEVEL ALARM 1 LOW NONE Select (51)	0.0 mm SET LEVEL ALARM 1 Max. 99999.9 mm Set (51)	HIGH LEVEL ALARM 2 LOW NONE Select (51)	0.0 mm SET LEVEL ALARM 2 Max. 99999.9 mm Set (51)	0.0 mm HYSTERISYS Max. 99999.9 mm Set (51)	0 ADDRESS 0 - FF for MIC->FF fixed 1 - 247 Modbus Set (51)	WM550, M/S PROTOCOL BBB, MDP, V1, ENRAF, RACK BUS, HART Set (51)	F COMMUN. LINE ADJ. 0 - F Set (51)	0 MODBUS Config 0 - 14 Display (51)	0 Set (51)
STATUS	9				0 s STATUS1 DELAY to 99 s Set (51)	NONE SELECT CONTACT NORMAL OPENED NORMAL CLOSED (ALARM=OPEN) (ALARM=CLOSE) Select (51)	1 WM550 ALIM. SELECT 1 - 3 Select (51)	0 WM550 BSW. SELECT 0 - 1 Select (51)	0 WM550 DENS. SEL. 0 - 2 Select (51)	37 WM550 SW_ID_20xx 0 - 99 Set (51)			0 s BALANCE DELAY to 99 s Set (51)	

NMS5 Programming Matrix (Dynamic Matrix, Service: G3)

GROUP MESSAGE	H											
	V		0	1	2	3	4	5	6	7	8	9
MEAS. WIRE & DRUM	4	300.00 mm WIRE DRUM CIRC. 0 - 999.9 Set (51)	1.4g / 10m WIRE WEIGHT 0 - 999.9 Set (51)	255.0 g DISPLACER WEIGH 0 - 999.9 Set (51)	145.0 ml DISPLACER VOLUM 0 - 999.9 Set (51)	60 ml BALANCE VOLUME 0 - 999.9 Set (51)	1.0 ml VOLUME TOLERANCE 0 - 99.9 Set (51)		20 X 100 mS DELAY 0 - 99 Set (51)	0.00 mm/m DRUM CORRECTION 0 - 99.00 Set (51)	0 count DISPL. HUNT.COUNT 0 - 99 Set (51)	
GAUGE DATA	5			OFF NON HYSTER. MODE ON	OFF HI.ACCURACY MODE ON	0 s HI. ACCR. OPE. TIME 0 - 600 Set (51)	50 mm HI. ACC. DISP. UP 0 - 300 Set (51)	999 °C GAUGE TEMP. Display (51)				
SYSTEM DATA	6	LOCAL : MASTER SENSOR DATA REMOVED COM. ON SOFTWARE = 04.24 HARDWARE = TGB 04 GEAR 1:36 NOT OVERSPILL	OFF CONNECTION NRE CONTACT 1 CONTACT 2 Set (51)	OFF CONNECTION NMIT SPOT TEMP. AVERAGE TEMP. Set (51)	OFF CONNECTION NMT Set (51)	OFF Set (51)	OFF Set (51)	OFF Set (51)	IF_LEVEL SELECT UP_IF_LEVEL WATER BOTTOM WATER BOTTOM.2 Set (51)	OFF SOFT RESET Set (51)		
SERVICE	7	0.0 g MEASURED WEIGHT Display	OFF RELE. OVER TENS ON Set (51)	OFF DRUM SETTING ON Set (51)	OFF WEIGHT CALIBR. ON Set (51)					70 mm DISPL. REFERENCE Set (51)	0.0 g ZERO ADJ. WEIGHT Set (51)	
SENSOR VALUE	8	Sa=21000 ; A=21000 Sb=11000 ; B=11000 Display (51)										
SENSOR DATA	9					0 0 0.0 g WT. COUNT CALA Display (51)	0 0 0.0 g WT. COUNT CAL B Display (51)					

NMS5 Programming Matrix (Dynamic Matrix, Temperature : G4)

GROUP MESSAGE	V	H	0	1	2	3	4	5	6	7	8	9									
TEMPERATURE DATA	4	xx °C	LIQUID TEMP. Depending on a specification and measured value Display (51)	zz °C	GAS TEMPERATURE Depending on a specification and measured value Display (51)	aaaa.a mm	MEASURED LEVEL Depending on a specification and measured value Display (51)	VH00	LEV. DATA SELECT VH00 or VH08 Select (51)	0.0 mm	WATER BOTTOM Depending on a specification and measured value Display (51)	0.0 °C	REFERENCE ZERO Depending on a specification and measured value Display (51)	150.0 °C	REFERENCE 150 Depending on a specification and measured value Display (51)						
ELEMENT TEMP.	5	aa.a °C	TEMP. NO.1 Depending on a specification and measured value Display (51)	bb.b °C	TEMP. NO.2 Depending on a specification and measured value Display (51)	cc.c °C	TEMP. NO.3 Depending on a specification and measured value Display (51)	dd.d °C	TEMP. NO.4 Depending on a specification and measured value Display (51)	ee.e °C	TEMP. NO.5 Depending on a specification and measured value Display (51)	ff.f °C	TEMP. NO.6 Depending on a specification and measured value Display (51)	gg.g °C	TEMP. NO.7 Depending on a specification and measured value Display (51)	hh.h °C	TEMP. NO.8 Depending on a specification and measured value Display (51)	ii.i °C	TEMP. NO.9 Depending on a specification and measured value Display (51)	jj.j °C	TEMP. NO.10 Depending on a specification and measured value Display (51)
ELEMENT POSITION	6	xxx.x mm	ELEM. 1 POSITION Depending on a specification and measured value Display (51)	xxx.x mm	ELEM. 2 POSITION Depending on a specification and measured value Display (51)	xxx.x mm	ELEM. 3 POSITION Depending on a specification and measured value Display (51)	xxx.x mm	ELEM. 4 POSITION Depending on a specification and measured value Display (51)	xxx.x mm	ELEM. 5 POSITION Depending on a specification and measured value Display (51)	xxx.x mm	ELEM. 6 POSITION Depending on a specification and measured value Display (51)	xxx.x mm	ELEM. 7 POSITION Depending on a specification and measured value Display (51)	xxx.x mm	ELEM. 8 POSITION Depending on a specification and measured value Display (51)	xxx.x mm	ELEM. 9 POSITION Depending on a specification and measured value Display (51)	xxx.x mm	ELEM. 10 POSITION Depending on a specification and measured value Display (51)
NMT ADJUSTMENT	7	0	SELECT POINT 0 - 15 Selectable SELECT POINT + 1 = ELEMENT No. Set (51)	x.x °C	ZERO ADJUST	1.000	GAIN ADJUST	xx.x °C	ELEMENT TEMP. Current data Display (51)	xxx.x mm	ELEMENT POSITION Current data Display (51)	2	AVERAGE TIME	530	ACCESS CODE						
SET DATA NMT	8	0	DIAGNOSTIC	°C	TEMPERATURE UNIT	xx	TOTAL NO. ELEMENTS 2 - 16 Set (51)	5	PREAMBLE NUMBER 1 - 16 Set (51)	mm	LENGTH UNIT Display (51)	500.0 mm	BOTTOM POINT 0.0 mm to 500.0 mm variable Set (51)	200.0 mm	ELEMENT INTERVAL	-49.5 °C	TEMP. ELEM. SHORT	359.0 °C	TEMP. ELEM. OPEN		
DEVICE DATA NMT	9	xxxxxx	INSTRUMENT CODE	LAST DIAGNOSTIC	OUTPUT AT ERROR	OFF	CUSTODY TRANSFER ON Set (51)	17	MANUFACTURE ID Display (51)	2	POLLING ADDRESS Display (51)	6	SOFTWARE VERSION	2	HARDWARE VERSION	DEVELOPMENT CODE	DEVICE TYPE CODE				

NMS5 Programming Matrix (Dynamic Matrix, HART DEVICE (1) : G5)

GROUP MESSAGE	H		0	1	2	3	4	5	6	7	8	9
	V											
MEASURED VALUE	4		PV DATA Display	SV DATA Display								OFF HART DEVICE (1) ON LIQUID TEMP. GAS TEMPERATURE Select (51)
P.V. SETTING	5		P. V. RANGE UNIT Set (51)	P. V. UPPER RANGE Set (51)	P. V. LOWER RANGE Set (51)	DAMP VALUE Set (51)						
SENSOR SPECIFIC	6		SENSOR SERIAL NO Display	UPPER SENSOR LMT Display	LOWER SENSOR LMT Display							
ALARM	7											
SELF DIAGNOSTIC	8		ERROR CODE (1) Display	ERROR CODE (2) Display	ERROR CODE (3) Display	ERROR CODE (4) Display	ERROR CODE (5) Display					
DEVICE DATA	9			POLLING ADDRESS (FIXED ADDRESS) Display	MANUFACTURE ID Display	DEVICE TYPE CODE Display	PREAMBLES Set(51)	SW VERSION Display	HW VERSION Display	DEVICE ID Display		

NMS5 Programming Matrix (Dynamic Matrix, HART DEVICE (2) : G6)

GROUP MESSAGE	H/V		0	1	2	3	4	5	6	7	8	9
MEASURED VALUE	4		PV DATA Display	SV DATA Display								OFF HART DEVICE (2) ON LIQUID TEMP. GAS TEMPERATURE Select (51)
P.V. SETTING	5		P. V. RANGE UNIT Set (51)	P. V. UPPER RANGE Set (51)	P. V. LOWER RANGE Set (51)	DAMP VALUE Set (51)						
SENSOR SPECIFIC	6		SENSOR SERIAL NO Display	UPPER SENSOR LMT Display	LOWER SENSOR LMT Display							
ALARM	7											
SELF DIAGNOSTIC	8		ERROR CODE (1) Display	ERROR CODE (2) Display	ERROR CODE (3) Display	ERROR CODE (4) Display	ERROR CODE (5) Display					
DEVICE DATA	9			5 POLLING ADDRESS (FIXED ADDRESS) Display	MANUFACTURE ID Display	DEVICE TYPE CODE Display	PREAMBLES Set(51)	SW VERSION Display	HW VERSION Display	DEVICE ID Display		

NMS5 Programming Matrix (Dynamic Matrix, ADJ. SENSOR : G7)

GROUP MESSAGE	H/V		0	1	2	3	4	5	6	7	8	9
	ADJ. SENSOR	4										
HART ERROR RATE	5											
UNIT	6		mm m inch cm ft Select (51)	°C TEMP. UNIT (HOST) °F °R °K Select (51)	g/mL DEN. UNIT (HOST) Kg/m ³ , lb/gal, SGL, Kg/gal, lb/m ³ , st/y ³ Select (51)			mm LEV. UNIT m inch cm ft Select (51)	°C TEMP. UNIT °F °R °K Select (51)	g/mL DEN. UNIT Kg/m ³ , lb/gal, SGL, Kg/gal, lb/m ³ , st/y Select (51)		
HART LINE	7		TERMINAL PORT B NMT TERMINAL PORT A Select (777)	TERMINAL PORT B HART DEVICE (1) TERMINAL PORT A Select (777)	TERMINAL PORT B HART DEVICE (2) TERMINAL PORT A Select (777)							
INTERFACE ADJUST	8		0.3 mL VOL. TOL. FOR I/F 0 - 99.9 mL Set (51)	150 BRAKE RATE 0 - 255 Set (51)	15 BALANCE COUNT 0 - 255 Set (51)	0.0 mm IF 1 OFFSET 0 - 9999.9 mm Set (51)	0.0 mm IF 2 OFFSET 0 - 9999.9 mm Set (51)					
LEVEL CORRECTION	9											

NMS5 Programming Matrix (Dynamic Matrix, Tank Profile : G8)

GROUP MESSAGE	H V	0	1	2	3	4	5	6	7	8	9
PROFILE OPE.	4	O : SPOT 0 : spot 1 : tank profile 2 : I/F profile 3 : MANU/I/F profile Display/Set (51)	2 OPE. POINT 2-16 Set (51)		0 I/F MANU. LEVEL 0 - 99999.9 mm Set (51)	2.0 mm BAL. LEVEL 1.0 - 99.9 mm Set (51)	1 min UP WAIT TIME 1- 31 min Set (51)	1 min LIQ. WAIT TIME 1- 31 min Set (51)	1 min OPE. WAIT TIME 1- 31 min Set (51)		
STATUS/DATA	5	0 OPE. STATUS 0 - 6 Display	0 LEVEL.CONDITION 0 - 4 Display	DDHHMM OPE. TIME 000000 - 312359		0.000 g/ml AVERAGE DENSITY 0.000 - 9.999 g/mL	0.0 °C AVERAGE TEMP. 0 - 369.5 °C				
DENSITY 1 - 10	6	0.000 g/ml NO. 1 DENSITY 0.000 - 9.999 g/ml Display	0.000 g/ml NO. 2 DENSITY 0.000 - 9.999 g/ml Display	0.000 g/ml NO. 3 DENSITY 0.000 - 9.999 g/ml Display	0.000 g/ml NO. 4 DENSITY 0.000 - 9.999 g/ml Display	0.000 g/ml NO. 5 DENSITY 0.000 - 9.999 g/ml Display	0.000 g/ml NO. 6 DENSITY 0.000 - 9.999 g/ml Display	0.000 g/ml NO. 7 DENSITY 0.000 - 9.999 g/ml Display	0.000 g/ml NO. 8 DENSITY 0.000 - 9.999 g/ml Display	0.000 g/ml NO. 9 DENSITY 0.000 - 9.999 g/ml Display	0.000 g/ml NO. 10 DENSITY 0.000 - 9.999 g/ml Display
DENSITY 11 - 16	7	0.000 g/ml NO. 11 DENSITY 0.000 - 9.999 g/ml Display	0.000 g/ml NO. 12 DENSITY 0.000 - 9.999 g/ml Display	0.000 g/ml NO. 13 DENSITY 0.000 - 9.999 g/ml Display	0.000 g/ml NO. 14 DENSITY 0.000 - 9.999 g/ml Display	0.000 g/ml NO. 15 DENSITY 0.000 - 9.999 g/ml Display	0.000 g/ml NO. 16 DENSITY 0.000 - 9.999 g/ml Display				
POSITION 1 - 10	8	0 mm NO.1 POSITION 0 - 99999.9 mm Display	0 mm NO.2 POSITION 0 - 99999.9 mm Display	0 mm NO.3 POSITION 0 - 99999.9 mm Display	0 mm NO.4 POSITION 0 - 99999.9 mm Display	0 mm NO.5 POSITION 0 - 99999.9 mm Display	0 mm NO.6 POSITION 0 - 99999.9 mm Display	0 mm NO.7 POSITION 0 - 99999.9 mm Display	0 mm NO.8 POSITION 0 - 99999.9 mm Display	0 mm NO.9 POSITION 0 - 99999.9 mm Display	0 mm NO.10 POSITION 0 - 99999.9 mm Display
POSITION 11 - 16	9	0 mm NO.11 POSITION 0 - 99999.9 mm Display	0 mm NO.12 POSITION 0 - 99999.9 mm Display	0 mm NO.13 POSITION 0 - 99999.9 mm Display	0 mm NO.14 POSITION 0 - 99999.9 mm Display	0 mm NO.15 POSITION 0 - 99999.9 mm Display	0 mm NO.1 POSITION 0 - 99999.9 mm Display				

NMS5 Programming Matrix (Dynamic Matrix, Interface Profile : G9)

GROUP MESSAGE	H		0	1	2	3	4	5	6	7	8	9
	V											
	4											
STATUS/DATA	5	0	0	0	DDHMM	0 mm	0.000 g/ml	0.0 °C				
		0	0	0	0	0	0	0	0	0	0	0
		0	0	0	0	0	0	0	0	0	0	0
DENSITY 1 - 10	6	0.000 g/ml	0.000 g/ml	0.000 g/ml	0.000 g/ml	0.000 g/ml	0.000 g/ml	0.000 g/ml	0.000 g/ml	0.000 g/ml	0.000 g/ml	0.000 g/ml
		NO. 1 DENSITY	NO. 2 DENSITY	NO. 3 DENSITY	NO. 4 DENSITY	NO. 5 DENSITY	NO. 6 DENSITY	NO. 7 DENSITY	NO. 8 DENSITY	NO. 9 DENSITY	NO. 10 DENSITY	
		0.000 - 9.999 g/ml	0.000 - 9.999 g/ml	0.000 - 9.999 g/ml	0.000 - 9.999 g/ml	0.000 - 9.999 g/ml	0.000 - 9.999 g/ml	0.000 - 9.999 g/ml	0.000 - 9.999 g/ml	0.000 - 9.999 g/ml	0.000 - 9.999 g/ml	
		Display	Display	Display	Display	Display	Display	Display	Display	Display	Display	Display
DENSITY 11 - 16	7	0.000 g/ml	0.000 g/ml	0.000 g/ml	0.000 g/ml	0.000 g/ml	0.000 g/ml	0.000 g/ml				
		NO. 11 DENSITY	NO. 12 DENSITY	NO. 13 DENSITY	NO. 14 DENSITY	NO. 15 DENSITY	NO. 16 DENSITY					
		0.000 - 9.999 g/ml	0.000 - 9.999 g/ml	0.000 - 9.999 g/ml	0.000 - 9.999 g/ml	0.000 - 9.999 g/ml	0.000 - 9.999 g/ml					
		Display	Display	Display	Display	Display	Display					
POSITION 1 - 10	8	0 mm	0 mm	0 mm	0 mm	0 mm	0 mm	0 mm	0 mm	0 mm	0 mm	0 mm
		NO. 1 POSITION	NO. 2 POSITION	NO. 3 POSITION	NO. 4 POSITION	NO. 5 POSITION	NO. 6 POSITION	NO. 7 POSITION	NO. 8 POSITION	NO. 9 POSITION	NO. 10 POSITION	
		0 - 99999.9 mm	0 - 99999.9 mm	0 - 99999.9 mm	0 - 99999.9 mm	0 - 99999.9 mm	0 - 99999.9 mm	0 - 99999.9 mm	0 - 99999.9 mm	0 - 99999.9 mm	0 - 99999.9 mm	
		Display	Display	Display	Display	Display	Display	Display	Display	Display	Display	Display
POSITION 11 - 16	9	0 mm	0 mm	0 mm	0 mm	0 mm	0 mm	0 mm				
		NO. 11 POSITION	NO. 12 POSITION	NO. 13 POSITION	NO. 14 POSITION	NO. 15 POSITION	NO. 16 POSITION					
		0 - 99999.9 mm	0 - 99999.9 mm	0 - 99999.9 mm	0 - 99999.9 mm	0 - 99999.9 mm	0 - 99999.9 mm					
		Display	Display	Display	Display	Display	Display					

12.2 Description of the Programming Matrix

Matrix group	Function group	Item	Access code	Short description	Default value	Set Select Display	Possible settings, selection, or display	Index No, GVH
STATIC MATRIX (This word is not shown)	MEASURED VALUE 1	MEASURED LEVEL	0	Displays displacer position in relation to Ullage (Outage) or Innage as Defined by GVH190 Display Mode.	16000.0 mm	Display	0.0 ... 99999.9 mm	000
		ULLAGE LEVEL	0	Displays difference between current displacer position and Tank Height.	0.0 mm	Display	0.0 ... 99999.9 mm	001
		UPPER INTERF. LEV	0	Displays last recorded Upper Interface level measurement	0.0 mm	Display	0.0 ... 99999.9 mm	002
		MIDD. INTERF. LEV	0	Displays last recorded Middle Interface level measurement	0.0 mm	Display	0.0 ... 99999.9 mm	003
		BOTTOM LEVEL	0	Displays last recorded Bottom level measurement Refer to GVH004	0.0 mm	Display	0.0 ... 99999.9 mm	004
		UPPER DENSITY	51	Displays last recorded Upper Density measurement OR manual setting.	1.000 g/ml	Display/ Set	0.000...3.000 g/ml	005
		MIDDLE DENSITY	51	Displays last recorded Middle Density measurement OR manual setting.	1.000 g/ml	Display/ Set	0.000...3.000 g/ml	006
		DENSITY BOTTOM	51	Displays last recorded Density Bottom measurement OR manual setting.	1.000 g/ml	Display/ Set	0.000...3.000 g/ml	007
		LEVEL DATA	0	Displays last recorded Measured Level measurement according to Balance Status.		Display	0.000...3.000 g/ml	008
		STATUS 1	0	Switches the Contact Relay Input Status 1 Output Function on or off, especially for Oil Leak Detector Input. When input relay signal is ON, signal is output as Status 1 Alarm, and recorded in G0V3H7		Display	OFF / ON	009

Matrix group	Function group	Item	Access code	Short description	Default value	Set Select Display	Possible settings, selection, or display	Index No, GVH	
STATIC MATRIX (This word is not shown)	MEASURED VALUE 2	LQUID TEMP.	0	Displays Liquid Temperature data reflected from G4V4H0 (NMT) or from G5V4H0 (HART Dev 1) if G5V4H9 = "Liquid Temperature"	0.0 °C	Display	-49.9 ... 249.9 °C	010	
		DEV(1)	0	Displays Primary Variable data reflected from G5V4H0 (HART Dev 1) when G5V4H0 = ON, Liquid Temperature or Gas Temperature. Liquid Temperature data is also copied to G0V1H0. Gas Temperature data is also copied G0V1H0 unless G6V4H9 = Gas temperature		Display	0.0 ... 99999.9 mm	011	
		DEV(2)		Displays Primary Variable data reflected from G6V4H0 (HART Dev 2) when G6V4H9 = ON or Gas Temperature. Gas temperature data is also copied to G0V1H3		Display	0.0 ... 99999.9 mm	012	
		GAS TEMPERATURE	0	Displays Gas Temperature data reflected from G4V4H1, or from G5V4H0 if G5V4H9= Gas Temperature, or from G6V4H0 if G6V4H9 = Gas Temperature	0.0 °C	Display	-49.9 ... 249.9 °C	013	
		WATER BOTTOM	0	Displays water interface level data received from NMT 539 Prothermo WB device.	0.0 mm	Display		014	
		ZERO POINT	0	Displays Zero Point for Commuwin II bar graph	0 mm	Display	0.0 ... 99999.9 mm	017	
		SPAN	0	Displays Span for Commuwin II bar graph	16000.0 mm	Display	0.0 ... 99999.9 mm	018	
		LENGTH UNIT	0	Displays unit of length (selected at G7V6H0) for Commuwin II bar graph		Display	mm		019

Matrix group	Function group	Item	Access code	Short description	Default value	Set Select Display	Possible settings, selection, or display	Index No, GVH
STATIC MATRIX (This word is not shown)	OPERATION	OPERATION (from optical key)	50	Select operation for movement of displacer	STOP	Select	Refer to G0 Static Matrix, Operation commands.	020
		OPERATING STATUS	0	Displacer operation mode, or position status of Proservo	SPOT	Display	REFERENCE UP DOWN STOP LEVEL UPPER. INTERF. LEV. MIDD. INTERF. LEV. BOTTOM LEVEL UPPER DENSITY MIDDLE DENSITY DENSITY BOTTOM RELE. OVER TENS. CAL. ACTIVE LEVEL SEEKING LEVEL FOLLOWING UPP. DEN. SEEKING MID. DEN. SEEKING BOT. DEN. SEEKING UPP. INT. SEEKING UPP. INT. FOLLOWING MID. INT. SEEKING MID. INT. FOLLOWING BOTTOM SEEKING NO INITIALIZE UPPER STOP LOWER STOP REPEATABILITY WATER SEEKING WATER LEVEL WATER FOLLOWING EMERGENCY ERROR MAINTENANCE	021

Matrix group	Function group	Item	Access code	Short description	Default value	Set Select Display	Possible settings, selection, or display	Index No, GVH	
STATIC MATRIX (This word is not shown)	OPERATION	BALANCE STATUS	0	Displays balance status of displacer	UNBALANCED	Display	BALANCED UNBALANCED	022	
		OPERAT. BY NRF	0	Displays operation status of NRF. If no NRF connected, display will show asterisks *****.	LEVEL	Display	LEVEL UP STOP BOTTOM LEVEL MIDD. INTERF. LEVEL UPPER DENSITY MIDDLE DENSITY DENSITY BOTTOM REPEATABILITY WATER DIP	024	
			OPERAT. BY HOST	0	Displays operation status of Host CPU. If no HOST connected, display will show asterisks *****.	LEVEL	Display	LEVEL UP STOP BOTTOM LEVEL MIDD. INTERF. LEVEL UPPER DENSITY MIDDLE DENSITY DENSITY BOTTOM REPEATABILITY WATER DIP	025
			DEVICE ID	0	Displays the Device ID of NMS5/7 Proservo	0	Display		028
			SOFTWARE VERSION	0	Displays the software version of NMS5/7 Proservo	428	Display		029

Matrix group	Function group	Item	Access code	Short description	Default value	Set Select Display	Possible settings, selection, or display	Index No, GVH
STATIC MATRIX (This word is not shown)	MORE FUNCTION	MATRIX OF	0	Use (+) and (-) keys, scroll through 9 Dynamic Matrix Group selections. Press "E" key to select one for access to more data.	CALIBRATION	Select	CALIBRATION DEVICE DATA SERVICE TEMPERATURE HART DEVICE (1) HART DEVICE (2) ADJ. SENSOR	030
		(Calendar)	0	Displays date, time as yymmdd __hh:mm:ss. Not transferred by Rackbus.	Japanese local time	Display	e.g. 5 410 19:10:41 Year Month Day HH:MM:SS	033
		ALARM CONTACT	0	Display alarm message depending on current status.	NO ALARM	Display	Alarm message	034
		(Alarm History)	0	Use (+) and (-) keys, scroll through history of alarms. Up to 99 alarms recorded, then oldest alarm is overwritten by new data.	NO ALARM	Display	Alarm history	035
		DIAGNOSTIC CO	0	Displays current self-diagnostic code	NO ERROR	Display	Error message	036
		(Error History)	0	Use (+) and (-) keys, scroll through history of errors, in format yymmdd hhmm °° ##. Up to 99 alarms recorded, then oldest alarm is overwritten by new data.	MPI: START ACT	Display	Error history	037
		RESET ALM. DIAGNO	0	Reset Error History by setting = ON.	OFF	Display		038
		ACCESS CODE	0	Set access code to view and change to matrix data. Higher access codes (except 777) give greater editing privileges. 50: Operator, 51: technician, 777: required to select EEx i HART line,	0	Set	0, 50, 51, 777	039

Matrix group	Function group	Item	Access code	Short description	Default value	Set Select Display	Possible settings, selection, or display	Index No, GVH																						
CALIBRATION	LEVEL DATA	TANK HEIGHT	50	Elevation level of manual dipping reference.	16000.0 mm	Set	0 - 99999.9 mm	140																						
		DIP POINT OFFSET	50	Difference between Tank Height and Reference Position of Proservo NMS5/7. This data is automatically adjusted by Proservo software when Set Level procedure is performed.	0.0 mm	Set	0 - 99999.9 mm	141																						
		DISPLAC. DRAFT	50	Set the draft of displacer. This value is used to calculate GOV0H4 Bottom Level measurement. Typical Displacer Draft settings <table border="1" style="width: 100%; border-collapse: collapse;"> <tr> <td>Diameter</td> <td>30 mm</td> <td>40 mm</td> <td>50 mm</td> <td>50 mm</td> <td>70 mm</td> <td>110 mm</td> <td>110 mm</td> </tr> <tr> <td>Specification</td> <td>Special</td> <td>Special</td> <td>Std</td> <td>Conical</td> <td>NMI</td> <td>PTB, Level</td> <td>PTB, I/F</td> </tr> <tr> <td>Draft</td> <td>Varies</td> <td>Varies</td> <td>45 mm</td> <td>35 mm</td> <td>14 mm</td> <td>8 mm</td> <td>13 mm</td> </tr> </table>	Diameter	30 mm	40 mm	50 mm	50 mm	70 mm	110 mm	110 mm	Specification	Special	Special	Std	Conical	NMI	PTB, Level	PTB, I/F	Draft	Varies	Varies	45 mm	35 mm	14 mm	8 mm	13 mm	10.0 mm	Set
Diameter	30 mm	40 mm	50 mm	50 mm	70 mm	110 mm	110 mm																							
Specification	Special	Special	Std	Conical	NMI	PTB, Level	PTB, I/F																							
Draft	Varies	Varies	45 mm	35 mm	14 mm	8 mm	13 mm																							
		DISPL. RAISE DENS	51	Set distance for displacer to rise above level position during Density operations. Observe the rule: G1V4H3+ G1V4H4 = 300 n, where = integer	150 mm	Set	0 - 300 mm	143																						
		DISPL. SUBM. DENS	51	Set distance for displacer to sink below level position during Density operations. Observe the rule: G1V4H3+ G1V4H4 = 300 n, where = integer	150 mm	Set	0 - 1500 mm	144																						
		LEVEL BELOW 0	51	Select method for handling negative level data in V1 protocol communication. Select "99999 mm" to display negative level data backwards from 99999 mm. Select "0 mm" to display all negative level data as 0 mm.	99999 mm	Select	0 - 99999 mm	149																						

Matrix group	Function group	Item	Access code	Short description	Default value	Set Select Display	Possible settings, selection, or display	Index No, GVH
CALIBRATION	CALIBRATION	SET LEVEL	50	Calibrate NMS5/7 Proservo level display equal to manual dip level. With Operation = Level and NMS in balance status use +/- and E keys to adjust / set the data.	1 6000.0 mm	Set	0 - 99999,9 mm	150
		TANK CORRECT LEV.	51	Start level for tank roof compensation by level. This compensation is used in case of tank roof distortion due to hydrostatic pressure on tank wall.	0.0 mm	Set	0 - 99999,9 mm	152
		TANK CORRE. COEF.	51	Linear coefficient for tank roof compensation by level.	0.000 mm/m	Set	0 - 59,999 mm/m	153
		SAFE DENSITY	51	Select the desired resultant condition when density profile measurement fails due to displacer reaching the low-limit for density profile operation (set in G1V5H5). Selecting "ON" will result in STOP operation. Selecting "IGNOR" will result in "LEVEL" operation, displacer will return to liquid level. Selecting "OFF" will leave the displacer at the position where density profile measurement failed.	OFF	Set	OFF ON IGNOR	154
		DEN. OPE. LEVEL	51	Set the lower limit for displacer movement during density profile operation.	300 mm	Set	0 - 99999,9 mm	155
		SERVICE MODE	530	Deactivate Prosafty function during maintenance; level value not valid.	OFF	Set	ON / OFF	157
		PROSAFETY	530	Proactive safety function outputs maximum level value during specified error conditions	ON	Set	ON / OFF	158
		SAFETY LEVEL	530	Adjust maximum level output value, depending on receiver specification.	99999,0 / 65000,0	Set	0...99999,0	159

Matrix group	Function group	Item	Access code	Short description	Default value	Set Select Display	Possible settings, selection, or display	Index No, GVH
CALIBRATION	ADJUSTMENT	UPPER STOP	50	Set upper limit of displacer movement during normal operation.	16000 mm	Set	0 - 99999,9 mm	160
		LOWER STOP	50	Set lower limit of displacer movement during normal operation.	0 mm	Set	0 - 99999,9 mm	161
		OVER TENS. SET	51	Set this value such that if G3V7H0 Measured Weight of displacer equals or exceeds setting at G1V6H2, motor will freeze. Increase this parameter if necessary in high viscosity liquids. Caution!: Magnetic coupling disconnects above 800 grams tension.	350 g	Set	0 - 999 g	162
		UNDER TENS. SET	51	Set this value such that if G3V7H0 Measured Weight of displacer equals or is less than setting at G1V6H3, motor will freeze. Decrease this parameter if necessary in high viscosity liquids.	50 g	Set	0 - 999 g	163
		SLOW HOIST	51	Displacer will enter slow speed hoist according to this value, useful if displacer contacts with narrow valves.	60 mm	Set	60 - 1800 mm	164
		DISPL. RAIS. REP.	51	Set the distance to raise displacer above liquid surface during repeatability test.	10 mm	Set	10 - 99 mm	165
		DISPL. WAIT REP.	51	Set the waiting time after displacer rises above liquid surface during repeatability test.	10 s	Set	10 - 999 sec.	166
		DISPL. WAIT DIP.	51	Used for Water Level command. Set the waiting time between displacer balance status and return to Level.	10 s	Set	10 - 999 sec.	167

Matrix group	Function group	Item	Access code	Short description	Default value	Set Select Display	Possible settings, selection, or display	Index No, GVH
CALIBRATION	AUTO WIRE DISPL.	CALIBR. AUTO/MAN	51	Select method for measuring wire calibration. When activated, Proservo will hoist displacer into drum housing and check length of measuring wire. "Manual" setting is recommended to avoid unwanted calibration during tank loading etc.	NONE	Select	NONE MANUAL AUTOMATIC	170
		START TIME	51	Set start time for Auto Wire Calibration. Available when G1V7H0 = "Auto"	99123123	Set	0 - 999999	171
		INTERVAL TIME	51	Set interval time between automatic wire calibration operations. Available when G1V7H0 = "Auto"	0 hour	Set	0 - 9999 hour	172
		AUTO COMPENSAT.	51	Select to automatically compensate for measuring wire stretch or shrinkage detected at calibration	OFF	Select	OFF ON	173
		ZERO CORRECTION	51	Displays measuring wire length deviation detected at calibration.	0.0 mm	Set	0 - 99999.9	174
		COMPENS. LIMIT	51	Set upper limit for automatic compensation of measuring wire length. When G1V7H5 equals or exceeds this value "Wire Calib Error" displays at Home Position. Increase this parameter to clear error, or alternatively make new weight table, or replace wire drum/wire.	0.0 mm	Set	0 - 99999.9	175

Matrix group	Function group	Item	Access code	Short description	Default value	Set Select Display	Possible settings, selection, or display	Index No, GVH
CALIBRATION	AUTO CALIB. DISPL	CALIBR. AUTO/MAN	51	Select method for displacer weight calibration, useful when sludge attaches to displacer. When activated, Proservo will hoist displacer into drum housing and check weight of displacer against data in G3V4H2. "Manual" setting is recommended to avoid unwanted calibration during tank loading etc.	NONE	Select	0 - 2	180
		START TIME	51	Set start time for Auto Displacer Calibration. Available if G1V8H0 = "Auto"	99123123	Set	0 - 999999	181
		INTERVAL TIME	51	Set interval time between automatic displacer calibration operations. Available when G1V8H0 = "Auto"	0 hour	Set	0 - 9999 hour	182
		AUTO COMPENSAT.	51	Select to automatically compensate for displacer weight deviation detected at calibration	OFF	Select	OFF ON	183
		ZERO CORRECTION	51	Displays displacer weight deviation detected at calibration.	0.0 g	Set	0 - 999.9	184
		COMPENS. LIMIT	51	Set upper limit for automatic compensation of displacer weight. When G1V8H5 equals or exceeds this value "Displ Calib Error" displays at Home Position. Increase this parameter to clear error, or alternatively make new weight table, or clean displacer.	0.0 g	Set	0 - 99.9	185

Matrix group	Function group	Item	Access code	Short description	Default value	Set Select Display	Possible settings, selection, or display	Index No, GVH
CALIBRATION	DISPLAY	SELECT DISP. MODE	51	Select either "Ullage (Outage) Level" or "Measured (Image) Level".	MEASURED LEVEL	Select	ULLAGE LEVEL MEASURED LEVEL	190
		LANGUAGE	51	Select either "English" or "Japanese." [Chinese is also available by special order]	ENGLISH	Select	ENGLISH JAPANESE CHINESE	191
		LCD CONTRAST	51	Adjust LCD display module contrast.		Set	0 - 15	192
		YEAR SETTING	51	Calendar year.	Current year	Set	0 - 99	193
		MONTH SETTING	51	Calendar month.	Current month	Set	0 - 12	194
		DAY SETTING	51	Calendar day.	Current day	Set	0 - 31	195
		HOUR SETTING	51	Hour.	Current hour	Set	0 - 23	196
		MINUTE SETTING	51	Minute. Clock starts from 0 s when minute is set.	Current minute	Set	0 - 59	197
		SELECT DECIMAL	51	Selection of decimal point indication by dot or comma.	[.]	Select	[.], [,]	198
		LCD CHECK	51	When set = ON, display becomes dark as all pixels display for 3 seconds if normal. When set = OFF display become blank for 3 seconds if normal.	OFF	Select	OFF ON	199

Matrix group	Function group	Item	Access code	Short description	Default value	Set Select Display	Possible settings, selection, or display	Index No, GVH
DEVICE DATA	CONTACT OUTPUT	SELECT. RELAY	50	Use +/- and E keys to select to activate Contact Output Relays 1 to 4.	1	Select	Max 4	240
		ASSIGN RELAY	51	Select output definition from range of choices; None, Level, Liquid Temp, Caution, Warning, Emergency Error, Balance Signal.	NONE	Select	LEVEL, LIQUID TEMP, CAUTION, WARNING, EMERGENCY ERROR	241
		RELAY FUNCTION	51	Select High or Low function, available only when G2V4H1 = "Level" or "Liquid Temp."	HIGH	Select	HIGH LOW	242
		SWITCHING POINT	51	Set level at which relay is activated, available only when G2V4H1 = "Level" or "Liquid Temp."	0 mm	Set	Max. 99999 mm	243
		HYSTERISIS	50	Set hysteresis value for selected relay, available only when G2V4H1 = "Level" or "Liquid Temp."	0 mm	Set	Max. 9999 mm	244
		RELAY ON ALARM	50	Select from Normal Open or Normal close, available only when G2V4H1 = "Level" or "Liquid Temp."	NORMAL OPENED	Select	NORMAL OPEN NORMAL CLOSE	245
		ON DELAY TIME	50	Set delay time for alarm output start, available only when G2V4H1 = "Level" or "Liquid Temp."	0 s	Set	Max. 999 s	246
		OFF DELAY TIME	50	Set delay time for alarm spot, available only when G2V4H1 = "Level" or "Liquid Temp."	0 s	Select	Max. 999 s	247

Matrix group	Function group	Item	Access code	Short description	Default value	Set Select Display	Possible settings, selection, or display	Index No, GVH
DEVICE DATA	ANALOG OUT. ADJUST	ASSIGN OUTPUT 1	51	Assign analog output for channel 1.	NONE	Select	LEVEL LIQUID TEMP.	250
		ADJUST 4mA	51	Set level or temperature value for 4 mA output on channel 1. Available only when G2V5H0 = "Level" or "Liquid Temp"	0 mm /0°C	Set	FOR LIQUID TEMP. 0.0	251
		ADJUST 20mA	51	Set level or temperature value for 20 mA output on channel 1. Available only when G2V5H0 = "Level" or "Liquid Temp"	0 mm /0°C	Set	FOR LIQUID TEMP. 0.0	252
		ASSIGN OUTPUT 2	51	Assign analog output for channel 2.	NONE	Select	LEVEL LIQUID TEMP.	253
		ADJUST 4mA	51	Set level or temperature value for 4 mA output on channel 2. Available only when G2V5H3 = "Level" or "Liquid Temp"	0 mm /0°C	Set	FOR LIQUID TEMP. 0.0	254
		ADJUST 20mA	51	Set level or temperature value for 20 mA output on channel 2. Available only when G2V5H3 = "Level" or "Liquid Temp"	0 mm /0°C	Set	FOR LIQUID TEMP. 0.0	255
		DEVICE AT ALARM	51	Select type of output for alarm. Select from OFF, HOLD current output, Maximum value or Minimum value	OFF	Select	HOLD CURNT. OUT MAX MIN	256

Matrix group	Function group	Item	Access code	Short description	Default value	Set Select Display	Possible settings, selection, or display	Index No, GVH
DEVICE DATA	PARTS DATA	PARTS NUMBER	51	Set number for control-target parts (inside Proservo) to monitor.	1	Select	Max. 10	260
		PARTS TYPE	51	Select type of part to monitor.	NONE	Select	NONE, LEVEL, LIQUID TEMP, CUTTION, WARNING, EMEARGENCY ERROR	261
		MAINTEN. FACTOR	51	Select method of monitoring part, either Operation Hours or Drum Revolutions.	OPERATION HOUR	Select	OPERATION HOUR DRUM REVILT.	262
		MAINTEN. VALUE	51	Set the target maintenance (hours or revolutions) value for selected parts	1 hour or 0 Round	Set	999999 hour	263
		OPERATION TIME	51	Displays the accumulated operation time or revolutions for selected part. Note : Reset this value to 0 after parts replacement.	0 hour or 0 Round	Display/ set	999999 hour	264
		(Parts Overused Data)	51	Displays date when parts reached target value set in G2V6H3. Data format : yy mm dd hh mm.	POWER UNIT	Display		265
		REPLACED PARTS	51	Select part that has been replaced	NONE	Select		266
		(Parts Replaced Data)	51	Displays date when parts were replaced. Data format : yy mm dd hh mm.	NONE	Display		267

Matrix group	Function group	Item	Access code	Short description	Default value	Set Select Display	Possible settings, selection, or display	Index No, GVH
DEVICE DATA	INPUT SIGNAL	OPE. CONTACT	51	Displacer operation by contact input. Available if Contact Input (I/O 3 card) function is installed. Display shows either "NONE" or "Activated"	NONE	Select	NONE ACTIVATED	270
		CUSTODY TRANSFER	51	Displacer indicates whether Custody Transfer software is installed and activated or not (OFF or ON).	OFF	Display	OFF, ON	271
		NEW NMS STATUS	51	Switches NMS Status codes between old and new version, new version includes new operations and statuses. Note : For Rackbus communication, it is necessary to define "Operating Status"as On or OFF.	DISABLED	Select	DISABLED ENABLED	272
		SW VERSION	51	Displays software version of NMS 53x Proservo.	4.xx	Display		275
		HW VERSION	51	Displays hardware version of NMS 53x Proservo. "2.00" = TCB-2, "4.00" = TCB - 4, "6.00 = TCB - 6"	-	Display		276
		OPE. DENSITY	51	Displays liquid density setting used for computing buoyancy from a given balance volume in custody transfer mode.	1.00g/mL	Set	0 - 3.000	278
		OPE. CONT. STATUS	51	Displays the terminal numbers in use (binary converted to decimal)	0	Set	2 - 256	279

Matrix group	Function group	Item	Access code	Short description	Default value	Set Select Display	Possible settings, selection, or display	Index No, GVH	
DEVICE DATA	COMMUNICATION	LEVEL ALARM 1	51	Select Upper or Lower limit on image level relative to setting of Alarm 1 for bi-directional 2-wire communications.	HIGH	Select	HIGH LOW NONE	280	
		SET LEVEL ALARM 1	51	Set alarm output level for Alarm 1	0.0 mm	Set	Max. 99999.9 mm	281	
		LEVEL ALARM 2	51	Select Upper or Lower limit on image level relative to setting of Alarm 2 for bi-directional 2-wire communications.	HIGH	Select	HIGH LOW NONE	282	
		SET LEVEL ALARM 2	51	Set alarm output level for Alarm 2	0.0 mm	Set	Max. 99999.9 mm	283	
		HYSTERESIS	51	Set hysteresis for Alarm 1 and 2	0.0 mm	Set	Max. 99999.9 mm	284	
		ADDRESS	51	Set address. Range is 0-9, 00-FF (FF is fixed for MIC protocol or 1-247 Modbus) for remote/multi-drop communications.	0	Set	0 - FF for MIC.->FF Fixed 1 - 247/Modbus	285	
		PROTOCOL	51	Select communications protocol for remote/multi-drop communication	WM550, M/S	Select	BBB, MIDP, V1/ENRAF, RACK BUS, HART, MarkSpace, WM550, MODBUS	286	
		COMMU. LINE ADJ	51	Adjust line resistance for serial pulse V1 communications.	F	Set	0 - F	287	
		COMMUNIC. STATUS	51	Displays current communication status with Host. (See NMS Status Code)	0	Display		288	
		MODBUS Config		Set configuration of Modbus communication. Modbus parameters for G2V8H9		0	Set	0 - 14	289
			0: 1200 bps /Even	3: 2400 bps /Even	6: 4800 bps /Even	9: 9600 bps /Even	12: 19200 bps /Even		
			1: 1200 bps /Odd	4: 2400 bps /Odd	7: 4800 bps /Odd	10: 9600 bps /Odd	13: 19200 bps /Odd		
			2: 1200 bps /None	5: 2400 bps /None	8: 4800 bps /None	11: 9600 bps /None	14: 19200 bps /None		

Matrix group	Function group	Item	Access code	Short description	Default value	Set Select Display	Possible settings, selection, or display	Index No, GYH	
DEVICE DATA	STATUS	STATUS 1 DELAY	51	Set delay time between activation of Status 1 ON input signal and Status 1 output signal.	0 s	Set	0 s - 99 s	290	
		SELECT CONTACT	51	Select normal relay condition for Status1: Normal Open or Normal Closed.	NONE	Select	NONE NORMAL OPENED NORMAL CLOSED (ALARM = OPEN) (ALARM = CLOSED)	291	
	WM550 ALM. SELECT	51	Set the Alarm Bit for WM550 communication. (Available only with WM550 specification)	1	Select	1 - 3	292		
	WM550 BSW SELECT	51	Select source of BSW level data for WM550 communication. "0" = Upper I/F Level, "1" = (NMT539)Water Bottom level. (Available only WM550 specification)	0	Select	0 - 1	293		
	WM550 DENS. SEL.	51	Select source of data transmit in response to task 17, Sub-task 11 query. (Available only with WM550 specification)	0	Select	0 - 2	294		
	WM550 SW_ID_20xx	51	Set the last 2 digits (xx) of the WM550 sensor address (20xx). (Available only with WM550 specification)	37	Set	0 - 99	295		
	BALANCE DELAY	51	Seis time between displacer balance and Balance Signal output.	0 s	Set	0 s - 99 s	299		

Matrix group	Function group	Item	Access code	Short description	Default value	Set Select Display	Possible settings, selection, or display	Index No, GVH	
SERVICE	MEAS. WIRE & DRUM	WIRE DRUM CIRC.	51	Circumference of wire drum is measured at factory and inscribed on the wire drum. Used by CPU to calculate Measured Level	300.00 mm	Set	0 - 999.9	340	
		WIRE WEIGHT	51	Weight of measuring wire per 10 meters. Used by CPU to determine balance weight. Standard measuring wire is 1.40 g/10 m. PFA wire is 4.55 g/10 m. Hastelloy C wire is 2.48 g/10 m	1.40 g/10 m	Set	0 - 999.9	341	
		DISPLACER WEIGHT	51	Weight of displacer is measured at factory and inscribed on the wire drum. Used by CPU to calculate Measured and Interface Levels and densities.	255.0 g	Set	0 - 999.9	342	
		DISPLACER VOLUME	51	Total volume of displacer is measured at factory and inscribed on the wire drum. Used by CPU to calculate Interface Levels and Densities.	145.0 mL	Set	0 - 999.9	343	
		BALANCE VOLUME	51	Balance volume of displacer is measured at factory and inscribed on the wire drum, approximately one-half of Displacer Volume (G3V4H3). Used by CPU to calculate Measured and Interface Levels.	60 mL	Set	0 - 999.9	344	
		VOLUME TOLERANCE	51	Displacer immunity to variation in liquid surface level during Balance condition. Based on density = 1.0, setting for standard 50 mm displacer is 1.0 mL (1 g). Increase to counter turbulence and waves. Level accuracy varies inversely as Volume Tolerance.	1.0 mL	Set	0 - 99.9	345	
		DELAY	51	Interval until displacer responds to change in liquid level. Increase to counter small	20 x 100 mS	Set	0 - 99 x 100mS	347	
		DRUM CORRECTION	51	Used only for SW V2.xx		0.00 mm/m	Set	0 - 99.00	348
		DISPL. HUNT. COUNT	51	Defines the number of times displacer searches for balance condition. To balance on solid surface set = non-zero (e.g. 1)		0 count	Set	0 - 99	349

Matrix group	Function group	Item	Access code	Short description	Default value	Set Select Display	Possible settings, selection, or display	Index No, GVH	
SERVICE	GAUGE DATA	NON HYSTER. MODE	51	Non-Hysteresis Operation mode. When turned ON displacer is raised approx. 2mm and then seeks Balance condition again.	OFF	Select	OFF ON	352	
		HI. ACCURACY MODE	51	When displacer reaches Temporary Balance condition, it is raised (G3V5H5) millimeters, weighed, and then seeks Balance condition again.	OFF	Select	OFF ON	353	
		HI. ACCR. OPE TIME	51	Interval of Temporary Balance condition until displacer is raised and weighed.	0 s	Set	Set	0 - 600	354
		HI.ACC.DISP.UP	51	Distance displacer raised in High Accuracy Mode operation.	50 mm	Set	Set	0 - 300	355
		GAUGE TEMP.	51	Displays temperature inside electronics housing of NMS5/7.	999 °C	Display	Display		356
SERVICE	SYSTEM DATA	SENSOR DATA		Displays NMS5/7 Proservo specifications: software and hardware versions, remote communication (On/Off), drive gear ratio.	LOCAL: MASTER	Display	REMOVED.COM.ON SOFTWARE = xxx HARDWARE= TCBox GEAR 1:36 NOT OVERSPILL	360	
		CONNECTION NRF	51	Selects switch for communication to NRF 560 Promonitor. For NRF 560 SW v1.81 and before, select Contact 1. For NRF 560 SW v1.82 and later, select Contact 2.	OFF	Select	OFF CONTACT 1 CONTACT 2	361	
		CONNECTION NMT	51	Select switch for communication to NMT5/7 Series Prothermo. Select Average or Spot.	OFF	Select	OFF, SPOT TEMP. AVERAGE TEMP.	362	
		IF_LEVEL_SELECT	51	Select free scanning data source for water level (WM 550 only).		Select	UP_LEVEL_SELECT UP_IF_LEVEL WATER BOTTOM WATER BOTTOM 2		368
				Parameter Free scan data source					
		UP_IF_LEVEL NMS Proservo: Upper Interface Level or Water Dip Operation							
		WATER BOTTOM NMT539 WB: Water Bottom level data is taken for HART FreeScan. If Upper interface command is received from host via Sakura V1 communication, Water Bottom level is returned. Other operations return data based on the Proservo settings (Upper Interface or water Dip operation). Water Bottom data is taken via interrupt-scan in HART communication.							
		WATER BOTTOM 2 NMT 539 WB: Water Bottom level data is taken for HART FreeScan. Upper interface command returns data based on the Proservo settings (Upper Interface or Water Dip operation). Water Bottom data is taken via interrupt-scan in HART communication.							
		SOFT RESET	51	Restarts NMS5/7 Proservo software	OFF	Set		369	

Matrix group	Function group	Item	Access code	Short description	Default value	Set Select Display	Possible settings, selection, or display	Index No, GVH	
SERVICE	SERVICE	MEASURED WEIGHT		Displays tension on measuring wire as calculated by NMS CPU module.	0.0 g	Display	0.0 - 999 g	370	
		RELE. OVER TENS	51	Release displacer overtension condition. Note : First, set GOV2HO. Operation = STOP.	OFF	Select	OFF ON	371	
		DRUM SETTING	51	Aligns wire drum with internal detector unit. When displacer is shipped separately, and wire drum is removed to install displacer, set this function prior to making new Weight Calibration. Not required for All-in-One shipments of NMS5/7 Proservo.	OFF	Select	OFF ON	372	
		WEIGHT CALIBR.	51	Initiates Weight Table recalibration procedure. Overwrites existing weight table with new weight table. Caution!: Once recalibration procedure begins it must be completed, i.e. it cannot be stopped or reversed.	OFF	Select	OFF ON	373	
		DISPL. REFERENCE	51	Length for the starting position of weight calibration. The displacer will stop at this position without regard to the high stop level when it is hoisted, if the high stop level is set higher than this point.	70 mm	Set	10...999 mm	378	
	SERVICE VALUE	ZERO ADJ. WEIGHT	51	Low weight for weight calibration.	0.0 g	Set	0.0...999.9 g	379	
		SENSOR VALUE	51	Displays the A/D values from the encoder.	Sa ≈ 21000: A ≈ 21000 Sb ≈ 11000: B ≈ 11000	Display		380	
		SERVICE DATA	WT. COUNT CAL A	51	Displays A/D and displacer weight correction values for Sensor A Use the + and - key to scroll through 50 points.	0 0 0.0 g	Display		384
			WT. COUNT CAL B	51	Displays A/D and displacer weight correction values for Sensor B Use the + and - key to scroll through 50 points.	0 0 0.0 g	Display		395

Matrix group	Function group	Item	Access code	Short description	Default value	Set Select Display	Possible settings, selection, or display	Index No, GVH
TEMPERATURE	TEMPERATURE DATA	LIQUID TEMP.	51	Displays current average liquid temperature.	xx °C	Display	Depending on a specification and measured value.	440
		GAS TEMPERATURE	51	Displays current average gas temperature.	zz °C	Display	Depending on a specification and measured value.	441
		MEASURED LEVEL	51	Displays Measured Level data received from NMS5/7 Proservo, depending on selection at G4V4H3 Level Data Select.	aaaa.a mm	Display	Depending on a specification and measured value.	442
		LEV. DATA SELECT	51	Select level data to receive from NMS5/7 Proservo, used for averaging calculations. Select "VH00" to receive Measured Level (actual displacer position). Select "VH08" to receive Level Data (last recorded level position).	VH00	Select	VH00 or VH08	443
		WATER BOTTOM	51	Displays water level data from the NMT 539 Water Bottom. G3V6H8 must be set to either "WATER BOTTOM" or "WATER BOTTOM2"	0.0 mm	Display	Depending on a specification and measured value.	444
		DIAGNOSTIC	51	Displays reference resistance on circuit board corresponding to 0°C.	0.0 °C	Display	Depending on a specification and measured value.	447
		REFERENCE 150	51	Displays reference resistance on circuit board corresponding to 150°C.	150.0 °C	Display	Depending on a specification and measured value.	449

Matrix group	Function group	Item	Access code	Short description	Default value	Set Select Display	Possible settings, selection, or display	Index No, GVH
TEMPERATURE	ELEMENT TEMP. Depending on a specification and measured value.	TEMP. NO.1	51	Displays temperature of element 1 (lowest element).	aa.a °C	Display	-49.9 ... 249.9 °C	450
		TEMP. NO.2	51	Displays temperature of element 2.	bb.b °C	Display	-49.9 ... 249.9 °C	451
		TEMP. NO.3	51	Displays temperature of element 3.	cc.c °C	Display	-49.9 ... 249.9 °C	452
		TEMP. NO.4	51	Displays temperature of element 4.	dd.d °C	Display	-49.9 ... 249.9 °C	453
		TEMP. NO.5	51	Displays temperature of element 5.	ee.e °C	Display	-49.9 ... 249.9 °C	454
		TEMP. NO.6	51	Displays temperature of element 6.	ff.f °C	Display	-49.9 ... 249.9 °C	455
		TEMP. NO.7	51	Displays temperature of element 7.	gg.g °C	Display	-49.9 ... 249.9 °C	456
		TEMP. NO.8	51	Displays temperature of element 8.	hh.h °C	Display	-49.9 ... 249.9 °C	457
		TEMP. NO.9	51	Displays temperature of element 9.	ii.i °C	Display	-49.9 ... 249.9 °C	458
		TEMP. NO.10	51	Displays temperature of element 10.	jj.j °C	Display	-49.9 ... 249.9 °C	459

Matrix group	Function group	Item	Access code	Short description	Default value	Set Select Display	Possible settings, selection, or display	Index No, GVH
TEMPERATURE	ELEMENT POSITION Depending on a specification.	ELEM.1 POSITION	51	Displays position of element 1, also called "Bottom (lowest) Element.	xxx.x mm	Display	0 ... 99999 mm	460
		ELEM.2 POSITION	51	Displays temperature of element 2.	xxx.x mm	Display	0 ... 99999 mm	461
		ELEM.3 POSITION	51	Displays temperature of element 3.	xxx.x mm	Display	0 ... 99999 mm	462
		ELEM.4 POSITION	51	Displays temperature of element 4.	xxx.x mm	Display	0 ... 99999 mm	463
		ELEM.5 POSITION	51	Displays temperature of element 5.	xxx.x mm	Display	0 ... 99999 mm	464
		ELEM.6 POSITION	51	Displays temperature of element 6.	xxx.x mm	Display	0 ... 99999 mm	465
		ELEM.7 POSITION	51	Displays temperature of element 7.	xxx.x mm	Display	0 ... 99999 mm	466
		ELEM.8 POSITION	51	Displays temperature of element 8.	xxx.x mm	Display	0 ... 99999 mm	467
		ELEM.9 POSITION	51	Displays temperature of element 9.	xxx.x mm	Display	0 ... 99999 mm	468
		ELEM.10 POSITION	51	Displays temperature of element 10.	xxx.x mm	Display	0 ... 99999 mm	469

Matrix group	Function group	Item	Access code	Short description	Default value	Set Select Display	Possible settings, selection, or display	Index No, GVH
TEMPERATURE	NMT ADJUSTMENT	SELECT. POINT	51	Select element number for zero adjustment procedure. Selection begins at 0, which is element 1. Select 1 for element 2, etc. Also used to select elements 11-16 (input 10-15)	0	Select	0-15 Selectable 0(element No.1) 10(element No.11)	470
		ZERO ADJUST	51	Set zero adjustment value for element selected at G4V7H1.	0.0 °C	Set	-20.0 ...20.0°C	471
		GAIN ADJUST	51	Set gain adjustment value for temperature measurement. Caution!: This setting is made at factory before shipping and should not be adjusted in field.	1.000	Set		472
		ELEMENT TEMP	51	Displays temperature for element number 11-15 (16 element NMT modules only)	xx.x °C	Display	-49.9 ...249.9°C	473
		ELEMENT POSITION	51	Displays temperature for element number 11-15 (16 element NMT modules only) when selected at G4V7H0 Select Point.	xxx.x mm	Display	0 ...99999 mm	474
		AVERAGING	51	Set sampling coefficient for averaging data. Increase to counter noise factor.	2	Set	1 ...10	478
		ACCESS CODE	51	Displays current Access code.		Set		479

Matrix group	Function group	Item	Access code	Short description	Default value	Set Select Display	Possible settings, selection, or display	Index No, GVH
TEMPERATURE	SET DATA NMT	DIAGNOSTIC	51	Displays current NMT diagnostic code.	0	Display	0 ... 255	480
		TEMPERATURE UNIT	51	Displays selected temperature unit.	C	Display		481
		TOTAL NO. ELEMENT	51	Set total number of elements in NMT temperature sensor.	XX	Set	a ... A HEX	482
		PREAMBLE NUMBER	51	Display of preambles for HART protocol.	5	Display	2 ... 14 HEX	483
		LENGTH UNIT	51	Displays selected length unit.	mm	Display		484
		KIND OF INTERVAL	51	Select type interval between temperature elements. If Unequal is selected, must set element positions at G4V6 H0 to 9, G4V7H4	EQUAL	Select	EQUAL UNEQUAL	485
		BOTTOM POINT	51	Set position of element 1 (lowest element) above tank bottom. Available only when G4V8H5 = Equal.	500.0 mm	Set	0.0 mm to 500.0 mm valuable	486
		ELEMENT INTERVAL	51	Set spacing between elements. Available only when G4V8H5 = Equal.	2000.0 mm	Set	0.0 ... 99999.9 mm	487
		TEMP. ELEM. SHORT	51	Set temperature indication sent to NMS5/7 Proservo Home Position when element is shorted and G4V9H2 = ON. Default value = -49.5 °C	-49.5 °C	Set		488
		TEMP. ELEM. OPEN	51	Set temperature indication sent to NMS5/7 Proservo Home Position when element is open and G4V9H2 = ON. Default value = -359.0 °C	359.0 °C	Set		489

Matrix group	Function group	Item	Access code	Short description	Default value	Set Select Display	Possible settings, selection, or display	Index No, GVH	
TEMPERATURE	DEVICE DATA NMT	INSTRUMENT CODE	51	Displays hardware unit number.		Display		490	
		LAST DIAGNOSTIC	51	Displays last error message.		Display		491	
		OUTPUT AT ERROR	51	Select ON for output and indication in case of element short or element open condition.	ON	Select	OFF ON		492
		CUSTODY TRANSFER	51	Display status of custody transfer function.	OFF	Select	OFF ON		493
		POLLING ADDRESS	51	Select polling address (1-F) for NMT535/539/532 Prothermo for use in multi-drop applications. Set address 3 for connection with NMS5/7 Proservo	2	Select	1 ... F (Total 16 address can be set)		494
		MANUFACTURE ID	51	Displays identification number for NMT535/539/532 Prothermo. 17=Endress+Hauser	17	Display			495
		SW VERSION	51	Displays software version of NMT535/539/532 Prothermo.	5	Display	4.0 or higher		496
		HW VERSION	51	Displays hardware version of NMT535/539/532 Prothermo.	2	Display	1.4 or higher		497
		BELOW BOT. POINT	530	Select ON to cancel "NMT Below Bottom Point" error message output to NMS when displacer sinks below lowest temperature element.		ON	Select		498
		DEVICE TYPE CODE	51	Displays device type code for NMT535/539/532 Prothermo.		DEVICE	Display		499

Matrix group	Function group	Item	Access code	Short description	Default value	Set Select Display	Possible settings, selection, or display	Index No, GVH
HART DEVICE	MEASURED VALUE	PV DATA		Displays primary variable data of the HART Device.		Display		540
		SV DATA		Displays secondary variable data of the HART Device.		Display		541
		HART DEVICE (1)	51	Select HART Device I function: OFF, ON, Liquid Temperature, Gas Temperature. If "Liquid Temperature" is selected, value is reflected at GOV1H0 and GOV1H1	OFF	Select	OFF LIQUID TEMP. GAS TEMPERATURE ON	549
P.V.SETTING		P.V.RANGE UNIT	51	Setting of range unit for primary variable in HART command code.		Set		550
		P.V.UPPER RANGE	51	Setting of upper range of primary variable.		Set		551
		P.V.LOWER RANGE	51	Setting of lower range of primary variable.		Set		552
		DAMP VALUE	51	Setting of damping of primary variable.		Set		553
		SENSOR SERIAL NO		Displays sensor serial number		Display		560
SENSOR SPECIFIC		UPPER SENSOR LMT		Displays upper limit of the HART Device.		Display		561
		LOWER SENSOR LMT		Displays upper limit of the HART Device.		Display		562

Matrix group	Function group	Item	Access code	Short description	Default value	Set Select Display	Possible settings, selection, or display	Index No, GVH	
HART DEVICE	SELF DIAGNOSTIC Consult HART device operation/service manual	ERROR CODE (1)		Displays of the error code (1) the HART device.		Display		580	
		ERROR CODE (2)		Displays of the error code (2) the HART device.		Display		581	
		ERROR CODE (3)		Displays of the error code (3) the HART device.		Display		582	
		ERROR CODE (4)		Displays of the error code (4) the HART device.		Display		583	
		ERROR CODE (5)		Displays of the error code (5) the HART device.		Display		584	
	DEVICE DATA	POLLING ADDRESS			Displays polling address of HART Device 1. Address (fixed) = 4.	4	Display		591
		MANUFACTURE ID			Displays manufacturer ID number of the HART Device.		Display		592
		DEVICE TYPE CODE			Displays device type code of the HART Device.		Display		593
		PREAMBLES			Set number of preambles for the HART device.		Display		594
		SW VERSION			Displays the software version for the HART device.		Display		595
		HW VERSION			Displays the hardware version for the HART device.		Display		596
		DEVICE ID			Displays the device ID for the HART device.		Display		597

Matrix group	Function group	Item	Access code	Short description	Default value	Set Select Display	Possible settings, selection, or display	Index No, GVH	
HART DEVICE	MEASURED VALUE	PV DATA		Displays primary variable data of the HART Device.		Display		640	
		SV DATA		Displays secondary variable data of the HART Device.		Display		641	
		HART DEVICE (2)	51	Select HART Device 2 function: OFF, ON, Gas Temperature. If "Gas Temperature" is selected, value is reflected at GOV1H0 and GOV1H1	OFF	Select	OFF LIQUID TEMP. GAS TEMPERATURE ON	649	
	P.V.SETTING	P.V.RANGE UNIT	51	Setting of range unit for primary variable in HART command code.			Set		650
		P.V.UPPER RANGE	51	Setting of upper range of primary variable.			Set		651
		P.V.LOWER RANGE	51	Setting of lower range of primary variable.			Set		652
		DAMP VALUE	51	Setting of damping of primary variable.			Set		653
	SENSOR SPECIFIC	SENSOR SERIAL NO			Displays sensor serial number		Display		660
		UPPER SENSOR LMT			Displays upper limit of the HART Device.		Display		661
		LOWER SENSOR LMT			Displays lower limit of the HART Device.		Display		662

Matrix group	Function group	Item	Access code	Short description	Default value	Set Select Display	Possible settings, selection, or display	Index No, GVH	
HART DEVICE	SELF DIAGNOSTIC Consult HART device operation/service manual	ERROR CODE (1)		Displays of the error code (1) the HART device.		Display		680	
		ERROR CODE (2)		Displays of the error code (2) the HART device.		Display		681	
		ERROR CODE (3)		Displays of the error code (3) the HART device.		Display		682	
		ERROR CODE (4)		Displays of the error code (4) the HART device.		Display		683	
		ERROR CODE (5)		Displays of the error code (5) the HART device.		Display		684	
	DEVICE DATA	POLLING ADDRESS			Displays polling address of HART Device 2. Address (fixed) = 5.	5	Display		691
		MANUFACTURE ID			Displays manufacturer ID number of the HART Device.		Display		692
		DEVICE TYPE CODE			Displays device type code of the HART Device.		Display		693
		PREAMBLES			Set number of preambles for the HART device.		Set		694
		SW VERSION			Displays the software version for the HART device.		Display		695
		HW VERSION			Displays the hardware version for the HART device.		Display		696
		DEVICE ID			Displays the device ID for the HART device.		Display		697

Matrix group	Function group	Item	Access code	Short description	Default value	Set Select Display	Possible settings, selection, or display	Index No, GVH	
ADJ. SENSOR	UNIT	LEV. UNIT (HOST)	51	Select display units for level value data to be sent to host CPU via remote communications	mm	Select	m, inch, cm, ft	760	
		TEMP UNIT (HOST)	51	Select units for temperature value data to be sent to host CPU via remote communications	°C	Select	°C, °F, °R, °K	761	
		DEN. UNIT (HOST)	51	Select display units for density value data to be sent to host CPU via remote communications	g/mL	Select	Kg/m ³ , lb/gal, SGU, Kg/l, g/l, lb/in, sl/y ³	762	
		LEV. UNIT	51	Select units for level value data displayed locally at NMS/NRF.	mm	Select	m, inch, cm, ft	765	
		TEMP. UNIT	51	Select units for temperature data displayed locally at NMS/NRF	°C	Select	°C, °F, °R, °K	766	
		DEN. UNIT	51	Select units for density value data displayed locally at NMS/NRF	g/mL	Select	Kg/m ³ , lb/gal, SGU, Kg/l, g/l, lb/in, sl/y	767	
		HART LINE	NMT	777	Select Terminal Port A (Ex ia) or Terminal Port B (Ex d) for the NMT connection	TERMINAL PORT B	Set	TERMINAL PORT B TERMINAL PORT A	770
			HART DEVICE (1)	777	Select Terminal Port A (Ex ia) or Terminal Port B (Ex d) for the HART Device 1.	TERMINAL PORT B	Set	TERMINAL PORT B TERMINAL PORT A	771
			HART DEVICE (2)	777	Select Terminal Port A (Ex ia) or Terminal Port B (Ex d) for the HART Device 2.	TERMINAL PORT B	Set	TERMINAL PORT B TERMINAL PORT A	772
		INTERFACE ADJUST	VOL. TOL. FOR I/F	51	Set Volume Tolerance for Balance condition during Interface measurement	0.3 mL	Set	0 - 99.9 mL	780
BRAKE RATE	51		Used for Interface Measurement. Increase Brake Rate to make the balance zone smaller and decrease interface measurement time.	150	Display	0 - 255	781		
BALANCE COUNT	51		Used for Interface Measurement. Balance signal is generated after motor movement changes from fast to slow specified number of times. Coordinate this setting with G2Y9H9 Balance Delay setting.	15	Display	0 - 255	782		
IF 1 OFFSET	51		Change this setting to correct Interface 1 level deviation.	0.0 mm	Display	0 - 9999.9 mm	783		
		IF 2 OFFSET	51	Change this setting to correct Interface 2 level deviation.	0.0 mm	Display	0 - 9999.9 mm	784	

Matrix group	Function group	Item	Access code	Short description	Default value	Set Select Display	Possible settings, selection, or display	Index No, GVH
TANK PROFILE	PROFILE OPE. NOTE: Data in G8V4H0 to G8V4H9 are used for both Tank and Interface Profile measurement	OPE. SELECT	51	Select method for density measurement. 0: spot. 1: Tank Profile. 2: I/F Profile. 3: MANU. I/F Profile.	0: stop	Select	0: stop 1: tank profile 2: I/F profile 3: MANU. I/F profile	840
		OPE. POINT	51	Set the number of measurement points for Tank Profile measurement.	2	Set	2 - 16	841
		I/F MANU. LEVEL	51	Manually set the water interface level to be referenced during Tank Profile measurement.	0 mm	Set	0 - 99999.9 mm	843
		BAL. LEVEL	51	Set the allowance for level movement prior to Tank Profile operation. If level movement exceeds this value, Profile operation is canceled. Setting 99.9 mm allows Profile measurement to proceed, regardless of level movement	2.0 mm	Set	1.0 - 99.9 mm	844
		UP WAIT TIME	51	Set waiting time for displacer weight to be measured in air, when making the weight table at start of Profile operation	1 min.	Set	1 - 31 min	845
		LIC. WAIT TIME	51	Set the time for displacer to stop at each measurement position during profile operation	1 min.	Set	1 - 31 min	846
		OPE. WAIT TIME	51	E.g. if level movement exceeds setting at C8V4H4, Proservo is in "stand by" for the time set in this matrix. After the maximum time elapses, profile operation is canceled.	1 min.	Set	1 - 31 min	847

Matrix group	Function group	Item	Access code	Short description	Default value	Set Select Display	Possible settings, selection, or display	Index No, GVH	
TANK PROFILE	STATUS/DATA	OPE. STATUS		Displays profile operation status.	0	Display	0 - 6	850	
				0: Accepting					
				1: Standby					
				2: In operation					
				3: OPR.END					
				4: UN_BALANCE ERR					
	5: OPR. ERR. STOP								
			LEVEL CONDITION		Displays status of liquid level/surface monitored prior to profile operation.	0	Display	0 - 4	851
					0: Off Level Meas				
					1: Stable				
2: Unstable									
3: Ignor Condition									
		OPE. TIME		Displays time when Tank Profile operation finished (DD/HH/MM)	DDHHMM	Display	000000 - 312359	852	
				AVERAGE DENSITY					
				AVERAGE TEMP.					
				DIAG. CODE					

Matrix group	Function group	Item	Access code	Short description	Default value	Set Select Display	Possible settings, selection, or display	Index No, GVH
TANK PROFILE	DENSITY1 - 10	NO. 1 DENSITY		Displays density values for point No.1 in density profile	0.000 g/ml	Display	0.000 - 9.999 g/ml	860
		NO. 2 DENSITY		Displays density values for point No.2 in density profile	0.000 g/ml	Display	0.000 - 9.999 g/ml	861
		NO. 3 DENSITY		Displays density values for point No.3 in density profile	0.000 g/ml	Display	0.000 - 9.999 g/ml	862
		NO. 4 DENSITY		Displays density values for point No.4 in density profile	0.000 g/ml	Display	0.000 - 9.999 g/ml	863
		NO. 5 DENSITY		Displays density values for point No.5 in density profile	0.000 g/ml	Display	0.000 - 9.999 g/ml	864
		NO. 6 DENSITY		Displays density values for point No.6 in density profile	0.000 g/ml	Display	0.000 - 9.999 g/ml	865
		NO. 7 DENSITY		Displays density values for point No.7 in density profile	0.000 g/ml	Display	0.000 - 9.999 g/ml	866
		NO. 8 DENSITY		Displays density values for point No.8 in density profile	0.000 g/ml	Display	0.000 - 9.999 g/ml	867
		NO. 9 DENSITY		Displays density values for point No.9 in density profile	0.000 g/ml	Display	0.000 - 9.999 g/ml	868
		NO. 10 DENSITY		Displays density values for point No.10 in density profile	0.000 g/ml	Display	0.000 - 9.999 g/ml	869
	DENSITY11 - 16	NO. 11 DENSITY		Displays density values for point No.11 in density profile	0.000 g/ml	Display	0.000 - 9.999 g/ml	870
		NO. 12 DENSITY		Displays density values for point No.12 in density profile	0.000 g/ml	Display	0.000 - 9.999 g/ml	871
		NO. 13 DENSITY		Displays density values for point No.13 in density profile	0.000 g/ml	Display	0.000 - 9.999 g/ml	872
		NO. 14 DENSITY		Displays density values for point No.14 in density profile	0.000 g/ml	Display	0.000 - 9.999 g/ml	873
		NO. 15 DENSITY		Displays density values for point No.15 in density profile	0.000 g/ml	Display	0.000 - 9.999 g/ml	874
		NO. 16 DENSITY		Displays density values for point No.16 in density profile	0.000 g/ml	Display	0.000 - 9.999 g/ml	875

Matrix group	Function group	Item	Access code	Short description	Default value	Set Select Display	Possible settings, selection, or display	Index No, GVH
TANK PROFILE	POSITION1 - 10	NO. 1 POSITION		Displays position No.1 of measurement taken during density profile.	0 mm	Display	0 - 99999,9 mm	880
		NO. 2 POSITION		Displays position No.2 of measurement taken during density profile.	0 mm	Display	0 - 99999,9 mm	881
		NO. 3 POSITION		Displays position No.3 of measurement taken during density profile.	0 mm	Display	0 - 99999,9 mm	882
		NO. 4 POSITION		Displays position No.4 of measurement taken during density profile.	0 mm	Display	0 - 99999,9 mm	883
		NO. 5 POSITION		Displays position No.5 of measurement taken during density profile.	0 mm	Display	0 - 99999,9 mm	884
		NO. 6 POSITION		Displays position No.6 of measurement taken during density profile.	0 mm	Display	0 - 99999,9 mm	885
		NO. 7 POSITION		Displays position No.7 of measurement taken during density profile.	0 mm	Display	0 - 99999,9 mm	886
		NO. 8 POSITION		Displays position No.8 of measurement taken during density profile.	0 mm	Display	0 - 99999,9 mm	887
		NO. 9 POSITION		Displays position No.9 of measurement taken during density profile.	0 mm	Display	0 - 99999,9 mm	888
		NO. 10 POSITION		Displays position No.10 of measurement taken during density profile.	0 mm	Display	0 - 99999,9 mm	889
	DENSITY11 - 16	NO. 11 POSITION		Displays position No.11 of measurement taken during density profile.	0 mm	Display	0 - 99999,9 mm	890
		NO. 12 POSITION		Displays position No.12 of measurement taken during density profile.	0 mm	Display	0 - 99999,9 mm	891
		NO. 13 POSITION		Displays position No.13 of measurement taken during density profile.	0 mm	Display	0 - 99999,9 mm	892
		NO. 14 POSITION		Displays position No.14 of measurement taken during density profile.	0 mm	Display	0 - 99999,9 mm	893
		NO. 15 POSITION		Displays position No.15 of measurement taken during density profile.	0 mm	Display	0 - 99999,9 mm	894
		NO. 16 POSITION		Displays position No.16 of measurement taken during density profile.	0 mm	Display	0 - 99999,9 mm	895

Matrix group	Function group	Item	Access code	Short description	Default value	Set Select Display	Possible settings, selection, or display	Index No, GVH	
INTERFACE PROFILE	STATUS/DATA	OPE. STATUS		Displays profile operation status.	0	Display	0 - 6	950	
				0: Accepting					
				1: Standby					
				2: In operation					
				3: OPR.END					
				4: UN_BALANCE ERR					
	5: OPR. ERR. STOP								
			LEVEL CONDITION		Displays status of liquid level/surface monitored prior to profile operation.	0	Display	0 - 4	951
					0: Off Level Meas				
					1: Stable				
2: Unstable									
3: Ignor Condition									
		OPE. TIME		Displays time when Interface Profile operation finished (DD/HH/MMM).	DDHHMM	Display	000000 - 312359	952	
				I/F LEVEL					
				AVERAGE DENSITY					
				AVERAGE TEMP.					

Matrix group	Function group	Item	Access code	Short description	Default value	Set Select Display	Possible settings, selection, or display	Index No, GVH
TANK PROFILE	DENSITY1 - 10	NO. 1 DENSITY		Displays density values for point No.1 in density profile	0.000 g/ml	Display	0.000 - 9.999 g/ml	960
		NO. 2 DENSITY		Displays density values for point No.2 in density profile	0.000 g/ml	Display	0.000 - 9.999 g/ml	961
		NO. 3 DENSITY		Displays density values for point No.3 in density profile	0.000 g/ml	Display	0.000 - 9.999 g/ml	962
		NO. 4 DENSITY		Displays density values for point No.4 in density profile	0.000 g/ml	Display	0.000 - 9.999 g/ml	963
		NO. 5 DENSITY		Displays density values for point No.5 in density profile	0.000 g/ml	Display	0.000 - 9.999 g/ml	964
		NO. 6 DENSITY		Displays density values for point No.6 in density profile	0.000 g/ml	Display	0.000 - 9.999 g/ml	965
		NO. 7 DENSITY		Displays density values for point No.7 in density profile	0.000 g/ml	Display	0.000 - 9.999 g/ml	966
		NO. 8 DENSITY		Displays density values for point No.8 in density profile	0.000 g/ml	Display	0.000 - 9.999 g/ml	967
		NO. 9 DENSITY		Displays density values for point No.9 in density profile	0.000 g/ml	Display	0.000 - 9.999 g/ml	968
		NO. 10 DENSITY		Displays density values for point No.10 in density profile	0.000 g/ml	Display	0.000 - 9.999 g/ml	969
	DENSITY11 - 16	NO. 11 DENSITY		Displays density values for point No.11 in density profile	0.000 g/ml	Display	0.000 - 9.999 g/ml	970
		NO. 12 DENSITY		Displays density values for point No.12 in density profile	0.000 g/ml	Display	0.000 - 9.999 g/ml	971
		NO. 13 DENSITY		Displays density values for point No.13 in density profile	0.000 g/ml	Display	0.000 - 9.999 g/ml	972
		NO. 14 DENSITY		Displays density values for point No.14 in density profile	0.000 g/ml	Display	0.000 - 9.999 g/ml	973
		NO. 15 DENSITY		Displays density values for point No.15 in density profile	0.000 g/ml	Display	0.000 - 9.999 g/ml	974
		NO. 16 DENSITY		Displays density values for point No.16 in density profile	0.000 g/ml	Display	0.000 - 9.999 g/ml	975

Matrix group	Function group	Item	Access code	Short description	Default value	Set Select Display	Possible settings, selection, or display	Index No, GVH
TANK PROFILE	POSITION1 - 10	NO. 1 POSITION		Displays position No.1 of measurement taken during density profile.	0 mm	Display	0 - 99999,9 mm	980
		NO. 2 POSITION		Displays position No.2 of measurement taken during density profile.	0 mm	Display	0 - 99999,9 mm	981
		NO. 3 POSITION		Displays position No.3 of measurement taken during density profile.	0 mm	Display	0 - 99999,9 mm	982
		NO. 4 POSITION		Displays position No.4 of measurement taken during density profile.	0 mm	Display	0 - 99999,9 mm	983
		NO. 5 POSITION		Displays position No.5 of measurement taken during density profile.	0 mm	Display	0 - 99999,9 mm	984
		NO. 6 POSITION		Displays position No.6 of measurement taken during density profile.	0 mm	Display	0 - 99999,9 mm	985
		NO. 7 POSITION		Displays position No.7 of measurement taken during density profile.	0 mm	Display	0 - 99999,9 mm	986
		NO. 8 POSITION		Displays position No.8 of measurement taken during density profile.	0 mm	Display	0 - 99999,9 mm	987
		NO. 9 POSITION		Displays position No.9 of measurement taken during density profile.	0 mm	Display	0 - 99999,9 mm	988
		NO. 10 POSITION		Displays position No.10 of measurement taken during density profile.	0 mm	Display	0 - 99999,9 mm	989
	DENSITY11 - 16	NO. 11 POSITION		Displays position No.11 of measurement taken during density profile.	0 mm	Display	0 - 99999,9 mm	990
		NO. 12 POSITION		Displays position No.12 of measurement taken during density profile.	0 mm	Display	0 - 99999,9 mm	991
		NO. 13 POSITION		Displays position No.13 of measurement taken during density profile.	0 mm	Display	0 - 99999,9 mm	992
		NO. 14 POSITION		Displays position No.14 of measurement taken during density profile.	0 mm	Display	0 - 99999,9 mm	993
		NO. 15 POSITION		Displays position No.15 of measurement taken during density profile.	0 mm	Display	0 - 99999,9 mm	994
		NO. 16 POSITION		Displays position No.16 of measurement taken during density profile.	0 mm	Display	0 - 99999,9 mm	995

13 Appendix

13.1 RS 485 MODBUS (COM- 5) Terminator

How to set Terminator switch

1.RS- 485 Communication module until 2008

Set all slide switch (four bits) turn to ON when termination is required.

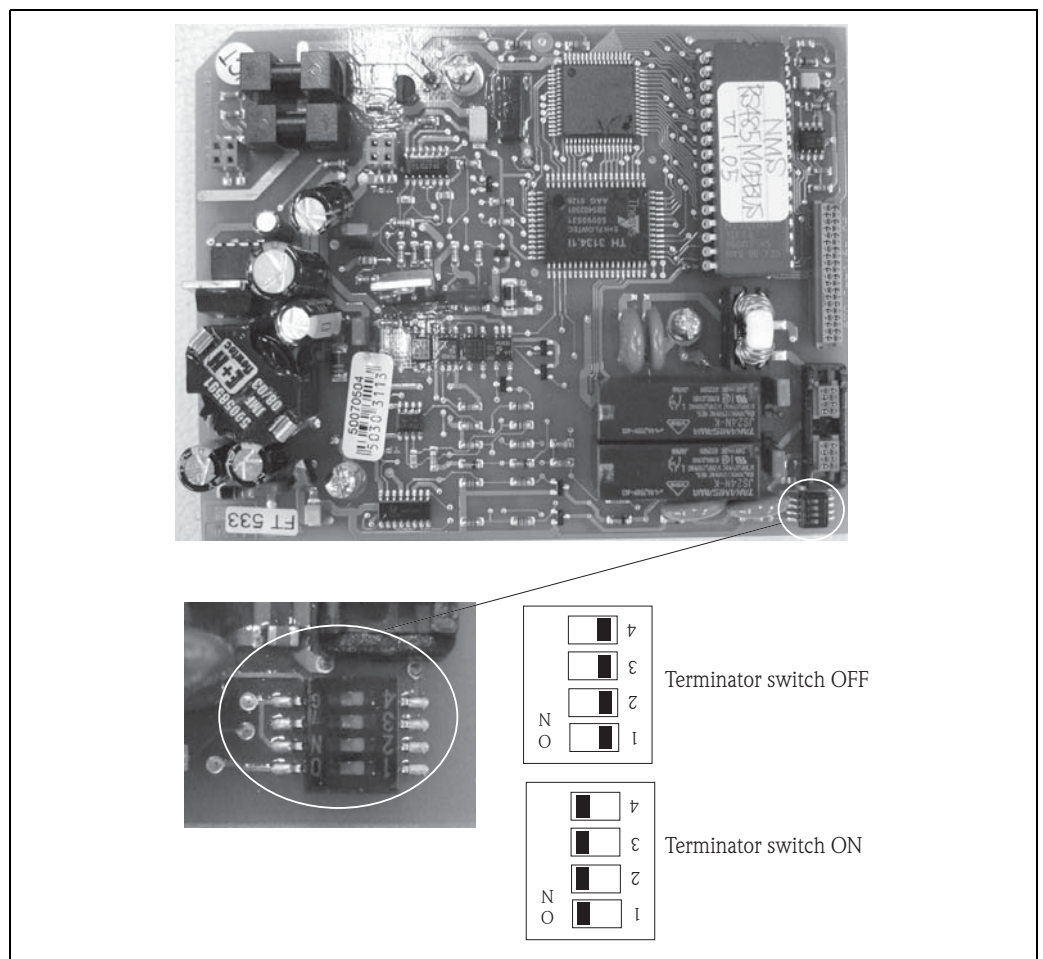

2. COMM-5 RS- 485 Communication module from 2009

Set all piano type switch 1 - 1 and switch 2 - 3, 2 - 4 turn to ON (UP) when termination is required.

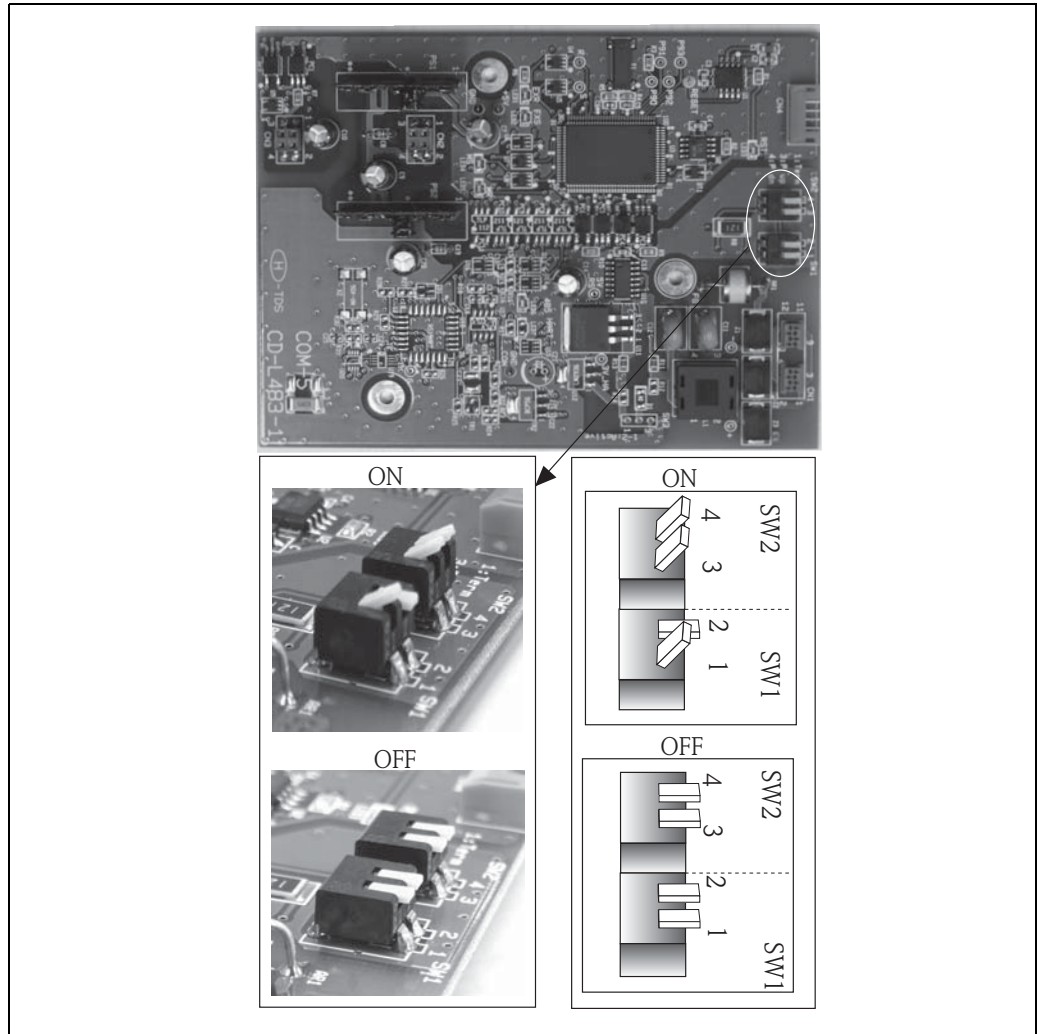

13.2 Changing measurement wire

Winding wire onto wire drum

1. Prepare a box with approx. 300mm(w) × 300mm(d) × 50mm(h) for wire storing.
2. Take out the measurement wire from the plastic bag.
3. Put the wire into the box without twisting.
4. Put one end of the wire into a hole on wire drum groove.
5. Fix the end of the wire by screw.
6. Sit down on a chair.
7. Grasp drum by left hand and hold wire by left thumb.
8. Hold wire by right thumb and index finger.
9. Make tension to secure the wire, so as not to come out of the groove.
10. Rotate the wire drum to wind the wire into groove with holding by left thumb.

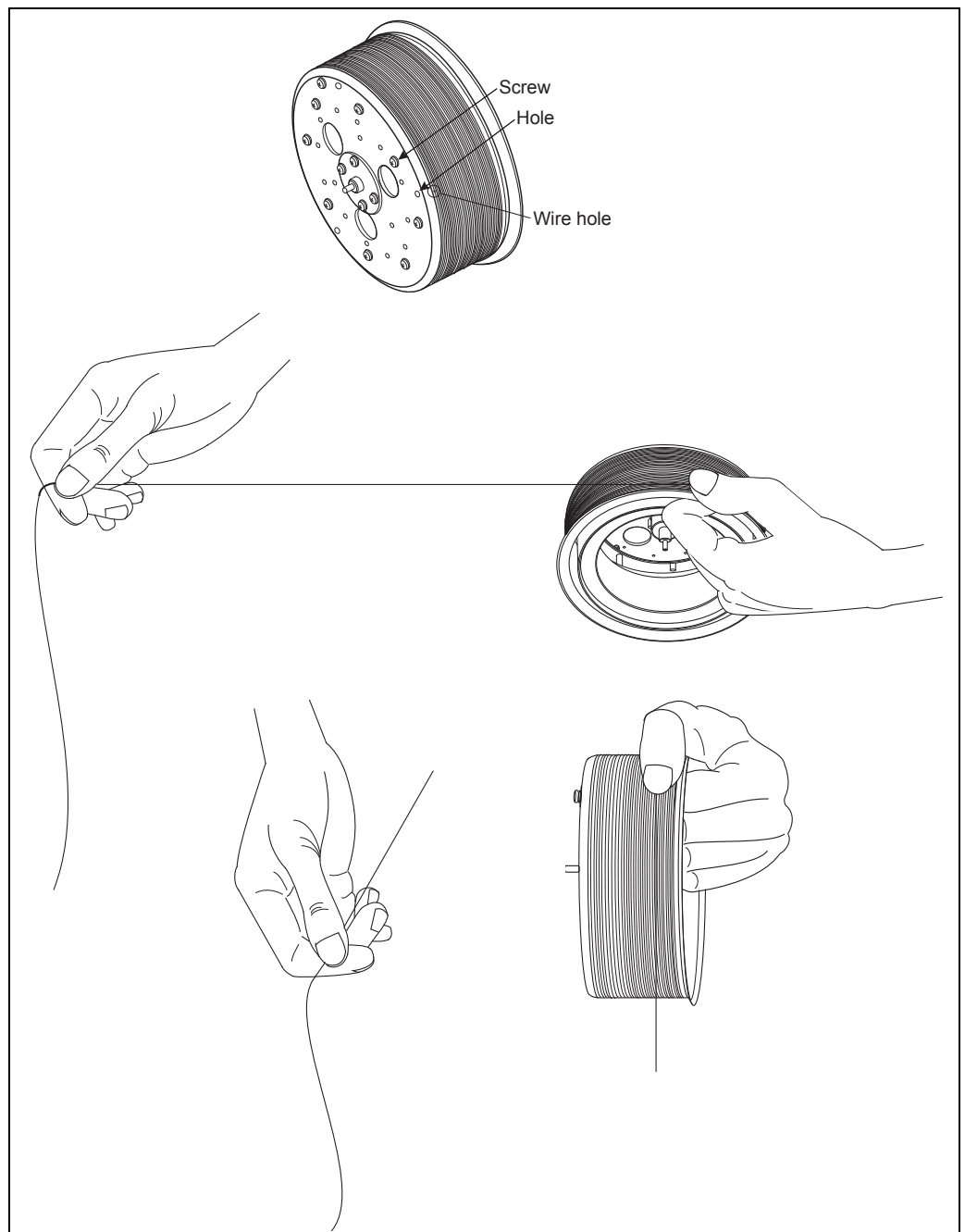

Fixing wire ring

1. Put wire drum on desk and fix the wire by masking tape remaining 500mm wire.

2. Set wire ring according to following procedure.

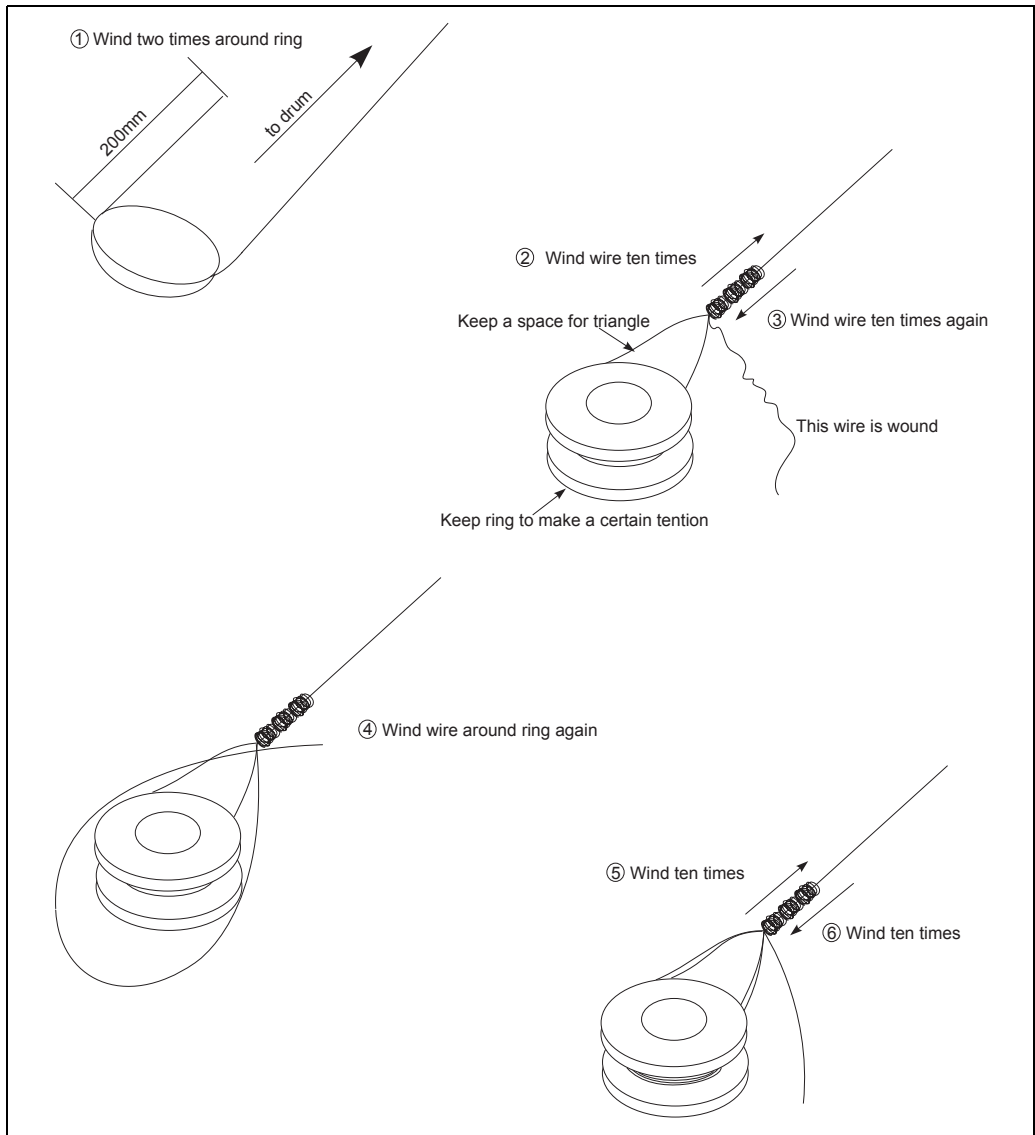
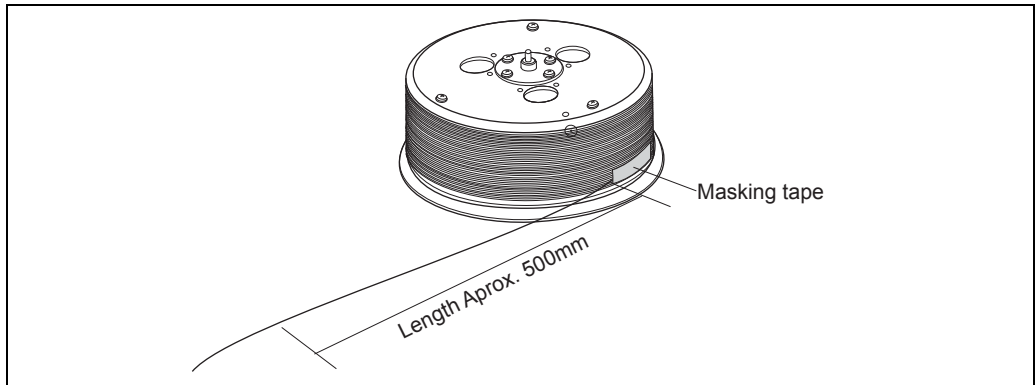

13.3 Displacer draft

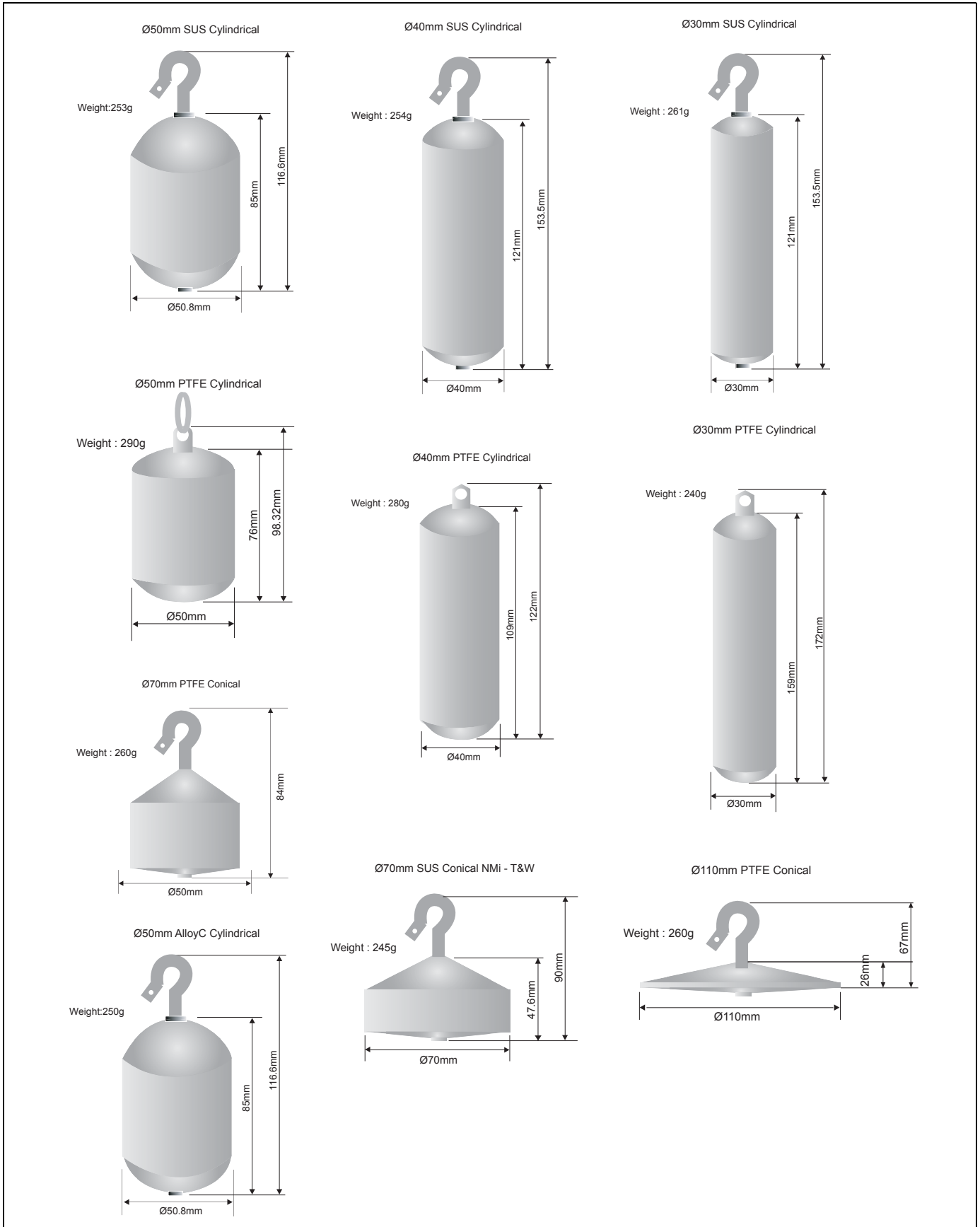









Declaration of contamination

Dear customer,

Because of legal determinations and for the safety of our employees and operating equipment, we need this "Declaration of contamination" with your signature before your order can be handled. Please, include the completely filled in declaration with the device and the shipping documents in any case. Add also safety sheets and / or specific handling instructions if necessary.

Type of device / sensor:	_____	Serial no.:	_____
Medium / concentration:	_____	Temperature:	_____ Pressure: _____
Cleaned with:	_____	Conductivity:	_____ Viscosity: _____

Warning hints for medium used (mark the appropriate hints)

							
<input type="checkbox"/>	<input type="checkbox"/>	<input type="checkbox"/>	<input type="checkbox"/>	<input type="checkbox"/>	<input type="checkbox"/>	<input type="checkbox"/>	<input type="checkbox"/>
radioactive	explosive	caustic	poisonous	harmful to health	biologically hazardous	inflammable	safe

Reason for return

Company data

Company:	_____	Contact person:	_____
	_____		_____
Address:	_____	Department:	_____
	_____	Phone:	_____
	_____	Fax / e-mail:	_____
		Your order no.:	_____

I hereby certify that the returned equipment has been cleaned and decontaminated acc. to good industrial practices and is in compliance with all regulations. This equipment poses no health or safety risks due to contamination.

(Place, date)

(Company stamp and legally binding signature)

WWW.endress.com/worldwide

Endress + Hauser Japan Co., Ltd.
Product Center Yamanashi
862-1 Mitsukunugi Sakaigawa-cho
Fuefuki-shi Yamanashi,
406-0846 Japan

Phone: ++81 55 266 4964
Fax: ++81 55 266 4969

Endress+Hauser 
People for Process Automation
