



Level



Pressure



Flow



Temperature



Liquid
Analysis



Registration



Systems
Components



Services



Solutions

Operating Instructions

Liquiline M CM42

Two-wire transmitter for pH measurement with digital IS-FET sensors

Part 2: Operation

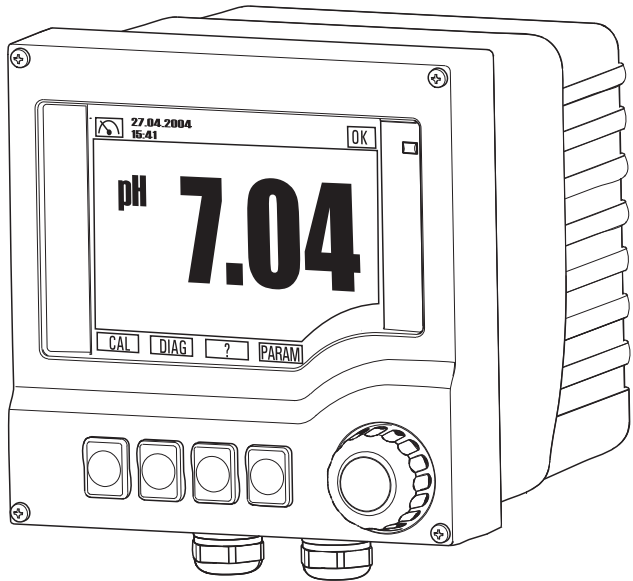

Operating concept

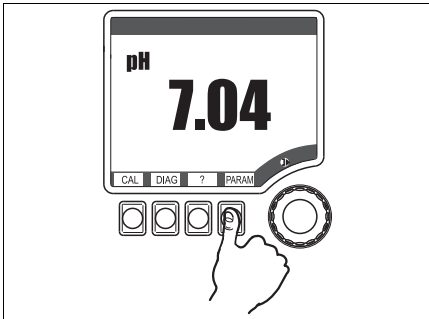

Fig. 1: Press soft key: select menu directly

a0005775

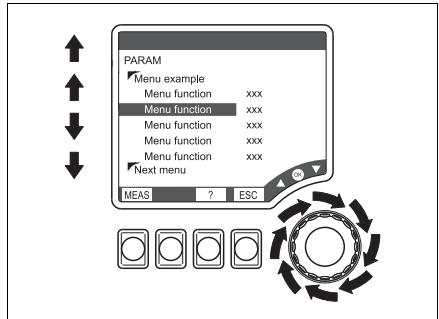

Fig. 2: Turn navigator: move cursor in the menu

a0005777-en

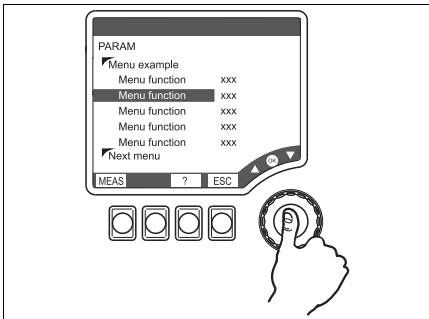

Fig. 3: Press navigator: select a function

a0005779-en

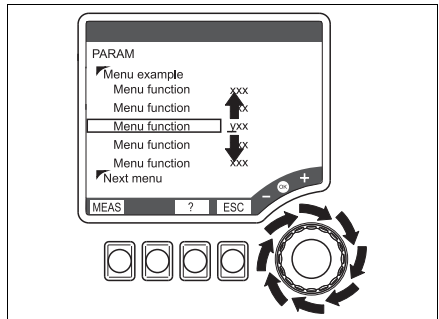

Fig. 4: Turn navigator: change value

a0005781-en

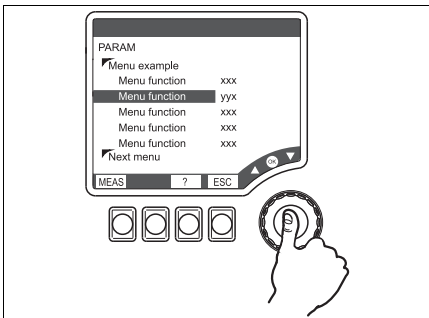

Fig. 5: Press navigator: accept new value

a0005783-en

Operating concept

1. You select a menu directly by pressing the soft key in question.
2. You move the cursor in the menu by turning the navigator.
3. Press the navigator and select the desired function.
4. Change the value by turning the navigator.
5. Press the navigator to accept the new value.

Table of contents

1	Display	4	7.7	Device-specific commands	38
1.1	Overview	4	7.8	Status messages	38
1.2	Status messages	4			
2	Notes on software description	5	8	Troubleshooting	40
2.1	Types of setting	5	8.1	Troubleshooting instructions	40
2.2	Editing tables	5	8.2	Diagnosis messages	40
2.3	User administration	5	8.3	Process errors without messages	44
			8.4	Software history	46
3	Measure (MEAS)	6			
4	Specifying the parameters (PARAM)	6		Index	48
4.1	Menu structure, top hierarchy level	6			
4.2	Sensor	6			
4.3	Current output	13			
4.4	General settings	14			
4.5	Display	18			
4.6	Quick Setup	19			
5	Device diagnosis (DIAG)	22			
5.1	Menu structure, top hierarchy level	22			
5.2	Errors/messages	22			
5.3	Change sensor	22			
5.4	Sensor status	23			
5.5	Output state	23			
5.6	Logbooks	23			
5.7	Sensor information	25			
5.8	Device information	26			
5.9	Service	27			
6	Calibration (CAL)	27			
6.1	Types of calibration	27			
6.2	Calibrate	28			
6.3	Calibration menu	28			
7	Communication	31			
7.1	HART Communicator	31			
7.2	Fieldcare	32			
7.3	Device identification	32			
7.4	Interfaces	33			
7.5	HART: Universal commands	34			
7.6	HART: Common practice commands	36			

1 Display

1.1 Overview

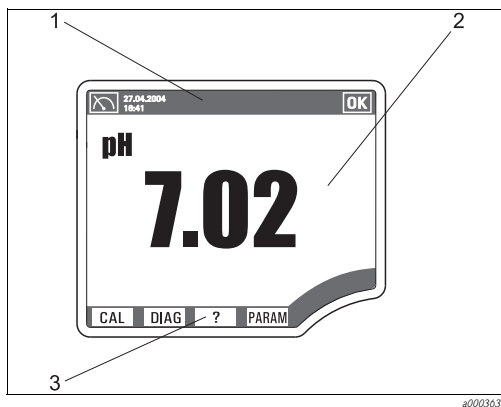

Fig. 6: Local display (measuring mode)

a0003031

- 1 Status line
- 2 Display and setting field
- 3 Assignment of the soft keys

1.2 Status messages

	Symbol for the measuring menu (MEAS)
	Device state is OK. No alarms or warnings are present.
	Service warning. Maintenance is recommended. The device is operational; the reliability of the measured value may be restricted.
	Alarm that points to an error. The device is no longer operational or the measured value is no longer reliable.
17.03.2009 16:59	Date and time display in measuring menu
I 7.68 pH II 5.23 pH	Measured value display in the status line if a menu other than MEAS is launched. The main values for channel 1 and channel 2 are displayed.
	Hold is set to "ON", the measured value is "frozen".
	Symbol for the simulation mode

2 Notes on software description

2.1 Types of setting

- Display fields
 - You can only read the values, not change them.
- Selection fields
 - You receive a list with options.
 - You select one of these options.
- Input fields
 - There are value ranges with upper and lower range limits that depend on the measured value configured and its units.
 - There are also menu functions where you can enter arbitrary text. The number of characters is then limited.
 - Set a value with the navigator:
 - Turn** to increase/reduce a value/letter/special character
 - Press** to confirm or to enter the next character for arbitrary text.

2.2 Editing tables

You can set some software functions using a table:

- The number of columns depends on the menu function that is set via the table.
- You can add lines ("Insert") or delete lines ("Del").
- The maximum number of lines also depends on the menu function in question.
- You can press "Esc" at any time to exit the table and stop entering information.
- If the values entered result in a valid table, you receive the message "Table is valid" and the options:
 - Save table
 - Continue edit table
 - Discard table
- If the values entered are invalid, an error message is output with the options:
 - Continue edit table
 - Discard table

2.3 User administration

As a "Specialist" you can assign user authorization for each individual software function.

Below, you will find the factory settings for the "Maintenance" user under "Configuration options" ("AC" column). The possible authorizations are as follows:

- R (=Read), only read access
- R/W (=Read+Write), Read and write access



Note!

The "Specialist" always has read and write access (R/W) and is, therefore, not listed.

3 Measure (MEAS)



Note!

In the measuring menu, you can switch between three different types of display. To do so, simply press the enter button of the navigator.

Function name of local operation (Display)

- Meas
 - Main value
 - pH
 - Main value and secondary value
 - pH
 - Temperature
 - All measured values
 - TAG name
 - Main value
 - Raw value
 - Temperature
 - ISFET leakage current
 - Current output 1
 - Current output 2

4 Specifying the parameters (PARAM)

4.1 Menu structure, top hierarchy level

- PARAM
 - Sensor pH
 - Current output
 - General settings
 - Display
 - Quick Setup

4.2 Sensor

4.2.1 Menu structure

Function name of display (local operation)

- PARAM
 - Sensor pH
 - Measured value
 - Damping

Function name of display (local operation)

- Cal. settings
 - Type of calibration
 - Temp. compensation
 - Medium temperature
(*Temp. compensation="Man.comp."*)
 - Buffer recognition
 - Buffer manufacturer
(*Buffer recognition="Automatic", "Set value"*)
 - Calib. buffer 1
(*Buffer recognition="Set value", "Manual"*)
 - Calib. buffer 2
(*Buffer recognition="Set value", "Manual"*)
 - Isotherm intersection
 - pH
 - Temp. adjustment
 - Mode
 - Offset
- Temp. compensation
- Medium temperature
(*Temp. compensation="Man.comp."*)
- Medium comp.
 - Type of compensation
 - Reference temperature
(*"Type of compensation"="2 point" or "Table"*)
 - Enter table
(*"Type of compensation"="Table"*)
 - Temperature 1
(*"Type of compensation"="2 point"*)
 - pH1
(*"Type of compensation"="2 point"*)
 - Temperature 2
(*"Type of compensation"="2 point"*)
 - pH2
(*"Type of compensation"="2 point"*)
- Sensor diagnosis
 - Diagnosis list
 - Diagnosis limits
 - Slope pH (1) (*only pH*)
 - Upper alarm value
 - Upper warning value
 - Operating pnt. (1)
 - Upper alarm value
 - Upper warning value
 - Lower warning value
 - Lower alarm value
 - Stabil. criteria

Function name of display (local operation)

- Bandwidth
 - Timeframe
- CAL timer
 - Function
 - Time
- PCS
 - Function
 - Time
- Operating hours
 - Operating time
 - Usage >80°C
 - Usage >100°C
 - Usage < -300mV
 - Usage >300mV
- Delta slope
- Delta operating point
- Cal. reminder
- Sterilisation cnt.

4.2.2 Configuration options

Function	Options	AC	Info
Measured value	No option selected	R	The sensor digitally transmits information on the sensor type to the transmitter. The measured value is thus automatically configured as a result. You can only change the measured value by connecting another sensor.
Damping	0 to 20 s Factory setting 0 s	R/W	The damping causes a floating average curve of the measured values over the time specified.
Cal. Settings			
Type of calibration	Options <ul style="list-style-type: none"> ■ 2 point cal. ■ Numeric input ■ 1-point cal. Factory setting 2 point cal.	R	
Temp. compensation	Options <ul style="list-style-type: none"> ■ Off ■ Auto comp. (ATC) ■ Man. comp. Factory setting Auto comp. (ATC)	R/W	 Note! This setting only refers to compensation during calibration, not in measuring mode.

Function	Options	AC	Info
Medium temperature	-50 to + 250 °C (-58 to + 482 °F) Factory setting 25 °C (77 °F)	R/W	Only for temp. compensation = "Man. comp."
Buffer recognition	Options <ul style="list-style-type: none"> ■ Automatic ■ Fixed ■ Manual Factory setting Fixed buffer	R/W	If you chose "Manual," you can specify any two buffers of your choice. These must differ in terms of their pH value.
Buffer manufacturer	Options <ul style="list-style-type: none"> ■ E+H (NIST) ■ Ingold/Mettler ■ DIN 19266 ■ DIN 19267 ■ Merck/Riedel Factory setting E+H (NIST)	R/W	Only for "Buffer recognition" = "Automatic" or "Set value" .
Calib. buffer 1	-2.0 to 16.0 pH Factory setting 6.98 pH	R/W	Only for "Buffer recognition" = "Manual" or "Set value" .
Calib. buffer 2	-2.0 to 16.0 pH Factory setting 4.01 pH	R/W	Only for "Buffer recognition" = "Manual" or "Set value" .
Isotherm intersection			
pH	-2.0 to 16.0 pH Factory setting 7.0 pH	R/W	
Temp. adjustment			
Mode	Options <ul style="list-style-type: none"> ■ 1-point Factory setting 1-point	R/W	1-point: You enter the temperature offset.
Offset	-5.0 to +5.0 °C (-23 to 41 °F) Factory setting 0.0 °C	R/W	Only if "Mode"="1-point" or 2-point (off-set/slope)"
Temp. compensation	Options <ul style="list-style-type: none"> ■ Off ■ Auto comp. (ATC) ■ Man. comp. Factory setting Auto comp. (ATC)	R	

Function	Options	AC	Info
Medium temperature	-50 to + 250 °C (-58 to + 482 °F) Factory setting 25 °C (77 °F)	R	Only for " Temp. compensation " = " Man. comp. "
Medium comp.		R/W	
Type of compensation	Options <ul style="list-style-type: none"> ■ Off ■ 2 point ■ Table Factory setting Off	R/W	
Reference temperature	-50 to 250 °C Factory setting 25 °C	R/W	Only if " Type of compensation " = " 2 point " or " Table "
Enter table	-50 to 250 °C Factory setting 25 °C	R/W	Only if " Type of compensation " = " Table " You specify the number of points and define the corresponding number of temperature and pH value pairs.
Temperature 1	-50 to 250 °C Factory setting 25 °C	R/W	Only if " Type of compensation " = " 2 point "
pH1	-2.00 to 16.00 Factory setting 7.00	R/W	Only if " Type of compensation " = " 2 point "
Temperature 2	-50 to 250 °C Factory setting 40 °C	R/W	Only if " Type of compensation " = " 2 point "
pH2	-2.00 to 16.00 Factory setting 7.50	R/W	Only if " Type of compensation " = " 2 point "
Sensor diagnosis			
Diagnosis list	Priority adjustable	R	You can change the priority of the errors by moving them up or down in the list.
Diagnosis limits			
Slope pH (1)	Selection and entry <ul style="list-style-type: none"> ■ Alarm value 5.00 to 99.99 mV/pH Factory setting 53.00 mV/pH ■ Maint. value 5.00 to 99.99 mV/pH Factory setting 55.00 mV/pH 	R	 Note! Set values affect the range of the corresponding variable (maint. value > alarm value).

Function	Options	AC	Info
Operating point (1)	Selection and entry <ul style="list-style-type: none"> ■ Upper alarm value Factory setting 300 mV ■ Upper warning value Factory setting 250 mV ■ Lower warning value Factory setting -250 mV ■ Lower alarm value Factory setting -300 mV General range of adjustment -2000 to 2000 mV	R	
Stabil. criteria	Selection and entry <ul style="list-style-type: none"> ■ Bandwidth 1 to 10 mV Factory setting 1 mV ■ Timeframe 5 to 60 s Factory setting 20 s 	R	Preselection for CAL: With the bandwidth, you define the permitted measured value fluctuation which must not be exceeded in a certain timeframe during calibration. Calibration is not permitted if the permitted difference is exceeded. In this case, calibration is aborted with an error after maximum 600 seconds.
CAL timer	Selection and entry <ul style="list-style-type: none"> ■ Function on/off ■ Time 1 to 9999 h Factory setting Off	R/W	
PCS	Selection and entry <ul style="list-style-type: none"> ■ Function on/off ■ Time 1 to 240 min Factory setting Off	R/W	With PCS (Process Check System), the measuring signal is checked for stagnation. An alarm is triggered if the measuring signal does not change over a certain period (several measured values). The reason for such behavior could be fouling, clogging or similar. → CD-ROM
Operating hours	In the following menus, you define a warning value and an alarm value for using your sensor under extreme conditions. General range of adjustment is: 1 to 9999 h. The factory settings are marked in bold.		
Operating time	<ul style="list-style-type: none"> ■ Warning value 8000h ■ Alarm value 8800h 	R/W	

Function	Options	AC	Info
Usage >80°C	<ul style="list-style-type: none"> ■ Warning value 1800h ■ Alarm value 2000h 	R/W	
Usage >100°C	<ul style="list-style-type: none"> ■ Warning value 450h ■ Alarm value 500h 	R/W	
Usage < -300mV			
Usage >300mV			
Delta slope	<ul style="list-style-type: none"> ■ Function Factory setting Off ■ Warning value Factory setting 3 mV/pH ■ Alarm value Factory setting 5 mV/pH <p>General range of adjustment 0.00 to 9.99 mV/pH</p>	R	
Delta operating point	<p>Selection and entry</p> <ul style="list-style-type: none"> ■ Function Factory setting Off ■ Warning value Factory setting 10 mV ■ Alarm value Factory setting 15 mV <p>General range of adjustment -200 to +200 mV</p>	R	
Cal. reminder	<p>Selection and entry</p> <ul style="list-style-type: none"> ■ Warning value Factory setting 5 months ■ Alarm value Factory setting 8 months <p>General range of adjustment 0 to 24 months</p>	R	

Function	Options	AC	Info
Sterilisation cnt.	Selection and entry ■ Warning value Factory setting 20 ■ Alarm value Factory setting 30 General range of adjustment 1 to 99	R	

4.3 Current output

4.3.1 Menu structure

Function name of display (local operation)

- ▢ PARAM
 - ▢ Current output
 - ▢ Current output 1
 - ▢ Output source
 - ▢ Low value (4mA)
 - ▢ Upper value (20mA)
 - ▢ Current output 2
 - ▢ Output source
 - ▢ Low value (4mA)
 - ▢ Upper value (20mA)
 - ▢ Enter table

4.3.2 Configuration options

Function	Options	AC	Info
Current output 1			
Output source	Options ■ Main value Factory setting Main value	R/W	







Function	Options	AC	Info
Low value (4mA)	-2 to (20 mA value) - 1 pH Factory setting 2 pH	R/W	Specify the measured value that should correspond to the 4 mA or 20 mA value. The smallest possible spread between 4 mA and 20 mA value is: 1 pH
Upper value (20mA)	(4 mA value) + 1 pH to 16 pH Factory setting 12 pH	R/W	
Current output 2			
Output source	Options ■ Main value ■ Temperature Factory setting Temperature	R/W	
Low value (4mA)	-50 to (20 mA value) - 5 °C Factory setting -20 °C	R/W	The smallest possible spread between 4 mA and 20 mA value is 1 °C.
Upper value (20mA)	(4 mA value) + 5 °C to 250 °C Factory setting +100 °C	R/W	

4.4 General settings

4.4.1 Menu structure

Function name of display (local operation)

PARAM

-  General settings
 -  TAG number
 -  Date format
 -  Set date
 -  Time format
 -  Set time



Function name of display (local operation)

- Alarm message
 - Alarm active
 - Alarm value (*Alarm active="Set value"*)
 - Maintenance message
 - Maintenance active
 - Maint. value (*Maintenance active="Set value"*)
 - Hold settings
 - Calib active
 - Calib value (*calib. active = "Set value"*)
 - Param active
 - Param value (*param. active = "Set value"*)
 - Diag active
 - Diag. value (*diag. active="Set value"*)
 - Hold delay
 - Device diagnosis
 - Diagnosis list
 - User admin.
 - Log in
 - (*not if "Specialist" is already logged on*)
 - Password protection
 - Enter code
 - (*only if you are logged on as a "Specialist"*)
 - Specialist
 - Maintenance
 - Lab device
 - Sensorcheck
 - TAG group (*sensorcheck="TAG group"*)
 - TAG number (*sensorcheck="TAG"*)
 - Bus address

4.4.2 Configuration options

Function	Options	AC	Info
TAG number	Can be edited at random	R/W	Max. 20 characters
Date format	Options <ul style="list-style-type: none"> ■ DD.MM.YYYY ■ MM.DD.YYYY Factory setting DD.MM.YYYY	R/W	Editing mode: DD (day): 1 to 31 MM (month): 1 to 12 YYYY (year): 2005 to 2100
Set date	Depends on the format DD.MM.YYYY	R/W	

Function	Options	AC	Info
Time format	Options <ul style="list-style-type: none"> ■ hhmmss (24 h) ■ hhmmss (am / pm) Factory setting hhmmss (24 h)	R/W	24-hour display or 12-hour display Editing mode: hh (hour): 0 to 23 / 0 am to 12 pm mm (minutes): 0 to 59 ss (seconds): 0 to 59
Set time	Depends on the format hh:mm:ss	R/W	
Alarms			
Alarm message			
Alarm active	Options <ul style="list-style-type: none"> ■ Off ■ Freeze (I1) ■ Set value (I1) Factory setting Set value (I1)	R	
Alarm value	20.5 to 22 mA Factory setting 22 mA	R	Only if Alarm active="Set value (I1)"
Maintenance message			
Maintenance active	Options <ul style="list-style-type: none"> ■ Off ■ Freeze (I2) ■ Set value (I2) Factory setting Off	R	
Maint. value	20.5 to 22 mA Factory setting 22 mA	R	Only if Maintenance active="Set value (I2)"
Hold settings			
Calib active	Options <ul style="list-style-type: none"> ■ No hold ■ Freeze ■ Fixed Factory setting No hold	R	<ul style="list-style-type: none"> ■ Freeze: Device keeps the last measured value. ■ Set value: You define a set display value.
Calib value	20.5 to 22 mA Factory setting 21.5 mA	R	Only if Calib active="Set value"
Param active	Options <ul style="list-style-type: none"> ■ No hold ■ Freeze ■ Fixed Factory setting No hold	R	<ul style="list-style-type: none"> ■ Freeze: Device keeps the last measured value. ■ Set value: You define a set display value.

Function	Options	AC	Info
Param value	20.5 to 22 mA Factory setting 21.5 mA	R	Only if Param active="Set value"
Diag active	Options <ul style="list-style-type: none"> ■ No hold ■ Freeze ■ Fixed Factory setting No hold	R	<ul style="list-style-type: none"> ■ Freeze: Device keeps the last measured value. ■ Set value: You define a set display value.
Diag. value	20.5 to 22 mA Factory setting 21.5 mA	R	Only if Diag active="Set value"
Hold delay	0 to 60 s Factory setting 5 s	R	
Device diagnosis			
Diagnosis list	For all messages, you can assign a customer-specific status (alarm/warning/info), see Section "Troubleshooting"/"Diagnosis messages".		
User admin.			
Log in	Options <ul style="list-style-type: none"> ■ Specialist ■ Maintenance Factory setting Maintenance	R	Once the user is selected, you are prompted to enter a code of your choice. Factory setting is empty.  Note! More information is provided on the user roles under "Commissioning" in the first part of the Operating Instructions.
Password protection	Options <ul style="list-style-type: none"> ■ None ■ Enter code Factory setting None	R/W	 Caution! The "Enter code" option is only visible if you are logged on as a "Specialist"!
Enter code	Here, you can enter a code for the user roles "Specialist" and "Maintenance" (you have to be logged on as a "Specialist"!).		
Specialist	Options <ul style="list-style-type: none"> ■ Password Factory setting Empty (nothing entered) ■ Store 		Once you have specified a password of your choice, go to Store (= Enter). The message "Stored new password" and "OK" is displayed.
Maintenance			
Lab device	Options <ul style="list-style-type: none"> ■ Off ■ On Factory setting Off	R	Use "On" to define the device as a lab device. In this way, you can connect the device to Memobase and the information that has been saved in the sensor on the last measuring point (TAG, TAG group) is not overwritten.

Function	Options	AC	Info
Sensorcheck	Options <ul style="list-style-type: none"> ■ Off ■ TAG group ■ TAG Factory setting Off	R	Use this setting to specify what sensors are accepted at your device: <ul style="list-style-type: none"> ■ Off: All sensors are accepted. ■ TAG group: The device only accepts sensors from a group of equivalent measuring points and brand-new sensors fresh from the factory with the exact same order code as the sensor which was the forerunner. ■ TAG: The device only accepts sensors from a specific measuring point and brand-new sensors fresh from the factory with the exact same order code as the sensor which was the forerunner. Connecting a sensor that is not accepted triggers an alarm.
TAG group	1 to 10000 Factory setting 1	R	Only if sensorcheck="TAG group"
TAG number	Can be edited at random Factory setting STANDARD	R	Only if sensorcheck="TAG"
Bus address	Entry <ul style="list-style-type: none"> ■ 0 to 15 Factory setting 0	R	

4.5 Display

4.5.1 Menu structure

Function name of display (local operation)

PARAM

Display

- Language
- Main value format
- Temperature unit
- Temperature format











4.5.2 Configuration options

Function	Options	AC	Info
Language	Options <ul style="list-style-type: none"> ■ English ■ Language ordered Factory setting Language ordered	R/W	 Note! "Language ordered" refers to the language that you selected for your device using the order code ("device language"). If you select the other language in question, all the other settings remain intact.
Main value format	Options <ul style="list-style-type: none"> ■ x.x ■ x.xx Factory setting x.xx	R/W	You select how many commas should appear after the decimal point in the measured value display.
Temperature unit	Options <ul style="list-style-type: none"> ■ °C ■ °F Factory setting °C	R/W	
Temperature format	Options <ul style="list-style-type: none"> ■ xxx ■ xxx.x Factory setting xxx.x	R/W	You select how many commas should appear after the decimal point in the temperature display.









4.6 Quick Setup

4.6.1 Menu structure

Function name of display (local operation)

-  PARAM
 -  Quick Setup
 -  Language
 -  Date format
 -  Set date
 -  Time format
 -  Set time
 -  Temperature unit
 -  Buffer manufacturer
 -  Temp. compensation

Function name of display (local operation)

-  Medium temperature
(Temp. compensation="Man. comp.")
-  Current output 1
 -  Output source
 -  Low value (4mA)
 -  Upper value (20mA)
-  Current output 2
 -  Output source
 -  Low value (4mA)
 -  Upper value (20mA)

4.6.2 Configuration options

Function	Options	AC	Info
Language	Options <ul style="list-style-type: none"> ■ English ■ Language ordered Factory setting Language ordered	R/W	 Note! "Language ordered" refers to the language that you selected for your device using the order code ("device language"). If you select the other language in question, all the other settings remain intact.
Date format	Options <ul style="list-style-type: none"> ■ DD.MM.YYYY ■ MM.DD.YYYY Factory setting DD.MM.YYYY	R/W	Editing mode: DD (day): 1 to 31 MM (month): 1 to 12 YYYY (year): 2005 to 2100
Set date	Depends on the format DD.MM.YYYY	R/W	
Time format	Options <ul style="list-style-type: none"> ■ hhmmss (24 h) ■ hhmmss (am / pm) Factory setting hhmmss (24 h)	R/W	24-hour display or 12-hour display Editing mode: hh (hour): 0 to 23 / 0 am to 12 pm mm (minutes): 0 to 59 ss (seconds): 0 to 59
Set time	Depends on the format hh:mm:ss	R/W	
Temperature unit	Options <ul style="list-style-type: none"> ■ °C ■ °F Factory setting °C	R/W	

Function	Options	AC	Info
Buffer manufacturer	Options <ul style="list-style-type: none"> ■ E+H (NIST) ■ Ingold/Mettler ■ DIN 19267 ■ DIN 19266 ■ Merck/Riedel Factory setting E+H (NIST)	R/W	
Temp. compensation	Options <ul style="list-style-type: none"> ■ Off ■ Auto comp. (ATC) ■ Man. comp. Factory setting Auto comp. (ATC)	R/W	
Medium temperature	-50 to + 250 °C (-58 to + 482 °F) Factory setting 25 °C (77 °F)	R/W	Only for temp. compensation = "Man. comp."
Current output 1			Main value
Output source	Options <ul style="list-style-type: none"> ■ Main value Factory setting Main value	R	
Low value (4mA)	-2 to (20 mA value) - 1 pH Factory setting 2 pH	R/W	Specify the measured value that should correspond to the 4 mA or 20 mA value. The smallest possible spread between 4 mA and 20 mA value is: 1 pH
Upper value (20mA)	(4 mA value) + 1 pH to 16 pH Factory setting 12 pH	R/W	
Current output 2			Temperature
Output source	Options <ul style="list-style-type: none"> ■ Main value ■ Temperature Factory setting Temperature	R	
Low value (4mA)	-50 to (20 mA value) - 5 °C Factory setting -20 °C	R/W	The smallest possible spread between 4 mA and 20 mA value is 0.1 °C.
Upper value (20mA)	(4 mA value) + 5 °C to 250 °C Factory setting +100 °C	R/W	

5 Device diagnosis (DIAG)











Note!

In the DIAG menu you will find information about the device state, in particular detailed error and maintenance messages.

In addition to this, there are various service functions available¹⁾.

Furthermore, you can configure your optional recorder in the "Datalogger" submenu.

5.1 Menu structure, top hierarchy level

-  DIAG
 -  Errors/messages
 -  Change sensor
 -  Sensor state
 -  Output state
 -  Logbooks
 -  Sensor information
 -  Device information
 -  Service





5.2 Errors/messages

Function name of display (local operation)

-  DIAG
 -  Errors/messages

5.3 Change sensor

Function name of display (local operation)

-  DIAG
 -  Change sensor
 -  Start sensorchange
 -  Abort sensorchange

1. Select "Start sensorchange".
2. The message "Please change sensor" is displayed.
Depending on whether you assigned, or did not assign, a TAG number or TAG group in the "PARAM/General settings/Sensorcheck" menu, you also receive information on the sensor expected by the device.

1) Depending on the device version

3. Change the sensor. Make sure that the new sensor belongs to the requisite TAG or TAG group.
Once you have connected the new sensor, the message "Initializing sensor" is displayed and afterwards the message "Sensor has valid tag" (or TAG group).
You can now choose whether you want to use the sensor or repeat the sensor change routine. You can also display the sensor data.
4. If you have connected a sensor with an invalid TAG or TAG group, an appropriate message is displayed. The device will not accept this sensor. You can now repeat the sensor change routine with a valid sensor or you can view the sensor data of the (invalid) sensor.
5. Please follow the instructions on the display.

5.4 Sensor status

Function name of display (local operation)

- DIAG
 - Sensor state

5.5 Output state

Function name of display (local operation)

- DIAG
 - Output state
 - Current settings for:**
 - Current output 1
 - Output source
 - Current output 2
 - Output source
 - Output range







5.6 Logbooks

5.6.1 Menu structure

Function name of display (local operation)

- DIAG
 - Logbooks
 - Recording
 - Calibration logbook
 - Event logbook
 - User logbook
 - Version logbook
 - Hardware logbook

Function name of display (local operation)









































-  Data logbook
 -  Recording
 -  Sample time
 -  Measured value
 -  Show data
-  Delete entries

5.6.2 Configuration options

Function	Options	AC	Info
Recording	Options <ul style="list-style-type: none"> ■ On ■ Off Factory setting Off	R/W	Activate or deactivate logbook recording. Exception: data logbook. You can activate/deactivate this in its own submenu.
Calibration logbook		R	Log of calibrations and adjustments
Event logbook		R	Log of the warnings and error messages
User logbook		R	Log of logins and logouts
Version logbook		R	Log of the firmware versions
Hardware logbook		R	Log of the installed hardware modules
Data logbook		R	Cyclic recording of measured values
Recording	Options <ul style="list-style-type: none"> ■ On ■ Off Factory setting Off	R/W	
Sample time	0 h 0 min 2 s to 99 h 59 min 59 s Factory setting 0 h 0 min 2 s	R/W	Here you can specify the intervals in which measured values are recorded.
Measured value	Options <ul style="list-style-type: none"> ■ Raw value ■ Temperature ■ Main value Factory setting Raw value	R/W	Define the measured value that should be recorded.
Show data		R	Log of the measured values
Delete entries		R	This function deletes all the logbook entries.

5.7 Sensor information

Function name of display (local operation)

-  DIAG
 -  Sensor information
 -  Memosens data
 -  Identification
 -  Hardware identifier
 -  Serial number
 -  Order code
 -  Hardware version
 -  Software version
 -  TAG
 -  TAG group
 -  Type of calibration
 -  <Type of calibration> (last used)
 -  Slope
 -  Operating point
 -  Isotherm intersection pH
 -  Date of calibration
 -  Time of calibration
 -  Calib. buffer 1
 -  Calib. buffer 2
 -  Number of cal.
 -  Delta slope
 -  Delta operating point
 -  SN transmitter
(= with which the last calibration was)
 -  Temp. Calibration
 -  Temperature offset
 -  Temp. cal. date
 -  Temp. cal. time
 -  Operating hours
 -  Operating time
 -  Number of sterilizations
 -  Max. temperature
 -  Usage >80°C
 -  Usage >100°C
 -  Usage >300 mV
 -  Usage < -300 mV
 -  Commissioning date
 -  Specification
 -  Min. pH
 -  Max. pH
 -  Min. temperature

Function name of display (local operation)

- Max. temperature

5.8 Device information

Function name of display (local operation)

■ DIAG

■ Device information

- TAG number
- Hardware identifier
- Order code
- Serial number
- Software version
- Bus address

■ CPU

- Hardware identifier
- Serial number
- Part number
- Hardware version
- Bootloader version

■ Sensor module















- Hardware identifier
- Serial number
- Part number
- Hardware version
- Firmware version

■ Fieldbus module

- Hardware identifier
- Serial number
- Part number
- Hardware version
- Firmware version

5.9 Service

Function name of display (local operation)

-  DIAG
 -  Service
 -  Simulation
 -  Current output 1
 -  Simulation
 -  Simulation value
 -  Current output 2
 -  Simulation
 -  Simulation value
 -  Reset
 -  Confirmation: Abort action
 -  Confirmation: Reset
 -  Factory default
 -  Confirmation: Abort action
 -  Confirmation: Factory default



Note!

The "Reset" option causes the device to be restarted while maintaining the settings made. If "Factory default" is selected, the device is reset and all the settings are reset to the factory settings.

6 Calibration (CAL)

Calibration is necessary:

- After periods of standstill
- At sensible, process-dependent intervals²⁾



Note!

To achieve reproducible measuring results, we recommend you use quality buffers from Endress+Hauser.

6.1 Types of calibration

- Two-point calibration
 - With automatic buffer recognition:
 - You select the buffer type (e.g. DIN 19266). The device automatically recognizes the buffer during calibration.
 - With fixed buffer:

2) Depending on the process conditions, the intervals can range from several times daily to once quarterly.

You select two buffer solutions from the menu.

- Single-point calibration
 - You enter an offset.
- Numeric input:
 - You enter the slope, zeropoint and temperature.
- Grab sample calibration
 - You take a sample of the medium. The device determines a measured value while you analyze the sample in the laboratory. Then you enter the laboratory measured value. The device calibrates on the basis of the laboratory value.

6.2 Calibrate

Proceed as follows to calibrate the sensor:

1. Remove the sensor from the process.
2. Clean the sensor.
3. Press the soft key for "CAL".
4. Follow the instructions in the menu.
5. Finish calibrating by switching back to the measuring mode.
6. Install the sensor back into the process.

Your measuring point is now ready for operation.



Note!

- If calibration is aborted using ESC, or if the calibration is faulty, the system continues to use the original calibration data. A calibration error is shown as plain text on the display.
- Any offset set is automatically deleted after accepting the calibration.

6.3 Calibration menu

6.3.1 Menu structure

- CAL
 - Numeric input
 - Slope
 - Op. point
 - Enter new values
 - Slope
 - Op. point
 - Temperature
 - Continue
 - Store data for adjustment/discard data
 - 2 point cal.

Function	Options	Action
Enter new values		<ol style="list-style-type: none"> 1. You enter the calibration values manually in succession. The values are displayed in a table. 2. Once you press "Continue" you are asked whether you wish to store or discard the values. 3. Depending on what you select, an appropriate message appears on the display.
Slope	5.0 to 99.0 mV/pH	
Op. point	-2.0 to 16.0 pH	
Temperature	-50 to +250 °C (-58 to +482 °F)	
Store data for adjustment/discard data		
2 point cal.		
Please enter temperature value.	-50 to +250 °C (-58 to +482 °F)	<ol style="list-style-type: none"> 1. Enter the current temperature (only if you selected "Temp. compensation" = "Man. input (MTC)" under Cal. Settings). 2. Immerse the sensor into buffer 1 and start the calibration. ("Calibration running" message) 3. Remove the sensor from buffer 1 and rinse it with water. 4. Immerse the sensor into buffer 2 and start the calibration again. ("Calibration running" message) 5. Accept the calibration, calibrate again or abort the calibration.
Set point buffer 1	->Cal. settings	
Put electrode into buffer 1		
Start calibration		
Set point buffer 2		
Like buffer 1		
Put electrode into buffer 1		
Start calibration		
Calibration valid/calibration invalid		
Store data for adjustment/discard data (only if "Calibration valid")		
Offset		
Please enter the offset	-2.0 to 16.0 pH	<ol style="list-style-type: none"> 1. Enter an offset. 2. Select "Continue".
Store data for adjustment/discard data		
Grab sample cal.		
Grab sample for calibration		<ol style="list-style-type: none"> 1. Take a sample of the medium. 2. Press "Store data for adjustment". Liquiline changes to the "Measure" mode and "Grab sample cal. running" is shown on the display. 3. Determine the pH value of your sample in the laboratory.¹⁾ 4. Press the "CAL" key. 5. Enter the laboratory value. 6. Select "Continue".
Accept current meas values		
Laboratory meas value	-2.0 to 16.0 pH	
Store data for adjustment/discard data		
Temp. adjustment		

Function	Options	Action
Mode	Options ■ 1-point	
Offset	Display the current value	
Start adjustment		1. Start adjustment ("Waiting for stable temperature" message). 2. Enter the reference temperature and confirm with "OK". 3. The new offset is calculated.
Enter ref. temperature 1	-49.0 to +250.0 °C	
New offset	Display the calculated value	
Store data for adjustment/discard data		

- 1) Temper the sample during laboratory measurement to the display value at the time of sampling. Carry out the comparison measurement as fast as possible as the pH can be falsified by volatile substances escaping.

7 Communication

Parameter entry and measured value interrogation take place by means of HART® protocol. When doing so, digital communication is performed via the 4 to 20 mA current output.

You have the following options for parameter entry:

- Operation via the universal handheld terminal Communicator DXR375
- Operation via PC using Endress+Hauser operating software, e.g. "Fieldcare", and a HART® modem



Note!

Detailed information about HART communication can be found in the document CM42PH-LIT-18.pdf (English) on the CD-ROM.

7.1 HART Communicator

If a Liquiline DD (Device Description) is installed on your Communicator, you can make all settings via the Communicator.

Only restricted configuration or operation is possible with a (pre-installed) universal DD.

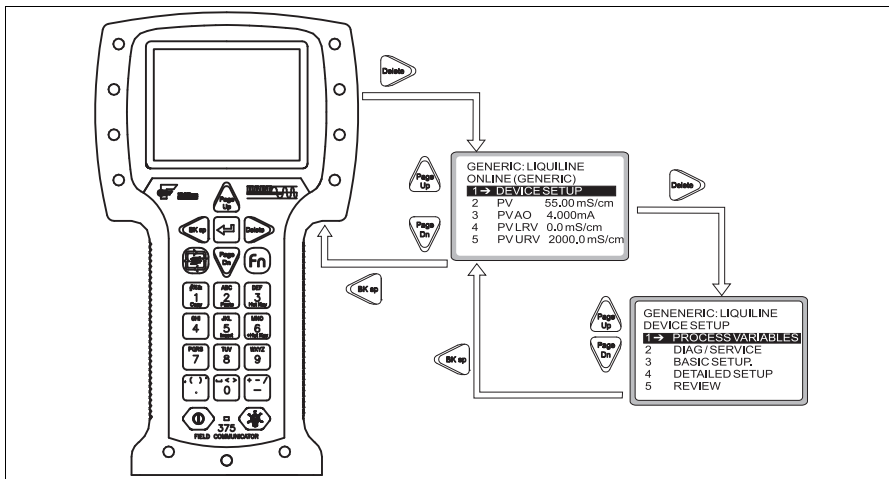

Fig. 7: Operation of the handheld terminal

40005134



Note!

For information about how to operate the handheld terminal, please refer to the Operating Instructions enclosed with the handheld terminal.

7.2 Fieldcare

"Fieldcare" is a universally applicable service and communication software based on FDT/DTM technology.

The DTMs available for the device can also be used with software from other manufacturers that supports FDT/DTM technology.



Note!

Further information can be found in the Installation Instructions from "Fieldcare" supplied with the software, or on our homepage.

7.3 Device identification

Manufacturer name:	Endress+Hauser
Model name:	Liquiline M CM42
Manufacturer ID code:	17 (11 _h)
Device type code:	143 (8F _h)
HART protocol revision:	5.2
Device revision:	10 (0A _h)
Number of device variables:	5
Physical layers supported:	FSK

Physical device category: Transmitter, non-DC-isolated bus device

7.4 Interfaces

Analog output 1: Main value

The main value corresponds to the HART primary variable.
HART communication is **only available at this output** .

Analog output 2

No HART communication is available via this output.

Multidrop mode

If you want to operate Liquiline in the Multidrop mode, you have to turn the Multidrop rotary switch at the CPU module (→  8, 45 ° counterclockwise).

In Multidrop mode, the current output is fixed at 4.2 mA right from when the device is started.
This allows you achieve the best Multidrop compatibility.

In contrast, Liquiline starts normal operation with 22.5 mA to guarantee SIL conformity.

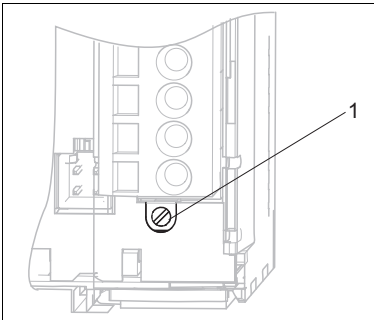

Fig. 8: CPU module (extract)





1 Multidrop screw





Note!

The diagram displays the Multidrop rotary switch in the "Off" position=no Multidrop.



7.5 HART: Universal commands

No. ¹)	HART command/ Access type	Command data ¹⁾	Response data ¹⁾
0	Unique device identifier Access type ■ Read	None	Information on device and manufacturer (12 byte): <ul style="list-style-type: none"> ■ Byte 0: fixed value 254 ■ Byte 1: manufacturer ID 17 (= Endress+Hauser) ■ Byte 3: number of preambles ■ Byte 4: rev. no. universal commands ■ Byte 5: rev. no. device-specific commands ■ Byte 6: software revision ■ Byte 7: hardware revision ■ Byte 8: additional device information ■ Byte 9-11: device identification
1	Main value Access type ■ Read	None	<ul style="list-style-type: none"> ■ Byte 0: HART unit ID of main value ■ Byte 1-4: main value
2	Main value in mA and % of measuring range Access type ■ Read	None	<ul style="list-style-type: none"> ■ Byte 0-3: actual current [mA] at current output 1 ■ Byte 4-7: % of configured measuring range
3	Main value in mA and 4 dynamic process variables Access type ■ Read	None	24-byte response: <ul style="list-style-type: none"> ■ Byte 0-3: value of current output 1 (main value in mA) ■ Byte 4: HART unit ID of main value ■ Byte 5-8: main value ■ Byte 9: HART unit ID of secondary process variable ■ Byte 10-13: secondary process variable ■ Byte 14: HART unit ID of third process variable ■ Byte 15-18: third process variable ■ Byte 19: HART unit ID of fourth process variable ■ Byte 20-23: fourth process variable <p>Factory setting</p> <ul style="list-style-type: none"> ■ Secondary process variable = temperature
6	HART short-form address Access type ■ Write	<ul style="list-style-type: none"> ■ Byte 0: desired address <p>Fact. setting</p> <ul style="list-style-type: none"> ■ 0 	<ul style="list-style-type: none"> ■ Byte 0: active address <p> Note! If an address >0 (Multidrop mode), current output 1 is permanently set to 4 mA. Any simulation running is terminated. The device boots again with 22 mA. It can be booted with 4 mA by adjusting the Multidrop switch.</p>
11	Unique device identifier using the tag name Access type ■ Read	Byte 0-5: tag name  Note! Setting with command 18	The response consists of a 12-byte ID if the tag name specified matches that of the device.  Note! Settings as for command 0, see above.
12	User message Access type ■ Read	None	<ul style="list-style-type: none"> ■ Byte 0-23: current user message <p> Note! Write message → command 17</p>

No. ¹)	HART command/ Access type	Command data ¹⁾	Response data ¹⁾
13	Tag name, description and date Access type ■ Read	None	<ul style="list-style-type: none"> ■ Byte 0-5: tag name ■ Byte 6-17: tag description ■ Byte 18-20: date <p> Note! Write values → command 18</p>
14	Sensor info main value Access type ■ Read	None	<ul style="list-style-type: none"> ■ Byte 0-2: sensor serial number ■ Byte 3: unit ID, sensor limits and measuring range of main value ■ Byte 4-7: upper sensor limit ■ Byte 8-11: lower sensor limit ■ Byte 12-15: minimum distance from limits
15	Output info, main value Access type ■ Read	None	<ul style="list-style-type: none"> ■ Byte 0: alarm selection ID ■ Byte 1: ID for transmission function ■ Byte 2: unit ID, main value measuring range ■ Byte 3-6: end of measuring range (20 mA value) ■ Byte 7-10: start of measuring range (4 mA value) ■ Byte 11-14: damping in s ■ Byte 15: ID for write protection ■ Byte 16: ID of OEM dealer (17 = Endress+Hauser)
16	Production number Access type ■ Read	None	<ul style="list-style-type: none"> ■ Byte 0-2: production number <p> Note! Write production number → command 19</p>
17	User message Access type ■ Write	Byte 0-23: desired message (max. 32 characters)	<ul style="list-style-type: none"> ■ Byte 0-23: current message
18	Tag name, description and date Access type ■ Write	<ul style="list-style-type: none"> ■ Tag (8 characters) ■ Tag description (16 characters) ■ Date 	<ul style="list-style-type: none"> ■ Byte 0-5: tag name ■ Byte 6-17: tag description ■ Byte 18-20: date
19	Production number Access type ■ Write	Enter a number ranging from 0 to 1677715	<ul style="list-style-type: none"> ■ Byte 0-2: production number

1) Numbers in decimal notation

7.6 HART: Common practice commands

No.	HART command/ Access type	Command data ¹⁾	Response data ¹⁾
33	Device Variables Access type ■ Read	<ul style="list-style-type: none"> ■ Byte 0: Device Variable 1 Code ■ Byte 1: Device Variable 2 Code ■ Byte 2: Device Variable 3 Code ■ Byte 3: Device Variable 4 Code 	<ul style="list-style-type: none"> ■ Byte 0: Device Variable 1 Code ■ Byte 1: Device Variable 1 Unit ■ Byte 2-5: Value of Device Variables 1 ■ Byte 6: Device Variable 2 Code ■ Byte 7: Device Variable 2 Unit ■ Byte 8-11: Value of Device Variables 2 ■ Byte 12: Device Variable 3 Code ■ Byte 13: Device Variable 3 Unit ■ Byte 14-17: Value of Device Variables 3 ■ Byte 18: Device Variable 4 Code ■ Byte 19: Device Variable 4 Unit ■ Byte 20-23: Value of Device Variables 4
34	Damping main value Access type ■ Write	<ul style="list-style-type: none"> ■ Byte 0-3: damping in s 	<ul style="list-style-type: none"> ■ Byte 0-3: damping in s
35	Main value measuring range Access type ■ Write	<ul style="list-style-type: none"> ■ Byte 0: unit ID ■ Byte 1-4: end of measuring range ■ Byte 5-8: start of measuring range 	<ul style="list-style-type: none"> ■ Byte 0: unit ID ■ Byte 1-4: end of measuring range (20 mA value) ■ Byte 5-8: start of measuring range (4 mA value)
36	Adopt measured value as scaling upper limit Access type ■ Write	None	None
37	Adopt measured value as scaling lower limit Access type ■ Write	None	None
38	Reset status "Parameter change" (config changed) Access type ■ Write	None	None
40	Current output simulation, main value Access type ■ Read	<ul style="list-style-type: none"> ■ Byte 0-3: output current in mA <p> Note!</p> <ul style="list-style-type: none"> ■ You can simulate values between 2 and 22 mA. ■ You exit simulation by entering 0. ■ Simulation is not possible in Multidrop mode. 	<ul style="list-style-type: none"> ■ Byte 0-3: output current in mA
41	Start selftest Access type ■ Read	None	None
42	Device reset Access type ■ Write	<p>None</p> <p> Note!</p> <p>Communication is not possible during initialization due to the reset.</p>	None

No.	HART command/ Access type	Command data ¹⁾	Response data ¹⁾
44	Main value unit Access type ■ Write	<ul style="list-style-type: none"> ■ Byte 0: unit ID None  Note! Only units that suit the main value are accepted.	<ul style="list-style-type: none"> ■ Byte 0: unit ID None
45	Calibrate the current output lower limit (only possible in 4 mA simulation) Access type ■ Write	<ul style="list-style-type: none"> ■ Byte 0-3: externally measured current value 	<ul style="list-style-type: none"> ■ Byte 0-3: measured current value
46	Calibrate the current output upper limit (only possible in 20 mA simulation) Access type ■ Write	<ul style="list-style-type: none"> ■ Byte 0-3: externally measured current value 	<ul style="list-style-type: none"> ■ Byte 0-3: measured current value
48	Extended device status Access type ■ Read	None	See Section "Troubleshooting"/"Diagnosis messages"
50	Assignment of the dynamic process variables Access type ■ Read	None	<ul style="list-style-type: none"> ■ Byte 0: Device Variables Code for dynamic process variable 1 ■ Byte 1: Device Variables Code for dynamic process variable 2 ■ Byte 2: Device Variables Code for dynamic process variable 3 ■ Byte 3: Device Variables Code for dynamic process variable 4
51	Assignment of the dynamic process variables Access type ■ Write	<ul style="list-style-type: none"> ■ Byte 0: Device Variables Code for dynamic process variable 1 ■ Byte 1: Device Variables Code for dynamic process variable 2 ■ Byte 2: Device Variables Code for dynamic process variable 3 ■ Byte 3: Device Variables Code for dynamic process variable 4 	<ul style="list-style-type: none"> ■ Byte 0: Device Variables Code for dynamic process variable 1 ■ Byte 1: Device Variables Code for dynamic process variable 2 ■ Byte 2: Device Variables Code for dynamic process variable 3 ■ Byte 3: Device Variables Code for dynamic process variable 4
53	Unit of a Device Variable Access type ■ Write	<ul style="list-style-type: none"> ■ Byte 0: Device Variables Code ■ Byte 1: Unit code 	<ul style="list-style-type: none"> ■ Byte 0: Device Variables Code ■ Byte 1: Unit code
54	Information on a Device Variable Access type ■ Read	<ul style="list-style-type: none"> ■ Byte 0: Device Variables Code 	<ul style="list-style-type: none"> ■ Byte 0: Device Variables Code ■ Byte 1-3: Transmitter serial number ■ Byte 4: Unit code ■ Byte 5-8: Transmitter upper limit ■ Byte 9-12: Transmitter lower limit ■ Byte 13-16: Damping ■ Byte 17-20: Minimum distance from limits ■ Byte 21: Classification ■ Byte 22: Family

No.	HART command/ Access type	Command data ¹⁾	Response data ¹⁾
59	Number of preambles in telegram responses Access type ■ Write	■ Byte 0: number of preambles (2 to 22)	■ Byte 0: number of preambles

1) Numbers in decimal notation



Note!

Code tables and further information can be found in the document CM42PH-LIT-18.pdf.

7.7 Device-specific commands

A detailed description of the device-specific commands can be found in the document CM42PH-LIT-18.pdf on the CD-ROM.



Caution!

The device-specific commands are used by DDs (Device Description) or DTMs (Device Type Manager). Only use these commands "manually" in exceptional cases.

7.8 Status messages

Byte	Bit	Errors/Warnings (group)	Errors/Warnings (local display)
0	0	Temperature sensor failure	F003
0	1	Sensor communication failure	C004, C010, F011
0	2	Sensor failure	F012
0	3	Wrong sensor type	F013
0	4	SCS alarm	F100-F103
0	5	Sensor alarm	F104, F105, M142, F149, F151
0	6	SCS warning	M106, M107, M111, M112
0	7	Sensor warning	M113, M131-M139, M141, M148, M150, M152, M153
1	0	Calibration active	C130
1	1	Internal sensor failure	F170, M171
1	2	Module communication failure	C200, F201
1	3	Module failure	F202, F218
1	4	Module mismatch	F203
1	5	Internal module failure	F212, F218

Byte	Bit	Errors/Warnings (group)	Errors/Warnings (local display)
1	6	Simulation active	C215
1	7	Hold active	C216
2	0	Power bad	M219
2	1	Multidrop active	C221, C220
2	2	Limit alarm	F404, F405
2	3	Limit warning	-
2	4	PARAM menu active	C406
2	5	DIAG menu active	C407
2	6	Software version incompatible	F500
2	7	Internal software failure	F502, M503
3	0	Software configuration failure	F510
3	1	Software framework failure	F513, M514
3	2	Initialization in progress	-
3	3	Initialization failure	F520
3	4	General operation failure	-
3	5	General operation warning	M408
3	6	Internal process value failure	F800, M801
3	7	Measured value limit alarm	F810-F813
4	0	Measured value limit warning	M840-M843
4	1	Process value alarm	-
4	2	Process value warning	-
4	3-7	Not used ¹⁾	-
5, 14-24	0-7	Not used ¹⁾	-

1) Bits that are not used are set to "0".



Note!

Further information on errors and warnings can be found in the "Troubleshooting" section.

8 Troubleshooting

8.1 Troubleshooting instructions

The transmitter constantly monitors its functions itself.

The red alarm LED lights up if the device detects an error. You can read information on the error in the "DIAG/Error messages" menu →  9.

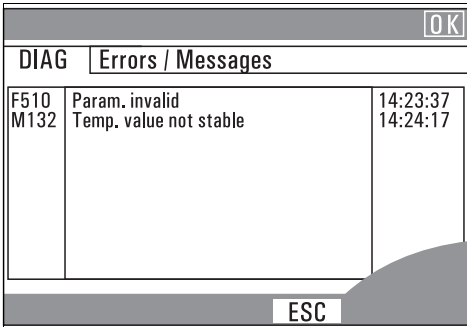

DIAG Errors / Messages		
F510	Param. invalid	14:23:37
M132	Temp. value not stable	14:24:17

ESC

a0002146-en

Fig. 9: Error messages (example)

Please refer to the "Diagnosis messages" Section for the possible error numbers and remedial action.

8.2 Diagnosis messages

In the "DIAG/error messages" menu, you can find additional information on the errors currently pending (red alarm LED lights up³⁾).

The error messages are characterized by:

- Error class (internal variable, not visible)
- Error status (letter in front of the error number)
 - F = Failure, general error message
 - M = Maintenance required, an action is required (measured value is possibly still valid)
 - C = Device is in service (Check), waiting loop (no error)
 - U = Device status is uncertain, unidentifiable error
- Type of message
 - Alarm
 - Maintenance
 - Service

3) Red LED only lights up if the error current is ≥ 20 mA





Note!

You have the option of increasing or decreasing the priority of a pending error. You do this by reorganizing the diagnosis list in the "PARAM/General settings/Devicediagnosis" menu (see Section "PARAM/General settings").

By giving an error currently displayed a lower priority, you can disable an error-related hold and set the device back to the measuring mode.

Example:

Error "M503 Internal C (error number 0815)" is pending. The maintenance icon appears on the device .

Go to the diagnosis list and move the error M503 down in the service error section (Cxxx). Go to the measuring mode. The maintenance icon disappears and  is displayed instead.

Only do this if you are absolutely certain that a critical error is not present and your measuring results still remain plausible. Always inform your Service Team.

The following tables are split by the type of error message.

8.2.1 Alarm messages

No.	Display text	Tests and/or remedial action
F003	Temperature failure	– Check wiring
F011	Sensor no comm.	– Check the measuring chain with a new sensor – Check the settings for the sensor type used.
F012	Sensor failure	
F013	Wrong sensor type	
F104	Contents uncertain	
F105	ISFET leakage current	
F123	Sensor calibration demand	
F125	Sensor lifetime over	
F127	Invalid group number (xxxxxxx)	The (xxxxxxx) stands for the text actually displayed.
F128	Invalid TAG (xxxxxxx)	
F170	Intern S. (xxxxxxx)	Contact the Service Team! Quote the error number and the text displayed. The (xxxxxxx) stands for the text actually displayed.
F172	Alarm operating time	
F173	Usage >80°C alarm	
F174	Usage >100°C alarm	
F175	Usage < -300mV alarm	
F176	Usage >300mV alarm	
F177	Delta slope alarm	
F179	Delta operating point alarm	

No.	Display text	Tests and/or remedial action
F180	Cal. reminder alarm	
F181	No. of sterilizations Alarm	
F201	Transmitter no comm.	Test with a new transmitter module (CPU).
F202	Transmitter failure	
F203	Wrong transmitter type	
F212	Intern E. (xxxxxxx)	Contact the Service Team! Quote the error number and the text displayed. The (xxxxxxx) here stands for the text actually displayed.
F218	Curr.out module defect	Contact the Service Team!
F404	Lower limit current output	<ul style="list-style-type: none"> - Measured value outside the specified current range - Check plausibility - Adjust current output assignment if necessary
F405	Upper limit current output	
F500	Software not valid	Contact the Service Team!
F502	Intern C. (xxxxxxx)	Contact the Service Team! Quote the error number and the text displayed. The (xxxxxxx) here stands for the text actually displayed.
F510	Invalid parameters	Check your settings and adjust them.
F513	InternCFW (xxxxxxx)	Contact the Service Team! Quote the error number and the text displayed. The (xxxxxxx) here stands for the text actually displayed.
F520	No SA communication	Repeat the initialization. If the error occurs again, please contact the Service Team.
F531	(Logbook): full ¹⁾	Delete the logbook entries.
F800	Intern P. (xxxxxxx)	Contact the Service Team! Quote the error number and the text displayed. The (xxxxxxx) here stands for the text actually displayed.
F802	PCS alarm	
F810	PV upper limit	<ul style="list-style-type: none"> - Sensor in air - Air cushion in assembly - Check the measuring chain <p> Note! PV = primary value (main value)</p>
F811	PV lower limit	
F812	Temp upper limit	
F813	Temp lower limit	

1) Variable text: the logbook in question is named.

8.2.2 Maintenance messages

No.	Display text	Tests and/or remedial action
M113	ISFET leakage current	
M124	Sensor calibration recommendation	

No.	Display text	Tests and/or remedial action
M126	Sensor lifetime	
M129	Confirm sensor change	
M131	PV not stable	<ul style="list-style-type: none"> - Sensor too old - Cable or connector defective
M132	Temp. not stable	
M134	Upper limit zeropt. alarm	<ul style="list-style-type: none"> - Sensor old or defective - Diaphragm blocked - Buffer solutions too old or contaminated
M135	Upper limit zeropt. warning	
M136	Lower limit zeropt. warning	
M137	Lower limit zeropt. alarm	
M138	Lower limit slope alarm	
M139	Lower limit slope warning	
M145	ISFET leakage current	
M153	Upper limit operating point	<ul style="list-style-type: none"> - Sensor old or defective - Diaphragm blocked - Buffer solutions too old or contaminated - Potential matching missing (only for symmetrical measurement)
M154	Upper limit operating point	
M155	Lower limit operating point	
M156	Lower limit operating point	
M182	Operating time warning	
M183	Usage >80°C warning	
M184	Usage >100°C warning	
M185	Usage < -300mV warning	
M186	Usage >300mV warning	
M187	Delta slope warning	
M189	Delta operating point warning	
M190	Cal. reminder warning	
M191	No. of sterilizations Warning	
M171	Intern S. (xxxxxxx)	Contact the Service Team! Quote the error number and the text displayed.
M213	Intern E. (xxxxxxx)	
M219	Power supply bad	Connect the device to a clean power supply.
M408	Calibration aborted	Renew calibration solution, repeat calibration
M501	Device open	Close the housing and tighten the screws.
M503	Intern C. (xxxxxxx)	Contact the Service Team! Quote the error number and the text displayed.
M514	Intern CFW. (xxxxxxx)	
M801	Intern P. (xxxxxxx)	

No.	Display text	Tests and/or remedial action
M530	(Logbook): 20% remaining ¹⁾	
M532	Cal. timer expired	
M840	PV upper limit	<ul style="list-style-type: none"> - Sensor in air - Air cushion in assembly - Check the measuring chain
M841	PV lower limit	
M842	Temp upper limit	
M843	Temp lower limit	

1) Variable text: the logbook in question is named.

8.2.3 Service messages

No.	Display text	Tests and/or remedial action
C004	Scanning sensor	
C010	Sensor initialization	Wait for the initialization to finish.
C130	Calibration active	Wait for the calibration to finish.
C200	Transmitter initialization	Wait for the initialization to finish.
C215	Simulation active	Active corresponding to your settings
C216	Hold active	Active corresponding to your settings
C220	Multidrop mode active	
C221	Multidrop switch on	
C406	Param. active	End parameter entry
C407	Diag active	End query of device and sensor information
C519	Init. Software	

8.3 Process errors without messages

Problem	Possible cause	Tests and/or remedial action
Display deviates from comparison measurement	Incorrect calibration	Repeat the calibration. If necessary, check and repeat the calibration with a reference device.
	Sensor contaminated	Clean the sensor.
	Temperature measurement	Check the temperature measured values of both devices.
	Temperature compensation	Check the settings for temperature compensation and adjustment for both devices.

Problem	Possible cause	Tests and/or remedial action
Measuring chain zeropoint cannot be adjusted	Reference system contaminated	Test with new sensor
	Diaphragm blocked	Clean or grind diaphragm
	Asymmetry voltage of sensor too high	Clean diaphragm or test with another sensor
No or creeping display change	<ul style="list-style-type: none"> – Sensor contaminated – Sensor aged – Sensor failure (reference lead) 	Clean the sensor.
Measuring chain slope: <ul style="list-style-type: none"> – Cannot be adjusted – Too low – No slope 	Device input defective	Check device directly.
	– Sensor aged	Replace sensor.
Fixed, incorrect measured value	Sensor not immersing or protection cap not removed	Check installation position, remove protection cap.
	Air cushion in assembly	Check assembly and orientation.
	Ground connection at or in device	Carry out test measurement in isolated vessel, poss. with buffer solution.
	Device has impermissible operating status (no reaction to keys being pressed)	Switch device off and then on again.
Temperature value incorrect	Sensor failure	Replace the sensor
Measured value fluctuations	Interference on signal output line	Check how line is laid, lay line separately if necessary.
	Interference potential in medium	Remove source of interference or ground medium as close as possible to sensor.
No current output signal	Line disconnected or short-circuited	Disconnect line and measure directly at device.
	Output defective	See Section "Device-specific errors".
Fixed current output signal	Current simulation active	Switch off simulation.
Incorrect current output signal	Total load in current loop too high	Disconnect output and measure directly at device.
	EMC (interference coupling)	Disconnect both output lines and measure directly at device.

Problem	Possible cause	Tests and/or remedial action
No HART—communication	Incorrect CPU module	Check nameplate
	<ul style="list-style-type: none"> ■ No or incorrect DD ■ HART interface missing ■ Device not registered in HART server ■ Load too low (> 230 Ω) ■ HART receiver (e.g. FXA191) not connected via load but via power supply ■ Line problems (too long, cross-section too small, not shielded, shield not grounded, cores not twisted) ■ Several devices configured on same address 	Further information is available on the CD-ROM.

8.3.1 Device-specific errors

Problem	Possible cause	Tests and/or remedial action
Display dark	No supply voltage	Check if available.
	CPU defective	Replace CPU, make sure correct version is used.
Display shows information but <ul style="list-style-type: none"> – no change in display and/or – device cannot be operated 	Module incorrectly wired	Check modules and wiring.
	Operating system has impermissible status	Switch device off and then on again.
Implausible measured values	Sensor module defective	First perform tests and take measures as per "Process-specific errors" Section
Current output, current value incorrect	Calibration not correct	Test with integrated current simulation, connect mA meter directly to current output.
	Load too high	
	Shunt/short to ground in current loop	
No current output signal	CPU defective	Test with integrated current simulation, connect mA meter directly to current output.

8.4 Software history

Date	Version	Changes in the software	Documentation: Edition
05/2007	10.04.05	Extension <ul style="list-style-type: none"> ■ Memobase functions 	BA381/07/xx/07.05.01 BA382/07/xx/07.05.01

Date	Version	Changes in the software	Documentation: Edition
06/2006	10.04.00	Extension <ul style="list-style-type: none"> ■ Advanced functionality: <ul style="list-style-type: none"> – Medium compensation pH – Memosens limit contactor 	BA381/07/xx/06.10.01 BA382/07/xx/06.10.01
04/2006	10.03.00	Extension <ul style="list-style-type: none"> ■ Advanced functionality: <ul style="list-style-type: none"> – Pfaudler electrodes – Predictive maintenance: PCS, SCC, calibration timer ■ Software update via DAT modules ■ Date and time format selectable ■ Language extension ■ Diagnosis table, advanced diagnosis codes 	BA381/07/xx/06.05.01 BA382/07/xx/06.05.01
09/2005	10.02.00	Extension <ul style="list-style-type: none"> ■ PROFIBUS Profile 3.0 ■ Upload / Download mode ■ Extension of the Memosens data 	BA381/07/xx/05.11.01 BA382/07/xx/05.11.01
07/2005	10.01.00	Improvement <ul style="list-style-type: none"> ■ Correction of the Memosens functionality ■ Extended error codes ■ Additional types of calibration ■ Improvement of the update behavior 	BA381/07/xx/05.08.01 BA382/07/xx/05.08.01
06/2005	10.00.00	Original software	BA381/07/xx/05.05.24 BA382/07/xx/05.05.24

Index

C

CAL	27–28
Calibrate	28
Menu	28
Calibration	27
Change sensor	22
Common practice commands	36
Communication	
HART	34, 36, 38
Current output	13

D

Device identification	32
Device information	23
Device-specific commands	38
DIAG	22
Diagnosis messages	40
Display	4, 18
Display menu	18

E

Editing tables	5
Error messages	22
Alarm	41
Maintenance	42
Service	44
Errors	40

F

Faults	40
Fieldcare	32
Function group	
CAL	27
DIAG	22
MEAS	6
PARAM	6

G

General settings	14
------------------	----

H

HART	
Common practice commands	36
Device identification	32
Device-specific commands	38

Interfaces	33
Multidrop mode	33
Status messages	38
Universal commands	34
HART Communicator	31

I

Interfaces	33
------------	----

L

Local display	4
Logbooks	23

M

MEAS	6
Menu	
Current output	13
Device information	23
Display	18
Error messages	22
General settings	14
Logbooks	23
Output state	23
Quick Setup	19
Sensor	6, 26
Sensor information	25
Service	27
Multidrop mode	33

O

Operating concept	2
Output state	23

P

PARAM	6
Process errors	44

Q

Quick Setup	19
-------------	----

S

Sensor	6, 26
Sensor information	25
Service	27
Software description	

CAL	27
Current output	13
Device information	23
DIAG	22
Display	18
Error messages	22
General settings	14
Logbooks	23
MEAS	6
Output state	23
PARAM	6
Quick Setup	19
Sensor	6, 26
Sensor information	25
Service	27
Software history	46
Status messages	4, 38

T

Types of calibration	27
Types of setting	5

U

Universal commands	34
User administration	5

www.endress.com/worldwide

Endress+Hauser 
People for Process Automation
