

Operating Instructions

Proline Promag 55

HART

Electromagnetic Flow Measuring System

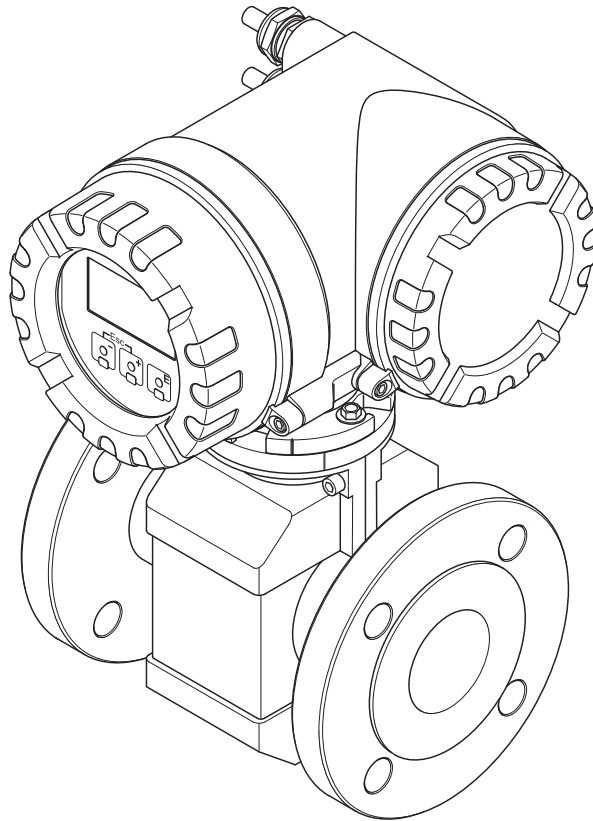

Table of contents

1	Safety instructions	4	9	Troubleshooting	85
1.1	Designated use	4	9.1	Troubleshooting	85
1.2	Installation, commissioning, operation	4	9.2	System error messages	86
1.3	Operational safety	5	9.3	Process error messages	90
1.4	Return	5	9.4	Process errors without message	90
1.5	Notes on safety conventions and icons	5	9.5	Response of outputs to errors	92
2	Identification	6	9.6	Spare parts	94
2.1	Device designation	6	9.7	Return	100
2.2	Certificates and approvals	9	9.8	Disposal	100
2.3	Registered trademarks	9	9.9	Software history	100
3	Installation	10	10	Technical data	101
3.1	Incoming acceptance, transport and storage ...	10	10.1	Application	101
3.2	Installation conditions	12	10.2	Function and system design	101
3.3	Installation	20	10.3	Input	101
3.4	Post-installation check	32	10.4	Output	101
4	Wiring	33	10.5	Power supply	102
4.1	Connecting the remote version	33	10.6	Performance characteristics	103
4.2	Connecting the measuring unit	38	10.7	Installation	104
4.3	Potential equalization	42	10.8	Environment	104
4.4	Degree of protection	44	10.9	Process	105
4.5	Post-connection check	45	10.10	Mechanical construction	109
5	Operation	46	10.11	Operability	113
5.1	Display and operating elements	46	10.12	Certificates and approvals	114
5.2	Brief operating instruction to the function matrix .	49	10.13	Ordering information	115
5.3	Error messages	51	10.14	Accessories	115
5.4	Communication	52	10.15	Documentation	115
6	Commissioning	64	Index	116	
6.1	Function check	64			
6.2	Switching on the measuring device	64			
6.3	Quick Setup	65			
6.4	Configuration	71			
6.5	Adjustment	79			
6.6	Data storage devices	80			
7	Maintenance	81			
7.1	Exterior cleaning	81			
7.2	Seals	81			
8	Accessories	82			
8.1	Device-specific accessories	82			
8.2	Measuring principle-specific accessories	82			
8.3	Communication-specific accessories	83			
8.4	Communication-specific accessories	83			

1 Safety instructions

1.1 Designated use

The measuring device described in this Operating Manual is to be used only for measuring the flow rate of conductive fluids in closed pipes.

A minimum conductivity of 20 $\mu\text{S}/\text{cm}$ is required for measuring demineralized water. Most liquids can be measured as of a minimum conductivity of 5 $\mu\text{S}/\text{cm}$.

- Acids, alkalis, pastes, paps, pulps, black liquor, green liquor,
- Drinking water, wastewater, sewage sludge,
- Cement, ore slurry (containing sand or stone), mud, silt.

Resulting from incorrect use or from use other than that designated the operational safety of the measuring devices can be suspended. The manufacturer accepts no liability for damages being produced from this.



1.2 Installation, commissioning, operation

Note the following points:

- Installation, connection to the electricity supply, commissioning and maintenance of the device must be carried out by trained, qualified specialists authorized to perform such work by the facility's owner-operator. The specialist must have read and understood this Operating Manual and must follow the instructions it contains.
- The device must be operated by persons authorized and trained by the facility's owner-operator. Strict compliance with the instructions in the Operating Manual is mandatory.
- Endress+Hauser is willing to assist in clarifying the chemical resistance properties of parts wetted by special fluids, including fluids used for cleaning. However, small changes in temperature, concentration or the degree of contamination in the process can result in changes of the chemical resistance properties. Therefore, Endress+Hauser can not guarantee or accept liability for the chemical resistance properties of the fluid wetted materials in a specific application. The user is responsible for the choice of fluid wetted materials in regards to their in-process resistance to corrosion.
- If welding work is performed on the piping system, do not ground the welding appliance through the flowmeter.
- The installer must ensure that the measuring system is correctly wired in accordance with the wiring diagrams. The transmitter must be grounded, except in cases where special protective measures have been taken (e.g. galvanically isolated power supply SELV or PELV).
- Always note the regulations applicable in your country to the operation, maintenance and repair of electrical devices. Special instructions relating to the device can be found in the relevant sections of this documentation.
- The Promag 55 flow measuring device can also measure extremely abrasive fluids, e.g. ore slurry, cement etc. To protect the measuring tube lining from excessive abrasion, the use of additional liner protection plates is recommended in such cases.

1.3 Operational safety

Note the following points:

- Measuring systems for use in hazardous environments are accompanied by separate "Ex documentation", which is an integral part of this Operating Manual. Strict compliance with the installation instructions and ratings as stated in this supplementary documentation is mandatory. The symbol on the front of this supplementary Ex documentation indicates the approval and the certification body (e.g.  Europe,  USA,  Canada)
- The measuring device meets the general safety requirements according to EN 61010-1 and the EMC requirements according to IEC/EN 61326 in addition to the NAMUR recommendations NE 21, NE 43 and NE 53.
- Depending on the application, the seals of the process connections of the Promag H sensor require periodic replacement.
- Due to the performance rate in the electronic components, the maximum heating of the outer housing surfaces is 10 K. When hot media are passed through the measuring tube, the surface temperature of the housing increases. With regard to the sensor, in particular, you should expect temperatures that can be close to the fluid temperature. If the temperature of the fluid is high, ensure staff are protected against burns and scalds.
- The manufacturer reserves the right to modify technical data without prior notice. Your Endress+Hauser distributor will supply you with current information and updates to this Operating Manual.

1.4 Return

The measuring device must be returned if repairs or a factory calibration are required, or if the wrong measuring device has been ordered or delivered. According to legal regulations, Endress+Hauser, as an ISO-certified company, is required to follow certain procedures when handling returned products that are in contact with medium.

To ensure swift, safe and professional device returns, please read the return procedures and conditions on the Endress+Hauser website at www.services.endress.com/return-material

1.5 Notes on safety conventions and icons

The devices are designed and tested to meet state-of-the-art safety requirements, and have left the factory in a condition in which they are safe to operate. The devices comply with the applicable standards and regulations in accordance with EN 61010 -1 "Protection Measures for Electrical Equipment for Measurement, Control, Regulation and Laboratory Procedures". The devices can, however, be a source of danger if used incorrectly or for other than the designated use.

Consequently, always pay particular attention to the safety instructions indicated in this Operating Manual by the following icons:



Warning!

"Warning" indicates an action or procedure which, if not performed correctly, can result in injury or a safety hazard. Comply strictly with the instructions and proceed with care.



Caution!

"Caution" indicates an action or procedure which, if not performed correctly, can result in incorrect operation or destruction of the device. Comply strictly with the instructions.



Note!

"Note" indicates an action or procedure which, if not performed correctly, can have an indirect effect on operation or trigger an unexpected response on the part of the device.

2 Identification

2.1 Device designation

The flow measuring system consists of the following components:

- Promag 55 Transmitter
- Promag S or Promag H Sensor

Two versions are available:

- Compact version: Transmitter and sensor form a single mechanical unit.
- Remote version: Transmitter and sensor are installed separately.

2.1.1 Nameplate of the transmitter

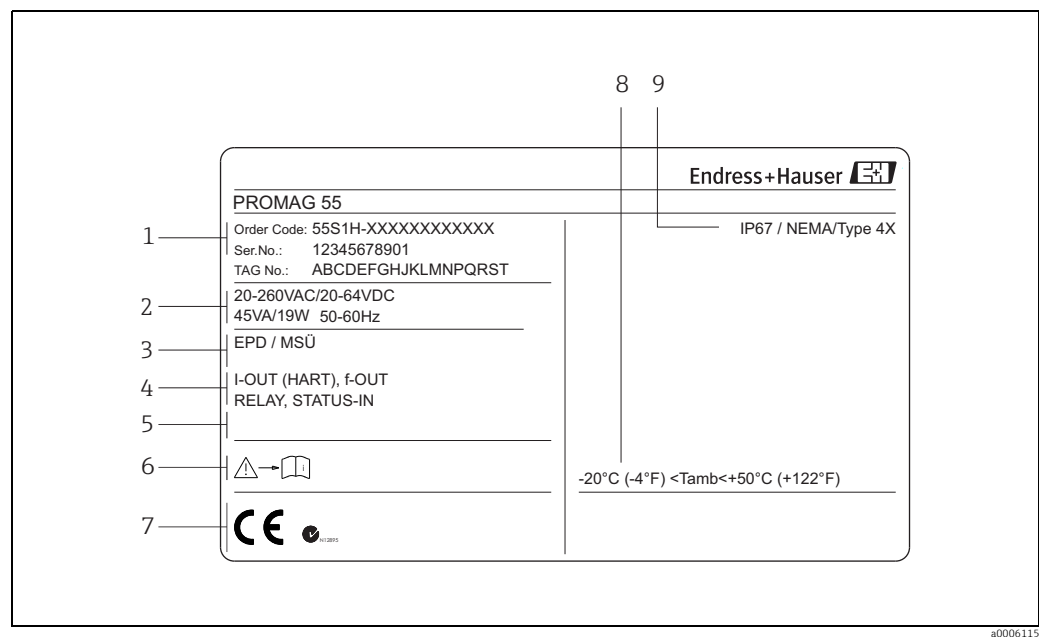

Fig. 1: Nameplate specifications for the "Promag 55" transmitter (example)

- 1 Order code/serial number: See the specifications on the order confirmation for the meanings of the individual letters and digits
- 2 Power supply/frequency/power consumption
- 3 Additional information
 - EPD: with empty pipe detection electrode
 - ECC: with electrode cleaning
- 4 Available inputs and outputs
- 5 Reserved for additional information on special products
- 6 Observe device documentation
- 7 Reserved for additional information on device version (approvals, certificates)
- 8 Permitted ambient temperature range
- 9 Degree of protection

2.1.2 Nameplate of the sensor

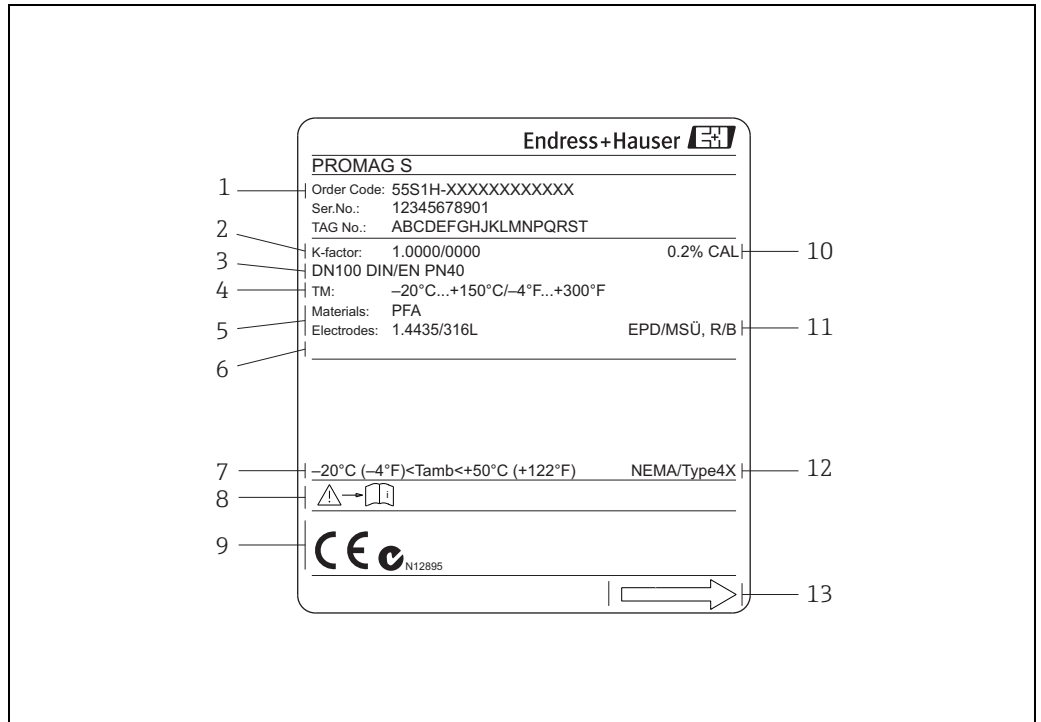

Fig. 2: Nameplate specifications for the "Promag" sensor (example)

- 1 Order code/serial number: See the specifications on the order confirmation for the meanings of the individual letters and digits
- 2 Calibration factor with zero point
- 3 Nominal diameter/nominal pressure
- 4 Fluid temperature range
- 5 Materials: lining/measuring electrode
- 6 Reserved for additional information on special products
- 7 Permitted ambient temperature range
- 8 Observe device documentation
- 9 Reserved for additional information on device version (approvals, certificates)
- 10 Calibration tolerance
- 11 Additional information
 - EPD: with empty pipe detection electrode
 - R/B: with reference electrode
- 12 Degree of protection
- 13 Flow direction

2.1.3 Nameplate, connections

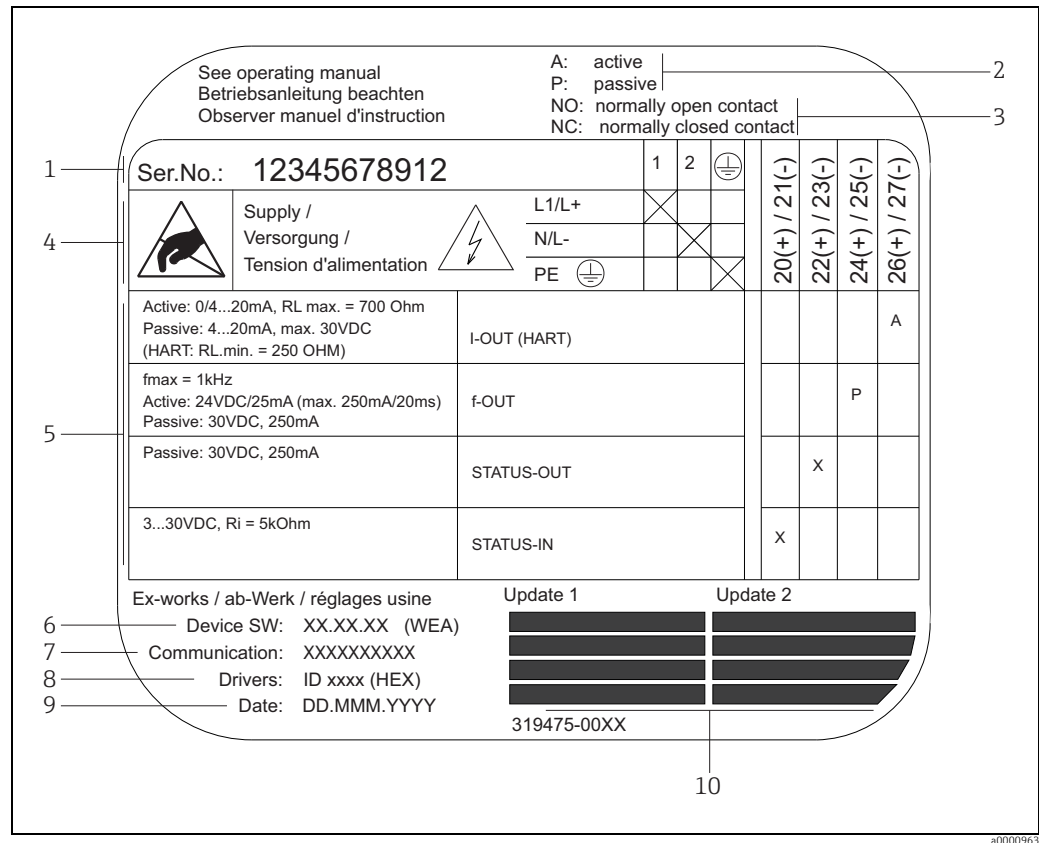

Fig. 3: Nameplate specifications for Proline transmitter connections (example)

- 1 Serial number
- 2 Possible configuration of current output
- 3 Possible configuration of relay contacts
- 4 Terminal assignment, cable for power supply: 20 to 260 V AC, 20 to 64 V DC
Terminal No. 1: L1 for AC, L+ for DC
Terminal No. 2: N for AC, L- for DC
- 5 Signals present at inputs and outputs, possible configurations and terminal assignment
- 6 Version of device software currently installed (incl. language group)
- 7 Type of communication installed
- 8 Information on current communication software (Device Revision, Device Description)
- 9 Date of installation
- 10 Current updates to data specified in points 6 to 9

2.2 Certificates and approvals

The devices are designed and tested to meet state-of-the-art safety requirements in accordance with sound engineering practice. They have left the factory in a condition in which they are safe to operate. The devices comply with the standards EN 61010 -1 "Protection Measures for Electrical Equipment for Measurement, Control, Regulation and Laboratory Procedures" and with the EMC requirements of IEC/EN 61326. The measuring system described in these Operating Instructions therefore complies with the legal requirements of the EU Directives. Endress+Hauser confirms this by affixing the CE mark to it and by issuing the CE declaration of conformity. The measuring system is in conformity with the EMC requirements of the "Australian Communications and Media Authority (ACMA)".

2.3 Registered trademarks

HART®

Registered trademark of HART Communication Foundation, Austin, USA

TRI-CLAMP®

Registered trademark of Ladish & Co., Inc., Kenosha, USA

KALREZ® and VITON®

Registered trademarks of E.I. Du Pont de Nemours & Co., Wilmington, USA

HistoROM™, S-DAT®, T-DAT™, F-CHIP®, Field Xpert™, FieldCare®, Fieldcheck®, Applicator®

Registered or registration-pending trademarks of the Endress+Hauser Group

3 Installation

3.1 Incoming acceptance, transport and storage

3.1.1 Incoming acceptance

On receipt of the goods, check the following points:

- Check the packaging and the contents for damage.
- Check the shipment, make sure nothing is missing and that the scope of supply matches your order.

3.1.2 Transport

The following instructions apply to unpacking and to transporting the device to its final location:

- Transport the devices in the containers in which they are delivered.
- Do not remove the protection plates or caps on the process connections until you are ready to install the device. This is particularly important in the case of sensors with PTFE linings.

Special notes on flanged devices



Caution!

- The wooden covers mounted on the flanges before the device leaves the factory protect the linings on the flanges during storage and transportation. Do not remove these protection plates until *immediately before* the device is installed in the pipe.
- Do not lift flanged devices by the transmitter housing, or the connection housing in the case of the remote version.

Transporting flanged devices (DN ≤ 300/12")

Use webbing slings slung round the two process connections. Do not use chains, as they could damage the housing.



Warning!

Risk of injury if the measuring device slips. The center of gravity of the assembled measuring device might be higher than the points around which the slings are slung.

At all times, therefore, make sure that the device does not unexpectedly turn around its axis or slip.

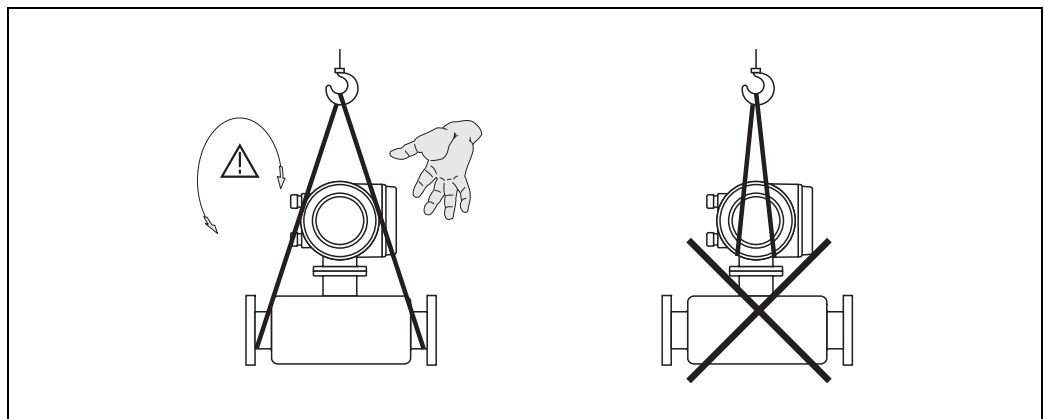

Fig. 4: Transporting sensors with DN ≤ 300/12"

a0004294

Transporting flanged devices (DN > 300/12")

Use only the metal eyes on the flanges for transporting the device, lifting it and positioning the sensor in the piping.



Caution!

Do not attempt to lift the sensor with the tines of a fork-lift truck beneath the metal casing. This would buckle the casing and damage the internal magnetic coils.

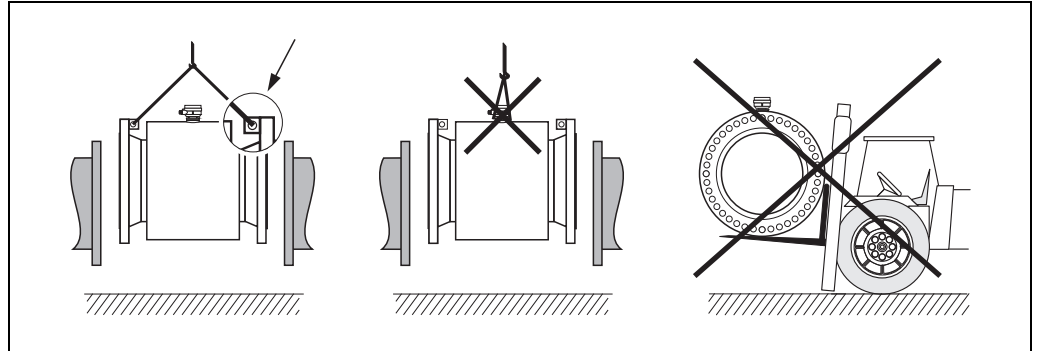

Fig. 5: Transporting sensors with DN > 300 (12")

3.1.3 Storage

Note the following points:

- Pack the measuring device in such a way as to protect it reliably against impact for storage (and transportation). The original packaging provides optimum protection.
- The storage temperature corresponds to the operating temperature range of the measuring transmitter and the appropriate measuring sensors → 104.
- The measuring device must be protected against direct sunlight during storage in order to avoid unacceptably high surface temperatures.
- Choose a storage location where moisture does not collect in the measuring device. This will help prevent fungus and bacteria infestation which can damage the liner.
- Do not remove the protection plates or caps on the process connections until you are ready to install the device. This is particularly important in the case of sensors with PTFE linings.

3.2 Installation conditions

3.2.1 Dimensions

The dimensions and installation lengths of the sensor and transmitter can be found in the "Technical Information" for the device in question. This document can be downloaded as a PDF file from www.endress.com. A list of the "Technical Information" documents available is provided in the "Documentation" section on → [115](#).

3.2.2 Location

The accumulation of air or gas bubbles in the measuring tube could result in an increase in measuring errors. **Avoid** the following locations:

- At the highest point of a pipeline. Risk of air accumulating.
- Directly upstream from a free pipe outlet in a vertical pipeline.

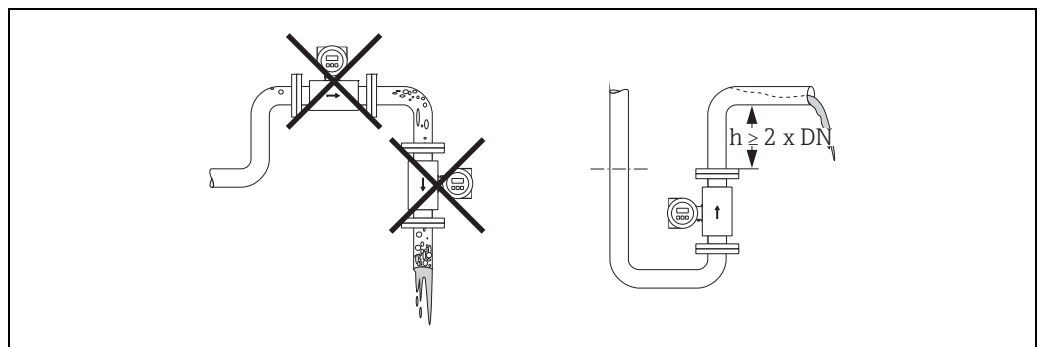

Fig. 6: Location

Installing pumps

Do not install the sensor on the intake side of a pump. This precaution is to avoid low pressure and the consequent risk of damage to the lining of the measuring tube. Information on the lining's resistance to partial vacuum → [107](#).

It might be necessary to install pulse dampers in systems incorporating reciprocating, diaphragm or peristaltic pumps. Information on the measuring system's resistance to vibration and shock → [104](#).

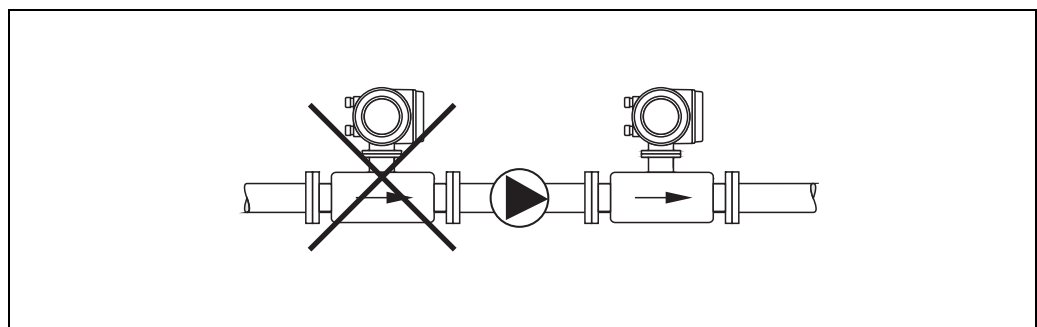

Fig. 7: Installing pumps

Partially filled pipes

Partially filled pipes with gradients necessitate a drain-type configuration. The Empty Pipe Detection function offers additional protection by detecting empty or partially filled pipes → [79](#).



Caution!

Risk of solids accumulating. Do not install the sensor at the lowest point in the drain. It is advisable to install a cleaning valve.

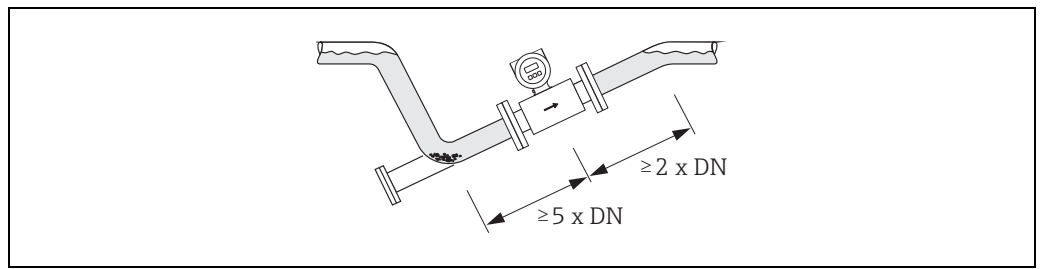

Fig. 8: Installation in partially filled pipe

A0008155

Down pipes

Install a siphon or a vent valve downstream of the sensor in down pipes longer than 5 m (16.3 ft). This precaution is to avoid low pressure and the consequent risk of damage to the lining of the measuring tube. This measure also prevents the system losing prime, which could cause air inclusions. Information on the lining's resistance to partial vacuum → 107.

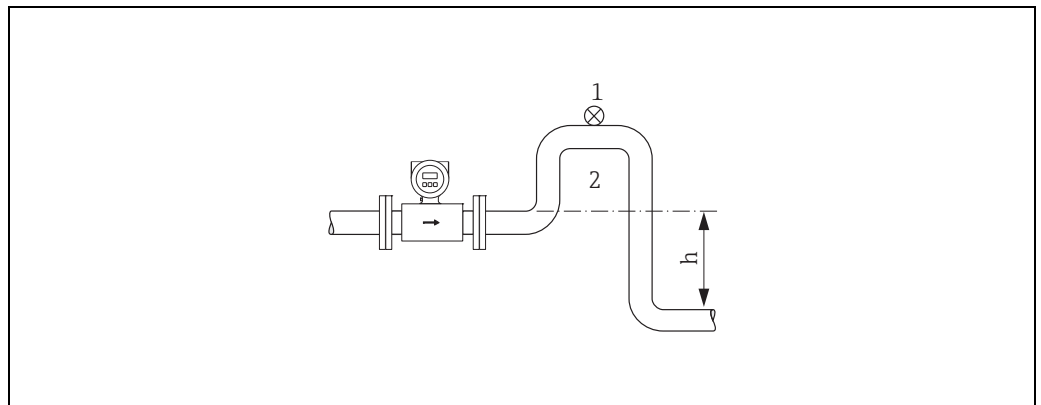

Fig. 9: Measures for installation in a down pipe

A0008157

- 1 Vent valve
- 2 Siphon
- h Length of down pipe ($h \geq 5 \text{ m (16.3 ft)}$)

3.2.3 Orientation

An optimum orientation position helps avoid gas and air accumulations and deposits in the measuring tube. Promag, nevertheless, supplies a range of functions and accessories for correct measuring of problematic fluids:

- Electrode Cleaning Circuit (ECC) for applications with fluids producing build-up, e.g. electrically conductive deposits → "Description of Device Functions" manual.
- Empty Pipe Detection (EPD) ensures the detection of partially filled measuring tubes, e.g. in the case of degassing fluids → 79.

Vertical orientation

A vertical orientation is ideal in the following cases:

- For self-emptying piping systems and when using empty pipe detection.
- For sludge containing sand or stones and where the solids cause sedimentation.

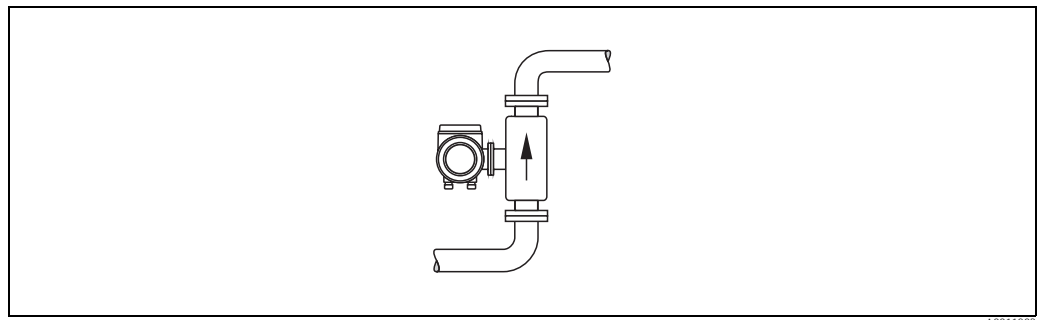

Fig. 10: Vertical orientation

Horizontal orientation

The measuring electrode plane should be horizontal. This prevents brief insulation of the two electrodes by entrained air bubbles.



Caution!

Empty Pipe Detection functions correctly with the measuring device installed horizontally only when the transmitter housing is facing upward (see diagram). Otherwise there is no guarantee that Empty Pipe Detection will respond if the measuring tube is only partially filled.

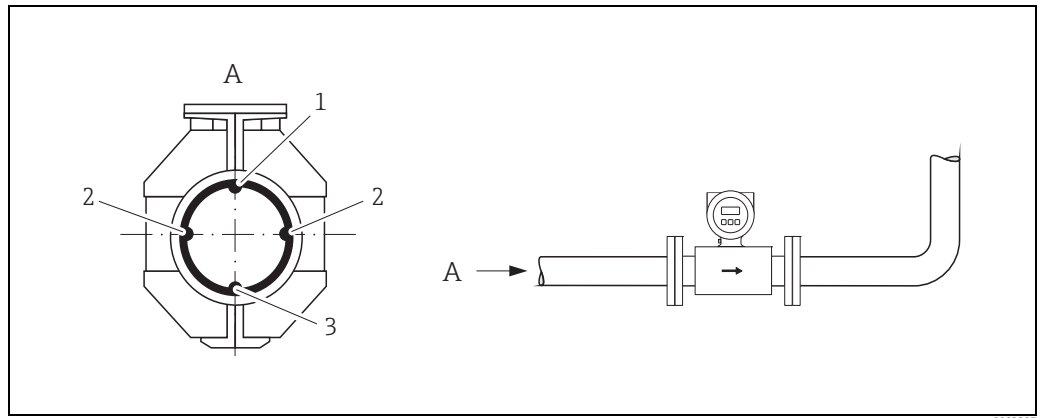

Fig. 11: Horizontal orientation

- 1 EPD electrode for empty pipe detection
(not available for "measuring electrode only" option, not in Promag H, DN 2 to 8/ 1/2 to 5/16")
- 2 Measuring electrodes for signal detection
- 3 Reference electrode for potential equalization
(not available for "measuring electrode only" option, not in Promag H)

3.2.4 Inlet and outlet runs

If possible, install the sensor well clear of fittings such as valves, T-pieces, elbows, etc.

Compliance with the following requirements for the inlet and outlet runs is necessary in order to ensure measuring accuracy.

- Inlet run $\geq 5 \times \text{DN}$
- Outlet run $\geq 2 \times \text{DN}$

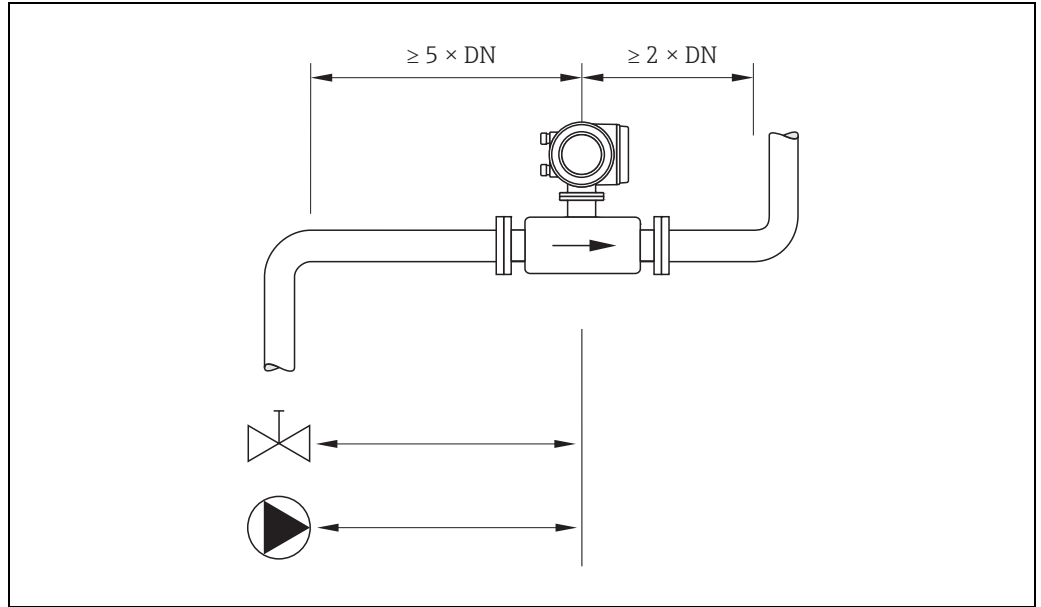

Fig. 12: Inlet and outlet runs

3.2.5 Vibrations

Secure and fix both the piping and the sensor if the vibrations are severe.



Caution!

It is advisable to install sensor and transmitter separately if vibration is excessively severe. Information on the permitted resistance to vibration and shock → 104.

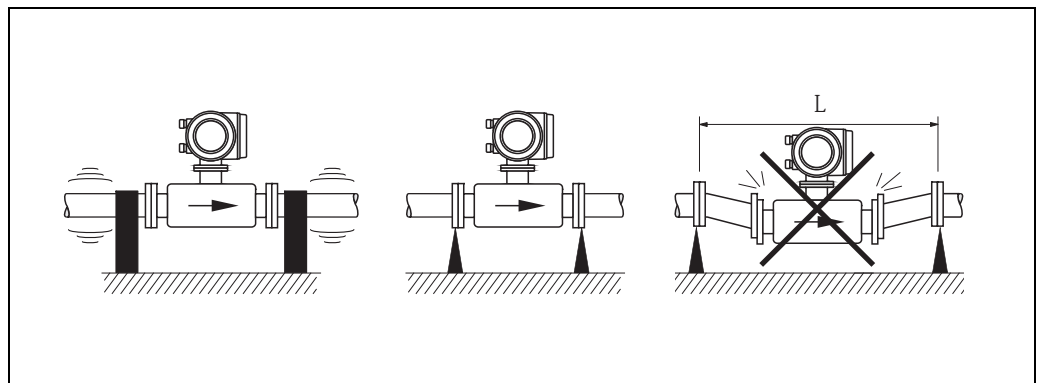

Fig. 13: Measures to prevent vibration of the measuring device ($L > 10 \text{ m}/33 \text{ ft}$)

3.2.6 Foundations, supports

If the nominal diameter is $DN \geq 350$ (14"), mount the sensor on a foundation of adequate load-bearing strength.



Caution!

Risk of damage.

Do not support the weight of the sensor on the metal casing: the casing would buckle and damage the internal magnetic coils.

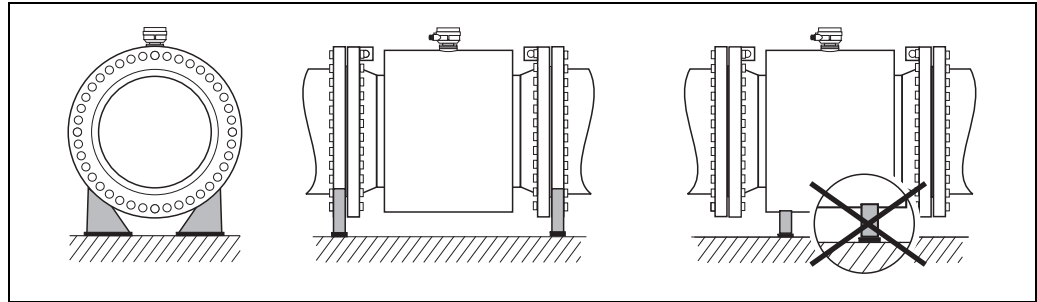

Fig. 14: Correct support for large nominal diameters ($DN \geq 350/14''$)

3.2.7 Adapters

Suitable adapters to DIN EN 545 (double-flange reducers) can be used to install the sensor in larger-diameter pipes. The resultant increase in the rate of flow improves measuring accuracy with very slow-moving fluids.

The nomogram shown here can be used to calculate the pressure loss caused by cross-section reduction.



Note!

- The nomogram only applies to liquids of viscosity similar to water.
- For Promag H the selection of a pipe with larger diameter for high viscosities of the fluid may be considered to reduce the pressure loss.

1. Calculate the ratio of the diameters d/D .
2. From the nomogram, read off the pressure loss as a function of fluid velocity (*downstream* from the reduction) and the d/D ratio.

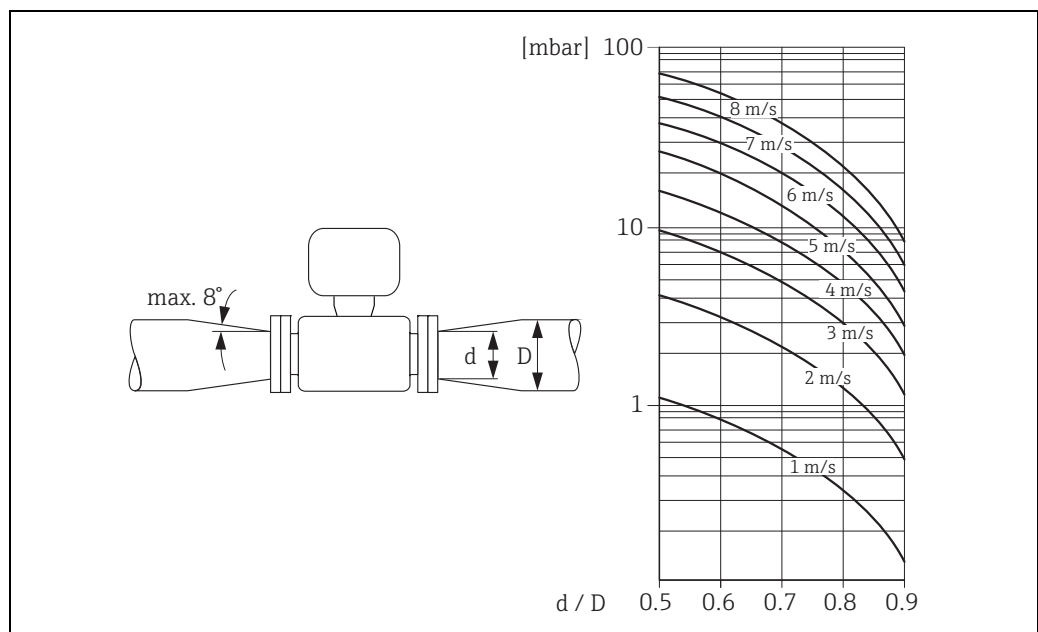

Fig. 15: Pressure loss due to adapters

3.2.8 Nominal diameter and flow rate

The diameter of the pipe and the flow rate determine the nominal diameter of the sensor. The optimum flow velocity is between 2 and 3 m/s (6.5 to 9.8 ft/s). The flow velocity (v), moreover, has to be matched to the physical properties of the fluid:

- $v < 2$ m/s (< 6 ft/s): for abrasive fluids where solids do not cause sedimentation (e.g. lime milk)
- $v > 2$ m/s (> 6 ft/s): for fluids producing buildup
- $v > 2$ m/s (> 6 ft/s): for abrasive sludge with a high sand or stone content and where the solids easily cause sedimentation (e.g. ore slurry)



Note!

- A necessary increase in the flow velocity can be achieved by reducing the sensor nominal diameter through the use of adapters → 16.
- For Promag H the selection of a pipe with nominal diameter $> \text{DN } 8$ ($\frac{3}{8}$ ") for fluids with high levels of solids may be considered, to improve the stability of the signal and cleanability due to larger electrodes.

Recommended flow (SI units)

Nominal diameter [mm]	Promag S	Promag H	Factory settings Promag S	Factory settings Promag H		
	min./max. full scale value ($v \approx 0.3$ or 10 m/s) [dm ³ /min]		Low flow cut off ($v \approx 0.04$ m/s) in [dm ³ /min]	Full scale value ($v \approx 2.5$ m/s) [dm ³ /min]	Pulse value (≈ 2 Pulse/s) [dm ³]	Low flow cut off ($v \approx 0.04$ m/s) [dm ³ / min]
2	–	0.06 to 1.8	–	0.5	0.005	0.01
4	–	0.25 to 7	–	2	0.025	0.05
8	–	1 to 30	–	8	0.10	0.1
15	4 to 100	4 to 100	0.5	25	0.20	0.5
25	9 to 300	9 to 300	1	75	0.50	1
32	15 to 500	15 to 500	2	125	1.00	2
40	25 to 700	25 to 700	3	200	1.50	3
50	35 to 1100	35 to 1100	5	300	2.50	5
65	60 to 2000	60 to 2000	8	500	5.00	8
80	90 to 3000	90 to 3000	12	750	5.00	12
100	145 to 4700	145 to 4700	20	1200	10.00	20
125	220 to 7500	220 to 7500	30	1850	15	30
[mm]	min./max. full scale value ($v \approx 0.3$ or 10 m/s) in [m ³ /h]					
150	20 to 600	20 to 600	2.5	150	0.03	2.5
200	35 to 1100	–	5.0	–	–	–
250	55 to 1700	–	7.5	–	–	–
300	80 to 2400	–	10	–	–	–
350	110 to 3300	–	15	–	–	–
400	140 to 4200	–	20	–	–	–
450	180 to 5400	–	25	–	–	–
500	220 to 6600	–	30	–	–	–
600	310 to 9600	–	40	–	–	–

Recommended flow (US units)

Nominal diameter [inch]	Promag S	Promag H	Factory settings Promag S	Factory settings Promag H		
	min./max. full scale value (v ≈ 1.0 or 33 ft/s) in [gal/min]		Low flow cut off (v ≈ 1.0 ft/s) in [gal/min]	full scale value (v ≈ 2.5 m/s) [gal/min]	Pulse value (≈ 2 Pulse/s) [gal]	Low flow cut off (v ≈ 0.04 m/s) [gal/ min]
1/12"	–	0.015 to 0.5	–	0.1	0.001	0.002
1/8"	–	0.07 to 2	–	0.5	0.005	0.008
3/8"	–	0.25 to 8	–	2	0.02	0.025
1/2"	1.0 to 27	1.0 to 27	0.10	6	0.05	0.10
1"	2.5 to 80	2.5 to 80	0.25	18	0.20	0.25
1 1/2"	7 to 190	7 to 190	0.75	50	0.50	0.75
2"	10 to 300	10 to 300	1.25	75	0.50	1.25
3"	24 to 800	24 to 800	2.5	200	2	2.5
4"	40 to 1250	40 to 1250	4.0	300	2	4.0
6"	90 to 2650	90 to 2650	12	–	–	–
8"	155 to 4850	–	15	–	–	–
10"	250 to 7500	–	30	–	–	–
12"	350 to 10600	–	45	–	–	–
14"	500 to 15000	–	60	–	–	–
16"	600 to 19000	–	60	–	–	–
18"	800 to 24000	–	90	–	–	–
20"	1000 to 30000	–	120	–	–	–
24"	1400 to 44000	–	180	–	–	–

3.2.9 Length of connecting cable

In order to ensure measuring accuracy, comply with the following instructions when installing the remote version:

- Secure the cable run or route the cable in an armored conduit. Movement of the cable can falsify the measuring signal, particularly if the fluid conductivity is low.
- Route the cable well clear of electrical machines and switching elements.
- Ensure potential equalization between sensor and transmitter, if necessary.
- The permissible cable length L_{max} depends on the fluid conductivity (Fig. 16, Fig. 17).
- The maximum connecting cable length is 10 m (32.8 ft) when empty pipe detection (EPD → 79) is switched on.

Promag S

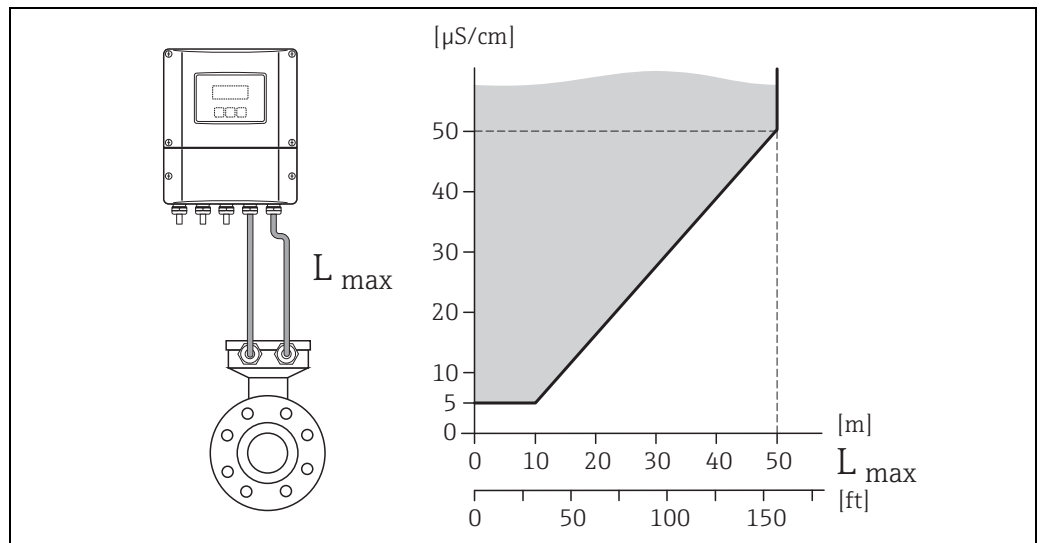

Fig. 16: Permitted lengths for connecting cable in remote version, as a function of the conductivity of the fluid

Gray shaded area = permissible area
 L_{max} = Length of connecting cable

Promag H

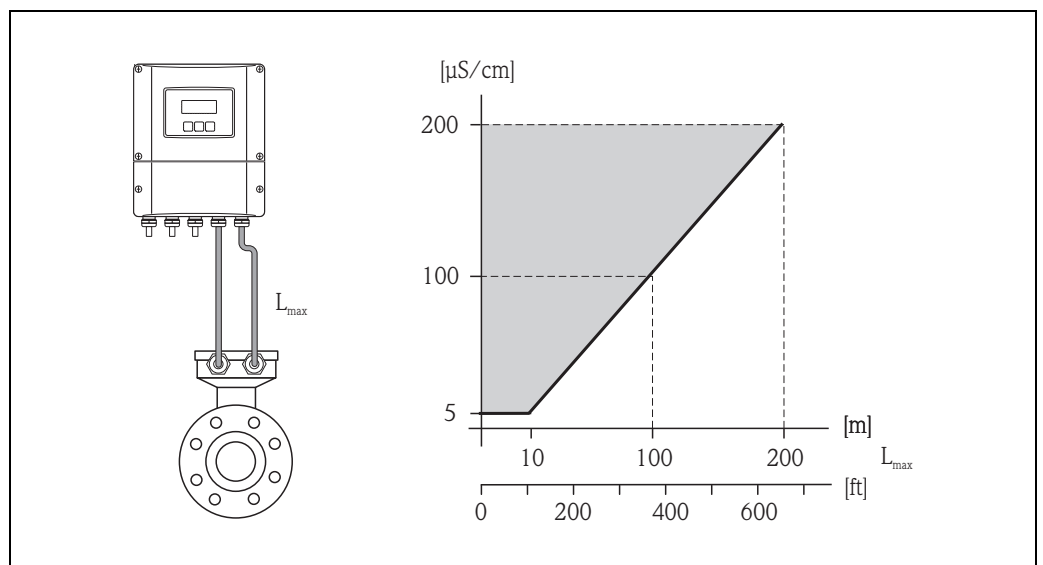

Fig. 17: Permitted lengths for connecting cable in remote version, as a function of the conductivity of the fluid

Gray shaded area = permissible area
 L_{max} = Length of connecting cable

3.3 Installation

3.3.1 Installing the Promag S sensor



Note!

Bolts, nuts, seals, etc. are not included in the scope of supply and must be supplied by the customer.



Caution!

- The protective covers mounted on the two sensor flanges guard the PTFE lining, which is turned over the flanges. Consequently, do not remove these protection plates until *immediately before* the sensor is installed in the pipe.
- Protection plates must remain in place while the device is in storage.
- Make sure that the lining is not damaged or removed from the flanges.

The sensor is designed for installation between the two piping flanges:

- It is essential that you observe the necessary torques on → 21.
- If grounding disks are used, follow the mounting instructions which will be enclosed with the shipment.

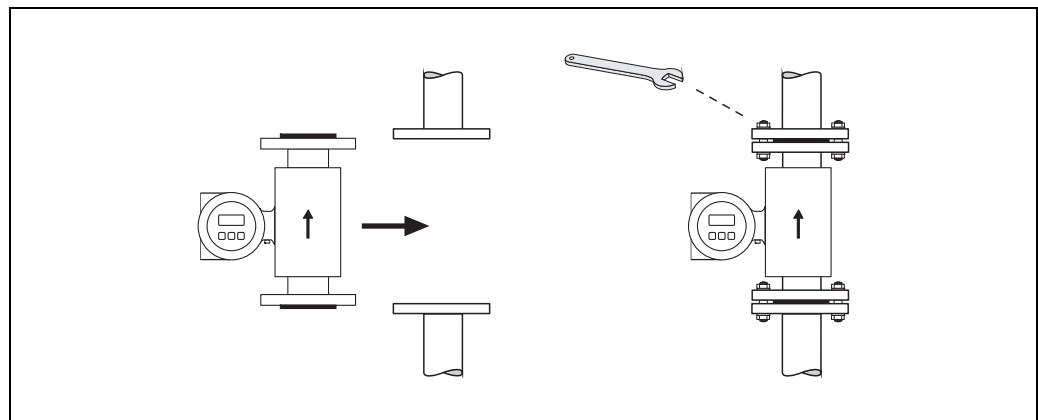

Fig. 18: Installing the Promag S sensor

Seals

Comply with the following instructions when installing seals:

- Hard rubber lining \neq additional seals are always necessary!
- Natural rubber lining → Seals may **not** be used.
- PFA, PTFE or PU (polyurethane) lining → **No** seals are required.
- Make sure that the seals do not protrude into the piping cross-section.



Caution!

Risk of short circuit! Do not use electrically conductive sealing compound such as graphite. An electrically conductive layer could form on the inside of the measuring tube and short-circuit the measuring signal.

Ground cable (DN 15 to 600 / ½ to 24")

Ground cables are optionally available in different versions from Endress+Hauser:

- Ground cable preinstalled at the flange → Order option (see price list).
- Ground cable (not pre-installed) as an accessory → 82.

Detailed assembly instructions → 42.

Screw tightening torques

Please note the following:

- The screw tightening torques listed below apply only to lubricated threads and to pipes not subjected to tensile stress.
- Tighten the screws uniformly and in diagonally opposite sequence.
- Overtightening the screws will deform the sealing faces or damage the seals.

Tightening torques for:

- EN (DIN) → 21
- ASME B16.5 → 22
- JIS → 23
- AS 2129 → 24
- AS 4087 → 24

Promag S screw tightening torques for EN 1092-1 (DIN 2501), PN 10/16/25/40

Nominal diameter [mm]	EN (DIN) Pressure rating	Threaded fasteners	Flange thickness [mm]	Max. tightening torque				
				Natural rubber [Nm]	Polyurethane [Nm]	PTFE [Nm]	PFA [Nm]	Hard rubber [Nm]
15	PN 40	4 × M 12	16	–	–	11	–	–
25	PN 40	4 × M 12	18	–	15	26	20	–
32	PN 40	4 × M 16	18	–	24	41	35	–
40	PN 40	4 × M 16	18	–	31	52	47	–
50	PN 40	4 × M 16	20	–	40	65	59	48
65 *	PN 16	8 × M 16	18	11	27	43	40	32
65	PN 40	8 × M 16	22	–	27	43	40	32
80	PN 16	8 × M 16	20	13	34	53	48	40
80	PN 40	8 × M 16	24	–	34	53	48	40
100	PN 16	8 × M 16	20	14	36	57	51	43
100	PN 40	8 × M 20	24	–	50	78	70	59
125	PN 16	8 × M 16	22	19	48	75	67	56
125	PN 40	8 × M 24	26	–	71	111	99	83
150	PN 16	8 × M 20	22	27	63	99	85	74
150	PN 40	8 × M 24	28	–	88	136	120	104
200	PN 10	8 × M 20	24	35	91	141	101	106
200	PN 16	12 × M 20	24	28	61	94	67	70
200	PN 25	12 × M 24	30	–	92	138	105	104
250	PN 10	12 × M 20	26	27	71	110	–	82
250	PN 16	12 × M 24	26	48	85	131	–	98
250	PN 25	12 × M 27	32	–	134	200	–	150
300	PN 10	12 × M 20	26	34	81	125	–	94
300	PN 16	12 × M 24	28	67	118	179	–	134
300	PN 25	16 × M 27	34	–	138	204	–	153
350	PN 10	16 × M 20	26	47	118	188	–	112
350	PN 16	16 × M 24	30	68	165	254	–	152
350	PN 25	16 × M 30	–	–	252	380	–	227
400	PN 10	16 × M 24	26	65	167	260	–	151
400	PN 16	16 × M 27	32	95	215	330	–	193
400	PN 25	16 × M 33	–	–	326	488	–	289
450	PN 10	20 × M 24	28	59	133	235	–	153
450	PN 16	20 × M 27	40	96	196	300	–	198
450	PN 25	20 × M 33	–	–	253	385	–	256
500	PN 10	20 × M 24	28	66	171	265	–	155
500	PN 16	20 × M 30	34	132	300	448	–	275
500	PN 25	20 × M 33	–	–	360	533	–	317
600	PN 10	20 × M 27	28	93	219	345	–	206
600 *	PN 16	20 × M 33	36	202	443	658	–	415
600	PN 25	20 × M 36	–	–	516	731	–	431

* Designed acc. to EN 1092-1 (not to DIN 2501)

Promag S screw tightening torques for EN 1092-1, PN 10/16/25, stainless-steel; Calculated according to EN 1591-1:2014 for flange according to EN 1092-1:2013

Nominal diameter [mm]	EN (DIN) Pressure rating	Threaded fasteners	Flange thickness	Nom. tightening torque				
				Natural rubber [Nm]	Polyurethane [Nm]	PTFE [Nm]	PFA [Nm]	Hard rubber [Nm]
350	PN 10	16 × M 20	26	80	80	60	-	70
350	PN 16	16 × M 24	30	135	135	115	-	125
350	PN 25	16 × M 30	-	-	235	220	-	230
400	PN 10	16 × M 24	26	110	120	90	-	100
400	PN 16	16 × M 27	32	180	190	155	-	175
400	PN 25	16 × M 33	-	-	325	290	-	315
450	PN 10	20 × M 24	28	105	110	90	-	100
450	PN 16	20 × M 27	34	175	190	155	-	175
450	PN 25	20 × M 33	-	-	310	290	-	300
500	PN 10	20 × M 24	28	120	120	100	-	110
500	PN 16	20 × M 30	36	235	235	205	-	225
500	PN 25	20 × M 33	-	-	370	345	-	370
600	PN 10	20 × M 27	30	172	160	150	-	165
600 *	PN 16	20 × M 33	40	355	340	310	-	340
600	PN 25	20 × M 36	-	-	540	500	-	540

* Designed acc. to EN 1092-1 (not to DIN 2501)

Promag S screw tightening torques for ASME B16.5, Class 150/300

Promag S Nominal diameter [inch]	ASME Pressure rating	Threaded fasteners	Max. torque				
			Natural rubber [lbf · ft]	Polyurethane [lbf · ft]	PTFE [lbf · ft]	PFA [lbf · ft]	Hard rubber [lbf · ft]
½"	Class 150	4 × ½"	-	-	4.4	-	-
½"	Class 300	4 × ½"	-	-	4.4	-	-
1"	Class 150	4 × ½"	-	5.2	8.1	7.4	-
1"	Class 300	4 × 5/8"	-	5.9	10	8.9	-
1½"	Class 150	4 × ½"	-	7.4	18	15	-
1½"	Class 300	4 × ¾"	-	11	25	23	-
2"	Class 150	4 × 5/8"	-	16	35	32	26
2"	Class 300	8 × 5/8"	-	8.1	17	16	13
3"	Class 150	4 × 5/8"	15	32	58	49	44
3"	Class 300	8 × ¾"	-	19	35	31	28
4"	Class 150	8 × 5/8"	11	23	41	37	31
4"	Class 300	8 × ¾"	-	30	49	44	43
6"	Class 150	8 × ¾"	24	44	78	63	58
6"	Class 300	12 × ¾"	-	38	54	49	52
8"	Class 150	8 × ¾"	38	59	105	80	79
10"	Class 150	12 × 7/8"	42	55	100	-	75
12"	Class 150	12 × 7/8"	58	76	131	-	98
14"	Class 150	12 × 1"	77	117	192	-	100
16"	Class 150	16 × 1"	75	111	181	-	94
18"	Class 150	16 × 1 ⅛"	108	173	274	-	150
20"	Class 150	20 × 1 ⅛"	105	160	252	-	135
24"	Class 150	20 × 1 ¼"	161	226	352	-	198

Promag S screw tightening torques for JIS B2220, 10/20K

Promag S Nominal diameter [mm]	JIS Pressure rating	Threaded fasteners	Max. tightening torque				
			Natural rubber [Nm]	Polyurethane [Nm]	PTFE [Nm]	PFA [Nm]	Hard rubber [Nm]
15	10K	4 × M 12	-	-	16	-	-
15	20K	4 × M 12	-	-	16	-	-
25	10K	4 × M 16	-	19	32	27	-
25	20K	4 × M 16	-	19	32	27	-
32	10K	4 × M 16	-	22	38	-	-
32	20K	4 × M 16	-	22	38	-	-
40	10K	4 × M 16	-	24	41	37	-
40	20K	4 × M 16	-	24	41	37	-
50	10K	4 × M 16	-	33	54	46	40
50	20K	8 × M 16	-	17	27	23	20
65	10K	4 × M 16	18	45	74	63	55
65	20K	8 × M 16	-	23	37	31	28
80	10K	8 × M 16	10	23	38	32	29
80	20K	8 × M 20	-	35	57	46	42
100	10K	8 × M 16	12	29	47	38	35
100	20K	8 × M 20	-	48	75	58	56
125	10K	8 × M 20	20	51	80	66	60
125	20K	8 × M 22	-	79	121	103	91
150	10K	8 × M 20	25	63	99	81	75
150	20K	12 × M 22	-	72	108	72	81
200	10K	12 × M 20	23	52	82	54	61
200	20K	12 × M 22	-	80	121	88	91
250	10K	12 × M 22	39	87	133	-	100
250	20K	12 × M 24	-	144	212	-	159
300	10K	16 × M 22	38	63	99	-	74
300	20K	16 × M 24	-	124	183	-	138

Promag S screw tightening torques for JIS B2220, 10/20K

Nominal diameter [mm]	JIS Pressure rating	Threaded fasteners	Nom. tightening torque	
			Natural rubber [Nm]	Polyurethane [Nm]
350	10K	16 × M 22	109	109
350	20K	16 × M 30×3	217	217
400	10K	16 × M 24	163	163
400	20K	16 × M 30×3	258	258
450	10K	16 × M 24	155	155
450	20K	16 × M 30×3	272	272
500	10K	16 × M 24	183	183
500	20K	16 × M 30×3	315	315
600	10K	16 × M 30	235	235
600	20K	16 × M 36×3	381	381

Promag S screw tightening torques for AS 2129, Table E

Promag S Nominal diameter [mm]	AS 2129 Pressure rating	Threaded fasteners	Max. tightening torque	
			PTFE [Nm]	Natural rubber [Nm]
25	Table E	4 × M 12	21	–
50	Table E	4 × M 16	42	32
80	Table E	4 × M 16	–	16
100	Table E	8 × M 16	–	13
150	Table E	8 × M 20	–	22
200	Table E	8 × M 20	–	36
250	Table E	12 × M 20	–	37
300	Table E	12 × M 24	–	57
350	Table E	12 × M 24	–	85
400	Table E	12 × M 24	–	99
450	Table E	16 × M 24	–	96
500	Table E	16 × M 24	–	115
600	Table E	16 × M 30	–	199

Promag S screw tightening torques for AS 4087, PN 16

Promag S Nominal diameter [mm]	AS 4087 Pressure rating	Threaded fasteners	Max. tightening torque	
			PTFE [Nm]	Natural rubber [Nm]
50	PN 16	4 × M 16	42	32
80	PN 16	4 × M 16	–	16
100	PN 16	4 × M 16	–	13
150	PN 16	8 × M 16	–	20
200	PN 16	8 × M 16	–	33
250	PN 16	8 × M 20	–	64
300	PN 16	12 × M 20	–	55
350	PN 16	12 × M 24	–	91
400	PN 16	12 × M 24	–	113
450	PN 16	12 × M 24	–	144
500	PN 16	16 × M 24	–	131
600	PN 16	16 × M 27	–	204

Installing the high temperature version Promag S (with PFA lining)

The high temperature version has a housing support for the thermal separation of sensor and transmitter. The high temperature version is always used for applications in which high ambient temperatures are encountered *in conjunction with* high fluid temperatures. The high temperature version is obligatory if the fluid temperature exceeds +150 °C (+300 °F).



Note!

You will find information on permissible temperature ranges on → 105.

Insulation

Pipes generally have to be insulated if they carry very hot fluids, in order to avoid energy losses and to prevent accidental contact with pipes at temperatures that could cause injury. Guidelines regulating the insulation of pipes have to be taken into account.



Caution!

Risk of measuring electronics overheating. The housing support dissipates heat and its entire surface area must remain uncovered. Make sure that the sensor insulation does not extend past the top of the two sensor shells.

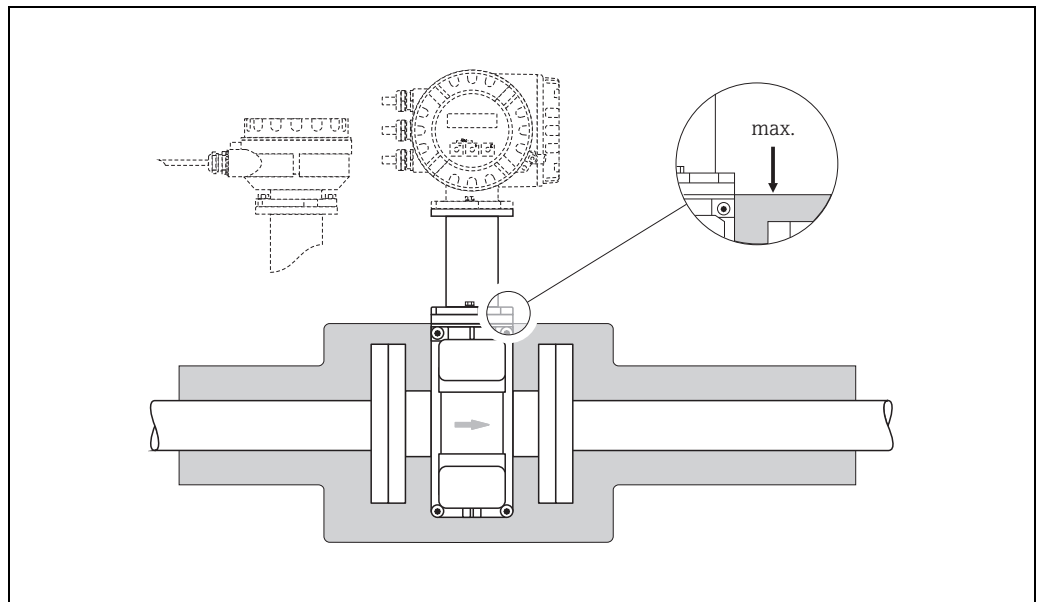

Fig. 19: Promag S (high temperature version): Insulating the pipe

a0004300

3.3.2 Installing the Promag H sensor

The Promag H is supplied to order, with or without pre-installed process connections. Pre-installed process connections are secured to the sensor with hex-head threaded fasteners.



Caution!

- The sensor might require support or additional attachments, depending on the application and the length of the piping run. When plastic process connections are used, the sensor must be additionally supported mechanically. A wall-mounting kit can be ordered separately from Endress+Hauser as an accessory → 82.

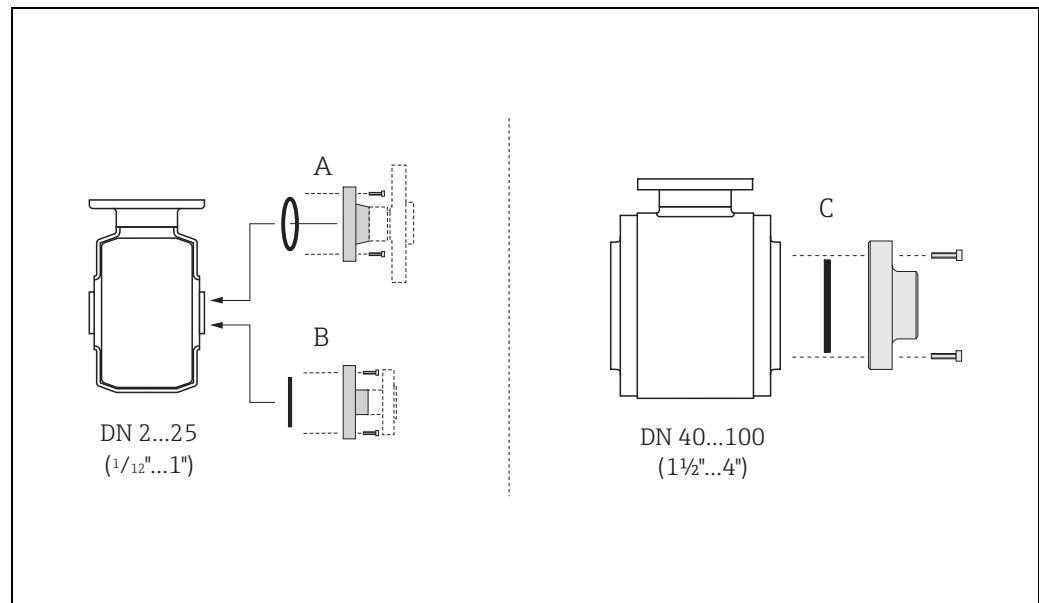

a0004301-en

Fig. 20: Promag H process connections

A: DN 2 to 25 ($\frac{1}{12}$ to 1") / process connections with O-rings:

Welding flanges (DIN EN ISO 1127, ODT / SMS), flange (EN (DIN), ASME, JIS), flange PVDF (EN (DIN), ASME, JIS), external and internal pipe threads, hose connection, PVC adhesive fitting

B: DN 2 to 25 ($\frac{1}{12}$ to 1") / process connections with aseptic gasket seals:

Weld nipples (EN 10357 (DIN 11850), ODT / SMS), Clamp (ISO 2852, DIN 32676, L14 AM7), coupling (DIN 11851, DIN 11864-1, SMS 1145), flange DIN 11864-2

C: DN 40 to 100 ($1\frac{1}{2}$ to 4") / process connections with aseptic gasket seals:

Weld nipples (EN 10357 (DIN 11850), ODT / SMS), Clamp (ISO 2852, DIN 32676), L14 AM7), coupling (DIN 11851, DIN 11864-1, ISO 2853, SMS 1145), flange DIN 11864-2

Seals

When installing the process connections, make sure that the seals are clean and correctly centered.



Caution!

- With metallic process connections, you must fully tighten the screws. The process connection forms a metallic connection with the sensor, which ensures a defined compression of the seal.
- With plastic process connections, note the max. torques for lubricated threads (7 Nm / 5.2 lbf ft). With plastic flanges, always use seals between connection and counter flange.
- The seals must be replaced periodically, depending on the application, particularly in the case of gasket seals (aseptic version)! The period between changes depends on the frequency of cleaning cycles, the cleaning temperature and the fluid temperature. Replacement seals can be ordered as accessories → 82.

Usage and assembly of ground rings (DN 2 to 25 / 1/12 to 1")

In case the process connections are made of plastic (e.g. flanges or adhesive fittings), the potential between the sensor and the fluid must be equalized using additional ground rings. If the ground rings are not installed this can affect the accuracy of the measurements or cause the destruction of the sensor through the electrochemical erosion of the electrodes.



Caution!

- Depending on the option ordered, plastic rings may be installed at the process connections instead of ground rings. These plastic rings serve only as spacers and have no potential equalization function. In addition, they provide a sealing function at the interface between the sensor and process connection. For this reason, with process connections without ground rings, these plastic rings/seals must not be removed, or must always be installed.
- Ground rings can be ordered separately from Endress+Hauser as accessories → 82. When placing the order, make certain that the ground ring is compatible with the material used for the electrodes. Otherwise, there is a risk that the electrodes may be destroyed by electrochemical corrosion! Information about the materials can be found on → 111.
- Ground rings, including the seals, are mounted within the process connections. Therefore, the fitting length is not affected.

1. Loosen the four or six hexagonal headed bolts (1) and remove the process connection from the sensor (4).
2. Remove the plastic ring (3), including the two O-ring seals (2).
3. Place one seal (2) in the groove of the process connection.
4. Place the metal ground ring (3) on the process connection.
5. Now place the second seal (2) in the groove of the ground ring.
6. Finally, mount the process connection on the sensor again. With plastic process connections, note the max. torques for lubricated threads (7 Nm / 5.2 lbf ft).

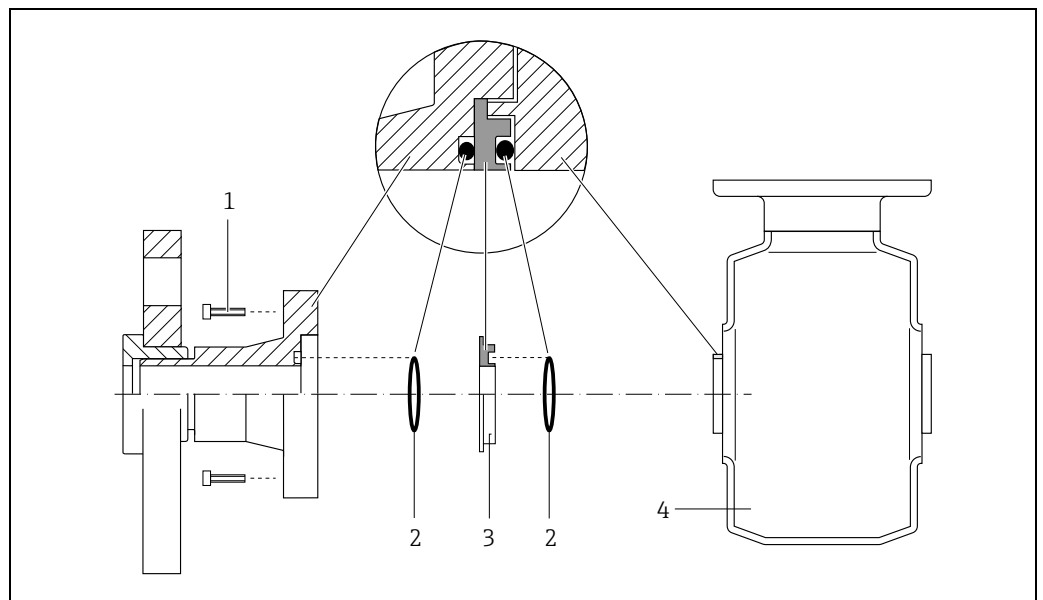

Fig. 21: Installing ground rings with a Promag H (DN 2 to 25 / 1/12 to 1")

- | | |
|---|---|
| 1 | Hexagonal headed bolts (process connection) |
| 2 | O-ring seals |
| 3 | Ground ring or plastic ring (placeholder) |
| 4 | Sensor |

Welding the sensor into the piping (weld nipples)



Caution!

Risk of destroying the measuring electronics. Make sure that the welding machine is not grounded via the sensor or the transmitter.

1. Tack-weld the Promag H sensor into the pipe. A suitable welding jig can be ordered separately from Endress+Hauser as an accessory → 82.
1. Remove the threaded fasteners from the process-connection flange. Remove the sensor complete with seal from the pipe.
2. Weld the process connection to the pipe.
3. Reinstall the sensor in the pipe. Make sure that everything is clean and that the seal is correctly seated.



Note!

- If thin-walled foodstuffs pipes are not welded correctly, the heat could damage the installed seal. It is therefore advisable to remove the sensor and the seal prior to welding.
- The pipe has to be spread approximately 8 mm to permit disassembly.

Cleaning with pigs

If pigs are used for cleaning, it is essential to take the inside diameters of measuring tube and process connection into account. All the dimensions and lengths of the sensor and transmitter are provided in the separate documentation "Technical Information".

3.3.3 Turning the transmitter housing

Turning the aluminum field housing

1. Loosen the two securing screws.
2. Turn the bayonet catch as far as it will go.
3. Carefully lift the transmitter housing as far as it will go.
4. Turn the transmitter housing to the desired position (max. $2 \times 90^\circ$ in either direction).
5. Lower the housing into position and reengage the bayonet catch.
6. Retighten the two securing screws.

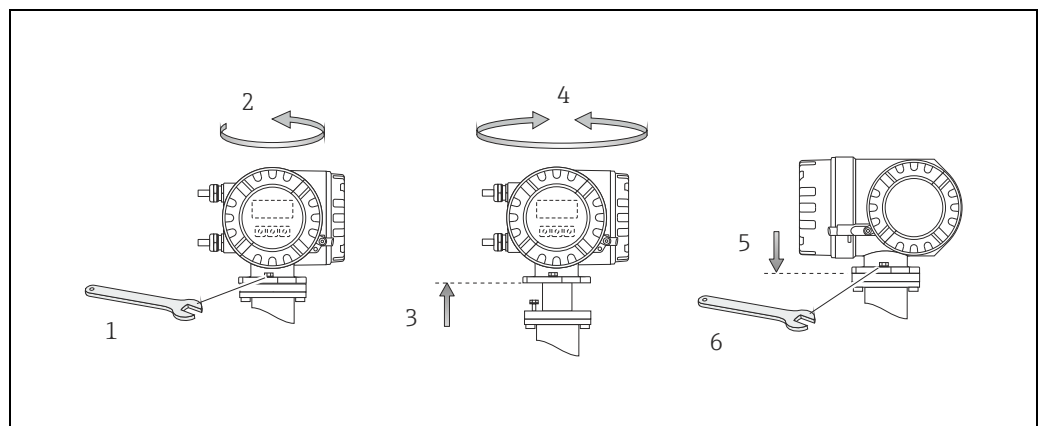

Fig. 22: Turning the transmitter housing (aluminum field housing)

a0004302

Turning the stainless-steel field housing

- Loosen the two securing screws.
- Carefully lift the transmitter housing as far as it will go.
- Turn the transmitter housing to the desired position (max. $2 \times 90^\circ$ in either direction).
- Lower the housing into position.
- Retighten the two securing screws.

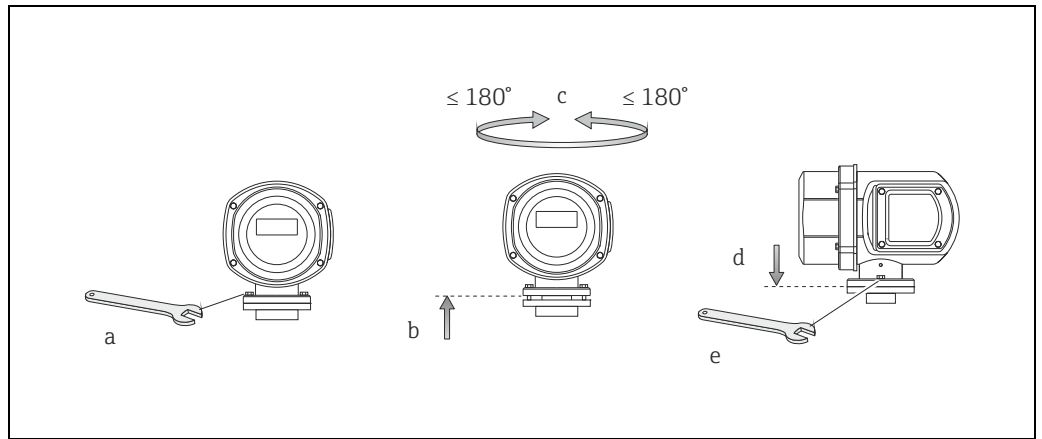

Fig. 23: Turning the transmitter housing (stainless-steel field housing)

3.3.4 Turning the local display

Turning the stainless-steel field housing

- Unscrew the electronics compartment cover from the transmitter housing.
- Press the latches on the side of the display module and pull the module out of the electronics compartment cover.
- Turn the display to the desired position (max. $4 \times 45^\circ$ in both directions) and position it back on the electronics compartment cover.
- Screw the cover of the electronics compartment firmly onto the transmitter housing.

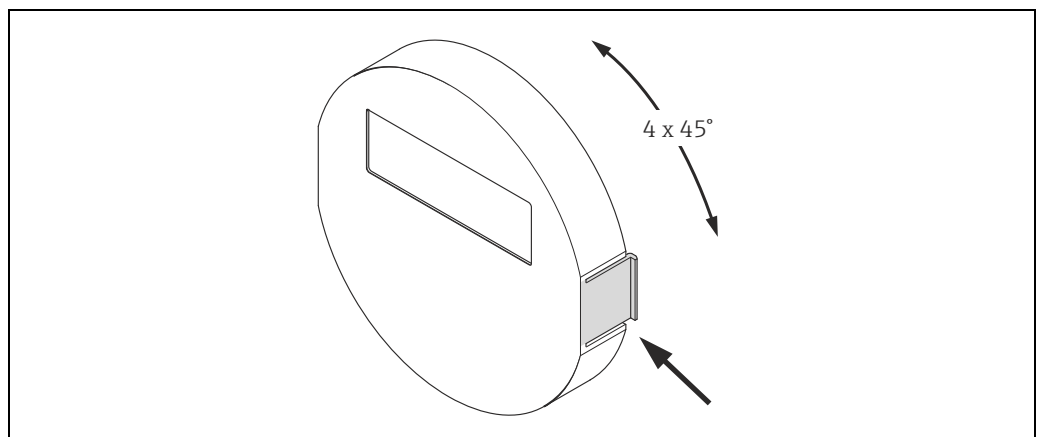

Fig. 24: Turning the local display (field housing)

3.3.5 Installing the wall-mount housing

There are various ways of installing the wall-mount transmitter housing:

- Mounted directly on the wall
- Installation in control panel (with separate mounting kit, accessories) → 31
- Pipe mounting (with separate mounting kit, accessories) → 31



Caution!

- Make sure that the permitted ambient temperature range is observed (see nameplate or → 104). Install the device at a shady location. Avoid direct sunlight.
- Always install the wall-mount housing in such a way that the cable entries are pointing down.

Mounted directly on the wall

1. Drill the holes as illustrated.
2. Remove the cover of the connection compartment (a).
3. Push the two securing screws (b) through the appropriate bores (c) in the housing.
 - Securing screws (M6): max. \varnothing 6.5 mm (0.26)
 - Screw head: max. \varnothing 10.5 mm (0.4")
4. Secure the transmitter housing to the wall as indicated.
5. Screw the cover of the connection compartment (a) firmly onto the housing.

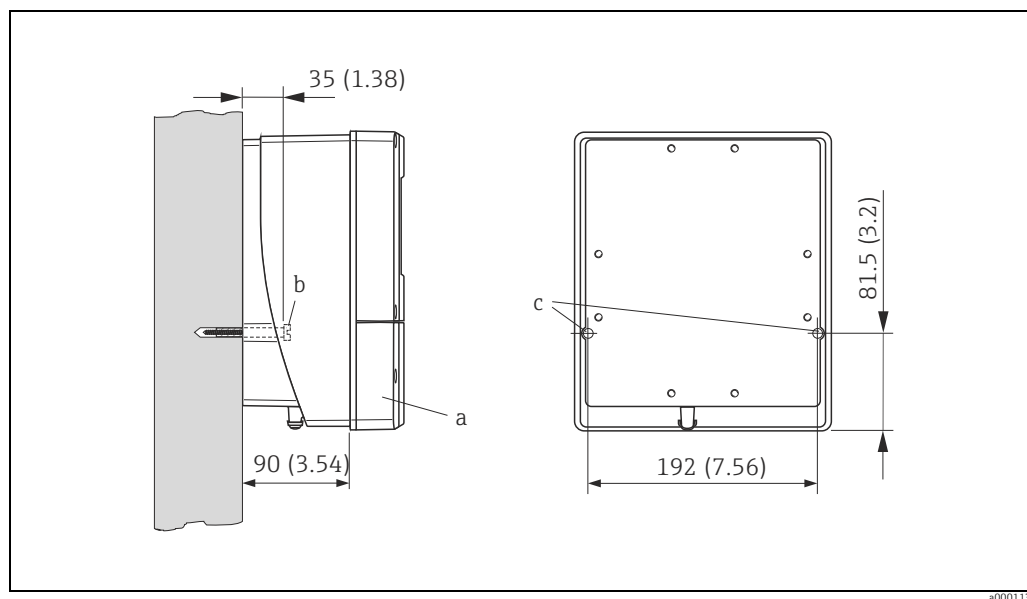

Fig. 25: Mounted directly on the wall. Engineering unit mm (in)

Installation in control panel

1. Prepare the opening in the panel as illustrated.
2. Slide the housing into the opening in the panel from the front.
3. Screw the fasteners onto the wall-mount housing.
4. Place the threaded rods in the fasteners and screw them down until the housing is seated tightly against the panel. Afterwards, tighten the locking nuts. Additional support is not necessary.

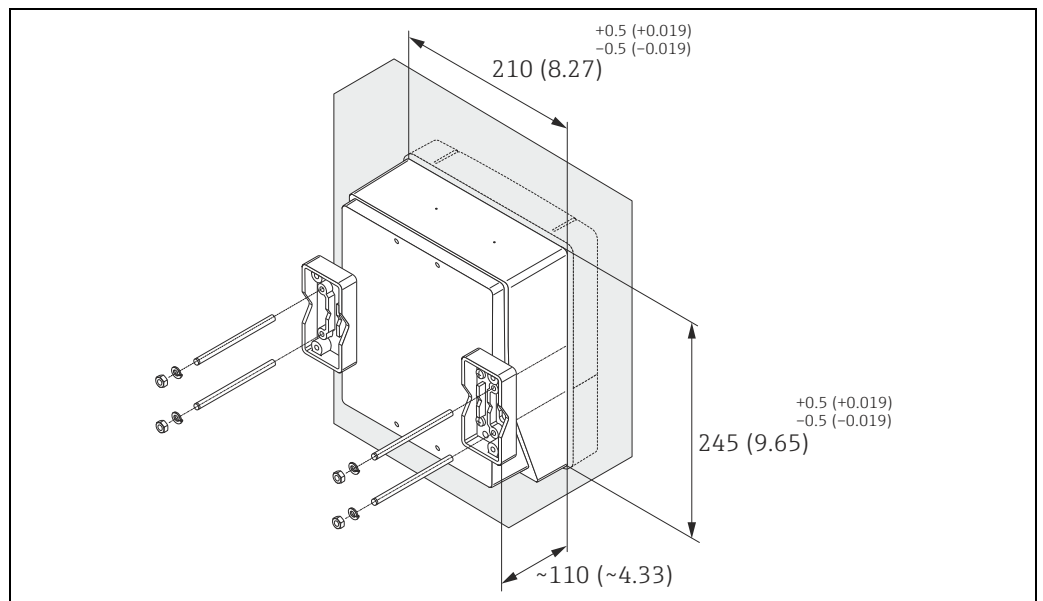

Fig. 26: Panel Installation (wall-mount housing). Engineering unit mm (in)

Pipe mounting

The assembly should be performed by following the instructions in the following diagram.



Caution!

If the device is mounted to a warm pipe, make sure that the housing temperature does not exceed +60 °C (+140 °F), which is the maximum permissible temperature.

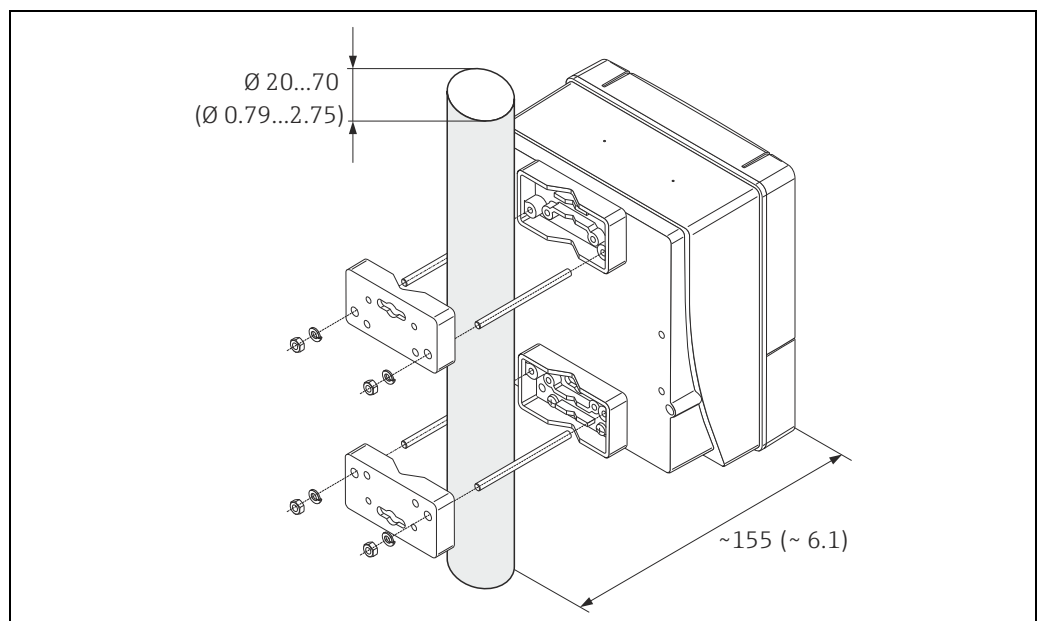

Fig. 27: Pipe mounting (wall-mount housing). Engineering unit mm (in)

3.4 Post-installation check

Perform the following checks after installing the measuring device in the pipe:

Device condition/specifications	Notes
Is the device damaged (visual inspection)?	-
Does the device correspond to specifications at the measuring point, including process temperature and pressure, ambient temperature, minimum fluid conductivity, measuring range, etc.?	→ 101
Installation	Notes
Does the arrow on the sensor nameplate match the direction of flow through the pipe?	-
Is the position of the measuring electrode plane correct?	→ 14
Is the position of the empty pipe detection electrode correct?	→ 14
Were all threaded fasteners tightened to the specified torques when the sensor was installed?	→ 20
Were the correct seals installed (type, material, installation)?	→ 20
Are the measuring-point number and labelling correct (visual inspection)?	-
Process environment / process conditions	Notes
Are the inlet and outlet runs respected?	Inlet run $\geq 5 \times \text{DN}$ Outlet run $\geq 2 \times \text{DN}$
Is the measuring device protected against moisture and direct sunlight?	-
Is the sensor adequately protected against vibration (attachment, support)?	Acceleration up to 2 g by analogy with IEC 600 68-2-6 → 104

4 Wiring



Warning!

- When connecting Ex-certified devices, see the notes and diagrams in the Ex-specific supplement to these Operating Instructions. Please do not hesitate to contact your Endress+Hauser sales office if you have any questions.
- If you use remote versions, connect each sensor *only* to the transmitter having the same serial number. Measuring errors can occur if the devices are not connected in this way.



Note!

The device does not have an internal power switch. For this reason, assign the device a switch or power-circuit breaker which can be used to disconnect the power supply line from the power grid.

4.1 Connecting the remote version

4.1.1 Connecting the sensor



Warning!

- Risk of electric shock. Switch off the power supply before opening the device. Do not install or wire the device while it is connected to the power supply. Failure to comply with this precaution can result in irreparable damage to the electronics.
- Risk of electric shock. Connect the protective conductor to the ground terminal on the housing before the power supply is applied.





Procedure (→  28, →  29):

1. Transmitter: Loosen the screws and remove the cover (a) from the connection compartment.
2. Sensor: Remove the cover (b) from the connection housing.
3. Feed the electrode cable (c) and coil current cable (d) through the appropriate cable entries.



Caution!

- Make sure the connecting cables are secured →  19.
- Risk of damaging the coil driver. Do not connect or remove the coil current cable until the power supply has been switched off.

4. Terminate electrode cable and coil current cable →  35, →  36
5. Establish the connections between the sensor and transmitter in accordance with the wiring diagram:
 -  28, →  29
 - wiring diagram inside the cover



Note!

The cable shields of the Promag H sensor are grounded using strain relief clamps (please refer to cable termination →  36).



Caution!

Insulate the cable shields that are not connected. This eliminates the risk of short-circuits with neighboring cable shields inside the sensor connection housing.

6. Transmitter: Secure the cover (a) on the connection compartment.
7. Sensor: Secure the lid (b) to the connection housing.

Promag S

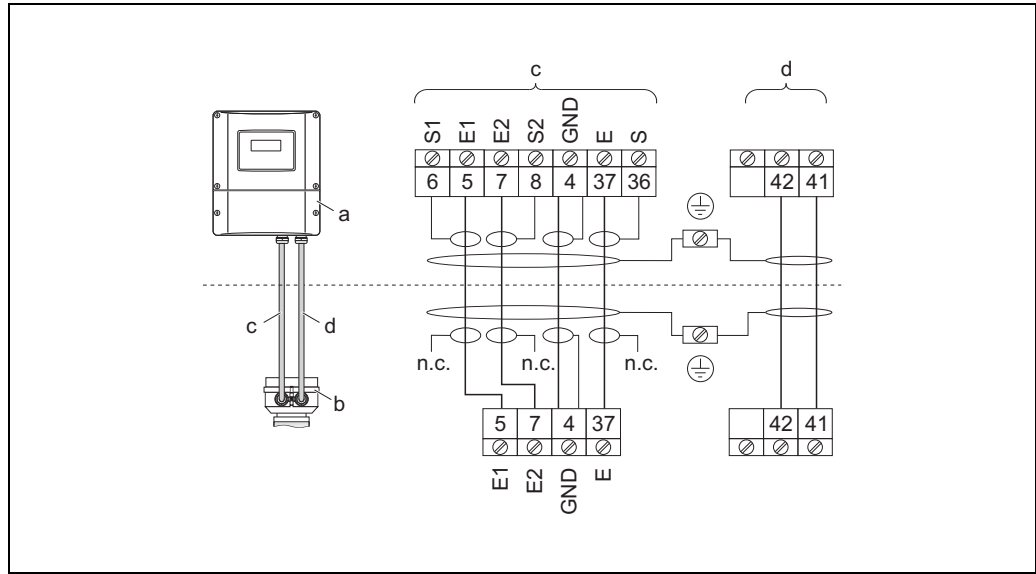

A0011722

Fig. 28: Connecting the remote version of Promag S

- a Connection compartment, wall-mount housing
 - b Cover of connection housing, sensor
 - c Electrode cable
 - d Coil current cable
 - n.c. unconnected, insulated cable shields
- Terminal no. and cable colours: 6/5 = brown; 7/8 = white; 4 = green; 36/37 = yellow

Promag H

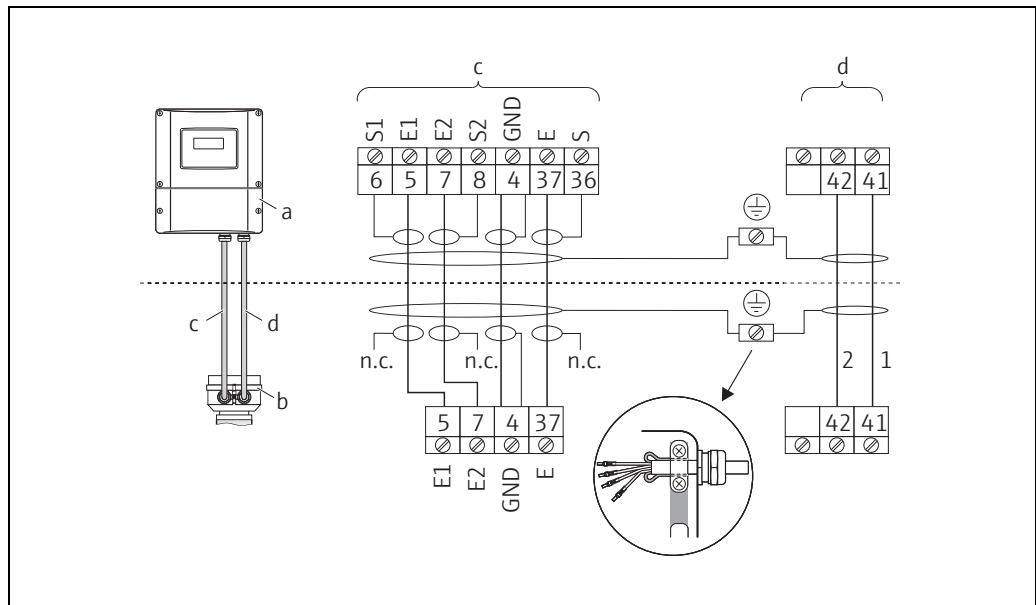

A0011747

Fig. 29: Connecting the remote version of Promag H

- a Connection compartment, wall-mount housing
 - b Cover of connection housing, sensor
 - c Electrode cable
 - d Coil current cable
 - n.c. unconnected, insulated cable shields
- Terminal no. and cable colors: 6/5 = brown; 7/8 = white; 4 = green; 36/37 = yellow

**Cable termination in remote version
Promag S**

Terminate the signal and coil current cables as shown in the figure below (Detail A).
Fit the fine-wire cores with wire end ferrules (Detail B).

Caution!

When fitting the connectors, pay attention to the following points:

- *Electrode cable* → Make sure that the wire end ferrules do not touch the wire shields on the sensor side.
Minimum distance = 1 mm / 0.04" (exception "GND" = green cable).
- *Coil current cable* → Insulate one core of the three-core wire at the level of the core reinforcement; you only require two cores for the connection.

TRANSMITTER

Electrode cable

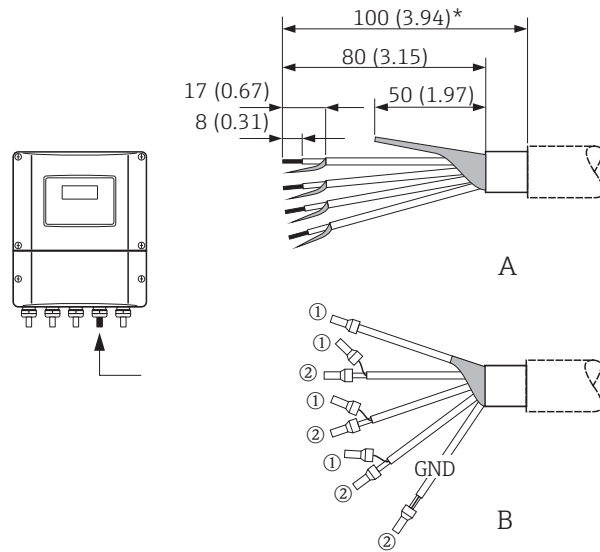

Fig. 30: Engineering unit mm (in)

a0002687

Coil current cable

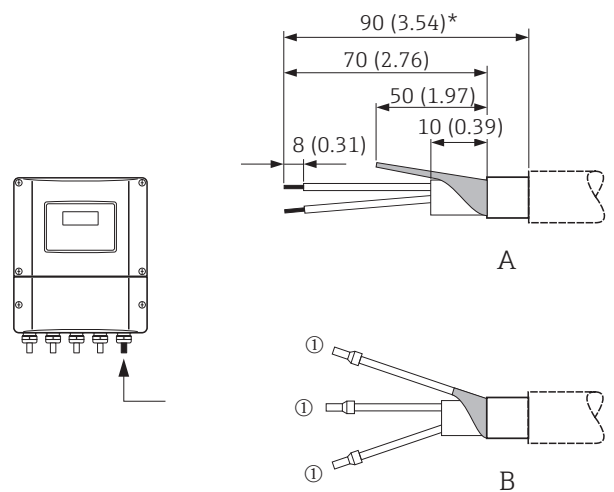

Fig. 31: Engineering unit mm (in)

a0002688

SENSOR

Electrode cable

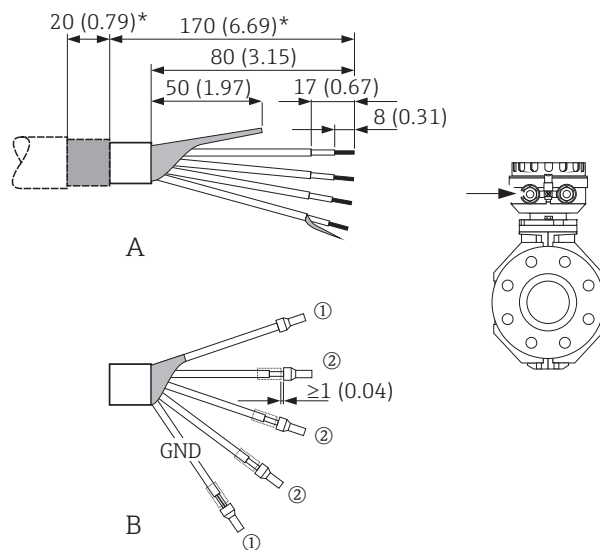

Fig. 32: Engineering unit mm (in)

a0002646

Coil current cable

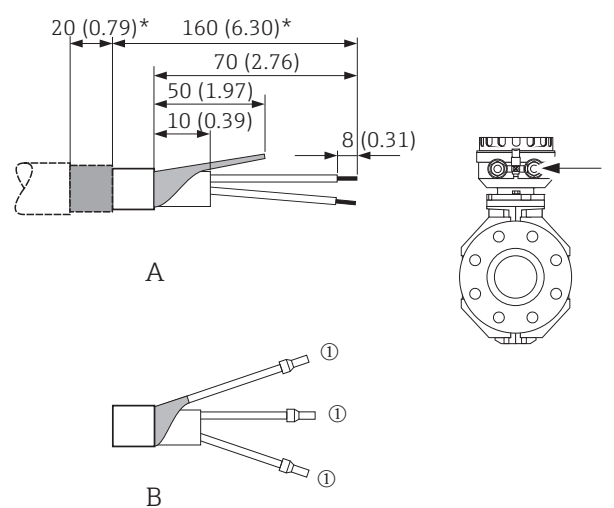

Fig. 33: Engineering unit mm (in)

a0002650

- ① = Cable end sleeve red, Ø 1.0 mm (0.04 in)
- ② = Cable end sleeve white, Ø 0.5 mm (0.02 in)
- * = Stripping for armored cables only

**Cable termination in remote version
Promag H**

Terminate the signal and coil current cables as shown in the figure below (Detail A).
Fit the fine-wire cores with wire end ferrules (Detail B).

Caution!

When fitting the connectors, pay attention to the following points:

- **Electrode cable** → Make sure that the wire end ferrules do not touch the wire shields on the sensor side.
Minimum distance = 1 mm / 0.04" (exception "GND" = green cable).
- **Coil current cable** → Insulate one core of the three-core wire at the level of the core reinforcement; you only require two cores for the connection.
- On the sensor side, reverse both cable shields approx. 15 mm over the outer jacket. The strain relief ensures an electrical connection with the connection housing.

TRANSMITTER

Electrode cable

Coil current cable

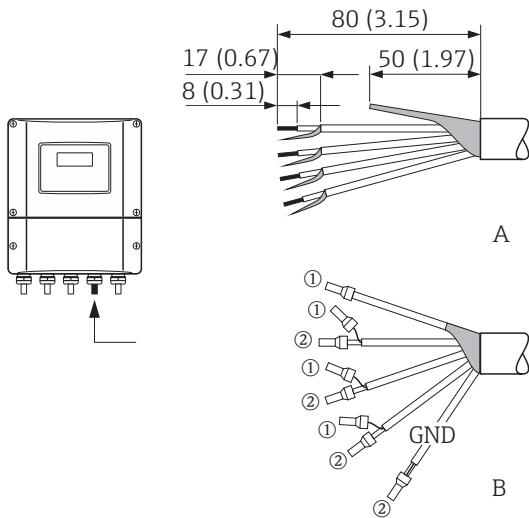

Fig. 34: Engineering unit mm (in)

a0002686

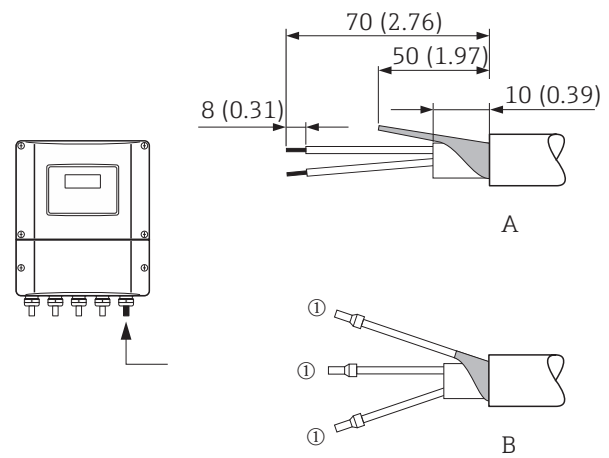

Fig. 35: Engineering unit mm (in)

a0002684

SENSOR

Electrode cable

Coil current cable

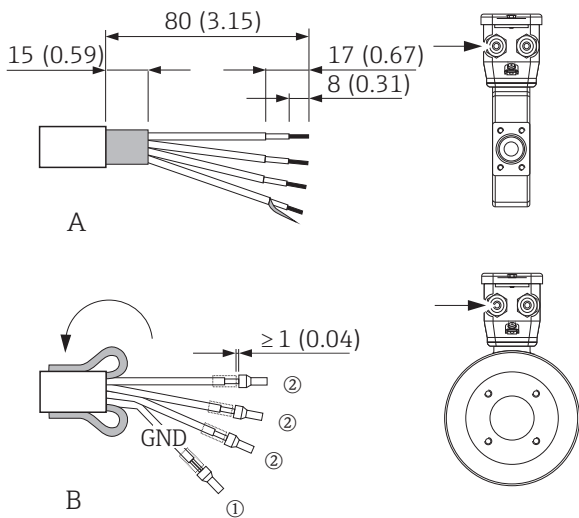

Fig. 36: Engineering unit mm (in)

a0002647

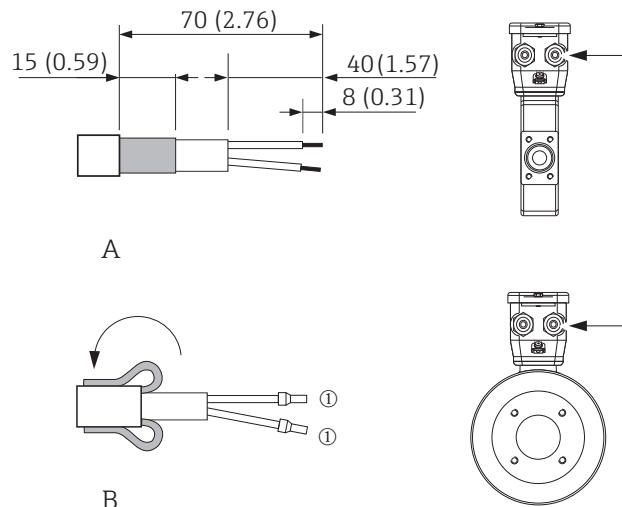

Fig. 37: Engineering unit mm (in)

a0002648

- ① = Cable end sleeve red, Ø 1.0 mm (0.04 in)
- ② = Cable end sleeve white, Ø 0.5 mm (0.02 in)
- * = Stripping for armored cables only

4.1.2 Cable specifications

Coil current cable

- $3 \times 0.75 \text{ mm}^2$ (18 AWG) PVC cable with common, braided copper shield ($\varnothing \sim 9 \text{ mm}/0.35''$)
- Conductor resistance: $\leq 37 \text{ } \Omega/\text{km}$ ($\leq 0.011 \text{ } \Omega/\text{ft}$)
- Capacitance: core/core, shield grounded: $\leq 120 \text{ pF/m}$ ($\leq 37 \text{ pF/ft}$)
- Operating temperature:
 - Cable not permanently routed: -20 to $+80 \text{ } ^\circ\text{C}$ (-4 to $+176 \text{ } ^\circ\text{F}$)
 - Cable permanently routed: -40 to $+80 \text{ } ^\circ\text{C}$ (-40 to $+176 \text{ } ^\circ\text{F}$)
- Cable cross-section: max. 2.5 mm^2 (14 AWG)

Electrode cable

- $3 \times 0.38 \text{ mm}^2$ (20 AWG) PVC cable with common, braided copper shield ($\varnothing \sim 9.5 \text{ mm}/0.37''$) and individually shielded cores
- With Empty Pipe Detection (EPD): $4 \times 0.38 \text{ mm}^2$ (20 AWG) PVC cable with common, braided copper shield ($\varnothing \sim 9.5 \text{ mm}/0.37''$) and individually shielded cores
- Conductor resistance: $\leq 50 \text{ } \Omega/\text{km}$ ($\leq 0.015 \text{ } \Omega/\text{ft}$)
- Capacitance: core/shield: $\leq 420 \text{ pF/m}$ ($\leq 128 \text{ pF/ft}$)
- Operating temperature:
 - Cable not permanently routed: -20 to $+80 \text{ } ^\circ\text{C}$ (-4 to $+176 \text{ } ^\circ\text{F}$)
 - Cable permanently routed: -40 to $+80 \text{ } ^\circ\text{C}$ (-40 to $+176 \text{ } ^\circ\text{F}$)
- Cable cross-section: max. 2.5 mm^2 (14 AWG)

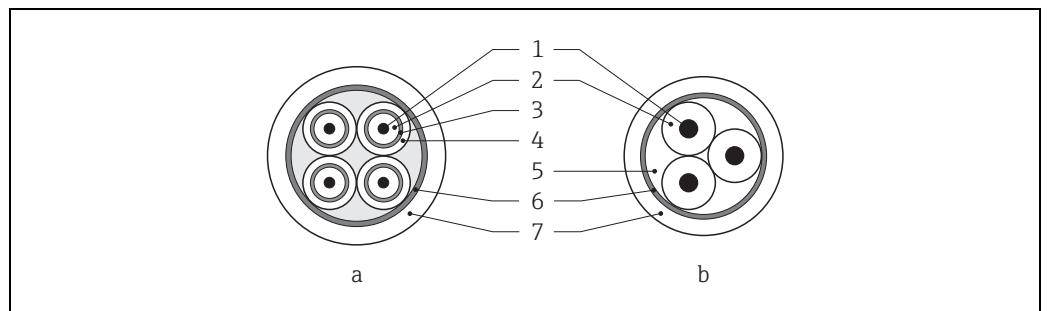

Fig. 38: Cable cross-section

- | | |
|---|--------------------|
| a | Electrode cable |
| b | Coil current cable |
| 1 | Core |
| 2 | Core insulation |
| 3 | Core shield |
| 4 | Core jacket |
| 5 | Core reinforcement |
| 6 | Cable shield |
| 7 | Outer jacket |

Reinforced connecting cables

As an option, Endress+Hauser can also deliver reinforced connecting cables with an additional, reinforcing metal braid. We recommend such cables for the following cases:

- Directly buried cable
- Cables endangered by rodents
- Device operation which should comply with the IP 68 (NEMA 6P) standard of protection

Operation in zones of severe electrical interference

The measuring device complies with the general safety requirements in accordance with EN 61010-1, the EMC requirements of IEC/EN 61326 and NAMUR recommendation NE 21.



Caution!

Grounding of the shield is by means of the ground terminals provided for the purpose inside the connection housing. Keep the stripped and twisted lengths of cable shield to the terminals as short as possible.

4.2 Connecting the measuring unit

4.2.1 Connecting the transmitter



Warning!

- Risk of electric shock. Switch off the power supply before opening the device. Do not install or wire the device while it is connected to the power supply. Failure to comply with this precaution can result in irreparable damage to the electronics.
- Risk of electric shock. Connect the protective earth to the ground terminal on the housing before the power supply is applied (e.g. galvanically isolated power supply SELV or PELV).
- Compare the specifications on the nameplate with the local voltage supply and frequency. Also observe the national regulations governing the installation of electrical equipment.

1. Unscrew the connection compartment cover (f) from the transmitter housing.
2. Feed the power supply cable (a) and electrode cables (b) through the appropriate cable entries.
3. Establish the connections:
 - Wiring diagram (aluminum housing) → 39
 - Wiring diagram (stainless steel field housing) → 40
 - Wiring diagram (wall-mount housing) → 41
 - Terminal assignment → 40
4. Screw the cover of the connection compartment (f) back onto the transmitter housing.

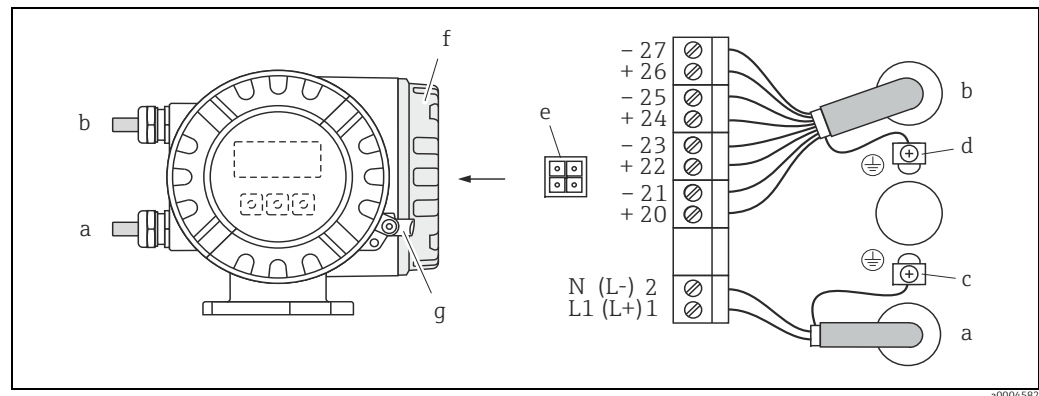

Fig. 39: Connecting the transmitter (aluminum field housing). Cable cross-section: max. 2.5 mm² (14 AWG)

- a Cable for power supply
Terminal **No. 1**: L1 for AC, L+ for DC
Terminal **No. 2**: N for AC, L- for DC
- b Electrode cable: Terminals **Nos. 20–27** → 40
- c Ground terminal for protective conductor
- d Ground terminal for electrode cable shield
- e Service adapter for connecting service interface FXA193 (Fieldcheck, FieldCare)
- f Connection compartment cover
- g Securing clamp

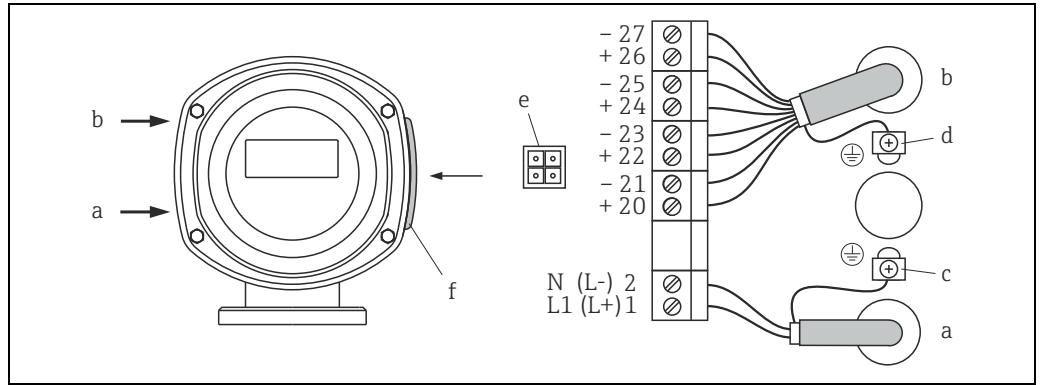

Fig. 40: Connecting the transmitter (stainless steel field housing). Cable cross-section: max. 2.5 mm² (14 AWG)

- a Cable for power supply
Terminal No. 1: L1 for AC, L+ for DC
Terminal No. 2: N for AC, L- for DC
- b Electrode cable: Terminals Nos. 20–27 → 40
- c Ground terminal for protective conductor
- d Ground terminal for electrode cable shield
- e Service adapter for connecting service interface FXA193 (Fieldcheck, FieldCare)
- f Connection compartment cover
- g Securing clamp

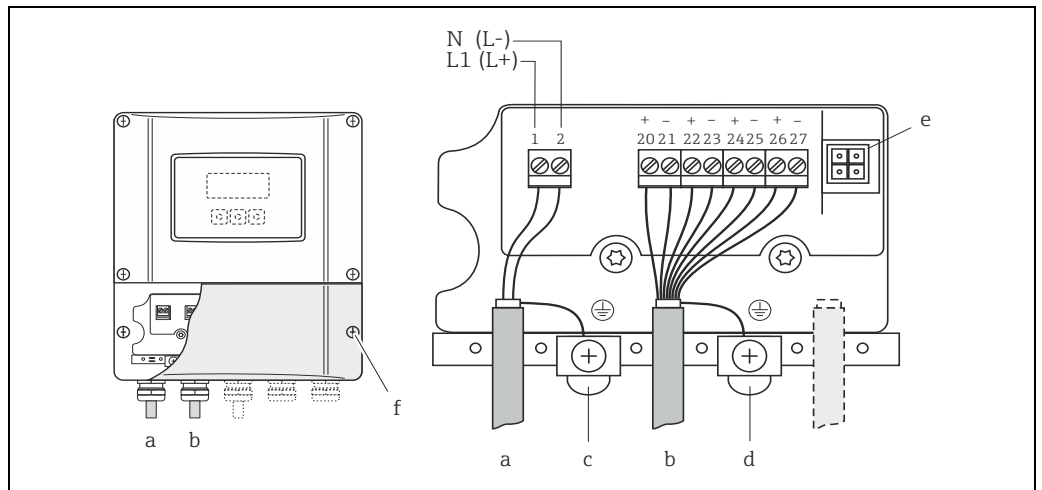



Fig. 41: Connecting the transmitter (wall-mount housing); cable cross-section: max. 2.5 mm² (14 AWG)

- a Cable for power supply
Terminal No. 1: L1 for AC, L+ for DC
Terminal No. 2: N for AC, L- for DC
- b Electrode cable: Terminals Nos. 20–27 → 40
- c Ground terminal for protective conductor
- d Ground terminal for electrode cable shield
- e Service adapter for connecting service interface FXA193 (Fieldcheck, FieldCare)
- f Connection compartment cover

4.2.2 Terminal assignment

Electrical values of inputs →  101

Electrical values of outputs →  101

Order code for "Input / Output"	Terminal No.			
	20 (+) / 21 (-)	22 (+) / 23 (-)	24 (+) / 25 (-)	26 (+) / 27 (-)
<i>Fixed communication boards (fixed assignment)</i>				
A	-	-	Frequency output	Current output HART
B	Relay output 2	Relay output 1	Frequency output	Current output HART
<i>Flexible communication boards</i>				
C	Relay output 2	Relay output 1	Frequency output	Current output HART
D	Status input	Relay output	Frequency output	Current output HART
L	Status input	Relay output 2	Relay output 1	Current output HART
M	Status input	Frequency output 2	Frequency output 1	Current output HART
2	Relay output	Current output 2	Frequency output	Current output 1 HART
3	Current input	Current output 2	Frequency output	Current output HART
4	Current input	Relay output	Frequency output	Current output HART
5	Status input	Current input	Frequency output	Current output HART

4.2.3 HART connection

Users have the following connection options at their disposal:

- Direct connection to transmitter by means of terminals 26(+) and 27 (-)
- Connection by means of the 4 to 20 mA circuit.
- The measuring loop's minimum load must be at least 250 Ω.
- After commissioning, make the following settings:
 - CURRENT SPAN function → "4-20 mA HART"
 - Switch HART write protection on or off → 63

Connection of the HART handheld communicator

See also the documentation issued by the HART Communication Foundation, and in particular HCF LIT 20: "HART, a technical summary".

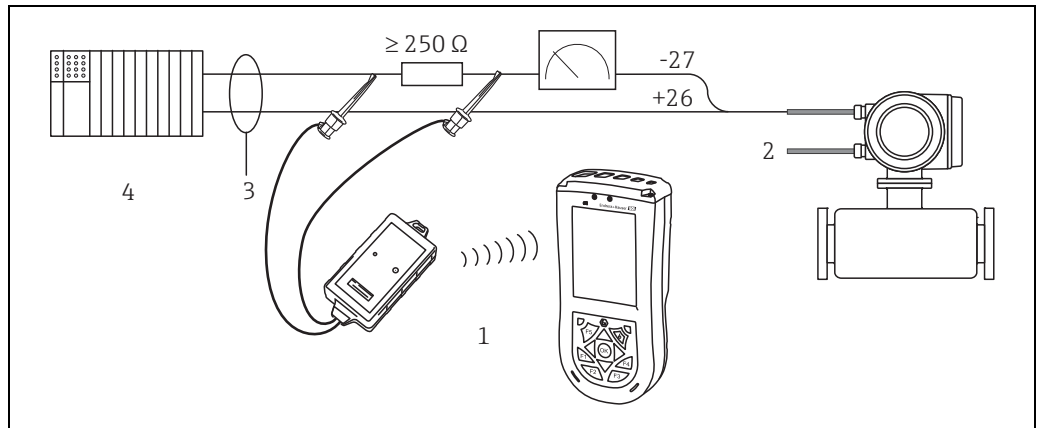

Fig. 42: Electrical connection of HART handheld Field Xpert SFX100

1 = HART handheld Field Xpert SFX100, 2 = Auxiliary energy, 3 = Shielding, 4 = Other devices or PLC with passive input

Connection of a PC with an operating software

In order to connect a PC with operating software (e.g. "FieldCare"), a HART modem (e.g. "Commubox FXA195") is needed.

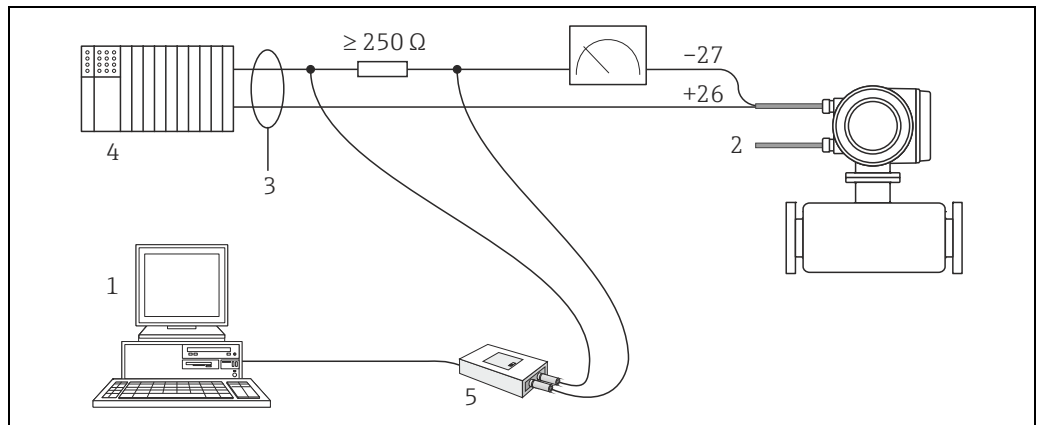

Fig. 43: Electrical connection of a PC with operating software

1 = PC with operating software, 2 = Auxiliary energy, 3 = Shielding, 4 = Other devices or PLC with passive input, 5 = HART modem, e.g. Commubox FXA195

4.3 Potential equalization



Warning!

The potential equalization has to involve the measuring system.

Proper measurement is only ensured when the medium and the sensor have the same electrical potential. Most Promag sensors have a reference electrode installed as standard, which guarantees the required potential equalization.

The following must also be taken into account for potential equalization:

- Company-internal grounding guidelines
- Operating conditions such as material/grounding of piping etc. (see table)

4.3.1 Potential equalization, Promag S

- Reference electrode is standard for electrode material 1.4435 (316L), Alloy C-22, tantalum, titanium Gr. 2, Duplex 1.4462, tungsten carbide coating (for electrodes made of 1.4435)
- Reference electrode is optional for electrode made of platinum
- Reference electrode not present in measuring tubes with a natural rubber lining in conjunction with brush electrodes.



Caution!

- For sensors without reference electrodes or without metal process connections, carry out potential equalization as per the instructions for special cases → 42. These special measures are particularly important when standard grounding measures cannot be applied or extreme equalizing currents are expected.
- Sensors with brush electrodes do not have a reference electrode. For this reason, ground disks need to be installed in some cases to ensure sufficient potential equalization to the fluid. This applies in particular to isolating lined pipes which are not grounded → 42.

4.3.2 Potential equalization, Promag H

- No reference electrode available!

The metallic process connection always establishes an electrical connection to the fluid.



Caution!

When using process connections made of plastic, potential equalization must be guaranteed through the use of grounding rings → 27.

The necessary grounding rings may be ordered separately as an accessory from Endress+Hauser (→ 82).

4.3.3 Connection examples for potential equalization

Standard case

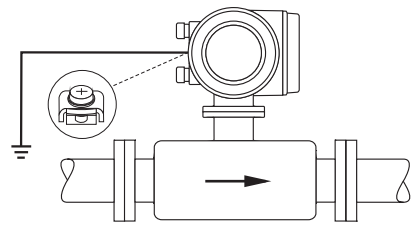
Operating conditions	Potential equalization
<p>When using the measuring device in:</p> <ul style="list-style-type: none"> ■ metallic, grounded piping <p>Potential equalization is carried out via the ground terminal of the transmitter.</p> <p> Note! For installation in metal pipes, it is advisable to connect the ground terminal of the transmitter housing to the piping.</p>	 <p style="text-align: right; font-size: small;">A0011892</p> <p>Fig. 44: Via the transmitter's ground terminal</p>

Special cases

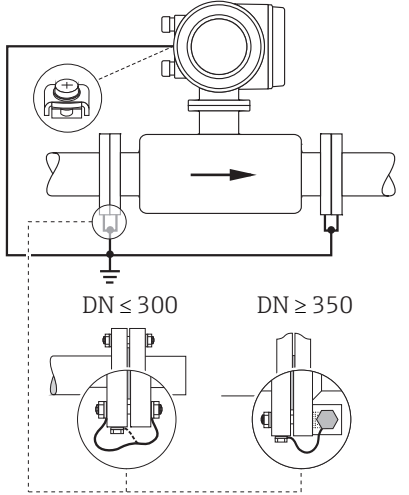
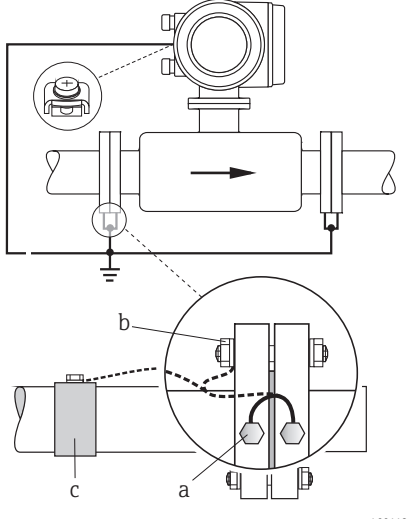
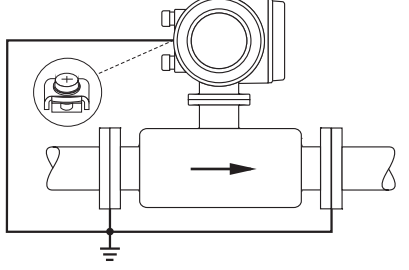
Operating conditions	Potential equalization
<p>When using the measuring device in:</p> <ul style="list-style-type: none"> ▪ Metallic, ungrounded piping <p>This type of connection occurs when:</p> <ul style="list-style-type: none"> ▪ The usual potential equalization cannot be guaranteed ▪ Extremely high equalizing currents are expected <p>A ground cable (copper wire, at least 6 mm² (0.0093 in²)) is used to connect both sensor flanges to the respective pipe flange and to ground them. Connect the transmitter or sensor connection housing, as applicable, to ground potential by means of the ground terminal provided for this purpose.</p> <p>The installation of the ground cable depends on the nominal diameter:</p> <ul style="list-style-type: none"> ▪ DN ≤ 300 (12"): The ground cable is in direct connection with the conductive flange coating and is secured by the flange screws. ▪ DN ≥ 350 (14"): The ground cable connects directly to the metal transport bracket. <p> Note! The ground cable for flange-to-flange connections can be ordered separately as an accessory from Endress+Hauser.</p>	 <p style="text-align: right;">A0011893</p> <p>Fig. 45: Via the transmitter's ground terminal and the pipe flanges</p>
<p>Version with pre-installed ground cable for DN ≤ 300 (12") (order option)</p> <p>Ground cables (copper wire, min. 6 mm² (0.0093 in²)), which are pre-installed on the sensor flange, are also optionally available. These ground cables can be secured and connected electrically to the piping in different ways:</p> <ul style="list-style-type: none"> ▪ Using a screw on the side of the pipe flange (a) ▪ Using the flange screws (b) ▪ Using a pipe clip installed around the pipe (c) 	 <p style="text-align: right;">A0011897</p> <p>Fig. 46: Possibilities for connecting and securing preinstalled ground cables</p>
<p>When using the measuring device in:</p> <ul style="list-style-type: none"> ▪ Plastic pipes ▪ Isolating lined pipes <p>This type of connection occurs when:</p> <ul style="list-style-type: none"> ▪ The usual potential equalization cannot be guaranteed ▪ Extremely high equalizing currents are expected <p>Potential equalization takes place using additional ground disks, which are connected to the ground terminal via a ground cable (copper wire, min. 6 mm² (0.0093 in²)). When installing the ground disks, please comply with the enclosed Installation Instructions.</p>	 <p style="text-align: right;">A0011895</p> <p>Fig. 47: Via the transmitter's ground terminal and the optionally available ground disks</p>

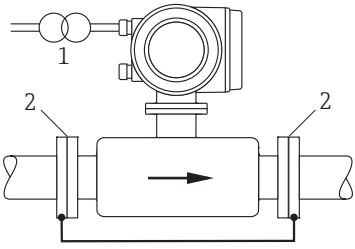
Operating conditions	Potential equalization
<p>When using the measuring device in:</p> <ul style="list-style-type: none"> ▪ Pipes with cathodic protection <p>The device is installed in the pipeline in such a way that it is potential-free.</p> <p>Using a ground cable (copper wire, min. 6 mm² (0.0093 in²)), only the two pipe flanges are connected. When doing so, the ground cable is mounted directly on the conductive flange coating using flange screws.</p> <p>Please note the following during installation:</p> <ul style="list-style-type: none"> ▪ The relevant regulations for potential-free installations must be observed. ▪ There must not be an electrically conductive connection between the piping and the device. ▪ The mounting material must be able to withstand the relevant torques. 	 <p style="text-align: right;">A0011896</p> <p>Fig. 48: Potential equalization and cathodic protection</p> <p>1 Isolation transformer power supply 2 Electrically isolated</p>

4.4 Degree of protection

The devices fulfill all the requirements for IP 67 (NEMA 4X).

Compliance with the following points is mandatory following installation in the field or servicing, in order to ensure that IP 67 protection (NEMA 4X) is maintained:

- The housing seals must be clean and undamaged when inserted into their grooves. The seals must be dried, cleaned or replaced if necessary.
- All threaded fasteners and screw covers must be firmly tightened.
- The cables used for connection must be of the specified external diameter → 102.
- Tighten cable glands to prevent leakages.
- The cables must loop down before they enter the cable entries ("water trap"). This arrangement prevents moisture penetrating the entry. Always install the measuring device in such a way that the cable entries do not point up.
- Close off unused cable entries using suitable insert plugs.
- Do not remove the grommet from the cable entry.

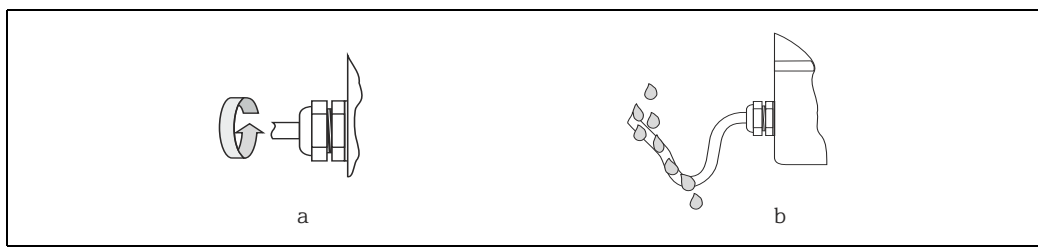

Fig. 49: Installation instructions, cable entries



Caution!

Do not loosen the threaded fasteners of the sensor housing, as otherwise the degree of protection guaranteed by Endress+Hauser no longer applies.



Note!

The Promag S sensor can be supplied with IP 68 rating (permanent immersion in water to a depth of 3 meters). In this case the transmitter must be installed remote from the sensor.

4.5 Post-connection check

Perform the following checks after completing electrical installation of the measuring device:

Device condition and specifications	Notes
Are cables or the device damaged (visual inspection)?	-
Electrical connection	Notes
Does the supply voltage match the specifications on the nameplate?	→ 102
Do the cables used comply with the necessary specifications?	→ 37
Do the cables have adequate strain relief?	-
Is the cable type route completely isolated? Without loops and crossovers?	-
Are the power-supply and electrode cables correctly connected?	See the wiring diagram inside the cover of the terminal compartment
Only remote version: Is the flow sensor connected to the matching transmitter electronics?	Check serial number on nameplates of sensor and connected transmitter
Only remote version: Is the connecting cable between sensor and transmitter connected correctly?	→ 33
Are all screw terminals firmly tightened?	-
Have the measures for grounding/potential equalization been correctly implemented?	→ 42ff
Are all cable entries installed, firmly tightened and correctly sealed? Cables looped as "water traps"?	→ 44
Are all housing covers installed and firmly tightened?	-

5 Operation

5.1 Display and operating elements

The local display enables you to read all important parameters directly at the measuring point and configure the device using the "Quick Setup" or the function matrix. The display area consists of two lines; this is where measured values are displayed, and/or status variables (direction of flow, partially filled pipe, bar graph, etc.). You can change the assignment of display lines to variables at will in order to customize the display to suit your needs and preferences (→ see the "Description of Device Functions" manual).

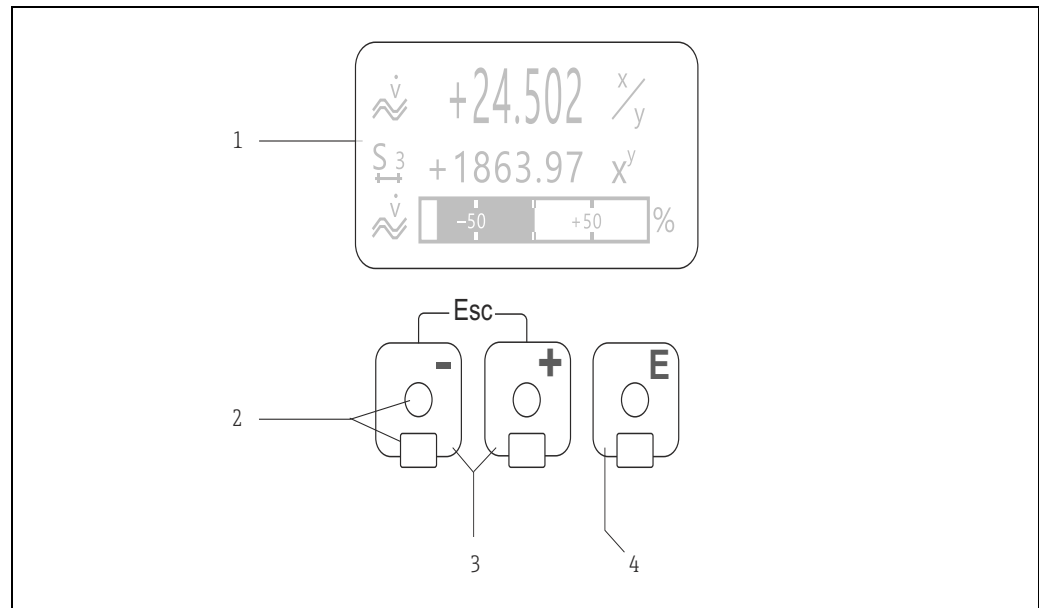

Fig. 50: Display and operating elements

- 1 LC-display
The backlit, four-line liquid-crystal display shows measured values, dialog texts and both system and process error messages. The display as it appears when normal measuring is in progress is known as the HOME position (operating mode).
- 2 Optical sensors for Touch Control
- 3 \square/\square keys
 - HOME position → Direct access to totalizer values and actual values of inputs/outputs
 - Enter numerical values, select parameters
 - Select different blocks, groups and function groups within the function matrix
 Press the \square/\square keys simultaneously to trigger the following functions:
 - Exit the function matrix step by step → HOME position
 - Press and hold down the \square/\square keys for longer than 3 seconds → Return directly to the HOME position
 - Cancel data entry
- 4 \square key (Enter key)
 - HOME position → Entry into the function matrix
 - Save the numerical values you input or settings you change

5.1.1 Display (operation mode)

The display area consists of three lines in total. This is where measured values and/or status variables (direction of flow, bar graph, etc.) are displayed. You can change the assignment of display lines to variables at will in order to customize the display to suit your needs and preferences (→ see the "Description of Device Functions" manual).

Multiplex mode:

A maximum of two different display variables can be assigned to each line. Variables multiplexed in this way alternate every 10 seconds on the display.

Error messages:

Display and presentation of system / process errors → 51.

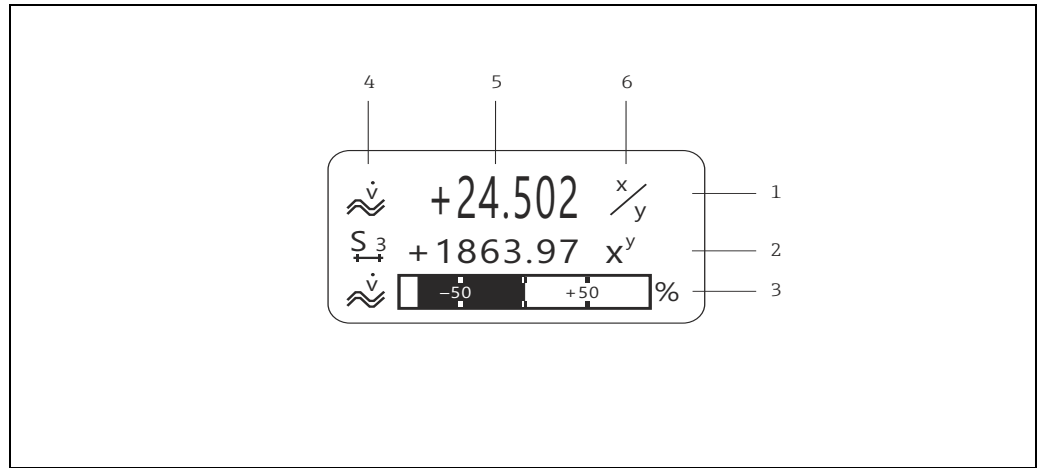































Fig. 51: Typical display for normal operating mode (HOME position)

- 1 Main line shows main measured values, e.g. flow
- 2 Supplementary line shows supplementary measured or status variables, e.g. totalizer reading.
- 3 Information line shows additional information on measured or status variables, e.g. bar graph representation of the full scale value attained by the flow rate
- 4 "Info icons" field shows additional information in the form of icons on the measured values displayed. See → 48 for a full list of the icons and their meanings.
- 5 "Measured values" field shows the current measured values.
- 6 "Unit of measure" field shows the units of measure and time defined for the current measured values.

5.1.2 Icons

The icons which appear in the field on the left make it easier to read and recognize measured variables, device status, and error messages.

Icon	Meaning	Icon	Meaning
	System error	P	Process error
	Fault message (with impact on outputs)	!	Notice message (without impact on outputs)
1 to n	Current output 1 to n	P 1 to n	Pulse output 1 to n
F 1 to n	Frequency output	S 1 to n	Status / relay output 1 to n (or status input)
Σ 1 to n	Totalizer 1 to n		
 a0001181	Measuring mode: PULSATING FLOW	 a0001182	Measuring mode: SYMMETRY (bidirectional)
 a0001183	Measuring mode: STANDARD	 a0001184	Counting mode totalizer: BALANCE (forward and reverse flow)
 a0001185	Counting mode totalizer: forward	 a0001186	Counting mode totalizer: reverse
 a0001187	Signal input (current or status input)	 a0001188	Volume flow
 a0001189	Target volume flow	 a0001191	Carrier volume flow
 a0001193	% Target volume flow	 a0001194	% Carrier volume flow
 a0001195	Mass flow	 a0001196	Target mass flow
 a0001198	Carrier mass flow	 a0001197	% Target mass flow
 a0001199	% Carrier mass flow	 a0001200	Fluid density
 a0006561	Deviation from reference value: Coating electrode 1	 a0006562	Deviation from reference value: Coating electrode 2
 a0006563	Deviation from reference value: Electrode potential 1	 a0006564	Deviation from reference value: Electrode potential 2
 a0006565	Deviation from reference value: Volume flow	 a0001207	Fluid temperature
 a0001209	Current input	 a0001206	Remote configuration Active device operation via: <ul style="list-style-type: none"> ■ HART, e.g. FieldCare, DXR375 ■ FOUNDATION Fieldbus ■ PROFIBUS
		 a0008380	Conductivity

5.2 Brief operating instruction to the function matrix



Note!

- See the general notes → 50
 - Function descriptions → see the "Description of Device Functions" manual
1. HOME position → → Enter the function matrix
 2. / → Select a block (e.g. OUTPUTS) → .
 3. / → Select a group (e.g. CURRENT OUTPUT 1) → .
 4. / → Select a function group (e.g. CONFIGURATION) → .
 5. Select a function (e.g. TIME CONSTANT) and change parameters / enter numerical values:
 - / → Select or enter release code, parameters, numerical values
 - Save entries
 6. Exit the function matrix:
 - Press and hold down Esc key () for longer than 3 seconds → HOME position
 - Repeatedly press Esc key () → return step by step to HOME position

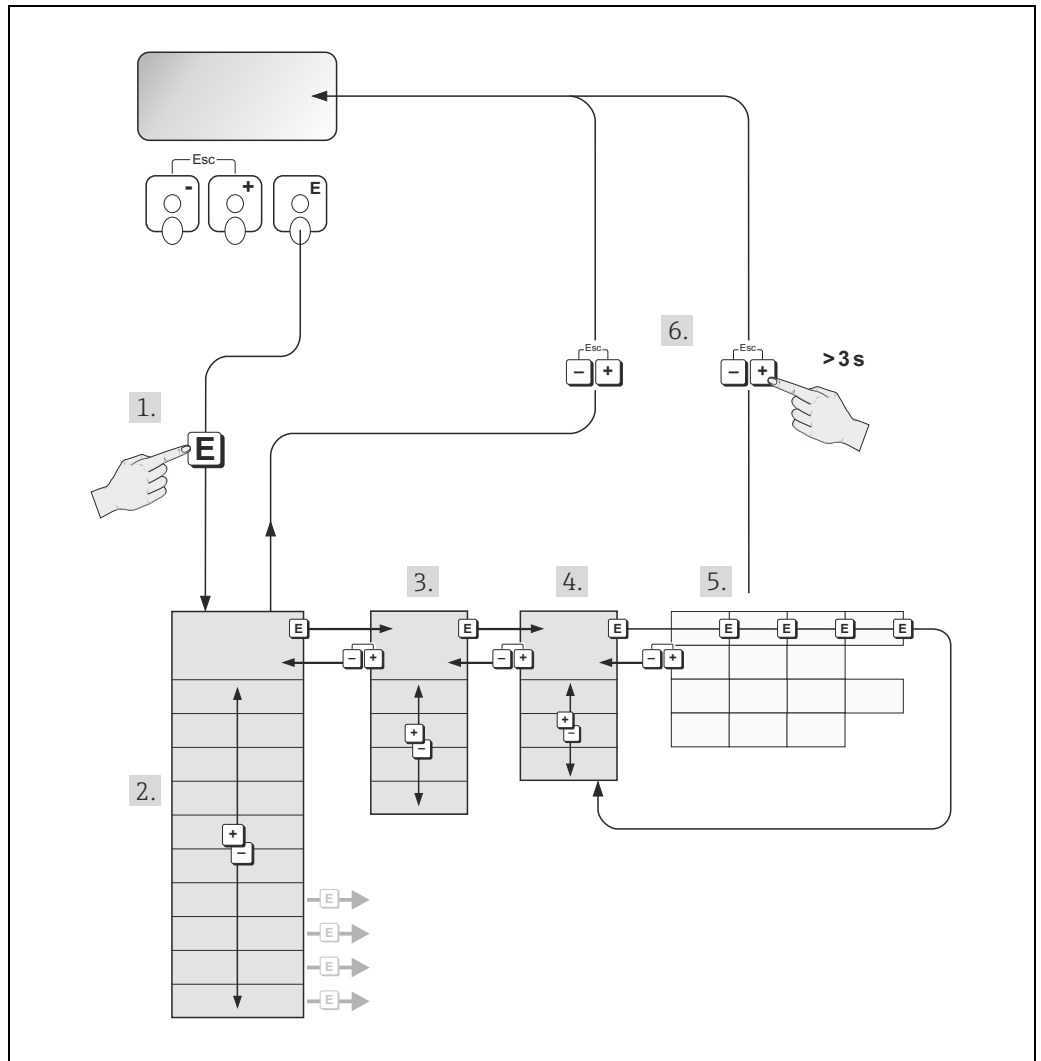



Fig. 52: Selecting functions and configuring parameters (function matrix)

a00012.10

5.2.1 General notes

The Quick Setup menu is adequate for commissioning with the necessary standard settings. Complex measuring operations on the other hand necessitate additional functions that you can configure as necessary and customize to suit your process parameters. The function matrix, therefore, comprises a multiplicity of additional functions which, for the sake of clarity, are arranged on a number of menu levels (blocks, groups, and function groups).

Comply with the following instructions when configuring functions:

- You select functions as described →  49.
 - Each cell in the function matrix is identified by a numerical or letter code on the display.
- You can switch off certain functions (OFF). If you do so, related functions in other function groups will no longer be displayed.
- Certain functions prompt you to confirm your data entries. Press O/S to select "SURE | YES |" and press F again to confirm. This saves your setting or starts a function, as applicable.
- Return to the HOME position is automatic if no key is pressed for 5 minutes.
- Programming mode is automatically disabled if you do not press a key within 60 seconds following automatic return to the HOME position.



Caution!

All functions are described in detail, including the function matrix itself, in the "Description of Device Functions" manual, which is a separate part of these Operating Instructions.



Note!



- The transmitter continues to measure while data entry is in progress, i.e. the current measured values are output via the signal outputs in the normal way.
- If the power supply fails, all preset and parameterized values remain safely stored in the EEPROM.

5.2.2 Enabling the programming mode

The function matrix can be disabled. Disabling the function matrix rules out the possibility of inadvertent changes to device functions, numerical values or factory settings. A numerical code (factory setting = 55) has to be entered before settings can be changed.

If you use a code number of your choice, you exclude the possibility of unauthorized persons accessing data (→ "Description of Device Functions" manual).

Comply with the following instructions when entering codes:

- If programming is disabled and the  /  keys are pressed in any function, a prompt for the code automatically appears on the display.
- If "0" is entered as the customer's code, programming is always enabled.
- The Endress+Hauser service organization can be of assistance if you mislay your personal code.



Caution!

Changing certain parameters such as all sensor characteristics, for example, influences numerous functions of the entire measuring system, particularly measuring accuracy. There is no need to change these parameters under normal circumstances and consequently, they are protected by a special code known only to the Endress+Hauser service organization. Please contact Endress+Hauser if you have any questions.

5.2.3 Disabling the programming mode

Programming mode is disabled if you do not press a key within 60 seconds following automatic return to the HOME position.

You can also disable programming in the ACCESS CODE function by entering any number (other than the customer's code).

5.3 Error messages

5.3.1 Type of error

Errors which occur during commissioning or measuring operation are displayed immediately. If two or more system or process errors occur, the error with the highest priority is the one shown on the display.

The measuring system distinguishes between two types of error:

- **System errors:** This group comprises all device errors, e.g. communication errors, hardware errors, etc. → 86
- **Process errors:** This group comprises all application errors, e.g. inhomogeneous fluid, etc. → 90

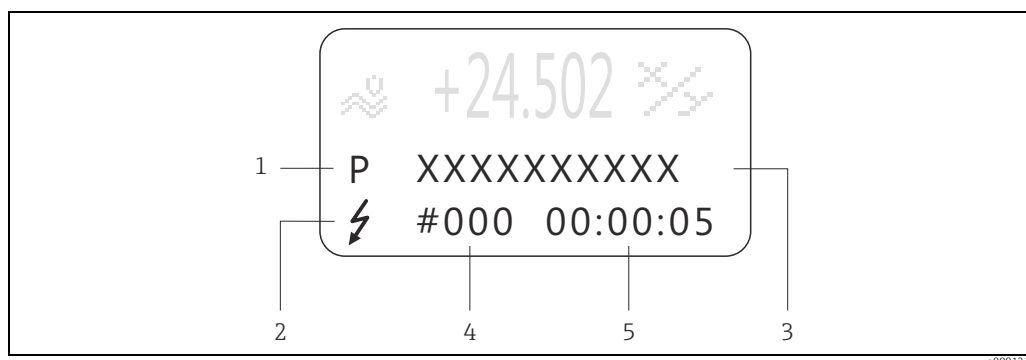

Fig. 53: Error messages on the display (example)

- 1 Error type: P = process error, S = system error
- 2 Error message type: ⚡ = fault message, ! = notice message
- 3 Error designation
- 4 Error number
- 5 Duration of most recent error occurrence (hours : minutes : seconds)

5.3.2 Error message type

Users have the option of weighting certain errors differently, in other words having them classed as **Fault messages** or **Notice messages**. You can define messages in this way with the aid of the function matrix (see the "Description of Device Functions" manual).

Serious system errors, e.g. module defects, are always identified and classed as "fault messages" by the measuring device.

Notice message (!)

- Displayed as → exclamation mark (!), error type (S: system error, P: process error)
- The error in question has no effect on the outputs of the measuring device.

Fault message (⚡)

- Displayed as → lightning flash (⚡), error type (S: system error, P: process error)
- The error in question has a direct effect on the outputs.

The response of the outputs (failsafe mode) can be defined by means of functions in the function matrix → 90



Note!

- Fault conditions can be output via the relay outputs.
- If an error message appears, an upper or lower signal on alarm level according to NAMUR NE 43 can be output via the current output.

5.3.3 Confirming error messages

For the sake of plant and process safety, the measuring device can be configured in such a way that fault messages (⚡) always have to be rectified and acknowledged locally by pressing . Only then do the error messages disappear from the display.

This option can be switched on or off by means of the ACKNOWLEDGE FAULT MESSAGES function (see the "Description of Device Functions" manual).



Note!

- Fault messages (⚡) can also be reset and confirmed via the status input.
- Notice messages (!) do not require acknowledgment. Note, however, that they remain visible until the cause of the error has been rectified.

5.4 Communication

In addition to local operation, the measuring device can be configured and measured values can be obtained by means of the HART protocol. Digital communication takes place using the 4–20 mA current output HART →  41.

The HART protocol allows the transfer of measuring and device data between the HART master and the field devices for configuration and diagnostics purposes. The HART master, e.g. a handheld terminal or PC-based operating programs (such as FieldCare), require device description (DD) files which are used to access all the information in a HART device.

Information is exclusively transferred using so-called "commands". There are three different command groups:

There are three different command groups:

- *Universal commands*

All HART device support and use universal commands. The following functionalities, for example, are linked to them:

- Identify HART devices
- Reading digital measured values (volume flow, totalizer, etc.)

- *Common practice commands:*

Common practice commands offer functions which are supported and can be executed by most but not all field devices.

- *Device-specific commands:*

These commands allow access to device-specific functions which are not HART standard. Amongst other things, such commands access individual field device information, such as empty-pipe/full-pipe calibration values, low flow cutoff settings, etc.



Note!

The device has access to all three command classes.

List of all "universal commands" and "common practice commands" →  55

5.4.1 Operating options

For the complete operation of the measuring device, including device-specific commands, there are DD files available to the user to provide the following operating aids and programs:



Note!

- In the CURRENT SPAN function (current output 1), the HART protocol demands the setting "4-20 mA HART" or "4-20 mA (25 mA) HART".
- HART write protection can be enabled or disabled by means of a jumper on the I/O board → 63.

Field Xpert HART Communicator

Selecting device functions with a HART Communicator is a process involving a number of menu levels and a special HART function matrix.

The HART manual in the carrying case of the HART Communicator contains more detailed information on the device.

Operating program "FieldCare"

Fieldcare is Endress+Hauser's FDT-based plant Asset Management Tool and allows the configuration and diagnosis of intelligent field devices. By using status information, you also have a simple but effective tool for monitoring devices. The Proline flow measuring devices are accessed via a service interface or via the service interface FXA193.

Operating program "SIMATIC PDM" (Siemens)

SIMATIC PDM is a standardized, manufacturer-independent tool for the operation, configuration, maintenance and diagnosis of intelligent field devices.

Operating program "AMS" (Emerson Process Management)

AMS (Asset Management Solutions): program for operating and configuring devices

5.4.2 Current device description files

The following table illustrates the suitable device description file for the operating tool in question and then indicates where these can be obtained.

HART protocol:

Valid for software	1.02.XX	→ "Device software" function (8100)
Device data HART		
Manufacturer ID:	11 _{hex} (ENDRESS+HAUSER)	→ "Manufact ID" function (6040)
Device ID:	44 _{hex}	→ "Device ID" function (6041)
HART version data	Device Revision 3/ DD Revision 1	
Software release	06.2009	
Operating	Sources for obtaining device descriptions	
Handheld terminal DXR375	■ Use update function of handheld terminal	
FieldCare / DTM	<ul style="list-style-type: none"> ■ www.endress.com → Download ■ CD-ROM (Endress+Hauser order number 56004088) ■ DVD (Endress+Hauser order number 70100690) 	
AMS	www.endress.com → Download	
SIMATIC PDM	www.endress.com → Download	

Tester/simulator	Sources for obtaining device descriptions
Fieldcheck	Update via FieldCare using the Flow Device FXA193/291 DTM in the Fieldflash module

5.4.3 Device and process variables

Device variables:

The following device variables are available using the HART protocol:

Device and process variables	Device variable
0	OFF (not assigned)
1	Volume flow
2	Mass flow
3	Conductivity
12	Target mass flow
13	% Target mass flow
14	Target volume flow
15	% Target volume flow
17	Carrier mass flow
18	% Carrier mass flow
19	Carrier volume flow
20	% Carrier volume flow
88	Deviation Coating 1
89	Deviation Coating 2
90	Deviation electrode potential 1
91	Deviation electrode potential 2
92	Deviation volume flow
250	Totalizer 1
251	Totalizer 2
252	Totalizer 3

Process variables:

At the factory, the process variables are assigned to the following device variables:



- Primary process variable (PV) → Volume flow
- Second process variable (SV) → Totalizer 1
- Third process variable (TV) → Mass flow
- Fourth process variable (FV) → not assigned













Note!



You can set or change the assignment of device variables to process variables using Command 51 → 58.

5.4.4 Universal/Common practice HART commands

Command No. HART command / Access type		Command data (numeric data in decimal form)	Response data (numeric data in decimal form)
Universal Commands			
0	Read unique device identifier Access type = read	None	<p>Device identification delivers information on the device and the manufacturer. It cannot be changed.</p> <p>The response consists of a 12 byte device ID:</p> <ul style="list-style-type: none"> ▪ Byte 0: fixed value 254 ▪ Byte 1: Manufacturer ID, 17 = E+H ▪ Byte 2: Device type ID, e.g. 44 = Promag 55 ▪ Byte 3: Number of preambles ▪ Byte 4: Universal commands rev. no. ▪ Byte 5: Device-specific rev. no. Commands ▪ Byte 6: Software revision ▪ Byte 7: Hardware revision ▪ Byte 8: Additional device information ▪ Bytes 9-11: Device identification
1	Read primary process variable Access type = read	None	<ul style="list-style-type: none"> ▪ Byte 0: HART unit code of the primary process variable ▪ Bytes 1-4: Primary process variable <p><i>Factory setting:</i> Primary process variable = Volume flow</p> <p> Note!</p> <ul style="list-style-type: none"> ▪ You can set or change the assignment of device variables to process variables using Command 51. ▪ Manufacturer-specific units are represented using the HART unit code "240".
2	Read the primary process variable as current in mA and percentage of the set measuring range Access type = read	None	<ul style="list-style-type: none"> ▪ Bytes 0-3: actual current of the primary process variable in mA ▪ Bytes 4-7: Percentage of the set measuring range <p><i>Factory setting:</i> Primary process variable = Volume flow</p> <p> Note!</p> <p>You can set the assignment of device variables to process variables using Command 51.</p>
3	Read the primary process variable as current in mA and four (preset using Command 51) dynamic process variables Access type = read	None	<p>24 bytes are sent as a response:</p> <ul style="list-style-type: none"> ▪ Bytes 0-3: primary process variable current in mA ▪ Byte 4: HART unit code of the primary process variable ▪ Bytes 5-8: Primary process variable ▪ Byte 9: HART unit code of the second process variable ▪ Bytes 10-13: Second process variable ▪ Byte 14: HART unit code of the third process variable ▪ Bytes 15-18: Third process variable ▪ Byte 19: HART unit code of the fourth process variable ▪ Bytes 20-23: Fourth process variable <p><i>Factory setting:</i></p> <ul style="list-style-type: none"> ▪ Primary process variable = Volume flow ▪ Second process variable = Totalizer 1 ▪ Third process variable = Mass flow ▪ Fourth process variable = OFF (not assigned) <p> Note!</p> <ul style="list-style-type: none"> ▪ You can set the assignment of device variables to process variables using Command 51. ▪ Manufacturer-specific units are represented using the HART unit code "240".

Command No. HART command / Access type		Command data (numeric data in decimal form)	Response data (numeric data in decimal form)
6	Set HART shortform address Access type = write	Byte 0: desired address (0 to 15) <i>Factory setting:</i> 0  Note! With an address >0 (multidrop mode), the current output of the primary process variable is set to 4 mA.	Byte 0: active address
11	Read unique device identification using the TAG (measuring point designation) Access type = read	Bytes 0-5: TAG	Device identification delivers information on the device and the manufacturer. It cannot be changed. The response consists of a 12 byte device ID if the given TAG agrees with the one saved in the device: <ul style="list-style-type: none"> ▪ Byte 0: fixed value 254 ▪ Byte 1: Manufacturer ID, 17 = E+H ▪ Byte 2: Device type ID, 44 = Promag 55 ▪ Byte 3: Number of preambles ▪ Byte 4: Universal commands rev. no. ▪ Byte 5: Device-specific rev. no. Commands ▪ Byte 6: Software revision ▪ Byte 7: Hardware revision ▪ Byte 8: Additional device information ▪ Bytes 9-11: Device identification
12	Read user message Access type = read	None	Bytes 0-24: User message  Note! You can write the user message using Command 17.
13	Read TAG, descriptor and date Access type = read	None	<ul style="list-style-type: none"> ▪ Bytes 0-5: TAG ▪ Bytes 6-17: descriptor ▪ Bytes 18-20: Date  Note! You can write the TAG, descriptor and date using Command 18.
14	Read sensor information on primary process variable	None	<ul style="list-style-type: none"> ▪ Bytes 0-2: Sensor serial number ▪ Byte 3: HART unit code of sensor limits and measuring range of the primary process variable ▪ Bytes 4-7: Upper sensor limit ▪ Bytes 8-11: Lower sensor limit ▪ Bytes 12-15: Minimum span  Note! <ul style="list-style-type: none"> ▪ The data relate to the primary process variable (= volume flow). ▪ Manufacturer-specific units are represented using the HART unit code "240".
15	Read output information of primary process variable Access type = read	None	<ul style="list-style-type: none"> ▪ Byte 0: Alarm selection ID ▪ Byte 1: Transfer function ID ▪ Byte 2: HART unit code for the set measuring range of the primary process variable ▪ Bytes 3-6: End of measuring range, value for 20 mA ▪ Bytes 7-10: Start of measuring range, value for 4 mA ▪ Bytes 11-14: Attenuation constant in [s] ▪ Byte 15: Write protection ID ▪ Byte 16: OEM dealer ID, 17 = E+H <i>Factory setting:</i> Primary process variable = Volume flow  Note! <ul style="list-style-type: none"> ▪ You can set the assignment of device variables to process variables using Command 51. ▪ Manufacturer-specific units are represented using the HART unit code "240".

Command No. HART command / Access type		Command data (numeric data in decimal form)	Response data (numeric data in decimal form)
16	Read the device production number Access type = read	None	Bytes 0-2: Production number
17	Write user message Access = write	You can save any 32-character long text in the device under this parameter: Bytes 0-23: Desired user message	Displays the current user message in the device: Bytes 0-23: Current user message in the device
18	Write TAG, descriptor and date Access = write	With this parameter, you can store an 8 character TAG, a 16 character descriptor and a date: <ul style="list-style-type: none"> Bytes 0-5: TAG Bytes 6-17: descriptor Bytes 18-20: Date 	Displays the current information in the device: <ul style="list-style-type: none"> Bytes 0-5: TAG Bytes 6-17: descriptor Bytes 18-20: Date
Common Practice Commands			
34	Write attenuation constant for primary process variable Access = write	Bytes 0-3: Attenuation constant of the primary process variable in seconds <i>Factory setting:</i> Primary process variable = Volume flow	Displays the current attenuation constant in the device: Bytes 0-3: Attenuation constant in seconds
35	Write measuring range of primary process variable Access = write	Write the desired measuring range: <ul style="list-style-type: none"> Byte 0: HART unit code of the primary process variable Bytes 1-4: upper range, value for 20 mA Bytes 5-8: lower range, value for 4 mA <i>Factory setting:</i> Primary process variable = Volume flow  Note! <ul style="list-style-type: none"> You can set the assignment of device variables to process variables using Command 51. If the HART unit code is not the correct one for the process variable, the device will continue with the last valid unit. 	The currently set measuring range is displayed as a response: <ul style="list-style-type: none"> Byte 0: HART unit code for the set measuring range of the primary process variable Bytes 1-4: upper range, value for 20 mA Bytes 5-8: lower range, value for 4 mA  Note! Manufacturer-specific units are represented using the HART unit code "240".
38	Device status reset (Configuration changed) Access = write	None	None
40	Simulate output current of primary process variable Access = write	Simulation of the desired output current of the primary process variable. An entry value of 0 exits the simulation mode: Bytes 0-3: Output current in mA <i>Factory setting:</i> Primary process variable = Volume flow  Note! You can set the assignment of device variables to process variables using Command 51.	The momentary output current of the primary process variable is displayed as a response: Bytes 0-3: Output current in mA
42	Perform master reset Access = write	None	None
44	Write unit of primary process variable Access = write	Set unit of primary process variable. Only unit which are suitable for the process variable are transferred to the device: Byte 0: HART unit code <i>Factory setting:</i> Primary process variable = Volume flow  Note! <ul style="list-style-type: none"> If the written HART unit code is not the correct one for the process variable, the device will continue with the last valid unit. If you change the unit of the primary process variable, this has no impact on the system units. 	The current unit code of the primary process variable is displayed as a response: Byte 0: HART unit code  Note! Manufacturer-specific units are represented using the HART unit code "240".

Command No. HART command / Access type		Command data (numeric data in decimal form)	Response data (numeric data in decimal form)
48	Read additional device status Access = read	None	The device status is displayed in extended form as the response: Coding: see table → 59
50	Read assignment of the device variables to the four process variables Access = read	None	Display of the current variable assignment of the process variables: <ul style="list-style-type: none"> Byte 0: Device variable code to the primary process variable Byte 1: Device variable code to the second process variable Byte 2: Device variable code to the third process variable Byte 3: Device variable code to the fourth process variable <i>Factory setting:</i> <ul style="list-style-type: none"> Primary process variable: Code 1 for volume flow Second process variable: Code 250 for totalizer 1 Third process variable: Code 2 for mass flow Fourth process variable: Code 0 for OFF (not assigned)  Note! You can set the assignment of device variables to process variables using Command 51.
51	Write assignments of the device variables to the four process variables Access = write	Setting of the device variables to the four process variables: <ul style="list-style-type: none"> Byte 0: Device variable code to the primary process variable Byte 1: Device variable code to the second process variable Byte 2: Device variable code to the third process variable Byte 3: Device variable code to the fourth process variable <i>Code of the supported device variables:</i> See information → 54 <i>Factory setting:</i> <ul style="list-style-type: none"> Primary process variable = Volume flow Second process variable = Totalizer 1 Third process variable = Mass flow Fourth process variable = OFF (not assigned) 	The variable assignment of the process variables is displayed as a response: <ul style="list-style-type: none"> Byte 0: Device variable code to the primary process variable Byte 1: Device variable code to the second process variable Byte 2: Device variable code to the third process variable Byte 3: Device variable code to the fourth process variable
53	Write device variable unit Access = write	This command set the unit of the given device variables. Only those units which suit the device variable are transferred: <ul style="list-style-type: none"> Byte 0: Device variable code Byte 1: HART unit code <i>Code of the supported device variables:</i> See information → 54  Note! <ul style="list-style-type: none"> If the written unit is not the correct one for the device variable, the device will continue with the last valid unit. If you change the unit of the device variable, this has no impact on the system units. 	The current unit of the device variables is displayed in the device as a response: <ul style="list-style-type: none"> Byte 0: Device variable code Byte 1: HART unit code  Note! Manufacturer-specific units are represented using the HART unit code "240".
59	Write number of preambles in response message Access = write	This parameter sets the number of preambles which are inserted in the response messages: Byte 0: Number of preambles (2 to 20)	As a response, the current number of the preambles is displayed in the response message: Byte 0: Number of preambles

5.4.5 Device status/Error messages

You can read the extended device status, in this case, current error messages, via Command "48". The command delivers information which are partly coded in bits (see table below).



Note!

For a detailed explanation of the device status and error messages and their elimination, see → 85.

Byte-Bit	Error No.	Short description of error → 85
0-0	001	Serious device error
0-1	011	Measuring amplifier has faulty EEPROM
0-2	012	Error when accessing data of the measuring amplifier EEPROM
0-3	Not assigned	–
0-4	Not assigned	–
0-5	Not assigned	–
0-6	Not assigned	–
0-7	Not assigned	–
1-0	Not assigned	–
1-1	031	S-DAT: defective or missing
1-2	032	S-DAT: Error accessing saved values
1-3	041	T-DAT: defective or missing
1-4	042	T-DAT: Error accessing saved values
1-5	Not assigned	–
1-6	Not assigned	–
1-7	Not assigned	–
2-0	Not assigned	–
2-1	Not assigned	–
2-2	Not assigned	–
2-3	Not assigned	–
2-4	Not assigned	–
2-5	Not assigned	–
2-6	Not assigned	–
2-7	Not assigned	–
3-0	Not assigned	–
3-1	Not assigned	–
3-2	Not assigned	–
3-3	111	Totalizer checksum error
3-4	121	I/O board and the amplifier board are not compatible.
3-5	Not assigned	–
3-6	205	T-DAT: Data download unsuccessful
3-7	206	T-DAT: Data upload unsuccessful
4-0	Not assigned	–
4-1	Not assigned	–
4-2	Not assigned	–
4-3	251	Internal communication error on amplifier board
4-4	261	No data reception between amplifier and I/O board

Byte-Bit	Error No.	Short description of error →  85
4-5	Not assigned	-
4-6	Not assigned	-
4-7	Not assigned	-
5-0	321	Coil current of the sensor is outside the tolerance.
5-1	840	The deviation of the decay time on measuring electrode 1 has exceeded the warning level.
5-2	841	The deviation of the decay time on measuring electrode 2 has exceeded the warning level.
5-3	Not assigned	-
5-4	Not assigned	-
5-5	Not assigned	-
5-6	845	Coating detection could not be performed successfully.
5-7	339	Flow buffer: The temporarily buffered flow portions (measuring mode for pulsating flow) could not be cleared or output within 60 seconds.
6-0	340	
6-1	341	
6-2	342	
6-3	343	Frequency buffer: The temporarily buffered flow portions (measuring mode for pulsating flow) could not be cleared or output within 60 seconds.
6-4	344	
6-5	345	
6-6	346	
6-7	347	Pulse buffer: The temporarily buffered flow portions (measuring mode for pulsating flow) could not be cleared or output within 60 seconds.
7-0	348	
7-1	349	
7-2	350	Current output: Actual flow value is out of range.
7-3	351	
7-4	352	
7-5	353	
7-6	354	Frequency output: Actual flow value is out of range.
7-7	355	
8-0	356	
8-1	357	
8-2	358	Pulse output: The pulse output frequency is outside the permitted range.
8-3	359	
8-4	360	
8-5	361	
8-6	362	
8-7	Not assigned	-
9-0	Not assigned	-
9-1	Not assigned	-
9-2	Not assigned	-
9-3	Not assigned	-
9-4	Not assigned	-
9-5	Not assigned	-
9-6	Not assigned	

Byte-Bit	Error No.	Short description of error → ⓘ 85
9-7	Not assigned	
10-0	Not assigned	–
10-1	Not assigned	–
10-2	Not assigned	–
10-3	Not assigned	–
10-4	Not assigned	–
10-5	Not assigned	–
10-6	Not assigned	–
10-7	401	Measuring tube partially filled or empty
11-0	846	The deviation of the noise value has exceeded the warning level.
11-1	Not assigned	–
11-2	461	EPD adjustment not possible because the fluid's conductivity is either too low or too high.
11-3	Not assigned	–
11-4	463	The EPD adjustment values for empty pipe and full pipe are identical and therefore incorrect.
11-5	Not assigned	–
11-6	Not assigned	–
11-7	Not assigned	–
12-0	Not assigned	–
12-1	Not assigned	–
12-2	Not assigned	–
12-3	Not assigned	–
12-4	Not assigned	–
12-5	Not assigned	–
12-6	Not assigned	–
12-7	501	New amplifier software version is loaded. Currently no other commands are possible.
13-0	502	Up-/downloading device data is active. Currently no other commands are possible.
13-1	Not assigned	–
13-2	Not assigned	–
13-3	Not assigned	–
13-4	Not assigned	–
13-5	Not assigned	–
13-6	Not assigned	–
13-7	Not assigned	–
14-0	Not assigned	–
14-1	Not assigned	–
14-2	Not assigned	–
14-3	601	Positive zero return active
14-4	Not assigned	–
14-5	Not assigned	–
14-6	Not assigned	–

Byte-Bit	Error No.	Short description of error →  85
14-7	611	Simulation current output active
15-0	612	
15-1	613	
15-2	614	
15-3	621	Simulation frequency output active
15-4	622	
15-5	623	
15-6	624	
15-7	631	Simulation pulse output active
16-0	632	
16-1	633	
16-2	634	
16-3	641	Simulation status output active
16-4	642	
16-5	643	
16-6	644	
16-7	651	Simulation relay output active
17-0	652	
17-1	653	
17-2	654	
17-3	661	Simulation current input active
17-4	662	-
17-5	663	-
17-6	664	-
17-7	671	Simulation status input active
18-0	672	
18-1	673	
18-2	674	
18-3	691	Simulation of response to error (outputs) active
18-4	692	Simulation of volume flow is active
18-5	Not assigned	-
18-6	Not assigned	-
18-7	Not assigned	-
19-0	Not assigned	-
19-1	Not assigned	-
19-2	Not assigned	-
19-3	Not assigned	-
19-4	Not assigned	-
19-5	Not assigned	-
19-6	Not assigned	-
19-7	Not assigned	-
20-0	Not assigned	-
20-1	Not assigned	-

Byte-Bit	Error No.	Short description of error → 85
20-2	Not assigned	–
20-3	Not assigned	–
20-4	Not assigned	–
20-5	Not assigned	–
20-6	Not assigned	–
20-7	Not assigned	–
22-4	61	F-CHIP is defective or not on I/O board
24-5	363	Current input: Actual current value is out of range.

5.4.6 Switching HART write protection on and off

A jumper on the I/O board provides the means of activating or deactivating HART write protection.



Warning!

Risk of electric shock. Exposed components carry dangerous voltages. Make sure that the power supply is switched off before you remove the cover of the electronics compartment.

1. Switch off power supply.
2. Remove the I/O board → 95.
3. Switch HART write protection on or off, as applicable, by means of the jumper (Fig. 47).
4. Installation of the I/O board is the reverse of the removal procedure.

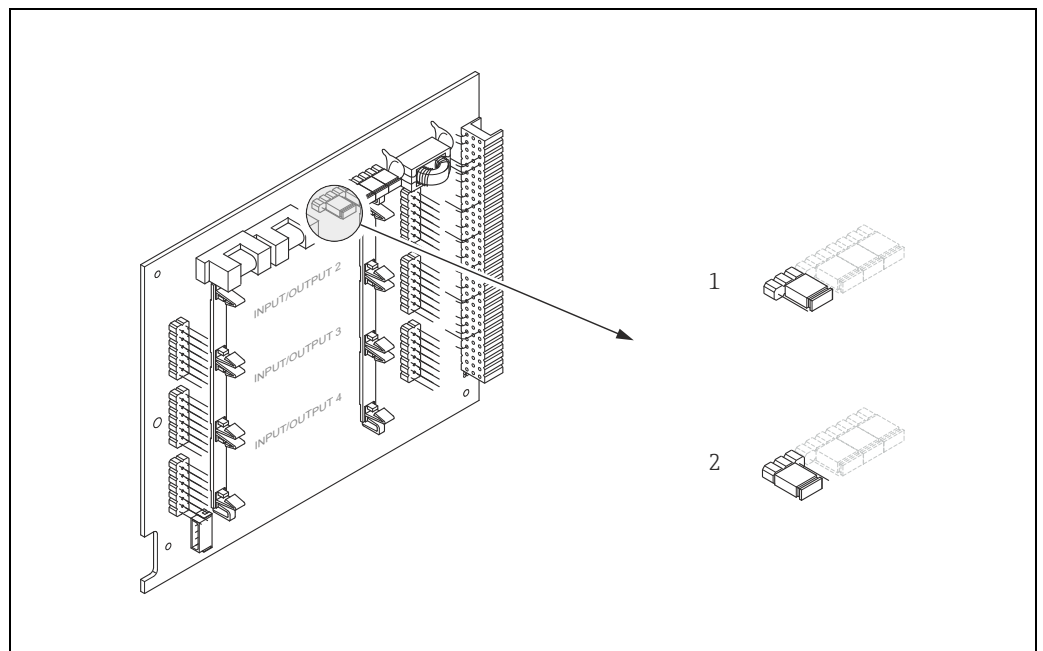

Fig. 54: Switching HART write protection on and off

- 1 Write protection OFF (default), i.e. HART protocol unlocked
- 2 Write protection ON, i.e. HART protocol locked

6 Commissioning

6.1 Function check

Make sure that all final checks have been completed before you start up your measuring point:

- Checklist for "Post-installation check" →  32
- Checklist for "Post-connection check" →  45

6.2 Switching on the measuring device

Once the connection checks have been successfully completed, it is time to switch on the power supply. The device is now operational.

The measuring device performs a number of post switch-on self-tests. As this procedure progresses the following sequence of messages appears on the local display:

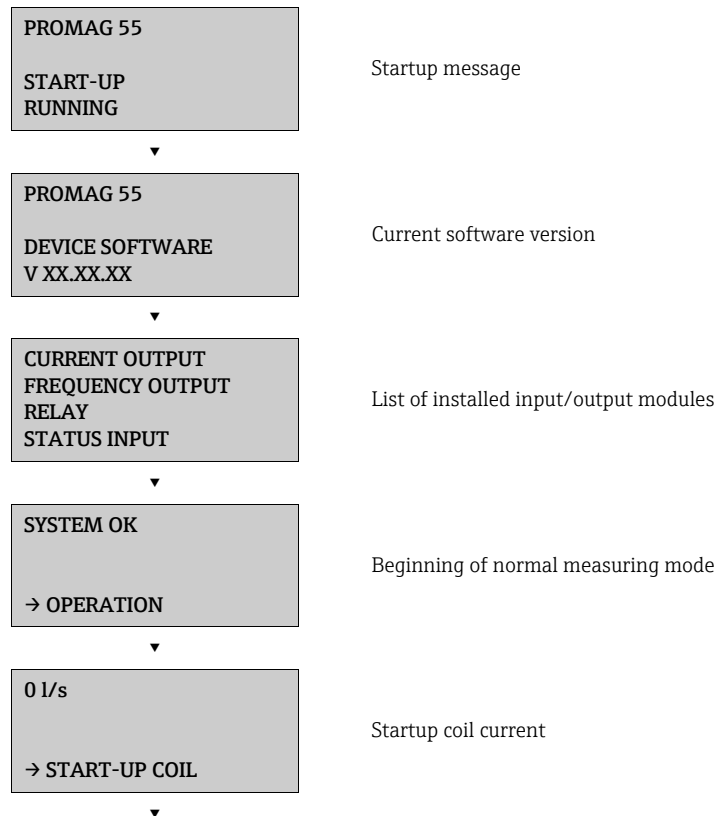

Normal measuring mode commences as soon as startup completes.

Various measured-value and/or status variables (HOME position) appear on the display.



Note!

If startup fails, an error message indicating the cause is displayed.

6.3 Quick Setup

In the case of measuring devices without a local display, the individual parameters and functions must be configured by means of a configuration program, such as FieldCare from Endress+Hauser.

If the measuring device is equipped with a local display, all the important device parameters for standard operation can be configured quickly and easily by means of the following Quick Setup menus. Additional functions can be configured too.

6.3.1 "Commissioning" Quick Setup menu

This Quick Setup menu guides you systematically through the setup procedure for all the major device functions that have to be configured for standard measuring operation.



Note!

- The display returns to the cell SETUP COMMISSIONING (1002) if you press the ESC key combination during parameter interrogation. The stored parameters remain valid.
 - The "Commissioning" Quick Setup must be carried out before any of the other Quick Setups described in this Operating Instructions are run.
- ① The DELIVERY SETTINGS option sets each selected unit to the factory setting. The ACT.SETTING option accepts the units previously set by you.
 - ② Only units not yet configured in the current setup are offered for selection in each cycle. The unit for mass and volume is derived from the corresponding flow unit.
 - ③ The "YES" option remains visible until all the units have been configured. "NO" is the only option displayed when no further units are available.
 - ④ The prompt appears only if a current output and/or a pulse/frequency output is available. Only the outputs not yet configured in the current setup are offered for selection in each cycle.
 - ⑤ The "YES" option remains visible until all the outputs have been parameterized. "NO" is the only option displayed when no further outputs are available.
 - ⑥ The "automatic parameterization of the display" option contains the following basic settings/factory settings

YES	Main line = volume flow
	Additional line = totalizer 1
	Information line = operating/system conditions
NO	The existing (selected) settings remain.

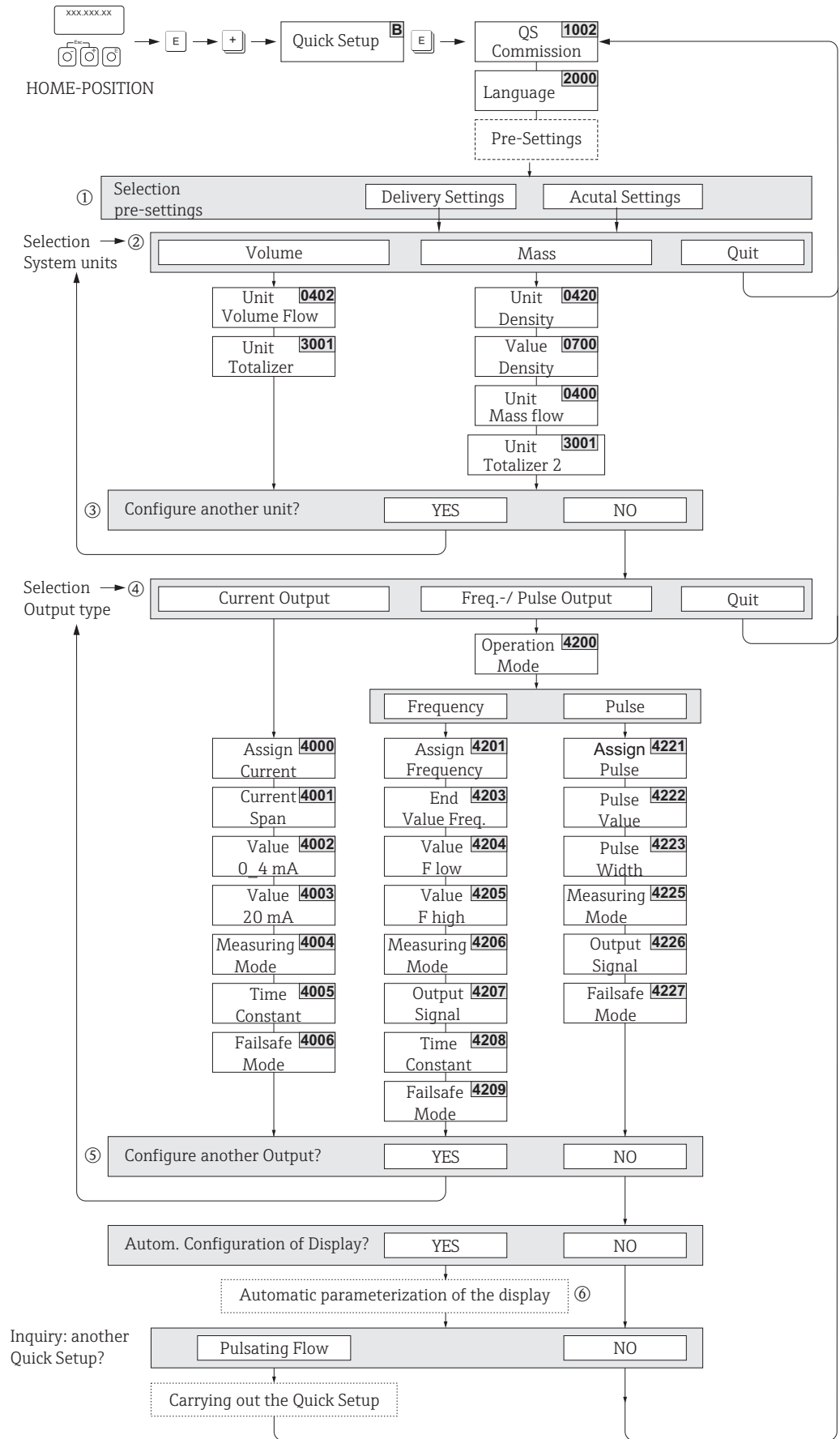

a0005872-en

Fig. 55: Quick Setup for straightforward commissioning

6.3.2 "Pulsating flow" Quick Setup menu

Certain pumps of a construction which necessitates a pulsating pumping action, such as reciprocating, peristaltic and cam-type pumps, create a flow characterized by severe periodic fluctuations. Negative flows can occur with pumps of these types on account of the closing volume of the valves or valve leaks.



Note!

Before carrying out the "Pulsating Flow" Quick Setup, the "Commissioning" Quick Setup must be executed → 65.

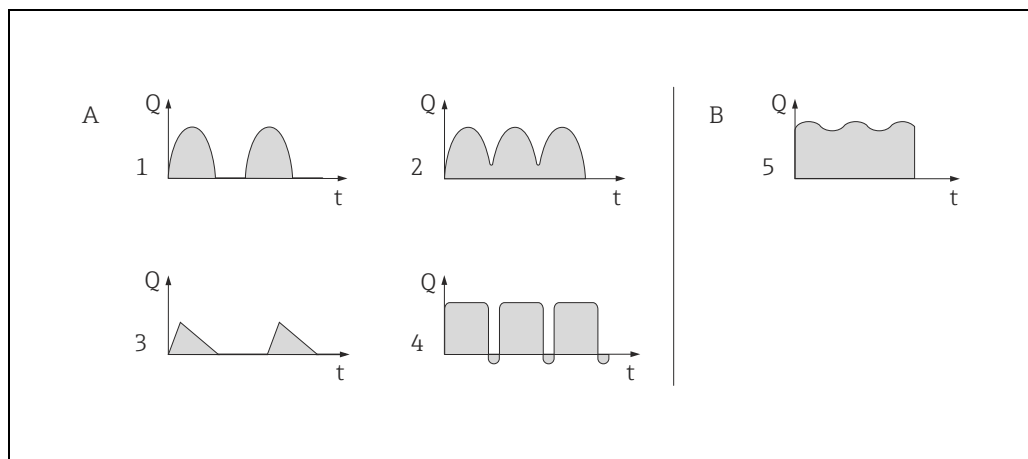

Fig. 56: Flow characteristics of various types of pump

A with severely pulsating flow
B with slightly pulsating flow

- 1 1-cylinder cam pump
- 2 2-cylinder cam pump
- 3 Magnetic pump
- 4 Peristaltic pump, flexible connecting hose
- 5 Multi-cylinder reciprocating pump

Severely pulsating flow

Once several device functions have been configured in the "Pulsating Flow" Quick Setup menu, flow fluctuations can be compensated over the entire flow range and pulsating liquid flows measured correctly. The following describes in detail how to use this Quick Setup menu.



Note!

It is always advisable to work run the "Pulsating Flow" Quick Setup if there is any uncertainty about the exact flow characteristic.

Slightly pulsating flow

If flow fluctuations are no more than minor, as is the case, for example with gear-type, three-cylinder or multi-cylinder pumps, it is **not** absolutely necessary to work through the "Pulsating Flow" menu.

In cases of this nature, however, it is advisable to adapt the functions listed below (see "Description of Device Functions" manual) to suit local process conditions in order to ensure a stable, unvarying output signal. This applies particularly to the current output:

- Measuring system damping: SYSTEM DAMPING function → increase the value
- Current output damping: TIME CONSTANT function → increase the value

Using the "Pulsating Flow" Quick Setup menu

This Quick Setup menu guides you systematically through the setup procedure for all the device functions that have to be configured for measuring pulsating flows. Note that this has no effect on values already configured, such as measuring range, current range or full scale value.

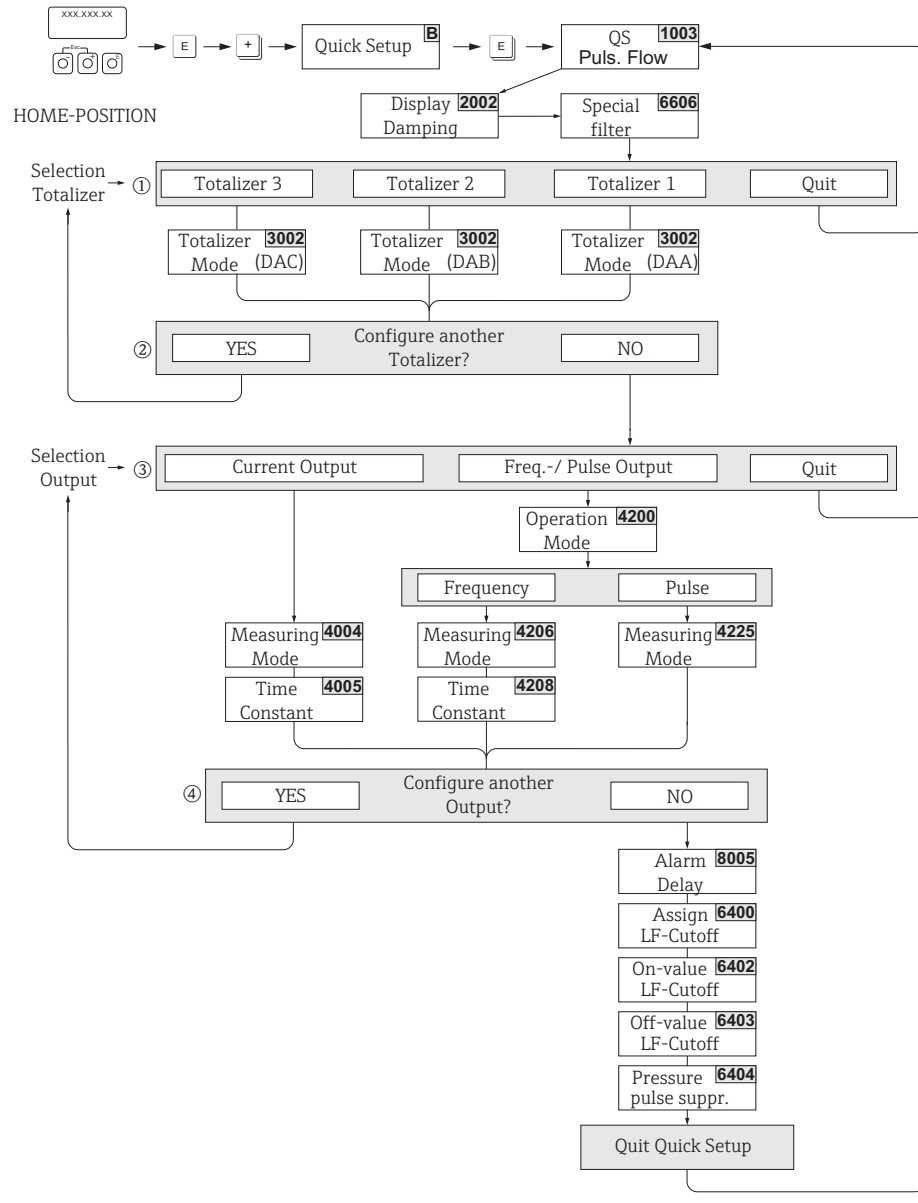



Fig. 57: Quick Setup for measuring severely pulsating flows. Recommended settings → see next page



Note!

- The display returns to the cell QUICK SETUP PULSATING FLOW (1003) if you press the ESC key () during parameter interrogation.
 - You can call up this setup menu either directly from the Commissioning Quick Setup menu or manually by means of the function QUICK SETUP PULSATING FLOW (1003).
 - When this setup is called up, all the parameters of the Quick Setup are reset to the recommended settings (→  69).
- ① Only the output not yet configured in the current setup is offered for selection in the second cycle.
 - ② The "YES" option remains visible until both outputs have been parameterized. "NO" is the only option displayed when no further outputs are available.
 - ③ Only the outputs not yet configured in the current Setup are offered for selection in each cycle.
 - ④ The "YES" option remains visible until all the outputs have been configured. "NO" is the only option displayed when no further outputs are available.

"Pulsating flow" Quick Setup menu		
HOME position → → MEASURED VARIABLE → → QUICK SETUP → → QS PULSATING FLOW (1003)		
Function No.	Function name	Select using Go to next function using
1003	QS-PULS FLOW	YES After is pressed by way of confirmation, the quick setup menu calls up all the subsequent functions in succession.



Basic configuration		
2002	DISPLAY DAMPING	1 s
6606	SPECIAL FILTER	DYNAMIC FLOW
3002	TOTALIZER MODE (DAA)	BALANCE (Totalizer 1)
3002	TOTALIZER MODE (DAB)	BALANCE (Totalizer 2)
3002	TOTALIZER MODE (DAC)	BALANCE (Totalizer 3)
Signal type for "CURRENT OUTPUT 1 to n"		
4004	MEASURING MODE	PULSATING FLOW
4005	TIME CONSTANT	1 s
Signal type for "PULSE/FREQ. OUTPUT 1 to n" (for FREQUENCY operating mode)		
4206	MEASURING MODE	PULSATING FLOW
4208	TIME CONSTANT	0 s
Signal type for "PULSE/FREQ. OUTPUT 1 to n" (for PULSE operating mode)		
4225	MEASURING MODE	PULSATING FLOW
Other settings		
8005	ALARM DELAY	0 s
6400	ASSIGN LOW FLOW CUT OFF	VOLUME FLOW
6402	ON-VALUE LOW FLOW CUT OFF	Recommended setting: $\text{On-value} \approx \frac{\text{max. full scale (per DN)}^*}{1000}$ <small>a0004432-en</small>
6403	OFF-VALUE LOW FLOW CUT OFF	50%
6404	PRESSURE SHOCK SUPPRESSION	0 s



Back to the HOME position
 → Press and hold down Esc keys for longer than three seconds or
 → repeatedly press and release Esc keys → exit the function matrix step by step

6.3.3 Data backup/transmission

Using the T-DAT SAVE/LOAD function, you can transfer data (device parameters and settings) between the T-DAT (exchangeable memory) and the EEPROM (device storage unit).

This is required in the following instances:

- Creating a backup: current data are transferred from an EEPROM to the T-DAT.
- Replacing a transmitter: current data are copied from an EEPROM to the T-DAT and then transferred to the EEPROM of the new transmitter.
- Duplicating data: current data are copied from an EEPROM to the T-DAT and then transferred to EEPROMs of identical measuring points.



Note!

For information on installing and removing the T-DAT → 95.

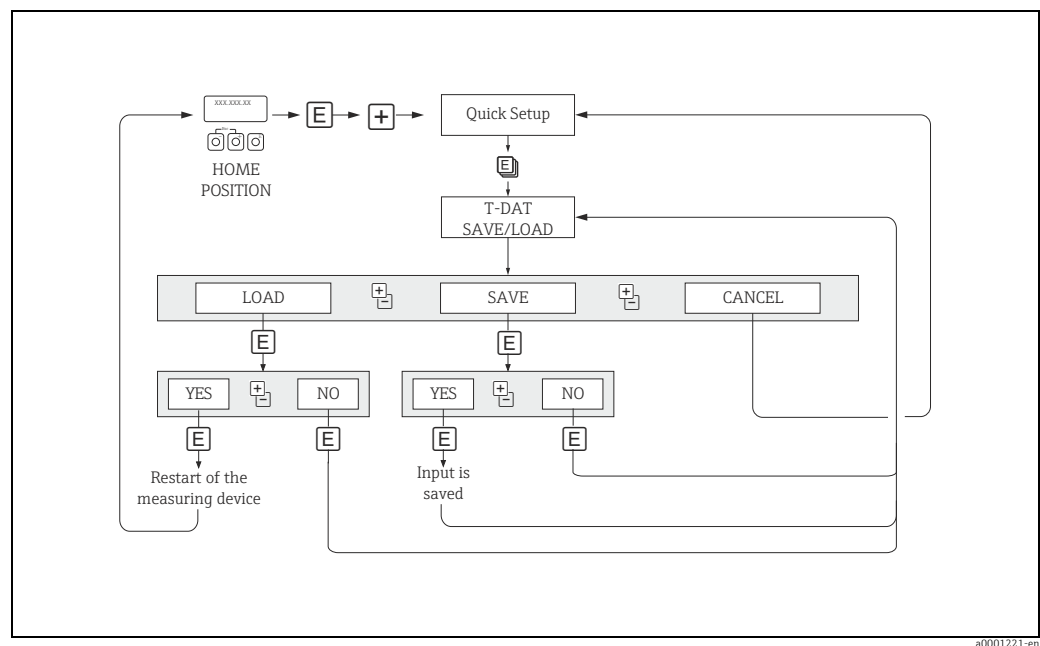

Fig. 58: Data backup/transmission with T-DAT SAVE/LOAD function

Information on the LOAD and SAVE options available:

LOAD: Data are transferred from the T-DAT to the EEPROM.



Note!

- Any settings already saved on the EEPROM are deleted.
- This option is only available, if the T-DAT contains valid data.
- This option can only be executed if the software version of the T-DAT is the same or newer than that of the EEPROM. Otherwise, the error message "TRANSM. SW-DAT" appears after restarting and the LOAD function is then no longer available.

SAVE:

Data are transferred from the EEPROM to the T-DAT.

6.4 Configuration

6.4.1 Current outputs: active/passive

The current outputs can be configured as "active" or "passive" by means of various jumpers on the I/O board or on the current submodule.



Warning!

Risk of electric shock. Exposed components carry dangerous voltages. Make sure that the power supply is switched off before you remove the cover of the electronics compartment.

1. Switch off power supply.
2. Remove the I/O board → 95.
3. Position jumpers → Fig. 52, Fig. 53.



Caution!

- Risk of destroying the measuring device. Set the jumpers exactly as shown in the diagrams. Incorrectly set jumpers can cause overcurrents that would destroy either the measuring device or external devices connected to it.
- Note that the position of the current submodule on the I/O board can vary, depending on the version ordered, and that the terminal assignment in the connection compartment of the transmitter varies accordingly → 40.

4. Installation of the I/O board is the reverse of the removal procedure.

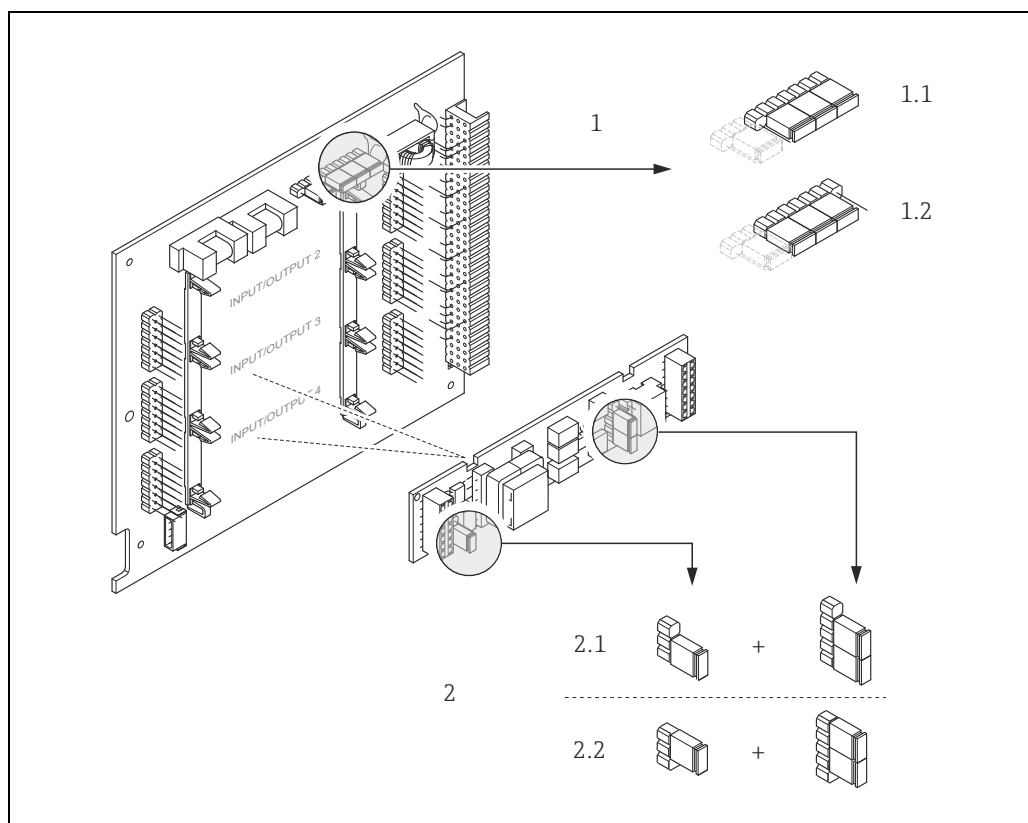
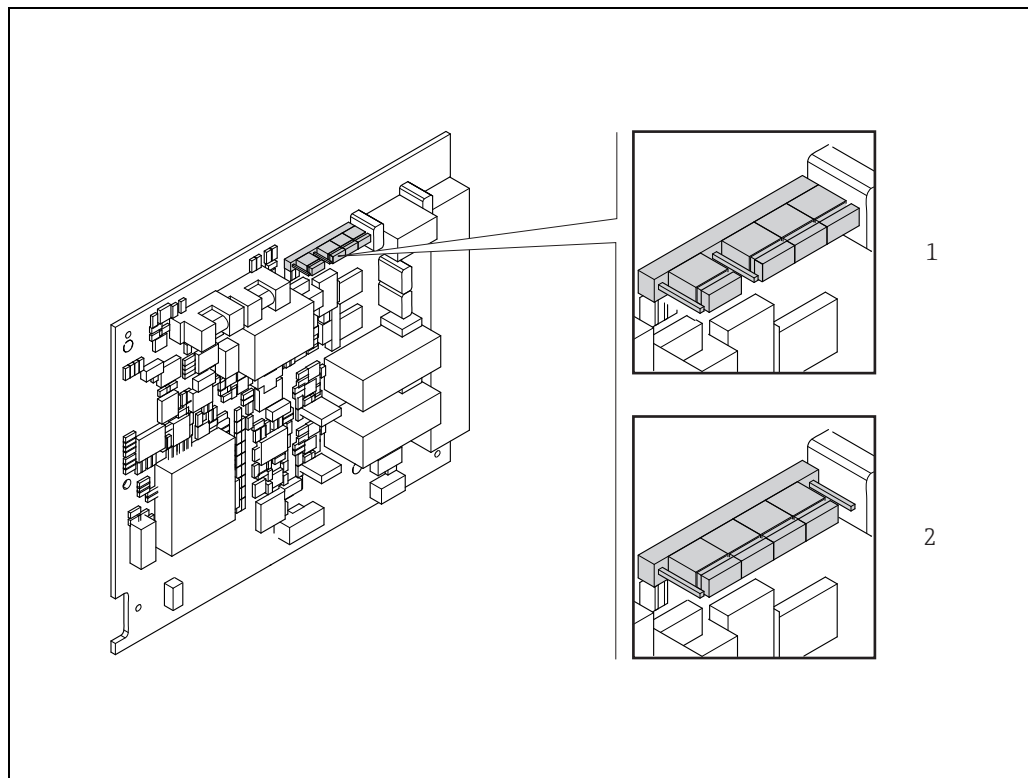

Fig. 59: Configuring the current outputs with the aid of jumpers (convertible I/O board)

- 1 Current output 1 with HART
- 1.1 Active current output (factory setting)
- 1.2 Passive current output
- 2 Current output 2 (optional, plug-in module)
- 2.1 Active current output (factory setting)
- 2.2 Passive current output



a0006361

Fig. 60: Configuring the current output with the aid of jumpers (fixed I/O board)

- 1 Active current output (factory setting)
- 2 Passive current output

6.4.2 Current input: active/passive

The current input can be configured as "active" or "passive" by means of various jumpers on the current input submodule.



Warning!

Risk of electric shock. Exposed components carry dangerous voltages. Make sure that the power supply is switched off before you remove the cover of the electronics compartment.

1. Switch off power supply.
2. Remove the I/O board → 95.
3. Position jumpers → Fig. 54.



Caution!

- Risk of destroying the measuring device. Set the jumpers exactly as shown in the diagram. Incorrectly set jumpers can cause overcurrents that would destroy either the measuring device or external devices connected to it.
 - Note that the position of the current input submodule on the I/O board can vary, depending on the version ordered, and that the terminal assignment in the connection compartment of the transmitter varies accordingly → 40.
4. Installation of the I/O board is the reverse of the removal procedure.

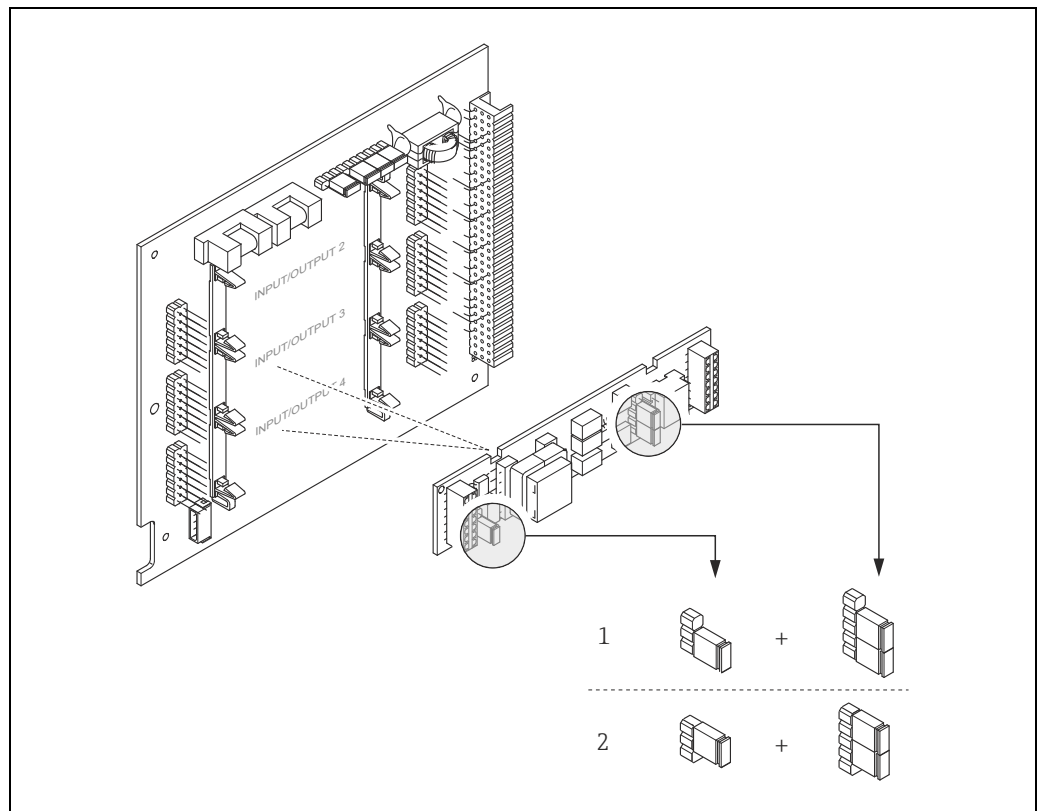

Fig. 61: Configuring the current input with the aid of jumpers (I/O board)

- 1 Active current input (factory setting)
- 2 Passive current input

6.4.3 Relay contacts: Normally closed/normally open

The relay contact can be configured as normally open (NO or make) or normally closed (NC or break) contacts by means of two jumpers on the I/O board or on the relay submodule respectively. This configuration can be called up at any time with the ACTUAL STATUS RELAY function (No. 4740).



Warning!

Risk of electric shock. Exposed components carry dangerous voltages. Make sure that the power supply is switched off before you remove the cover of the electronics compartment.

1. Switch off power supply.
2. Remove the I/O board → 95.
3. Position jumpers → Fig. 55, Fig. 56.



Caution!

- If you change the setting you must always change the positions of **both** jumpers. Set the jumpers exactly as indicated.
- Note that the position of the relay submodule on the I/O board can vary, depending on the version ordered, and that the terminal assignment in the connection compartment of the transmitter varies accordingly → 40.

4. Installation of the I/O board is the reverse of the removal procedure.

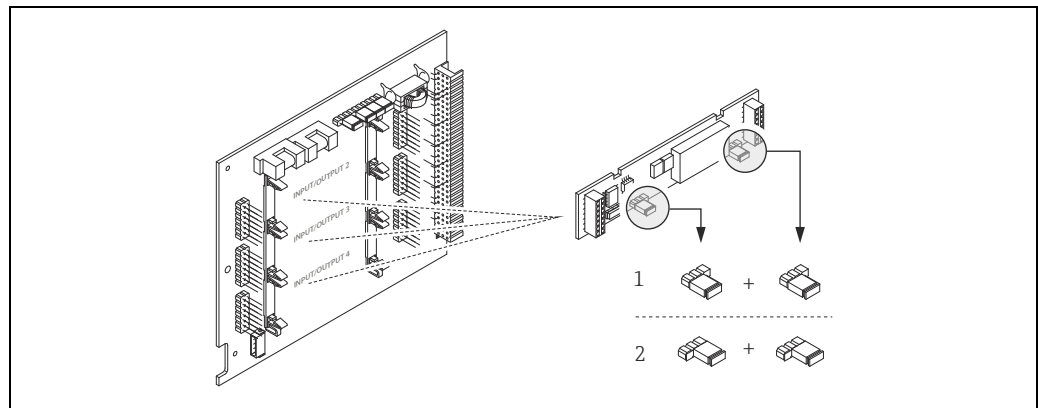

a0001215

Fig. 62: Configuring relay contacts (NC/NO) for the flexible module board.

- 1 Configured as NO contact (factory setting, relay 1)
- 2 Configured as NC contact (factory setting, relay 2, if installed)

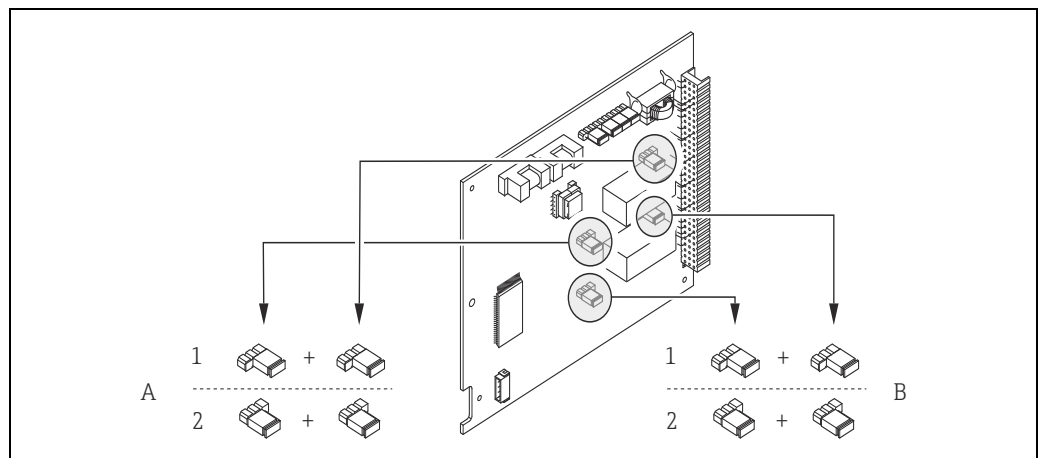

a0001216

Fig. 63: Configuring relay contacts (NC/NO) for the fixed module board.

A = relay 1; B = relay 2

- 1 Configured as NO contact (factory setting, relay 1)
- 2 Configured as NC contact (factory setting, relay 2)

6.4.4 Measuring solids content flow

In certain industrial sectors, raw materials which are very inhomogeneous or which contain considerable amounts of solids, are transported and processed on a daily basis. Ore slurry, mortar or thick pastes are only some examples of this. However, for flow measurement in the mining industry or, for example, in applications using pump dredgers, it is often not just the volume flow in a pipe which is of interest but also the proportion of solid matter being carried along.

To record this solids flow, an electromagnetic flow measurement is usually combined with a radiometric density measurement (total fluid density). If the total fluid density, solid density (target fluid) and the density of the transport liquid (carrier fluid) are known, e.g. as a result of laboratory tests, both the volume flow and mass flow can be calculated in addition to the proportion of individual components in mass, volume or percentage units (Fig. 57).

Solids flow measurements using Promag 55

Promag 55S uses special functions to calculate solids flow. The following preconditions must be met:

- Software option "Solids content flow" (F-CHIP)
- Current input (order option, I/O module no. 4 or 5)
- A density meter, e.g. "Gammapilot M" from Endress+Hauser, for recording total fluid density (i.e. including solids)
- Knowledge of solid density e.g. resulting from laboratory tests
- Knowledge of transport fluid's density, e.g. as a result of laboratory tests or based on tables (e.g. for water at 22 °C)

The following process variables can be calculated using Promag 55 and made available as an output signal:

- Volume flow total fluid (transport liquid + solids)
- Volume flow carrier fluid (transport liquid: e.g. water)
- Volume flow target fluid (solids transported: e.g. stone, sand, lime powder, etc.)
- Mass flow total fluid
- Mass flow carrier fluid
- Mass flow target fluid
- Percentage (%) of carrier fluid (volume or mass)
- Percentage (%) of target fluid (volume or mass)

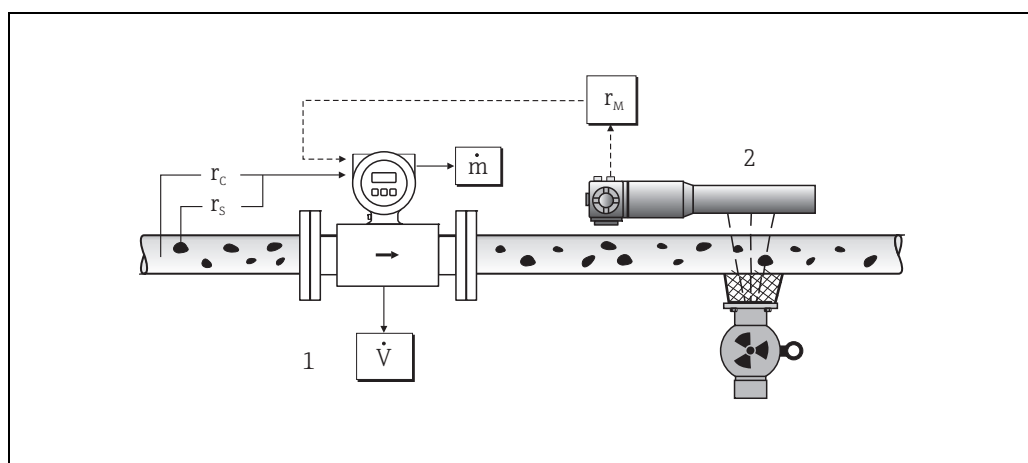

Fig. 64: Solids content flow measurement (\dot{m}) with the aid of a density and flow measuring device. If the solid density (ρ_s) and the density of the carrier liquid (ρ_c) are also known, they can be used to calculate the solids flow.

- 1 Flow measuring device (Promag 55S) \rightarrow volume flow (\dot{V}). The solid density (ρ_s) and the density of the transport liquid (ρ_c) must be entered in the transmitter.
- 2 Density measuring device (e.g. "Gammapilot M") \rightarrow total fluid density (ρ_M) (transport liquid and solids)

Calculation formula (example)

The mass flow of the target fluid is calculated as follows:

$$m_Z = V \cdot (\rho_M - \rho_C) / (1 - \rho_C / \rho_S)$$

m_Z = Mass flow target fluid (solids), e.g. in kg/h

V = Volume flow (total fluid), e.g. in m³/h

ρ_C = Density of carrier fluid (transport liquid: e.g. water)

ρ_S = Density of target fluid (solids transported: e.g. stone, sand, lime powder, etc.)

ρ_M = Total fluid density

Configuration of the "Solids content flow" function

Please note the following points when commissioning the solids content flow function:

1. Make sure that the settings in the following functions for the flowmeter and the external density meter are identical:
 - ASSIGN CURRENT (5200)
 - CURRENT SPAN (5201)
 - VALUE 0_4 mA (5202)
 - VALUE 20 mA (5203)
 - ERROR-VALUE (5204)
 - UNIT DENSITY (0420)
2. Then enter the following density values:
SPECIAL FUNCTIONS > SOLID CONTENT FLOW > CONFIGURATION > CARRIER DENSITY (7711) and TARGET MAT. DENSITY (7712)
3. Enter the desired density unit:
MEASURED VARIABLES > SYSTEM UNITS > ADDITIONAL CONFIGURATION > UNIT DENSITY (0420)
4. If necessary, assign the appropriate solids flow measured variables to a display line or an output (current, frequency, relay). For process control you can also assign user-definable limit values to the solids flow (→ see the following examples).

Case study 1:

You wish to configure the totalizer for totalizing the complete solid mass flow (e.g. in tons).

1. Open the ASSIGN function of the totalizer (> TOTALIZER > CONFIGURATION > ASSIGN).
2. Assign the TARGET MASS FLOW variable to the totalizer.

Case study 2:

You would like to issue a warning message via the relay if the solids flow exceeds 60% of the total mass flow (transport liquid + solids).

1. Open the ASSIGN function of the relay output (> OUTPUTS > RELAY OUTPUT > CONFIGURATION > ASSIGN)
2. To do so, assign the LIMIT TARGET MASS FLOW % variable to the relay output.
3. Then, you can use the ON- or OFF-VALUE function to enter the desired percentage value (%) for the maximum permitted solids flow (e.g. switch on if solid content is 65%; switch off if solid content is 55%).

6.4.5 Advanced diagnostic functions

With the aid of the optional software package "Advanced Diagnostics" (F-CHIP, accessories →  82), changes in the measuring system can be detected early on, e.g. as a result of build-up (coating) or corrosion at the measuring electrodes. Such factors cause a reduction in accuracy under normal circumstances, or cause system errors in extreme cases. With the aid of diagnostic functions it is possible to record different diagnostic parameters during operation – e.g. electrode potential of measuring electrodes 1 and 2, decay time of test pulses at electrodes 1 and 2 (as a measure of possible build-up) etc. By analyzing general trends in these measuring values, deviations in the measuring system relative to a "reference condition" can be detected early on, and the necessary measures can be taken.



Note!
Further information on this can be found in the "Description of Device Functions" manual.

Reference values as a basis for the analysis of general trends

In order to analyze general trends, reference values for the appropriate diagnostic parameters are required. These values must be obtained under reproducible and constant conditions. Such reference values are first recorded during factory calibration and stored in the device. However, reference data should also be collected under customized process conditions, e.g. during commissioning or immediately afterwards. The reference values are always recorded and saved in the measuring system via the REFERENCE STATUS USER (7501) function.



Caution!
It is not possible to analyze general trends in diagnostic parameters without reference values. Reference values should always be obtained immediately after commissioning. This ensures that the reference values saved are values pertaining to the "original condition" of the measuring system i.e. without the influence of any build-up or corrosion.

Type of data collection

Diagnostic parameters can be recorded in two different ways which you can set using the ACQUISITION MODE (7510) function:

- Selection PERIODICAL: Data acquisition is performed periodically by the device. The ACQUISITION PERIOD (7511) function is used to enter the desired time interval.
- Selection MANUAL: Data is collected manually by the user at any chosen points in time.



Note!
The last 10 (via display) or 100 (via FieldCare) recorded diagnostic parameter values are saved chronologically in the measuring system. The "history" of these parameter values can be retrieved using the following functions:

Diagnostic parameters of the function groups*	Saved data records (for each diagnostic parameter)
COATING 1 COATING 2 ELECTRODE POTENTIAL 1 ELECTRODE POTENTIAL 2 VOLUME FLOW NOISE VALUE	Reference value → REFERENCE VALUE function Actual value → ACTUAL VALUE function Lowest measured value → MINIMUM VALUE function Highest measured value → MAXIMUM VALUE function List of the last 10 (or 100) measured values → HISTORY function Measured/reference value deviation → ACTUAL DEVIATION function
*Further information on this can be found in the "Description of Device Functions" manual.	

Triggering warning messages

A limit value may be assigned to all diagnostic parameters if necessary. If this limit value is exceeded, a warning message is triggered → WARNING MODE function (7503).

The limit value is entered into the measuring system as an absolute (+/-) or relative deviation compared to the reference value → WARNING function (75...).

Deviations which occur and which are recorded by the measuring system can also be output via the current or relay outputs.

Data interpretation

The interpretation of the data recorded by the measuring system depends greatly on the application in question. This requires an exact knowledge of the process conditions and the associated deviation tolerances in the process which must be determined individually by the user.

For example, to apply the limit value function (ACTUAL DEVIATION), a knowledge of the permitted minimum and maximum deviation tolerances is particularly important. Otherwise, there is a risk that a warning message could be triggered unintentionally in the event of "normal" process fluctuations.

Deviations from the reference condition may be caused by different factors. The following table shows examples and notes for each of the six recorded diagnostic parameters:

Function group (diagnostic parameters)	Possible causes in the event of deviations from the reference value
COATING 1	A deviation from the reference value may be caused by the following: <ul style="list-style-type: none"> ■ Build-up on measuring electrode 1 ■ Electrical outage ■ Short-circuit
COATING 2	A deviation from the reference value may be caused by the following: <ul style="list-style-type: none"> ■ Build-up on measuring electrode 2 ■ Electrical outage ■ Short-circuit
ELECTRODE POTENTIAL 1	A change in the electrode potential may be caused by the following: <ul style="list-style-type: none"> ■ Corrosion at measuring electrode 1 ■ Greater pH fluctuations in the fluid ■ Presence of air bubbles at measuring electrode 1 ■ Mechanical shock effect on the measuring electrode due to solids ■ Electrical outage ■ Short-circuit
ELECTRODE POTENTIAL 2	A change in the electrode potential may be caused by the following: <ul style="list-style-type: none"> ■ Corrosion at measuring electrode 2 ■ Greater pH fluctuations in the fluid ■ Presence of air bubbles at measuring electrode 2 ■ Mechanical shock effect on the measuring electrode due to solids ■ Electrical outage ■ Short-circuit
VOLUME FLOW	The volume flow is additional information that is needed to assess the other diagnostic parameters sufficiently.
NOISE VALUE	A change in the noise value may be caused by the following: <ul style="list-style-type: none"> ■ Corrosion at the measuring or reference electrode ■ Presence of air bubbles ■ Mechanical shock effect on the measuring electrodes due to solids



Note!

To assess possible build-up, the diagnostic parameters of the COATING 1 and COATING 2 function groups should be interpreted only in combination with those of ELECTRODE POTENTIAL 1 and 2 and VOLUME FLOW. As build-up typically develops over a period of months, it is useful to present and analyze the relevant measurement data and parameters using appropriate software, for example using the Endress+Hauser software packages "FieldCare".

6.5 Adjustment

6.5.1 Empty-pipe/full-pipe adjustment



Caution!

A **detailed** description and other helpful hints for the empty-pipe/full-pipe adjustment procedure can be found in the separate "Description of Device Functions" Manual:

- EPD ADJUSTMENT (6481) → Carrying out the adjustment.
- EPD (6420) → Switching on and off EPD
- EPD RESPONSE TIME (6425) → Input of the response time for EPD



Note!

- The EPD function is not available unless the sensor is fitted with an EPD electrode.
- The devices are already calibrated at the factory using water (approx. 500 µS/cm). If the fluid conductivity differs from this reference, empty-pipe/full-pipe adjustment has to be performed again on site.
- The default setting for the EPD function when the devices are delivered is OFF; the function must be activated if required.
- The EPD process error can be output by means of the configurable relay outputs.

Performing empty-pipe and full-pipe adjustment (EPD)

1. Select the appropriate function in the function matrix:
HOME → → → BASIC FUNCTIONS → → → PROCESSPARAMETER → → → ADJUSTMENT → → EPD ADJUSTMENT
2. Empty the piping. For EPD empty-pipe adjustment, the wall of the measuring tube should be wetted with fluid.
3. Start empty-pipe adjustment: Select "EMPTY PIPE ADJUST" and confirm by pressing .
4. After empty-pipe adjustment, fill the piping with fluid.
5. Start full-pipe adjustment: Select "FULL PIPE ADJUST" and confirm by pressing .
6. Having completed the full-pipe adjustment, select the "OFF" setting and exit the function by pressing .
7. Now select the EPD function (6420). Switch on the empty-pipe detection by selecting ON STANDARD and confirm by pressing .



Caution!

The adjustment coefficients must be valid before you can activate the EPD function. If adjustment is incorrect the following messages might appear on the display:

- FULL = EMPTY
The calibration values for empty pipe and full pipe are identical. In such cases you **must** repeat empty-pipe or full-pipe adjustment.
- ADJUSTMENT NOT OK
Adjustment is not possible because the fluid's conductivity is out of range.

6.6 Data storage devices

At Endress+Hauser, the term HistoROM refers to various types of data storage modules on which process and measuring device data are stored. By plugging and unplugging such modules, device configurations can be duplicated onto other measuring devices to cite just one example.

6.6.1 HistoROM/S-DAT (Sensor DAT)

The S-DAT is an exchangeable data storage device in which all sensor relevant parameters are stored, i.e., diameter, serial number, calibration factor, zero point.

6.6.2 HistoROM/T-DAT (Transmitter DAT)

The T-DAT is an exchangeable data storage device in which all transmitter parameters and settings are stored. Storing of specific parameter settings from the device memory (EEPROM) to the T-DAT module and vice versa must be carried out by the user (= manual save function). Detailed instructions regarding this can be found on →  70.

6.6.3 F-CHIP (Function chip)

The F-CHIP is a microprocessor chip that contains additional software packages that extend the functionality and application possibilities of the transmitter. In the case of a later upgrade, the F-CHIP can be ordered as an accessory and can simply be plugged on to the I/O board. After start up, the software is immediately made available to the transmitter.

Accessories →  82

Plugging into the I/O board →  95



Caution!

To ensure an unambiguous assignment, the F-CHIP is coded with the transmitter serial number once it is plugged into the I/O board. This means that the F-CHIP can not be reused with other measuring devices.

7 Maintenance

No special maintenance work is required.

7.1 Exterior cleaning

When cleaning the exterior of measuring devices, always use cleaning agents that do not attack the surface of the housing and the seals.

7.2 Seals

The seals in the Promag H sensor should be replaced periodically, particularly when molded seals (aseptic version) are used!

The interval between replacements depends on the frequency of the cleaning cycles and on the temperature of the fluid and of the cleaning process.

Replacement seals (accessory) →  82.

8 Accessories

Various accessories, which can be ordered separately or with the device from Endress+Hauser, are available for the device. Detailed information can be provided by the Endress+Hauser service organization or can be found on the product page of the Endress+Hauser website: www.endress.com

8.1 Device-specific accessories

Accessory	Description	Order code
Promag 55 Transmitter	Transmitter for replacement or for stock. Use the order code to define the following specifications: <ul style="list-style-type: none"> ▪ Approvals ▪ Degree of protection / version ▪ Cable type for the remote version ▪ Cable entries ▪ Display / power supply / operation ▪ Software ▪ Outputs / inputs 	55XXX – XXXXX * * * * * * * *
Software packages for Promag 55	Software add-ons on F-CHIP, can be ordered individually: <ul style="list-style-type: none"> ▪ Electrode Cleaning Circuitry (ECC) ▪ Advanced diagnostics ▪ Solids flow 	DK5SO – *
Conversion kit for outputs/inputs	Conversion kit with appropriate plug-in point modules to change the current input/output configuration to a new version.	DK5UI-*

8.2 Measuring principle-specific accessories

Accessory	Description	Order code
Mounting kit for Promag 55 transmitter	Mounting kit for wall-mounted housing (remote version). Suitable for: <ul style="list-style-type: none"> ▪ Wall mounting ▪ Pipe mounting ▪ Installation in control panel Mounting set for aluminum housings. Suitable for: <ul style="list-style-type: none"> ▪ Pipe mounting 	DK5WM – *
Wall-mounting kit for Promag H	Wall-mounting kit for the Promag H sensor	DK5HM – **
Cable for remote version	Coil current and electrode cables, various lengths. Reinforced cable on request.	DK5CA – **
Ground cable for Promag S	A set consists of two ground cables.	DK5GC – ***
Ground disk/liner protection plate for Promag S	Metal disk for potential equalization and/or for protecting the measuring tube lining.	DK5GD – ***
Mounting kit for Promag H	Mounting kit for Promag H, comprising: <ul style="list-style-type: none"> ▪ 2 process connections ▪ Threaded fasteners ▪ Seals 	DKH ** – * * * *
Set of seals for Promag H	For regular replacement of the seals of the Promag H sensor.	DK5HS – ***
Welding jig for Promag H	Weld nipple as process connection: welding jig for installation in pipe.	DK5HW – ***

Accessory	Description	Order code
Adapter connection for Promag H	Adapter connections for installing Promag 55H instead of Promag 30/33A or Promag 30/33H / DN 25.	DK5HA – * * * * *
Ground rings for Promag H	If the process connections are made of PVC or PVDF, ground rings are necessary to ensure that potential is matched. Set of ground rings, comprising: <ul style="list-style-type: none"> ▪ 2 ground rings 	DK5HR – * * * *
Extension piece	Extension piece for installation of Promag 55 H instead of Promag 35 S.	DK5SP

8.3 Communication-specific accessories

Accessory	Description	Order code
HART Communicator Field Xpert SFX 100	Handheld terminal for remote configuration and for obtaining measured values via the 4 to 20 mA HART current output. Contact your Endress+Hauser representative for more information.	SFX100 – * * * * *
FXA195	The Commubox FXA195 connects intrinsically safe Smart transmitters with HART protocol to the USB port of a personal computer. This makes the remote operation of the transmitters possible with the aid of configuration programs (e.g. FieldCare). Power is supplied to the Commubox by means of the USB port	FXA195 – *

8.4 Communication-specific accessories

Accessory	Description	Order code
Applicator	Software for selecting and configuring flowmeters. Applicator can be downloaded from the Internet or ordered on CD-ROM for installation on a local PC. Contact your Endress+Hauser representative for more information.	DKA80 – *
Fieldcheck	Tester/simulator for testing flowmeters in the field. When used in conjunction with the "FieldCare" software package, test results can be imported into a database, printed and used for official certification. Contact your Endress+Hauser representative for more information.	50098801
FieldCare	FieldCare is Endress+Hauser's FDT-based plant asset management tool. It can configure all intelligent field devices in your plant and supports you in the administration of these devices. Through the use of status information, it is also an easy but effective means of monitoring the status of these devices.	See product list on the Endress+Hauser website: www.endress.com
FXA193	Service interface of device to the PC for operation via FieldCare.	FXA193 – *

Accessory	Description	Order code
Memograph M graphic display recorder	<p>The Memograph M graphic display recorder provides information on all relevant process variables:</p> <p>Measuring values are recorded reliably, limit values monitored and measuring points analyzed. The data are stored in the 256 MB internal memory and also on an SD card or USB stick.</p> <p>The PC software package ReadWin® 2000, which is supplied as standard, is used for configuration, visualization and storage of the recorded data.</p>	RSG40 - * * * * * * * * * * * * * *

9 Troubleshooting

9.1 Troubleshooting

Always start troubleshooting with the checklist below, if faults occur after startup or during operation. The routine takes you directly to the cause of the problem and the appropriate remedial measures.



Caution!

In the event of a serious fault, a flowmeter might have to be returned to the manufacturer for repair. The necessary procedures must be carried out before you return the device to Endress+Hauser → 5.

Always enclose a duly completed "Declaration of Contamination" form. You will find a preprinted blank of this form at the back of this manual.

Check the display	
No display visible and no output signals present.	<ol style="list-style-type: none"> 1. Check the power supply → terminals 1, 2 2. Check device fuse → 99 20 to 260 V AC and 20 to 64 V DC: 2 A slow-blow / 250 V 3. Measuring electronics defective → order spare parts → 94
No display visible, but output signals are present.	<ol style="list-style-type: none"> 1. Check whether the ribbon-cable connector of the display module is correctly plugged into the amplifier board → 94, 2. Display module defective → order spare parts → 94 3. Measuring electronics defective → order spare parts → 94
Display texts are in a foreign language.	Switch off power supply. Then press the keys simultaneously to switch the device back on. The display text will appear in English (default) and is displayed at maximum contrast.
Measured value indicated, but no signal at the current or pulse output	Measuring electronics defective → order spare parts → 94



Error messages on display	
Errors which occur during commissioning or measuring operation are displayed immediately. Error messages consist of a variety of icons. The meanings of these icons are as follows (example): <ul style="list-style-type: none"> ▪ Error type: S = system error, P = process error ▪ Error message type: = fault message, ! = notice message ▪ EMPTY PIPE = Type of error, e.g. measuring tube is only partly filled or completely empty ▪ 03:00:05 = duration of error occurrence (in hours, minutes and seconds) ▪ #401 = error number 	
Caution! <ul style="list-style-type: none"> ▪ Also observe the information on → 51 ▪ The measuring system interprets simulations and positive zero return as system errors, but displays them as notice message only. 	
Error number: No. 001 – 399 No. 501 – 699	System error (device error) has occurred → 86
Error number: No. 401 – 499	Process error (application error) has occurred → 90



Other error (without error message)	
Some other error has occurred.	Diagnosis and rectification → 90

9.2 System error messages

Serious system errors are **always** recognized by the instrument as "Fault message", and are shown as a lightning flash (⚡) on the display. Fault messages immediately affect the inputs and outputs. Simulations and positive zero return, on the other hand, are classed and displayed as notice messages.



Caution!

In the event of a serious fault, a flowmeter might have to be returned to the manufacturer for repair. The necessary procedures must be carried out before you return the device to Endress+Hauser → 100.



Always enclose a duly completed "Declaration of contamination" form. You will find a preprinted blank of the this form at the back of this manual.



Note!

- The error types listed in the following correspond to the factory settings.
- See also the information on → 51.

No.	Error message / Type	Cause	Remedy / spare part → 94ff
S = System error ⚡ = Fault message (with an effect on the outputs) ! = Notice message (without an effect on the outputs)			
No. # 0xx → Hardware error			
001	S: CRITICAL FAIL. ⚡: # 001	Serious device error	Replace the amplifier board.
011	S: AMP HW EEPROM ⚡: # 011	Amplifier: Defective EEPROM	Replace the amplifier board.
012	S: AMP SW EEPROM ⚡: # 012	Amplifier: Error accessing EEPROM data	The EEPROM data blocks in which an error has occurred are displayed in the TROUBLESHOOTING function (No. 8047). Press Enter to acknowledge the errors in question; default values are automatically inserted instead of the error parameter values. Note! The measuring device must be restarted after fault elimination.
031	S: SENSOR HW DAT ⚡: # 031	Sensor DAT: 1. S DAT is not correctly plugged into the amplifier board (or is missing). 2. S-DAT is defective.	1. Check whether the S-DAT is correctly plugged into the amplifier board, 2. Replace the S-DAT if it is defective. Spare parts → 94 Check whether the new replacement DAT is compatible with the existing electronics. Check the: – Spare part set number – Hardware revision code 3. Replace measuring electronics boards if necessary. 4. Plug the S-DAT into the amplifier board.
032	S: SENSOR SW DAT ⚡: # 032	Sensor DAT: Error accessing the calibration values stored in the S-DAT.	

No.	Error message / Type	Cause	Remedy / spare part → 94ff
041	S: TRANSM. HW-DAT ⚡: # 041	Transmitter DAT: 1. T DAT is not correctly plugged into the amplifier board (or is missing). 2. T-DAT is defective.	1. Check whether the T-DAT is correctly plugged into the amplifier board. 2. Replace the T-DAT if it is defective. Check whether the new replacement DAT is compatible with the existing electronics. Check the: – Spare part set number – Hardware revision code
042	S: TRANSM. SW-DAT ⚡: # 042	Transmitter DAT: Error accessing the calibration values stored in the S-DAT.	3. Replace measuring electronics boards if necessary. 4. Plug the T-DAT into the amplifier board.
061	S: HW F-CHIP ⚡: # 061	Transmitter F-CHIP: 1. F-CHIP is defective. 2. F-CHIP is not plugged into the I/O board or is missing.	1. Replace the F-CHIP. Accessories → 82 2. Plug the F-CHIP into the I/O board → 95
No. # 1xx → Software error			
101	S: GAIN ERROR AMP. ⚡: # 101	Gain deviation compared to reference gain is greater than 2%.	Replace the amplifier board. Spare parts → 94
121	S: A/C COMPATIB !: # 121	Due to different software versions, I/O board and amplifier board are only partially compatible (possibly restricted functionality).  Note! ▪ This message is listed only in the error history. ▪ Nothing shown on display.	Module with lower software version must either be updated by FieldCare using the required (recommended) software version, or the module must be replaced.
No. # 2xx → Error in DAT / no communication			
205	S: LOAD T-DAT !: # 205	Transmitter DAT: Data backup (downloading) to T-DAT failed, or error when accessing (uploading) the calibration values stored in the T-DAT.	1. Check whether the T-DAT is correctly plugged into the amplifier board → 95 2. Replace the T-DAT if it is defective. Spare parts → 94 Before replacing the DAT, check that the new, replacement DAT is compatible with the measuring electronics. Check the: – Spare part set number – Hardware revision code 3. Replace measuring electronics boards if necessary.
206	S: SAVE T-DAT !: # 206		
261	S: COMMUNICATION I/O ⚡: # 261	No data reception between amplifier and I/O board or faulty internal data transfer.	Check the BUS contacts
No. # 3xx → System limits exceeded			
321	S: TOL. COIL CURR. ⚡: # 321	Sensor: Coil current is out of tolerance.	 Warning! Switch off power supply before manipulating the coil current cable, coil current cable connector or measuring electronics boards! Remote version: 1. Check wiring of terminals 41/42 → 40 2. Check coil current cable connector. Compact and remote version: Replace measuring electronics boards if necessary

No.	Error message / Type	Cause	Remedy / spare part → 94ff
339 to 342	S: STACK CURRENT OUTPUT n !: # 339 to 342	The temporarily buffered flow portions (measuring mode for pulsating flow) could not be cleared or output within 60 seconds.	1. Change the upper or lower limit setting, as applicable. 2. Increase or reduce flow, as applicable. Recommendations in the event of fault category = FAULT MESSAGE (!): - Configure the fault response of the output to "ACTUAL VALUE", so that the temporary buffer can be cleared → 92 - Clear the temporary buffer by the measures described under Item 1.
343 to 346	S: STACK FREQUENCY OUTPUT n \$: # 343 to 346		
347 to 350	S: STACK PULS OUTPUT n !: # 347 to 350	The temporarily buffered flow portions (measuring mode for pulsating flow) could not be cleared or output within 60 seconds.	1. Increase the setting for pulse value. 2. Increase the max. pulse frequency, if the totalizer can handle a higher number of pulses. 3. Increase or reduce flow, as applicable. Recommendations in the event of fault category = FAULT MESSAGE (\$): - Configure the fault response of the output to "ACTUAL VALUE", so that the temporary buffer can be cleared → 92 - Clear the temporary buffer by the measures described under Item 1.
351 to 354	S: CURRENT RANGE n !: # 351 to 354	Current output: Actual flow value is out of range.	1. Change the upper or lower limit setting, as applicable. 2. Increase or reduce flow, as applicable.
355 to 358	S: FREQ. RANGE n !: # 355 to 358	Frequency output: Actual flow value is out of range.	1. Change the upper or lower limit setting, as applicable. 2. Increase or reduce flow, as applicable.
359 to 362	S: PULSE RANGE !: # 359 to 362	Pulse output: The pulse output frequency is outside the permitted range.	1. Increase the setting for pulse weighting 2. When entering the pulse width, select a value that can still be processed by an external totalizer (e.g. mechanical totalizer, PLC, etc.). <i>Determine the pulse width:</i> - Version 1: Enter the minimum duration that a pulse must be present at the connected counter to ensure its registration. - Version 2: Enter the maximum (pulse) frequency as the half "reciprocal value" that a pulse must be present at the connected counter to ensure its registration. Example: The maximum input frequency of the external totalizer is 10 Hz. The pulse width to be entered is: $\frac{1}{2 \cdot 10 \text{ Hz}} = 50 \text{ ms}$ 3. Reduce flow.

a0004437

No.	Error message / Type	Cause	Remedy / spare part → 94ff
363	S: RANGE CUR. IN !: # 363	Current input: Actual current value is out of range.	1. Change the upper or lower limit setting, as applicable. 2. Check the settings of the external sensor.
No. # 5xx → Application error			
501	S: SW.-UPDATE ACT. !: # 501	New amplifier or communication module software version is being loaded to the device. Currently no other functions are possible.	Wait until the procedure is finished. The device is restarted automatically.
502	S: UP-/DOWNLOAD ACT. !: # 502	Up- or downloading the device data via configuration program. Currently no other functions are possible.	Wait until the procedure is finished. The device is restarted automatically.
No. # 6xx → Simulation mode active			
601	S: POS. ZERO-RETURN !: # 601	Positive zero return active  Caution! This message has the highest display priority!	Switch off positive zero return
611 to 614	S: SIM. CURR. OUT. n !: # 611 to 614	Simulation current output active	Switch off simulation
621 to 624	S: SIM. FREQ. OUT. n !: # 621 to 624	Simulation frequency output active	Switch off simulation
631 to 634	S: SIM. PULSE n !: # 631 to 634	Simulation pulse output active	Switch off simulation
641 to 644	S: SIM. STAT. OUT n !: # 641 to 644	Simulation status output active	Switch off simulation
651 to 654	S: SIM. RELAY n !: # 651 to 654	Simulation relay output active	Switch off simulation
661 to 664	S: SIM. CURR. IN n !: # 661 to 664	Simulation current input active	Switch off simulation
671 to 674	S: SIM. STATUS IN n !: # 671 to 674	Simulation status input active	Switch off simulation
691	S: SIM. FAILSAFE !: # 691	Simulation of response to error (outputs) active	Switch off simulation
692	S: SIM. MEASURAND !: # 692	Simulation of a measurand is active (e.g. mass flow)	Switch off simulation
698	S: DEV. TEST ACT. !: # 698	The measuring device is currently being checked on site via the test and simulation device.	–
No. # 8xx → Other error messages with software options			
840	S: COAT. E1 DEV. LIM !: # 840	The decay time constant is outside the range defined in the WARNING function (7536).	Remove the sensor from the pipe, and check if the inner wall of the measuring tube needs to be cleaned.
841	S: COAT. E2 DEV. LIM !: # 841	The decay time constant is outside the range defined in the WARNING function (7546).	Remove the sensor from the pipe, and check if the inner wall of the measuring tube needs to be cleaned.

No.	Error message / Type	Cause	Remedy / spare part →  94ff
845	S: COATING FAILED !: # 845	Coating detection is not possible: 1. The set value for the corresponding recovery time is too small. 2. The measuring tube is empty or only partially filled.	1. Increase value for the recovery time (→ RECOVERY TIME function, 7523). 2. Fill the measuring tube (check the process conditions of the plant if necessary).
846	S: NOI.VAL. DEV. LIM !: # 846	The deviation of the noise values outside the range defined in the WARNING function (7586).	Check your application for changes in the process (pressure, bubbles, inhomogeneity).

9.3 Process error messages

Process errors can be defined as either "Fault" or "Notice" messages and can thereby be weighted differently. Determination of this is done via the function matrix (see the "Description of Device Functions" Manual).





Note!

- The error types listed in the following correspond to the factory settings.
- See also the information on →  51.

No.	Error message / Type	Cause	Remedy / spare part
P = Process error \$ = Fault message (with an effect on the inputs/outputs) ! = Notice message (without an effect on the inputs/outputs)			
No. # 4xx → Process limits exceeded			
401	P: EMPTY PIPE \$: # 401	Measuring tube partially filled or empty	1. Check the process conditions of the plant 2. Fill the measuring tube
461	P: ADJ. NOT OK \$: # 461	EPD adjustment not possible because the fluid's conductivity is either too low or too high.	The EPD function cannot be used with fluids of this nature.
463	P: FULL = EMPTY \$: # 463	The EPD adjustment values for empty pipe and full pipe are identical and therefore incorrect.	Repeat adjustment, making sure procedure is correct →  79

9.4 Process errors without message

Symptoms	Rectification
 Note! You may have to change or correct certain settings in functions in the function matrix in order to rectify the fault. The functions outlined below, such as DISPLAY DAMPING, are described in detail in the "Description of Device Functions" manual.	
Flow values are negative, even though the fluid is flowing forwards through the pipe.	1. Remote version: - Switch off the power supply and check the wiring →  33 - If necessary, reverse the connections at terminals 41 and 42 2. Change the setting in the INSTALLATION DIRECTION SENSOR function accordingly

Symptoms	Rectification
Measured-value reading fluctuates even though flow is steady.	<ol style="list-style-type: none"> 1. Check grounding and potential equalization → 42 2. The medium is too inhomogeneous. Check the following medium characteristics: <ul style="list-style-type: none"> – Gas bubble percentage too high? – Solids percentage too high? – Conductivity fluctuations too high? 3. SYSTEM DAMPING function → increase value (→ BASIC FUNCTION/ SYSTEMPARAMETER/CONFIGURATION) 4. TIME CONSTANT function → increase value (→ OUTPUTS/CURRENT OUTPUT/CONFIGURATION) 5. DISPLAY DAMPING function → increase value (→ USER INTERFACE / CONTROL/BASIC CONFIGURATION)
Measured-value reading or measured-value output pulsates or fluctuates, e.g. because of reciprocating pump, peristaltic pump, diaphragm pump or pump with similar delivery characteristic.	<p>Run the "Pulsating flow" Quick Setup → 67</p> <p>If the problem persists despite these measures, a pulsation damper will have to be installed between pump and measuring device.</p>
There are differences between the flowmeter's internal totalizer and the external metering device.	<p>This symptom is due primarily to backflow in the piping, because the pulse output cannot subtract in the STANDARD or SYMMETRY measuring modes.</p> <p>There is the following solution:</p> <p>The flow in both directions should be taken into account. Set the MEASURING MODE function to PULSATING FLOW for the pulse output in question.</p>
Measured-value reading shown on display, even though the fluid is at a standstill and the measuring tube is full.	<ol style="list-style-type: none"> 1. Check grounding and potential equalization → 42 2. Check the fluid for presence of gas bubbles. 3. Activate ON-VALUE LOW FLOW CUT OFF function, i.e. enter or increase on value (→ BASIC FUNCTION/PROCESSPARAMETER/ CONFIGURATION).
Measured-value reading on display, even though measuring tube is empty.	<ol style="list-style-type: none"> 1. Perform empty-pipe/full-pipe adjustment and then switch on empty pipe detection → 79 2. Remote version: Check the terminals of the EPD cable → 34 3. Fill the measuring tube.
The current output signal is always 4 mA, irrespective of the flow signal at any given time.	<ol style="list-style-type: none"> 1. Select the BUS ADDRESS function and change the setting to "0". 2. Low flow cutoff too high → reduce the relevant value in the ON-VALUE LOW FLOW CUT OFF function.
The fault cannot be rectified or some other fault not described above has arisen. In these instances, please contact your Endress+Hauser service organization.	<p>The following options are available for tackling problems of this nature:</p> <ul style="list-style-type: none"> ■ Request the services of an Endress+Hauser service technician If you contact our service organization to have a service technician sent out, please be ready to quote the following information: <ul style="list-style-type: none"> – Brief description of the fault – Nameplate specifications: order code and serial number → 6 ■ Returning devices to Endress+Hauser The necessary procedures must be carried out before you return a flowmeter requiring repair or calibration to Endress+Hauser → 100. Always enclose a duly completed "Declaration of contamination" form with the flowmeter. You will find a preprinted form at the back of this manual. ■ Replace transmitter electronics Components in the measuring electronics defective → order spare parts → 94



9.5 Response of outputs to errors



Note!

The failsafe mode of current, pulse and frequency outputs can be customized by means of various functions in the function matrix. You will find detailed information on these procedures in the "Description of Device Functions" manual.

You can use positive zero return to reset the signals of the current, pulse and frequency outputs to their fallback value, for example when measuring has to be interrupted while a pipe is being cleaned. This function takes priority over all other device functions: simulations, for example, are suppressed.

Error response mode of outputs		
	System/process error is current	Positive zero return is activated
<p> Caution! System or process errors defined as "Notice messages" have no effect whatsoever on the inputs and outputs. See the information on →  51</p>		
Current output	<p><i>MINIMUM VALUE</i> 0-20 mA → 0 mA 4-20 mA → 2 mA 4-20 mA HART → 2 mA 4-20 mA NAMUR → 3.5 mA 4-20 mA HART NAMUR → 3.5 mA 4-20 mA US → 3.75 mA 4-20 mA HART US → 3.75 mA 0-20 mA (25 mA) → 0 mA 4-20 mA (25 mA) → 2 mA 4-20 mA (25 mA) HART → 2 mA</p> <p><i>MAXIMUM VALUE</i> 0-20 mA → 22 mA 4-20 mA → 22 mA 4-20 mA HART → 22 mA 4-20 mA NAMUR → 22.6 mA 4-20 mA HART NAMUR → 22.6 mA 4-20 mA US → 22.6 mA 4-20 mA HART US → 22.6 mA 0-20 mA (25 mA) → 25 mA 4-20 mA (25 mA) → 25 mA 4-20 mA (25 mA) HART → 25 mA</p> <p><i>HOLD VALUE</i> Last valid value (preceding occurrence of the fault) is output.</p> <p><i>ACTUAL VALUE</i> Fault is ignored, i.e. normal measured-value output on the basis of ongoing flow measurement.</p>	Output signal corresponds to "zero flow"
Pulse output	<p><i>FALLBACK VALUE</i> Signal output → no pulses</p> <p><i>HOLD VALUE</i> Last valid value (preceding occurrence of the fault) is output.</p> <p><i>ACTUAL VALUE</i> Fault is ignored, i.e. normal measured-value output on the basis of ongoing flow measurement.</p>	Output signal corresponds to "zero flow"

Error response mode of outputs		
	System/process error is current	Positive zero return is activated
Frequency output	<p>FALLBACK VALUE Signal output → 0 Hz</p> <p>FAILSAFE LEVEL Output of the frequency specified in the FAILSAFE VALUE function (4211).</p> <p>HOLD VALUE Last valid value (preceding occurrence of the fault) is output.</p> <p>ACTUAL VALUE Fault is ignored, i.e. normal measured-value output on the basis of ongoing flow measurement.</p>	Output signal corresponds to "zero flow"
Totalizer	<p>STOP The totalizers are paused until the fault is rectified.</p> <p>ACTUAL VALUE The fault is ignored . The totalizers continue to count in accordance with the current flow value.</p> <p>HOLD VALUE The totalizers continue to count the flow in accordance with the last valid flow value (before the error occurred).</p>	Totalizer stops
Relay output	<p>Fault or power supply failure: relay → de-energized</p> <p>In the "Description of Device Functions" manual you will find detailed information on relay switching response for various configurations such as error message, flow direction, EPD, limit value, etc.</p>	No effect on relay output

9.6 Spare parts

You will find detailed troubleshooting instructions in the preceding sections → 85. The measuring device, moreover, provides additional support in the form of continuous self-diagnosis and error messages.

Fault rectification can entail replacing defective components with tested spare parts. The illustration below shows the available scope of spare parts.



Note!

You can order spare parts directly from your Endress+Hauser service organization by providing the serial number printed on the transmitter nameplate → 6.

Spare parts are shipped as sets comprising the following parts:

- Spare part
- Additional parts, small items (threaded fasteners, etc.)
- Mounting instructions
- Packaging

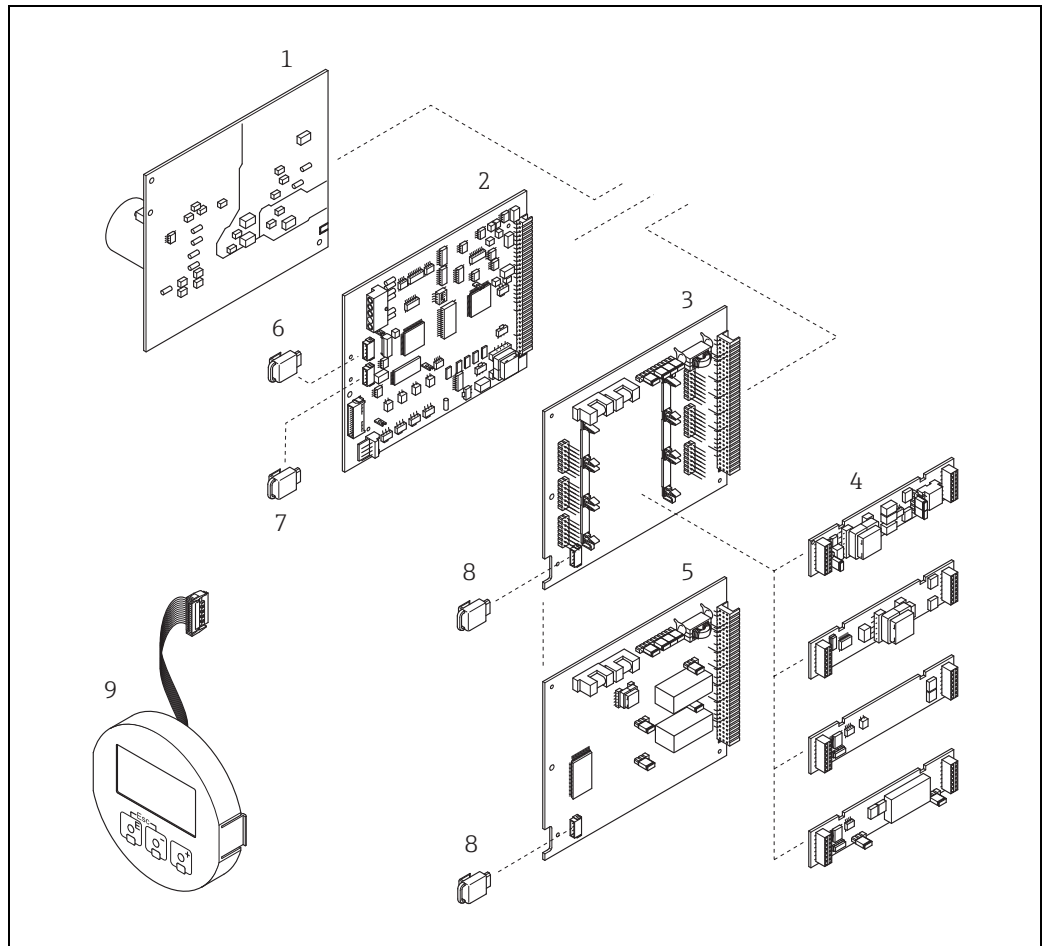

Fig. 65: Spare parts for Promag transmitter (field and wall-mount housing)

- 1 Power unit board (20 to 260 V AC, 20 to 64 V DC)
- 2 Amplifier board
- 3 I/O board (COM module), flexible assignment
- 4 Pluggable input/output submodules; product structure → 82
- 5 I/O board (COM module), permanent assignment
- 6 S-DAT (sensor data storage device)
- 7 T-DAT (transmitter data storage device)
- 8 F-CHIP (function chip for optional software)
- 9 Display module

9.6.1 Removing and installing printed circuit boards

Field housing



Warning!

- Risk of electric shock. Exposed components carry dangerous voltages. Make sure that the power supply is switched off before you remove the cover of the electronics compartment.
- Risk of damaging electronic components (ESD protection). Static electricity can damage electronic components or impair their operability. Use a workplace with a grounded working surface purpose-built for electrostatically sensitive devices!
- If you cannot guarantee that the dielectric strength of the device is maintained in the following steps, then an appropriate inspection must be carried out in accordance with the manufacturer's specifications.



Caution!

Use only original Endress+Hauser parts.

Removing and installing the boards → 96:

1. Unscrew cover of the electronics compartment from the transmitter housing.
2. Remove the local display (1) as follows:
 - Press in the latches (1.1) at the side and remove the display module.
 - Disconnect the ribbon cable (1.2) of the display module from the amplifier board.
3. Remove the screws and remove the cover (2) from the electronics compartment.
4. Removing power unit board (4) and I/O board (6, 7):
Insert a thin pin into the hole provided (3) and pull the board clear of its holder.
5. Removing submodules (6.2, only for devices with flexibly assigned I/O board):
No additional tools are required for removing the submodules (inputs/outputs) from the I/O board or plugging them into it.



Caution!

Only certain combinations of submodules on the I/O board are permissible → 40.
The individual slots are marked and correspond to certain terminals in the connection compartment of the transmitter:

- Slot "INPUT/OUTPUT 2" = Terminals 24/25
- Slot "INPUT/OUTPUT 3" = Terminals 22/23
- Slot "INPUT/OUTPUT 4" = Terminals 20/21

6. Remove amplifier board (5):
 - Disconnect the plug of the electrode cable (5.1) including S-DAT (5.3) from the board.
 - Loosen the plug locking of the coil current cable (5.2) and gently disconnect the plug from the board, i.e. without moving it to and fro.
 - Insert a thin pin into the hole provided (3) and pull the board clear of its holder.
7. Installation is the reverse of the removal procedure.

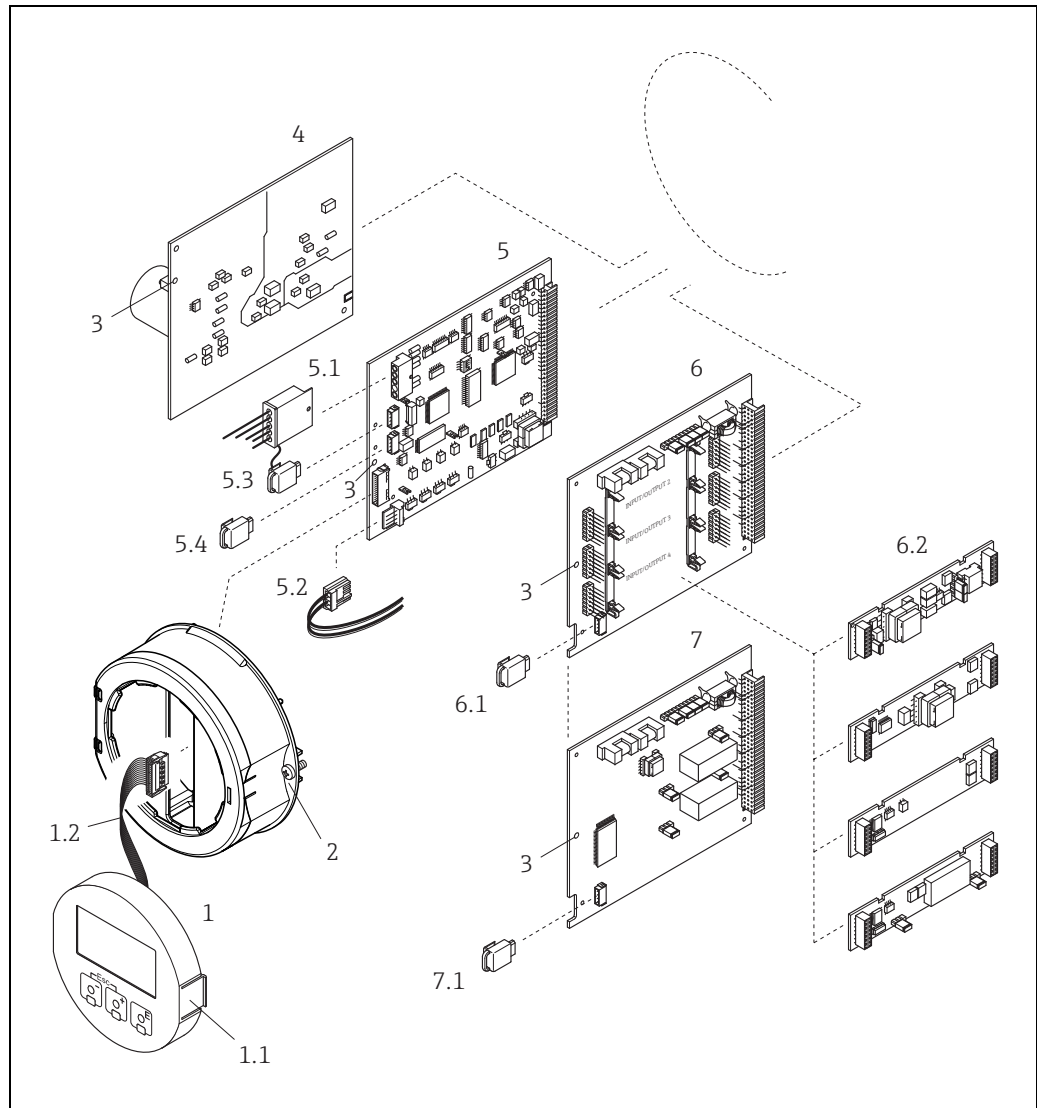

a0002656

Fig. 66: Field housing: removing and installing printed circuit boards

- 1 Local display
- 1.1 Latch
- 1.2 Ribbon cable (display module)
- 2 Screws for electronics compartment cover
- 3 Aperture for installing /removing boards
- 4 Power unit board
- 5 Amplifier board
- 5.1 Electrode cable (sensor)
- 5.2 Coil current cable (sensor)
- 5.3 S-DAT (sensor data storage device)
- 5.4 T-DAT (transmitter data storage device)
- 6 I/O board (flexible assignment)
- 6.1 F-CHIP (function chip for optional software)
- 6.2 Pluggable submodules (inputs/outputs)
- 7 I/O boards (permanent assignment)
- 7.1 F-CHIP (function chip for optional software)

Wall-mount housing



Warning!

- Risk of electric shock. Exposed components carry dangerous voltages. Make sure that the power supply is switched off before you remove the cover of the electronics compartment.
- Risk of damaging electronic components (ESD protection). Static electricity can damage electronic components or impair their operability. Use a workplace with a grounded working surface purpose-built for electrostatically sensitive devices!
- If you cannot guarantee that the dielectric strength of the device is maintained in the following steps, then an appropriate inspection must be carried out in accordance with the manufacturer's specifications.



Caution!

Use only original Endress+Hauser parts.

Installing and removing the boards →  98:

1. Remove the screws and open the hinged cover (1) of the housing.
2. Loosen the screws securing the electronics module (2). Then push up electronics module and pull it as far as possible out of the wall-mounted housing.
3. Disconnect the following cable plugs from amplifier board (7):
 - Electrode cable plug (7.1) including S-DAT (7.3)
 - Plug of coil current cable (7.2): To do so, loosen the plug locking of the coil current cable (5.2) and carefully disconnect the plug from the board, i.e. without moving it to and fro.
 - Ribbon cable plug (3) of the display module
4. Remove the cover (4) from the electronics compartment by loosening the screws.
5. Removing boards (6, 7, 8):
Insert a thin pin into the hole provided (5) and pull the board clear of its holder.
6. Removing submodules (8.2, only for devices with flexibly assigned I/O board):
No additional tools are required for removing the submodules (inputs/outputs) from the I/O board or plugging them into it.



Caution!

Only certain combinations of submodules on the I/O board are permissible →  40.
The individual slots are marked and correspond to certain terminals in the connection compartment of the transmitter:

- Slot "INPUT/OUTPUT 2" = Terminals 24/25
- Slot "INPUT/OUTPUT 3" = Terminals 22/23
- Slot "INPUT/OUTPUT 4" = Terminals 20/21

7. Installation is the reverse of the removal procedure.

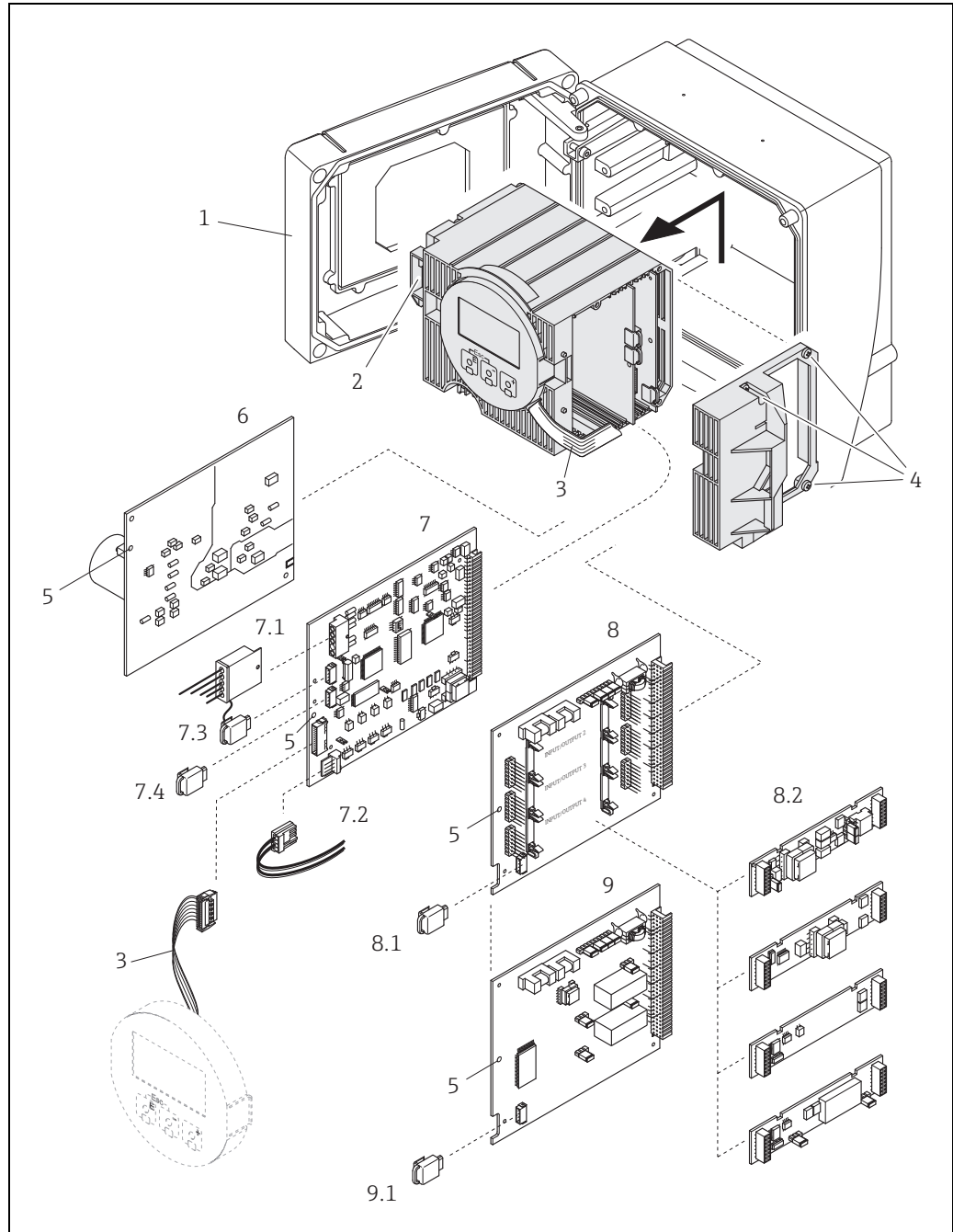

a0005520

Fig. 67: Wall-mounted housing: removing and installing printed circuit boards

- 1 Housing cover
- 2 Electronics module
- 3 Ribbon cable (display module)
- 4 Screws for electronics compartment cover
- 5 Aperture for installing /removing boards
- 6 Power unit board
- 7 Amplifier board
- 7.1 Electrode cable (sensor)
- 7.2 Coil current cable (sensor)
- 7.3 S-DAT (sensor data storage device)
- 7.4 T-DAT (transmitter data storage device)
- 8 I/O board (flexible assignment)
- 8.1 F-CHIP (function chip for optional software)
- 8.2 Pluggable submodules (inputs/outputs)
- 9 I/O boards (permanent assignment)
- 9.1 F-CHIP (function chip for optional software)

9.6.2 Replacing the device fuse



Warning!

Risk of electric shock. Exposed components carry dangerous voltages. Make sure that the power supply is switched off before you remove the cover of the electronics compartment.

The main fuse is on the power supply board → Fig. 61.

The procedure for replacing the fuse is as follows:

1. Switch off power supply.
2. Remove power unit board → 95.
3. Remove cap (1) and replace the device fuse (2).
Use only fuses of the following type:
 - 20 to 260 V AC / 20 to 64 V DC → 2.0 A slow-blow /250 V; 5.2 × 20 mm
 - Ex-rated devices → see the Ex documentation.
4. Installation is the reverse of the removal procedure.



Caution!

Use only original Endress+Hauser parts.

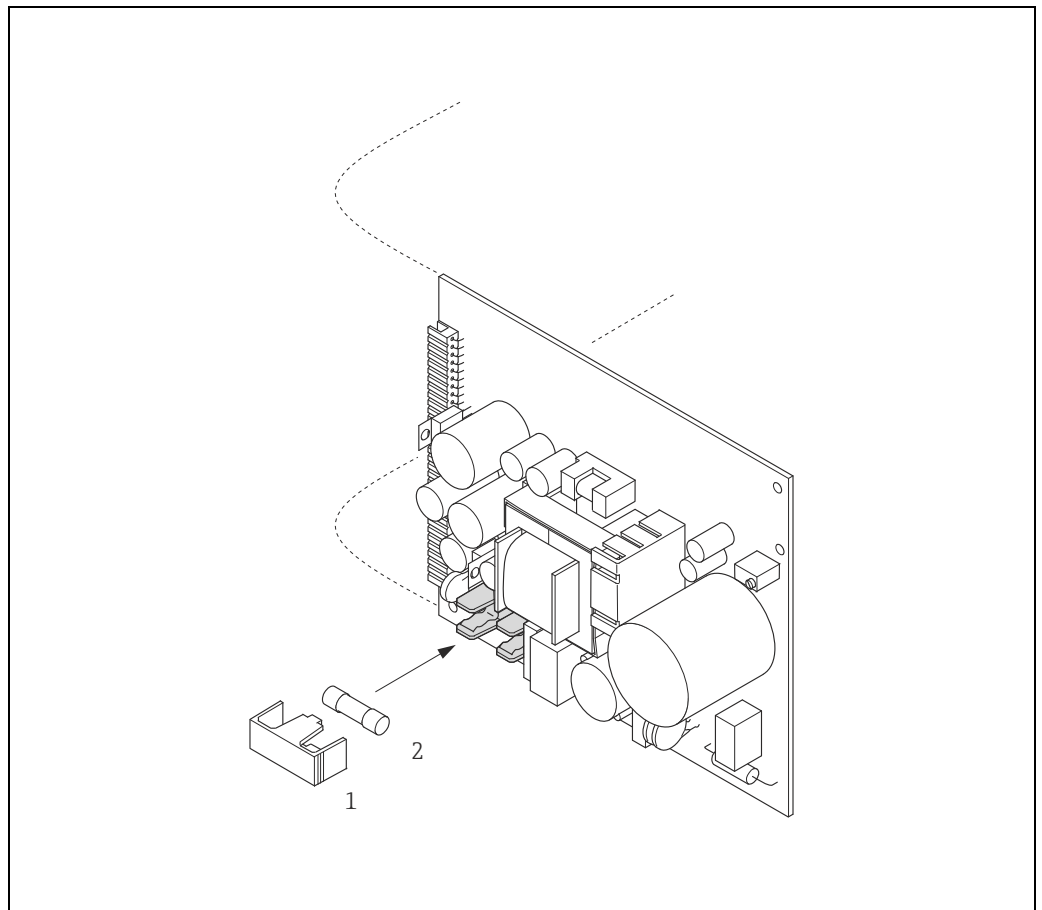

Fig. 68: Replacing the device fuse on the power supply board

- 1 Protection cap
2 Device fuse

9.7 Return

The measuring device must be returned if repairs or a factory calibration are required, or if the wrong measuring device has been ordered or delivered. According to legal regulations, Endress+Hauser, as an ISO-certified company, is required to follow certain procedures when handling returned products that are in contact with medium.

To ensure swift, safe and professional device returns, please read the return procedures and conditions on the Endress+Hauser website at www.services.endress.com/return-material

9.8 Disposal

Please observe the regulations applicable in your country or region.

9.9 Software history

Date	Software version	Changes to software	Documentation
06.2009	1.02.XX	Calibration history	71104962/10.09
11.2007	1.01.XX	New functionalities: Conductivity	71064033/11.07
09.2006	1.00.XX	Original software	71031145/09.06

10 Technical data

10.1 Application

→  4

10.2 Function and system design

Measuring principle Electromagnetic flow measurement on the basis of Faraday's Law.

Measuring system →  6

10.3 Input

Measured variable

- Flow rate (proportional to induced voltage)
- Conductivity (without temperature compensation)

Measuring range

- Flow rate: Typical $v = 0.01$ to 10 m/s (0.03 to 33 ft/s) with the specified measuring accuracy
- Conductivity $s = 5$ to 2000 $\mu\text{S}/\text{cm}$, not for sensors without reference electrode (Promag H, Promag S with brush electrodes)

Operable flow range Flow rate: Over 1000 : 1

Input signal

Status input (auxiliary input):
 $U = 3$ to 30 V DC, $R_i = 5$ k Ω , galvanically isolated
 Configurable for: totalizer(s) reset, positive zero return, error-message reset

Current input:

Active/passive selectable, galvanically isolated, full scale value adjustable, resolution: 3 μA , temperature coefficient: typically 0.005 % o.f.s./ $^{\circ}\text{C}$; (0.003 % o.f.s./ $^{\circ}\text{F}$)

- Active: 4 to 20 mA, $R_i \geq 150$ Ω , $U_{\text{out}} = 24$ V DC, short-circuit proof
- Passive: $0/4$ to 20 mA, $R_i \leq 150$ Ω , $U_{\text{max}} = 30$ V DC

10.4 Output

Output signal

Current output:
 Active/passive selectable, galvanically isolated, time constant selectable (0.01 to 100 s), full scale value adjustable, temperature coefficient: typically 0.005 % o.f.s./ $^{\circ}\text{C}$ (0.003 % o.f.s./ $^{\circ}\text{F}$), resolution: 0.5 μA

- Active: $0/4$ to 20 mA, $R_L < 700$ Ω (for HART: $R_L \geq 250$ Ω)
- Passive: 4 to 20 mA; supply voltage V_S : 18 to 30 V DC; $R_i \geq 150$ Ω

Pulse / frequency output:

Active/passive selectable (Ex i version passive only), galvanically isolated

- Active: 24 V DC, 25 mA (max. 250 mA over 20 ms), $R_L > 100$ Ω
- Passive: open collector, 30 V DC, 250 mA

- Frequency output: end frequency 2 to 10000 Hz ($f_{\max} = 12\,500$ Hz), on/off ratio 1:1, pulse width max. 10 s
- Pulse output: pulse value and pulse polarity selectable, pulse width configurable (0.05 to 2000 ms)

Signal on alarm

Current output:
 Failsafe mode selectable (e.g. according to NAMUR recommendation NE 43)

Pulse / frequency output:
 Failsafe mode selectable

Relay output:
 "de-energized" in the event of a fault or power supply failure

Details →  92

Load

See "output signal"

Switching output

Relay output:
 Normally closed (NC or break) or normally open (NO or make) contacts available (default: relay 1 = NO, relay 2 = NC), max. 30 V / 0.5 A AC; 60 V / 0.1 A DC, galvanically isolated. Configurable for: error messages, empty pipe detection (EPD), direction of flow, limit values

Galvanic isolation

All circuits for inputs, outputs, and power supply are galvanically isolated from each other.

Low flow cutoff

Switch points for low flow cut off freely selectable.

10.5 Power supply

Terminal assignment

→  33

Supply voltage

- 20 to 260 V AC, 45 to 65 Hz
- 20 to 64 V DC

Power consumption

Power consumption

- AC: <45 VA at 260 V AC; <32 VA at 110 V AC (incl. sensor)
- DC: <19 W (including sensor)

Switch-on current

- Max. 2.5 A (< 200 ms) at 24 V DC
- Max. 2.5 A (<5 ms) at 110 V AC
- Max. 5.5 A (<5 ms) at 260 V AC

Power supply failure

Lasting min. 1 power cycle:

- EEPROM or HistoROM/T-DAT saves measuring system data if power supply fails
- HistoROM/S-DAT: exchangeable data storage device which stores sensor characteristic data (nominal diameter, serial number, calibration factor, zero point etc.)

Potential equalization

→  42

Cable entries

Power-supply and electrode cables (inputs/outputs):

- Cable gland M20 × 1.5 (8 to 12 mm / 0.31 to 0.47 inch)

- Cable gland sensor for armored cables M20 × 1.5 (9.5 to 16 mm / 0.37 to 0.63 inch)
- Cable entries for thread ½" NPT, G ½"

Connecting cable for remote version:

- Cable gland M20 × 1.5 (8 to 12 mm / 0.31 to 0.47 inch)
- Cable gland sensor for armored cables M20 × 1.5 (9.5 to 16 mm / 0.37 to 0.63 inch)
- Cable entries for thread ½" NPT, G ½"

Cable specification →  37

10.6 Performance characteristics

Reference operating conditions

- Error limits following DIN EN 29104, future ISO 20456
- Water, typically +15 to +45°C (+59 to +113 °F); 0.5 to 7 bar (73 to 101 psi)
- Specification as per calibration protocol
- Data on the measured error based on accredited calibration rigs traced back to ISO 17025

Maximum measured error Volume flow

Pulse output:

- Standard: ±0.2% o.r. ± 2 mm/s (o.r. = of reading)
- With option brush electrodes: ±0.5% o.r. ± 2 mm/s (o.r. = of reading)

Current output:

in addition typically ± 5 µA



Note!

Supply-voltage fluctuations have no effect within the specified range.

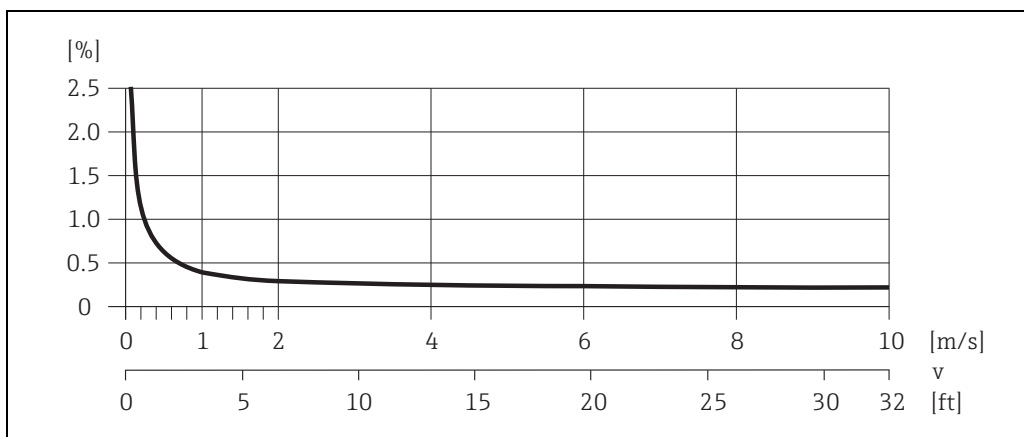

Fig. 69: Max. measured error in % of reading

Conductivity

- Max. measuring error not specified
- Without temperature compensation

Repeatability

Volume flow

- Standard: max. ±0.1% o.r. ± 0.5 mm/s (o.r. = of reading)
- With brush electrodes (Option): max. ±0.2% o.r. ± 0.5 mm/s (o.r. = of reading)

Conductivity

- Max. ±5% o.r. (o.r. = of reading)

10.7 Installation

Installation instructions →  12

Inlet and outlet runs
 Inlet run: typically $\geq 5 \times \text{DN}$
 Outlet run: typically $\geq 2 \times \text{DN}$

Length of connecting cable The permissible cable length L_{max} for the remote version depends on the conductivity of the medium →  19.

10.8 Environment

Ambient temperature range

Transmitter:

- Standard:
 - Compact version: -20 to $+50$ °C (-4 to $+122$ °F)
 - Remote version: -20 to $+60$ °C (-4 to $+140$ °F)
- Optional:
 - Compact version: -40 to $+50$ °C (-40 to $+122$ °F)
 - Remote version: -40 to $+60$ °C (-40 to $+140$ °F)



Note!
 At ambient temperatures below -20 °C (-4 °F), the readability of the display may be impaired.

Sensor:

- Flange material carbon steel: -10 to $+60$ °C ($+14$ to $+140$ °F)
- Flange material stainless steel: -40 to $+60$ °C (-40 to $+140$ °F)



Caution!
 Do not exceed the min. and max. temperatures for the lining of the measuring tube (→ "Medium temperature range").

Note the following points:

- Install the device at a shady location. Avoid direct sunlight, particularly in warm climatic regions.
- If both fluid and ambient temperatures are high, install the transmitter at a remote location from the sensor (→ "Medium temperature range").

Storage temperature The storage temperature corresponds to the operating temperature range of the transmitter and sensor.

Degree of protection

Transmitter

- As standard: IP 67, type 4X enclosure

Sensor

- As standard: IP 67, type 4X enclosure
- Optionally available for remote version for Promag S:
 - IP 68, type 6P enclosure

Shock and vibration resistance Acceleration up to 2 g by analogy with IEC 600 68-2-6
 (High temperature version: no data available)

Interior cleaning



Caution!
The maximum fluid temperature permitted for the measuring device must not be exceeded.

CIP cleaning possible:
Promag S (with PFA), Promag H

CIP cleaning not possible:
Promag S (with PU, PTFE, hard rubber, natural rubber)

SIP cleaning possible:
Promag S (with PFA), Promag H

SIP cleaning not possible:
Promag S (with PU, PTFE, hard rubber, natural rubber)

Electromagnetic compatibility (EMC)

According to IEC/EN 61326 and NAMUR recommendation NE 21

10.9 Process

Medium temperature range

The permitted temperature depends on the lining of the measuring tube:

Promag S

- 0 to +80 °C (+32 to +176 °F) for hard rubber (DN 65 to 600 / 2½ to 24")
- 0 to +60 °C (+32 to +140 °F) for natural rubber (DN 65 to 600 / 2½ to 24")
- -20 to +50 °C (-4 to +122 °F) for polyurethane (DN 25 to 600 / 1 to 40")
- -20 to +180 °C (-4 to +356 °F) for PFA (DN 25 to 200 / 1 to 8"), restrictions → see diagrams
- -40 to +130 °C (-40 to +266 °F) for PTFE (DN 15 to 600 / ½ to 24"), restrictions → see diagrams

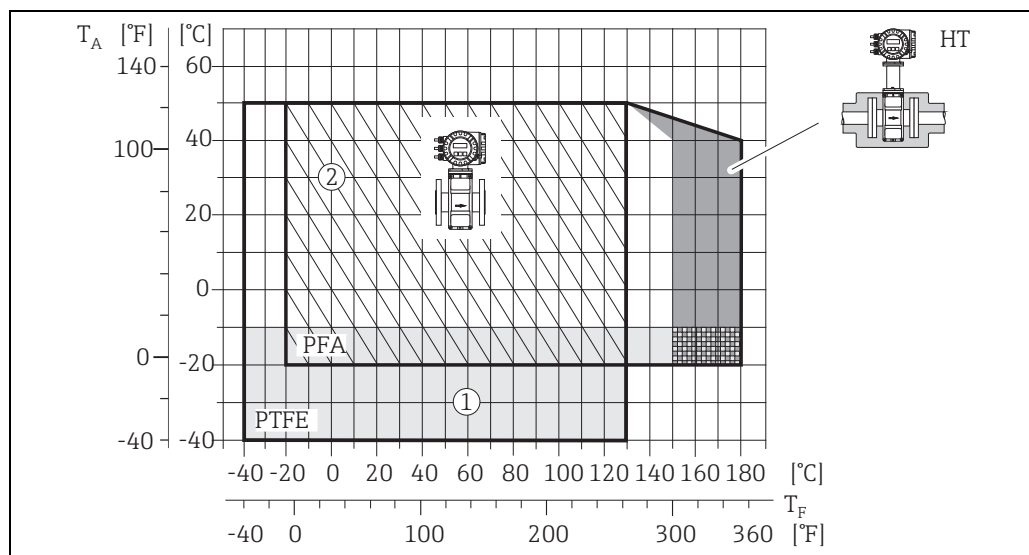

Fig. 70: Compact versions of Promag S (with PFA or PTFE lining)

T_A = ambient temperature; T_F = fluid temperature; HT = high-temperature version with insulation
 1 = Light gray area → Temperature range from -10 to 40 °C (-14 to -40 °F) applies only to stainless steel flanges
 2 = Diagonally hatched area → foam lining (HE) + degree of protection IP68 = fluid temperature max. 130°C

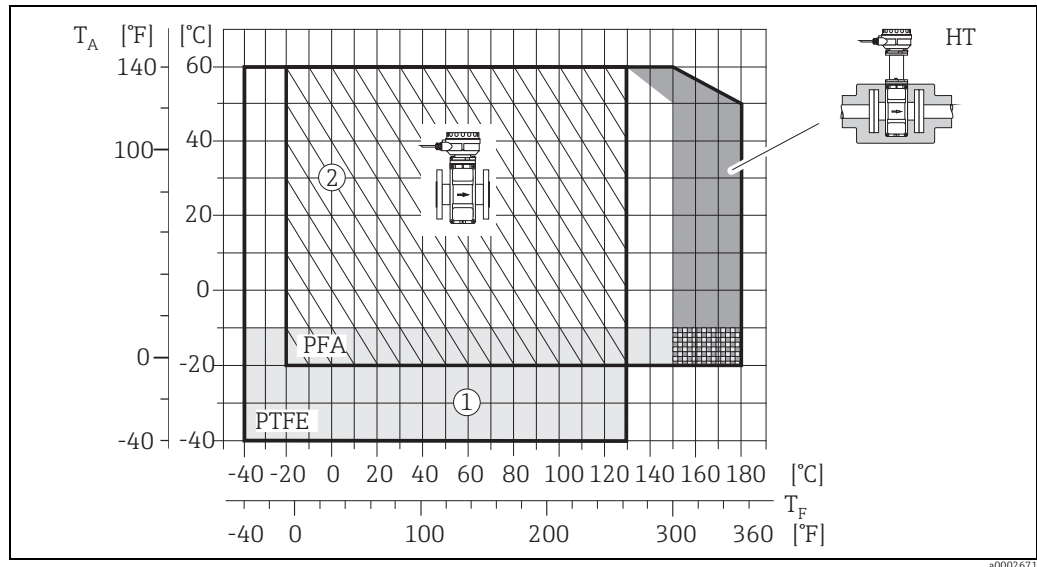

Fig. 71: Remote versions (with PFA or PTFE lining)

T_A = ambient temperature; T_F = fluid temperature; HT = high-temperature version with insulation

1 = Light gray area → Temperature range from -10 to 40 °C (-14 to -40 °F) applies only to stainless steel flanges
 2 = Diagonally hatched area → foam lining (HE) + degree of protection IP68 = fluid temperature max. 130°C

Promag H

Sensor:

- DN 2 to 25: -20 to +150 °C (-4 to +302 °F)
- DN 40 to 100: -20 to +150 °C (-4 to +302 °F)

Seals:

- EPDM: -20 to +150 °C (-4 to +302 °F)
- Silicone (VMQ): -20 to +150 °C (-4 to +302 °F)
- Viton (FKM): -20 to +150 °C (-4 to +302 °F)
- Kalrez: -20 to +150 °C (-4 to +302 °F)

Conductivity

The minimum conductivity is:
 ■ $\geq 5 \mu\text{S}/\text{cm}$ for fluids in general



Note!

In the remote version, the required minimum conductivity is also influenced by the length of the cable → 19.

Pressure-temperature ratings

An overview of the pressure-temperature ratings for the process connections are to be found in the "Technical Information" documents of the device in question.
 List of supplementary documentation → 115 section.

Limiting medium pressure range (nominal pressure)

Promag S

- EN 1092-1 (DIN 2501): PN 10 (DN 200 to 600/8 to 24"), PN 16 (DN 65 to 600/2½ to 24"), PN 25 (DN 200 to 600/8 to 24"), PN 40 (DN 15 to 150/½ to 6")
- ASME B16.5: Class 150 (DN ½ to 24"), Class 300 (DN ½ to 6")
- JIS B2220: 10 K (DN 50 to 600/2 to 24"), 20 K (DN 15 to 600/½ to 24")
- AS 2129: Table E (DN 25/1", DN 50/2")
- AS 4087: Cl. 14 (DN 50/2")

Promag H

The permissible nominal pressure depends on the process connection, the seal and the nominal diameter.

Details are provided in the separate documentation "Technical Information" → 115.

Pressure tightness
(lining)

Promag S (SI units)

Nominal diameter [mm]	Measuring tube lining	Resistance of measuring tube lining to partial vacuum (SI units) Limit values for abs. pressure [mbar] at various fluid temperatures						
		25 °C	50 °C	80 °C	100 °C	130 °C	150 °C	180 °C
25 to 600	Polyurethane	0	0	-	-	-	-	-
65 to 600	Natural rubber	0	0	-	-	-	-	-
65 to 600	Hard rubber	0	0	0	-	-	-	-

Nominal diameter [mm]	Measuring tube lining	Resistance of measuring tube lining to partial vacuum (SI units) Limit values for abs. pressure [mbar] at various fluid temperatures					
		25 °C	80 °C	100 °C	130 °C	150 °C	180 °C
15	PTFE	0	0	0	100	-	-
25	PTFE / PFA	0/0	0/0	0/0	100/0	-/0	-/0
32	PTFE / PFA	0/0	0/0	0/0	100/0	-/0	-/0
40	PTFE / PFA	0/0	0/0	0/0	100/0	-/0	-/0
50	PTFE / PFA	0/0	0/0	0/0	100/0	-/0	-/0
65	PTFE / PFA	0/0	*	40/0	130/0	-/0	-/0
80	PTFE / PFA	0/0	*	40/0	130/0	-/0	-/0
100	PTFE / PFA	0/0	*	135/0	170/0	-/0	-/0
125	PTFE / PFA	135/0	*	240/0	385/0	-/0	-/0
150	PTFE / PFA	135/0	*	240/0	385/0	-/0	-/0
200	PTFE / PFA	200/0	*	290/0	410/0	-/0	-/0
250	PTFE	330	*	400	530	-	-
300	PTFE	400	*	500	630	-	-
350	PTFE	470	*	600	730	-	-
400	PTFE	540	*	670	800	-	-
450	PTFE	Partial vacuum is impermissible					
500	PTFE						
600	PTFE						

* No value can be quoted.

Promag H

Nominal diameter [mm]	Measuring tube lining	Resistance of measuring tube lining to partial vacuum (SI units) Limit values for abs. pressure [mbar] at various fluid temperatures					
		25 °C	80 °C	100 °C	130 °C	150 °C	180 °C
2 to 150	PFA	0	0	0	0	0	0

Promag S (US units)

Nominal diameter [inch]	Measuring tube lining	Resistance of measuring tube lining to partial vacuum (US units) Limit values for abs. pressure [psi] at various fluid temperatures						
		77 °F	122 °F	176 °F	212 °F	266 °F	302 °F	356 °F
1 to 24"	Polyurethane	0	0	-	-	-	-	-
3 to 24"	Natural rubber	0	0	-	-	-	-	-
3 to 24"	Hard rubber	0	0	0	-	-	-	-

Nominal diameter [inch]	Measuring tube lining	Resistance of measuring tube lining to partial vacuum (US units) Limit values for abs. pressure [psi] at various fluid temperatures					
		77 °F	176 °F	212 °F	266 °F	302 °F	356 °F
½"	PTFE	0	0	0	1.5	-	-
1"	PTFE / PFA	0/0	0/0	0/0	1.5/0	-/0	-/0
1 ½"	PTFE / PFA	0/0	0/0	0/0	1.5/0	-/0	-/0
2"	PTFE / PFA	0/0	0/0	0/0	1.5/0	-/0	-/0
3"	PTFE / PFA	0/0	*	0.6/0	1.9/0	-/0	-/0
4"	PTFE / PFA	0/0	*	2.0/0	2.5/0	-/0	-/0
6"	PTFE / PFA	2.0/0	*	3.5/0	5.6/0	-/0	-/0
8"	PTFE / PFA	2.9/0	*	4.2/0	5.9/0	-/0	-/0
10"	PTFE	4.8	*	5.8	7.7	-	-
12"	PTFE	5.8	*	7.3	9.1	-	-
14"	PTFE	6.8	*	8.7	10.6	-	-
16"	PTFE	7.8	*	9.7	11.6	-	-
18"	PTFE	Partial vacuum is impermissible					
20"	PTFE						
24"	PTFE						

* No value can be quoted.

Promag H

Nominal diameter [inch]	Measuring tube lining	Resistance of measuring tube lining to partial vacuum (US units) Limit values for abs. pressure [psi] at various fluid temperatures					
		77 °F	176 °F	212 °F	266 °F	302 °F	356 °F
½ ₁₂ to 6"	PFA	0	0	0	0	0	0

Limiting flow

Further information can be found in the section "Nominal diameter and flow rate" → 17

Pressure loss

- No pressure loss if the sensor is installed in a pipe of the same nominal diameter.
- Pressure losses for configurations incorporating adapters according to DIN EN 545 → 16.

10.10 Mechanical construction

Design, dimensions

The dimensions and face-to-face length of the sensor and transmitter can be found in the separate "Technical Information" for each device which can be downloaded in PDF format from www.endress.com. A list of available "Technical Information" can be found in the section "Supplementary documentation" →  115.

Weight (SI units)



Promag S

Note!

The following weights apply to standard pressure ratings and without packaging material.

Nominal diameter [mm]	Weight in kilograms [kg]								
	Compact version			Remote version (without cable)					
	EN (DIN) / AS*	JIS	Sensor		Transmitter (Wall-mount housing)				
EN (DIN) / AS*			JIS						
15	PN 40	6.5	10K 10K	6.5	PN 40	4.5	10K	4.5	6.0
25		7.3		7.3		5.3		5.3	6.0
32		8.0		7.3		6.0		5.3	6.0
40		9.4		8.3		7.4		6.3	6.0
50		10.6		9.3		8.6		7.3	6.0
65	PN 16	12.0	10K 10K	11.1	PN 16	10.0	10K	9.1	6.0
80		14.0		12.5		12.0		10.5	6.0
100		16.0		14.7		14.0		12.7	6.0
125		21.5		21.0		19.5		19.0	6.0
150		25.5		24.5		23.5		22.5	6.0
200	PN 10	45	10K 10K	41.9	PN 10	43	10K	39.9	6.0
250		65		69.4		63		67.4	6.0
300		70		72.3		68		70.3	6.0
350		115		79		113		77	6.0
400		135		100		133		98	6.0
450		175		128		173		126	6.0
500		175		142		173		140	6.0
600		235		188		233		186	6.0

Transmitter (compact version): 3.4 kg
 High-temperature version: +1.5 kg
 * Only DN 25 and 50 are available for flanges according to AS

Promag H



Note!

The following weights apply to standard pressure ratings and without packaging material.

Nominal diameter DIN [mm]	Compact version (DIN)		Remote version (without cable; DIN)	
	Aluminum field housing	Stainless steel field housing	Sensor	Transmitter (wall-mount housing)
	[kg]	[kg]	[kg]	[kg]
2	5.2	5.7	2.0	6.0
4	5.2	5.7	2.0	6.0
8	5.3	5.8	2.0	6.0
15	5.4	5.9	1.9	6.0
25	5.5	6.0	2.8	6.0
40	7.1	7.6	4.1	6.0
50	7.6	8.1	4.6	6.0
65	8.4	8.9	5.4	6.0
80	9.0	9.5	6.0	6.0
100	10.3	10.8	7.3	6.0
125	15.7	16.2	12.7	6.0
150	18.1	18.6	15.1	6.0

Transmitter (compact version): 3.4 kg

Weight (US units)



Promag S

Note!

The following weights apply to standard pressure ratings and without packaging material.

Nominal diameter [inch]	Weight in pounds [lbs]				
	Compact version		Remote version (without cable)		
	ASME		Sensor ASME	Transmitter (Wall-mount housing)	
½"	Class 150	14	Class 150	10	13
1"		16		12	13
1 ½"		21		16	13
2"		23		19	13
3"		31		26	13
4"		35		31	13
6"		56		52	13
8"		99		95	13
10"		165		161	13
12"		243		238	13
14"		386		381	13
16"		452		448	13
18"		562		558	13
20"		628		624	13
24"		893		889	13

Transmitter (compact version): 7.5 lbs
High-temperature version: +3.3 lbs

Promag H

Note!

The following weights apply to standard pressure ratings and without packaging material.

Nominal diameter DIN [in]	Compact version (DIN)		Remote version (without cable; DIN)	
	Aluminum field housing	Stainless steel field housing	Sensor	Transmitter (wall-mount housing)
	[lbs]	[lbs]	[lbs]	[lbs]
1/12"	11.5	12.6	4.0	13.0
1/8"	11.5	12.6	4.0	13.0
3/8"	11.7	12.8	4.0	13.0
1/2"	11.9	13.0	4.0	13.0
1"	12.1	13.2	6.0	13.0
1 1/2"	15.7	16.8	4.1	13.0
2"	16.8	17.9	4.6	13.0
3"	19.8	20.9	6.0	13.0
4"	22.7	23.8	7.3	13.0
6"	39.9	41.0	15.1	13.0
Transmitter (compact version): 7.5 lbs				

Materials**Promag S**

Transmitter housing:

- Compact and remote version: Powder-coated die-cast aluminum
- Window material: glass or polycarbonate

Sensor housing:

- DN 15 to 300 (1/2 to 12"): powder-coated die-cast aluminum
- DN 350 to 600 (14 to 24"): painted steel

Measuring tube:

- DN < 350 (14"): stainless steel 1.4301 or 1.4306 (304L). For flanges made of carbon steel with Al/Zn protective coating.
- DN > 300 (12"): stainless steel 1.4301 (304). For flanges made of carbon steel with protective varnish.

Flanges:

- EN 1092-1 (DIN 2501): EN 1092-1 (DIN 2501): S235JRG2, S2345JR+N, P250GH, P245GH, A105, E250C, 1.4571, F316L (DN < 350/14": with Al/Zn protective coating; DN > 300/12" with protective varnish)
- ASME B16.5: A105, F316L (DN < 350/14" with Al/Zn protective coating; DN > 300/12" with protective varnish))
- JIS B2220: A105, A350 LF2, F316L (DN < 350/14" with Al/Zn protective coating; DN > 300/12" with protective varnish))
- AS 2129: A105, P235GH, P265GH, S235JRG2, E250C, with Al/Zn protective coating
- AS 4087: A105, P265GH, S275JR, E250C, with Al/Zn protective coating

Ground disks: 1.4435 (316L) or Alloy C-22

Electrodes:

- 1.4435, platinum, Alloy C-22, tantalum, titanium Gr. 2, tungsten carbide coating (for electrodes made of 1.4435)
- 1.4310/302 (for brush electrodes), Duplex 1.4462, Alloy X750 (for brush electrodes)

Seals: according to DIN EN 1514-1 form IBC

Promag H

Transmitter housing:

- Compact housing: Powder-coated die-cast aluminum or stainless steel field housing (1.4301 (316L))
- Wall-mount housing: Powder-coated die-cast aluminum
- Window material: glass or polycarbonate
- Sensor housing: stainless steel 1.4301
- Wall mounting kit (holder panel): stainless steel 1.4301
- Measuring tube: stainless steel 1.4301

Lining material:

- PFA (USP Class VI; FDA 21 CFR 177.1550; 3A)

Flanges:

- Connection generally made of stainless steel 1.4404, F316L
- Flanges (EN (DIN), ASME B16.5, JIS) also in PVDF
- Adhesive fitting made of PVC

Electrodes:

- Standard: 1.4435
- Optional: Alloy C-22, tantalum, platinum (only up to DN 25 (1"))

Seals:

- DN 2 to 25 ($\frac{1}{12}$ to 1"): O-ring (EPDM, Viton, Kalrez) or molded seal (EPDM*, silicone*, Viton)
 - DN 40 to 150 ($1\frac{1}{2}$ to 6"): molded seal (EPDM*, silicone*)
- * = USP class VI; FDA 21 CFR 177.2600: 3A

Grounding rings:

- Standard: 1.4435 (316L)
- Optional: Alloy C-22, tantalum

Fitted electrodes

Promag S

Available as standard:

- 2 measuring electrodes for signal detection
- 1 EPD electrode for empty pipe detection
- 1 Reference electrode for potential equalization

Optionally available for measuring electrodes made of platinum:

- 1 EPD electrode for empty pipe detection
- 1 reference electrode for potential equalization

For measuring tube with natural rubber lining in combination with brush electrodes:

- 2 brush electrodes for signal detection

Promag H

- 2 measuring electrodes for signal detection
- 1 EPD electrode for empty pipe detection, not for DN 2 to 8 ($\frac{1}{12}$ to $\frac{5}{16}$ ")

Process connections

Promag S

Flange connection:

- EN 1092-1 (DIN 2501)
 - DN < 300 (12"): form A
 - DN > 300 (12"): form B
 - DN 65 ($2\frac{1}{2}$ ") PN 16 and DN 600 (24") PN 16 exclusively according to EN 1092-1
- ASME
- JIS B2220
- AS 2129
- AS 4087

Promag H

With O-ring:

- Weld nipple DIN (EN), ISO 1127, ODT/SMS
- Flange EN (DIN), ASME, JIS
- Flange made of PVDF EN (DIN), ASME, JIS
- External thread
- Internal thread
- Hose connection
- PVC adhesive fitting

With molded seal:

- Weld nipple EN 10357 (DIN 11850), ODT/SMS
- Clamp ISO 2852, DIN 32676, L14 AM7
- Coupling DIN 11851, DIN 11864-1, ISO 2853, SMS 1145
- Flange DIN 11864-2

Surface roughness

All data relate to parts in contact with fluid.

- Liner → PFA: ≤ 0.4 μm (15 μin)
- Electrodes: 0.3 to 0.5 μm (12 to 20 μin)
- Process connection made of stainless-steel (Promag H):
 - With O-ring seal: ≤ 1.6 μm (63 μin)
 - With aseptic gasket seal: ≤ 0.8 μm (31.5 μin)
 - Optional: ≤ 0.38 μm (15 μin)

10.11 Operability**Display elements**

- Liquid-crystal display: illuminated, four lines with 16 characters per line
- Custom configurations for presenting different measured values and status variables
- 3 totalizers
- At ambient temperatures below -20 °C (-4 °F), the readability of the display may be impaired.

Operating elements

- Onsite operation with three optical sensor keys (S/O/F)
- Application-specific Quick Setup menus for straightforward commissioning

Language packages

Language groups available for operation in different countries:

- Western Europe and America (WEA):
English, German, Spanish, Italian, French, Dutch, Portuguese
- Eastern Europe/Scandinavia (EES):
English, Russian, Polish, Norwegian, Finnish, Swedish, Czech
- South and East Asia (SEA):
English, Japanese, Indonesian
- China (CN):
English, Chinese



Note!

You can change the language group via the operating program "FieldCare."

Remote operation

Operation by means of HART protocol

10.12 Certificates and approvals

CE approval	The measuring system described in these Operating Instructions therefore complies with the legal requirements of the EU Directives. Endress+Hauser confirms this by affixing the CE mark to it and by issuing the CE declaration of conformity.
C-tick symbol	The measuring system meets the EMC requirements of the "Australian Communications and Media Authority (ACMA)".
Ex approval	Information on the currently available Ex-rated versions (ATEX, FM, CSA, etc.) is available on request from your Endress+Hauser sales outlet. All information relevant to explosion protection is available in separate documents that you can order as necessary.
Sanitary compatibility	<p>Promag S</p> <p>No applicable approvals or certification</p> <p>Promag H</p> <ul style="list-style-type: none"> ■ 3A authorization and EHEDG-certified ■ Seals in conformity with FDA (except Kalrez seals)
Pressure equipment directive	<p>The devices can be ordered with or without a PED approval. If a device with a PED approval is required, this must be explicitly stated in the order. For devices with nominal diameters less than or equal to DN 25 (1"), this is neither possible nor necessary.</p> <ul style="list-style-type: none"> ■ With the PED/G1/x (x = category) marking on the sensor nameplate, Endress+Hauser confirms compliance with the "Essential Safety Requirements" specified in Annex I of the Pressure Equipment Directive 2014/68/EU. ■ Devices bearing this marking (PED) are suitable for the following types of medium: Media in Group 1 and 2 with a vapor pressure greater than, or smaller and equal to 0.5 bar (7.3 psi) ■ Devices not bearing this marking (PED) are designed and manufactured according to good engineering practice. They meet the requirements of Art.4 Section 3 of the Pressure Equipment Directive 2014/68/EU. The range of application is indicated in tables 6 to 9 in Annex II of the Pressure Equipment Directive 2014/68/EU.
Other standards and guidelines	<ul style="list-style-type: none"> ■ EN 60529 Degrees of protection by housing (IP code) ■ EN 61010-1 Protection Measures for Electrical Equipment for Measurement, Control, Regulation and Laboratory Procedures ■ IEC/EN 61326 "Emission in accordance with requirements for class A". Electromagnetic compatibility (EMC requirements). ■ ANSI/ISA-S82.01 Safety Standard for Electrical and Electronic Test, Measuring, Controlling and related Equipment - General Requirements. Pollution degree 2, Installation Category II. ■ CAN/CSA-C22.2 (No. 1010.1-92) Safety requirements for Electrical Equipment for Measurement and Control and Laboratory Use. Pollution degree 2, Installation Category I. ■ NAMUR NE 21 Electromagnetic compatibility (EMC) of industrial process and laboratory control equipment. ■ NAMUR NE 43

Standardization of the signal level for the breakdown information of digital transmitters with analog output signal.

- NAMUR NE 53
Software of field devices and signal-processing devices with digital electronics.

10.13 Ordering information

Detailed ordering information is available from the following sources:

- In the Product Configurator on the Endress+Hauser website: www.endress.com → Select country → Instruments → Select device → Product page function: Configure this product
- From your Endress+Hauser Sales Center: www.endress.com/worldwide



Note!

Product Configurator - the tool for individual product configuration

- Up-to-the-minute configuration data
- Depending on the device: Direct input of measuring point-specific information such as measuring range or operating language
- Automatic verification of exclusion criteria
- Automatic creation of the order code and its breakdown in PDF or Excel output format
- Ability to order directly in the Endress+Hauser Online Shop

10.14 Accessories

Various accessories are available for the transmitter and the sensor. These can be ordered separately from Endress+Hauser →  82.



Note!

For detailed information on specific order codes, please contact the Endress+Hauser service organization.

10.15 Documentation

- Flow Measurement (FA00005D/06)
- Promag 55S Technical Information (TI00071D/06)
- Promag 55H Technical Information (TI00096D/06)
- Promag 55 Description of Device Functions (BA00120D/06)
- Supplementary documentation on Ex-ratings: ATEX, FM, CSA, etc.

Index

A

Accessories	82
Adapters (installation of sensors)	16
Ambient temperature	104
Applicator (selection and configuration software)	83
Approvals	9
Auxiliary input	
See Status input	

B

Boards	
See Printed circuit boards	

C

Cable entries	
Degree of protection	44
Technical data	102
Cable length (remote version)	19
Cable specifications (remote version)	
Cable length, conductivity	19
Cable specifications	37
Calibration factor	7
CE mark (declaration of conformity)	9
Certificates	9
Change parameter / enter numerical values	49
Cleaning (exterior cleaning)	81
Code entry (function matrix)	50
Commissioning	
"Commissioning" Quick Setup menu	66
"Pulsating flow" Quick Setup menu	67
Configuring current input (active/passive)	73
Configuring current outputs (active/passive)	71
Configuring relay contacts (NC/NO)	74
Commubox FXA 195 (electrical connection)	41, 83
Communication	52
Conductivity of the fluid	
Length of connecting cable (remote version)	19
Connection	
See Electrical connection	
Control	
Device description files	53
Display and operating elements	
Field Xpert HART Communicator	53
FieldCare	53
Function matrix	49
C-tick mark	9
Current input	
Active/passive configuration	73
Electrical connection	40
Technical data	101
Current output	
Active/passive configuration	71
Electrical connection	40

D

Data back-up (of device data with T-DAT)	70
Declaration of conformity (CE mark)	9

Degree of protection	44
Designated use	4
Device description files	53
Device designation	6
Device functions	
See the "Description of Device Functions" manual	
Display	
Display and operating elements	
Local display	46
See Display	
Turning the display	29
Disposal	100
Documentation, supplementary	115
Down pipes	13
Druckgerätezulassung	114

E

Electrical connection	
Cable specification / length (remote version)	37
Commubox FXA 191	41
Degree of protection	44
HART handheld terminal	41
Post-connection check (checklist)	45
Potential equalization	42
Remote version (connecting cable)	33
Terminal assignment, transmitter	40
Transmitter	38
Electrode cleaning circuitry	
See the "Description of Device Functions" manual	14
Electrodes	
Electrode Cleaning Circuitry (ECC)	14
EPD electrode	14
Fitted electrodes	112
Measuring electrode plane	14
Reference electrode (potential equalization)	14
Test pulses (build-up detection)	77
Electromagnetic compatibility (EMC)	37
Electronics boards	
See Printed circuit boards	
Empty pipe detection (EPD)	
Empty pipe adjustment	79
EPD electrode	14
Environment	104
Error limits	
See Performance characteristics	
Error messages	
Confirming error messages	51
Process errors (application errors)	90
System errors (device errors)	86
Error types (system and process errors)	51
Europäische Druckgeräterichtlinie	114
Ex certification	114
Ex documentation	5
Exchange	
Device fuse	99
Printed circuit boards, removing and installing	95

Exterior cleaning	81	Installing sensor	
F		Adapters	16
Failsafe mode inputs/outputs	92	Foundations (DN > 300)	16
F-CHIP	80	High temperature version	25
Field Xpert SFX100	41	Promag H	26
FieldCare	53	Promag H with weld nipples	28
FieldCheck (tester and simulator)	83	Promag S sensor	20
Flow rate (as a function of nominal diameter)	17	Insulation of pipes (installing Promag S)	25
Fluid conductivity		L	
Length of connecting cable (remote version)	19	Language groups	113
Fluid pressure range	106	Length of connecting cable (remote version)	104
Fluid temperature ranges	105	Load (output signal)	102
Frequency output		Local display	
Electrical connection	40	See Display	
Technical data	101	Low flow cutoff	102
Full-pipe adjustment (EPD)	79	M	
Function check	64	Maintenance	81
Function descriptions		Materials	111
See the "Description of Device Functions" manual		Measured variable	101
Function matrix (operation)	49	Measuring accuracy	
Fuse, replacing	99	Maximum measured error	103
FXA193	83	Measuring electrodes	
FXA195	83	See Electrodes	
G		Measuring principle	101
Galvanic isolation	102	Measuring system	6
H		Measuring tube	
HART		Lining, resistance to partial vacuum	107
Command groups	52	Lining, temperature range	105
Command No.	55	N	
Error messages	55	Nameplate	
Field Xpert HART Communicator	53	Connections	8
Write protection, switching on and off	63	Sensor	7
High temperature version		Transmitter	6
Installation	25	Nominal pressure	
Temperature ranges	25	See Fluid pressure range	
HOME position (operating mode)	46	O	
I		Operable flow range	101
Incoming acceptance	10	Operating conditions	104
Inlet runs	15	Operational safety	5
Input signal	101	Order code	
Input variables	101	Accessories	82
Installation		Sensor	7
Sensor		Transmitter	6
See Installing sensor		Outlet runs	15
Wall-mount housing	30	Output	101
Installation conditions		Output signal	101
Dimensions	28	P	
Down pipes	13	Post-installation check (checklist)	32
Foundations, supports	16	Power consumption	102
Inlet and outlet runs	15	Power supply (supply voltage)	102
Installing pumps	12	Power supply failure	102
Location	12	Pressure loss	
Nominal diameter and flow rate	17	Adapters (reducers, expanders)	16
Orientation (vertical, horizontal)	14	General information	108
Partially filled pipes	12	Resistance of measuring tube lining to partial vacuum	
Vibrations	15		

107	
Pressure-temperature ratings	106
Printed circuit boards, removing and installing	
Field housing	95
Wall-mount housing	97
Process connections	112
Process error	
Definition	51
Process error messages	90
Process errors without message	90
Programming mode	
Disable	51
Enable	50
Pulsating flow	67
Pulse output	
See Frequency output	
Pumps	
Location	12
Pump types, pulsating flow	67
Q	
Quick Setup	
Commissioning	66
Data back-up (of device data with T-DAT)	70
Pulsating flow	67
R	
Registered trademarks	9
Relay output	
Configure relay contact (NC/NO)	74
Electrical connection	40
Technical data	102
Resistance of measuring tube lining to partial vacuum	107
S	
Safety icons	5
Safety instructions	5
Sanitary compatibility	114
Screw tightening torques	
for Promag H (with plastic process connections)	26
S-DAT (HistoROM)	80
Seals	81
Promag H	26
Seals (sensor process connection)	20
Sensor installation	
See Installing sensor	
Serial number	6–8
Service interface	
Commubox FXA291	83
Shock resistance	104
Signal on alarm	102
Software	
Amplifier display	64
Versions (History)	100
Spare parts	94
Standards, guidelines	114
Status input	
Electrical connection	40
Technical data	101
Storage	11
Supplementary Ex documentation	5
Supply voltage (power supply)	102
Switching output	
See Relay output	
System error	
Definition	51
System error messages	86
T	
T-DAT (HistoROM)	
Description	80
Save/load (data back-up, e.g. for replacing devices)	70
Temperature range	
Medium temperature range	105
Temperature ranges	
Ambient temperature	104
Storage temperature	104
Torque (installing Promag S)	21
Transmitter	
Electrical connection	38
Installing the wall-mount housing	30
Length of connecting cable (remote version)	19
Turning the field housing	28
Transporting the sensor	10
Trouble-shooting	
Instructions, procedure	85
Removing and installing electronics boards	95
V	
Vibration resistance	104
Vibrations	15
Measures to prevent vibrations	15
Shock and vibration resistance	104
W	
Wall-mount housing, installing	30
Weights	109–110
Welding work	
Grounding welding equipment	28
Promag H with weld nipples	28
Wiring	
See Electrical connection	
Write protection (HART on/off)	63

www.addresses.endress.com
