



Level



Pressure



Flow



Temperature



Liquid
Analysis



Registration



Systems
Components



Services



Solutions

Technical Information

Fieldgate Input Module FXZ520

Analog and digital inputs
as extensions to Fieldgate FXA520



Application

Fieldgate Input Modules FXZ520 are used together with Fieldgate FXA520 for remote scanning of conventional 4...20 mA measuring instruments, binary switches and pulse transmitters.

Each Fieldgate Input Module FXZ520 has four galvanically isolated channels of the same type. Up to seven FXZ520s can be operated with a Fieldgate FXA520. Together with the two integrated analog inputs of the Fieldgate itself, up to 30 conventional measuring points can be connected.

Alternatively, Input Module FXZ520 can be used with Fieldgate FXA520 in mixed operation with a HART multiplexer. This allows remote scanning of both legacy and newer HART devices in the installed base.

Features and Benefits

- Integration of conventional inputs in remote scanning of the installed base
- Modular extension of Fieldgate FXA520 with 4 to 28 additional channels
- Individual galvanic isolation of all channels
- Voltage drop per channel ≤ 6 V
- Configuration via web pages of Fieldgate FXA520
- Scaling and linearization of analog inputs
- Optional totalizing of digital input signals
- Mixed operation with HART multiplexer possible

Function and System Design

Function

Fieldgate Input Module FXZ520 connects conventional measuring instruments, switches and pulse transmitters to a Fieldgate FXA520. Up to seven input modules can be connected to one Fieldgate via the RS-485 interface, allowing up to 30 measured values to be displayed in the Fieldgate Web server.

Fieldgate Input Module FXZ520 is available in two versions:

- Analog: for the connection of up to four 4...20 mA devices
- Digital: for the connection of up to four binary switches or pulse transmitters.

Analog input signals can be scaled and linearized in the Fieldgate Web server. In addition, warning and alarm limits can be assigned. Binary signals can be configured as switching signals or as up- and down-count totalizers.

System design

Fig. 1 shows a typical system architecture. Up to four analog or digital devices with separate power supplies are connected to one Fieldgate Input Module FXZ520 each of the appropriate type.

Depending upon the type of Fieldgate FXA520, the Fieldgate Web server publishes the conditioned signals to an Internet browser or Fieldgate Viewer via Ethernet, telephone or GSM. In this manner, the measured values and switching status can be observed from anywhere in the world.

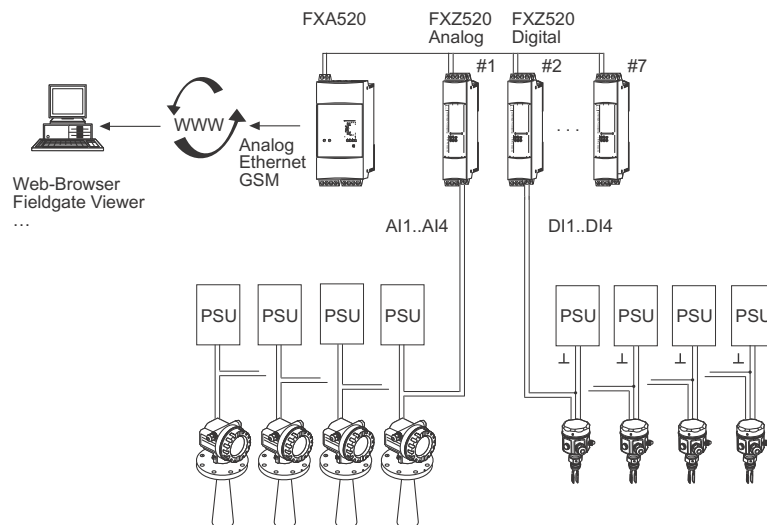

Fig. 1: Example of system architecture

A total of seven Input Modules can be connected to the Fieldgate via the RS-485 interface. The RS-485 addresses are set via DIP switch. A terminating resistor is integrated in the Fieldgate FXA520. The second terminating resistor is not required when the Fieldgate and Input Modules are mounted in a cabinet.

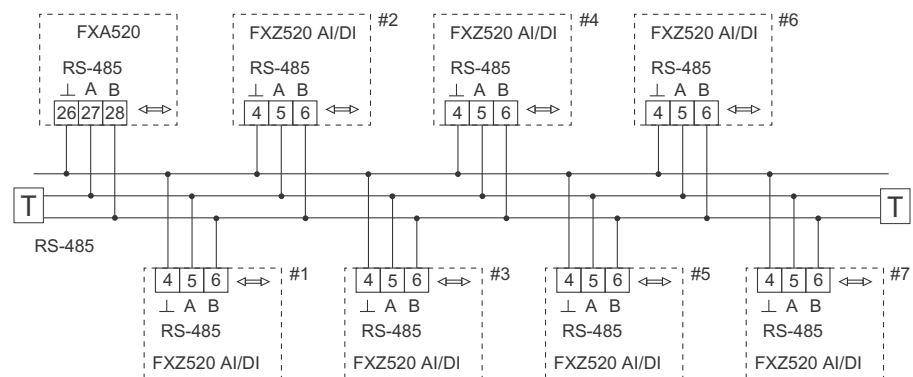

Fig. 2: Example of RS-485 bus architecture

Input

FXZ520 Analog

No. of analog inputs	4
Input signal	4...20 mA, active
Max. input current per channel	70 mA
Accuracy	better than 0.5%
Voltage drop (incl. protective diode)	≤6.0 V
Galvanic isolation	Mutual isolation between channels and internal circuits
Connecting cable	Installation cable, unshielded
Line resistance	Max. 25 Ω per core

FXZ520 Digital

No. of digital inputs	4
Input signal	Voltage signal, 0 V to 30 V
Switching thresholds	Low signal: -3 V to +5 V High signal: +15 V to +30 V
Input current for High signal	5 mA
Max. quiescent current for Low signal	1 mA
Event counter measuring range	0 kHz to 12.5 kHz
Galvanic isolation	Mutual isolation between channels and internal circuits
Connecting cable	Installation cable, inshielded
Line resistance	Max. 25 Ω per core

Output

RS-485 interface

Baudrate	9600 Byte/s
Module addresses	Via DIP switch, 1 to 7
Channel addresses	Dependent upon module address: Module address 1: 4, 5, 6, 7; module address 7: 28, 29, 30, 31
Internal resistance	68 kΩ
Galvanic isolation	500 V rms
Connecting cable	Shielded, twisted pairs (STP)
Termination A-B	For long cable runs, both ends 120 Ω <ul style="list-style-type: none"> ■ A terminating resistor is built into the Fieldgate FXA720 ■ For cabinet mounting, the second terminating resistor is not required
Max. cable length	1200 m

Power Supply

Power

	Alternating voltage version	Direct voltage version
Voltage range	85 VAC to 253 VAC, 50/60 Hz	20...60 VDC or 20...30 VAC
Galvanic isolation	Safe isolation between power supply and internal circuits	
Power consumption	<4 VA at 253 VAC	<1 W at 20 VDC

Operating Conditions

Mechanical	Installation	Control cabinet or protective enclosure: The devices are to be mounted such that they are protected from the weather, mechanical damage, and if possible direct sunlight. This especially important in warm countries. For protective enclosures max. 1x FXA520 + 2x FXZ520 are allowed
	Mechanical conditions	Class 3M2 as per EN 60721-3-3

Cabinet mounting

For cabinet mounting, the minimum clearances must be observed

- between assemblies with Ex and non-Ex power supplies
- between Ex assemblies with separate power supplies

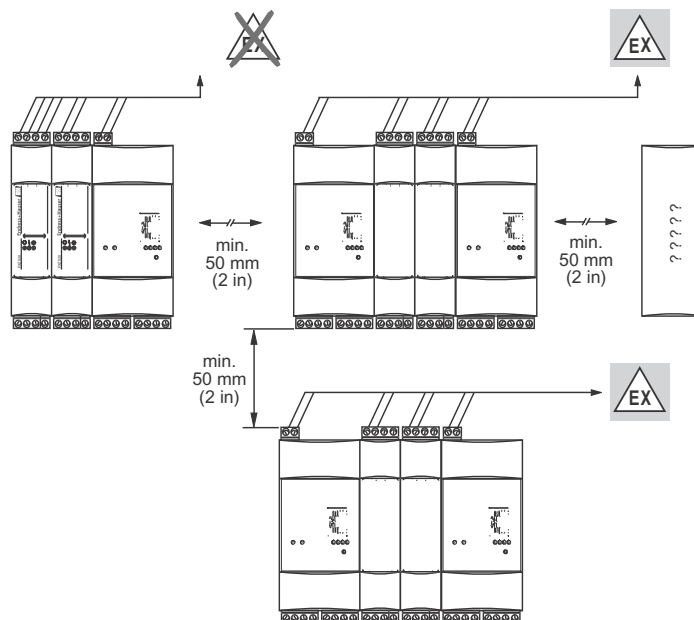

Environment	Ambient temperature Operation:	With natural convection: Single mounting: -20°C to $+60^{\circ}\text{C}$ (-4°F to $+140^{\circ}\text{F}$) Row mounting without lateral spacing: -20°C to $+50^{\circ}\text{C}$ (-4°F to $+122^{\circ}\text{F}$) In protective enclosure, see installation: -20°C to $+40^{\circ}\text{C}$ (-4°F to $+104^{\circ}\text{F}$)
	Storage:	-25°C to $+85^{\circ}\text{C}$, preferably at $+20^{\circ}\text{C}$ (-13°F to $+185^{\circ}\text{F}$, preferably at $+68^{\circ}\text{F}$)
	Climatic conditions	Class 3K3 as per DIN EN 60721-3-3
	EMC Interference: Immunity:	Guideline 89/336/EWG as per EN 61326, Class B equipment as per EN 61326, Annex A (industrial locations) and NAMUR Recommendation NE21

Mechanical Construction

General	Housing	Rail-mounted
	Mounting	Top-hat rail to EN 60715; HT 35x7,5 or EN 60715; HT 35x15
	Degree of protection	IP 20 as per EN 60529
	Material	Housing: polycarbonate; color: light grey, RAL 7035 Front panel: polyamide PA6; color: blue Top-hat rail fastener: polyamide PA6; color: black RAL 9005
	Terminals	Type of terminal: pluggable, screw terminals Core cross-section: 1x 2.5 mm or 2x 1.5 mm (1x 10 AWG, 2x 15 AWG)
	Weight	110 g (4 oz)
	Dimensions	22.5 mm x 108 mm x 112 mm (0.9" x 4.25" x 4.4") Dimensional drawing, see below

Dimensional drawing

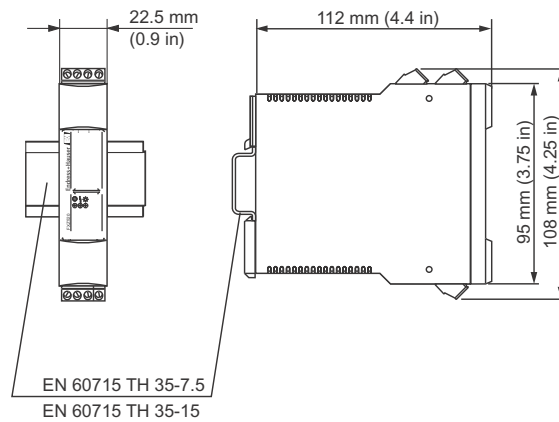

Terminal assignment

Position	No.	Function	Remarks
	1	L1 or L+	85 to 253 VAC 20 to 60 VDC or 20 to 30 VAC, 50/60 Hz
	2	L1 or L+	
	15	N or L-	85 to 253 VAC 20 to 60 VDC or 20 to 30 VAC, 50/60 Hz
	16	N or L-	
	4	GND	RS-485 communication interface
	5	A	RS-485 communication interface
	6	B	RS-485 communication interface
	7	Channel 1 -	Analog or digital signal 1
	8	Channel 1 +/S	Analog or digital signal 1
	9	Channel 2 -	Analog or digital signal 2
	10	Channel 2 +/S	Analog or digital signal 2
	11	Channel 3 -	Analog or digital signal 3
	12	Channel 3 +/S	Analog or digital signal 3
	13	Channel 4 -	Analog or digital signal 4
14	Channel 4 +/S	Analog or digital signal 4	

Operability

Display elements

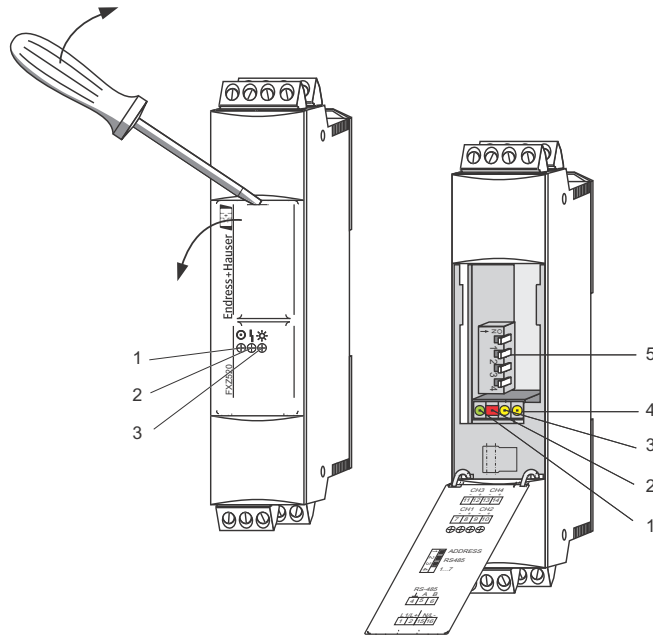

No.	Element	Significance
1	Green LED	Permanently lit: correct voltage supply present Blinks: communicating with Fieldgate FXA520
2	Red LED	Permanently lit: Fault
3	Yellow LED	Permanently lit: Normal operation
4	Yellow LED	Not used

Operating elements

No.	Element	Significance
5	DIP switch	Setting of the RS-485 address range
	Switch settings	
	Address range CH1 - CH4	4 - 7 8 - 11 12 - 15 16 - 19 20 - 23 24 - 27 28 - 31

Display in Fieldgate Web server

The input signals of the Fieldgate Input Module FXZ520 are displayed in the Overview page of the Fieldgate Web server. Measuring range, limit values etc. can be assigned using various menus.

Tag	Description	Actual Value 01.06.2006 13:06:06	Device status/Limit 01.06.2006 13:06:06	max. Value min. Value
BoardTemp	Endress+Hauser Internal	29.03 °C	OK	
CORLIUS	Endress+Hauser Promag 83	3534.08 kg/h	OK	3600.00 kg/h 3500.00 kg/h
CORLIUS	Endress+Hauser Promag 83	57506728.00 kg	OK	
FLOW MID	Endress+Hauser Promag 53	17.73 l/s	OK	
FLOW MID	Endress+Hauser Promag 53	6.9278157e+08 l	OK	
LEVEL	Level Tank 1 test Rothaus Pils	7.42 m	OK	10.00 m 0.00 m
PRESSURE	Luftdruck Brombach	988.44 mbar	OK	1020.00 mbar 940.00 mbar
PRESSURE	Cerabar Temperatur	19.41 °C	OK	50.00 °C -20.00 °C
TEMP OUT	Außentemperatur ungüllig	50.82 °C	OK	
TEMP OUT	Außentemperatur güllig	13.94 °C	OK	60.00 °C -20.00 °C

Configuration in Fieldgate Web server

Fieldgate FXA520 Version 1.04.xx or greater is required for the configuration of Fieldgate Input Module FXZ520. The input signals are configured in the Fieldgate Web server:

- **Switch to Administration Mode=>Settings=>Input**
- **FXZ520 Inputs=>Analog In-XY or Digital In-XX,**
 where X = Setting of address switch 1...7 and Y = channel number 1...4

Analog input setup

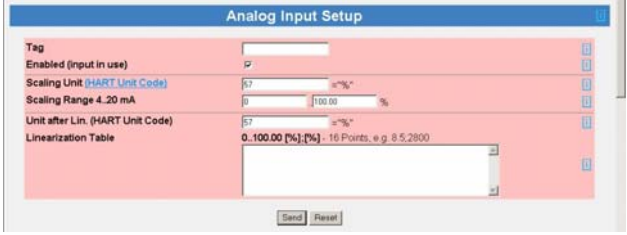
Parameter	Description
	
Tag	Enter the Device Tag that is to appear in the overview page
Enabled	Check this box if this input is to appear on the overview page
Scaling Unit	Enter the HART unit code for the scaling unit – HART Unit Code reveals a list of units and codes
Scaling Range	Enter the range end values in engineering units corresponding to the 4 mA and 20 mA signal
Units After Linearization	Enter the engineering units in plain text to be used after linearization
Linearization Table	Enter a linearization table with maximum 16 value pairs in the form x;y The linearized output value is shown as a secondary value for the device in the Overview page.
Send	Press to register your changes in the Fieldgate.
Reset	Press to discard any changes made since the previous send.

Digital input setup

Parameter	Description
	
Tag	Enter the Device Tag that is to appear in the overview page
Enabled	Check this box if this input is to appear on the overview page
Impulse Counter	Check this box if the input is to act as an impulse counter
Scaling Unit	Enter the HART unit code for the scaling unit – Press HART Unit Code to reveal a list of units and codes
Counts per Unit	Enter the number of counts that correspond to 1 scaling unit
Downcount	Check this box if the counter is to count downwards
Start Value	Enter the value in scaling units from which the downcount is started
Start Time	Read-only time stamp for start of count (with Send pressed)
Restart with Start Value on Send	Check this box then press Send to restart the counter – The count starts at 0 or the start value, depending upon configuration
Send	Press to register your changes in the Fieldgate.
Reset	Press to discard any changes made since the previous send.

Ordering Information

Product structure

FXZ520 Fieldgate Input Module	
	Certificate
A	without
F	CSA General Purpose, CSA C US
	Power Supply
A	85 to 253 VAC, 50/60 Hz
E	20 to 30 VAC, 20 to 60 VDC
	Input Signal
A	4x 4...20 mA
D	4x digital
FXZ520-	

Certificates and Approvals

Certificates

CE certificate	EN 60529: Degrees of protection provided by enclosures (IP Code) EN 61010: Safety requirements for electrical equipment for measurement, control, and laboratory use EN 61326: Electromagnetic compatibility
----------------	--

Documentation

Brochures

- SupplyCare Inventory Control
Field of Activity
FA003V/00/en
- Fieldgate Solutions
Innovation brochure
IN005F/00/en

Operating Instructions

- Fieldgate Input Module FXZ520
Compact Instructions
KA272F/00/a6
- Fieldgate FXA520
Operating Instructions
BA051S/04/en

International Headquarters

Endress+Hauser
GmbH+Co. KG
Instruments International
Colmarer Str. 6
79576 Weil am Rhein
Deutschland

Tel. +49 76 21 9 75 02
Fax +49 76 21 9 75 34 5
www.endress.com
info@ii.endress.com

Endress+Hauser 

People for Process Automation

