



Level



Pressure



Flow



Temperature

Liquid  
Analysis

Registration

Systems  
Components

Services



Solutions

## Technical Information

# Proline t-mass 65F, 65I

## Thermal Mass Flow Measuring System Direct Mass Flow Measurement of Gases



### Application

For measuring the mass flowrate of a wide range of gas types e.g.

- Compressed air
- Natural gas flow to boilers/dryers
- Carbon Dioxide flow in breweries
- Biogas and aeration air in waste water plants
- Gas production (e. g. Ar, N<sub>2</sub>, CO<sub>2</sub>, He, O<sub>2</sub>)
- Leakage detection

Approvals for hazardous area:

- ATEX, FM, CSA, IECEx, NEPSI

Connection to all common process control systems:

- HART, PROFIBUS DP/PA, FOUNDATION Fieldbus, MODBUS RS485

### Your benefits

Direct measurement of gas mass flow. Provides temperature as an output.

The Proline transmitter concept comprises:

- Modular device and operating concept resulting in a higher degree of efficiency
- Quick setup operating menus for ease of commissioning
- On board software freely allows the selection of up to 20 pure gases and creation of mixed gases with a maximum of 8 components (e. g. Biogas)

The t-mass sensors offer:

- Negligible pressure drop or loss
- Wide turndown of up to 100:1
- Insertion version can be programmed for circular pipe or rectangular ducting installation
- Each device individually calibrated and delivered with a traceable certificate
- Can be calibrated with flow conditioner on request.
- Optional hot tap device for insertion allowing ease of removal/replacement for range of process pressure up to 16 Barg (230 psig) and non-toxic gas applications.

## Table of contents

<b>Function and system design</b> .....	<b>3</b>	Process conditions for Hot tap .....	19
Measuring principle .....	3	<b>Mechanical construction</b> .....	<b>20</b>
Measuring system .....	3	Design, dimensions .....	20
<b>Input</b> .....	<b>4</b>	Weight .....	36
Measured variable .....	4	Materials .....	36
Measuring range (air at ambient conditions) .....	4	Material load curves .....	37
Input signal .....	5	Process connections .....	38
<b>Output</b> .....	<b>5</b>	<b>Human interface</b> .....	<b>39</b>
Output signal .....	5	Display elements .....	39
Signal on alarm .....	7	Operating elements .....	39
Load .....	7	Languages .....	39
Low flow cut off .....	7	Remote operation .....	39
Galvanic isolation .....	7	<b>Certificates and approvals</b> .....	<b>39</b>
Switching output .....	7	CE mark .....	39
<b>Power supply</b> .....	<b>8</b>	C-Tick mark .....	39
Electrical connection Measuring unit .....	8	Ex approval .....	39
Terminal assignment .....	9	FOUNDATION Fieldbus certification .....	39
Electrical connection Remote version .....	10	PROFIBUS DP/PA certification .....	40
Supply voltage .....	10	MODBUS certification .....	40
Cable entries .....	10	Pressure measuring device approval .....	40
Remote version .....		Oxygen service .....	40
cable specifications .....	10	Other standards and guidelines .....	40
Power consumption .....	10	<b>Ordering information</b> .....	<b>41</b>
Power supply failure .....	11	<b>Accessories</b> .....	<b>41</b>
Potential equalization .....	11	Device-specific accessories .....	41
<b>Performance characteristics</b> .....	<b>11</b>	Measuring principle-specific accessories .....	41
Calibration reference conditions .....	11	Service-specific accessories .....	42
Maximum measured error .....	11	Communication-specific accessories .....	42
Repeatability .....	11	<b>Documentation</b> .....	<b>43</b>
Influence of medium pressure .....		<b>Registered trademarks</b> .....	<b>43</b>
(Pressure co-efficient) .....	11		
Response time .....	11		
<b>Operating conditions: Installation</b> .....	<b>12</b>		
Installation instructions .....	12		
Inlet and outlet runs .....	14		
Mounting conditions for the insertion version .....	17		
Length of connecting cable .....	18		
<b>Operating conditions: Environment</b> .....	<b>18</b>		
Ambient temperature .....	18		
Storage temperature .....	18		
Degree of protection .....	18		
Shock resistance .....	18		
Vibration resistance .....	18		
Electromagnetic compatibility (EMC) .....	18		
<b>Operating conditions: Process</b> .....	<b>19</b>		
Medium temperature range .....	19		
Pressure loss .....	19		
Medium pressure range (nominal pressure) .....	19		
Flow limit .....	19		

## Function and system design

### Measuring principle

Thermal dispersion principle

The thermal principle operates by monitoring the cooling effect of a gas stream as it passes over a heated transducer (PT100).

Gas flowing through the sensing section passes over two PT 100 RTD transducers one of which is used conventionally as a temperature sensing device, whilst the other is used as a heater. The temperature sensor monitors the actual process values whilst the heater is maintained at a constant differential temperature above this by varying the power consumed by the sensor. The greater the mass flow, the greater the cooling effect and power required to maintain the differential temperature. The measured heater power is therefore a measure of the gas mass flowrate.

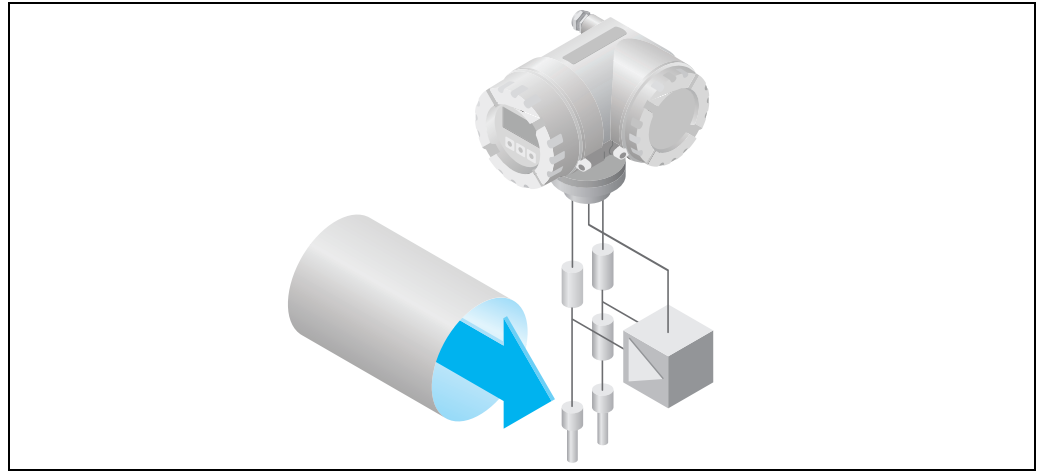

a0005136

### Measuring system

The measuring system consists of a transmitter and a sensor. Two versions are available:

- Compact version: transmitter and sensor form a single mechanical unit.
- Remote version: transmitter and sensor are mounted physically separate from one another.

Transmitter	
<p><b>t-mass 65</b></p> <p>a0003671</p>	<ul style="list-style-type: none"> <li>■ Two-line liquid-crystal display</li> <li>■ Configuration using push button operation</li> </ul>
Sensor	
<p><b>F</b></p> <p>a0005137</p>	<ul style="list-style-type: none"> <li>■ Flanged version</li> <li>■ Nominal diameters DN 15 to 100 (½" to 4")</li> <li>■ Sensor body material:                             <ul style="list-style-type: none"> <li>- 1.4404, 316L</li> <li>- CF3M</li> </ul> </li> <li>■ Transducer body material:                             <ul style="list-style-type: none"> <li>- 1.4404, 316L, Alloy C22</li> </ul> </li> </ul>
<p><b>I</b></p> <p>a0005138</p>	<ul style="list-style-type: none"> <li>■ Insertion version</li> <li>■ Sensor length 235/335/435/608 for DN 80 to 1500 (9.25"/13.2"/17.1"/23.9" for line size 3" to 60")</li> <li>■ Sensor body material:                             <ul style="list-style-type: none"> <li>1.4404, 316/316L</li> </ul> </li> <li>■ Transducer body material:                             <ul style="list-style-type: none"> <li>1.4404/316L, Alloy C22</li> </ul> </li> </ul>

## Input

### Measured variable

- Mass flow
- Gas temperature
- Gas heat flow

### Measuring range (air at ambient conditions)

The measuring range is dependant on the gas selection, line size and use of flow conditioner. Each meter is individually calibrated on air and mathematically converted to suit the customer specific gas, where required. The table below defines the ranges available for air without flow conditioner. Please refer to your Endress+Hauser representative or to Applicator, the selection tool, for other gases and process conditions.

Measuring range for the flanged version, metric units:

DN	kg/h		Nm <sup>3</sup> /h at 0°C, 1.013 bar a		scf/min. at 15°C, 1.013 bar a	
	min.	max.	min.	max.	min.	max.
15	0.5	53	0.38	41	0.23	25
25	2	200	1.5	155	1.0	96
40	6	555	4.6	429	3.0	266
50	10	910	7.7	704	5.0	436
80	20	2030	15.5	1570	10	974
100	38	3750	29	2900	18	1800

Measuring range for the flanged version, US units:

DN	lb/h		Sm <sup>3</sup> /h at 59 °F, 14.7 psi a		scf/min. at 59 °F, 14.7 psi a	
	minimum	maximum	minimum	maximum	minimum	maximum
½"	1.1	116	0.4	42	0.23	25
1"	4.4	440	1.6	160	1.0	96
1 ½"	13.2	1220	4.8	450	3.0	266
2"	22	2002	8	740	5.0	436
3"	44	4466	16	1656	10	974
4"	84	8250	30	3060	18	1800

Measuring range for the insertion version, metric units:

DN	kg/h		Nm <sup>3</sup> /h at 0°C, 1.013 bar a		scf/min. at 15°C, 1.013 bar a	
	min.	max.	min.	max.	min.	max.
80	20	2030	15.5	1570	9.6	974
100	38	3750	29.0	2900	18	1800
150	50	7500	38	5800	24	3600
200	80	12500	62	9666	38	6000
250	120	20000	93	15468	58	9600
300	180	28000	139	21655	86	13440
400	300	50000	232	38670	144	24000
500	500	80000	386	61870	240	38400
600	700	115000	540	88940	336	55200
700	900	159000	696	122970	432	76300
1000	2000	320000	1546	247846	960	153600
1500	2500	720000	1933	556844	1200	345600

In order to achieve optimum performance it is recommended that under operating conditions the maximum velocity is limited to a value below 70 m/sec.

The flowrates shown are representative of the calibrated conditions only and do not necessarily reflect what the meter can measure under operating conditions and actual internal pipe dimensions found on site. To correctly size and select a meter, it is recommended that you either contact your local Endress+Hauser representative or refer to the Endress+Hauser software package Applicator. Examples in metric units:

Line Size	Gas	Process pressure	Temperature	Max. Flowrate
DN		bar a	°C	kg/h
50	Air	1	25	910
50	Air	3	25	3300
50	CO <sub>2</sub>	1	25	1300
50	CO <sub>2</sub>	3	25	3950
50	Methane	1	25	795
50	Methane	3	25	1500

## Input signal

### Status input (auxiliary input) for HART version

U = 3 to 30 V DC,  $R_i = 5 \text{ k}\Omega$ , galvanically isolated; switch level  $\pm 3$  to  $\pm 30$  V DC;  
Configurable for: gas group, totalizer reset, positive zero return, start zero point adjustment

### Status input (auxiliary input) for PROFIBUS DP

U = 3 to 30 V DC,  $R_i = 3 \text{ k}\Omega$ , galvanically isolated; switch level:  $\pm 3$  to  $\pm 30$  V DC, independent of polarity.  
Configurable for: positive zero return, error message reset, zero point adjustment start.

### Status input (auxiliary input) for MODBUS RS485

U = 3 to 30 V DC,  $R_i = 3 \text{ k}\Omega$ , galvanically isolated; switch level:  $\pm 3$  to  $\pm 30$  V DC, independent of polarity.  
Configurable for: totalizer reset, positive zero return, error message reset, start zero point adjustment.

### Current input:

Active/passive selectable, galvanically isolated, resolution: 2  $\mu\text{A}$

- Active: 4 to 20 mA,  $R_i \leq 150 \text{ }\Omega$ ,  $U_{\text{out}} = 24 \text{ V DC}$ , short-circuit proof
- Passive: 0/4 to 20 mA,  $R_i \leq 150 \text{ }\Omega$ ,  $U_{\text{max}} = 30 \text{ V DC}$

Configurable for: pressure, gas analyzer

## Output

## Output signal

### Current output

Active/passive selectable, galvanically isolated, time constant selectable (0.0 to 100.0 s), full scale value selectable, temperature coefficient: typically 0.005% o.f.s./°C, resolution: 0.5  $\mu\text{A}$

- Active: 0/4 to 20 mA,  $R_L < 700 \text{ }\Omega$  (for HART:  $R_L \geq 250 \text{ }\Omega$ )
- Passive: 4 to 20 mA; supply voltage  $V_S$  18 to 30 V DC;  $R_i \geq 150 \text{ }\Omega$

If the current output is used as a temperature output, please observe the following information:  
Class B according to EN 6075

**Pulse/frequency output**

Active/passive selectable, galvanically isolated

- Active: 24 V DC, 25 mA (max. 250 mA during 20 ms),  $R_L > 100 \Omega$  (*Flexible I/O boards*, siehe terminal assignment → 9)
- Passive: Open Collector, 30 V DC, 250 mA
- Frequency output: full scale frequency 2 to 1000 Hz ( $f_{\max} = 1250$  Hz), on/off ratio 1:1, pulse width max. 2 s, time constant selectable (0.0 to 100.0 s)
- Pulse output: pulse value and pulse polarity can be selected, pulse width adjustable (0.5 to 2000 ms; factory setting 20 ms)

**PROFIBUS DP interface**

- PROFIBUS DP in accordance with EN 50170 Volume 2
- Profile Version 3.0
- Data transmission rate: 9.6 kBaud to 12 MBaud
- Automatic data transmission rate recognition
- Signal encoding: NRZ-Code
- Function blocks: 3 × Analog Input, 2 × Totalizer, 1 × Analog Output,
- Output data: Mass flow, Corrected volume flow, Temperature, Totalizers 1 to 2
- Input data: Positive zero return (ON/OFF), Zero point adjustment, Measuring mode, Totalizer control
- Bus address can be configured via miniature switches or via the local display (optional)
- Available output combination → 9

**PROFIBUS PA interface**

- PROFIBUS PA in accordance with EN 50170 Volume 2, IEC 61158-2 (MBP), galvanically isolated
- Data transmission rate: 31.25 kBit/s
- Current consumption: 11 mA
- Permitted supply voltage: 9 to 32 V
- Bus connection with integrated reverse polarity protection
- Error current FDE (Fault Disconnection Electronic): 0 mA
- Signal encoding: Manchester II
- Function blocks: 3 × Analog Input, 2 × Totalizer, 1 × Analog Output,
- Output data: Mass flow, Corrected volume flow, Temperature, Totalizers 1 to 2
- Input data: Positive zero return (ON/OFF), Zero point adjustment, Measuring mode, Totalizer control
- Bus address can be configured via miniature switches or via the local display (optional)
- Available output combination → 9

**MODBUS interface**

- MODBUS device type: slave
- Address range: 1 to 247
- Supported function codes: 03, 04, 06, 08, 16, 23
- Broadcast: supported with the function codes 06, 16, 23
- Physical interface: RS485 in accordance with EIA/TIA-485 standard
- Supported baud rate: 1200, 2400, 4800, 9600, 19200, 38400, 57600, 115200 Baud
- Transmission mode: RTU or ASCII
- Response times:
  - Direct data access = typically 25 to 50 ms
  - Auto-scan buffer (data range) = typically 3 to 5 ms
- Available output combination → 9

**FOUNDATION Fieldbus interface**

- FOUNDATION Fieldbus H1, IEC 61158-2, galvanically isolated
- Data transmission rate: 31.25 kBit/s
- Current consumption: 12 mA
- Permitted supply voltage: 9 to 32 V
- Error current FDE (Fault Disconnection Electronic): 0 mA
- Bus connection with integrated reverse polarity protection
- Signal encoding: Manchester II
- ITK Version 5.01
- Function blocks:
  - 7 × Analog Input (Execution time: each 18 ms)
  - 1 × Analog Output (Execution time: 18 ms)
  - 1 × Digital Output (18 ms)
  - 1 × PID (25 ms)
  - 1 × Arithmetic (20 ms)
  - 1 × Input Selector (20 ms)
  - 1 × Signal Characterizer (20 ms)
  - 1 × Integrator (18 ms)
- Number of VCRs: 38
- Number of link objects in VFD: 40
- Output data: Mass flow, Corrected volume flow, Temperature, Totalizers 1 to 3
- Input data: Positive zero return (ON/OFF), Zero point adjustment, Measuring mode, Reset totalizer
- Link Master (LM) function is supported
- Available output combination → 9

---

**Signal on alarm**

**Current output:**

Failsafe mode selectable (e.g. in accordance with NAMUR Recommendation NE 43)

**Current input:**

Failsafe value selectable

**Pulse/frequency output:**

Failsafe mode selectable

**Status output:**

"Non conductive" in the event of fault or power supply failure.

Relay output:

"De-energized" in the event of fault or power supply failure.

**PROFIBUS DP:**

Status and alarm messages in accordance with PROFIBUS Profile Version 3.0.

**MODBUS RS485:**

If an error occurs, the value NaN (not a number) is output for the measured values.

---

**Load**

see "Output signal"

---

**Low flow cut off**

Switch points for low flow cut off are programmable

---

**Galvanic isolation**

All circuits for inputs, outputs, and power supply are galvanically isolated from each other.

---

**Switching output**

**Relay output:**

Normally closed (NC) or normally open (NO) contacts available  
 (factory setting: relay 1 = NO, relay 2 = NC), max. 30 V / 0.5 A AC; 60 V / 0.1 A DC, galvanically isolated.  
 Configurable for: error messages, limit values

## Power supply

Electrical connection  
Measuring unit

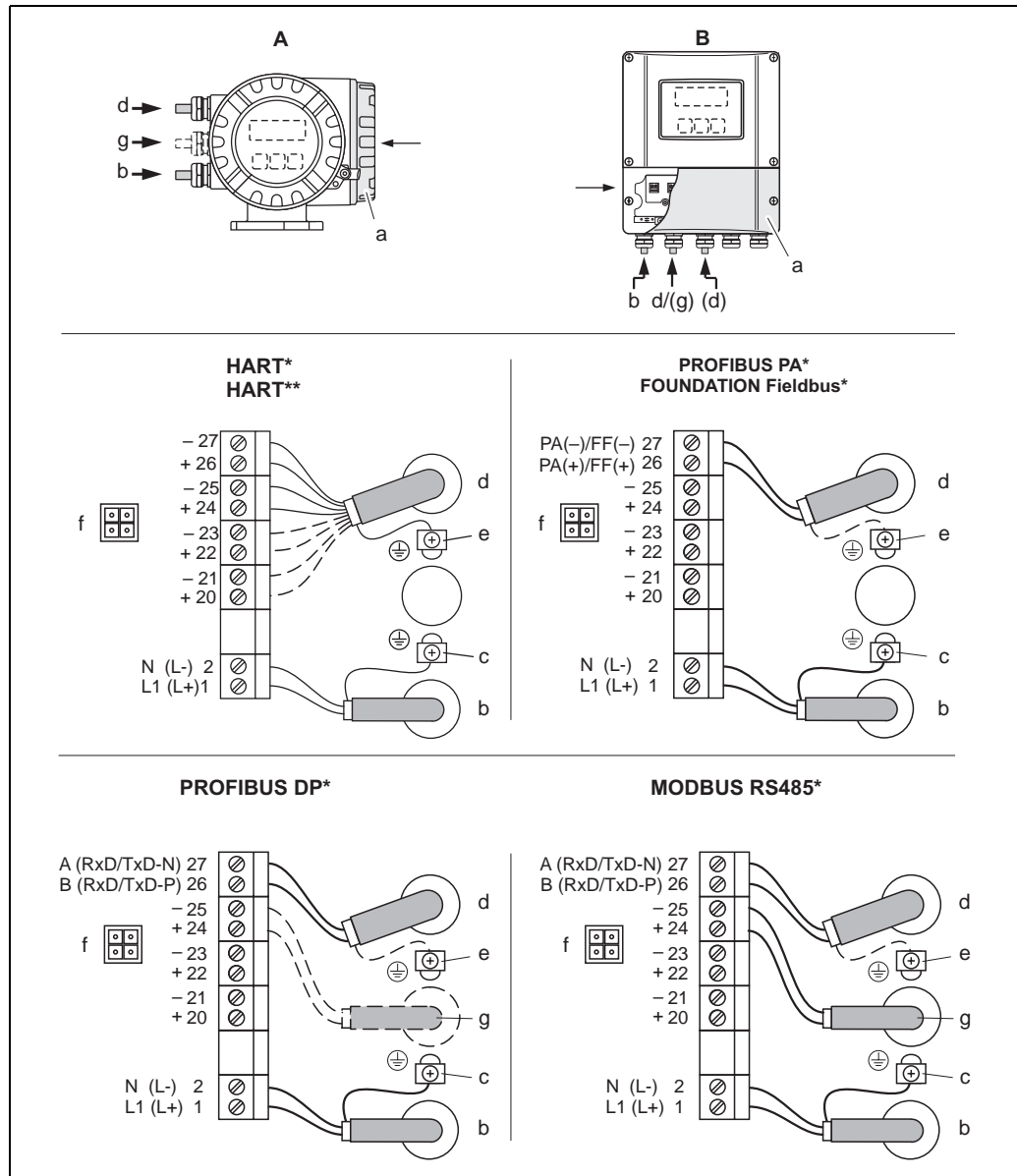

a0005135

Connecting the transmitter, cable cross-section: max. 2.5 mm<sup>2</sup>

A View A (field housing)

B View C (wall-mount housing)

\*) fixed communication board

\*\*) flexible communication board

a Connection compartment cover

b Cable for power supply: 85 to 260 V AC, 20 to 55 V AC, 16 to 62 V DC

Terminal No. 1: L1 for AC, L+ for DC

Terminal No. 2: N for AC, L- for DC

c Ground terminal for protective ground

d Signal cable: see Terminal assignment → 9

Fieldbus cable:

Terminal No. 26: DP (B) / PA (+) / FF (+) / MODBUS RS485 (B) / (PA, FF: with reverse polarity protection)

Terminal No. 27: DP (A) / PA (-) / FF (-) / MODBUS RS485 (A) / (PA, FF: with reverse polarity protection)

e Ground terminal for signal cable shield / fieldbus cable / RS485 line

f Service adapter for connecting service interface FXA 193 (Fieldcheck, FieldCare)

g Signal cable: see Terminal assignment → 9

Cable for external termination (only for PROFIBUS DP with permanent assignment communication board):

Terminal No. 24: +5 V

Terminal No. 25: DGND



## Terminal assignment

Order version	Terminal No. (inputs/outputs)			
	20 (+) / 21 (-)	22 (+) / 23 (-)	24 (+) / 25 (-)	26 (+) / 27 (-)
<i>Fixed communication boards (permanent assignment)</i>				
65F**_*****A 65I-*****A	-	-	Frequency output	Current output HART
65F**_*****B 65I-*****B	Relay output	Relay output	Frequency output	Current output HART
65**_*****F 65I-*****F	-	-	-	PROFIBUS PA, Ex i
65**_*****G 65I-*****G	-	-	-	FOUNDATION Fieldbus Ex i
65**_*****H 65I-*****H	-	-	-	PROFIBUS PA
65**_*****J 65I-*****J	-	-	+5V (ext. termination)	PROFIBUS DP
65**_*****K 65I-*****K	-	-	-	FOUNDATION Fieldbus
65**_*****Q 65I-*****Q	-	-	Status input	MODBUS RS485
65F**_*****R 65I-*****R	-	-	Current output 2 Ex i, active	Current output 1 Ex i active, HART
65F**_*****S 65I-*****S	-	-	Frequency output Ex i, passive	Current output Ex i Active, HART
65F**_*****T 65I-*****T	-	-	Frequency output Ex i, passive	Current output Ex i Passive, HART
65F**_*****U 65I-*****U	-	-	Current output 2 Ex i, passive	Current output 1 Ex i passive, HART
<i>Flexible communication boards</i>				
65F**_*****C 65I-*****C	Relay output 2	Relay output 1	Frequency output	Current output HART
65F**_*****D 65I-*****D	Status input	Relay output	Frequency output	Current output HART
65F**_*****E 65I-*****E	Status input	Relay output	Current output 2	Current output 1 HART
65F**_*****L 65I-*****L	Status input	Relay output 2	Relay output 1	Current output HART
65F**_*****2 65I-*****2	Relay output	Current output 2	Frequency output	Current output 1 HART
65F**_*****4 65I-*****4	Current input	Relay output	Frequency output	Current output HART
65F**_*****5 65I-*****5	Status input	Current input	Frequency output	Current output HART
65F**_*****6 65I-*****6	Status input	Current input	Current output 2	Current output 1 HART
65F**_*****8 65I-*****8	Status input	Frequency output	Current output 2	Current output HART

## Electrical connection Remote version

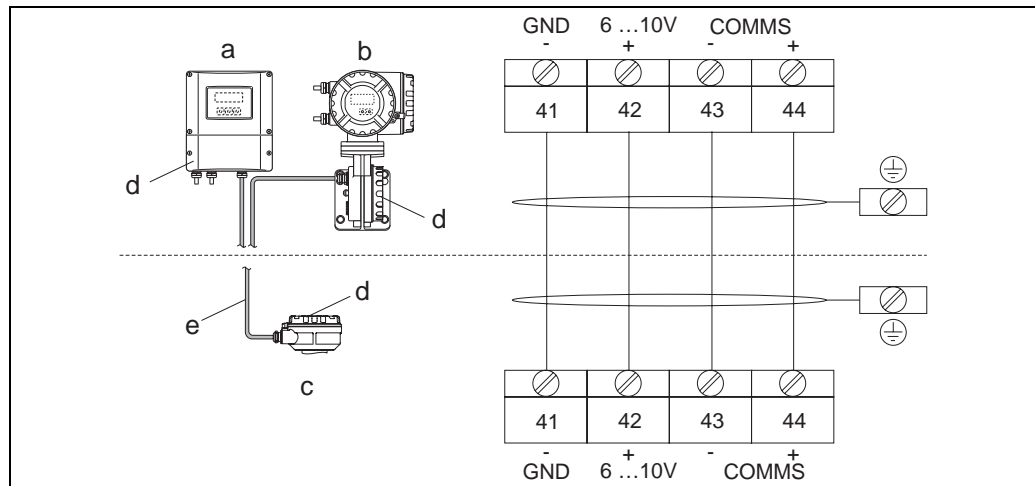

### Connecting the remote version

- a Wall-mount housing transmitter: non-hazardous area and ATEX II3G / zone 2 → see separate "Ex documentation"  
 b Wall-mount housing transmitter: ATEX II2G / Zone 1; FM/CSA → see separate "Ex documentation"  
 c Connection housing sensor  
 d Cover for connection compartment or connection housing  
 e Connecting cable

### Terminal No.:

41 = white; 42 = brown; 43 = green; 44 = yellow

## Supply voltage

85 to 260 V AC, 45 to 65 Hz  
 20 to 55 V AC, 45 to 65 Hz  
 16 to 62 V DC

## Cable entries

### Power-supply and signal cables (inputs/outputs):

- Cable entry M20 × 1.5 (8 to 12 mm / 0.31" to 0.47")
- Thread for cable entries, 1/2" NPT, G 1/2"

### Connecting cable for remote version:

- Cable entry M20 × 1.5 (8 to 12 mm / 0.31" to 0.47")
- Thread for cable entries, 1/2" NPT, G 1/2"

## Remote version cable specifications

- 2 × 2 × 0.5 mm<sup>2</sup> (AWG 20) PVC cable with common shield (2 twisted pairs)
- Conductor resistance: ≤ 40 Ω/km [≤ 131.2 Ω / 1000 ft]
- Capacitance, core/shield: ≤ 0.001 μF/m [≤ 3.280 nF/ft]
- Inductance: ≤ 0.9 μH/m [≤ 2.952 μH/ft]
- Operating voltage: ≥ 250 V
- Temperature range: -40 to +105 °C [-40 to +221 °F]
- Overall nominal diameter: 8.5 mm [0.335"]
- Maximum cable length: 100 m [328 feet]

Operation in zones of severe electrical interference:

The measuring device complies with the general safety requirements in accordance with EN 61010, the EMC requirements of IEC/EN 61326, and NAMUR recommendation NE 21/43.

For cable specifications for hazardous area devices please see the additional Ex documentation.

## Power consumption

AC: 85 to 260 V = 18.2 W ; 20 to 55 V = 14 W ; (including sensor)  
 DC: 8 W (including sensor)

<b>Power supply failure</b>	<p>Lasting minimum 1 power cycle</p> <ul style="list-style-type: none"> <li>■ EEPROM/HistoROM T-DAT saves measuring system data if the power supply fails</li> <li>■ HistoROM S-DAT is on exchangeable data storage chip with sensor specific data (pipe type, nominal diameter, serial number, flow conditioner, zero point, etc.)</li> <li>■ Totalizer stops at the last value determined</li> </ul>
-----------------------------	--

<b>Potential equalization</b>	<p>No special measures for potential equalization are required. For instruments for use in hazardous areas, observe the corresponding guidelines in the specific Ex documentation.</p>
-------------------------------	--

## Performance characteristics

<b>Calibration reference conditions</b>	<ul style="list-style-type: none"> <li>■ Accredited according to ISO/IEC 17025</li> <li>■ Traceable to National Standards</li> <li>■ Calibration gas: air</li> <li>■ Temperature controlled to 24 °C ±0.5 °C (75.2 °F ± 0.9 °F) at atmospheric pressure</li> <li>■ Humidity controlled &lt; 40% RH</li> </ul>
---	---

<b>Maximum measured error</b>	<p>t-mass 65F: ±1.5 % of reading for 100 % to 10 % of full scale (at reference conditions) ±0.15 % of full scale for 10 % to 1 % of full scale (at reference conditions)</p> <p>t-mass 65I: ±1.0% of reading ±0.5% of full scale (at reference conditions)</p>
-------------------------------	--

<b>Repeatability</b>	±0.4 % of reading for velocities above 1.0 m/s (3.3 ft/s)
----------------------	---

<b>Influence of medium pressure (Pressure co-efficient)</b>	<p>Air: 0.35% per bar (0.02% per psi) of process pressure change Other gases: on request</p>
---	--

<b>Response time</b>	Typically less than 2 seconds for 63 % of a given step change (in either direction).
----------------------	--

## Operating conditions: Installation

Thermal meters require a fully developed flow profile as a prerequisite for correct flow measurement. For this reason, please note the following points when installing the device.

### Installation instructions

#### Orientation

- The thermal dispersion principle is sensitive to disturbed flow conditions.
- Observe the recommended inlet and outlet requirements.
- Good engineering practice is necessary for the associated pipe work and installation.
- Ensure correct alignment and orientation of the sensor.
- Take measures to reduce or avoid condensation (e.g. install a condensation trap, thermal insulation, etc.).
- The maximum permitted ambient temperatures and the medium temperature range (→ 19) must be observed.
- Install the transmitter in a shaded location or use a protective sun shield.
- For mechanical reasons, and in order to protect the pipe, it is advisable to support heavy sensors.

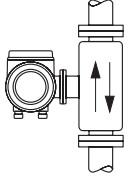
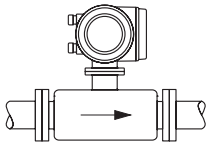
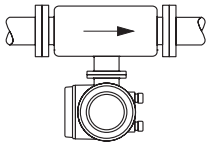
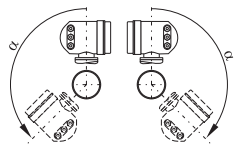
	Flanged sensor		Insertion sensor	
<b>Vertical orientation</b>				
 A0013785	compact	remote	compact	remote
	✓✓ ①	✓✓ ①	✓ ①, ②	✓✓ ①
<b>Horizontal orientation, transmitter head up</b>				
 A0013786	compact/remote			
	✓✓ ②			
<b>Horizontal orientation, transmitter head down</b>				
 A0013787	compact/remote			
	✓ ③			
<b>Inclined orientation, transmitter head down</b>				
 A0009807	compact/remote			
	✓ ④			

✓✓ = Recommended orientation

✓ = Orientation recommended in certain situations

① In the case of saturated or unclean gases, upward flow in a vertical pipe section is preferred to minimize condensation/contamination.

② Not recommended if the vibrations are too high or if the installation is unstable.

③ Only suitable for clean/dry gases. Do not mount the sensor from the bottom, on horizontal pipes, if build-ups or condensate are likely to be present. Mount the sensor in a position as indicated below

④ If the gas is very damp or saturated with water (e. g. Bio Gas), mount in inclined orientation ( $\alpha = \max. 135^\circ$ ).

### Thermal insulation

When the gas is very humid or saturated with water (e. g. Bio Gas), the piping and flowmeter body should be insulated to prevent water droplets condensing on the measuring sensor.

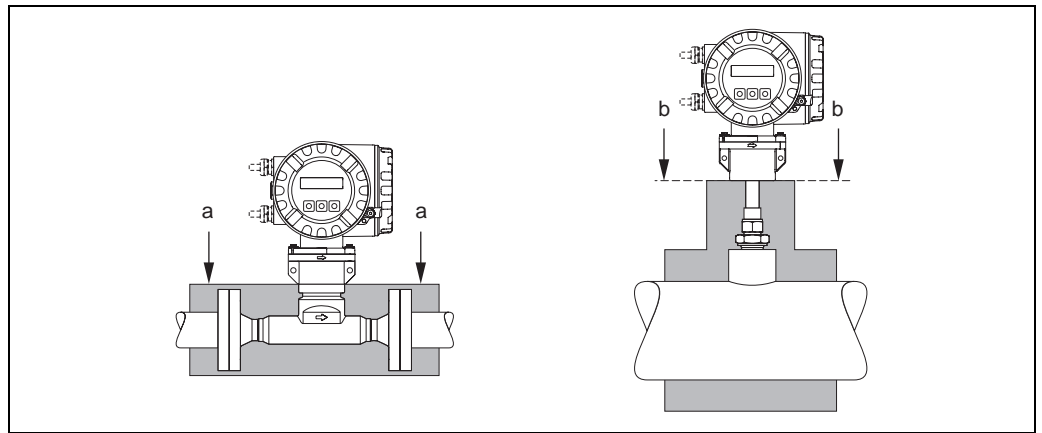

40005122

*Maximum thermal insulation for t-mass 65F and 65I*

*a Maximum insulation height for the flanged sensor*

*b Maximum insulation height for the insertion sensor*

## Inlet and outlet runs

The thermal dispersion principle is sensitive to disturbed flow conditions.

As a general rule, the thermal flowmeter should always be installed as far away as possible from any flow disturbances. For further information please refer to ISO 14511.

- Where two or more flow disturbances are located upstream of the meter, the recommended inlet length for the flow disturbance causing strongest disturbance must be used. E.g. where a valve is mounted before a bend, upstream of the flowmeter,  $50 \times \text{DN}$  of pipe work is required from the valve to the flowmeter.
- For very light gases such as Helium and Hydrogen all upstream distances should be doubled.

**The minimum recommendations for inlet and outlet runs (without flow conditioner) are:**

Flanged sensor

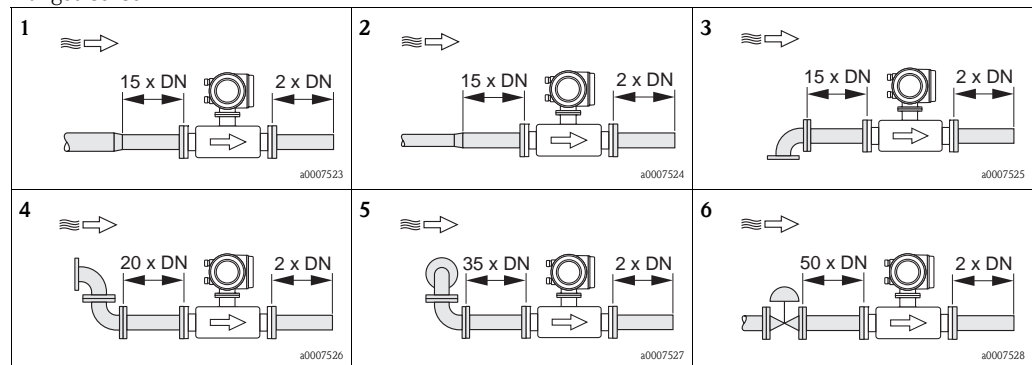

1 = Reduction, 2 = Expansion, 3 =  $90^\circ$  elbow or T-piece, 4 =  $2 \times 90^\circ$  elbow, 5 =  $2 \times 90^\circ$  elbow (3-dimensional), 6 = Control valve

Insertion sensor

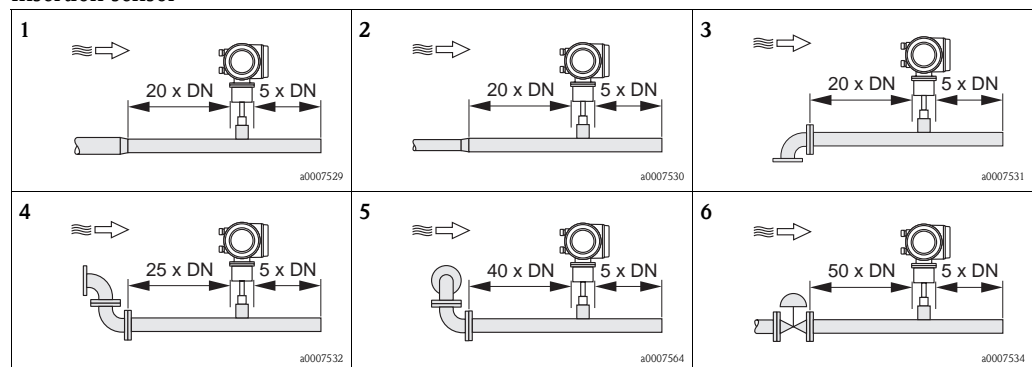

1 = Reduction, 2 = Expansion, 3 =  $90^\circ$  elbow or T-piece, 4 =  $2 \times 90^\circ$  elbow, 5 =  $2 \times 90^\circ$  elbow (3-dimensional), 6 = Control valve or pressure regulator

A specially designed perforated plate flow conditioner can be installed if it is not possible to observe the inlet runs required ( $\rightarrow$  15).

### Outlet runs with pressure measuring points

The pressure measuring point should be installed downstream of the measuring device, so that there is no potential influence of the pressure transmitter process connection on the flow entering the measuring point.

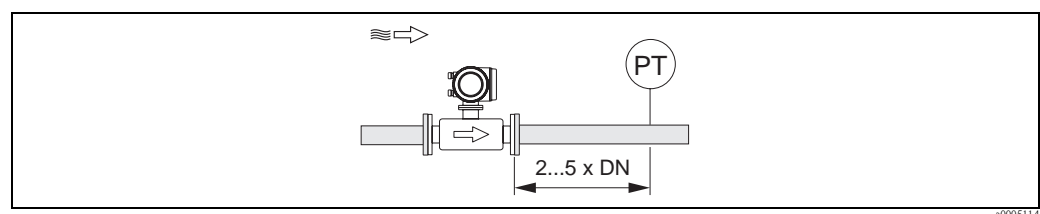

Installing a pressure measuring point (PT = pressure transmitter)

### Perforated plate flow conditioner

It is recommended to install a perforated plate flow conditioner if the recommended inlet runs are not available.

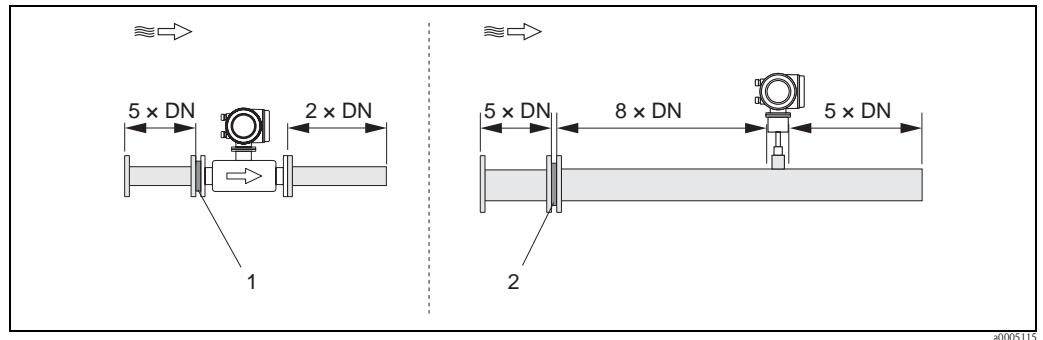

The figure above illustrates the minimum recommended inlet and outlet runs expressed in multiples of the pipe diameter using a flow conditioner.

1 = Flow conditioner with the flanged sensor, 2 = Flow conditioner with the insertion sensor

#### Flow conditioner for use with insertion sensors 65I → 41

The well known "Mitsubishi" design is recommended for this application DN 80 mm to DN 300 mm (3" to 12"). The flow conditioner must be installed at a distance of  $8 \times DN$  upstream of the sensor. A further 5 pipe diameters inlet run is required upstream of the actual conditioner itself.

#### Flow conditioner for use with flanged sensors 65F → 41

This is a special Endress+Hauser version designed specially for use with the t-mass F sensor (sizes DN 25 to 100 / 1" to 4"). The mounting hole patterns and sizing are of a multi-variant design which means that one plate will fit different flange pressure classes e.g. Cl. 150 and Cl. 300.

The flow conditioner and gaskets are fitted between two pipe flange and the flow meter flange. Use only bolts which match to the flange bolt hole and this will ensure that the correct positioning of the plate can be found.

The alignment notch must also be pointing in the same plane as the transmitter.

Incorrect installation of the flow conditioner will have a small effect on the measurement accuracy.

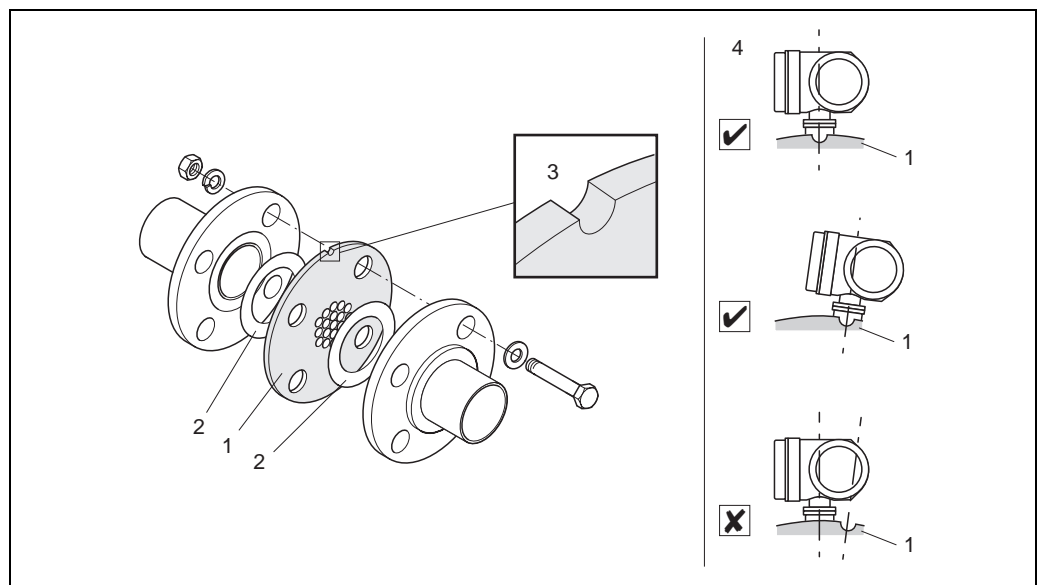

Flow conditioner mounting arrangement (example)

1 = Perforated plate flow conditioner, 2 = Seal/gasket, 3 = Notch, 4 = correct pointing of alignment notch in the same plane as the transmitter

## Note

- For optimum performance, it is advised that the t-mass F sensor and flow conditioner are ordered at the same time such that they are calibrated together. To retrospectively fit a flow conditioner will have a small effect on the measurement performance.
- The use of other types of flow conditioners, other than the Endress+Hauser flow conditioner, with the t-mass F sensor will have an impact on the measurement performance due to the effects of flow profile and pressure drop.
- Bolts, nuts, seals, etc. are not included in the scope of supply and must be supplied by the customer.

## Pressure loss calculation

$$\Delta p = \text{constant} \cdot \frac{\dot{m}^2}{\rho} \cdot \frac{1}{D^4}$$

Pressure loss:  $\Delta p$  in mbar or psi

Mass flow :  $\dot{m}$  in kg/h or lbm/h

Density:  $\rho$  in kg/m<sup>3</sup> or lbm/ft<sup>3</sup>

Diameter: D in mm or inch

Constant = 1876 (SI units) or  $8.4 \cdot 10^{-7}$  (US units)

Calculation examples:

$\dot{m} = 148$  kg/h or 326 lbm/h

$\rho = 5.94$  kg/m<sup>3</sup> (at 5 bar abs at 20 °C) or 0.37 lbm/ft<sup>3</sup> (at 72.5 psi abs at 68 °F)

D = 28.5 mm (for a DN 25, PN 40) or 1.05 inch (for a 1" Class 150 Sched 40)

SI units

$$\Delta p = 1876 \cdot \frac{148^2}{5.94} \cdot \frac{1}{28.5^4} = 10.5 \text{ mbar}$$

US units

$$\Delta p = 8.4 \cdot 10^{-7} \cdot \frac{326^2}{0.371} \cdot \frac{1}{1.05^4} = 0.198 \text{ psi}$$

## Pipework requirements

Good engineering practice should be followed at all times:

- Correct preparation, welding and finishing techniques
- Correctly sized gaskets
- Correctly aligned flanges and gaskets
- Connecting pipe work should match the internal diameter of the flowmeter.
  - Maximum pipe diameter mismatch should not exceed:
    - 1 mm (0.04 inch) for diameters < DN 200 (8")
    - 3 mm (0.12 inch) for diameters ≥ DN 200 (8")
- New installations should be free of metallic and abrasive particles to prevent damage to the sensing elements on start-up

For further information please refer to ISO 14511.

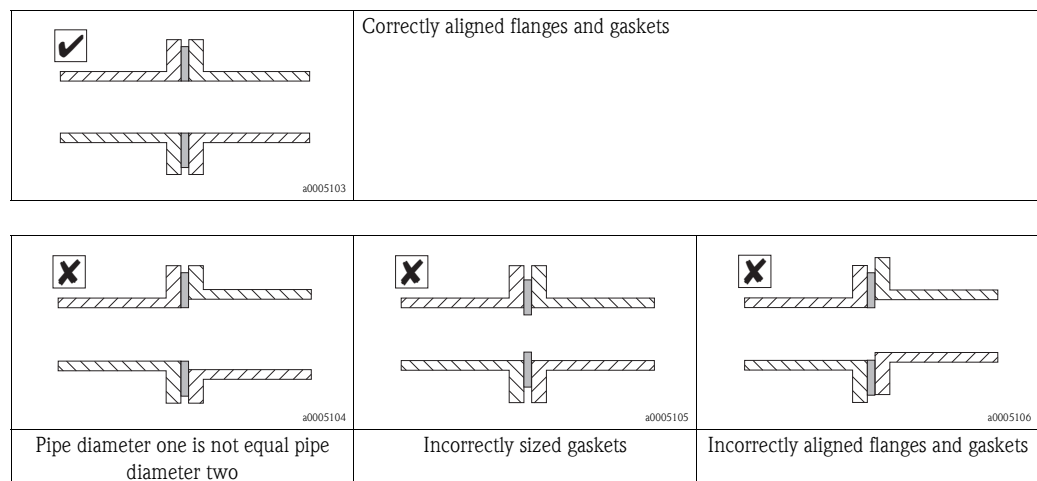



**Mounting conditions for the insertion version**

**Selecting the length of the insertion sensor**

The minimum required length of the insertion sensor can be determined by using Endress+Hauser's sizing tool, Applicator (version 10.02 or later "Accessories") or according to the following calculation steps.

The minimum required length of the insertion sensor is determined by the necessary insertion depth. The calculated insertion depth must lie within the adjustable range of the selected insertion sensor.

1. Determine the dimensions A, B, C1 and C2

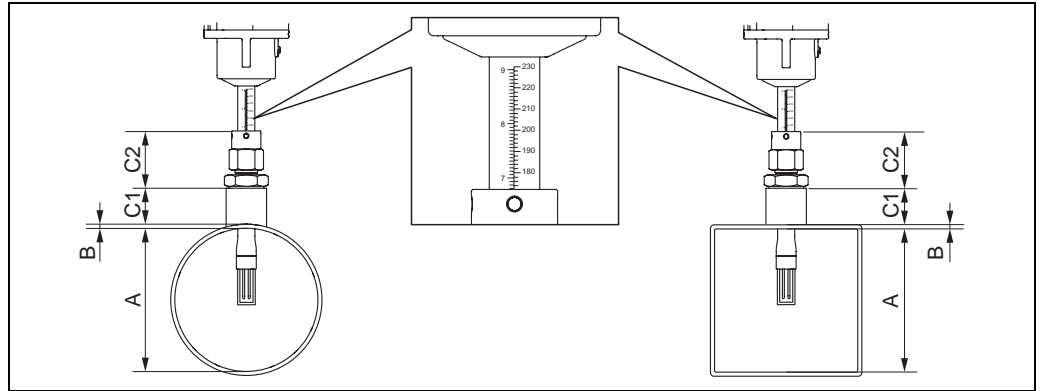

- A = For circular pipes: the internal pipe diameter (DN)  
For rectangular pipes/ducts: the inner dimension
- B = Wall thickness of pipe or duct
- C1+C2 = Length of mounting set and insertion tube's compression fitting

*Determine the dimensions C1 and C2*

If only Endress+Hauser accessories are used	
DK6MB-BXA Mounting boss G1A:	C1 + C2 = 106 mm (4.173 inch)
DK6MB-AXA Mounting boss 1" NPT:	C1 + C2 = 112 mm (4.409 inch)

If it is intended <b>not</b> to use solely Endress+Hauser accessories	
C1	Height of pipe connection (mounting boss) used
C2	46mm (1.811 inch) process connection, G1A threaded fitting
	52mm (2.047 inch) process connection, NPT threaded fitting

2. Calculate the insertion depth  

$$\text{Insertion depth} = (0,3 \cdot A) + B + (C1 + C2) + 2 \text{ mm}$$

$$(\text{Insertion depth} = (0,3 \cdot A) + B + (C1 + C2) + 0.079 \text{ inch})$$
3. A suitable insertion sensor length can be determined by comparing the calculated insertion depth with the following table. The calculated insertion depth must be within the adjusting range of the corresponding insertion sensor length!

Insertion length		Adjusting range (insertion depth)			
		G1A Thread		NPT Thread	
mm	inch	mm	inch	mm	inch
235	9	120 to 230	4.7 to 9.0	126 to 230	4.96 to 9.0
335	13	120 to 330	4.7 to 13.0	126 to 330	4.96 to 13.0
435	17	120 to 430	4.7 to 17.0	126 to 430	4.96 to 17.0
608	24	120 to 604	4.7 to 23.8	126 to 604	4.96 to 23.8

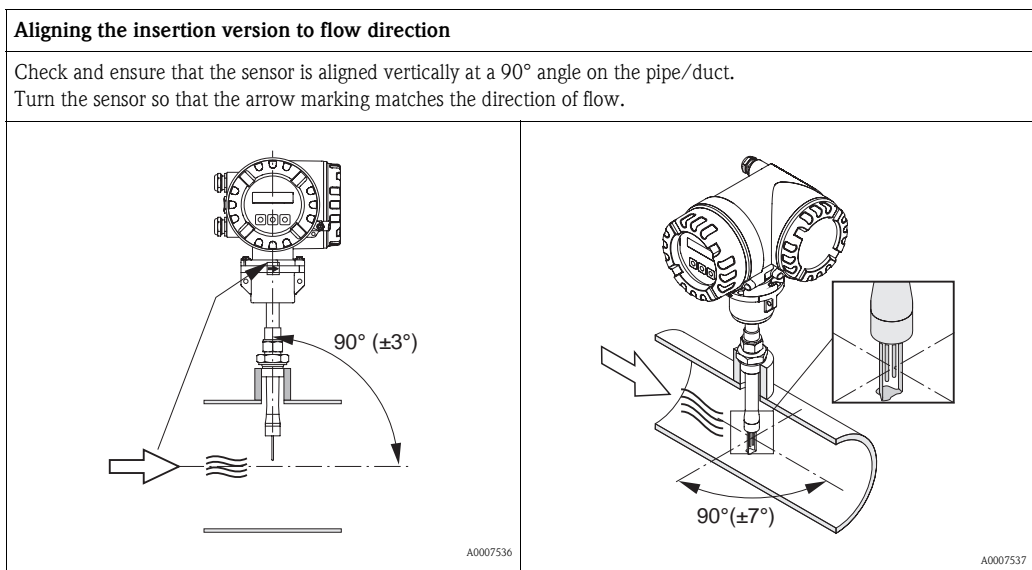
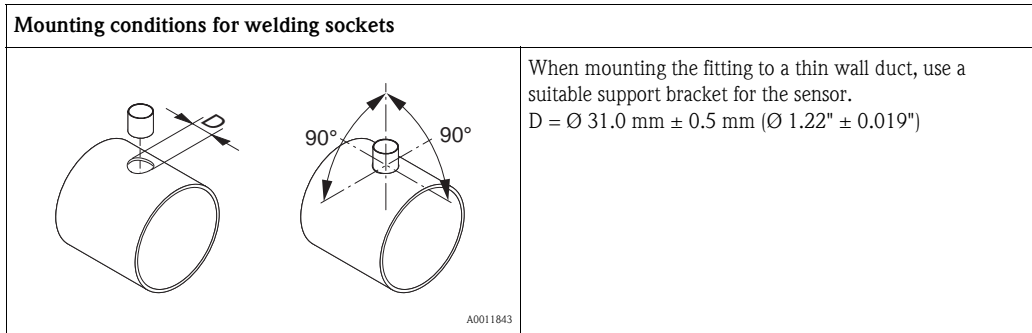

**Length of connecting cable** Max. 100 m (328 feet), remote version

## Operating conditions: Environment

**Ambient temperature** Standard:  $-20\text{ °C}$  to  $+60\text{ °C}$  ( $-4\text{ °F}$  to  $+140\text{ °F}$ )  
 Optional:  $-40\text{ °C}$  to  $+60\text{ °C}$  ( $-40\text{ °F}$  to  $+140\text{ °F}$ )

- Install the device in a shady location. Avoid direct sunlight, particularly in warm climatic regions.  
 (A protective sun cover is available on request)
- At ambient temperatures below  $-20\text{ °C}$  ( $-4\text{ °F}$ ) the readability of the display may be impaired.

**Storage temperature**  $-40$  to  $+80\text{ °C}$  ( $-40$  to  $+176\text{ °F}$ ), recommended:  $+20\text{ °C}$  ( $+68\text{ °F}$ )

**Degree of protection** Standard: IP 67 (NEMA 4X) for transmitter and sensor

**Shock resistance** According to IEC 60068-2-31

**Vibration resistance** Acceleration up to 1 g, 10 to 150 Hz, following IEC 60068-2-6

**Electromagnetic compatibility (EMC)** To IEC/EN 61326 and NAMUR recommendation NE 21

## Operating conditions: Process

<b>Medium temperature range</b>	<p><b>Sensor</b></p> <p>t-mass F: -40 °C to +100 °C (-40 °F to +212 °F)</p> <p>t-mass I: -40 °C to +130 °C (-40 °F to +266 °F)</p> <p><b>Seals t-mass F</b></p> <p>O-rings: Viton FKM -20°C to +100°C (-4°F to +212°F) Kalrez -20°C to +100°C (-4°F to +212°F) EPDM -40°C to +100°C (-40°F to +212°F)</p> <p>Bushing: PEEK, PVDF -40°C to +100°C (-40°F to +212°F)</p> <p><b>Seals t-mass I</b></p> <p>Bonded seals: Kalrez -20°C to +130°C (-4°F to +266°F) EPDM -40°C to +130°C (-40°F to +266°F) Nitrile -35°C to +130°C (-31°F to +266°F)</p> <p>Ferrule: PEEK, PVDF -40°C to +130°C (-40°F to +266°F)</p>
<b>Pressure loss</b>	<p>Negligible (without flow conditioner). Refer to Applicator for the precise calculation</p>
<b>Medium pressure range (nominal pressure)</b>	<p>t-mass F: -0.5 to 40 bar gauge (-7.25 to 580 psi gauge)</p> <p>t-mass I: -0.5 to 20 bar gauge (-7.25 to 290 psi gauge)</p>
<b>Flow limit</b>	<p>See "Measuring range" section. →  4 The velocity in the measuring tube should not exceed 130 m/s (427 ft/s).</p>
<b>Process conditions for Hot tap</b>	<p>The Hot tap is permitted for use only with non-toxic, innocuous gases classified as "Group II" in accordance with the European directive 67/548/EWG art. 2.</p> <p><b>Medium pressure version</b> Max. process pressure: 20 bar (290 psig) Max. extraction press: 16 bar (230 psig) Max. extraction temperature: +50°C (+122°F) Min. sensor length: 435 mm (17 inch)</p> <p><b>Low pressure version</b> Max. process pressure: 20 bar (290 psig) Max. extraction press: 4,5 bar (65 psig) Max. extraction temperature: +50°C (+122°F) Min. sensor length: 435 mm (17 inch)</p>

## Mechanical construction

### Design, dimensions

Dimensions:	
Transmitter remote version, connection housing (II2G/Zone 1), flange version	→ 20
Transmitter remote version, connection housing (II2G/Zone 1)	→ 21
Transmitter remote version, wall-mount housing (non Ex-zone and II3G/Zone 2)	→ 22
Installing the wall-mount housing	→ 23
Process connections in SI units	
t-mass 65F: Flange connections EN (DIN), JIS	→ 24
t-mass 65F: Flange connections ANSI	→ 26
t-mass 65I: Compact insertion version	→ 28
t-mass 65I: Remote sensor housing insertion version	→ 28
Flow conditioner according to EN (DIN) / JIS / ANSI	→ 29
Hot tap	→ 30
Process connections in US units	
t-mass 65F: Flange connections ANSI	→ 31
t-mass 65I: Compact insertion version	→ 33
t-mass 65I: Remote sensor housing insertion version	→ 33
Flow conditioner according to ANSI	→ 34
Hot tap	→ 35

### Transmitter remote version, connection housing (II2G/Zone 1), flange version

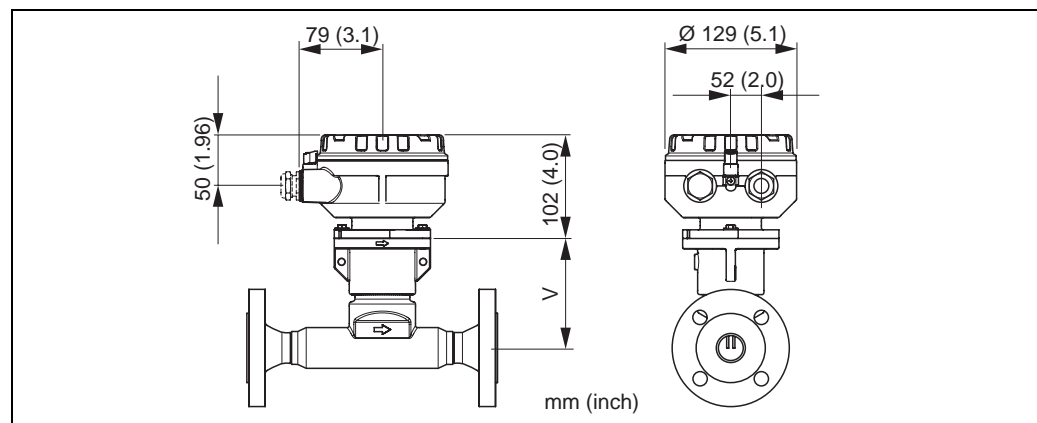

Dimensions "V": → 24 and → 26

**Transmitter remote version, connection housing (II2G/Zone 1)**

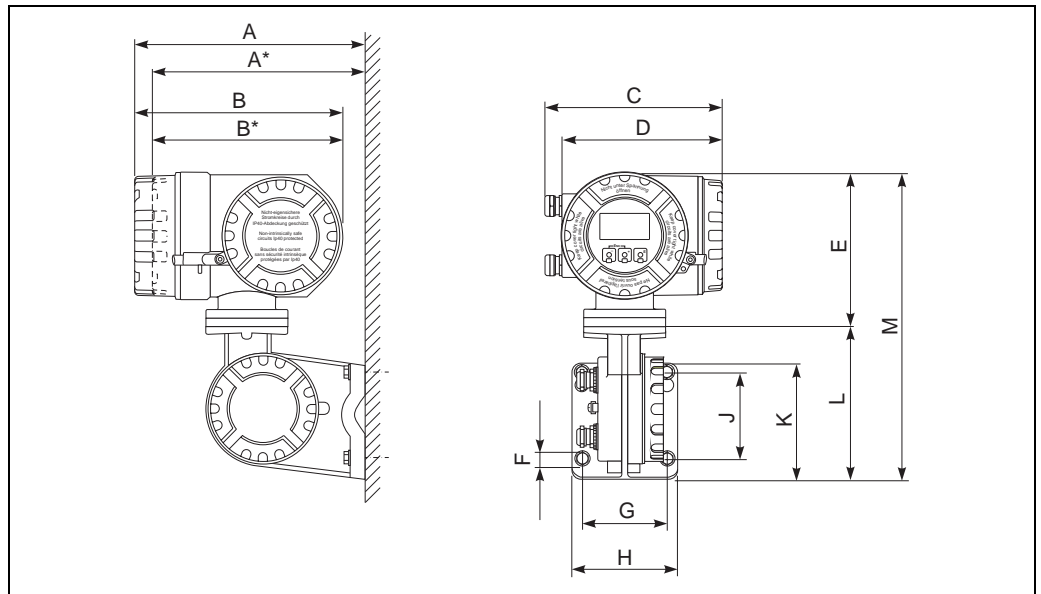

a0006999

*Dimensions in SI units*

A	A*	B	B*	C	D	E	F Ø	G	H	J	K	L	M
265	242	240	217	206	186	178	8.6 (M8)	100	130	100	144	170	348

\* Blind version (without display)

All dimensions in [mm]

*Dimensions in US units*

A	A*	B	B*	C	D	E	F Ø	G	H	J	K	L	M
10.4	9.53	9.45	8.54	8.11	7.32	7.01	0.34 (M8)	3.94	5.12	3.94	5.67	6.69	13.7

\* Blind version (without display)

All dimensions in [inch]

*Pipe mounting of the remote field housing*

If a warm pipe is used for installation, make sure that the housing temperature does not exceed the max. permitted value of +60 °C (+140 °F).

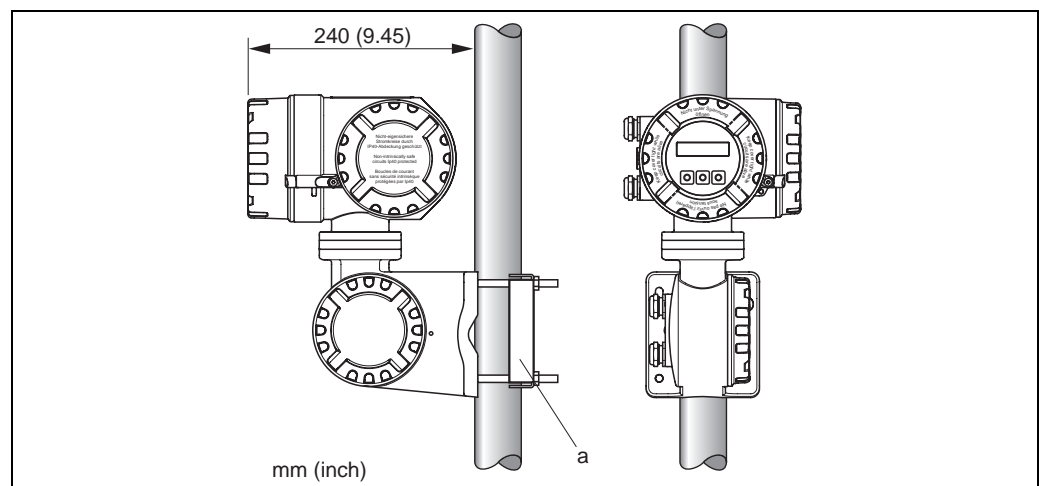

a0005157

a = Pipe mounting (separate mounting set, see accessories)

## Transmitter remote version, wall-mount housing (non Ex-zone and II3G/Zone 2)

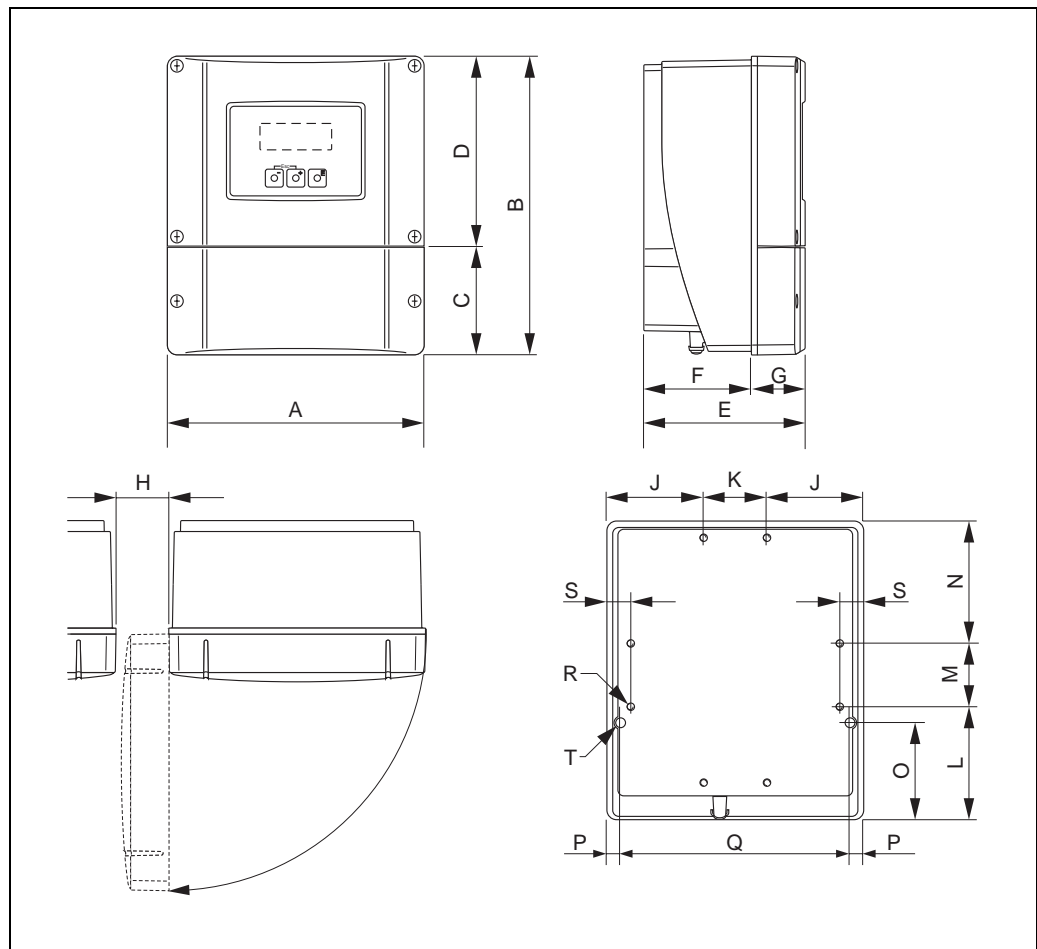

a0001150

## Dimensions in SI units

A	B	C	D	E	F	G	H	J	K
215	250	90.5	159.5	135	90	45	>50	81	53
L	M	N	O	P	Q	R	S	T <sup>1)</sup>	
95	53	102	81.5	11.5	192	8 × M5	20	2 × Ø 6.5	

<sup>1)</sup> Fixing bolt for wall assembly: M6 (screw head max. 10.5 mm)

All dimensions in [mm]

## Dimensions in US units

A	B	C	D	E	F	G	H	J	K
8.46	9.84	3.56	6.27	5.31	3.54	1.77	>1.97	3.18	2.08
L	M	N	O	P	Q	R	S	T <sup>1)</sup>	
3.74	2.08	4.01	3.20	0.45	7.55	8 × M5	0.79	2 × Ø 0.26	

<sup>1)</sup> Fixing bolt for wall assembly: M6 (screw head max. 0.41 inch)

All dimensions in [inch]

### Installing the wall-mount housing

- Make sure that ambient temperature does not go beyond the permissible range  
 -20 to +60 °C (-4 to +140 °F), optional -40 to +60 °C (-40 to +140 °F).
- Install the device in a shady location. Avoid direct sunlight.
- Always install the wall-mount housing in such a way that the cable entries are pointing down.

*Mounted directly on the wall*

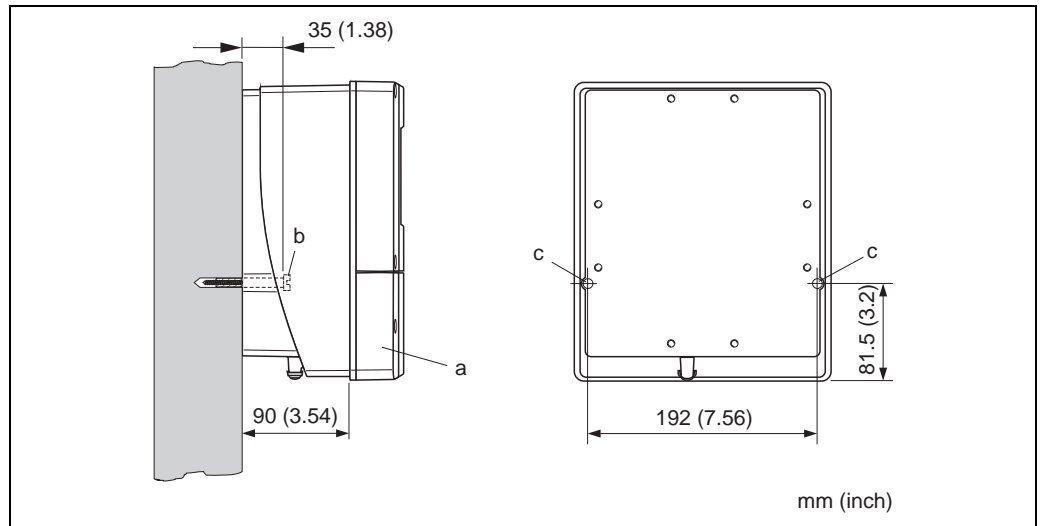

*a = Cover of the connection compartment*

*b = Securing screws (M6): max. Ø 6.5 mm (0.26"); screw head: max. Ø 10.5 mm (0.41")*

*c = Appropriate bores in the housing.*

### *Pipe mounting and installation in control panel*

If a warm pipe is used for installation, make sure that the housing temperature does not exceed the maximum permitted value of +60 °C. (+140 °F).

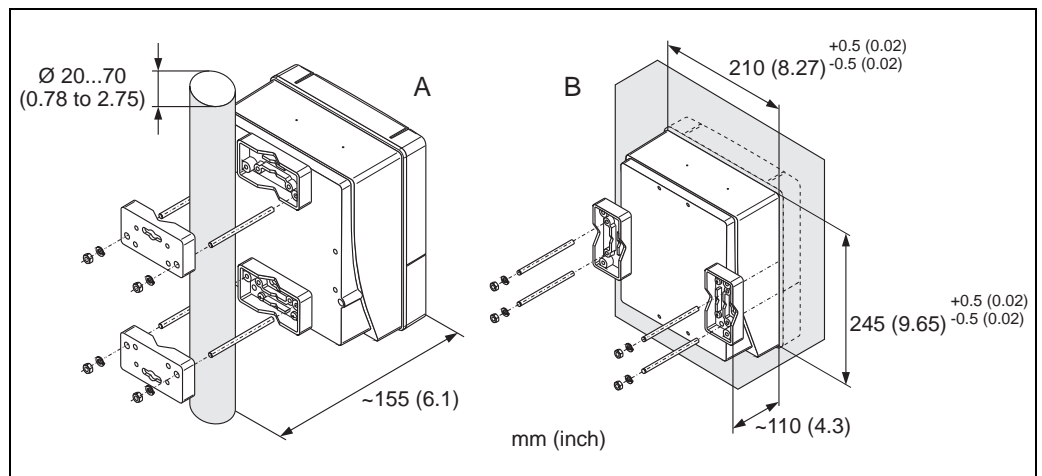

*A = Pipe mounting of wallmount housing*

*B = Installation in control panel of wallmount housing*

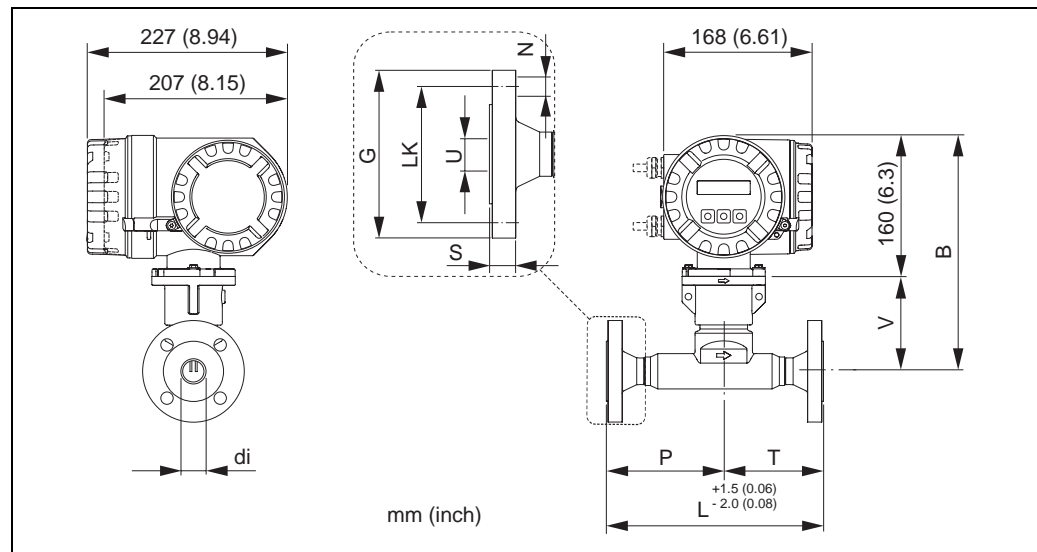
**Process connections in SI units**
*t-mass 65F: Flange connections EN (DIN), JIS*

a0005162

**Flange EN 1092-1 (DIN 2501 / DIN 2512N <sup>1)</sup>) / PN 16: 1.4404/316L/316**

 Surface roughness (flange): EN 1092-1 Form B1 (DIN 2526 Form C), Ra 6.3 to 12.5  $\mu\text{m}$ 

DN	di	B	G	L	LK	N	P	S	T	U	V
100	97	303	220	800	180	8 × Ø18	500.5	20	299.5	107.1	143

<sup>1)</sup> Flange with groove to EN 1092-1 Form D (DIN 2512N) available  
All dimensions in [mm]

**Flange EN 1092-1 (DIN 2501 / DIN 2512N <sup>1)</sup>) / PN 40: 1.4404/316L/316**

 Surface roughness (flange): EN 1092-1 Form B1 (DIN 2526 Form C), Ra 6.3 to 12.5  $\mu\text{m}$ 

DN	di	B	G	L	LK	N	P	S	T	U	V
15	13.9	276.5	95	245	65	4 × Ø14	132.5	16	112.5	17.3	116.5
25	24.3	276.5	115	245	85	4 × Ø14	132.5	18	112.5	28.5	116.5
40	38.1	273.5	150	320	110	4 × Ø18	200	18	120	43.1	113.5
50	49.2	278.5	165	400	125	4 × Ø18	250	20	150	54.5	118.5
80	73.7	291	200	640	160	8 × Ø18	400	24	240	82.5	131
100	97	303	235	800	190	8 × Ø22	500.5	24	299.5	107.1	143

<sup>1)</sup> Flange with groove to EN 1092-1 Form D (DIN 2512N) available  
All dimensions in [mm]

**Flange JIS B2220/ 10K / Sched 40: 1.4404/316L/316**

 Surface roughness (flange): Ra 3.2 to 6.3  $\mu\text{m}$ 

DN	di	B	G	L	LK	N	P	S	T	U	V
50	49.2	278.5	155	400	120	4 × Ø19	250.0	17.5	150.0	52.7	118.5
80	73.7	291.0	185	640	150	8 × Ø19	400.0	20	240.0	78.1	131.0
100	97.0	303.0	210	800	175	8 × Ø19	500.5	20	299.5	102.3	143.0

All dimensions in [mm]



**Flange JIS B2220/ 10K / Sched 80: 1.4404/316L/316**

Surface roughness (flange): Ra 3.2 to 6.3 µm

DN	di	B	G	L	LK	N	P	S	T	U	V
50	49.2	278.5	155	400	120	4 × Ø19	250.0	17.5	150.0	49.2	118.5
80	73.7	291.0	185	640	150	8 × Ø19	400.0	20	240.0	73.7	131.0
100	97.0	303.0	210	800	175	8 × Ø19	500.5	20	299.5	97.0	143.0

All dimensions in [mm]

**Flange JIS B2220/ 20K / Sched 40: 1.4404/316L/316**

Surface roughness (flange): Ra 3.2 to 6.3 µm

DN	di	B	G	L	LK	N	P	S	T	U	V
15	13.9	276.5	95	245	70	4 × Ø15	132.5	15	112.5	16.1	116.5
25	24.3	276.5	125	245	90	4 × Ø19	132.5	17	112.5	27.2	116.5
40	38.1	273.5	140	320	105	4 × Ø19	200	19	120	41.2	113.5
50	49.2	278.5	155	400	120	8 × Ø19	250	20	150	52.7	118.5
80	73.7	291.0	200	640	160	8 × Ø23	400	22	240	78.1	131.0
100	97	303.0	225	800	185	8 × Ø23	500.5	24	299.5	102.3	143.0

All dimensions in [mm]

**Flange JIS B2220/ 20K / Sched 80: 1.4404/316L/316**

Surface roughness (flange): Ra 3.2 to 6.3 µm

DN	di	B	G	L	LK	N	P	S	T	U	V
15	13.9	276.5	95	245	70	4 × Ø15	132.5	15	112.5	13.9	116.5
25	24.3	276.5	125	245	90	4 × Ø19	132.5	17	112.5	24.3	116.5
40	38.1	273.5	140	320	105	4 × Ø19	200	19	120	38.1	113.5
50	49.2	278.5	155	400	120	8 × Ø19	250	20	150	49.2	118.5
80	73.7	291.0	200	640	160	8 × Ø23	400	22	240	73.7	131.0
100	97	303.0	225	800	185	8 × Ø23	500.5	24	299.5	97	143.0

All dimensions in [mm]

t-mass 65F: Flange connections ANSI

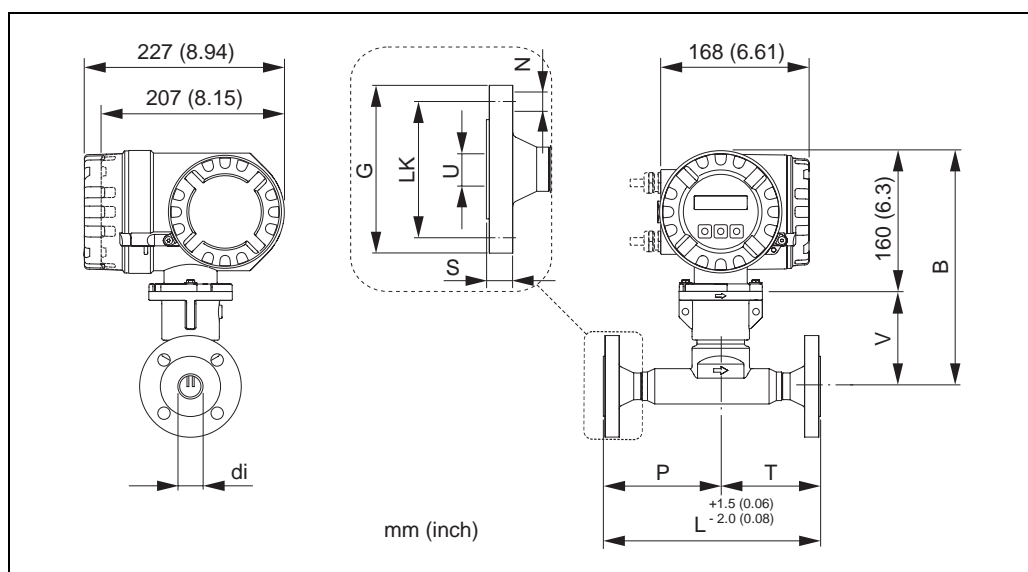

a0005162

**Flange ANSI B16.5 / CI 150 / Sched 40: 1.4404/316L/316**  
 Surface roughness (flange): N9 / 250 µinch

DN	di	B	G	L	LK	N	P	S	T	U	V	
15	½"	13.9	276.4	88.9	245	60.5	4 × Ø 15.7	132.5	11.2	112.5	15.7	112
25	1"	24.3	276.4	108.0	245	79.2	4 × Ø 15.7	132.5	14.2	112.5	26.7	112
40	1 ½"	38.1	273.6	127.0	320	98.6	4 × Ø 15.7	200	17.5	120	40.9	109
50	2"	49.2	278.4	152.4	400	120.7	4 × Ø 19.1	250	19.1	150	52.6	114
80	3"	73.7	291.1	190.5	640	152.4	4 × Ø 19.1	400	23.9	240	78.0	127
100	4"	97	303.0	228.6	800	190.5	8 × Ø 19.1	500.5	24.5	299.5	102.4	139

All dimensions in [mm]. US units see → 31.

**Flange ANSI B16.5 / CI 150 / Sched 80: 1.4404/316L/316**  
 Surface roughness (flange): N9 / 250 µinch

DN	di	B	G	L	LK	N	P	S	T	U	V	
15	½"	13.9	276.4	88.9	245	60.5	4 × Ø 15.7	132.5	11.2	112.5	13.9	112
25	1"	24.3	276.4	108.0	245	79.2	4 × Ø 15.7	132.5	14.2	112.5	24.3	112
40	1 ½"	38.1	273.6	127.0	320	98.6	4 × Ø 15.7	200	17.5	120	38.1	109
50	2"	49.2	278.4	152.4	400	120.7	4 × Ø 19.1	250	19.1	150	49.2	114
80	3"	73.7	291.1	190.5	640	152.4	4 × Ø 19.1	400	23.9	240	73.7	127
100	4"	97	303.0	228.6	800	190.5	8 × Ø 19.1	500.5	24.5	299.5	97.0	139

All dimensions in [mm]. US units see → 31.

<b>Flange ANSI B16.5 / CI 300 / Sched 40: 1.4404/316L/316</b>												
Surface roughness (flange): N9 / 250 µinch												
DN	di	B	G	L	LK	N	P	S	T	U	V	
15	½"	13.9	276.4	95.2	245	66.5	4 × Ø 15.7	132.5	14.2	112.5	15.7	112
25	1"	24.3	276.4	124.0	245	88.9	4 × Ø 19.1	132.5	17.5	112.5	26.7	112
40	1 ½"	38.1	273.6	155.4	320	114.3	4 × Ø 22.4	200	20.6	120	40.9	109
50	2"	49.2	278.4	165.1	400	127.0	8 × Ø 19.1	250	22.4	150	52.6	114
80	3"	73.7	291.1	209.6	640	168.1	8 × Ø 22.4	400	28.4	240	78.0	127
100	4"	97	303.0	254.0	800	200.2	8 × Ø 22.4	500.5	31.8	299.5	102.4	139
All dimensions in [mm]. US units see → 32.												

<b>Flange ANSI B16.5 / CI 300 / Sched 80: 1.4404/316L/316</b>												
Surface roughness (flange): N9 / 250 µinch												
DN	di	B	G	L	LK	N	P	S	T	U	V	
15	½"	13.9	276.4	95.2	245	66.5	4 × Ø 15.7	132.5	14.2	112.5	13.9	112
25	1"	24.3	276.4	124.0	245	88.9	4 × Ø 19.1	132.5	17.5	112.5	24.3	112
40	1 ½"	38.1	273.6	155.4	320	114.3	4 × Ø 22.4	200	20.6	120	38.1	109
50	2"	49.2	278.4	165.1	400	127.0	8 × Ø 19.1	250	22.4	150	49.2	114
80	3"	73.7	291.1	209.6	640	168.1	8 × Ø 22.4	400	28.4	240	73.7	127
100	4"	97	303.0	254.0	800	200.2	8 × Ø 22.4	500.5	31.8	299.5	97.0	139
All dimensions in [mm]. US units see → 32.												

t-mass 65I: Compact insertion version

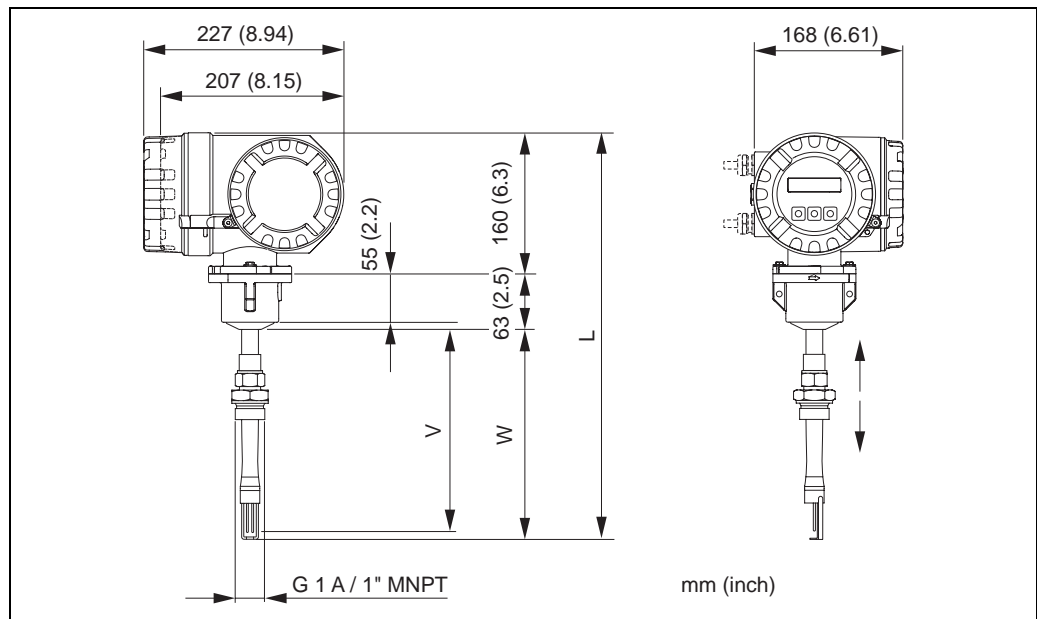

a0005163

t-mass 65I: Remote sensor housing insertion version

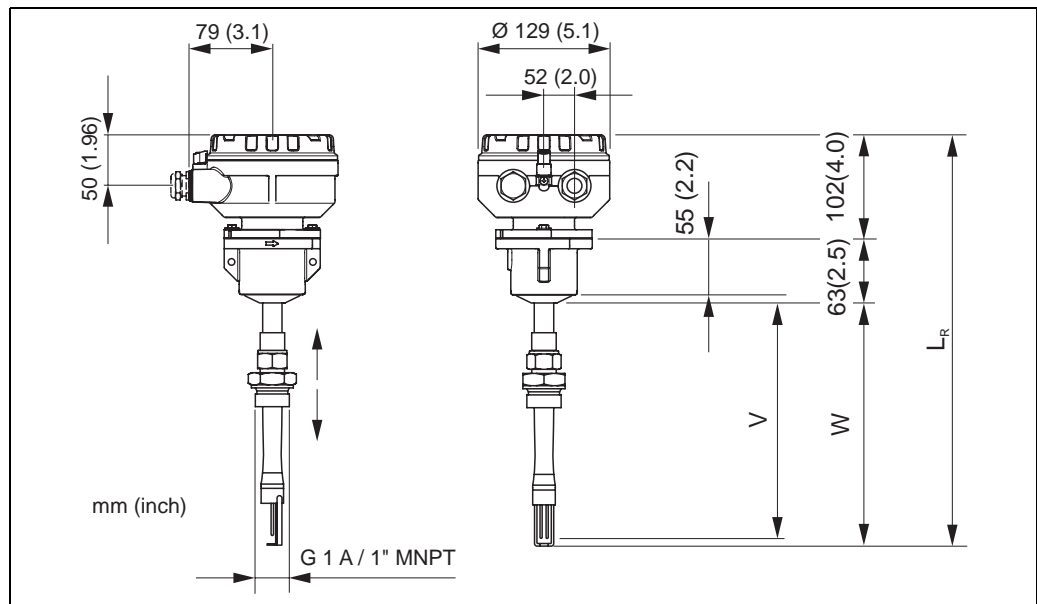

a0005159

Length t-mass 65I	V	W	L	L <sub>R</sub>
235	235.1	252.6	475.6	417.6
335	335.1	352.6	575.6	517.6
435	435.1	452.6	675.6	617.6
608	608.1	625.6	848.6	790.6
All dimensions in [mm]				

Flow conditioner according to EN (DIN) / JIS / ANSI

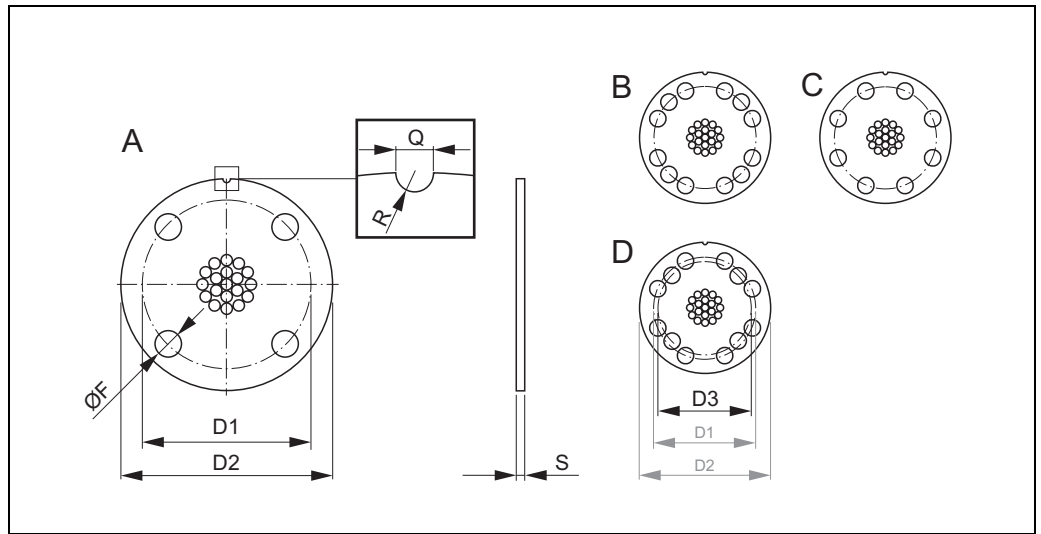

a0005100

DN	Type	D1	D2	F	Q	R	EN (DIN)			
							PN 16		PN 40	
							S	Weight	S	Weight
25	A	83	105	13	5	2.5	-	-	4.5	0.3
40	A	108	135	17	5	2.5	-	-	7.0	0.7
50	A	123	150	17	5	2.5	-	-	8.5	1.0
80	C	158	185	17	5	2.5	-	-	13.0	2.3
100	C	187	220	22	5	2.5	17.0	4.1	17.0	4.1

All dimensions in [mm], [kg]

DN	Type	D1	D2	F	Q	R	JIS 10K/20K			
							Sched 40		Sched 80	
							S	Weight	S	Weight
25	A	87	115	17	5	2.5	4.5	0.4	4.0	0.4
40	A	102	130	17	5	2.5	6.5	0.7	6.0	0.7
50	B	117	145	17	5	2.5	8.5	1.2	8.0	1.1
80	C	157	188	21	5	2.5	12.5	3.0	12.0	2.8
100	C	182	214	21	5	2.5	16.5	5.1	15.5	4.8

All dimensions in [mm], [kg]

DN	Type	D1	D2	D3	F	Q	R	ANSI Cl. 150/300				
								Sched 40		Sched 80		
								S	Weight	S	Weight	
25	1"	A	85.3	110	-	17.0	5	2.5	4.5	0.4	4.5	0.4
40	1 1/2"	A	109.5	140	-	21.5	5	2.5	6.5	0.9	6.5	0.9
50	2"	D	122	150	115.5	19.0	5	2.5	8.5	1.3	8.5	1.3
80	3"	D	163	195	144.0	22.0	5	2.5	12.5	3.2	12.5	3.2
100	4"	C	179	228	-	20.5	5	2.5	16.5	5.3	16.5	5.3

All dimensions in [mm], [kg], US units see → 34

Hot tap

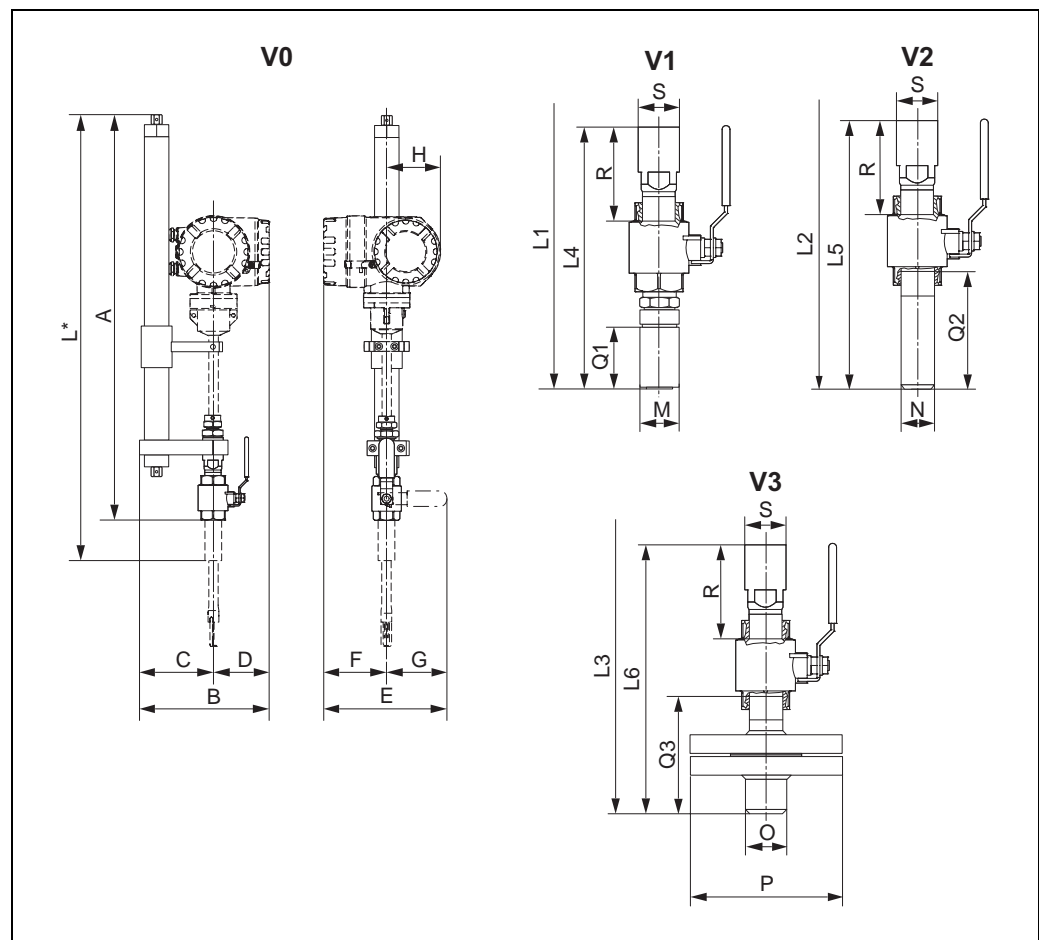

A0013815

$L^*$  = Dependent on the used version (V1, V2, V3). See dimensions L1, L2, L3.

A	B	C	D	E	F	G	H
824 ±2	262	150	112	254	129	125	110
All dimensions in [mm]							

L1	L2	L3	L4	L5	L6	M	N
	909.5			252.5		45	33.4
All dimensions in [mm]							

O	P	Q1	Q2	Q3	S	R
33.4	123.9	60	123	123	42.2	96
All dimensions in [mm]						

Weight

V0*	V1	V2	V3
8.4	2.8	2.4	4.9
* without V1, V2 or V3 Weight in [kg]			

**Process connections in US units**

*t-mass 65F: Flange connections ANSI*

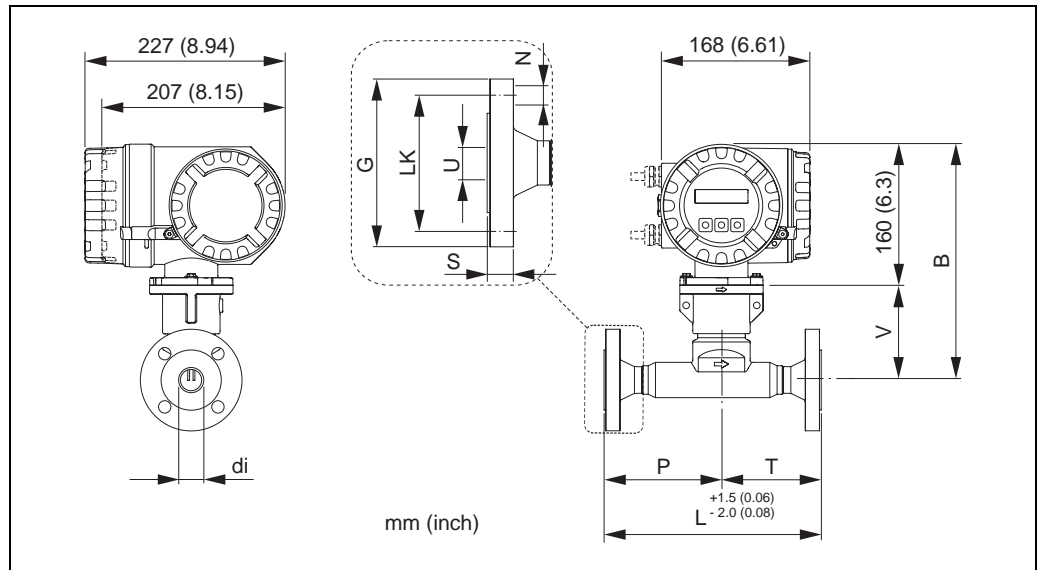

a0005162

**Flange ANSI B16.5 / Cl 150 / Sched 40: 1.4404/316L/316**

Surface roughness (flange): N9 / 250 µinch

DN	di	B	G	L	LK	N	P	S	T	U	V
½"	0.55	10.9	3.50	9.65	2.38	4 × 0.62	5.22	0.44	4.43	0.62	4.41
1"	0.96	10.9	4.25	9.65	3.12	4 × 0.62	5.22	0.56	4.43	1.05	4.41
1 ½"	1.50	10.8	5.00	12.60	3.88	4 × 0.62	7.87	0.69	4.72	1.61	4.29
2"	1.94	11.0	6.00	15.75	4.75	4 × 0.75	9.84	0.75	5.91	2.07	4.49
3"	2.90	11.5	7.50	25.20	6.00	4 × 0.75	15.75	0.94	9.45	3.07	5.00
4"	3.82	11.9	9.00	31.50	7.50	8 × 0.75	19.70	0.96	11.79	4.03	5.47

All dimensions in [inch]

**Flange ANSI B16.5 / Cl 150 / Sched 80: 1.4404/316L/316**

Surface roughness (flange): N9 / 250 µinch

DN	di	B	G	L	LK	N	P	S	T	U	V
½"	0.55	10.9	3.50	9.65	2.38	4 × 0.62	5.22	0.44	4.43	0.55	4.41
1"	0.96	10.9	4.25	9.65	3.12	4 × 0.62	5.22	0.56	4.43	0.96	4.41
1 ½"	1.50	10.8	5.00	12.6	3.88	4 × 0.62	7.87	0.69	4.72	1.50	4.29
2"	1.94	11.0	6.00	15.7	4.75	4 × 0.75	9.84	0.75	5.91	1.94	4.49
3"	2.90	11.5	7.50	25.2	6.00	4 × 0.75	15.75	0.94	9.45	2.90	5.00
4"	3.82	11.9	9.00	31.5	7.50	8 × 0.75	19.70	0.96	11.79	3.82	5.47

All dimensions in [inch]

<b>Flange ANSI B16.5 / CI 300 / Sched 40: 1.4404/316L/316</b>											
Surface roughness (flange): N9 / 250 µinch											
DN	di	B	G	L	LK	N	P	S	T	U	V
½"	0.55	10.9	3.75	9.65	2.62	4 × 0.62	5.22	0.56	4.43	0.62	4.41
1"	0.96	10.9	4.88	9.65	3.50	4 × 0.75	5.22	0.69	4.43	1.05	4.41
1 ½"	1.50	10.8	6.12	12.6	4.50	4 × 0.88	7.87	0.81	4.72	1.61	4.29
2"	1.94	11.0	6.50	15.7	5.00	8 × 0.75	9.84	0.88	5.91	2.07	4.49
3"	2.90	11.5	8.25	25.2	6.62	8 × 0.88	15.75	1.12	9.45	3.07	5.00
4"	3.82	11.9	10.00	31.5	7.88	8 × 0.88	19.70	1.25	11.79	4.03	5.47
All dimensions in [inch]											

<b>Flange ANSI B16.5 / CI 300 / Sched 80: 1.4404/316L/316</b>											
Surface roughness (flange): N9 / 250 µinch											
DN	di	B	G	L	LK	N	P	S	T	U	V
½"	0.55	10.9	3.75	9.65	2.62	4 × 0.62	5.22	0.56	4.43	0.55	4.41
1"	0.96	10.9	4.88	9.65	3.50	4 × 0.75	5.22	0.69	4.43	0.96	4.41
1 ½"	1.50	10.8	6.12	12.6	4.50	4 × 0.88	7.87	0.81	4.72	1.50	4.29
2"	1.94	11.0	6.50	15.7	5.00	8 × 0.75	9.84	0.88	5.91	1.94	4.49
3"	2.90	11.5	8.25	25.2	6.62	8 × 0.88	15.75	1.12	9.45	2.90	5.00
4"	3.82	11.9	10.00	31.5	7.88	8 × 0.88	19.70	1.25	11.79	3.82	5.47
All dimensions in [inch]											



*t-mass 65I: Compact insertion version*

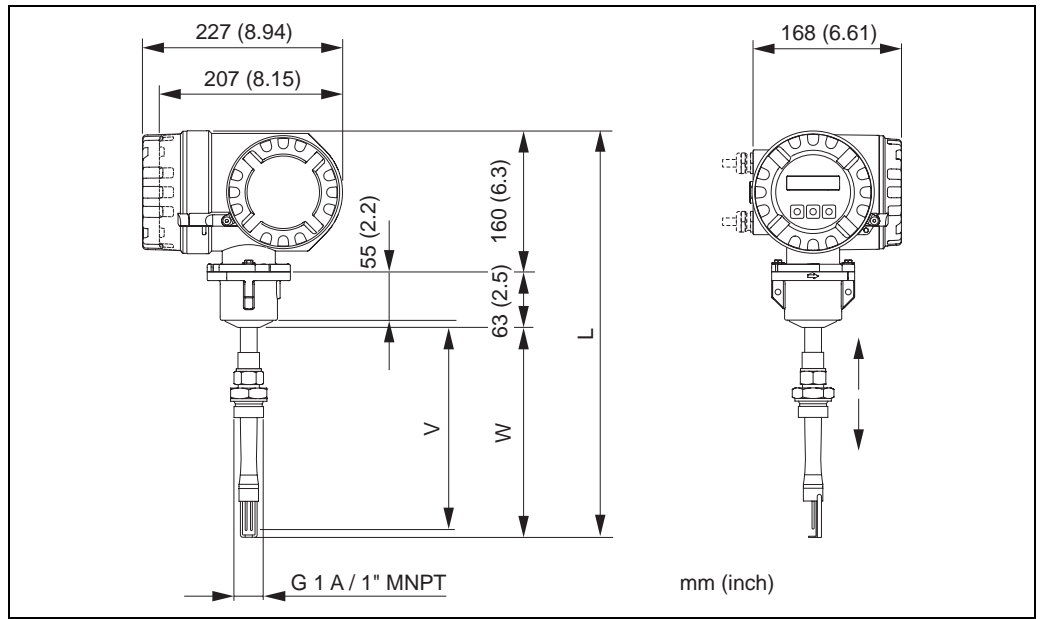

*t-mass 65I: Remote sensor housing insertion version*

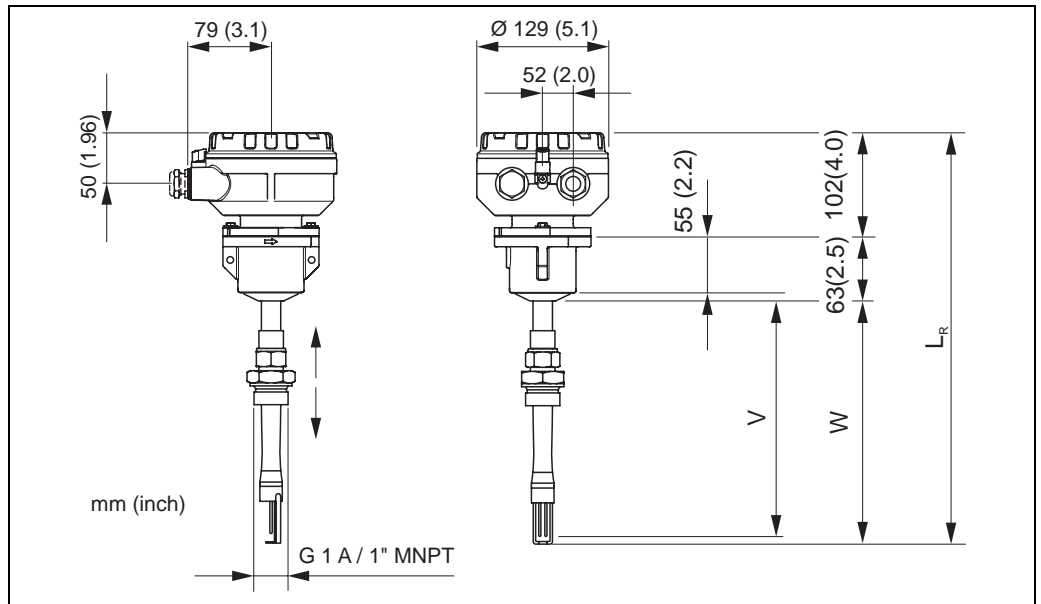

Length t-mass 65I	V	W	L	L <sub>R</sub>
9"	9.26	9.94	18.72	16.44
13"	13.19	13.88	22.66	20.38
17"	17.13	17.82	26.60	24.31
24"	23.94	24.63	33.41	31.13

All dimensions in [inch]

Flow conditioner according to ANSI

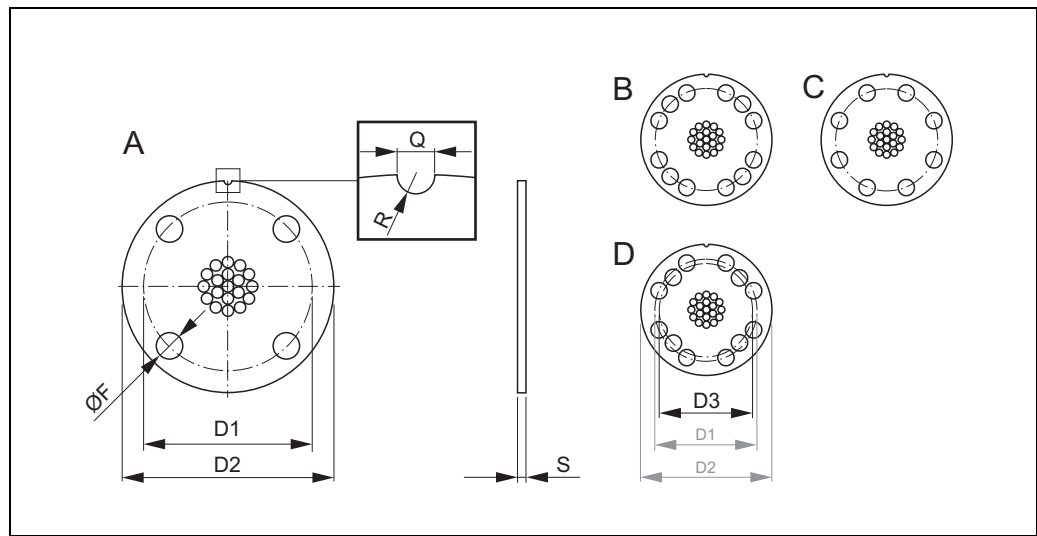

a0005166

DN]	Typ	D1	D2	D3	F	Q	R	ANSI Cl. 150/300			
								Sched 40		Sched 80	
								S	Weight	S	Weight
1"	A	3.36	4.3	–	0.67	0.2	0.1	0.18	0.8	0.18	0.8
1 ½"	A	4.31	5.5	–	0.85	0.2	0.1	0.26	1.9	0.26	1.9
2"	D	4.80	5.9	4.55	0.7	0.2	0.1	0.33	2.8	0.33	2.8
3"	D	6.42	7.7	5.67	0.9	0.2	0.1	0.49	7.0	0.49	7.0
4"	C	7.05	8.0	–	0.8	0.2	0.1	0.65	11.7	0.65	11.7

All dimensions in [inch], [lbs]

Hot tap

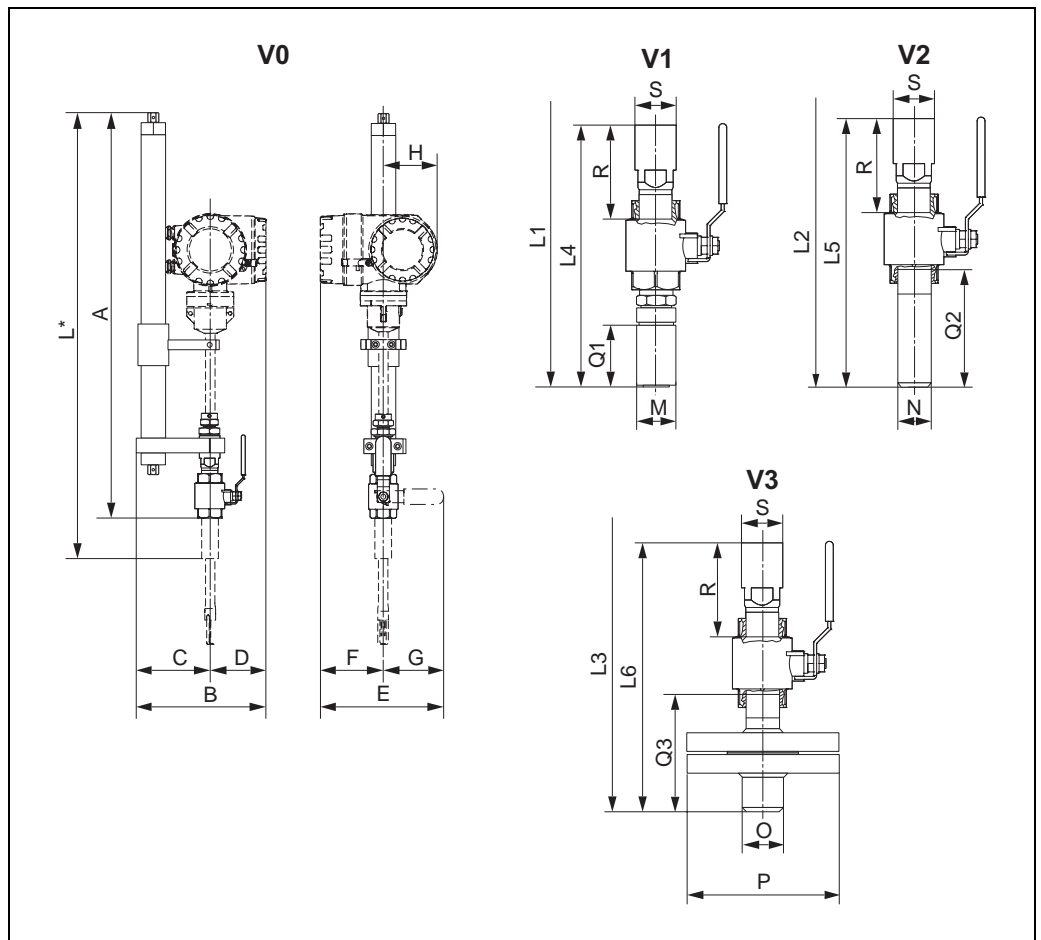

A0013815

L\* = Dependent on the used version (V1, V2, V3). See dimensions L1, L2, L3.

A	B	C	D	E	F	G	H
32.44	10.31	5.91	4.41	10.00	5.08	4.92	4.33
All dimensions in [inch]							





L1	L2	L3	L4	L5	L6	M	N
35.81		9.94			1.77	1.31	
All dimensions in [inch]							

O	P	Q1	Q2	Q3	S	R
1.31	4.88	2.36	4.84	4.84	1.66	3.78
All dimensions in [inch]						

Weight

V0*	V1	V2	V3
18.5	6.1	5.2	10.8
* without V1, V2 or V3 Weight in [lbs]			

**Weight**

- Compact version: see table below
- Remote version
  - Sensor: see table below
  - Wall-mount housing: 5 kg (11 lbs)
- Flow conditioner →  29, →  34
- Hot tap →  30, →  35

**Weight (SI units)**

t-mass F* / DN	15	25	40	50	80	100
Compact version	7.5	8.0	12.5	12.5	18.7	27.9
Remote version (sensor only)	5.5	6.0	10.5	10.5	16.7	25.9

t-mass I / sensor length [mm]	235	335	435	608
Compact version	6.4	6.6	7.0	7.4
Remote version (sensor only)	4.4	4.6	5.0	5.4

Weight dimensions in [kg].

\* For flanged versions, all values (weight) refer to devices with EN/DIN PN 40 flanges.

**Weight (US units)**

t-mass F* / DN [inch]	½"	1"	1½"	2"	3"	4"
Compact version	16.5	17.6	27.5	27.5	41.2	61.5
Remote version (sensor only)	12.1	13.2	23.1	23.1	36.7	57.1

t-mass I / sensor length [inch]	9.25"	13.2"	17.1"	24.0"
Compact version	14.1	14.5	15.4	16.3
Remote version (sensor only)	9.7	10.1	11.0	11.9

Weight dimensions in [lbs].

\* For flanged versions, all values (weight) refer to devices with Cl 150 flanges.

**Materials****Transmitter housing**

- Compact housing: powder coated die-cast aluminum
- Wall-mount housing: powder coated die-cast aluminum
- Remote field housing: powder coated die-cast aluminum

**Connection housing, sensor (remote version)**

Powder coated die-cast aluminum

**t-mass F sensor**

Sensor body:

- DN 15 to 25 (DN ½" to DN 1"): stainless steel cast CF3M-A351
- DN 40 to 100 (DN 1 ½" to DN 4"): 1.4404 to EN10216-5 and 316/316L to A312

Flanges (process connections):

According to EN 1092-1 (DIN 2501/DIN 2512N) / ANSI B16.5 / JIS B2220

→ stainless steel 1.4404 to EN 10222-5 and 316L/316 to A182

Transducer body:

- 1.4404 to EN10272 and 316L to A479
- Alloy C22 (2.4602) and UNS N06022 to B574

Transducer elements:

- 1.4404 to EN10217-7 and 316L to A249 or
- 1.4404 to EN 10216-5 and 316L to A213
- Alloy C22 (2.4602) and UNS N06022 to B626

Bushing:

PEEK GF30, PVDF

O-ring seals:

EPDM, Kalrez 6375, Viton FKM

**t-mass I sensor**

Insertion tube:

Sensor length 235 (9"), 335 (13"), 435 (17"), 608 (24")  
 1.4404 to EN 10216-5 and 316/316L to A312

Transducer body:

- 1.4404 to EN10272 and 316L to A479
- Alloy C22 (2.4602) and UNS N06022 to B574

Transducer elements:

- 1.4404 to EN10217-7 and 316L to A249 or
- 1.4404 to EN 10216-5 and 316L to A213
- Alloy C22 (2.4602) and UNS N06022 to B626

Protection guard:

1.4404 to EN 10088-1 and EN 10088-2 + 2B and 316L to A666

Compression fitting:

1.4404 to EN 10272 and 316/316L to A479

Ferrules:

PEEK 450G, PVDF

Bonded seals:

EPDM, Kalrez 6375, Nitrile and 316/316L (outer ring)

**Hot tap**

Lower tube section:

1.4404 to EN 10272 and 316/316L to A479

Upper tube section:

1.4404 to EN 10216-5 and 316/316L to A312

Ball valve:

CF3M and CF8M

Seal:

PTFE

**Material load curves**

**Flange connections to EN 1092-1 (DIN 2501/DIN 2512N)**

Flange material: stainless Steel 1.4404/316L/316

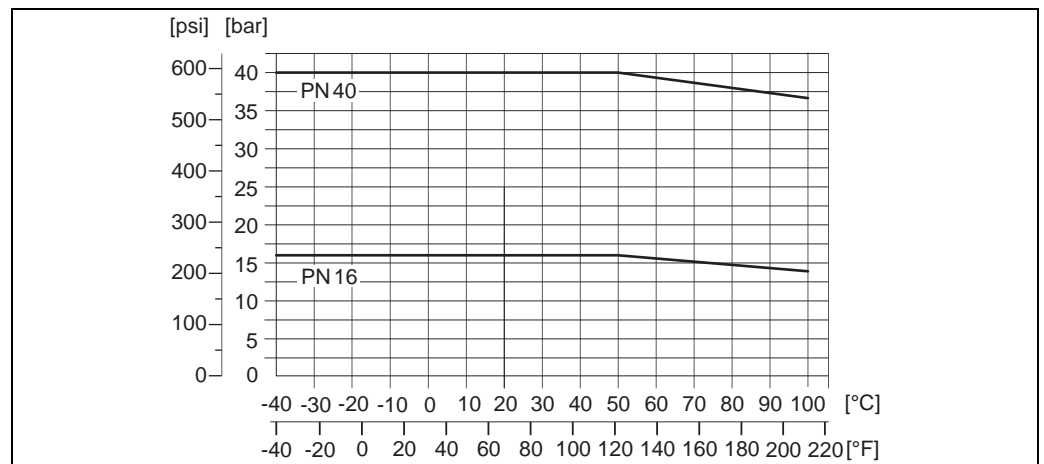

80005240

**Flange connections to JIS B2220**

Flange material: stainless Steel 1.4404/316L/316

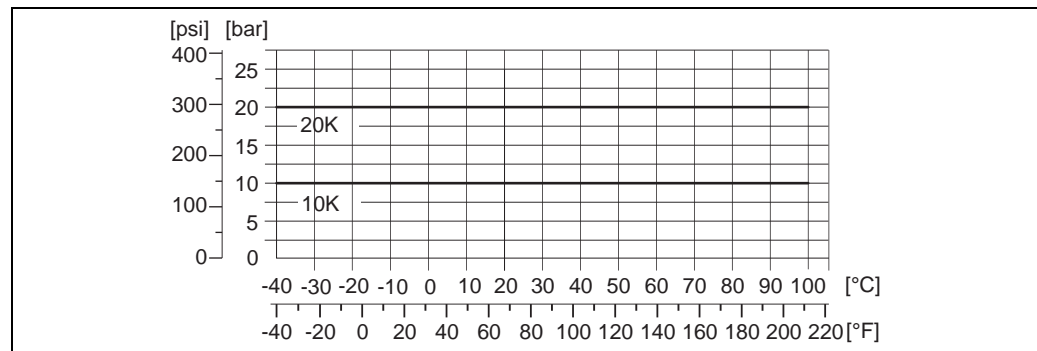

A0005241

**Flange connections to ANSI B16.5**

Flange material: stainless Steel 1.4404/316L/316

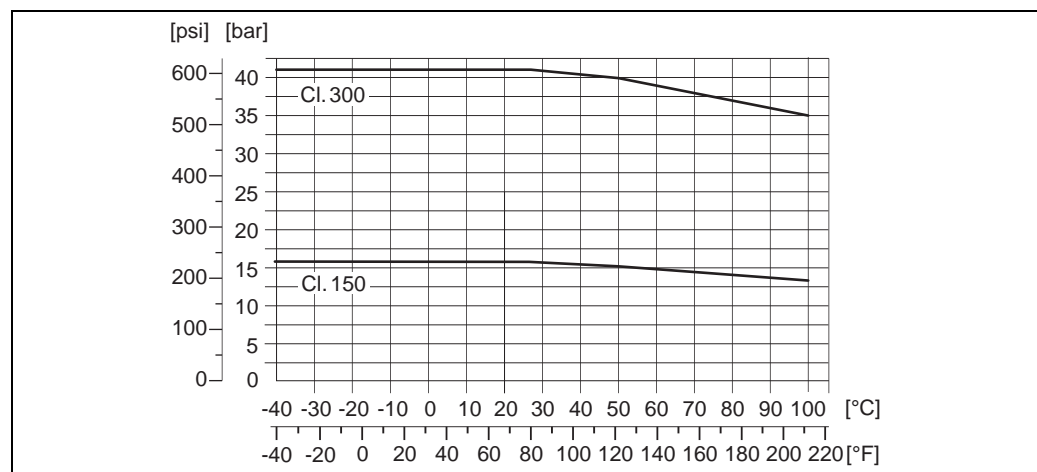

A0013825

**Process connections**

For both the flanged and insertion meters it is possible to have wetted parts degreased for oxygen service. Contact your Endress+Hauser service representative for further details.

t-mass F:

Flanges according EN 1092-1, JIS B2220 and ANSI B16.5

t-mass I:



G 1A or 1" MNPT thread

## Human interface

<b>Display elements</b>	<ul style="list-style-type: none"> <li>■ Liquid crystal display: illuminated, two lines with 16 characters per line</li> <li>■ Selectable display of different measured values and status variables</li> <li>■ At ambient temperatures below <math>-20\text{ °C}</math> (<math>-4\text{ °F}</math>) the readability of the display may be impaired.</li> </ul>
<b>Operating elements</b>	<ul style="list-style-type: none"> <li>■ Local operation with push buttons (–, +, E)</li> <li>■ Quick Setup menus for straight forward commissioning</li> </ul>
<b>Languages</b>	English, German, French, Spanish, Italian, Dutch, Norwegian, Finnish, Swedish, Portuguese, Polish, Czech
<b>Remote operation</b>	Operation via HART, PROFIBUS PA/DP, FOUNDATION Fieldbus, MODBUS RS485

## Certificates and approvals

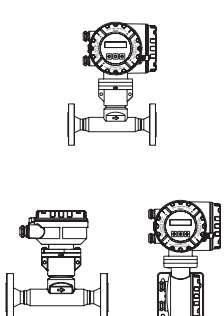
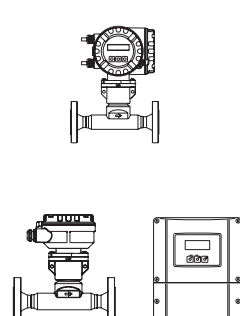
<b>CE mark</b>	The measuring system is in conformity with the statutory requirements of the EC Directives. Endress+Hauser confirms successful testing of the device by affixing to it the CE mark.
<b>C-Tick mark</b>	The measuring system meets the EMC requirements of the Australian Communications and Media Authority (ACMA).
<b>Ex approval</b>	Information about currently available Ex versions (ATEX, FM, CSA) can be supplied by your Endress+Hauser representative on request. All explosion protection data are given in a separate documentation which is available upon request.

Hazardous area		Safe area
II2GD / Cl. 1 Div. 1	II3G / Cl. 1 Div. 2	
		

Example of t-mass devices in the hazardous area (Example t-mass 65F)

a0005128-en

### FOUNDATION Fieldbus certification

The flowmeter has passed all the test procedures implemented and has been certified and registered by the Fieldbus Foundation. The flowmeter thus meets all the requirements of the specifications listed below:

- Certified to FOUNDATION Fieldbus specification
- The flowmeter meets all the specifications of the FOUNDATION Fieldbus-H1.
- Interoperability Test Kit (ITK), revision status 5.01 (Certification on request)
- The device can also be operated in conjunction with other-make certified devices.
- Physical Layer Conformance Test of the Fieldbus Foundation

<b>PROFIBUS DP/PA certification</b>	<p>The flow device has successfully passed all the test procedures carried out and is certified and registered by the PNO (PROFIBUS User Organization). The device thus meets all the requirements of the following specifications:</p> <ul style="list-style-type: none"> <li>■ Certified to PROFIBUS Profile Version 3.0 (device certification number: on request)</li> <li>■ The device can also be operated with certified devices of other manufacturers (interoperability)</li> </ul>
<b>MODBUS certification</b>	<p>The measuring device meets all the requirements of the MODBUS/TCP conformity and integration test and has the "MODBUS/TCP Conformance Test Policy, Version 2.0". The measuring device has successfully passed all the test procedures carried out and is certified by the "MODBUS/TCP Conformance Test Laboratory" of the University of Michigan.</p>
<b>Pressure measuring device approval</b>	<p>The measuring devices can be ordered with or without PED (Pressure Equipment Directive). If a device with PED is required, this must be ordered explicitly. For devices with nominal diameters less than or equal to DN 25 (1"), this is neither possible nor necessary.</p> <ul style="list-style-type: none"> <li>■ With the identification PED/G1/III on the sensor nameplate, Endress+Hauser confirms conformity with the "Basic safety requirements" of Appendix I of the Pressure Equipment Directive 97/23/EC.</li> <li>■ Devices with this identification (with PED) are suitable for the following types of fluid: <ul style="list-style-type: none"> <li>– Fluids of Group 1 and 2 with a steam pressure of greater or less than 0.5 bar (7.3 psi)</li> <li>– Unstable gases</li> </ul> </li> <li>■ Devices without this identification (without PED) are designed and manufactured according to good engineering practice. They correspond to the requirements of Art. 3, Section 3 of the Pressure Equipment Directive 97/23/EC. Their application is illustrated in Diagrams 6 to 9 in Appendix II of the Pressure Equipment Directive 97/23/EC.</li> </ul>
<b>Oxygen service</b>	<p>We certify that the wetted parts of the flow sensor have been degreased in accordance with British Oxygen Company (BOC) specification 0000-N-S-430-00-01 and BS IEC 60877:1999. After final degreasing there shall be less than 100 milligram/m<sup>2</sup> (0.01 milligram/cm<sup>2</sup>) of oil/grease contamination on the degreased surface of the component.</p>
<b>Other standards and guidelines</b>	<p>BS IEC 60877:1999 Procedures for ensuring the cleanliness of industrial-process measurement and control equipment in oxygen service.</p> <p>EN 60529 Degrees of protection by housing (IP code)</p> <p>EN 61010-1 Protection Measures for Electrical Equipment for Measurement, Control, Regulation and Laboratory Procedures.</p> <p>EN 91/155/EEC Safety Data Sheets Directive.</p> <p>IEC/EN 61326 "Emission in accordance with requirements for Class A". Electromagnetic compatibility (EMC- requirements).</p> <p>ISO 14511 Measurement of fluid flow in closed conduits - Thermal mass flowmeters.</p> <p>ISO/IEC 17025 General requirements for the competence of testing and calibration laboratories.</p> <p>NAMUR NE 21 Electromagnetic compatibility (EMC) of industrial process and laboratory control equipment.</p> <p>NAMUR NE 43 Standardization of the signal level for the breakdown information of digital transmitters with analogue output signal.</p> <p>NAMUR NE 53 Software of field devices and signal-processing devices with digital electronics</p>



## Ordering information

The Endress +Hauser service organization can provide detailed ordering information and information on the order codes on request.

To ensure each meter is programmed to individual requirements, the following information is essential:

- Gas type if not air (composition if more than one gas in % Mole)
- Gas pressure
- Gas temperature
- Line size - internal diameter in metric or US units
- 20 mA range required
- Flow engineering units (kg/h, lb/h etc.)

## Accessories

The Endress +Hauser service organization can provide detailed information on request.

### Device-specific accessories

Accessory	Description	Order code
Mounting boss	Mounting boss for the t-mass insertion version	DK6MB - *
Cable remote version	Connecting cable for the remote version	DK6CA - *

### Measuring principle-specific accessories

Accessory	Description	Order code
Mounting set for transmitter	Mounting set for remote version. Suitable for: <ul style="list-style-type: none"> <li>- Wall mounting</li> <li>- Pipe mounting</li> <li>- Installation in control panel</li> </ul> Mounting set for aluminum field housing: Suitable for pipe mounting (3/4" to 3")	DK6WM - *
Hot tap	Mounting set with ball valve and safety chain. Insertion or extraction of sensor under process pressure (max. 4 bar / 58 psi). Mounting set with ball valve and spindle retractor. Insertion or extraction of sensor under process pressure (max. 16 bar (235 psi)).	Please refer to the product page of the Endress+Hauser Internet page: <a href="http://www.endress.com">www.endress.com</a>
Flow conditioners	<ul style="list-style-type: none"> <li>■ t-mass F sensor (DN25 to 100, 1" to 4")</li> <li>■ t-mass I sensor (DN80 to 300, 3" to 12")</li> </ul>	DK6ST-*** DK7ST-***
Graphic data manager Memograph M	The graphic data manager Memograph M provides information on all the relevant process variables. Measured values are recorded correctly, limit values are monitored and measuring points analyzed. The data are stored in the 256 MB internal memory and also on an SD card or USB stick. Memograph M boasts a modular design, intuitive operation and a comprehensive security concept. The ReadWin® 2000 PC software is part of the standard package and is used for configuring, visualizing and archiving the data captured.	RSG40 - *****

**Service-specific accessories**

Accessory	Description	Order code
Applicator	<p>Software for selecting and sizing Endress+Hauser measuring devices:</p> <ul style="list-style-type: none"> <li>■ Calculation of all the necessary data for identifying the optimum flowmeter: e.g. nominal diameter, pressure loss, accuracy or process connections</li> <li>■ Graphic illustration of the calculation results</li> </ul> <p>Administration, documentation and access to all project-related data and parameters over the entire life cycle of a project.</p> <p>Applicator is available:</p> <ul style="list-style-type: none"> <li>■ Via the Internet: <a href="https://wapps.endress.com/applicator">https://wapps.endress.com/applicator</a></li> <li>■ On CD-ROM for local PC installation.</li> </ul>	DKA80 - *
Fieldcheck	<p>Tester/simulator for testing flowmeters in the field.</p> <p>When used in conjunction with the "FieldCare" software package, test results can be imported into a database, printed and used for official certification.</p> <p>Contact your Endress+Hauser representative for more information.</p>	50098801
FieldCare	<p>FieldCare is Endress+Hauser's FDT based Plant Asset Management Tool. It can configure all intelligent field devices in your plant and supports you in managing them. By using status information, it also provides a simple but effective means of checking their health.</p>	<p>Please refer to the product page of the Endress+Hauser Internet page: <a href="http://www.endress.com">www.endress.com</a></p>
FXA193	<p>The FXA193 service interface connects the device to the PC for configuration via FieldCare.</p>	FXA193 - *

**Communication-specific accessories**

Accessory	Description	Order code
HART Communicator Field Xpert SFX 100	<p>Handheld terminal for remote configuration and for obtaining measured values via the 4 to 20 mA HART current output.</p> <p>Contact your Endress+Hauser representative for more information.</p>	SFX100 - *****

## Documentation

- Flow measuring technology (FA005D)
- Technical Information (TI069D/06)
- Operating Instructions HART (BA111D/06)
- Operating Instructions PROFIBUS DP (BA113D/06)
- Operating Instructions MODBUS (BA115D/06)
- Description of Device Functions HART (BA112D/06)
- Description of Device Functions PROFIBUS DP (BA114D/06)
- Description of Device Functions MODBUS (BA116D/06)
- Supplementary documentation on Ex-ratings: ATEX, FM, CSA, IECEx NEPSI

## Registered trademarks

KALREZ® and VITON®

Registered trademarks of E.I. Du Pont de Nemours & Co., Wilmington, USA

AMS™

Registered trademark of Emerson Process Management, St. Louis, USA

HART®

Registered trademark of HART Communication Foundation, Austin, USA

PROFIBUS®

Registered trademark of the PROFIBUS User Organisation, Karlsruhe, Germany

FOUNDATION™ Fieldbus

Registered trademark of the Fieldbus FOUNDATION, Austin, USA

MODBUS®

Registered trademark of the MODBUS Organisation

HistoROM™, S-DAT®, T-DAT™, F-CHIP®, FieldCare®, Field Xpert™, Fieldcheck®,  
Applicator®, t-mass®

Registered or registration-pending trademarks of Endress+Hauser Flowtec AG, Reinach, CH

---

## Instruments International

Endress+Hauser  
Instruments International AG  
Kaegenstrasse 2  
4153 Reinach  
Switzerland

Tel. +41 61 715 81 00  
Fax +41 61 715 25 00  
[www.endress.com](http://www.endress.com)  
[info@ii.endress.com](mailto:info@ii.endress.com)

**Endress+Hauser**   
People for Process Automation