

Operating Instructions

Cleanfit CUA451

Retractable process assembly

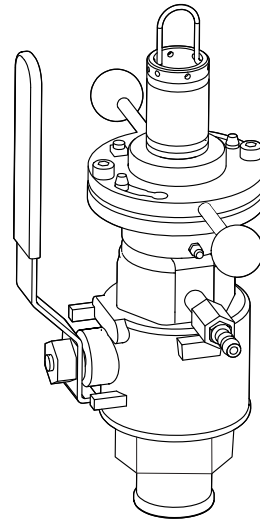





Table of contents







1	About this document	4	11.2	Process	40
1.1	Warnings	4	11.3	Mechanical construction	40
1.2	Symbols	4			
1.3	Symbols on the device	4	Index		42
2	Basic safety instructions	5			
2.1	Requirements for the personnel	5			
2.2	Designated use	5			
2.3	Workplace safety	5			
2.4	Operational safety	6			
3	Product description	7			
3.1	Product design	7			
4	Incoming acceptance and product identification	9			
4.1	Incoming acceptance	9			
4.2	Product identification	9			
4.3	Scope of delivery	10			
4.4	Certificates and approvals	10			
5	Installation	11			
5.1	Installation conditions	11			
5.2	Mounting the assembly	17			
5.3	Post-installation check	26			
6	Commissioning	27			
6.1	Preparatory steps	27			
7	Operation	28			
7.1	Adapting the device to the process conditions	28			
8	Maintenance	29			
8.1	Maintenance tasks	29			
9	Repair	34			
9.1	General information	34			
9.2	Spare parts	35			
9.3	Return	36			
9.4	Disposal	36			
10	Accessories	37			
10.1	Device-specific accessories	37			
10.2	Service-specific accessories	39			
11	Technical data	40			
11.1	Environment	40			

1 About this document

1.1 Warnings

Structure of information	Meaning
<p> DANGER</p> <p>Causes (/consequences) If necessary, Consequences of non-compliance (if applicable)</p> <ul style="list-style-type: none"> ▶ Corrective action 	<p>This symbol alerts you to a dangerous situation. Failure to avoid the dangerous situation will result in a fatal or serious injury.</p>
<p> WARNING</p> <p>Causes (/consequences) If necessary, Consequences of non-compliance (if applicable)</p> <ul style="list-style-type: none"> ▶ Corrective action 	<p>This symbol alerts you to a dangerous situation. Failure to avoid the dangerous situation can result in a fatal or serious injury.</p>
<p> CAUTION</p> <p>Causes (/consequences) If necessary, Consequences of non-compliance (if applicable)</p> <ul style="list-style-type: none"> ▶ Corrective action 	<p>This symbol alerts you to a dangerous situation. Failure to avoid this situation can result in minor or more serious injuries.</p>
<p>NOTICE</p> <p>Cause/situation If necessary, Consequences of non-compliance (if applicable)</p> <ul style="list-style-type: none"> ▶ Action/note 	<p>This symbol alerts you to situations which may result in damage to property.</p>

1.2 Symbols

Symbol	Meaning
	Additional information, tips
	Permitted or recommended
	Not permitted or not recommended
	Reference to device documentation
	Reference to page
	Reference to graphic
	Result of a step

1.3 Symbols on the device

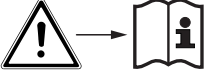
Symbol	Meaning
	Reference to device documentation

2 Basic safety instructions

2.1 Requirements for the personnel

- Installation, commissioning, operation and maintenance of the measuring system may be carried out only by specially trained technical personnel.
- The technical personnel must be authorized by the plant operator to carry out the specified activities.
- The electrical connection may be performed only by an electrical technician.
- The technical personnel must have read and understood these Operating Instructions and must follow the instructions contained therein.
- Faults at the measuring point may only be rectified by authorized and specially trained personnel.

 Repairs not described in the Operating Instructions provided must be carried out only directly at the manufacturer's site or by the service organization.

2.2 Designated use

The manually operated Cleanfit CUA451 retractable assembly is designed for the installation of turbidity sensors in vessels and pipelines.

Thanks to its design, it can be operated in pressurized systems.

The assembly is designed exclusively for use in liquid media.

Use of the device for any purpose other than that described, poses a threat to the safety of people and of the entire measuring system and is therefore not permitted.

The manufacturer is not liable for damage caused by improper or non-designated use.

2.3 Workplace safety

As the user, you are responsible for complying with the following safety conditions:

- Installation guidelines
- Local standards and regulations

Electromagnetic compatibility

- The product has been tested for electromagnetic compatibility in accordance with the applicable European standards for industrial applications.
- The electromagnetic compatibility indicated applies only to a product that has been connected in accordance with these Operating Instructions.

2.4 Operational safety

Before commissioning the entire measuring point:

1. Verify that all connections are correct.
2. Ensure that electrical cables and hose connections are undamaged.
3. Do not operate damaged products, and protect them against unintentional operation.
4. Label damaged products as defective.

During operation:

- ▶ If faults cannot be rectified:
products must be taken out of service and protected against unintentional operation.

CAUTION

Cleaning not switched off during calibration or maintenance activities

Risk of injury due to medium or cleaning agent!

- ▶ If a cleaning system is connected, switch it off before removing a sensor from the medium.
- ▶ If you wish to check the cleaning function and have therefore not switched off the cleaning system, wear protective clothing, goggles and gloves or take other appropriate measures.

3 Product description

3.1 Product design

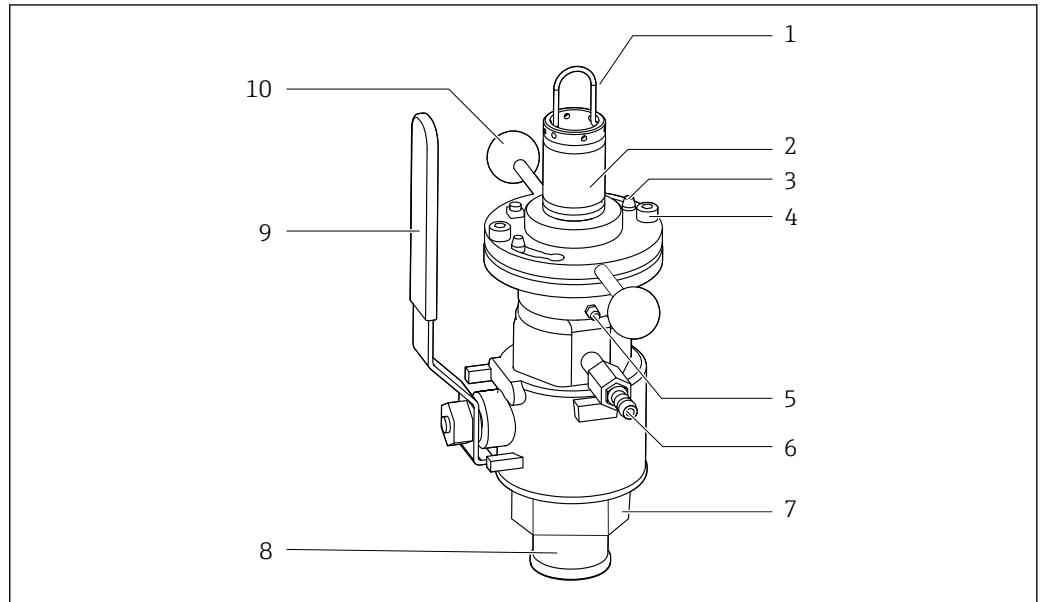

 1 Assembly in operational state (ball valve open)

- 1 Bracket for sensor holder
- 2 Sensor holder
- 3 Bayonet lock
- 4 Securing screws
- 5 Grease nipple
- 6 Ball valve for venting or rinse connection
- 7 Process connection
- 8 Retraction pipe
- 9 Hand lever for opening/closing the ball valve
- 10 Handles

 An additional rinse chamber valve can be mounted in the locking screw.

3.1.1 Universal sensor holder

The sensor holder is used to position the sensor correctly in order to ensure correct measuring accuracy.

If the sensor is not positioned correctly, the ball valve may be blocked or the sensor may be located in the dead space as a result.

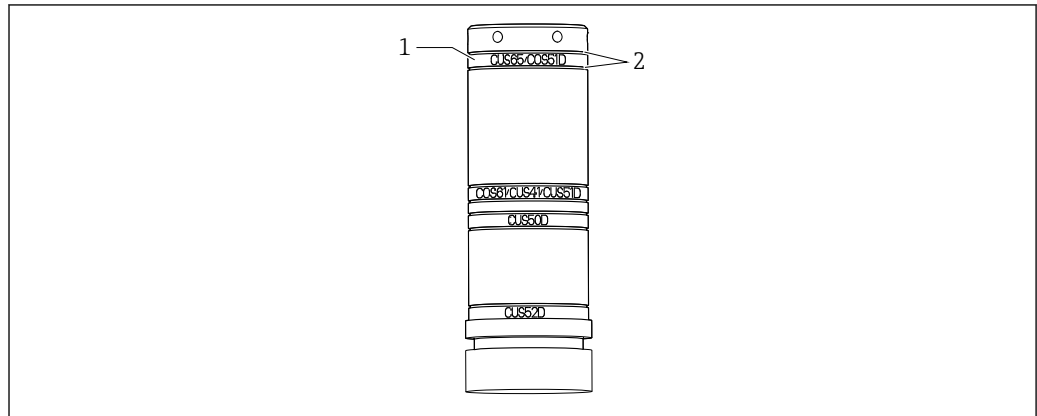

A0038451

2 Short sensor holder

- 1 Mounting position of the bayonet nut to hold the relevant sensor
- 2 Grooves of the safety rings to mount the bayonet nut

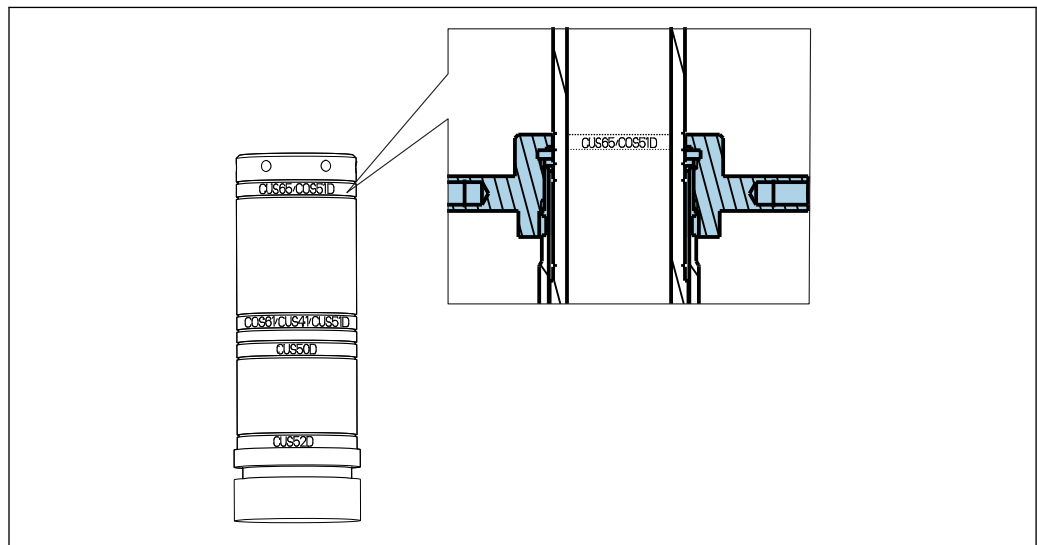

A0038479

3 Mounting position of the bayonet nut for CUS65D

-  The name indicated on the holder serves as a mounting aid. The bayonet nut covers over the marking for the selected sensor position.

4 Incoming acceptance and product identification

4.1 Incoming acceptance

1. Verify that the packaging is undamaged.
 - ↳ Notify the supplier of any damage to the packaging.
Keep the damaged packaging until the issue has been resolved.
2. Verify that the contents are undamaged.
 - ↳ Notify the supplier of any damage to the delivery contents.
Keep the damaged goods until the issue has been resolved.
3. Check that the delivery is complete and nothing is missing.
 - ↳ Compare the shipping documents with your order.
4. Pack the product for storage and transportation in such a way that it is protected against impact and moisture.
 - ↳ The original packaging offers the best protection.
Make sure to comply with the permitted ambient conditions.

If you have any questions, please contact your supplier or your local Sales Center.

4.2 Product identification

4.2.1 Nameplate

The nameplate provides you with the following information on your device:

- Manufacturer identification
 - Order code
 - Extended order code
 - Operating conditions
 - Serial number
 - Safety information and warnings
 - Approvals as per version ordered
- ▶ Compare the information on the nameplate with the order.

4.2.2 Identifying the product

Product page

www.endress.com/CUA451

Interpreting the order code

The order code and serial number of your product can be found in the following locations:

- On the nameplate
- In the delivery papers

Obtaining information on the product

1. Go to www.endress.com.
2. Call up the site search (magnifying glass).
3. Enter a valid serial number.
4. Search.
 - ↳ The product structure is displayed in a popup window.

5. Click on the product image in the popup window.
 - ↳ A new window (**Device Viewer**) opens. All of the information relating to your device is displayed in this window as well as the product documentation.

4.2.3 Manufacturer address

Endress+Hauser Conducta GmbH+Co. KG
Dieselstraße 24
D-70839 Gerlingen

4.3 Scope of delivery

The delivery comprises:

- Assembly in the version ordered
 - Operating Instructions
- ▶ If you have any queries:
Please contact your supplier or local sales center.

4.4 Certificates and approvals

4.4.1 CE/PED

The assembly has been manufactured according to good engineering practice as per Article 4, Paragraph 3 of the Pressure Equipment Directive 2014/68/EU and is therefore not required to bear the CE label.

5 Installation

5.1 Installation conditions

5.1.1 Dimensions

Assembly with G2 thread and weld-in adapter in measuring position (long and short stroke)

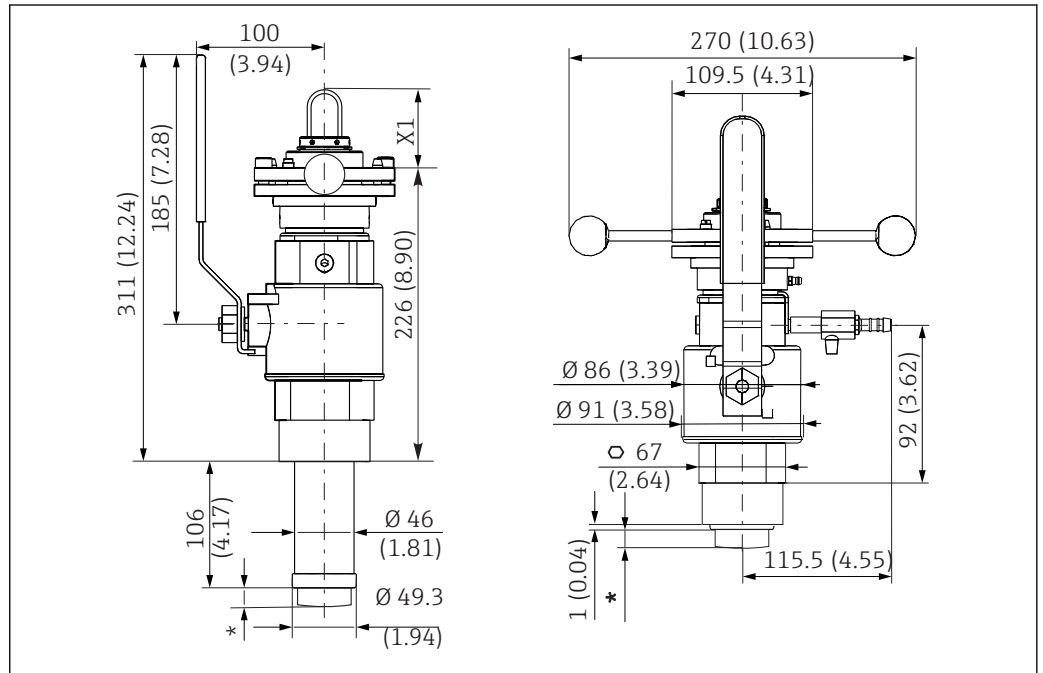

4 Dimensions in mm (in)

X1 Dimensions depend on the sensor

A0038481

Assembly with G2 thread and weld-in adapter in service position (long and short stroke)

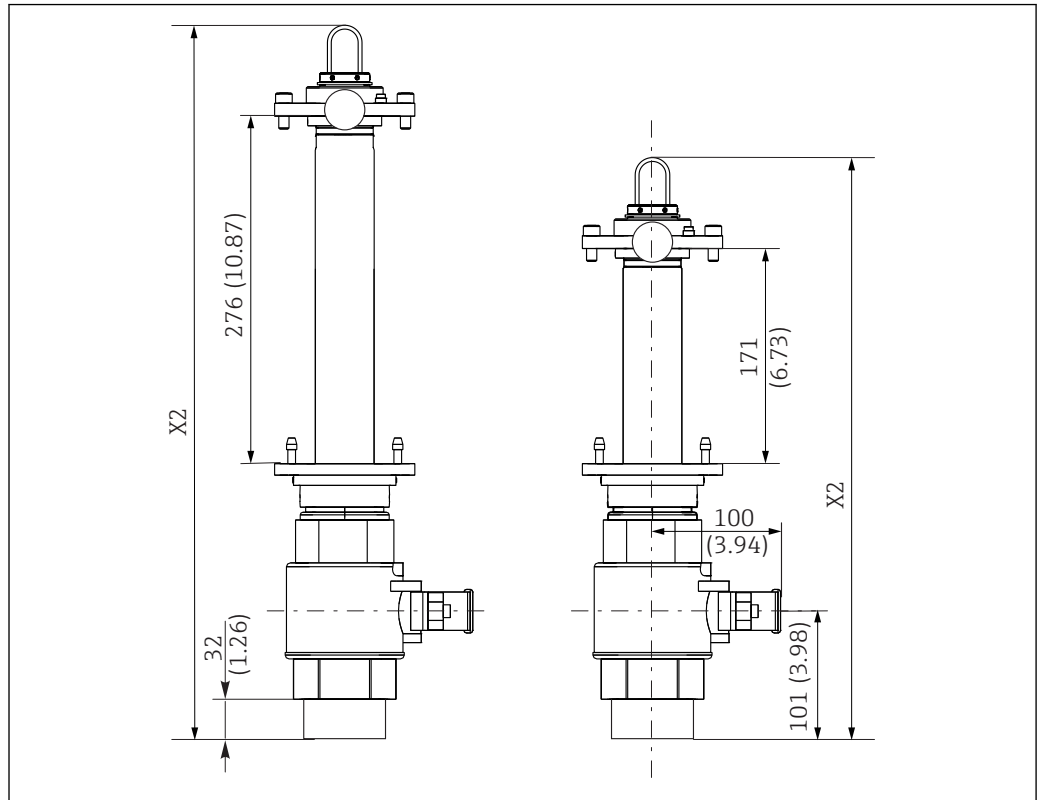

A0038630

5 Dimensions in mm (in)

X2 Dimensions depend on the sensor

Assembly with flange connection

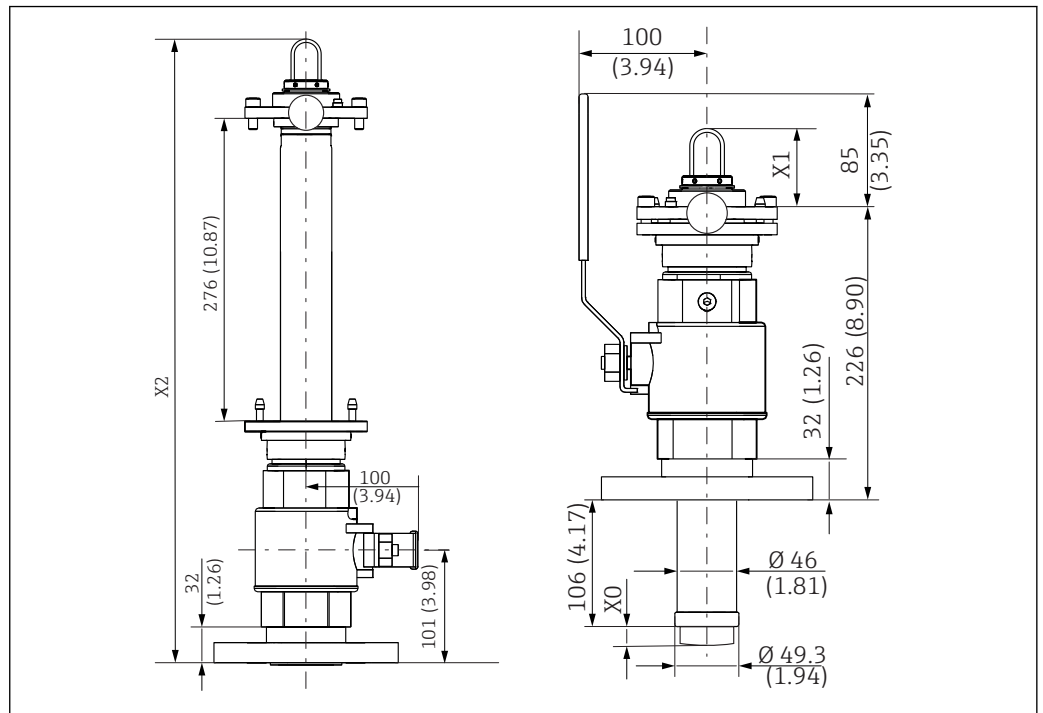

A0038651

6 Dimensions in mm (in)

X0 Dimensions depend on the sensor

Sensor	X0
CUS52D	26.5 (1.04)
CUS50D	26.3 (1.04)
CUS41/CUS51D, COS61D	14 (0.55)
CUS65, COS51D	21.3 (0.84)

Sensor measuring position	X1
CUS52D	139 (5.47)
CUS50D	110 (4.33)
CUS41/CUS51D, COS61D	101 (3.98)
CUS65, COS51D	59 (2.32)

Sensor service position, long	X2
CUS52D	638 (25.12)
CUS50D	609 (23.98)
CUS41/CUS51D, COS61D	600 (23.62)
CUS65, COS51D	558 (21.97)

Sensor service position, short	X2
CUS52D	533 (20.98)
CUS50D	504 (19.84)
CUS41/CUS51D, COS61D	495 (19.49)
CUS65, COS51D	453 (17.83)

Sensor holder with sensors

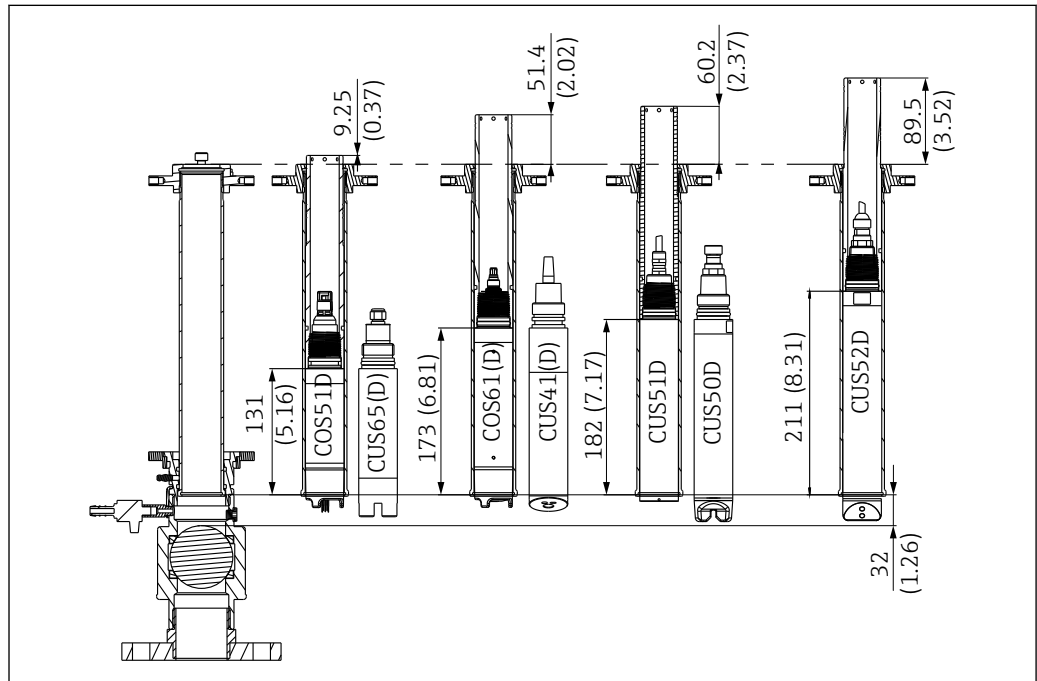

A0038478

7 Dimensions of sensor holder with sensors in mm (in)

5.1.2 Process connections

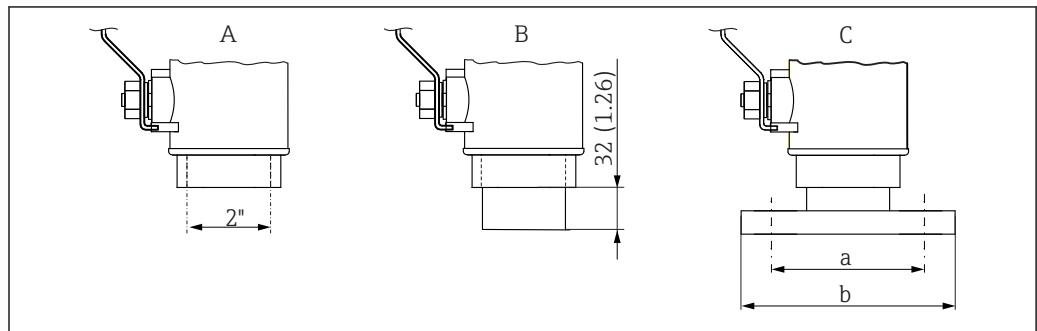

A0038650

8 Dimensions of process connections in mm (in)

- A Internal thread G2
- B Internal thread G2 with weld-in adapter
- C Flange DN 50 / PN 16 (as per EN 1092-1) and flange ANSI 2" / 150 lbs
- a DN 50: Ø 125 (4.92), ANSI 2": Ø 120.7 (4.75)
- b DN 50: Ø 165 (6.50), ANSI 2": Ø 152.4 (6.00)

5.1.3 Installation instructions

Installation location

The assembly is designed for installation on vessels and pipes. Suitable nozzles must be available for this. The minimum pipe diameter is DN 80.

- ▶ Before mounting the sensor, mount the assembly on the vessel or in the pipe.

The following diagram shows different installation positions in pipes, and indicates whether they are permitted or not.

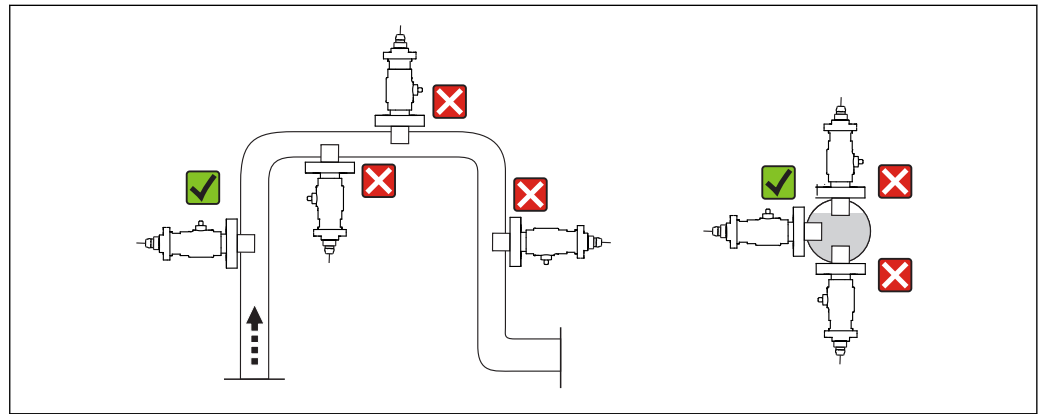

9 Schematic of installation positions and orientations

- ▶ Ideally, the assembly should be mounted in an ascending pipe. Installation in a horizontal pipe is also possible.
 - When using reflective materials (e.g. stainless steel), the pipe diameter must be at least 100 mm (4"). An onsite calibration is recommended.
 - Install the sensor in places with uniform flow conditions.
 - Do not install the sensor in places where air may collect or foam bubbles form or where suspended particles may settle.
 - Avoid installation in the down pipe.
 - Avoid fittings downstream from pressure reduction stages which can lead to outgassing.

Orientations

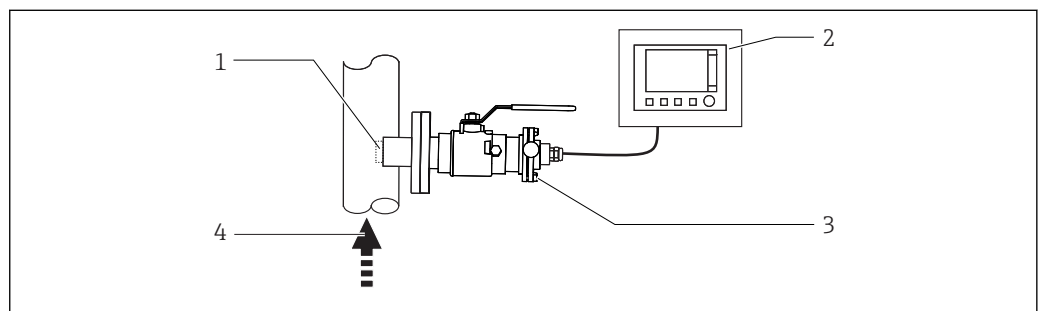

10 Orientations, schematic

- 1 Sensor (see Accessories)
- 2 Transmitter
- 3 CUA451 retractable assembly
- 4 Direction of flow

- i** The orientation depends on the sensor head. Pay attention to the Operating Instructions for the relevant sensor.

- ▶ Make sure to avoid a siphon effect at the rinse chamber outlet. The inflow to the rinse chamber is always from below.

Clearance between the sensor and pipe wall

If the sensor is installed in pipes or very close to the wall, this can cause backscatter and therefore a higher sensor signal.

- ▶ Follow the instructions in the Operating Instructions for the sensor used.

5.2 Mounting the assembly

WARNING

Medium flows out.

Risk of injury

- ▶ Only install the assembly when the process is deactivated.
- ▶ Before disassembling, always ensure that the process pipe and vessel are unpressurized, empty and rinsed.
- ▶ Move the assembly to the service position.
- ▶ Close the ball valve.

5.2.1 Installing the assembly in the process

1. Mount the hand lever on the assembly.
2. Open the ball valve.
3. Move the assembly to the service position.
 - ↳ Retraction pipe is in the assembly.
4. Secure the assembly to the vessel or pipe using the selected process connection.

Flange process connection:

- ▶ Prior to installation, check the flange seal between the flanges.

G2 process connection

- ▶ Use a commercially available sealant (e.g. LOCTITE 561) to seal the G2 process connection.

5.2.2 Rinse water connection (optional)

NOTICE

Water pressure too high

The assembly can be damaged.

- ▶ A pressure-reducing valve must be connected in series upstream if the water pressure can increase to over 6 bar (87 psi).

Rinse the sensor in the service position with a second ball valve for the rinse chamber (see accessories).

1. Connect the rinse water line to the rinsing nozzle provided. The two rinse nozzles on the assembly are identical and can be used in the inlet and outlet.
2. Operate the rinse water connection of the assembly with a water pressure of 2 bar to max. 6 bar (29 to 87 psi).
3. Also install a check valve and a dirt trap (100 µm, see "Accessories") in the water pipe (at the inlet to the assembly).

-  Apart from water, you can also pass other or additional cleaning solutions through the rinse chamber. When doing so, pay attention to the material resistance of the assembly and make sure to comply with the maximum permitted temperatures and pressures.

5.2.3 Sensor installation

CAUTION

High pressure in the rinse chamber

Risk of injury from medium and pressure.

- ▶ Connect a hose to the vent valve and vent the rinse chamber carefully.

Releasing the screws

Use the following tools to install the sensor:

- 2.5 mm Allen screw
- 6 mm Allen screw

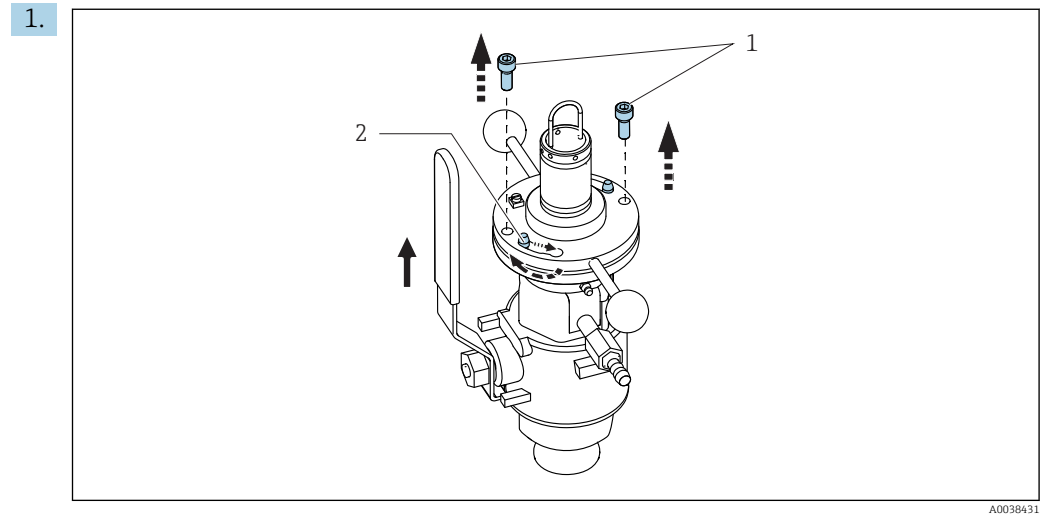

Release the securing screws (item 1) and put them in a safe place within reach.

2. Turn the bayonet nut.
 ↳ The bayonet lock (item 2) is released.

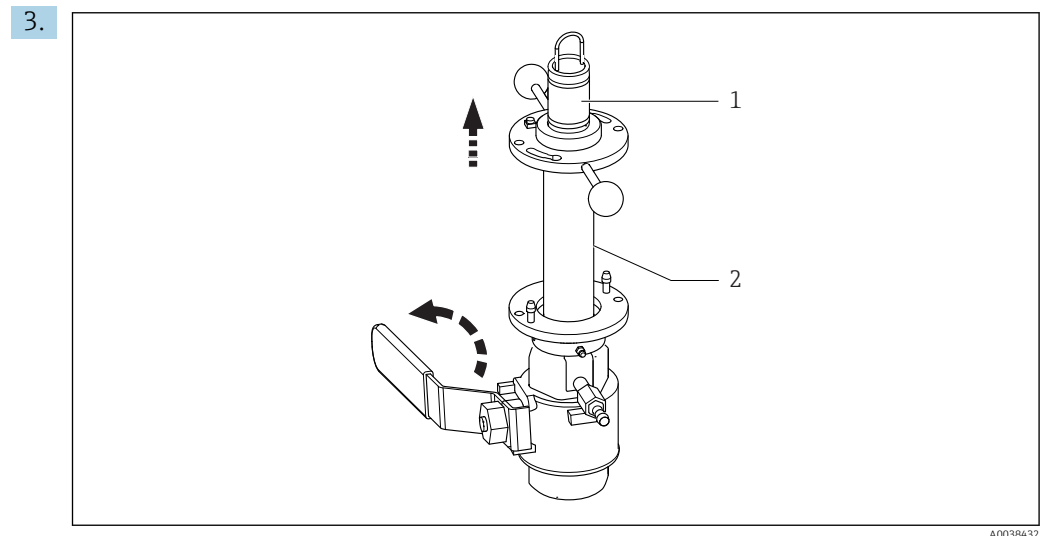

Taking the handles, pull out the retraction pipe (item 2) together with the sensor holder (item 1) as far as it will go.

4. Close the ball valve! Push down the hand lever as far as possible (only possible in one direction!).
 ↳ When the ball valve is closed, the assembly is sealed from the process.
5. Connect a hose to the vent valve.
6. Vent the rinse chamber.

7.

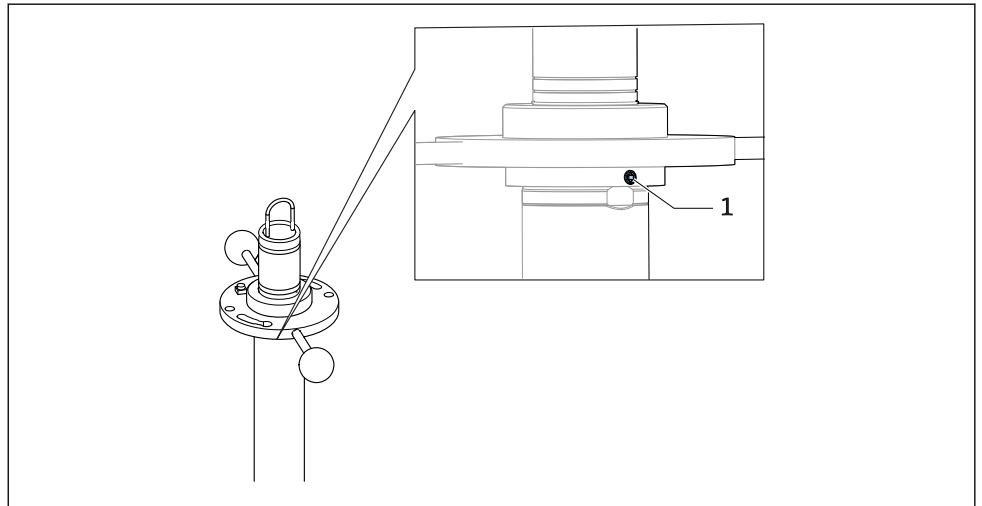

A0038433

Release the grub screw (item 1) on the underside of the bayonet nut.

8.

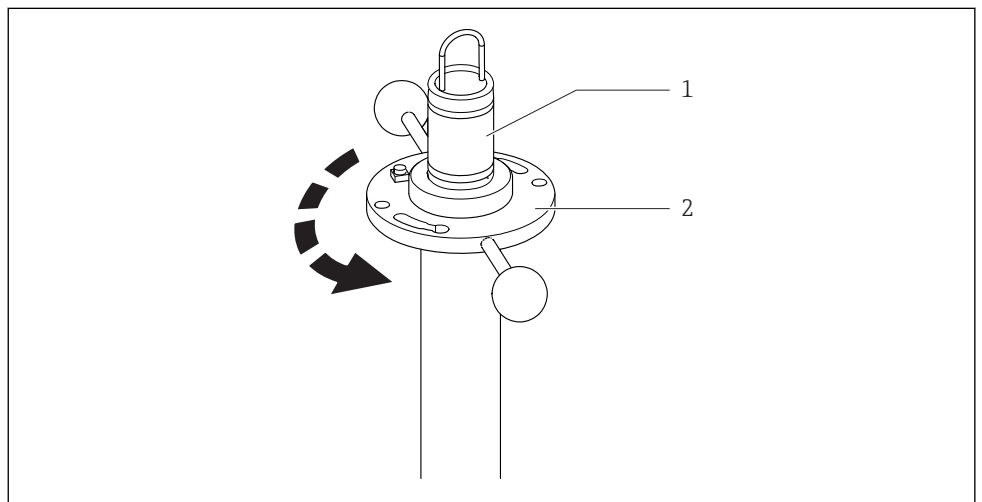

A0038434

Unscrew the bayonet nut and the sensor holder (item 1) from the retraction pipe. In doing so, hold the retraction pipe steady and turn the handles (2) counterclockwise (approx. 9 turns).

9. Holding the handles, pull the bayonet nut, along with the sensor holder, out of the retraction pipe.

i When the sensor is installed, the bracket is the only possible way to check the alignment of the sensor in the process! Observe the instructions on sensor alignment in the Operating Instructions for the sensor.

Screwing in the sensor

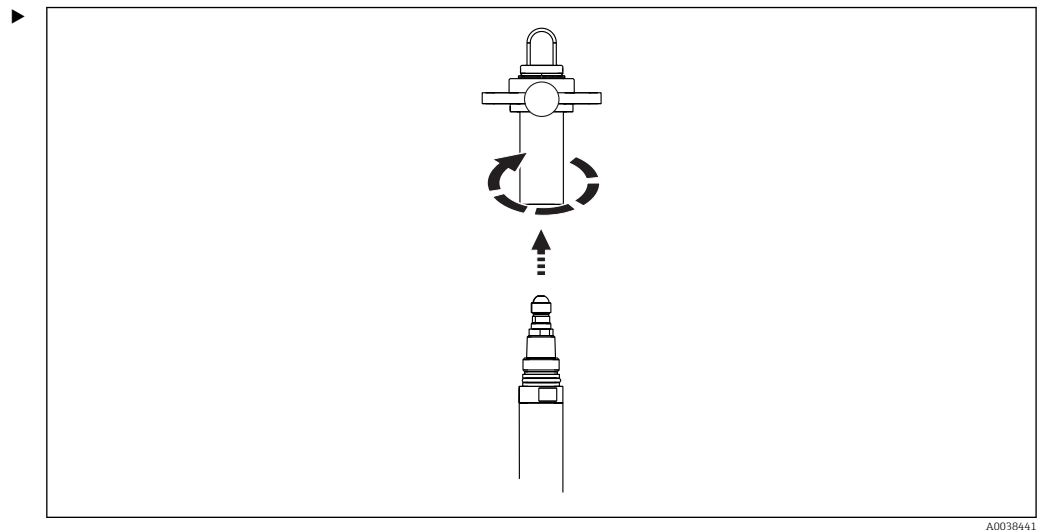

Screw the sensor hand-tight into the internal thread of the sensor holder.

Aligning the bracket

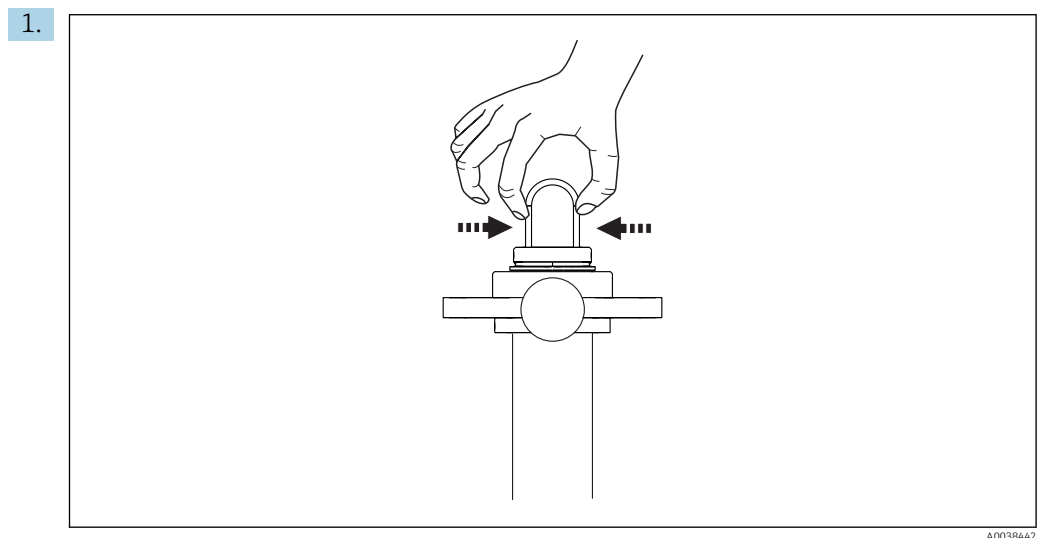

Push the bracket out of the installation bore holes.

- ↳ The sensor holder bracket can be fitted in various positions at 60° intervals. In this way, you can use the bracket to mark the position of the sensor in the retraction pipe.

2.

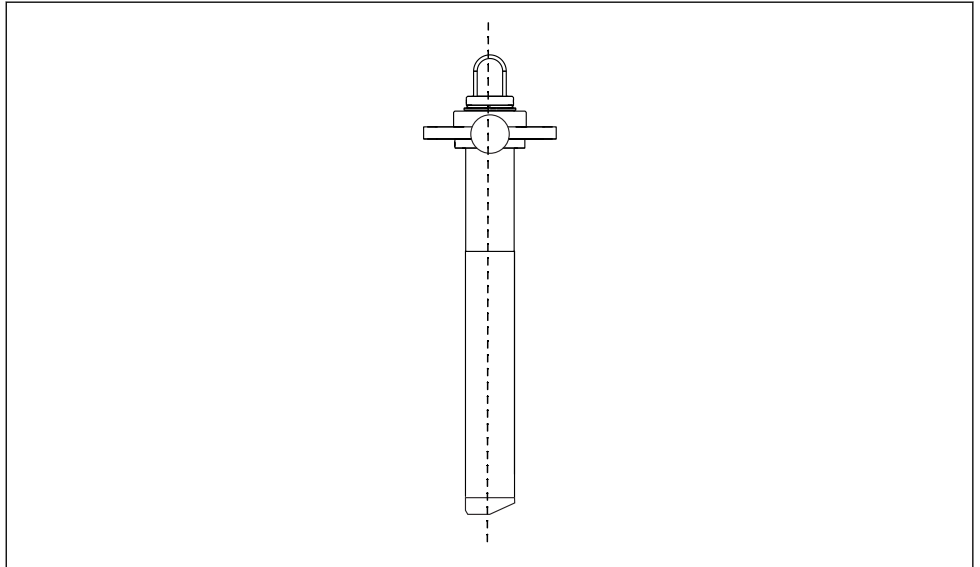

A0038443

 11 Bracket alignment taking the example of the CUS52D sensor

While paying attention to the flow side of the sensor, align the bracket with the axis of the sensor head.

- ↳ In this way, you can determine the position of the sensor surface in the process and align the sensor with the medium flow.

3. Push the bracket into the desired installation bore holes.

Fitting the sensor in the assembly

1. Fit the mounted sensor into the retraction pipe.

2.

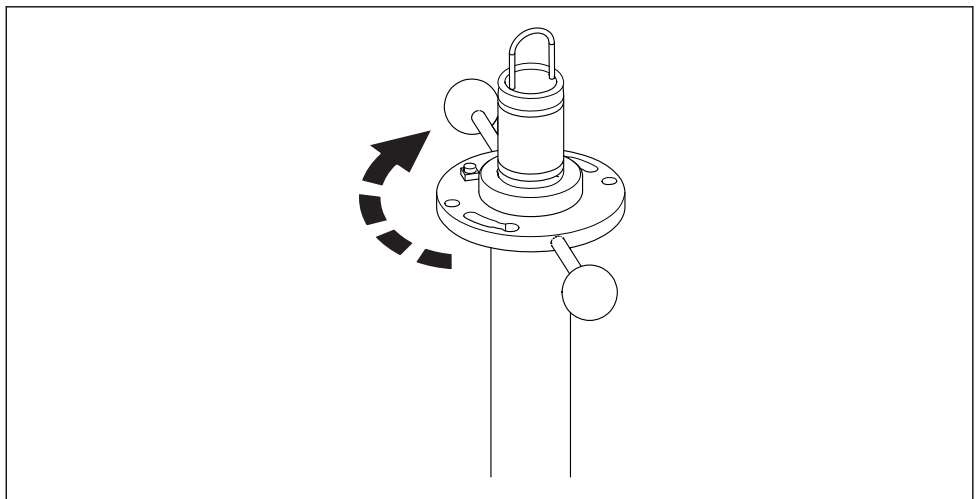

A0038444

Hold the retraction pipe steady and tighten the bayonet nut (turn the handles clockwise).

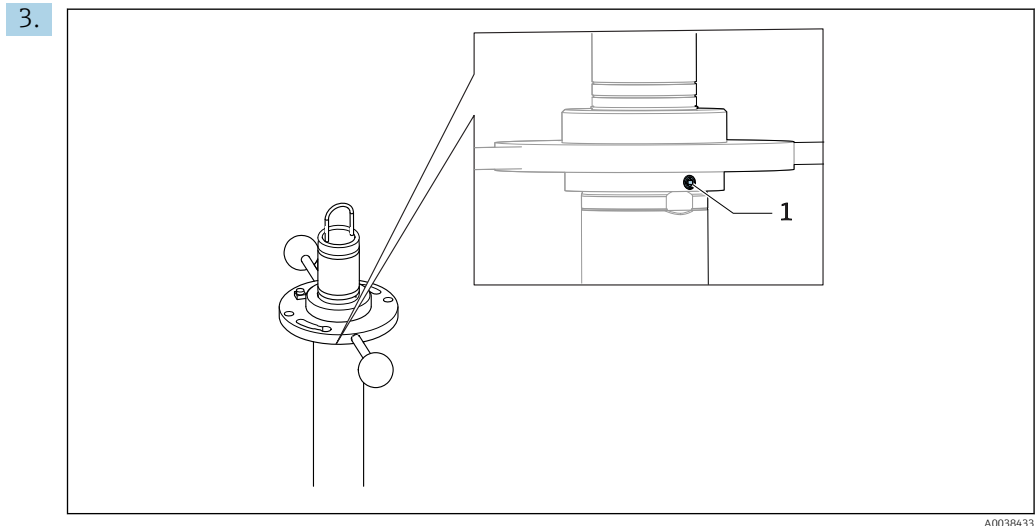

Tighten the grub screw of the bayonet nut.

4. Connect the rinse chamber connection.

Fitting the sensor in the assembly

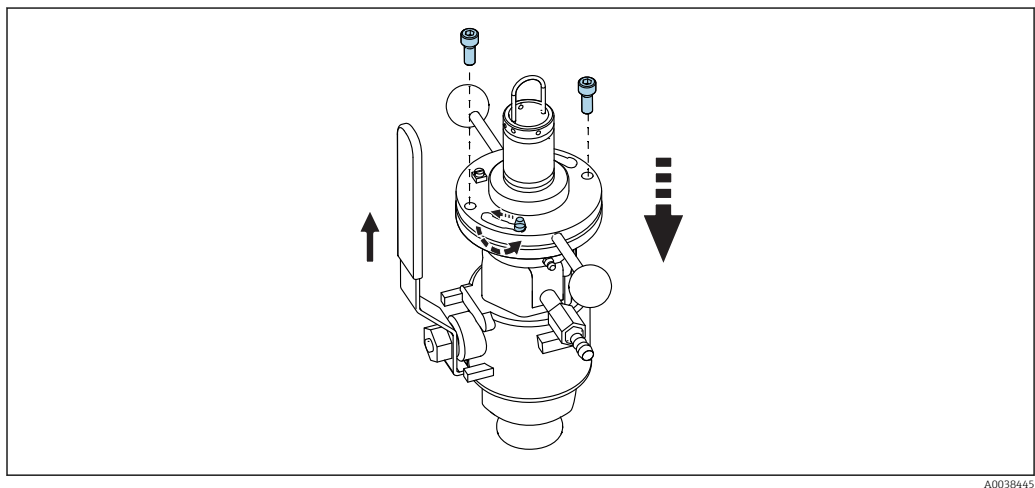

1. Push up the hand lever as far as possible.
 - ↳ The ball valve is open.
2. Grease the retraction pipe.
 - ↳ This helps the retraction pipe move more smoothly in the direction of the measuring position.
3. Push the retraction pipe in the direction of the measuring position as far as it will go.
 - ↳ The retraction pipe with the sensor is in the measuring position.
4. Hold the bayonet lock steady and close it.
5. Secure the retraction pipe with the securing screws.
6. Turn the entire top assembly part around its own axis until the sensor is in the right position in relation to the medium flow.

5.2.4 Fitting the sensor holder onto another sensor

The universal sensor holder can subsequently be fitted onto another sensor.

The sensor holder has several sensor-specific grooves.

The desired sensor is aligned at the grooves.

Disassembling the sensor holder

Use the following tools to install the sensor:

- 2.5 mm Allen screw
- 6 mm Allen screw

1.

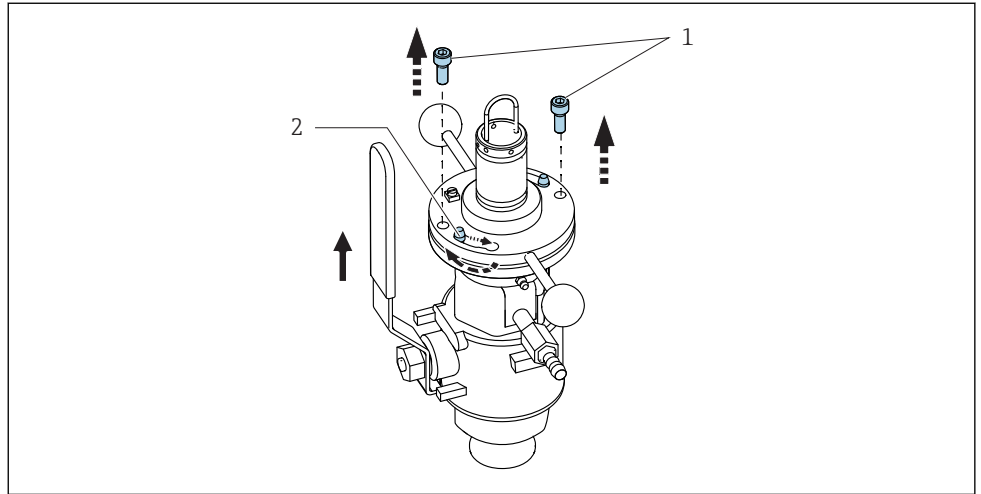

A0038431

Release the securing screws (item 1) and put them in a safe place within reach.

2.

Turn the bayonet nut.

↳ The bayonet lock (item 2) is released.

3.

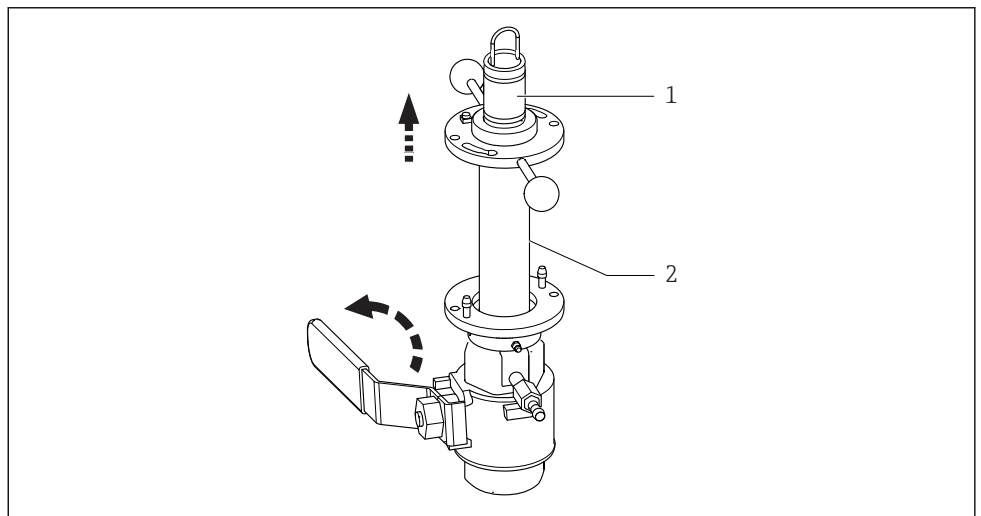

A0038432

Taking the handles, pull out the retraction pipe (item 2) together with the sensor holder (item 1) as far as it will go.

4.

Close the ball valve! Push down the hand lever as far as possible (only possible in one direction!).

↳ When the ball valve is closed, the assembly is sealed from the process.

5.

Connect a hose to the vent valve.

6.

Vent the rinse chamber.

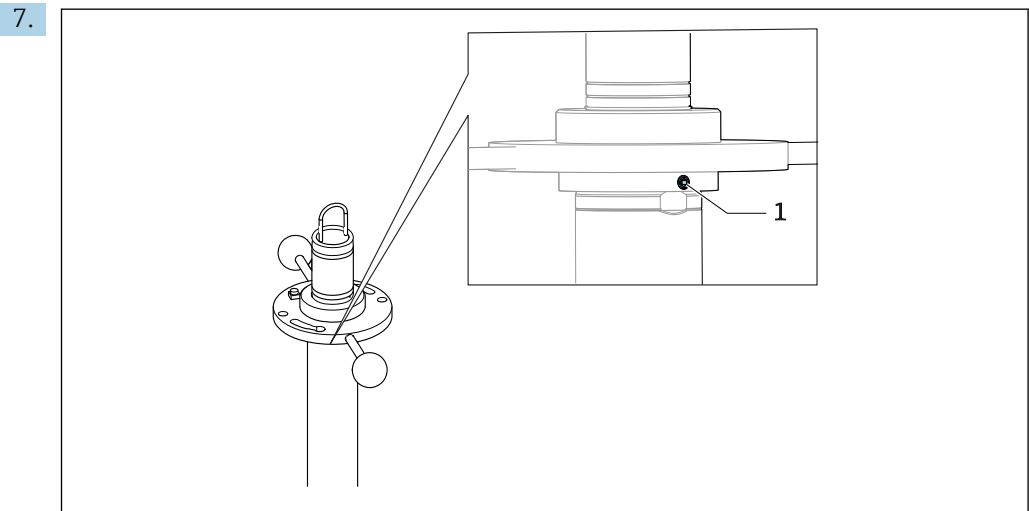

A0038433

Release the grub screw (item 1) on the underside of the bayonet nut.

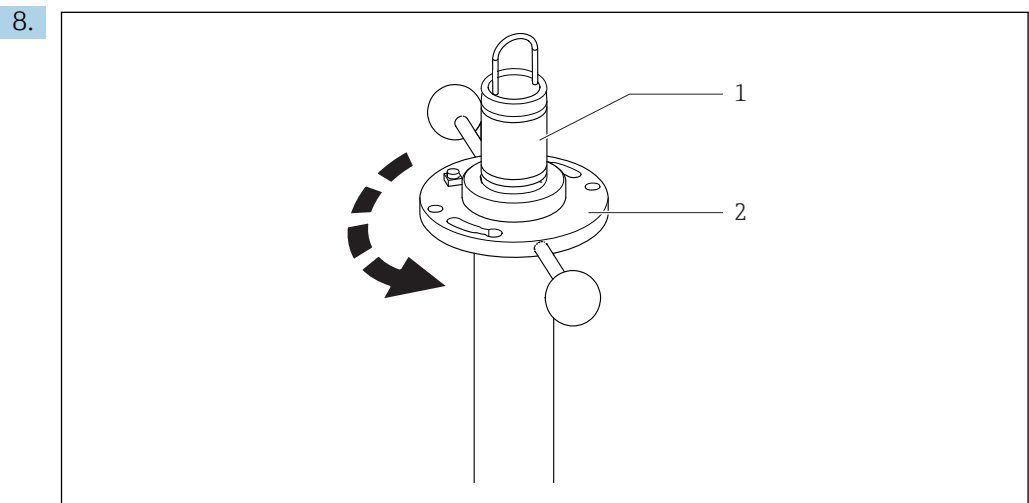

A0038434

Unscrew the bayonet nut and the sensor holder (item 1) from the retraction pipe. In doing so, hold the retraction pipe steady and turn the handles (2) counterclockwise (approx. 9 turns).

9. Holding the handles, pull the bayonet nut, along with the sensor holder, out of the retraction pipe.
10. Clean the sensor holder, sensor and seals if necessary.

Removing the sensor

Use the following tools to remove the sensor:

- Special pliers with flat jaws for outer locking rings without bores
- Alternatively a small screwdriver

1. Remove the top locking ring with the special pliers on the sensor holder above the bayonet nut. The position of the bottom locking ring does not need to be changed.
2. Hold the sensor steady and unscrew the sensor holder from the sensor.

For fixed cable sensors

1. Release the sensor cable on the transmitter or junction box.
2. Remove the cable from the bayonet nut and sensor holder.

For sensors with the Memosens plug-in head

- ▶ Release the Memosens cable on the sensor.

Changing the position of the locking ring

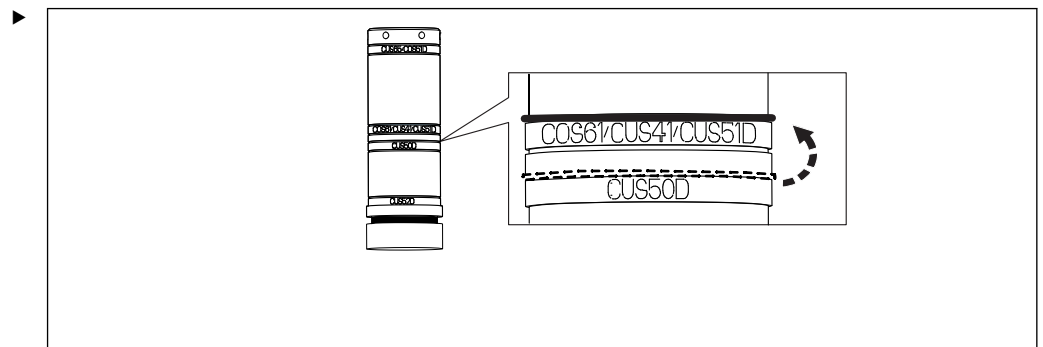

A0038801

Move the locking ring into the correct groove that corresponds to the sensor type.

- ↳ The sensor marking on the sensor holder is no longer visible. → 8

Installing the sensor

1.

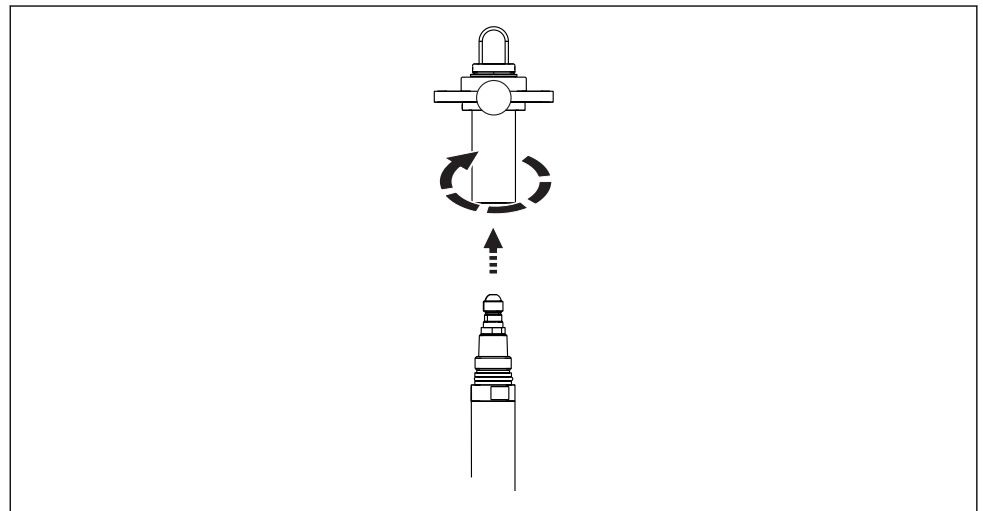

A0038441

Screw the sensor hand-tight into the internal thread of the sensor holder.

2. Fit the mounted sensor into the retraction pipe.
3. Hold the retraction pipe steady and tighten the bayonet nut (turn the handles clockwise).
4. Tighten the grub screw of the bayonet nut.
5. Connect the rinse chamber connection.
6. Push up the hand lever as far as possible.
 - ↳ The ball valve is open.
7. Grease the retraction pipe.
 - ↳ This helps the retraction pipe move more smoothly in the direction of the measuring position.
8. Secure the retraction pipe with the securing screws.

5.3 Post-installation check

- After mounting, check all the connections to ensure they are secure and leak-tight.
- Ensure that the hoses of the (optional) rinse water connections cannot be removed without force. These pipes are in open contact with the medium and must be secured accordingly.
- Check the hoses for damage.

6 Commissioning

6.1 Preparatory steps

⚠ WARNING

Risk of injury if medium escapes!

- ▶ Before commissioning, check whether rinse hoses are connected to the assembly or whether dummy plugs are fitted at the rinse connections.
- ▶ Otherwise, do not introduce the assembly into the process.

Before commissioning check whether:

1. All seals are correctly seated on the assembly and on the process connection.
2. The sensor is correctly installed and connected.

7 Operation

7.1 Adapting the device to the process conditions

7.1.1 From the service position to the measuring position

1. Check the rinse chamber connections to ensure they are closed.
2. Open the ball valve.
3. Push the retraction pipe in the direction of the process as far as it will go.
4. Lock the retraction pipe via the bayonet lock.
5. Secure with the securing screws.
 - ↳ The sensor holder is now secure and cannot move back accidentally.
6. At the handles, turn the top assembly part around its own axis in order to align the sensor.

7.1.2 From the measuring position to the service position

1. Release the securing screws with an Allen key.
2. Open the bayonet lock.
3. Pull out the sensor holder as far as it will go (service position).
4. Close the ball valve.
5. Vent the rinse chamber.
6. Perform the necessary service work.

8 Maintenance

⚠ WARNING

Medium flows out.

Risk of injury

- ▶ Only install the assembly when the process is deactivated.
- ▶ Before disassembling, always ensure that the process pipe and vessel are unpressurized, empty and rinsed.
- ▶ Move the assembly to the service position.
- ▶ Close the ball valve.

8.1 Maintenance tasks

NOTICE

Unfavorable ambient conditions such as plant vibrations or atmospheres that encourage corrosion can affect the functional integrity of the safety ring.

There is the danger of the ring breaking or coming free from the groove.

- ▶ Visually inspect for potential signs of corrosion.
- ▶ Make sure that the ring is fully seated in the groove.

8.1.1 Cleaning agent

The choice of cleaning agent depends on the degree and type of contamination. The most common types of contamination and the appropriate cleaning agents can be found in the following table.

Type of contamination	Cleaning agent
Greases and oils	Agents containing surfactants (alkaline agents) or water-soluble organic solvents (halogen-free, e.g. ethanol)
Limescale deposits, metal hydroxide buildup, lyophobic biological buildup	Approx. 3% hydrochloric acid
Sulfide deposits	Mixture of 3% hydrochloric acid and thiocarbamide (commercially available)
Protein buildup	Mixture of 3% hydrochloric acid and pepsin (commercially available)
Fibers, suspended substances	Pressurized water, possibly surface-active agents
Light biological buildup	Pressurized water

⚠ CAUTION

Inhalation of solvents

Health hazard due to solvents

- ▶ Do not use any halogen-containing organic solvents or acetone. These solvents may destroy plastic components of the sensor and are also suspected carcinogens (e.g. chloroform).

8.1.2 Disassembling the assembly

Disassembling the sensor

All parts in contact with the medium, such as the sensor and the sensor guide, must be cleaned regularly.

Use the following tools to remove the sensor:

- 2.5 mm Allen screw
- 6 mm Allen screw

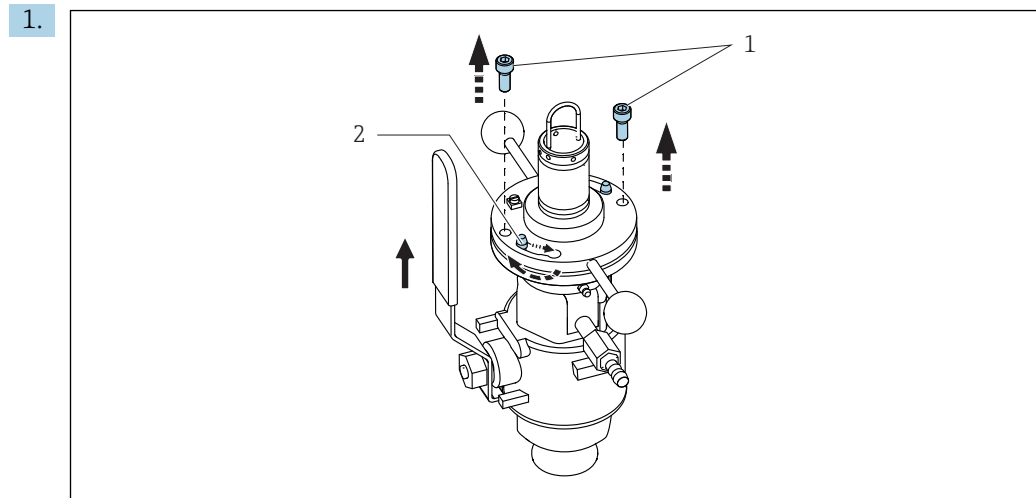

Release the securing screws (item 1) and put them in a safe place within reach.

2. Release the bayonet lock (item 2).

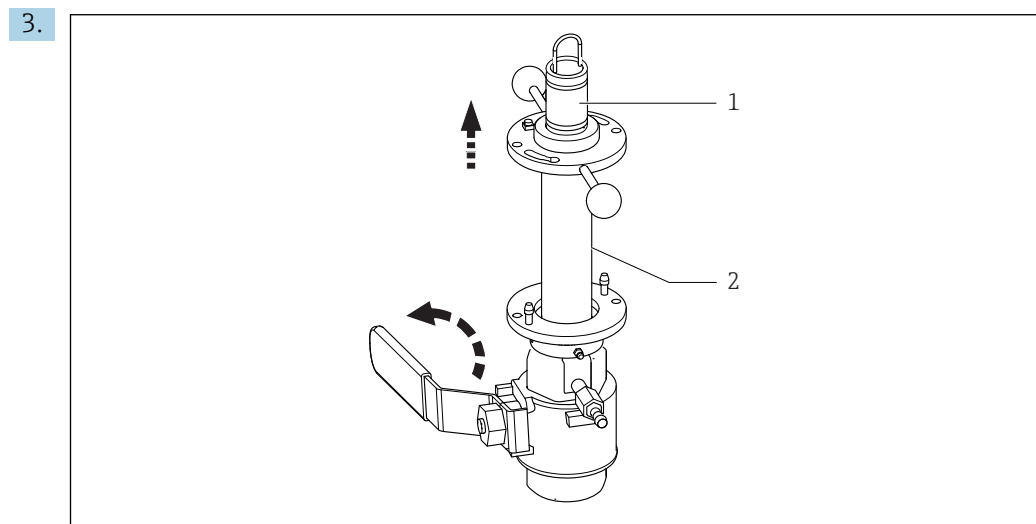

Taking the handles, pull out the retraction pipe (item 2) together with the sensor holder (item 1) as far as it will go.

4. Close the ball valve! Push down the hand lever as far as possible (only possible in one direction!).
- ↳ When the ball valve is closed, the assembly is sealed from the process.
5. Connect a hose to the vent valve.
6. Vent the rinse chamber.

7.

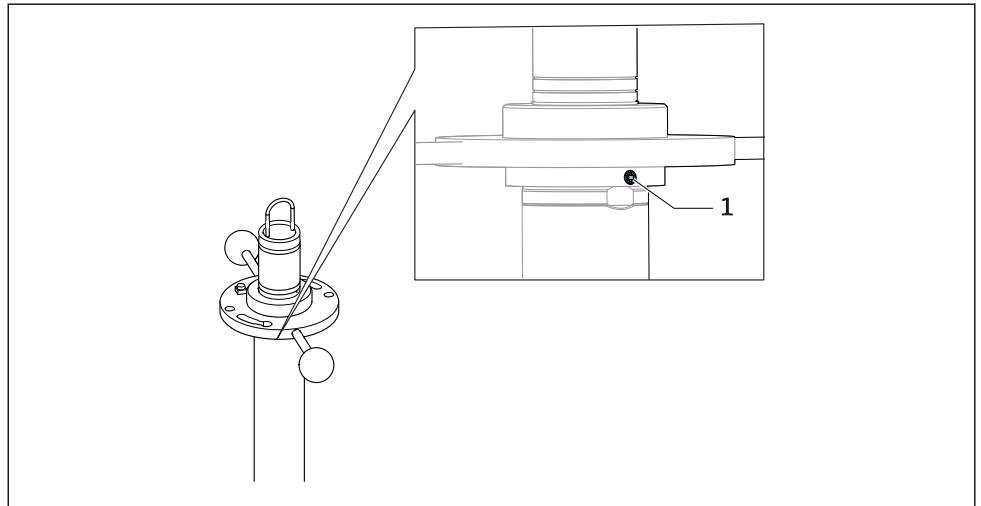

A0038433

Release the grub screw (item 1) on the underside of the bayonet nut.

8.

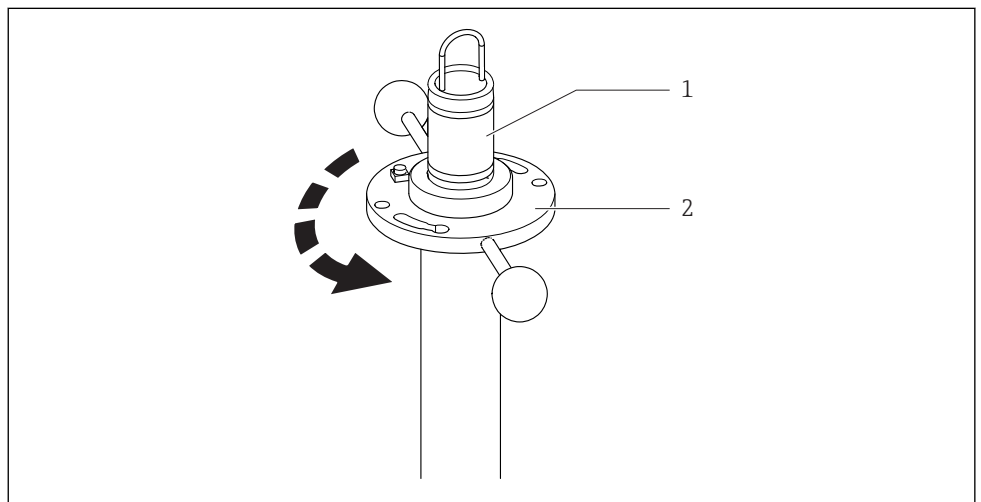

A0038434

Unscrew the bayonet nut and the sensor holder (item 1) from the retraction pipe. In doing so, hold the retraction pipe steady and turn the handles (2) counterclockwise (approx. 9 turns).

9. Holding the handles, pull the bayonet nut, along with the sensor holder, out of the retraction pipe.
10. Unscrew the sensor from the sensor holder.

8.1.3 Cleaning the assembly

To ensure stable and reliable measurements, the assembly and the sensor must be cleaned regularly. The frequency and intensity of the cleaning process depend on the medium.

i A typical example of a cleaning interval would be 6 months in the case of drinking water.

Cleaning the assembly

1. Remove light dirt and fouling with suitable cleaning solutions.
2. Remove heavy soiling using a soft brush and a suitable cleaning agent.
3. For very persistent dirt, soak the parts in a cleaning solution. Then clean the parts with a brush.

4. After cleaning, grease the retraction pipe to ensure the assembly moves in and out easily. A suitable grease is SYNTHESO GLEP 1 (from Klüber). PARALIQ GTE 703 (from Klüber) is suitable for use in the food sector.
5. Also grease the area between the O-rings using the grease nipple.

8.1.4 Replacing the seals

CAUTION

Residual medium and elevated temperatures can cause irritation

Risk of injury

- ▶ When handling parts that are in contact with the medium, protect yourself against residual medium and elevated temperatures.
- ▶ Wear protective goggles and safety gloves.

Keeping seals clean

1. Keep the sealing surfaces of the assembly free from dirt.
2. Remove caking and buildup from time to time.
3. If leaks are discovered, contact your Endress+Hauser sales office.

Preparing the assembly

The seals are available as an accessory kit. When replacing the seals, interrupt the process and remove the assembly completely.

Use the following materials and tools:

- Teflon tape
- Grease (e.g. SYNTHESO GLEP 1 or PARALIQ GTE 703)
- 2.5 mm Allen screw
- 6 mm Allen screw
- Adjustable open-ended wrench (up to 45 mm)
- Open-ended wrench set (only for flange connection)
- Flat screwdriver
- Adjustable pin wrench DIN 1810 B, size 68 to 75

1. Switch off the process
2. Empty the pipe or vessel.
3. Disassemble the assembly →  29

Removing the retraction pipe and sensor holder

1. Wrap Teflon tape around the thread of the retraction pipe. This protects the seals from damage when inserting and removing the retraction pipe.
 - ↳ The seals are therefore protected from damage when inserting and removing the retraction pipe.
2. Press the retraction pipe downwards out of the ball valve.
3. Using the screwdriver, remove the locking ring above the bayonet nut.
4. Remove the bayonet nut from the sensor holder.

Access to the seals

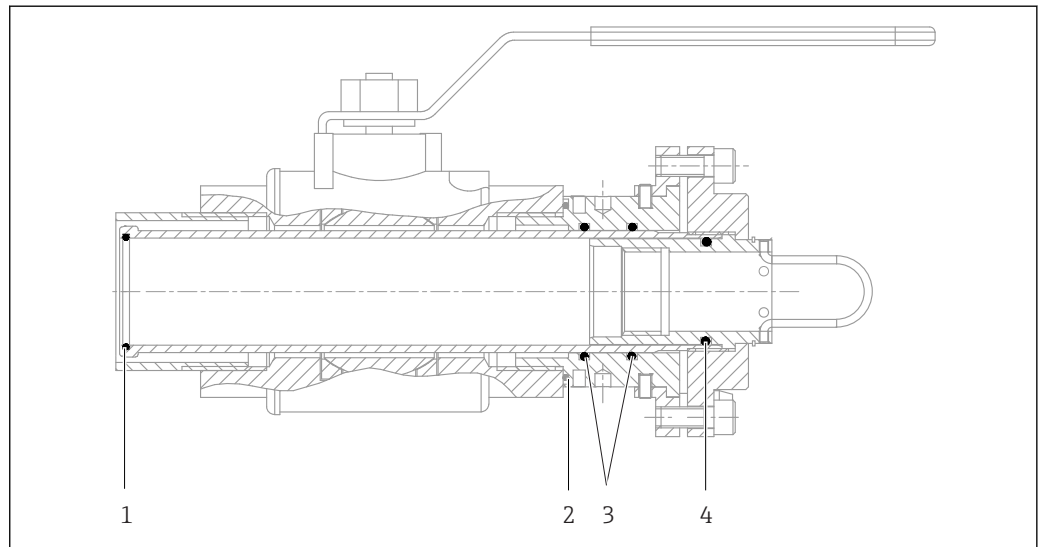

A0038663

12 Seals

- 1 Viton O-ring, retraction pipe
- 2 Viton O-ring, between ball valve and bottom part of bayonet lock
- 3 Viton O-rings, bottom part of bayonet lock
- 4 Viton O-ring, sensor holder

1. Only when replacing the O-ring, item 2: unscrew the vent cock (with safety bracket).
2. Only when replacing the O-ring, item 2: using a hook spanner, unscrew the bottom part of the bayonet lock.
 - ↳ The seals can now be accessed.

Replacing the seals and assembling the assembly

1. Lightly grease the O-rings (e.g. with Syntheso Glep 1).
2. Replace the seals (O-rings) if necessary.
3. If you have not already done so, wrap Teflon tape around the thread of the retraction pipe.
 - ↳ This protects the seals from damage when inserting the retraction pipe.
4. Grease the retraction pipe.
5. Reassemble the assembly.
6. Make sure that the locking ring above the bayonet nut is correctly seated.
7. Remove the Teflon tape once you have inserted the retraction pipe.
8. Check for leaks before returning the assembly to the measuring position.

9 Repair

9.1 General information

⚠ CAUTION

Risk of injury due to medium escaping and elevated temperatures

Pressure safety is compromised

- ▶ Damage to the assembly, which compromises pressure safety, must be repaired only by authorized and qualified personnel.
- ▶ Following all repair and maintenance work, suitable measures must be taken to check the assembly for leaks and ensure it is leak-tight. Following this, the assembly must again comply with the specifications in the technical data.

- ▶ Only use spare parts from Endress + Hauser to guarantee the safe and stable functioning of the device.

Detailed information on the spare parts is available at:

www.endress.com/device-viewer

- ▶ Following repairs, check that the device is complete, in a safe condition and functioning correctly.

9.2 Spare parts

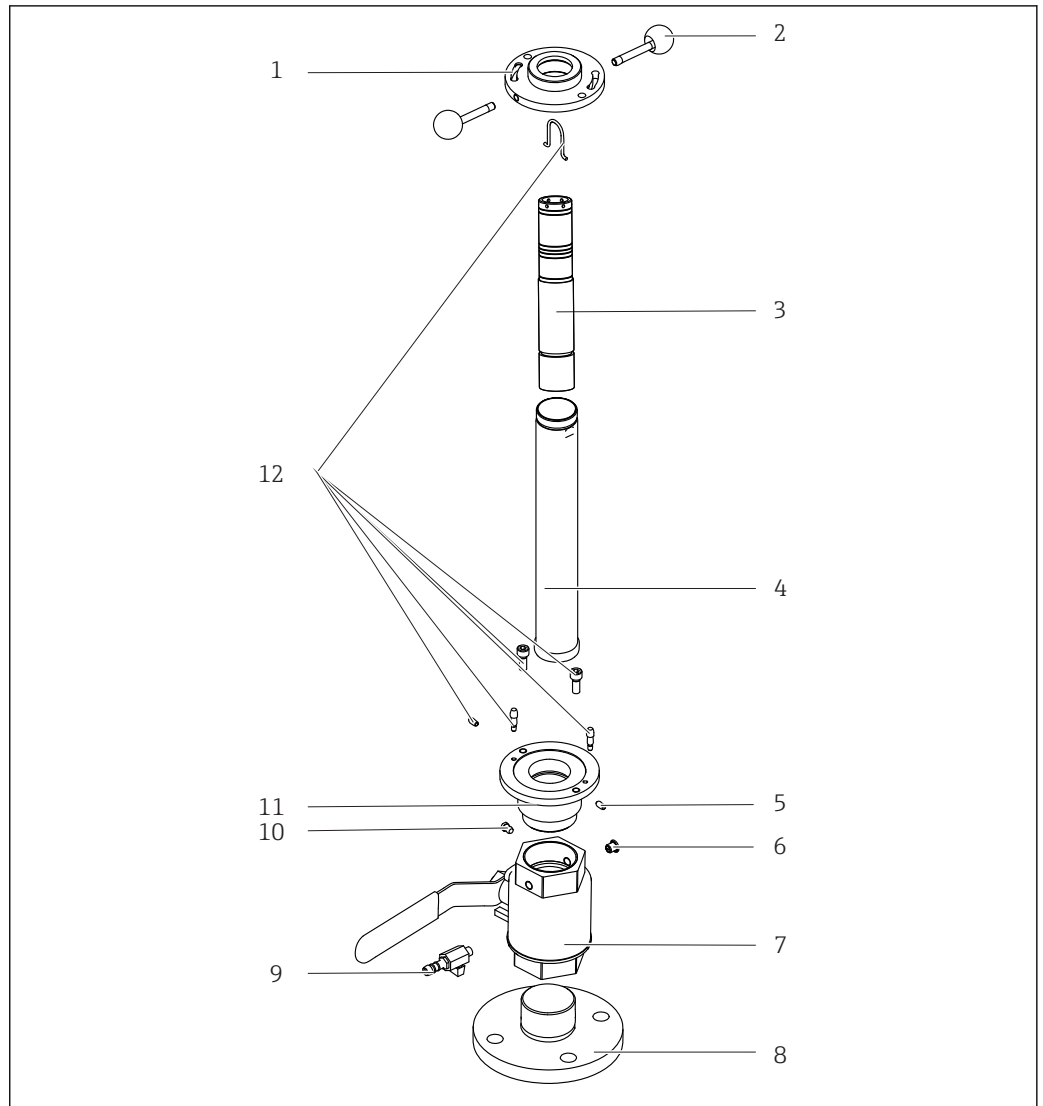

A0038665

13 Spare parts

- i** The bayonet lock nut (item 1) and dummy plug (item 6) are not available as a spare part.
- i** The sensor holders are used to adjust the length of the different sensors to a standard installation length.

Item No.	Description and contents	Order number of spare parts kit
2	Ball handle with bolts 2 of each	51513164
3	Kit: Kit universal sensor holder short	71425249
	Kit: Kit universal sensor holder long	71425251
	Kit: Kit retrofit univ. sensor holder short	71425252
	Kit: Kit retrofit univ. sensor holder long	71425253

Item No.	Description and contents	Order number of spare parts kit
	Kit: Kit locking rings new sensor holder	71425255
4	Retraction pipe (incl. FPM O-ring) For assembly version: long stroke	51513169
	Retraction pipe (incl. FPM O-ring) For assembly version: short stroke	51513156
7, 8, 11	Ball valve: Without flange, with G2 internal thread and bottom part of bayonet lock (8) with Viton O- rings	51513159
	Ball valve: With DN 50 flange, welding adapter (18) and bottom part of bayonet lock (8) with Viton O- rings	51513154
	Ball valve: With ANSI 2" flange, welding adapter (18), bottom part of bayonet lock (8) with Viton O- rings	51513155
9	Ball valve for rinse chamber as rinse connection or venting, hose connection OD 9	51512982
10	Grease nipple H1 M6x1	51514843
5,12	Kit: <ul style="list-style-type: none"> ▪ Bracket (11), 5 pcs ▪ Allen screws M8 x 20 (6), 10 pcs ▪ Stop bolt (15), 2 pcs ▪ Setscrews (7), 10 pcs 	51513158

9.3 Return

The product must be returned if repairs or a factory calibration are required, or if the wrong product was ordered or delivered. As an ISO-certified company and also due to legal regulations, Endress+Hauser is obliged to follow certain procedures when handling any returned products that have been in contact with medium.

To ensure the swift, safe and professional return of the device:

- ▶ Refer to the website www.endress.com/support/return-material for information on the procedure and conditions for returning devices.

9.4 Disposal

- ▶ Please observe local regulations!

10 Accessories

The following are the most important accessories available at the time this documentation was issued.

- ▶ For accessories not listed here, please contact your Service or Sales Center.

10.1 Device-specific accessories

10.1.1 Sensors

Turbimax CUS50D

- For nephelometric measurements of turbidity and solids in wastewater
- 4-beam scattered light method
- With Memosens technology
- Product Configurator on the product page: www.endress.com/cus50d

 Technical Information TI00461C

Turbimax CUS51D

- For nephelometric measurements of turbidity and solids in wastewater
- 4-beam scattered light method
- With Memosens technology
- Product Configurator on the product page: www.endress.com/cus51d

 Technical Information TI00461C

Turbimax CUS52D

- Hygienic Memosens sensor for turbidity measurement in drinking water, process water and in utilities
- With Memosens technology
- Product Configurator on the product page: www.endress.com/cus52d

 Technical Information TI01136C

10.1.2 Welding socket

Welding socket

- Welding socket for pipe diameter from 80 mm, with combination flange DN 50 / ANSI 2":
 - Bores for DN 50 flange: 4 x 90° Ø18 on bolt circle Ø125 (4.92)
 - Bores for ANSI 2" flange: 4 x 90° Ø19 on bolt circle Ø121 (4.75)
- Flange seal, 4 screws M16x60, 4 M16 nuts including washers,
- Stainless steel 1.4571 (AISI 316 Ti)
- Order No. 50080249

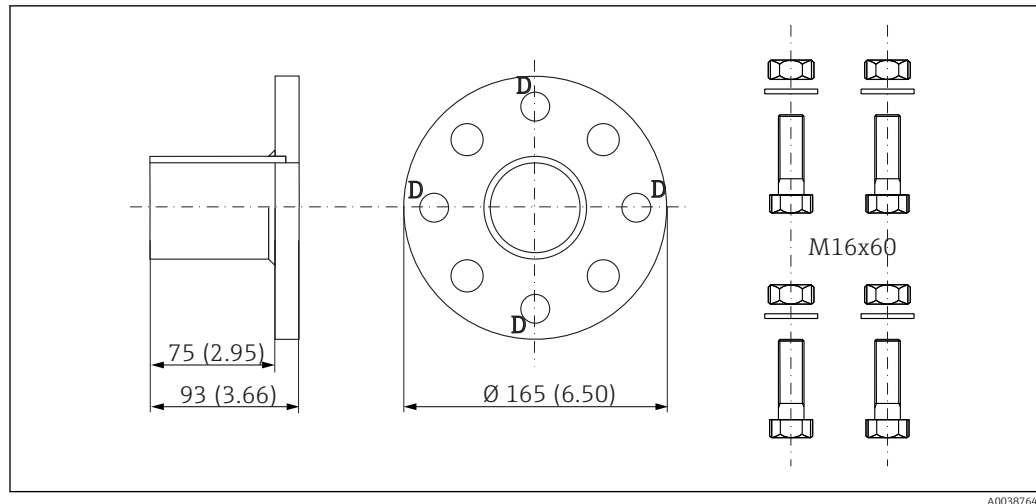

14 Welding socket, dimensions in mm (in)

D Markings for bores, DN 50 flange

Welding nipple

- Welding nipple for 2" thread
- Stainless steel 1.4404 (AISI 316 L)
- Order No. 71265347

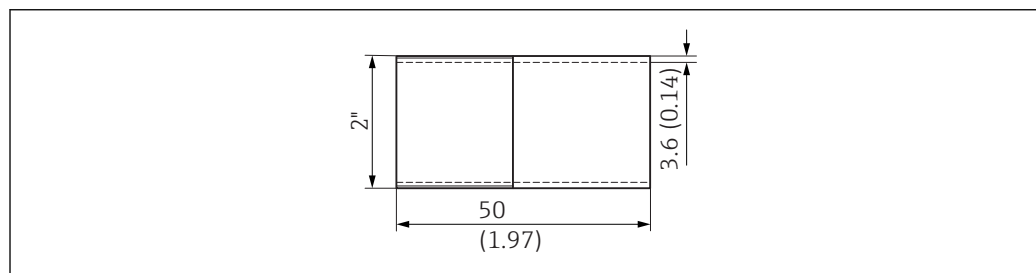

15 Welding nipple, dimensions in mm (in)

Welding rinse socket DN 65

- For automatic spray cleaning of CUS51D/31/41 sensors in pipes and vessels:
 - Bores for DN 50 flange: 4 x 90° Ø18 on bolt circle Ø125
 - Bores for ANSI 2" flange: 4 x 90° Ø19 on bolt circle Ø121
- Rinse connection: external thread R $\frac{1}{4}$
- With removable rinse nozzle
- Up to 6 bar (87 psi), 80 °C (176 °F)
- Order No. 51500912

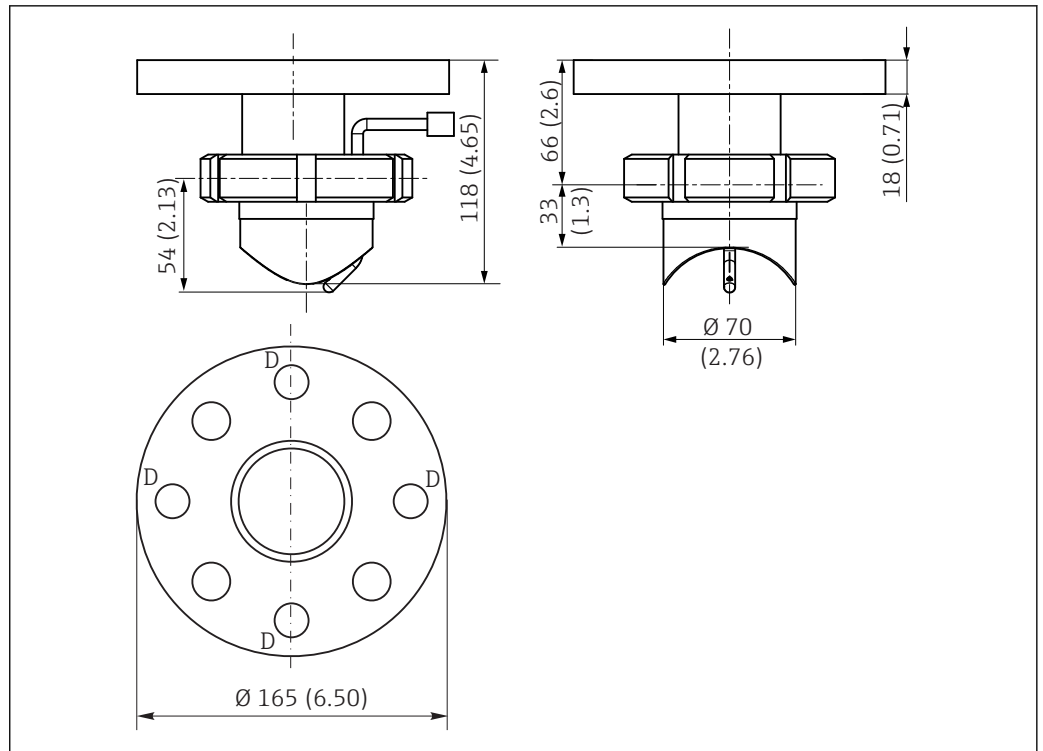

16 Welding rinse socket, dimensions in mm (in)

D Markings for bores, DN 50 flange

A0038762

10.2 Service-specific accessories

Ball valve for rinse chamber

- As rinse connection complementing or replacing the vent cock supplied;
- Order No. 51512982

O-ring set

- Viton + FPM
- Order No. 51512981

11 Technical data

11.1 Environment

Ambient temperature range 0 to 50 °C (32 to 122 °F)

11.2 Process

Medium temperature 0 to 85 °C (32 to 185 °F)

Medium pressure Max. 10 bar (145 psi)

i For manual insertion/retraction of the assembly, the medium pressure must not exceed 2 bar (29 psi)! Also take the process conditions of the sensor used into consideration!

Pressure/temperature ratings

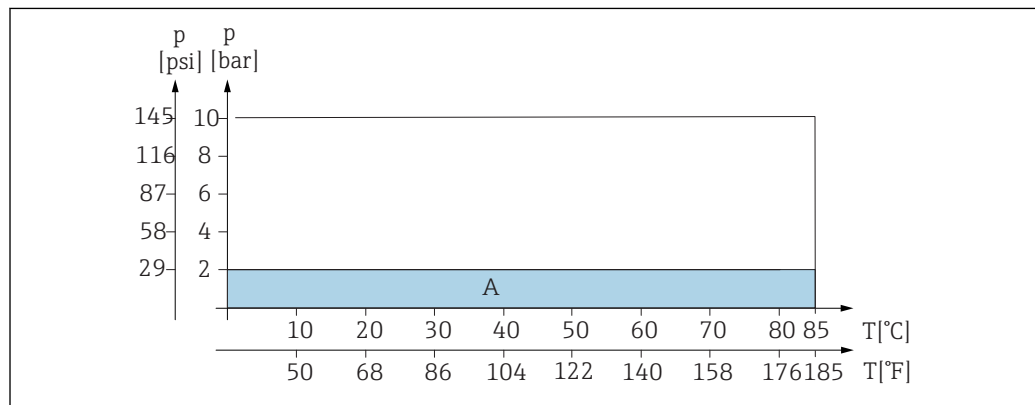

i 17 Pressure/temperature ratings

A Range in which the assembly can be operated manually

11.3 Mechanical construction

Dimensions → Section "Installation"

Rinse connection nozzles

Connection options:

- 2 x ball valve with hose connection OD 9mm (see "Accessories"). (A ball valve is included in the delivery for the assembly. On its own it acts as a vent cock.)
- Customer's own rinse connections with G1/8 external thread
- 2 x G1/8 (internal)

Vent cock

Ball valve with hose connection OD 9 mm

Weight Depending on version: 8 to 11 kg (17.6 to 24.3 lbs)

Materials

Wetted:	Viton (seals)
	Stainless steel 1.4404 (AISI 316 L)
	Nickel-plated brass (vent cock or rinse connection)
Not wetted:	Stainless steel 1.4404 (AISI 316 L)

Index

A

Ambient temperature range	40
Approvals	10

C

Certificates	10
------------------------	----

D

Designated use	5
Dimensions	40

M

Materials	41
---------------------	----

N

Nameplate	9
---------------------	---

O

Operational safety	6
------------------------------	---

P

Product identification	9
----------------------------------	---

R

Requirements for the personnel	5
--	---

S

Safety	
Operation	6
Workplace safety	5
Scope of delivery	10
Symbols	4

T

Technical data	
Environment	40
Mechanical construction	40
Technical personnel	5

U

Use	
Designated	5

W

Warnings	4
Weight	40
Workplace safety	5



71429362

www.addresses.endress.com
