



Level



Pressure



Flow



Temperature



Liquid  
Analysis



Registration



Systems  
Components



Services



Solutions

## Operating Instructions

# Stamolys CA71AM

Analyzer for the photometric determination of ammonium

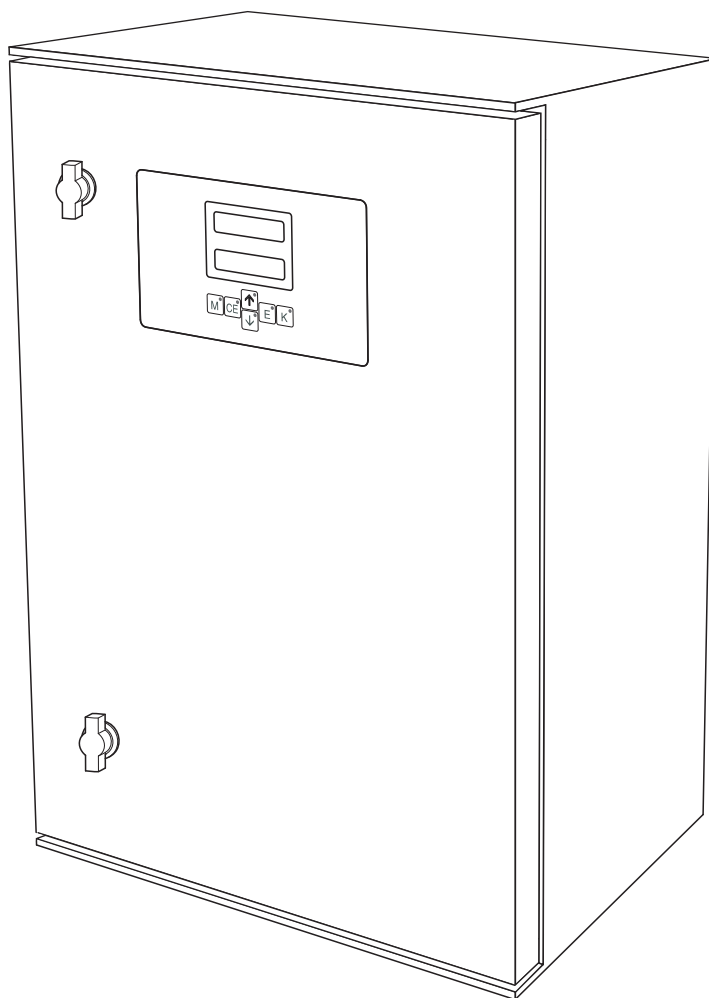

BA00353C/07/EN/14.12  
71162873

Valid of:  
Software version 6.3

## Brief overview

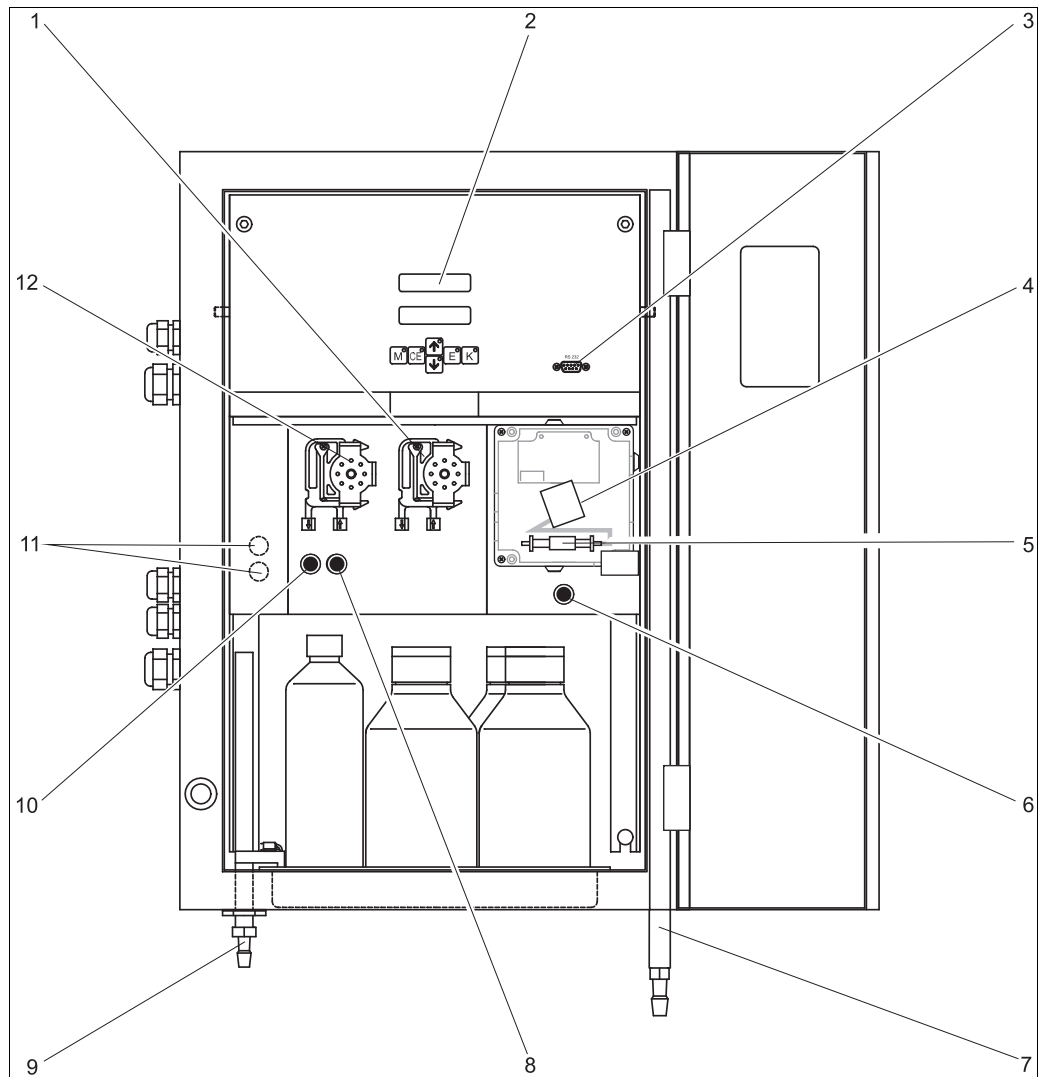

Fig. 1: Analyser (Schrankschrankausführung, ohne Schläuche)

1	Reagent pump (P2), supply from canister	7	Outlet (only CA71AM-D)
2	Display	8	Valve V2
3	Serial interface RS232	9	Outlet (only CA71AM-A/B/C)
4	Photometer cell	10	Valve V1
5	Static mixer (depending on version)	11	Channel switchover: top ch. 1, bottom ch. 2 <sup>1)</sup>
6	Valve V4 (nur CA71AM-D)	12	Sample pump P1, supply see below

1) Only for two-channel version

Inlet to the sample pump:

- Valve V1
  - hose in front: sample inlet
  - hose at the back: inlet from valve V2 (cleaner or standard solution)
- Valve V2
  - hose in front: inlet from canister with standard solution
  - hose at the back: inlet from canister with cleaner

## Table of contents

<b>1</b>	<b>Safety instructions</b>	<b>4</b>	<b>8</b>	<b>Accessories</b>	<b>47</b>
1.1	Designated use	4	8.1	Collecting vessel	47
1.2	Installation, commissioning and operation	4	8.2	Reagents, cleaner, standard solutions	47
1.3	Operational safety	4	8.3	Maintenance kit	47
1.4	Notes on safety icons and symbols	5	8.4	Hose cleaner	48
<b>2</b>	<b>Identification</b>	<b>6</b>	8.5	Dilution module	48
2.1	Device designation	6	8.6	Additional accessories	48
2.2	Scope of delivery	7	<b>9</b>	<b>Trouble-shooting</b>	<b>49</b>
2.3	Certificates and approvals	8	9.1	Trouble-shooting instructions	49
<b>3</b>	<b>Installation</b>	<b>9</b>	9.2	System error messages	49
3.1	Incoming acceptance, transport, storage	9	9.3	Process errors without messages	50
3.2	Installation conditions	9	9.4	Spare parts	51
3.3	Installation instructions	13	9.5	Software history	53
3.4	Installation examples	15	9.6	Return	55
3.5	Post-installation check	16	9.7	Disposal	55
<b>4</b>	<b>Wiring</b>	<b>17</b>	<b>10</b>	<b>Technical data</b>	<b>56</b>
4.1	Electrical connection	17	10.1	Input	56
4.2	Signal connection	21	10.2	Output	56
4.3	Switching contacts	22	10.3	Power supply	57
4.4	Serial interface	23	10.4	Performance characteristics	57
4.5	Post-connection check	24	10.5	Installation	58
<b>5</b>	<b>Operation</b>	<b>25</b>	10.6	Environment	59
5.1	Display and operating elements	25	10.7	Process	59
5.2	Local operation	25	10.8	Mechanical construction	59
5.3	Modbus RS485	32	<b>11</b>	<b>Appendix</b>	<b>60</b>
5.4	Calibration	33	11.1	Operating matrix	60
<b>6</b>	<b>Commissioning</b>	<b>35</b>	11.2	Maintenance schedule	64
6.1	Function check	35	<b>Index</b>	<b>65</b>	
6.2	Switch-on	35			
<b>7</b>	<b>Maintenance</b>	<b>40</b>			
7.1	Maintenance schedule	40			
7.2	Replacing reagents	41			
7.3	Replacing pump hoses	42			
7.4	Replacing valve hoses	44			
7.5	Replacing the static mixer	45			
7.6	Replacing the photometer optical cell	45			
7.7	Cleaning	46			
7.8	Placing out of service	46			

# 1 Safety instructions

## 1.1 Designated use

The analyzer is a compact photometric analysis system.

It is designed for the almost continuous monitoring of the ammonium content in wastewater and process media.

In particular, CA71 is designated for:

- Monitoring and optimizing the cleaning capacity of sewage treatment plants
- Monitoring activated sludge basins
- Monitoring sewage treatment plant outlets
- Potable water treatment
- Monitoring of industrial wastewater

Any other use than the one described here compromises the safety of persons and the entire measuring system and is not permitted.

The manufacturer is not liable for damage caused by improper or non-designated use.

## 1.2 Installation, commissioning and operation

Please note the following items:

- Installation, commissioning, operation and maintenance of the measuring system must only be carried out by trained technical personnel.  
Trained personnel must be authorized for the specified activities by the system operator.
- Electrical connection must only be carried out by a certified electrician.
- Technical personnel must have read and understood these Operating Instructions and must adhere to them.
- Before commissioning the entire measuring point, check all the connections. Ensure that electrical cables and hose connections are not damaged.
- Do not operate damaged products and secure them against unintentional commissioning.  
Mark the damaged product as being defective.
- Measuring point faults may only be rectified by authorized and specially trained personnel.
- If faults can not be rectified, the products must be taken out of service and secured against unintentional commissioning.
- Repairs not described in these Operating Instructions may only be carried out at the manufacturer's or by the service organization.

## 1.3 Operational safety

The analyzer has been designed and tested to the highest standards and left the factory in perfect functioning order.

Relevant regulations and European standards have been met.

As the user, you are responsible for complying with the following safety conditions:



- Installation instructions
- Local prevailing standards and regulations.

## 1.4 Notes on safety icons and symbols

The structure, signal words and safety colors of the signs comply with the specifications of ANSI Z535.6 ("Product safety information in product manuals, instructions and other collateral materials").

Safety message structure	Meaning
<p><b>▲ DANGER</b>  <b>Cause (/consequences)</b>            Consequences if safety message is not heeded            ► Corrective action</p>	<p>This symbol alerts you to a dangerous situation. Failure to avoid the situation <b>will</b> result in a fatal or serious injury.</p>
<p><b>▲ WARNING</b>  <b>Cause (/consequences)</b>            Consequences if safety message is not heeded            ► Corrective action</p>	<p>This symbol alerts you to a dangerous situation. Failure to avoid the situation <b>can</b> result in a fatal or serious injury.</p>
<p><b>▲ CAUTION</b>  <b>Cause (/consequences)</b>            Consequences if safety message is not heeded            ► Corrective action</p>	<p>This symbol alerts you to a dangerous situation. Failure to avoid this situation can result in minor or medium injury.</p>
<p><b>NOTICE</b>  <b>Cause/situation</b>            Consequences if safety message is not heeded            ► Action/note</p>	<p>This symbol alerts you to situations that can result in damage to property and equipment.</p>

### 1.4.1 Document symbols

-  1 This symbol indicates a cross reference to a defined page (e.g. p. 1).
-  2 This symbol indicates a cross reference to a defined figure (e.g. fig. 2).

## 2 Identification

### 2.1 Device designation

#### 2.1.1 Nameplate

Compare the (extended) order code on the nameplate (on the analyzer) to the product structure and your order.

You can read the following information from the nameplate:

- Order code
- Extended order code (=order code from the product structure)
- Serial number
- Measuring range
- Outputs and communication
- Power supply
- Ingress protection
- Environment conditions

#### 2.1.2 Order code and device version

Access the product page by entering the following address in your internet browser:  
[www.products.endress.com/ca71am](http://www.products.endress.com/ca71am)

1. You can choose from the following options on the product page located on the right:

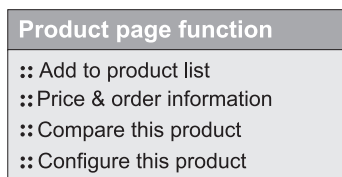

2. Click "Configure this product".
3. The configurator opens in a separate window.  
Use the radio buttons to configure the order code from the nameplate of your device.
4. Afterwards, you can export the order code as a PDF or Excel file.  
To do so, click the appropriate button at the top of the page.

## 2.2 Scope of delivery

- i** Order reagents separately with analyzer version CA71XX-XXXXXX1.  
With all other versions, inactive reagents are included in the scope of delivery. You have to mix the reagents before using them. Please, read the instructions attached to the reagents.

### 2.2.1 Version CA71AM-A/B/C

The scope of delivery comprises:

- An analyzer with mains plug
- A cleaning injector
- A tube of silicone grease
- A NORPRENE hose, length 2.5 m (8.2 ft), ID 1.6 mm (0.06 inch)
- A C-FLEX hose, length 2.5 m (8.2 ft), ID 6.4 mm (0.25 inch)
- A C-FLEX hose, length 2.5 m (8.2 ft), ID 3.2 mm (0.13 inch)
- Two hose fittings of each size:
  - 1.6 mm x 1.6 mm (0.06 inch x 0.06 inch)
  - 1.6 mm x 3.2 mm (0.06 inch x 0.13 inch)
  - 6.4 mm x 3.2 mm (0.25 inch x 0.13 inch)
- Two T-hose fittings of each size:
  - 1.6 mm x 1.6 mm x 1.6 mm (0.06 inch x 0.06 inch x 0.06 inch)
  - 3.2 mm x 3.2 mm x 3.2 mm (0.13 inch x 0.13 inch x 0.13 inch)
  - 6.4 mm x 6.4 mm x 6.4 mm (0.25 inch x 0.25 inch x 0.25 inch)
- An interference suppressor for the current output
- Four edge covers (version with GFR housing only)
- A roll of PTFE strip
- A quality certificate
- Operating Instructions (English).

### 2.2.2 Version CA71AM-D

The scope of delivery comprises:

- An analyzer with mains plug
- A cleaning injector
- A tube of silicone grease
- A NORPRENE hose, length 2.5 m (8.2 ft), ID 1.6 mm (0.06 inch)
- A Grifflex hose, length 2.0 m (6.6 ft), ID 19 mm (0.75 inch)
- A C-FLEX hose, length 2.5 m (8.2 ft), ID 3.2 mm (0.13 inch)
- A C-FLEX hose, length 2.5 m (8.2 ft), ID 6.4 mm (0.25 inch)
- Two hose fittings of each size:
  - 1.6 mm x 1.6 mm (0.06 inch x 0.06 inch)
  - 1.6 mm x 3.2 mm (0.06 inch x 0.13 inch)
  - 6.4 mm x 6.4 mm (0.25 inch x 0.25 inch, version without housing only)
- Two T-hose fittings of each size:
  - 1.6 mm x 1.6 mm x 1.6 mm (0.06 inch x 0.06 inch x 0.06 inch)
  - 3.2 mm x 3.2 mm x 3.2 mm (0.13 inch x 0.13 inch x 0.13 inch)
- An interference suppressor for the current output
- A nozzle for outlet pipe, ID 16 mm (0.63 inch)
- A hose clamp
- Two pipe clamps (version without housing only)
- A screwed socket for the outlet pipe
- Four edge covers
- A roll of PTFE strip
- A quality certificate
- Operating Instructions (English).

## 2.3 Certificates and approvals

### 2.3.1 CE approval

#### **Declaration of conformity**

The product meets the requirements of the harmonized European standards. It thus complies with the legal requirements of the EC directives.

The manufacturer confirms successful testing of the product by affixing the CE symbol.

### 2.3.2 Manufacturer certificate

#### **Quality certificate**

With the certificate the manufacturer confirms compliance with all technical regulations and the successful testing individually for your product.





Version with GFR housing, CA71AM-A/B/C

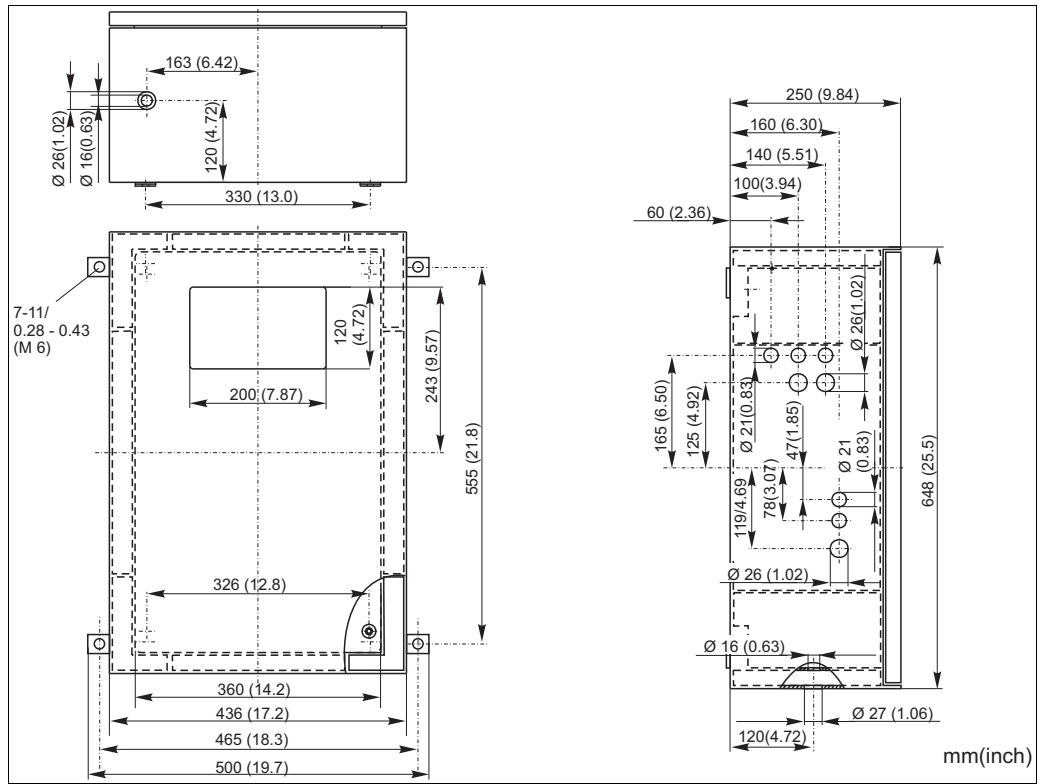

Fig. 3: GFR version

Version with GFR housing, CA71AM-D

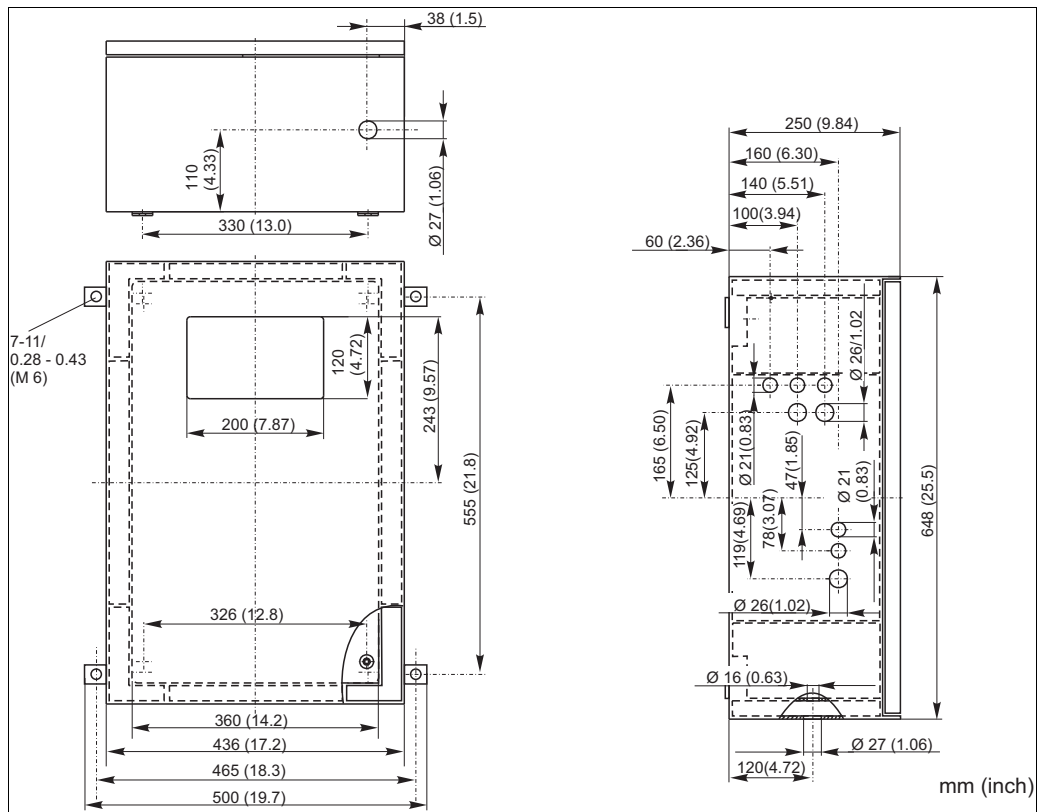

Fig. 4: GFR version

**Open version**

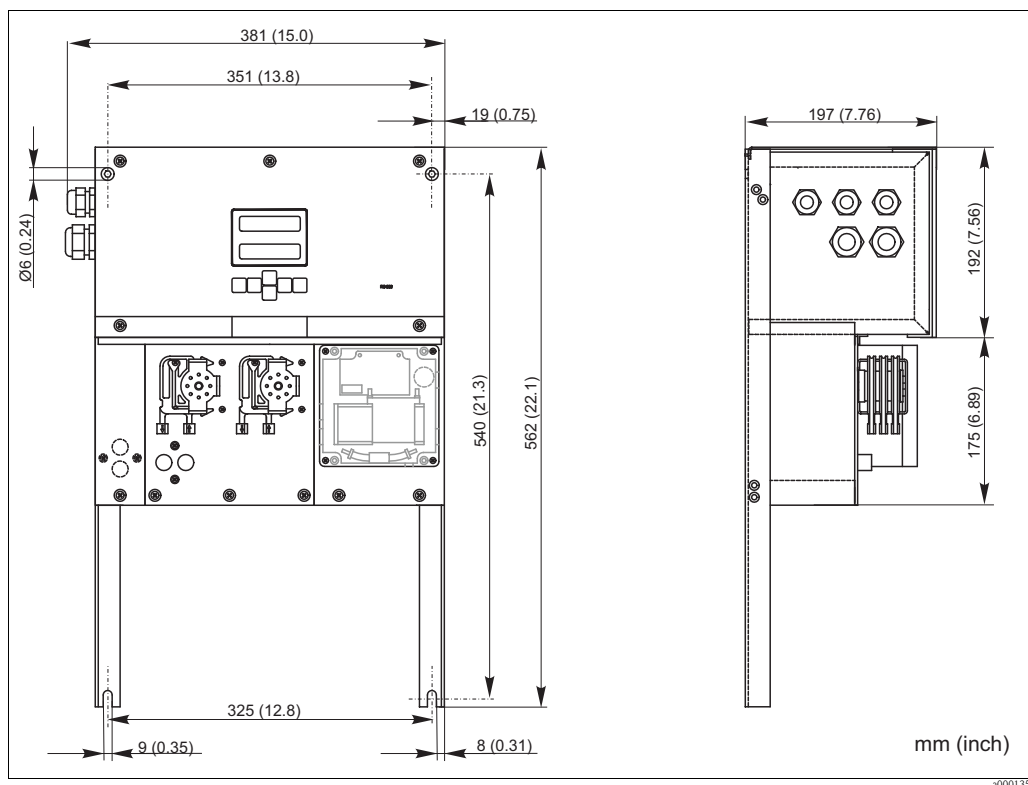

Fig. 5: Open version (without housing)

With the open version, you need an additional platform for the reagents. Mount this platform max. 35 cm (13.8 inch) below the pumps. The reagent bottles have the following dimensions: 90 x 90 x 215 mm (3.54 x 5.54 x 8.46 inch). The number of bottles varies from 2 to 5 depending on the analyzer version.

For these versions, the outlet pipe must be installed right of the analyzer. The outlet pipe must be mounted to a wall so that the sample outlet hoses from the photometer have a gradient of 5 to 10 %. If necessary, extend the hoses.

### 3.2.2 Connecting the sample line

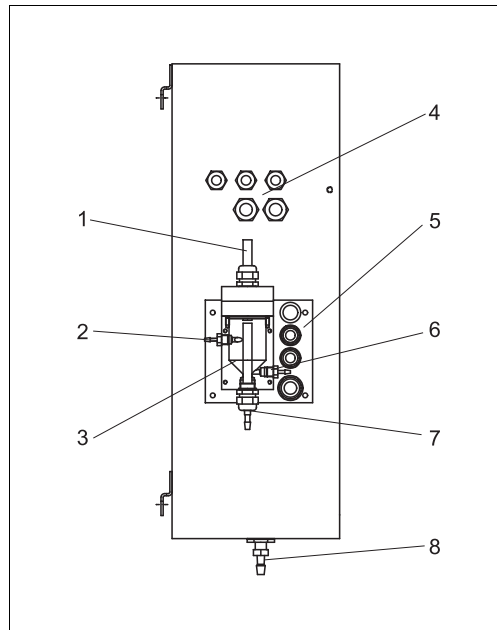

Fig. 6: Collecting vessel at analyzer (optional)

- 1 Ventilation
- 2 Sample inlet from sampling
- 3 Collecting vessel
- 4 Electrical connections
- 5 Analyzer sample inlet

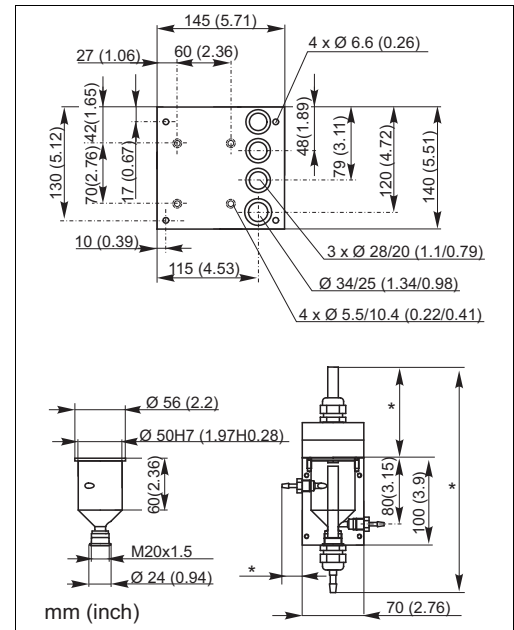

Fig. 7: Collecting vessel dimensions

- \* variable, freely adjustable dimensions
- 6 Sampling for analyzer
- 7 Sample overflow
- 8 Analyzer outlet

#### One-channel version

*Collecting vessel* (at analyzer, with or without level measurement)

Connection hose ID 3.2 mm (1/8 inch)

*Customer collecting vessel*

Connection hose ID 1.6 mm (1/16 inch)

Max. distance from collecting vessel to analyzer 1 m (3.3 ft)



Max. height difference from collecting vessel to analyzer 0.5 m (1.6 ft)

#### Two-channel version

- Depending on the ordered version, one or two collecting vessels (with or without level measurement) are included in the scope of delivery.
- Level measurement is only possible for one channel.
- Only one collecting vessel can be mounted at the housing. The second is to be placed nearby the analyzer.

### Adjusting the level measurement (one-channel version only)

Adjust the conductive level measurement due to the number of connected analysers.

1. In dependence of the application, mount the right adjusting pin or no adjusting pin (→  8 and →  9, position 2).
2. To receive an optimum sample volume, pull the marked pipe (position 3) downwards due to your application (1, 2 or 3 analysers).

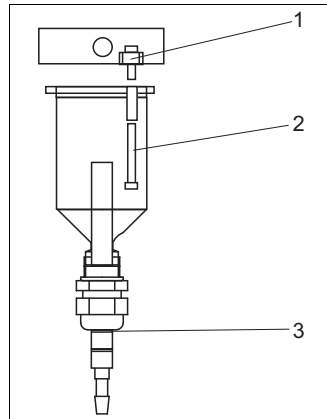

Fig. 8: One analyser

- 1 M 3x12 (0.47")
- 2 M 3x35 (1.38")
- 3 Mark 1

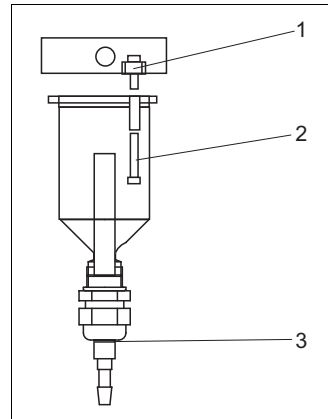

Fig. 9: Two analysers

- 1 M 3x12 (0.47")
- 2 M 3x20 (0.79")
- 3 Mark 2

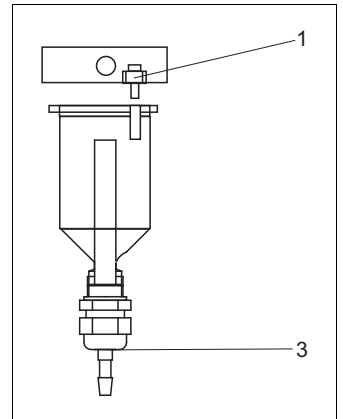



Fig. 10: Three analysers

- 1 M 3x12 (0.47")
- 3 Mark 3

## 3.3 Installation instructions

To install the analyzer at the intended location, proceed as follows:

1. Mount the analyzer and secure it to a vibration-free wall using screws ( $\varnothing 6$  mm / 0.24"). The fastening clips on the housing make sure that the necessary distance to the wall is observed for ventilation purposes.  
For the installation dimensions, please see the previous chapter.
2. Using a spirit level, check that the cabinet is hanging straight. Only in this way can any air bubbles present escape from the cell.
3. Fit the edge covers (with GFR housing only).
4. Lay the drain pipe for the reaction products. Where possible, use solid pipes (PE, internal diameter 1" with 3% incline).
5. Screw the screw-in connector ID 16 into the outlet pipe from below. Secure the Grifflex hose ID 19 to the nozzle with a hose clip (only CA71AM-D).
6. Insert the valve hoses accordingly. These were partly removed from the valves for transportation. This prevents the hoses from sticking or pressure being applied to a point in the hose over an extended period.  
CA71AM-A/B/C →  11  
CA71AM-D →  12

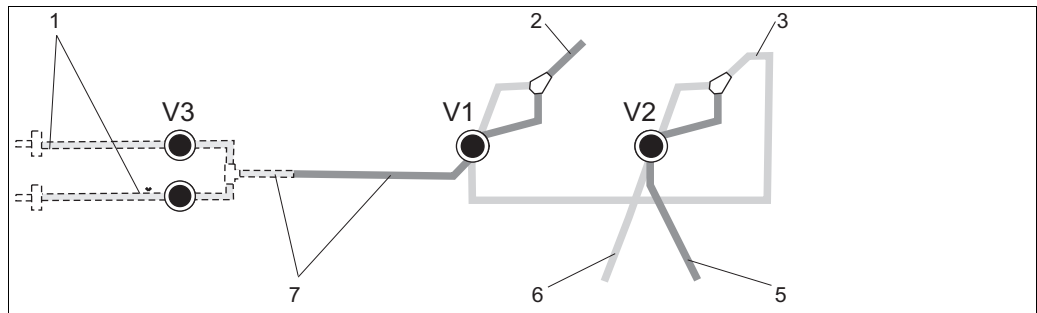

Fig. 11: Valves and valve hoses CA71AM-A/B/C

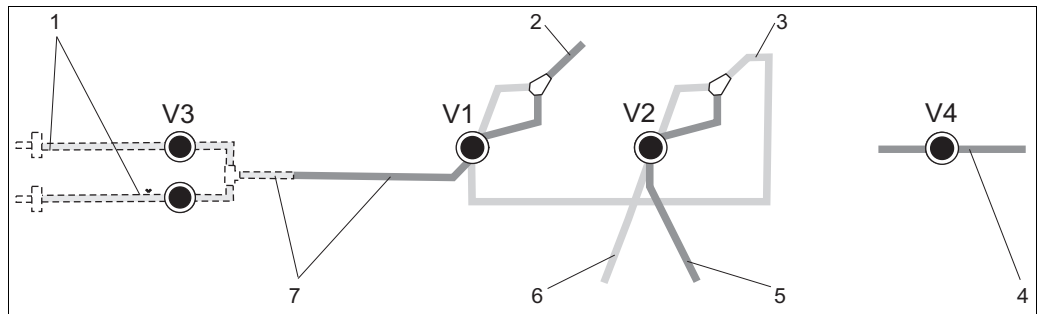

Fig. 12: Valves and valve hoses CA71AM-D

- |      |                                     |   |                                  |
|------|-------------------------------------|---|----------------------------------|
| V1-4 | Valves                              | 4 | Outlet hose                      |
| 1    | Channel switchover                  | 5 | Hose, valve 2 at front, standard |
| 2    | To sample pump                      | 6 | Hose, valve 2 at rear, cleaner   |
| 3    | Connecting hose to valve 1, at rear | 7 | Hose, valve 1 at front, sample   |

7. Secure the hose boxes in the appropriate pump holders:  
 Sample pump, left, reagent pump, right. The direction of flow of the sample and reagent must be counterclockwise.

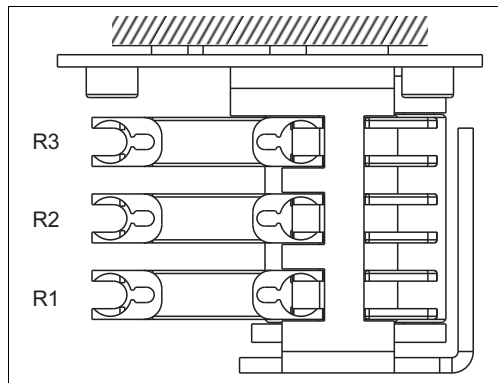

Fig. 13: Reagent pump, top view

- R1 Reagent 1
- R2 Reagent 2 (if present)
- R3 Reagent 3 (if present)

8. Connect the sample supply.

**The sample can be obtained as follows:**

- Directly or via a reversible flow filter or a cross-flow filter by means of a small pump (rating approx. 300 ml/min), suitable for clear media, e.g. in the outlet of a sewage treatment plant
- From microfiltration; this is practical for media containing flocculants, e.âg. in an activated sludge basin
- Sample conditioning using ultrafiltration for contaminated media, e.âg. from the primary settling tank.

**i** For questions regarding sample conditioning and its automation, please contact Service or the sales center responsible for your region.

9. Connect the tubes from canisters containing reagents, standards and cleaner to the following nozzles:

Canister	Tube designation (mark)
Sample	P
Reagent 1	AM1
Reagent 2	AM2
Standard solution	S
Cleaner	R

### 3.4 Installation examples

#### 3.4.1 CAT430 or customer-specific ultra filtration and two CA71 analyzers

- Permeate can contain air bubbles (CAT430) or is free of bubbles (customer-supplied ultrafiltration)
- Distance between the analysers as short as possible: sampling line between T-piece and the second analyser (→  14, item 2) shorter than 1.5 m
- Cross-section of sampling line ID 3.2 - 4 mm
- Only one sample receiver required

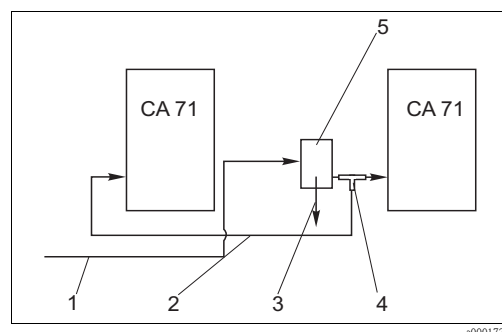

Fig. 14: Installation example

- 1 Sample from CAT430
- 2 Sampling line
- 3 Sample receiver overflow
- 4 T-piece
- 5 Collecting vessel

**NOTICE**

**Measuring errors due to missing sample**

- ▶ Ensure that there is always sufficient sample available for both analysers.
- ▶ Observe this when selecting maintenance intervals for CAT430 and when setting the buffer volume on the collecting vessel.

#### 3.4.2 CAT411, CAT430 and two CA71 analyzers (two-channel version)

- Permeate not free of air bubbles
- Distance between the analysers as short as possible: sampling line between T-piece and the second analyser (→  15, item 5) shorter than 1.5 m
- Cross-section of sampling line ID 3.2 - 4 mm
- One sample receiver each (**without level measurement**) for CAT411 or CAT430

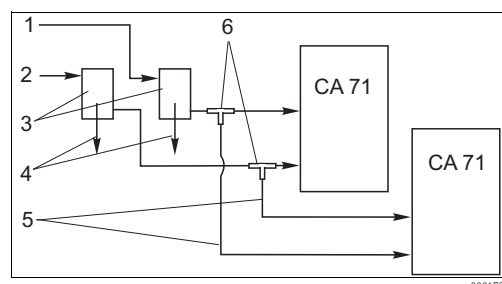

Fig. 15: Installation example

- 1 Sample from CAT430
- 2 Sample from CAT411
- 3 Collecting vessel
- 4 Collecting vessel overflow
- 5 Sampling lines
- 6 T-pieces

**NOTICE**

**Measuring errors due to missing sample**

- ▶ Ensure that there is always sufficient sample available for both analysers.
- ▶ Observe this when selecting maintenance intervals for CAT430 or CAT411 and when setting the buffer volume on the collecting vessel.

### **3.5 Post-installation check**

- After installation, check that all connections are fitted tightly and are leakage resistant.
- Ensure that the hoses cannot be removed without effort.
- Check all hoses for damage.



## 4 Wiring

### ▲ WARNING

#### Device is energized

Improper connection can cause injury or death.

- ▶ The electrical connection must only be carried out by a certified electrician.
- ▶ Technical personnel must have read and understood the instructions in this manual and must adhere to them.
- ▶ **Prior to beginning** any wiring work, make sure voltage is not applied to any of the cables.

### 4.1 Electrical connection

#### 4.1.1 Quick wiring guide

### NOTICE

#### Reaching the terminal block and avoiding damage

- ▶ You have to fold out the frame of the analyzer to reach the terminal block.
- ▶ Beforehand, release the hoses from the outlet pipe.
- ▶ Connect the hoses again after folding the frame back in. Otherwise there is a danger of flooding.

Fold out the frame as follows:

1. Release the two bottom Allen screws (AF 6) by 3-4 rotations (→  16, item 1).
2. Unscrew the two upper Allen screws completely so that the frame folds out. In this way, you reach the terminal block (item 2).

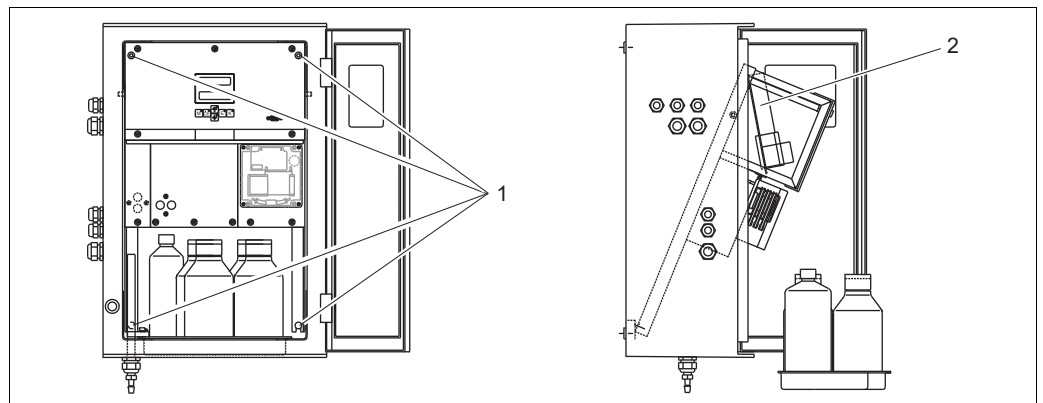

Fig. 16: Folding out the frame

- 1 Allen screws AF 6
- 2 Terminal strip

### NOTICE

#### The device does not have a mains switch

- ▶ Install the device near to a fused socket which is easy to reach.

### 4.1.2 Terminal assignment

**⚠ CAUTION**

Shown diagram (→ ) is an example

The terminal assignment and cable colors can deviate from the actual assignment and colors!

- ▶ Only use the terminal assignment of the sticker **in the device** (→ ) to connect your analyzer!

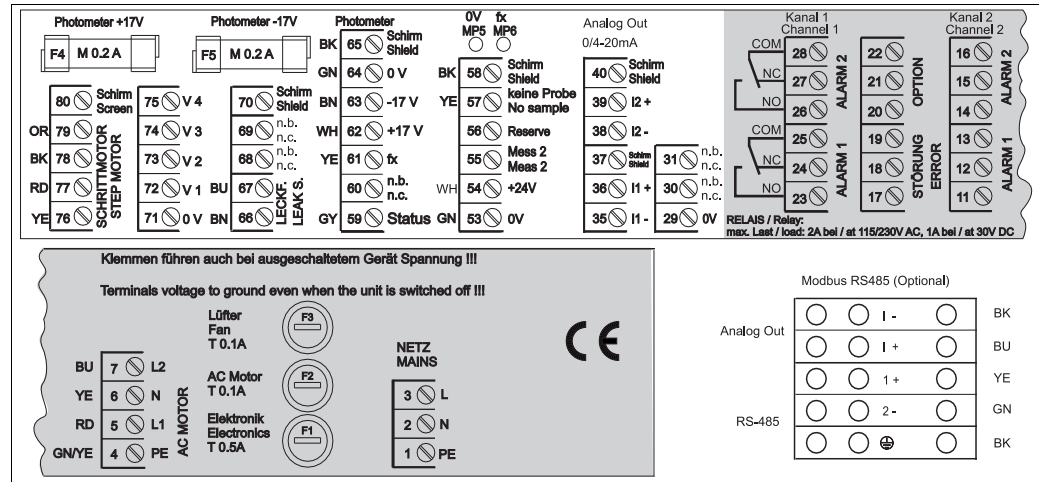

Fig. 17: Example of the connection sticker

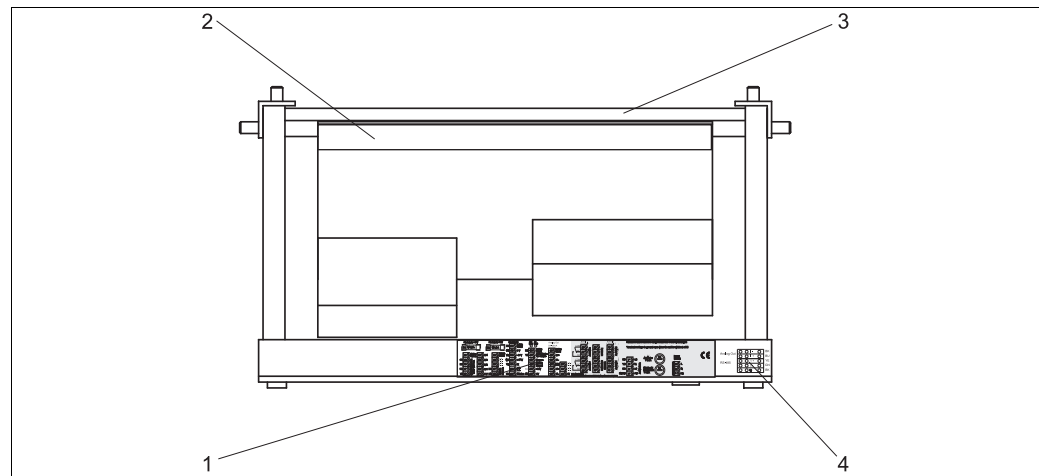

Fig. 18: Analyzer from top (open version resp. folded out)

- 1 Connection department sticker
- 2 Printed circuit board with terminal strip
- 3 Backside of the analyzer
- 3 Connection department sticker for Modbus RS485 (optional)

**Version without Modbus**

Function	Designation	Terminal one channel	Terminal two channels
Mains	L	3	3
	N	2	2
	PE	1	1
Alarm value 1, channel 1	COM	25	25
	NC	24	24
	NO	23	23
Alarm value 2, channel 1	COM	28	28
	NC	27	27
	NO	26	26
Alarm value 1, channel 2	COM	–	13
	NC	–	12
	NO	–	11
Alarm value 2, channel 2	COM	–	16
	NC	–	15
	NO	–	14
Fault	COM	19	19
	NC	18	18
	NO	17	17
Reserve (unassigned terminals)	COM	22	22
	NC	21	21
	NO	20	20
Analog output 1 0/4 ... 20 mA	+	36	36
	–	35	35
	Shield	PE <sup>1</sup>	PE <sup>1</sup>
Analog output 2 0/4 ... 20 mA	+	–	39
	–	–	38
	Shield	–	PE <sup>1</sup>
Sample conditioning remote control	Input	57	57
	0 V	53	53
Channel switch-over	Input	–	55
	0 V	–	53

1) Brass screw with bolt top right in the connection compartment (marked with ⊕)

**Version with Modbus RS485**

Function	Designation	Terminal one channel
Mains	L	3
	N	2
	PE <sup>1)</sup>	1
Alarm value 1	COM	25
	NC	24
	NO	23
Alarm value 2	COM	28
	NC	27
	NO	26
Fault	COM	19
	NC	18
	NO	17
Reserve (unassigned terminals)	COM	22
	NC	21
	NO	20
Analog output 1 0/4 ... 20 mA <sup>2)</sup>	+	I +
	-	I -
	Shield	⊖
Modbus RS485 <sup>3)</sup>	+	1 +
	-	2 -
Sample conditioning remote control	Input	57
	0 V	53

- 1) Brass screw with bolt top right in the connection compartment (marked with ⊖)
- 2) At Modbus module terminals
- 3) The Modbus module is already installed and wired up at the factory.

**NOTICE****Terms for special terminals**

- ▶ Limit switches 1 and 2 do not need to be connected if the PLC sets its own alarm values at the analog output.
- ▶ When using a sample conditioning system: Connect terminals 57 and 53 on the analyzer to the corresponding terminals on the sample conditioning system. For the allocation of these terminals see the sample conditioning system operating instructions.
- ▶ If there is a 24 V voltage at terminal 57, the analyzer will not begin measurement (sample not ready). To start measurement, the voltage must stay at 0 V for at least 5 seconds.
- ▶ All external relay contacts have to be connected to 230 V.

## 4.2 Signal connection

### 4.2.1 Screening of the analog outputs

The interference suppressor attenuates electromagnetic effects on control, power and signal lines. After the connection of the data transfer cables clip the interference suppressor (in scope of delivery) on the cable cores (not on the outer insulation of the cable!). Place the cable screen out of the interference suppressor and connect it to PE (brass screw with bolt, top right in the connection compartment) (→  19).

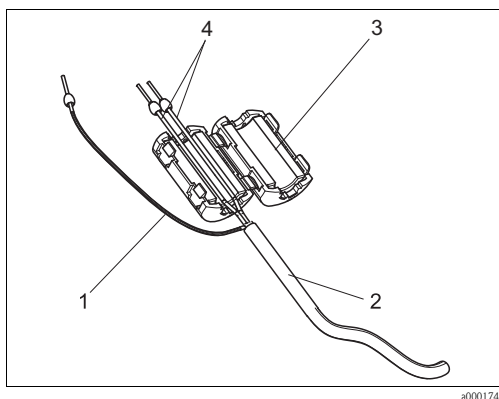

Fig. 19: Interference protection of the signal cable

- 1 Cable screen (to PE )
- 2 Signal cable
- 3 Interference suppressor
- 4 Cable cores of the signal cable

 With the two-channel version, place the cable cores of all cables (data cables to analog output 1 and to analog output 2) through the interference suppressor.

### 4.2.2 One-channel version

Connection	Designation	Function
Signal inputs	Leak	Liquid has collected in the drip pan
	No sample	No sample available, measurement is not started, display flashes
Signal outputs	AV 1	Alarm value 1 exceeded or undershot
	AV 2	Alarm value 2 exceeded or undershot
	Fault	Retrieves error message using operation menu
	Measurement end	Displays "Measurement finished" (5 s)
Analog output	I-1 channel 1	0 or 4 mA = measuring range start 20 mA = measuring range end

### 4.2.3 Two-channel version

Connection	Designation	Function
Signal inputs	Leak	Liquid has collected in the drip pan
	No sample	No sample available, measurement is not started, display flashes
Signal outputs	AV 1-1	Alarm value 1, channel 1 exceeded or undershot
	AV 2-1	Alarm value 2, channel 1 exceeded or undershot
	AV 1-2	Alarm value 1, channel 2 exceeded or undershot
	AV 2-2	Alarm value 2, channel 2 exceeded or undershot
	Fault	Retrieves error message using operation menu
	Channel 1/2 or measurement end <sup>1)</sup>	Displays active channel Displays "Measurement finished" (5 s)
Analog output	l-1 channel 1	0 or 4 mA = measuring range start 20 mA = measuring range end
	l-2 channel 2	0 or 4 mA = measuring range start 20 mA = measuring range end
Channel selection	Meas. 2	0 V = channel 1 24 V = channel 2

1) Alternative selection

## 4.3 Switching contacts

### One-channel version

Connection	Terminal connection for condition fulfilled	Terminal connection for condition not fulfilled	Terminal connection for power off
AV 1	A: 25 - 23 R: 25 - 24	A: 25 - 24 R: 25 - 23	25 - 24
AV 2	A: 28 - 26 R: 28 - 27	A: 28 - 27 R: 28 - 26	28 - 27
Fault	A: 19 - 17 R: 19 - 18	A: 19 - 18 R: 19 - 17	19 - 18
Unassigned	22 - 20 16 - 14 13 - 11	22 - 21 16 - 15 13 - 12	22 - 21 16 - 15 13 - 12
A = NO current configured R = NC current configured			

**Two-channel version**

Connection	Terminal connection for condition fulfilled	Terminal connection for condition not fulfilled	Terminal connection for power off
AV 1 - 1	A: 25 - 23 R: 25 - 24	A: 25 - 24 R: 25 - 23	25 - 24
AV 1 - 2	A: 13 - 11 R: 13 - 12	A: 13 - 12 R: 13 - 11	13 - 12
AV 2 - 1	A: 28 - 26 R: 28 - 27	A: 28 - 27 R: 28 - 26	28 - 27
AV 2 - 2	A: 16 - 14 R: 16 - 15	A: 16 - 15 R: 16 - 14	16 - 15
Fault	A: 19 - 17 R: 19 - 18	A: 19 - 18 R: 19 - 17	19 - 18
Channel 1/2 measurement end	A: 22 - 20 R: 22 - 21	A: 22 - 21 R: 22 - 20	22 - 21
A = NO current configured R = NC current configured			

Condition fulfilled means:

- AV 1: concentration > Alarm value 1
- AV 2: concentration > Alarm value 2
- Fault: error occurred

 Contacts AV 1, AV 2 and fault are only affected during automatic operation.

**4.4 Serial interface**

RS 232 of CA71		COM 1/2 at PC	
SUB-D, nine-pin	Function	Function	SUB-D, nine-pin
3	TxD	RxD	2
2	RxD	TxD	3
8	CTS	RTS	7
		CTS	8
5	GND	GND	5
Software protocol:	9600 baud, 8 data bits, 1 stop bit, no parity (9600, N, 8, 1)		
Output format:	ASCII		

The results (measured value+unit of measure) are output in the "Data memory Measured values" menu.

The calibration results (measured value+unit of measure) are output in the "Data memory-Calibration factors" menu.

 A null modem cable is required (not a crossed one).  
The analyzer does not have to be configured for the interface.

The following commands can be sent from the PC, in order to read out data:

- "D" = Data memory-Measured values
- "C" = Data memory-Calibration factors
- "S" = Setup (parameter entry, configuration...)
- "F" = Frequency (current)

## 4.5 Post-connection check

Carry out the following checks after electrical connection:

Device status and specifications	Note
Is the analyser or cable externally undamaged?	Visual inspection

Electrical connection	Note
Does the supply voltage correspond to the data on the nameplate?	230 V AC / 50 Hz 115 V AC / 60 Hz
Are current outputs screened and connected?	
Are the mounted cables relieved of tension?	
Cable type properly disconnected?	Guide power supply and signal lines separately over the entire travel distance. Separate cable channels are ideal.
Cable routing without scuffing or cross-overs?	
Are power supply and signal lines connected correctly according to wiring diagram?	
Are all screw terminals tightened?	
Are all cable entries mounted, tightened and leak-resistant?	
Interference suppressor at the analogue output?	
Current output simulation	See procedure below

Current output test:

1. Hold both arrow keys down (see "Display and operating elements" chapter) and connect the analyser to the mains or switch the mains switch on (if available). Wait until the display "0 mA" appears.
2. Check on your PLC, PCS or you data logger whether the current value is the same.
3. Press the  key. Browse to the next current values (4, 12, 20 mA, depending on the setting).
4. Check that the respective current values are also on your PLC, PCS or your data logger.
5. If the values are not there:
  - a. Check the terminal assignment for analogue output 1 or 2.
  - b. Disconnect the analogue outputs from your PLC, PLS or your data logger and repeat steps 14 with the restriction that you measure the current values at the terminals of the analyser and not at the PLC, SPL or data logger.  
If these current values are correct, please check your PLC, SPL, the data logger or the electrical cables.



## 5 Operation

### 5.1 Display and operating elements

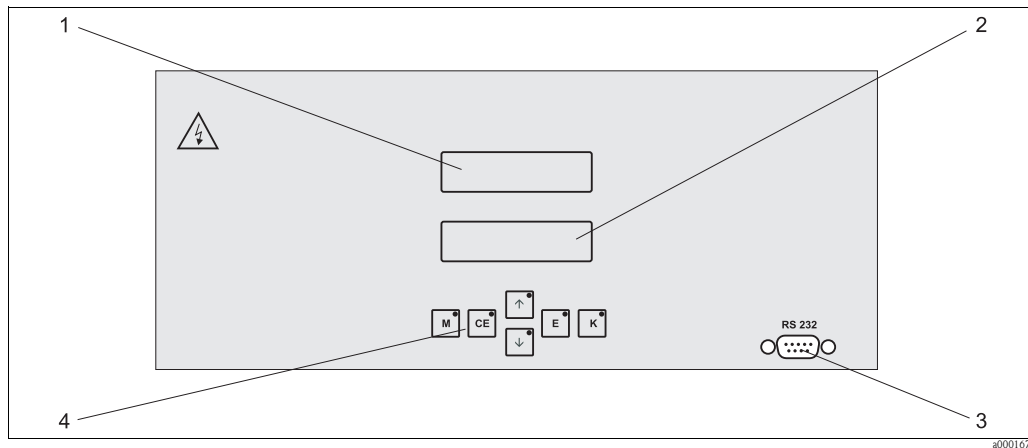

Fig. 20: Display and operating elements

- 1 LED (measured value)
- 2 LC display (measured value and status)
- 3 Serial interface RS 232
- 4 Operating keys and control LEDs

### 5.2 Local operation



The operating keys and the integrated indicator LEDs have the following functions:

Key	Key function	Indicator LED function
M	– “Auto measuring” option – back to the main menu from all sub-menus	Alarm value 1 exceeded
CE	– backwards in the sub-menu (horizontal, see Appendix)	Alarm value 2 exceeded
↑	– backwards in the main menu (vertical) – increase value	Measuring range exceeded
↓	– forwards in the main menu (vertical) – reduce value	Measuring range undershot
E	– select option – adopt value, forwards in the sub-menu (horizontal) <sup>1)</sup>	Retrieve error message
K	– selection in the sub-menu	Cleaning interval is running

1) By pressing the ↑ or ↓ and the E key simultaneously, you can set the digit after the decimal point.

### 5.2.1 Main menu

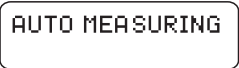
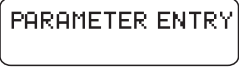
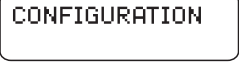
Access the main menu by holding down the  key until "AUTO MEASURING" is displayed. For the main menu options and information about them, please see the following table.

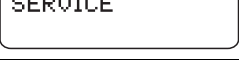
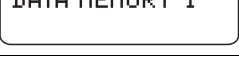
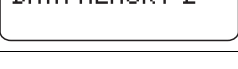
Selection	Display	Info
AUTO MEASURING		Calibration, measurement, flushing time-controlled actions
PARAMETER ENTRY		Default settings for measuring ranges, alarm values, calibration, rinsing
CONFIGURATION		Basic settings such as parameters, measuring units, arrangement of analog outputs and alarm values, date, time, offset values
LANGUAGE		Selecting menu language
ERROR DISPLAY		Displaying error messages
SERVICE		Manually switching valves and pumps
DATA MEMORY 1		Last 1024 measured values channel 1
DATA MEMORY 2 (Two-channel version only)		Last 1024 measured values channel 2

### 5.2.2 AUTO MEASURING

The actions "calibration", "measuring" and "flushing" are triggered by time-control. The respective action is displayed in the LC display. The most recently registered concentration value is displayed until the end of the next measurement.

Otherwise, "wait" is displayed when

- the time of the first measurement has not yet been reached or
- the measuring interval has not yet expired.



 "Measuring" flashes when the analyzer is ready for the next measurement but has not yet received the enable signal from the sample collector or the sample conditioning unit.

### 5.2.3 CONFIGURATION

Some settings that can be made in this menu affect the defaults in the PARAMETER ENTRY menu.

- ▶ Complete the CONFIGURATION menu first during initial start-up.

Menu item	Range of adjustment (factory settings in bold)	Display	Info
Code number	<b>03</b>	Code-No. ? 0	Input 03. If an incorrect code is entered the program exits the sub-menu.
Photometer	Depending on specification <b>AM-A</b> <b>AM-B</b> <b>AM-C</b> <b>AM-D</b>	Photometer AM-A	The setting displays the parameter that is being measured. This is defined by the product specification and set in this menu item at the factory. Do not change the value. Otherwise, you will receive an "Incorrect photometer" error message.
Default settings	Yes / no	default setup y: ↑↓ n: E	If "yes" is selected, all the settings are reset to the factory settings. You must set the current date and time (scroll through the menu, third-last point). In the event of a reset, the date for the 1st calibration and the 1st flush is set to the following day.
Measuring unit	AM-A/B/C: <b>mg/l</b> AM-D: <b>µg/l</b> ppm ppb	Unit of measure mg/l	The measuring unit selected depends on the type of photometer. This setting also affects the scope of the measuring range.
Calibration factor	0.10 to 10.00 <b>1.00</b>	Calibr. factor 1.00	The calibration factor is the ratio of the measured concentration of the calibration standard to the predefined concentration of the standard (see "PARAMETER ENTRY", calibration solution). The deviation results from factors such as reagent aging, aging of constructive components, etc. The calibration factor compensates for these effects. CA 71 checks the registered calibration factor logically. If the factor is outside of the error tolerance, the calibration is automatically repeated. If the value is still outside the tolerance range after repeating calibration, an error message appears and the analyzer continues to work with the most recently registered, logically correct factor. The last 100 calibration factors are stored in the memory with the date and time and can be retrieved by pressing the <b>[K]</b> key. The calibration factor can be changed manually. Optional dilution modules are taken into consideration in the calibration factor.
Concentration offset	<b>0.00</b> to 50.0 mg/l	c-Offset 0.00 mg/l	The offset gives users the option of adapting to an external comparison measurement. (Change the sign with the <b>[K]</b> key.)
Dilution	0.10 to 10.00 <b>1.00</b>	Dilution 1.00	If the sample is diluted externally between taking the sample and the analyzer, the dilution factor has to be entered here. If an optional dilution module is used, the factor remains 1. The dilution is taken into consideration by means of the calibration factor.
Delay to sample	20 to 300 s AM-A/B/C: <b>120 s</b> AM-D: <b>160 s</b>	Delay to sample 120 s	Dosing time for sample or standard. During this time, the entire system is flushed with sample or standard, so when the reagent is added there is definitely only fresh sample in the mixer. If sufficient sample is available, or in the event of an external collecting vessel with a long supply line, select the highest possible value.

Menu item	Range of adjustment (factory settings in bold)	Display	Info
Analog output 1	0 to 20 mA / <b>4 to 20 mA</b>	Analog output 1 4-20 mA	Selection for the measuring range scope for channel 1. If the concentration measuring range is 0 to x mg/l, either 4 mA or 0 mA corresponds to 0 mg/l. The end of the measuring range is the same in both cases at 20 mA.
Analog output 2		Analog output 2 4-20 mA	<b>Only two-channel version!</b> Selection for the measuring range scope for channel 2. The scopes of measuring range are independent of each other for channel 1 and channel 2 and are determined by the start of measuring range setting (channel 1 / channel 2) or end of measuring range setting (channel 1 / channel 2) in the PARAMETER ENTRY menu.
Alarm value AV 1-1	NO NC  Changes only take effect after a reset (power off/on)!	Alarm val. 1-1 norm. closed	Setting as to whether the contact for alarm value 1, channel 1 works as an NO or NC contact.
Alarm value AV 2-1		Alarm val. 2-1 1.25 mg/l	Setting as to whether the contact for alarm value 2, channel 1 works as an NO or NC contact.
Alarm value AV 1-2		Alarm val. 1-2 norm. closed	<b>Two-channel version only!</b> Setting as to whether the contact for alarm value 1, channel 2 works as an NO or NC contact.
Alarm value AV 2-2		Alarm val. 2-2 norm. closed	<b>Two-channel version only!</b> Setting as to whether the contact for alarm value 2, channel 2 works as an NO or NC contact.
Error contact		Error contact norm. closed	Setting as to whether the contact for the fault message works as an NO or NC contact.
Current date/time	01.01.96 00:00 to 31.12.95 23:59	act. Date/Time 25.01.02 15:45	Setting the system clock. Format DD.MM.YY hh:mm.
Calibrate offset	Yes / no	Calibrate offs yes:K no:E	Frequency offset <sup>1)</sup> Pressing the  key starts blank value measurement for compensating the reagent's inherent color.
Frequency offset <sup>1)</sup>	-5000 to +5000 <b>0</b>	f-Offset [Hz] 0	Manually changing the frequency offset. <sup>1)</sup>

- 1) Redetermine the frequency offset and the calibration factor every time the reagents are changed or the photometer is replaced. To do so, instead of sample connect deionized water to the sample inlet to determine the frequency offset (blank value). The value is generally between 0 and 10 Hz.

## 5.2.4 PARAMETER ENTRY

Menu item	Range of adjustment (factory settings in bold)	Display	Info
Measuring range start 1	AM-A: 0.1 to 5 mg/l / <b>0.00 mg/l</b> AM-B: 0.2 to 15 mg/l / <b>0.0 mg/l</b> AM-C: 0.2 to 100 mg/l / <b>0.0 mg/l</b> AM-D: 1 to 500 µg/l / <b>0.0 µg/l</b>	Range start 1 0.00 mg/l	The specified concentration is allocated a value of 0 or 4 mA at analog output 1 <sup>1)</sup> .
Measuring range start 2	AM-A: 0.1 to 5 mg/l / <b>0.00 mg/l</b> AM-B: 0.2 to 15 mg/l / <b>0.0 mg/l</b> AM-C: 0.2 to 100 mg/l / <b>0.0 mg/l</b> AM-D: 1 to 500 µg/l / <b>0.0 µg/l</b>	Range start 2 0.00 mg/l	<b>Only two-channel version!</b> The specified concentration is allocated a value of 0 or 4 mA at analog output 2.
Measuring range end 1	AM-A: 0.1 to 5 mg/l / <b>5.00 mg/l</b> AM-B: 0.2 to 15 mg/l / <b>15.0 mg/l</b> AM-C: 0.2 to 100 mg/l / <b>100.0 mg/l</b> AM-D: 1 to 500 µg/l / <b>500.0 µg/l</b>	Range end 1 5.00 mg/l	The specified concentration is allocated a value of 20 mA at analog output 1.
Measuring range end 2	AM-A: 0.1 to 5 mg/l / <b>5.00 mg/l</b> AM-B: 0.2 to 15 mg/l / <b>15.0 mg/l</b> AM-C: 0.2 to 100 mg/l / <b>100.0 mg/l</b> AM-D: 1 to 500 µg/l / <b>500.0 µg/l</b>	Range end 2 5.00 mg/l	<b>Only two-channel version!</b> The specified concentration is allocated a value of 20 mA at analog output 2.
Alarm value AV 1 - 1	AM-A: 0.1 to 5 mg/l / <b>2.50 mg/l</b> AM-B: 0.2 to 15 mg/l / <b>7.50 mg/l</b> AM-C: 0.2 to 100 mg/l / <b>30.0 mg/l</b> AM-D: 1 to 500 µg/l / <b>250.0 µg/l</b>	Alarm val. 1-1 2.50 mg/l	Concentration threshold value for limit relay 1, channel 1 (switching hysteresis 2% of alarm value).
Alarm value AV 2 - 1	AM-A: 0.1 to 5 mg/l / <b>5.00 mg/l</b> AM-B: 0.2 to 15 mg/l / <b>15.0 mg/l</b> AM-C: 0.2 to 100 mg/l / <b>50.0 mg/l</b> AM-D: 1 to 500 µg/l / <b>500.0 µg/l</b>	Alarm val. 2-1 5.00 mg/l	Concentration threshold value for limit relay 2, channel 1 (switching hysteresis 2% of alarm value).
Alarm value AV 1 - 2	AM-A: 0.1 to 5 mg/l / <b>2.50 mg/l</b> AM-B: 0.2 to 15 mg/l / <b>7.50 mg/l</b> AM-C: 0.2 to 100 mg/l / <b>30.0 mg/l</b> AM-D: 1 to 500 µg/l / <b>250.0 µg/l</b>	Alarm val. 1-2 2.50 mg/l	<b>Only two-channel version!</b> Concentration threshold value limit relay 1, channel 2 (switching hysteresis 2% of alarm value).
Alarm value AV 2 - 2	AM-A: 0.1 to 5 mg/l / <b>5.00 mg/l</b> AM-B: 0.2 to 15 mg/l / <b>15.0 mg/l</b> AM-C: 0.2 to 100 mg/l / <b>50.0 mg/l</b> AM-D: 1 to 500 µg/l / <b>500.0 µg/l</b>	Alarm val. 2-2 5.00 mg/l	<b>Only two-channel version!</b> Concentration threshold value limit relay 2, channel 2 (switching hysteresis 2% of alarm value).
Time 1. measurement	01.01.96 00:00 to 31.12.95 23:59	1. Measurement 10.02.02 08:00	Date format DD.MM.YY, time hh.mm. After each change the instrument does not wait for the measuring interval. If the measurement is to start immediately, set the time in the past.
Measuring interval	2 to 120 minutes <b>10 min</b>	Meas. interval 10 min	Time between two measurements. If the setting is 2 minutes, the measurements take place without any pauses.
Frequency of measurement Channel 1	0 to 9 <b>1</b> <sup>2)</sup>	n* Channel 1: 1	<b>Two-channel version only!</b> Number of measurements at channel 1 before switching to channel 2.
Frequency of measurement Channel 2	0 to 9 <b>1</b>	n* Channel 2: 1	<b>Two-channel version only!</b> Number of measurements at channel 2 before switching to channel 1.
Time 1. calibration	01.01.96 00:00 to 31.12.95 23:59	1. Calibration 01.01.02 08:00	Time of 1st calibration (DD.MM.YY, time hh.mm). After each change the instrument does not wait for the calibration interval. If the calibration is to start immediately, set the time in the past.  Analyzers are delivered pre-calibrated. – Start the 1st calibration 2 hours after the initial startup at the earliest (warm-up phase) – Set the time to 8:00 to track the effects of calibration in the curve. – If you have started a calibration manually, you should redefine the time of the 1st calibration because the interval is calculated starting from the last calibration.

Menu item	Range of adjustment (factory settings in bold)	Display	Info
Calibration interval	0 to 720 h <b>48 h</b>	Calib.interval 48 h	Time between two calibrations. The "0 h" setting means that calibration does not take place. Recommended: calibration interval of 48 to 72 h. The interval has to be shortened to 6 hours for temperatures > 30 °C!
Calibration solution	AM-A: 0.1 to 5 mg/l / <b>5.00 mg/l</b> AM-B: 0.2 to 15 mg/l / <b>5.00 mg/l</b> AM-C: 0.2 to 100 mg/l / <b>50.0 mg/l</b> AM-D: 1 to 500 µg/l / <b>100.0 µg/l</b>	Calib. solution 5.0 mg/l	Concentration of the calibration standard. Select a standard whose concentration is in the top third of the measuring range.
1. flushing	01.01.96 00:00 to 31.12.95 23:59	1. Flushing 01.01.02 08:10	Time of 1st flushing (DD.MM.YY, time hh.mm). After each change the instrument does not wait for the flushing interval. If the flushing is to start immediately, set the time in the past. – Set the time to 4:00 to track the effects of flushing in the curve. – If you have started flushing manually, you should redefine the time of the 1st flushing because the interval is calculated starting from the last flushing.
Flushing interval	0 to 720 h <b>48 h</b>	Flush. interval 48 h	Time between two flushings. The "0 h" setting means that cleaning no longer takes place.
Flushing hold on	0 to 60 s <b>60 s</b>	Flushing hold on 60 s	Dwell time of flushing solution in the pump-mixer-photometer line. Recommended: 30 to 60 s.

- 1) Option 0 or 4 mA: see "CONFIGURATION".
- 2) All channels set to 0 means that the channel is selected externally. All channels set to 1 means alternating, beginning with channel 1.

### NOTICE

#### Measuring errors due to contamination by cleaning agents

- ▶ Always coordinate calibration and flushing.
- ▶ Carry out flushing with standard cleaners approx. 3-4 hours **before** the next calibration.
- ▶ Flushing with special cleaners (e.g. hydrochloric acid or ammonia) has a lasting effect on calibration. Therefore, carry out this cleaning 3-4 hours **before** calibration. Then rinse with deionized water afterwards.

## 5.2.5 LANGUAGE

The following languages are available:

- Deutsch
- English
- Français
- Suomi
- Polski
- Italiano.
- Espanol

### 5.2.6 ERROR DISPLAY

- This menu is a "read-only menu".
- You can find the individual error messages, their meaning and solutions to problems in chapter "Trouble-shooting instructions".
- If there is at least one error message, the signal output is set to "fault".
- Causes of faults are requested for every measurement. If an error which occurred previously no longer exists, it is automatically cancelled.

### 5.2.7 SERVICE

**NOTICE**

**In this menu, you can trigger direct function controls. If these controls are incorrectly combined, however, this could damage the analyzer.**

- ▶ Using the Service menu requires detailed knowledge of how the analyzer works and operates.
- ▶ Exit the Service menu with the "M" key. All functions will be reset to the delivery state then.

Option	Display	Info
Pumps and valves		<p>"Virtual switching board" Various valve and pump combinations can be selected.</p> <p>The setting options are:</p> <ul style="list-style-type: none"> <li>- Valve 1: P (sample) or S (standard)</li> <li>- Valve 2: S (standard) or C (cleaning agent)</li> <li>- Valve 3 (<b>Two-channel version only</b>): 1 (channel 1) or 2 (channel 2)</li> <li>- Valve 4 (for optical cell outlet, improves cleaning and avoids memory effects): s (stop) or g (go)</li> <li>- Pump 1 (sample or standard/cleaner) and pump 2 (reagents): s (stop) or g (go)</li> <li>- Mixture The reagent and sample pumps can be switched on together, so that they run in the same ratio as for filling the sample-reagent mixture in measuring mode. s (stop) and g (go)</li> </ul> <p> P1 and P2 are inactive, when G is at go. If P1 or P2 is at go, G is not available.</p> <p>The following valve combinations are possible:(applies to one-channel and two-channel version, whereby where the latter is concerned selection is made by positioning valve 3 between channel 1 and 2)</p> <ul style="list-style-type: none"> <li>- V1: P, V2: S Passage for the sample. This combination is automatically reset on leaving the service menu.</li> <li>- V1: S, V2: S Passage for standard solution</li> <li>- V1: S, V2: R Passage for cleaning agent</li> </ul>
Signal frequency		Signal frequency of the photometer

### 5.2.8 DATA STORAGE-Measured values

**i** Two menus, "DATA MEMORY 1" and "DATA MEMORY 2", are only **for the two-channel version**. In the one-channel version there is only one menu "DATA MEMORY".

Selection	Display	Info
Measured values		The data memory contains the last 1024 concentration measured values with date and time. If there are no values available, "Empty set" appears. Browse through the data sets by pressing the  and  keys.
Serial output		You can output <b>all</b> data sets (in ASCII-format) via the serial interface. For this, the receiving end (PC) must be configured like this: 9600, N, 8, 1. To send data, the receiving end (PC) must send the ASCII character 81 ("Shift", "D").
Clear data		This deletes <b>all</b> data sets.

### 5.2.9 DATA STORAGE-Calibration data

**i** To enter this menu select the CONFIGURATION menu, browse to the "Calibration factor" option and press the key.

Selection	Display	Info
Calibration factor		This data memory contains the last 100 calibration factors with date and time. If there are no values available, "Empty set" appears. Browse through the data sets by pressing the  and  keys.
Serial output <b>only available via PC!</b>	no display	You can output <b>all</b> data sets (in ASCII-format) via the serial interface. For this, the receiving end (PC) must be configured like this: 9600, N, 8, 1. To send data, the receiving end (PC) must send the ASCII character 81 ("Shift", "C").
Clear data		This deletes <b>all</b> data sets.

## 5.3 Modbus RS485

The Modbus module is pre-configured at the factory (see "Protocol specific data", → 57). The measured value is transmitted as current value [mA], that is calculated from an internal register value.



## 5.4 Calibration

### 5.4.1 Standard calibration data

The signal strength is processed device-internally as a frequency.

The following table provides an overview of the standard calibration data.

-  Compare these values to your own data.  
After changes in the CONFIGURATION menu and in case of software updates, you can check and, if necessary, change the calibration data in the sub-menu.

	Measuring range	Concentration [mg/l]	Frequency [Hz]
Ammonium, lower measuring range AM-A	0.1 to 5.0 mg/l	0.0	0
		0.5	251
		1.0	515
		1.5	831
		2.0	1059
		2.5	1319
		3.0	1525
		3.5	1741
		4.0	1902
Ammonium, medium measuring range AM-B	0.2 to 15.0 mg/l	0.0	0
		1.5	325
		3.0	679
		4.5	972
		6.0	1320
		7.5	1603
		9.0	1840
		10.5	2054
		12.0	2342
Ammonium, upper measuring range AM-C	0.2 to 100.0 mg/l	0.0	0
		10.0	721
		20.0	1419
		30.0	2038
		40.0	2637
		50.0	3037
		60.0	3338
		70.0	3441
		80.0	3550
100.0	3834		
Ammonium, lowest measuring range AM-D	1 to 500 µg/l	0	0
		50	357
		100	728
		150	1075
		200	1423
		250	1693
		300	1992
		350	2233
		400	2400
500	2710		

### 5.4.2 Calibration example

- i** Complete calibration, consisting of two offset measurements and one standard measurement, is triggered via the automatic calibration mode.  
In addition, you can start offset and standard calibration manually via the CONFIGURATION menu and view the current calibration data.

You want to activate an immediate calibration (e.g. after you have replaced the reagents). Ensure that you have changed the reagents, filled the hoses again (no air bubbles) and the analyzer is in measuring mode.

1. Hold **M** down until AUTO MEASURING appears.
2. Use **↓** to move through the PARAMETER ENTRY menu and press **E**.
3. Use **E** to go to the "1st calibration" option.
4. Now use the **↓** or **↑** and **E** keys to set a time which lies in the past.
5. Press **E** to accept the value and then press **M** twice to return to the main menu (AUTO MEASURING).
6. Press **E** again. This takes you back to measuring mode.  
The calibration is now carried out automatically.

#### **NOTICE**

**After the calibration has finished, the analyzer automatically switches to the measuring mode.**

- ▶ You now have to set the time of the 1st calibration back into the future in order to align the calibration and rinsing times to each other. The rinse must be performed 3-4 hours before the next calibration.
- ▶ Proceed as described above to change the setting for the time of the 1st calibration. After changing to measuring mode, the analyzer automatically begins measuring, rinsing and calibrating at the defined times.

## 6 Commissioning

### 6.1 Function check

#### **⚠ CAUTION**

**Avoid damage due to incorrect power supply and inaccurate or insecure hose connections**

- ▶ Check that all connections are secure. In particular, ensure that all hose connections are secure, so that no leaks occur.
- ▶ Ensure that the power supply voltage corresponds to the voltage specified on the nameplate.

### 6.2 Switch-on

#### 6.2.1 Dry commissioning

When the analyzer has been configured and calibrated, the measuring cycle starts automatically. Configuration is no longer necessary.

To perform initial commissioning or to readjust the device parameters, proceed as follows:

1. Plug in the analyzer's plug with grounding contact into the socket.
2. Press the **[M]** key until AUTO MEASURING is displayed.
  - If possible, let the analyzer warm up in standby mode before commissioning ("Auto measuring" display). The time can be defined via the "1. measurement" option in the PARAMETER ENTRY menu.
  - At the start of measurement with a cold analyzer, the first measuring results will be incorrect. The reaction is temperature-dependent and if the temperature is too low the predefined reaction time is insufficient for a complete reaction. For this reason, never carry out calibration with a cold analyzer. Wait at least two hours before carrying out calibration.
3. Select the CONFIGURATION menu and configure up to and including "Current date/time". With **[M]** you can return to the main menu.
4. Now work through the PARAMETER ENTRY and SERVICE menus. With **[M]** you can return to the main menu.
5. Select CONFIGURATION again and use **[E]** to go to the "Calibrate offset" menu item.
6. Connect a vessel containing distilled water to the "Sample" connection and start the frequency offset (**[K]** key). The value determined is displayed and saved.
7. Then reconnect the sample line. With **[M]** you can return to the main menu.

The analyzer starts automatically (triggered by a control signal or integrated timer) with the "Calibration", "Measurement" and "Flushing" procedures in accordance with the device parameters that you have set (1st calibration, 1st measurement, 1st flushing times and the respective intervals control the procedure).

**Settings for CA71AM-A/B/C**

	Function	Duration [s]	Range of adjustment
Measurement	Flushing (sample)	3 x 15	CONFIGURATION / "Delay to sample"
	Delay to sample	20 to 999	
	Stabilization	8	SERVICE / "Pumps and valves"
	1. measurement (basis)		
	Fill mixture	30	
	Reaction	see Technical data	
	2nd measurement (plateau)		
Flushing (sample)	30		
Calibration	Flushing (standard)	3 x 15	CONFIGURATION / "Delay to sample"
	Delay to standard	20 to 999	
	Stabilization	8	SERVICE / "Pumps and valves"
	1. measurement (basis)		
	Fill mixture	30	
	Reaction	see Technical data	
	2nd measurement (plateau)		
Flushing (sample)	20		
Flushing	Pump cleaning solution	½ Flush hold on	PARAMETER ENTRY / "Flushing hold on"
	Allow to react	5	
	Pump cleaning solution	½ Flush hold on	

**Settings for CA71AM-D**

	Function	Duration [s]	Range of adjustment
Measurement	Flushing (sample)	3 x 15	CONFIGURATION / "Delay to sample"
	Delay to sample	20 to 999	
	Stabilization	8	SERVICE / "Pumps and valves"
	1. measurement (basis)		
	Flushing (reag. line)	2	
	Fill mixture	15 to 18	
	Reaction	see Technical data	
	2nd measurement (plateau)		
	Empty cell		
Flushing (sample)	30		
Calibration	Flushing (standard)	3 x 15	CONFIGURATION / "Delay to sample"
	Delay to standard	20 to 999	
	Stabilization	8	SERVICE / "Pumps and valves"
	1. measurement (basis)		
	Flushing (reag. line)	2	
	Fill mixture	15 to 18	
	Reaction	see Technical data	
	2nd measurement (plateau)		
	Empty cell		
Flushing (sample)	30		
Flushing	Pump cleaning solution	½ Flush hold on	PARAMETER ENTRY / "Flush hold on"
	Allow to react	5	
	Pump cleaning solution	½ Flush hold on	

### 6.2.2 Wet commissioning

Wet commissioning is different to dry commissioning in that in wet commissioning you fill the reagent lines before the automatic cycles are started.

Proceed as follows:

1. Plug in the analyzer's plug with grounding contact into the socket.
2. Press the **M** key until AUTO MEASURING is displayed.
3. Select the SERVICE menu.
4. Switch the P2 reagent pump "on" (select P2 with **E** and set to "g" with **↑**) and leave it running until you can tell that there are reagents at the T-hose connector. After this, switch P2 "off" (s) again with **↓**.
5. Now switch the valves to passage for standard (select V1: S, V2: S; with **E** or **CE** switch to "S" with **↑**) and then switch the P1 sample pump "on". Leave the pump running until you can tell that there is standard at the T-hose connector. Switch P1 back "off".
6. Now switch the valves to passage for cleaning agent (select V1: S, V2: R; with **E** or **CE**, switch to "R" with **↑**) and then switch the P1 sample pump "on". Leave the pump running until you can tell that there is cleaning agent at the T-hose connector. Switch P1 back "off".
7. Now switch the valves to passage for sample (select V1: P, V2: S; with **E** or **CE**, switch to "P" and "S" with **↑**) and then switch the P1 sample pump "on". If you notice that sample is present at the T-hose connector, let the pump run for another 2 minutes. This removes any standard or cleaner residues.  
Then switch P1 "off".
8. Now proceed as with dry commissioning (from step 2).

### 6.2.3 Using a dilution module

You can extend the measuring range of your analyzer with the sample dilution module.

How it works:

- The analyzer determines the absorption of the sample at the specified wavelength.  
It does not matter whether the sample was diluted previously or not.
  - The characteristic of the photometer (→ standard calibration data) refers to the concentrations of the diluted sample and not to those of the (undiluted) original sample.
  - The dilution factor is not taken into account until the measured value is calculated.
  - The concentration information you specify for the measuring range and the alarm values in PARAMETER ENTRY refer to the concentrations of the original sample.
- i** You achieve maximum measuring accuracy if you also dilute the standard with the dilution module.  
In the event of a 1:10 dilution, you have to use a 10 mg/l standard solution instead of a 1.0 mg/l standard solution (without a dilution module) for example.  
Balance changes to the dilution ratio (e.g. through hose aging) with the calibration. The calibration factor determined takes into account all deviations from the ideal state through reagents, the photometer and dilution.

### Installing the dilution module

The dilution module is supplied ready to use.

Installation:

1. Release the sample pump hose from the hose connector to valve 1 (→  21, item 4).
2. Connect the sample hose of the dilution module (black/black or yellow/blue, depending on the version) to the hose connector that is now free.
3. Connect the T-section (item 1) of the dilution module to the input of the sample pump (hose box K1). Use the original sample pump hose for this purpose.
4. Fit the dilution module onto the free hose box positions of the sample pump.
5. Connect an outflow hose (O) to the free outlet of the T-piece (item 1). Route this hose in the device in such a way that is guided at least 20 cm upwards and then into the open outlet. This prevents the hose from running dry.

### NOTICE

#### Measuring errors due to malfunctioning outflow from photometer

Backwater, siphon effects or similar influence the sample outflow and cause measuring errors

- Do not connect the outflow hoses of the dilution module and the photometer.

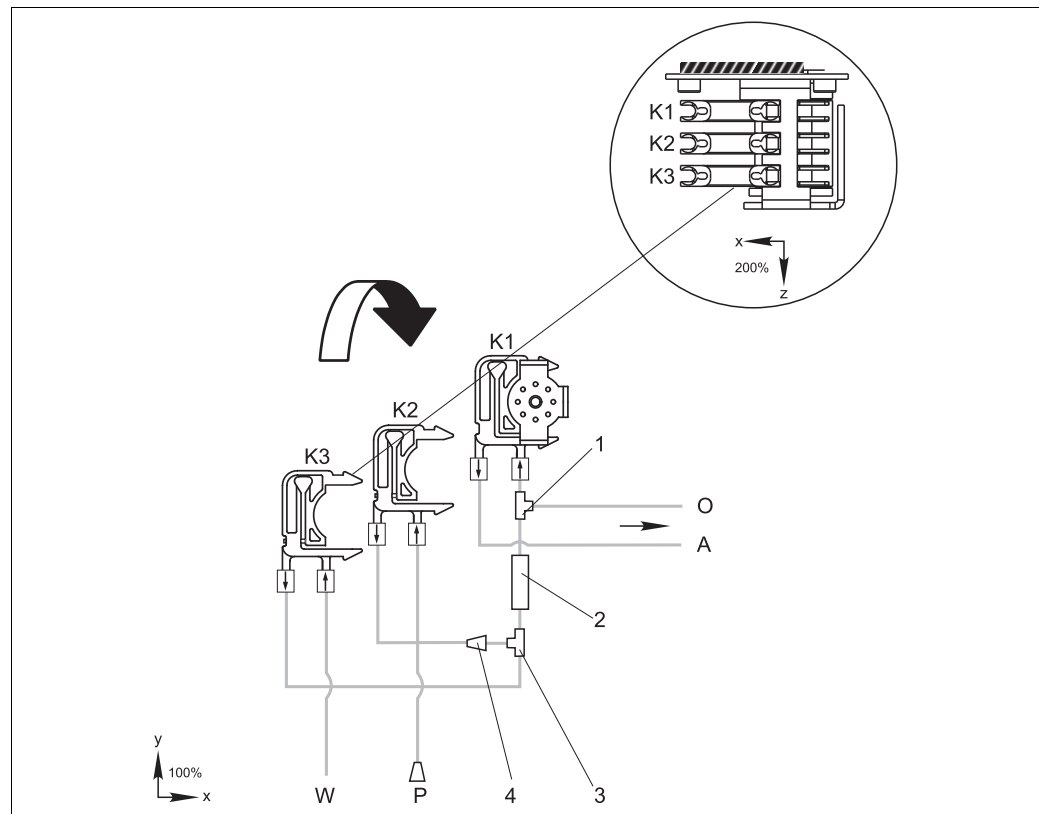



Fig. 21: Dilution module

- K1 Hose box of the original sample pump
- K2 Hose box for additional sample (standard)
- K3 Hose box for dilution water
- A Sample supply to photometer
- O Overflow (in outlet of analyzer)
- P Sample hose (sample or standard)
- W Dilution water inlet (to be provided by the client)
- 1 T-section 3.2 x 3.2 x 3.2 mm (0.13 x 0.13 x 0.13 inch)
- 2 Static mixer 122-012
- 3 T-section 3.2 x 3.2 x 3.2 mm (0.13 x 0.13 x 0.13 inch)
- 4 Hose connector 3.2 x 1.6 mm (0.13 x 0.06 inch)

### Changing parameters

 The following section only lists the parameters where you have to make changes to the standard settings.

Start with CONFIGURATION.

CONFIGURATION	
Delay to sample	Increase the value of the standard setting by 40 seconds since additional sample volume is drawn in.

PARAMETER ENTRY	
Measuring range start 1 / measuring range start 2	Enter values that refer to the concentration of the undiluted sample. If you are using a dilution module with the factor 10, for example, multiply the settings to date (without the dilution module) by 10.
Measuring range end 1 / measuring range end 2	
Alarm values AV 1-1 / 1-2 / 2-1 / 2-2	
Calibration solution	Enter the original concentration (undiluted) of the standard here.

## 7 Maintenance

### ⚠ CAUTION

**You must not carry out any procedures not listed in the following chapters, yourself.**

► Not listed works must only be carried out by the service.

**i** If you use components for maintenance or modification, which are not approved by Endress+Hauser, the warranty and the certified conformity of the device will become void.

### 7.1 Maintenance schedule

All maintenance duties that have to be carried out during normal operation of the analyzer are explained below.

If you are using a sample conditioning unit, e.g. CAT430, coordinate the maintenance work required for it with that of the analyzer. For this, read the maintenance chapter in the respective operating instructions.

Period of time	Duty	Note
Weekly	<ul style="list-style-type: none"> <li>– Check and note calibration factor (for service purposes)</li> <li>– Move valve hoses into their position and spray with silicone (extends the service life).</li> </ul>	CONFIGURATION
Monthly	<ul style="list-style-type: none"> <li>– Flush sample line hose system with pressurized water (disposable syringe), check and replace reagents if necessary</li> <li>– Grease pump hoses with silicone grease</li> <li>– Check sample collector for fouling and clean it if necessary</li> </ul>	<ul style="list-style-type: none"> <li>– Remove the cassette of the sample pump.</li> <li>– Connect the one-way syringe instead of the sample inlet.</li> </ul>
Every 3 months	<ul style="list-style-type: none"> <li>– Cleaning the drain lines: Flush all hoses and then rinse with sample for at least 30 minutes</li> <li>– Rotate pump hoses</li> <li>– Cleaning of the filter mat of the housing fan</li> </ul>	<ul style="list-style-type: none"> <li>– SERVICE: V1: P, P1: g, P2: s, V2: S, V3: P Add solution to sampling connection</li> <li>– s. chapter "Replacing the pump hoses"</li> <li>– s. chapter "Cleaning the filter mat of the housing fan"</li> </ul>
Every 6 months	<ul style="list-style-type: none"> <li>– Replace pump hoses</li> <li>– Replace valve hoses</li> </ul>	<ul style="list-style-type: none"> <li>– see chapter "Replacing pump hoses"</li> <li>– see chapter "Replacing valve hoses"</li> </ul>

**i** Whenever working on the reagent hoses, the hoses must be disconnected from the canisters, in order to prevent contamination of the reagents. Empty the reagent hoses via the service menu.



## 7.2 Replacing reagents

### **▲ CAUTION**

#### **Corrosive chemicals and other risks**

Eye or skin injuries or crushes possible

- ▶ There is a danger of crushing limbs at doors, inserts and pump heads.
- ▶ Refer to the warning instructions in the safety data sheets when handling reagents or cleaning solutions. Wear protective clothing, gloves and goggles.
- ▶ Make sure the workplace is well ventilated when you work with bleaching lye. If you feel unwell, consult a physician immediately.
- ▶ If reagents come into contact with the skin or eyes, carefully rinse with copious amounts of water and consult a physician immediately.
- ▶ Never add water to reagents. Reagents containing acids may splash and heat may build up.

If you store the reagents correctly (in the dark, not over 20 °C) they will be stable for minimum 12 weeks from the date of manufacture (batch number). When this period of time has expired, the reagents must be replaced. Shelf life can be prolonged by keeping the reagents in a dark, cool storage place. The reagents absolutely must be replaced when:

- The reagents have been contaminated by sample (see "Trouble-shooting instructions")
- The reagents are too old
- The reagents have been spoiled by incorrect storage conditions or environmental influences.

### 7.2.1 Checking reagents

1. Check the concentration of the standard in the laboratory. Adapt the values (PARAMETER ENTRY, calibration solution") or replace the standard solution.
2. Mix 5 ml of standard ( $c=500 \mu\text{g}/\text{l}$  or higher) and 5 ml each of reagent AM 1 and AM 2 in a beaker.

The finished mixture must be free of particles.

The reagents must be replaced if no visual coloration (green-blue) occurs after max. 2 minutes (AM-A/B/C) or 10 minutes (AM-D), or if the mixture is not free of particles.

### 7.2.2 Replacing reagents

1. Carefully remove the hoses from the canisters and wipe them with a clean and dry (paper) towel. Wear protective gloves when doing this.
2. Switch on the reagent pump for about 5 seconds for the hoses to be drained.
3. Flush the reagent hose externally with plenty of distilled water.  
For this purpose, place a beaker with distilled water into the device.
4. Wipe the reagent hose with a clean and dry (paper) towel.
5. Replace the reagent canisters and feed the hoses into the new canisters.
6. Fill the reagent hose with the new reagents (SERVICE). Switch all pumps to "g" for this purpose. Do not switch the pumps off ("s") until no more air bubbles are to be seen in the hoses.
7. Determine the reagent blank value by using deionized water as a sample (see "CONFIGURATION").  
The value determined is saved by the analyzer as the frequency offset.
8. Carry out a calibration (see chapter "Calibration").

## 7.3 Replacing pump hoses

### ⚠ CAUTION

#### Risk of splashing reagents when removing hoses from the hose nozzles

- ▶ Wear protective clothing, gloves and goggles.

The peristaltic pumps used for the analyzer convey the medium in a combination of vacuum and displacement pump. The pump rate is dependent on the elasticity of the pump hoses. Elasticity decreases and the pump rate drops as mechanical stress increases. Wear depends on mechanical stress (measuring interval, pump pressure). The wear effect can be compensated by periodical calibration. If the hose elasticity becomes too low and the pump rate is no longer reproducible, it is necessary to replace the hoses.

#### Removing the old hoses

1. Remove the reagent hoses from the reagent canisters in order to prevent contamination of the reagents.
2. Flush the old hoses with water first and then with air to empty them (see SERVICE).
3. Remove the hoses from the nipples of the hose boxes (item 5).
4. Release the hose box(es) (1 to 3 per pump):
  - Press against the lower retainer (item 3).
  - You can now remove the hose box along with the pump hose.
  - Remove the old hose from the box any dispose of it.
  - Clean the hose box and the roller head (item 1) with a tissue.

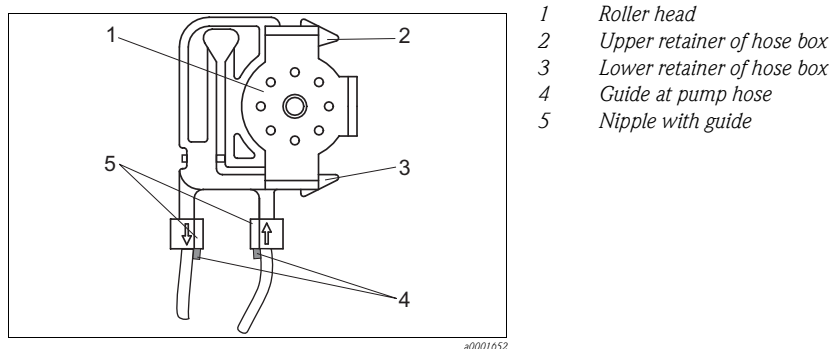

Fig. 22: Reagent pump

### Installing the new hoses

1. Grease the new pump hoses and the pump heads with silicone grease.

#### NOTICE

#### Danger of mix-up and resulting malfunction

- ▶ Make sure you connect the new pump hoses to the correct connections at the T-hose connector.
- ▶ For the order numbers of the pump hoses, see the chapter "Troubleshooting"/"Spare parts".

2. Fit the new hose on the hose box.
  3. First pull the hose downwards at both ends and then push the guide on the hose into that of the nipple on the hose box. Make sure it is seated correctly.
  4. First place the hose box into the upper retainer (item 2) of the pump and then press the box into the lower retainer (item 3).
- Make sure the hose boxes are in the correct order in the pump (→  23).

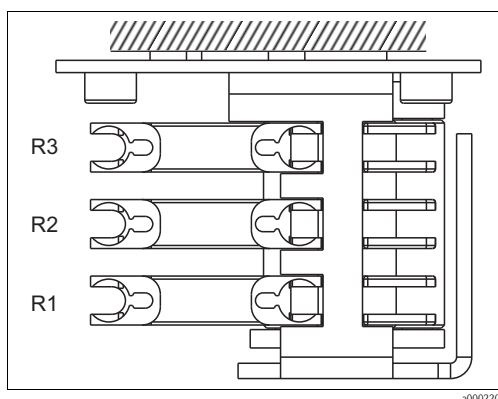

Fig. 23: Reagent pump, top view

R1 Reagent 1  
 R2 Reagent 2 (if present)  
 R3 Reagent 3 (if present)

5. Reconnect the reagent hoses to the canisters.
6. After installation, refill the hoses with sample, standard or cleaner (SERVICE)<sup>1)</sup>.
7. Carry out an offset calibration and a calibration.

1) Make sure that the hoses are bubble-free when filled. If not, check the sample flow rate (see below).

### Setting the contact pressure of the pump

If the pump hoses cannot be filled free of bubbles, adjust the adjuster screw for the contact pressure of the pump:

1. Release the adjuster screw (→  24, item 3) to the extent that no more sample is pumped.
2. Tighten the screw just to the point that sample is pumped.
3. Tighten the screw another complete rotation.

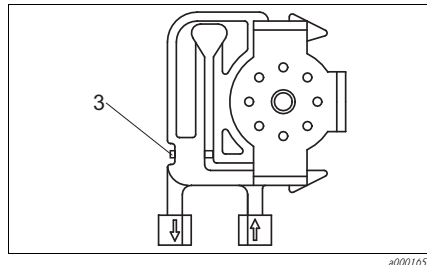

Fig. 24: Sample pump

3 Adjuster screw for the contact pressure

#### NOTICE

**The reagent would become immediately unusable if sample is pumped into it.**

- ▶ Adjust the contact pressure of the reagent hoses so that no sample is pumped into the reagent.
- ▶ Only perform tests with distilled water.

## 7.4 Replacing valve hoses

To replace the hoses, proceed as follows:

1. Rinse the old hoses first with water and then with air to empty them (see SERVICE).
2. Remove the hoses from the valves:
  - a. You can disconnect the front hoses directly because the valves are open when de-energised.
  - b. To remove the back hoses, press the black button on the valve and disconnect the hoses.
3. Grease the new hoses with silicone grease before inserting them.
4. Install the new valve hoses in the reverse sequence of operations. Ensure that the hoses are connected correctly (→  25).
5. After installation, refill the hoses with sample, standard or cleaning agent (SERVICE).
6. Carry out an offset calibration and a calibration.

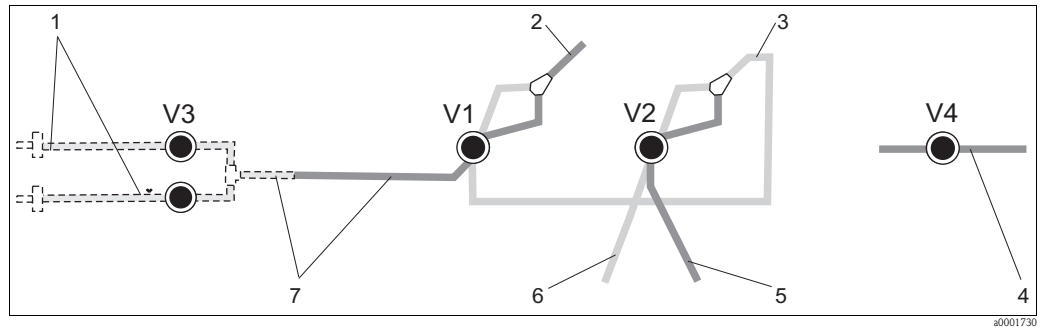

Fig. 25: Valves and valve hoses

- V1-4 Valves 1, 2 and 4 (if present)  
 V3 Valve 3, two channel switch (optional)  
 1 Sample  
 2 To the pump  
 3 Y-piece, connecting hose to valve 1, behind it  
 4 Outlet hose  
 5 Hose valve 2, front, standard  
 6 Hose valve 2 back, cleaning agent  
 7 Hose valve 1 front, sample

## 7.5 Replacing the static mixer

To replace the mixer, proceed as follows:

1. Rinse first with water and then with air (see SERVICE).
2. Unscrew the four screws on the photometer housing and remove it.
3. Disconnect the mixer from the photometer and from the T-piece below the photometer housing or release the mixer from the holder.
4. Remove the old mixer and insert the new one.
5. Connect the new mixer to the photometer and the T-piece again.
6. Attach the photometer housing and screw it down.
7. After installation, refill the hoses with sample, standard or cleaning agent (SERVICE).
8. Carry out an offset calibration and a calibration.

## 7.6 Replacing the photometer optical cell

### NOTICE

**Electrostatic discharge (ESD) can cause damage to electronic assemblies**

- Discharge yourself at a protective earth before handling the assemblies.

### Removing the old cell

1. Rinse first with water and then with air (see SERVICE).
2. Switch the analyzer off.
3. Unscrew the four screws on the photometer housing and remove it.
4. Release the nuts from the guide screws and remove the photometer completely.
5. Unscrew the four screws on the side of the photometer on which there is no ribbon cable.
6. Take the photometer's electronics apart.
7. Take out the cell and remove the hoses.

**NOTICE**

**Traces of grease on the optical surfaces can cause corrupted measured values**

- ▶ Do **not under any circumstances** touch the optical window of the cell with your fingers.

**Installing the new cell**

1. Insert the new cell.
2. Connect the cell to the hoses such that the sample is fed in from below.
3. Secure the hoses with the supplied cable connectors to stop the cell from slipping.
4. Reassemble the photometer and tighten the screws and nuts.
5. Attach the photometer housing and screw it down.
6. After installation, refill the hoses with sample, standard or cleaning agent (SERVICE).
7. Carry out an f-offset measurement (CONFIGURATION) and a calibration ("Calibration").

## 7.7 Cleaning

**NOTICE**

**When cleaning, ensure that you do not damage the nameplate on the analyzer.**

- ▶ Do not use any solvent-based cleaning agents.

To clean the analyzer housing, proceed as follows:

- Stainless steel housing (stainless steel SS 1.4301 (AISI 304)): with a lint-free cloth and Glittol RG 10.51
- GFR housing: with a damp cloth or with tenside-based (alkaline) cleaning agent.

## 7.8 Placing out of service

You must place the analyzer out of service before shipping or before longer operation breaks (more than 5 days).

**⚠ CAUTION**

**Residues of chemicals can cause injuries**

- ▶ Thoroughly rinse all of the lines of the measuring system with ultrapure water.

To place the analyzer out of service, proceed as follows:

1. Remove the reagent and standard hoses from the canisters and immerse them in a tank containing ultrapure water.
2. Switch valve 1 to "Standard" and switch pumps 1 and 2 on for one minute (see SERVICE).
3. Remove the hoses from the water and allow the pumps to run until the hoses are completely dry.
4. If you are using a continuous sample supply, disconnect sampling line.
5. Flush sampling hoses with ultrapure water and then with air, in order to completely empty the hoses.
6. Remove the valve hoses from the valves.
7. Remove the load from the pump hoses by removing the hose cassette from the bracket below.

- i** Keep opened reagents and standards in a refrigerator. Observe the shelf-life.

## 8 Accessories

**i** In the following sections, you find the accessories available at the time of issue of this documentation.

For information on accessories that are not listed here, please contact your local service or sales representation.

### 8.1 Collecting vessel

- for sampling from pressurized systems
- results in an unpressurised continuous sample stream
- Collecting vessel without level measurement; order no. 51512088
- Collecting vessel with level monitoring (conductive); Order no. 51512089
- Level monitoring retrofit kit; Order no. 71023419

### 8.2 Reagents, cleaner, standard solutions

- Reagent set active, 1 l reagent AM1+AM2 each; order no. CAY140-V10AAE
- Reagent set inactive, for 1 reagent AM1+AM2 each; order no. CAY140-V10AAH
- Cleaning agent, 1l; order no. CAY141-V10AAE
- Standard solution 100 µg/l NH<sub>4</sub>-N; order no.CAY142-V10C01AAE
- Standard solution 500 µg/l NH<sub>4</sub>-N; order no.CAY142-V10C02AAE
- Standard solution 5 mg/l NH<sub>4</sub>-N; order no.CAY142-V10C05AAE
- Standard solution 10 mg/l NH<sub>4</sub>-N; order no.CAY142-V10C10AAE
- Standard solution 15 mg/l NH<sub>4</sub>-N; order no.CAY142-V10C15AAE
- Standard solution 20 mg/l NH<sub>4</sub>-N; order no.CAY142-V10C20AAE
- Standard solution 30 mg/l NH<sub>4</sub>-N; order no.CAY142-V10C30AAE
- Standard solution 50 mg/l NH<sub>4</sub>-N; order no.CAY142-V10C50AAE
- Standard solution 100 mg/l NH<sub>4</sub>-N; order no.CAY142-V10C88AAE

#### NOTICE

#### Reagents can cause environmental damage

- Note the disposal instructions in the safety data sheets of the reagents.

### 8.3 Maintenance kit

CAV740, maintenance kit for CA71

- Pump hoses
- Valve hoses
- Hose connectors
- Ordering acc. to product structure

For CA71 parameter	
2	AM-A/B/C
5	HA, AL, AM-D, FE-D, NO-D
Inlet and outlet hoses	
A	not selected
B	selected, for CA71AM-A/B/C
C	selected, for CA71AM-D
CAV740-	complete order code

## 8.4 Hose cleaner

- Cleaning agent, alkaline, 250 ml (8.5 fl.oz.); order no. CAY746-V02AAE
- Cleaning agent, acidic, 250 ml (8.5 fl.oz.); order no. CAY747-V02AAE

## 8.5 Dilution module

Dilution module

1 set of pump hoses, 2 hose boxes, 1 set of hose connectors, static mixer

- Dilution 1:3  
Order no. C-A030228-10
- Dilution 1:10  
Order no. C-A030228-11

## 8.6 Additional accessories

- Interference suppressor for control, power and signal lines  
order no. 51512800
- Silicon grease, tube, 35 g  
order no. 71017654
- Valve set, 2 pieces, for two-channel version  
order no. 51512234
- Upgrade kit for upgrading from one-channel to two-channel version  
order no. 51512640



## 9 Trouble-shooting

### 9.1 Trouble-shooting instructions

Although the analyser is not very prone to faults due to its simple assembly, problems can, of course, not be completely ruled out.

Possible errors, their causes and their possible remedies are listed below.

### 9.2 System error messages

Error message	Possible cause	Tests and / or corrective measures
Calibration failed		If a calibration fails, you can enter a new calibration factor manually (CONFIGURATION menu, "Calibration factor"). Cancel the error message by switching the analyzer off and on briefly. If the error occurs frequently, you will have to search for the cause.
	Air bubbles in system	Start calibration manually (PARAMETER ENTRY, "1. calibration", change the date accordingly, start measurement) or enter a new calibration factor.
	Incorrect concentration of standard	Check the concentration in the laboratory. Adjust the standard accordingly ("PARAMETER ENTRY", "Calibration solution") or replace the standard.
	Reagents contaminated or aged	Simple check: Mix 5-10 ml of standard solution (of a high concentration) and 5 ml of reagent in a beaker. If it does not change color after max. 10 min, replace the reagents.
	Standard dosing defective	Check the valves for contamination, obstructions (visual inspection). Replace valve hoses if necessary.
	Incorrect photometer	Check the setting in the CONFIGURATION menu.
Cell dirty	Not enough light intensity at receiver	<ul style="list-style-type: none"> <li>- Flush with 12.5% bleaching lye.</li> <li>- When using a CAT430: Check the filter.</li> </ul>
Incorrect photometer	Incorrect photometer	Check the setting in the CONFIGURATION menu, "Photometer".
No sample	No sample	Establish sample transfer.
	Level measurement defective	Check level measurement at the sample collector.
Spillage error	Leak at canisters or hoses	Replace defective components and clean and dry the analyzer or those components affected by the leak.
No measuring signal	Cell filled with air	Pump sample for 1 minute (SERVICE).
	Photometer defective	Inform Service
	Electrical connection	Check all electrical connections and make sure the fuses are firmly seated.
	Fuse defective	Replace fuse F4 or F5 (semi-delay 0.2 A)

### 9.3 Process errors without messages

Error	Possible cause	Tests and / or corrective measures
Measured values always the same	Reagents contaminated or aged	Simple check: Mix 5-10 ml of standard solution (of a high concentration) and 5 ml of reagent in a beaker. If it does not change color after max. 10 min, replace the reagents.
	No sample, no reagents	Make sure sample and reagents are supplied, check level monitor and clean if necessary
	System blocked	Flush with 12.5% bleaching lye. Check the hose from valve 4.
Measured values inaccurate	Incorrect concentration of standard	Check the concentration in the laboratory. Adjust the standard accordingly ("PARAMETER ENTRY", "Calibration solution") or replace the standard.
	Reagents contaminated or aged	Simple check: Mix 5-10 ml of standard solution (of a high concentration) and 5 ml of reagent in a beaker. If it does not change color after max. 10 min, replace the reagents.
	Reagent blank value too high	After replacing the reagents, carry out an offset calibration and then a calibration (CONFIGURATION, "Offset calibration")
	Wrong dimension	Check the setting in the CONFIGURATION menu, "Measuring unit" (e.g. ion instead of element).
	Wrong cell	Check the setting in the CONFIGURATION menu, "Photometer"
	Sample suction time too short	Increase the suction time (CONFIGURATION, "Delay to sample")
	Matrix effects (substances that interfere with the photometric method)	Detect interfering substances (see Technical Information, "Measuring principle"), possibly use sample conditioning
	Filter life too long	Take a counter sample at the analyzer inlet and check the concentration in the laboratory. If there is no deviation to the analyzer measured values, replace the ultrafiltration modules or reversible flow filters more frequently.
	System blocked or contaminated	Flush with 12.5% bleaching lye.
	Dosing	Replace pump hoses.
Cell dirty	Flush with 12.5% bleaching lye first and then with 5% hydrochloric acid	
Measured values inaccurate	Standard is dosed to the sample	Check the valves and valve settings. Replace valve hoses if necessary.
Counter sample in the laboratory delivers deviating measured values	Sample aging	Shorten time between sampling and analysis.
Measured value transfer defective	Wrong size for analog output	Check the setting (CONFIGURATION, "Analog output 1" or " 2").
	Incorrect measuring range	Adjust measuring range (PARAMETER ENTRY, "Measuring range")
	Background noise	Check electrical cables for interference from strong sources of induction.
Analyzer will not switch on	No power	Check the electrical connection and ensure power supply.
	Fuse	Replace fuse F1 (slow-blow 0.5 A)
Analyzer is running but display is incomplete or off	Initialization failed	Switch the analyzer off and after approx. 30 seconds back on.
Pumps fail to run	Leak	See "Spillage error" error message
	Leak sensor bypassed	Interrupt the contact between the two leak sensors (terminals 67-66)
	Fuse	Check all fuses and replace if necessary.
	Pump defective	Service
Measurement does not start	Leak at photometer	Service

Error	Possible cause	Tests and / or corrective measures
"Measurement" display flashes	Time of 1st measurement not reached	The date must be between 01.01.1996 and the current date.
	Interval not expired	Change parameter setting.
Calibration does not start	Time of 1st calibration not reached	The date must be between 01.01.1996 and the current date.
	Interval not expired or 0 h	Change parameter setting.
	Leak at photometer	Service
Flushing does not start	Time of 1st flushing not reached	The date must be between 01.01.1996 and the current date.
	Interval not expired or 0 h	Change parameter setting.
Leak at photometer	Device or discharge blocked	Remove blockage. Service
Blockage, deposits in device	Not enough sample conditioning	Shorten the cleaning intervals of sample conditioning.
	Water hardness	Lime deposits can be removed by flushing with 5% hydrochloric acid. If necessary, dose EDTA in sample stream to prevent precipitation.

## 9.4 Spare parts

### 9.4.1 Overview for CA71AM-A/B/C

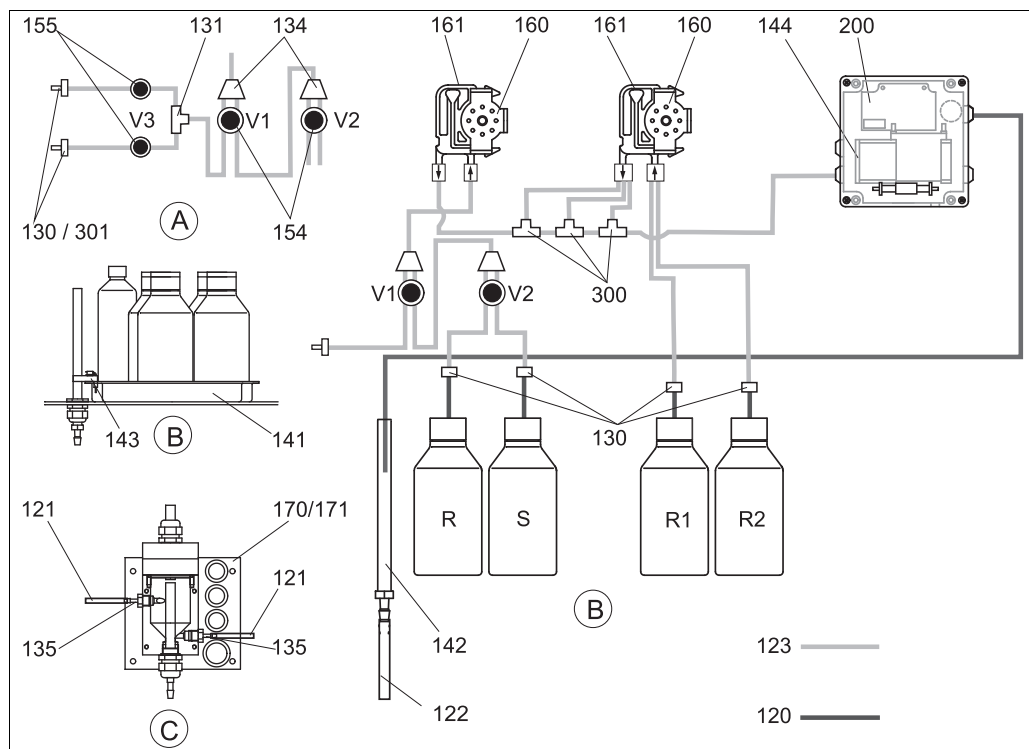

Fig. 26: Overview parts

- A Sample input two-channel version
- B Standards and reagent canisters
- C Collecting vessel
- P Sample

- R Cleaner canister
- R1 Reagent 1 canister
- R2 Reagent 2 canister
- S Standard solution canister

### 9.4.2 Overview for CA71AM-D

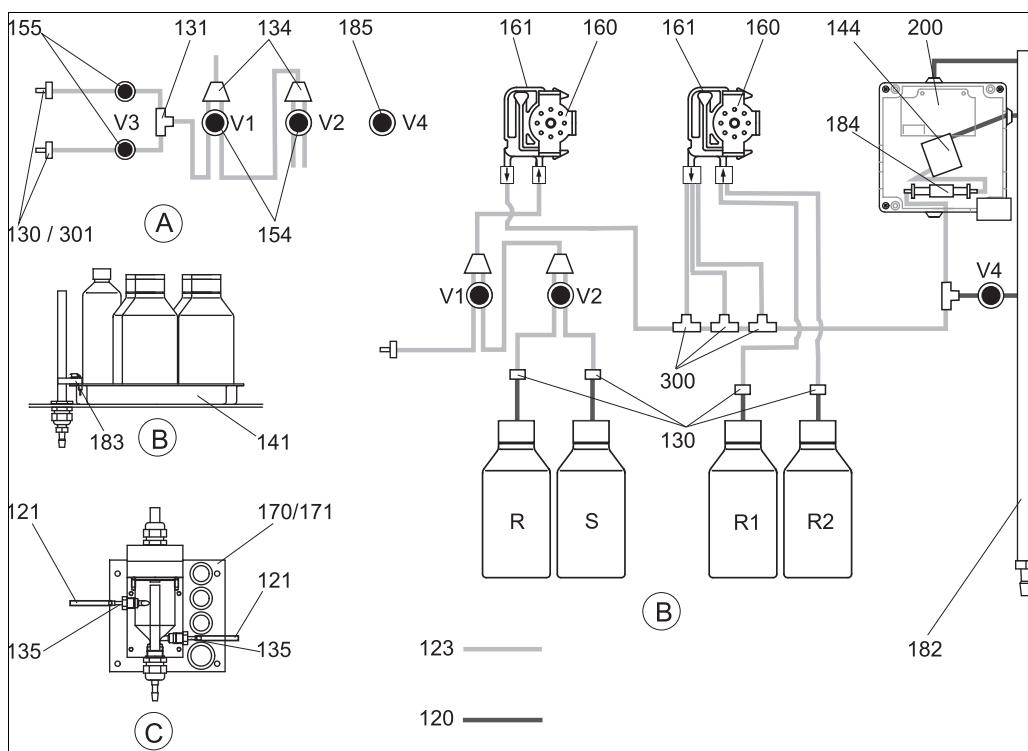

Fig. 27: Overview of spare parts

- |   |                                  |    |                            |
|---|----------------------------------|----|----------------------------|
| A | Sample input two-channel version | R  | Cleaner canister           |
| B | Standards and reagent canisters  | R1 | Reagent 1 canister         |
| C | Collecting vessel                | R2 | Reagent 2 canister         |
| P | Sample                           | S  | Standard solution canister |

### 9.4.3 Spare parts for sample and reagent transportation

Item	Spare part	Order number
120	Norprene hose, 1.6 mm	51504116
121	C-Flex hose, 3.2 mm (permeate inlet and overflow with sample collector.)	51504114
122	C-Flex hose ID 6.4 mm	51504115
123	C-Flex hose, 1.5 mm	51512535
130	Hose connector 1.6 mm x 1.6 mm (10 pieces)	51506495
131	T-hose connector 1.6 mm x 1.6 mm x 1.6 mm (10 pieces)	51506490
134	Y-hose connector 1.6 mm x 1.6 mm x 1.6 mm (10 pieces)	51512096
135	Connection nipples for sample collector (10 piece)	51512099
136	T-hose connector 3.2 mm x 3.2 mm x 3.2 mm (10 pieces)	51516166
140	Mixer set, complete (2 pieces)	51512101
141	Collecting tank	51512102
142	Outlet pipe with hose nipple (2 pieces)	51512104
143	Kit CA71 Leak sensor for collecting tank (2 pieces)	51512103
154	Kit CA71 Valve, complete (1 piece for one-channel version)	51512100
155	Valve set for two-channel version	51512234
160	Roller head with holder for hose pump	51512085
161	Kit CA71 Hose box for pump (1 piece)	51512086

Item	Spare part	Order number
170	Collecting vessel with level monitoring	51512089
171	Collecting vessel without level monitoring	51512088
182	Outlet pipe with hose nipple	51515578
183	Leak sensor for collecting tank	51515581
184	Mixer assembly	51515579
185	Drain valve	51515580
300	Kit CA T-hose connectors 1.6 mm x 0.8 mm x 1.6 mm	71039848
301	Kit CA hose connectors 3.2 mm x 1.6 mm	51506491

#### 9.4.4 Analyzer spare parts

Item	Spare part	Order number
130-133	Maintenance kit CAV740 (CA71AM-A/B/C): – 2 sets of pump hoses, yellow/blue (12 piece 51506434) – 1 pack of hose connectors each	CAV740-2A
	Maintenance kit CAV740 (CA71AM-D): – 1 set of pump hoses, yellow/blue (12 piece 51506434) – 1 set of pump hoses black/black (12 piece 51506497) – 1 Grifflex hose, 2 m, ID 19 mm – 1 pack of hose connectors each	CAV740-5C
144	Photometer cell	51505778
200	Photometer – AM-A – AM-B – AM-C – AM-D	51512060
		51512061
		51512062
		51516827

### 9.5 Software history

Date	Version	Changes in the software	Documentation
11/2011	6.3	Improvement <ul style="list-style-type: none"> <li>■ Modification SI-A: additional emptying of the cuvette 45 s before base value</li> <li>■ Modification of the factory default for "Delay to sample"</li> </ul>	BA00353C/07/xx/14.12
11/2011	6.2	Extension <ul style="list-style-type: none"> <li>■ Modbus adapter for one channel versions for the operation at the second current output</li> </ul>	
11/2009	6.1	Improvement <ul style="list-style-type: none"> <li>■ Modified reaction time of AM-C</li> <li>■ Modified revolution speed of the sample pump of AM-B</li> <li>■ Modified filling time of AM-B, HA-B, SI-B</li> </ul>	BA00353C/07/xx/13.11
08/2006	6.0	Extension <ul style="list-style-type: none"> <li>■ New parameter FE-D</li> </ul>	BA360C/07/xx/07.06
06/2006	5.9	Extension <ul style="list-style-type: none"> <li>■ New parameter NO-D</li> <li>■ Stepping motor position is also reset in a reset</li> <li>■ New stepping motor setting for CU-A/B (50 rpm)</li> <li>■ Spanish replaces Dutch and Hungarian</li> </ul>	BA355C/07/xx/07.06

Date	Version	Changes in the software	Documentation
09/2005	5.8	Extension <ul style="list-style-type: none"> <li>■ New parameter PH-E</li> <li>■ Altered factory settings for SI-A and AM-B</li> <li>■ Characteristics for FE-B, CU-A and CR-A extended</li> <li>■ Measuring range limitation increased to 50000 for all parameters and engineering units</li> <li>■ Calibration value can be adjusted to end of measuring range</li> </ul>	BA356C/07/xx/07.06
06/2005	5.7	Improvement <ul style="list-style-type: none"> <li>■ Stack overflow eliminated</li> <li>■ FE-C valve control corrected</li> <li>■ RTC properly dealt with when setting/reading the time</li> </ul>	-
07/2004	5.6	Extension <ul style="list-style-type: none"> <li>■ Range of adjustment for delay to sample to 999s</li> <li>■ Range of adjustment for cleaning duration to 300s</li> <li>■ Range of adjustment for frequencies to 5800 Hz</li> <li>■ Factory settings accepted as specified</li> <li>■ Altered measuring cycles for AM-D, AL-A (like hardness)</li> </ul>	BA353C/07/xx/09.04 BA357C/07/xx/10.04
05/2004	5.5	Extension/improvement <ul style="list-style-type: none"> <li>■ Longer initialization</li> <li>■ Altered measuring cycle for SI</li> <li>■ Shortened reaction time, AM-C (90 s)</li> <li>■ SI-A: 0 Hz signal error only after 90 s</li> <li>■ Reason for crashing during frequency display in SERVICE eliminated</li> <li>■ Restart after power failure</li> </ul>	BA364C/07/xx/06.04
03/2004	5.4	Extension/improvement <ul style="list-style-type: none"> <li>■ New process: HA</li> <li>■ Menu extension: Cell drain time</li> <li>■ Calibration valve off during reaction</li> <li>■ Hungarian and Spanish no longer available</li> <li>■ New hardness engineering units</li> <li>■ New standard parameters/factory settings</li> <li>■ Stepping motor activation corrected</li> </ul>	BA361C/07/xx/02.04
08/2003	5.3	Improvement <ul style="list-style-type: none"> <li>■ Fault elimination for measuring range switchover, HA</li> </ul>	-
08/2003	5.2	Extension/improvement <ul style="list-style-type: none"> <li>■ Factory settings for SI changed</li> <li>■ CL characteristic changed</li> <li>■ New startup message</li> <li>■ Fault elimination for output for current output, two-channel</li> </ul>	-
05/2003	5.1	Extension/improvement <ul style="list-style-type: none"> <li>■ New parameter CL</li> <li>■ Memory correction</li> <li>■ Time for "Delay to sample" is used for zero measurement</li> <li>■ Factory settings for MN, SI, HA changed</li> </ul>	BA354C/07/07.03
12/2002	5.0	Original software	BA353C/07/xx/01.03 BA355C/07/xx/01.03 BA356C/07/xx/01.03 BA357C/07/xx/01.03 BA358C/07/xx/01.03 BA359C/07/xx/01.03 BA360C/07/xx/01.03 BA361C/07/xx/01.03 BA362C/07/xx/01.03 BA363C/07/xx/01.03 BA364C/07/xx/07.03

## 9.6 Return

The device must be returned if repairs or a factory calibration are required, or if the wrong device has been ordered or delivered. According to legal regulations, Endress+Hauser, as an ISO-certified company, is required to follow certain procedures when handling returned products that are in contact with medium.

To ensure swift, safe and professional device returns, please read the return procedures and conditions on the internet site:

[www.services.endress.com/return-material](http://www.services.endress.com/return-material)

## 9.7 Disposal

The device contains electronic components and must therefore be disposed of in accordance with regulations on the disposal of electronic waste.

Please observe local regulations.

## 10 Technical data

### 10.1 Input

**Measured variable** NH<sub>4</sub>-N [mg/l or µg/l]

**Measuring range**

**AM-A**  
0.02 to 5 mg/l (0.02 to 5 ppm)

**AM-B**  
0.2 to 15 mg/l (0.2 to 15 ppm)

**AM-C**  
0.2 to 100 mg/l (0.2 to 100 ppm)

**AM-D**  
1 to 500 µg/l (1 to 500 ppb)

**Wavelength**

**AM-A/B/D**  
660 nm

**AM-C**  
565 nm

**Reference wavelength**

**AM-A/B**  
880 nm

**AM-C**  
810 nm

### 10.2 Output

**Output signal** 0/4 to 20 mA

**Modbus RS485 (optional)**

Signal coding	EIA/TIA-485
Data transmission rate	9600 Baud
Galvanic isolation	Yes
Connectors	Top-hat rail clamp
Bus termination	-

**Signal on alarm** Contacts: 2 limit contacts (per channel), 1 system alarm contact  
optional: end of measurement (with two channel version display of channel no. available)

**Load** max. 500 Ω  
max. 300 Ω (with optional Modbus module)

**Serial interface** RS232-C  
Modbus RS485 (optional)



**Data logger** 1024 data pairs per channel with date, time and measured value  
100 data pairs with date, time and measured value for calibration factor determination (diagnostic tool)

**Load capacity** 230 V / 115 V AC max. 2 A, 30 V DC max. 1 A

**Protocol specific data**

Protocol	RTU
Function codes	03 (Read holding registers)
Broadcast support for function codes	-
Output data	1 main measured value at address 40008 (2 bytes)
Data format	16 bits
Input data	-
Supported features	Slave address, data format, check sum and baudrate can be configured using Advantech ADAM Utility Software at re-boot with set init switch

### 10.3 Power supply

**Supply voltage** 115 V AC / 230 V AC  $\pm 10\%$ , 50/60 Hz

**Power consumption** approx. 150 VA

**Current consumption** approx. 0.2 A at 230 V  
approx. 0.5 A at 115 V

**Fuses** 1 x slow-blow 0.5 A for electronics  
2 x semi-delay 0.2 A for photometer  
1 x slow-blow 0.1 A for motors  
1 x slow-blow 1 A for fan

### 10.4 Performance characteristics

**Time between two measurements**  $t_{mes}$  = reaction time + rinse time + waiting time + rinse again time + filling time + sampling time + reagent refusal time (min. waiting time = 0 min)

**Maximum measured error**  $\pm 2\%$  of measuring range end

#### 10.4.1 Repeatability

**AM-A:**up to 2 mg/l:  $\pm 0.03$  mg/l ( $\pm 0.03$  ppm)> 2 mg/l:  $\pm 0.1$  mg/l ( $\pm 0.1$  ppm)**AM-B:**up to 5 mg/l:  $\pm 0.05$  mg/l ( $\pm 0.05$  ppm)> 5 mg/l:  $\pm 0.1$  mg/l ( $\pm 0.1$  ppm)**AM-C:**up to 40 mg/l:  $\pm 0.5$  mg/l ( $\pm 0.5$  ppm)> 40 mg/l:  $\pm 2$  mg/l ( $\pm 2$  ppm)**AM-D:** $\pm 2$   $\mu$ g/l ( $\pm 2$  ppb)

**Measuring interval**  $t_{\text{meas}}$  to 120 min

**Reaction time**

**AM-A/B:**  
180 s

**AM-C:**  
110 s

**AM-D:**  
600 s

**Sample requirement** 20 ml (0.68 fl.oz.) per measurement

**Reagent requirement**

**AM-A/B/C:**  
2 x 0.5 ml (0.017 fl.oz.)  
2.59 l (0.68 US.gal) per reagent per month with 10 minute measuring interval

**AM-D:**  
2 x 0.4 ml (0.014 fl.oz.)  
0.88 l (0.23 US.gal) per reagent per month with 20 minute measuring interval

**Calibration interval** 0 to 720 h at ambient temperatures < 30 °C (86 °F)  
max. 6 h at ambient temperatures > 30 °C (86 °F)

**Rinse interval** 0 to 720 h

**Rinse time** selectable from 20 to 300 s (standard = 60 s)

**Rinse again time** 30 s

**Filling time**

**AM-A/B:**  
15 s

**AM-C:**  
18 s

**AM-D:**  
40 s

#### 10.4.2 Empty optical cell

**AM-A/B/C**  
 $t_{\text{refusal}} = 0$  s

**AM-D**  
 $t_{\text{refusal}} = 30$  s

### 10.5 Installation

**Mounting location** Installation on a vibration-free wall

## 10.6 Environment

<b>Ambient temperature</b>	5 to 40 °C (40 to 100 °F), avoid strong fluctuations
<b>Humidity</b>	below the condensation limit, installation in usual, clean rooms outdoor installation only possible with protective devices (customer supplied)
<b>Ingress protection</b>	IP 43

## 10.7 Process

<b>Sample temperature</b>	5 to 40 °C (40 to 100 °F)
<b>Sample flow rate</b>	min. 5 ml (0.17 fl.oz.) per min
<b>Consistency of the sample</b>	low solid content (< 50 ppm)
<b>Sample inlet</b>	Unpressurized
<b>pH value of the sample</b>	pH 5 to 9

## 10.8 Mechanical construction

<b>Design, dimensions</b>	see chapter "Installation"	
<b>Weight</b>	GFR housing	approx. 28 kg (62 lbs)
	Stainless steel housing	approx. 33 kg (73 lbs)
	Without housing	approx. 25 kg (55 lbs)
<b>Material</b>	Housing:	Stainless steel 1.4301 (AISI 304) or Glass-fibre reinforced carbon(GFR)
	Front windows:	Polycarbonate
	Endless hose:	C-FLEX, NORPRENE
	Pump hose:	TYGON, Viton
	Valves:	TYGON, silicone

# 11 Appendix

## 11.1 Operating matrix

### One-channel version

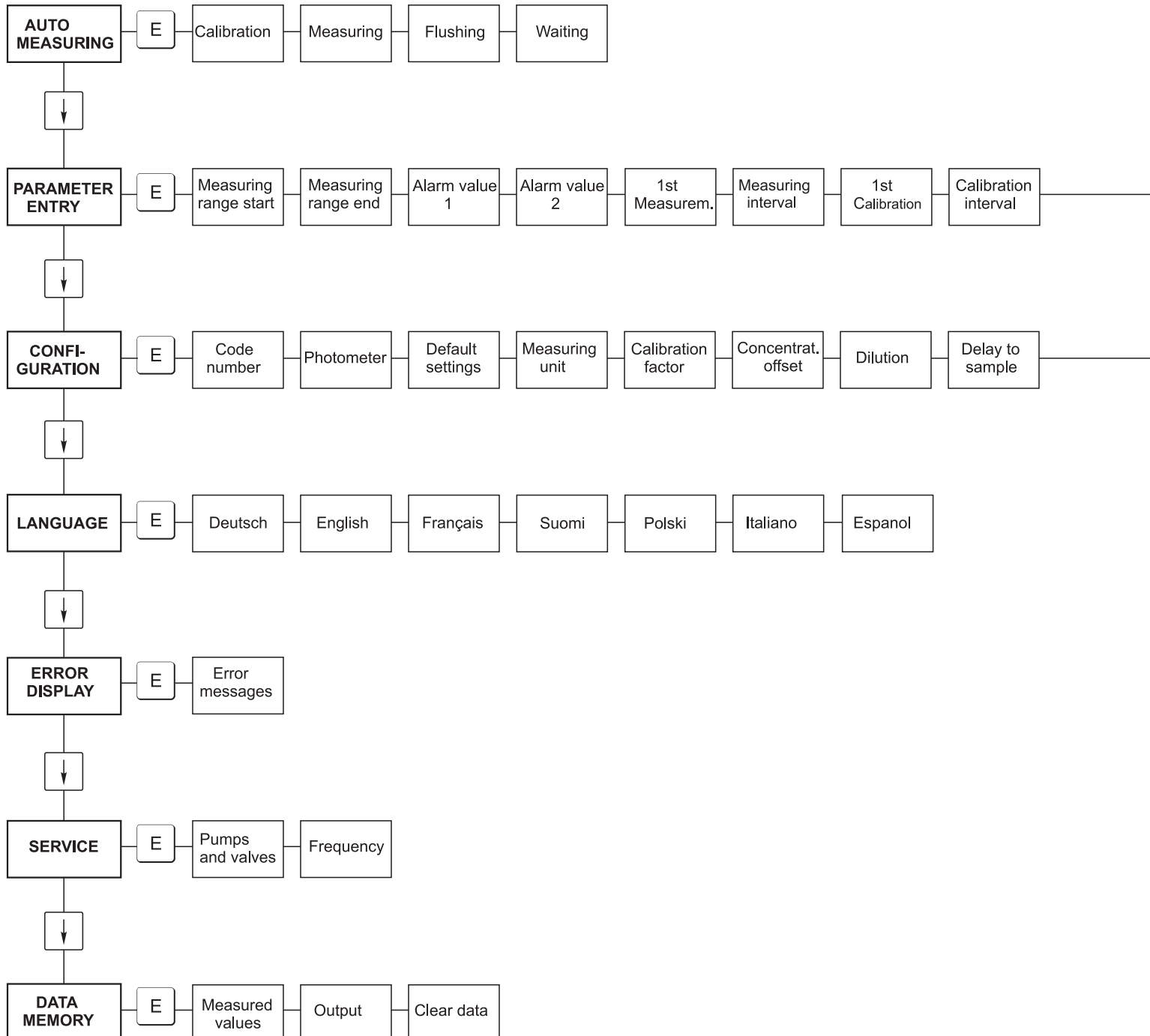

a0001907-en

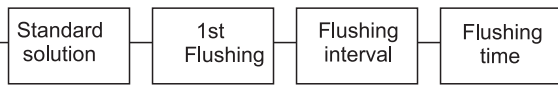

## Two-channel version

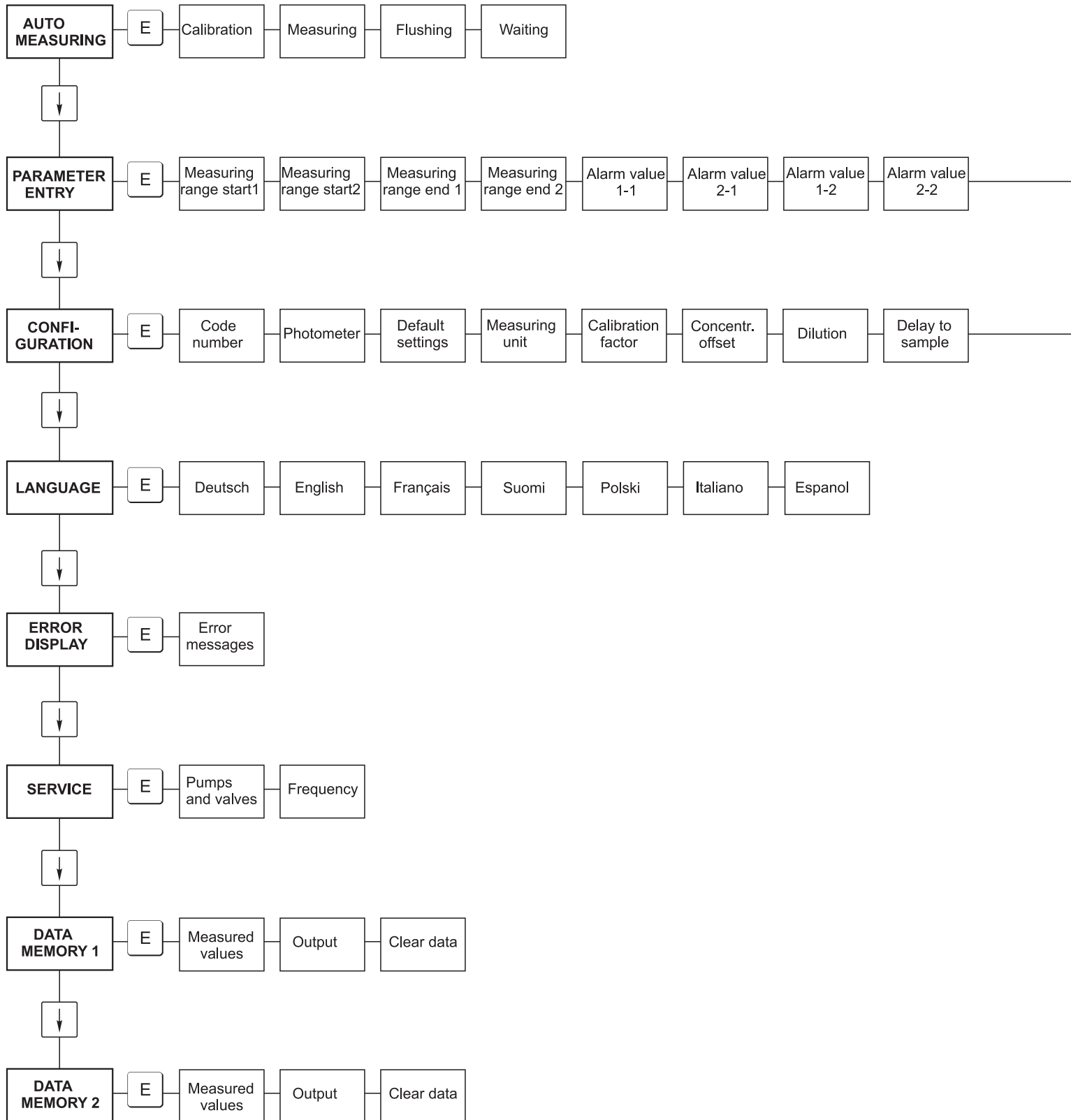

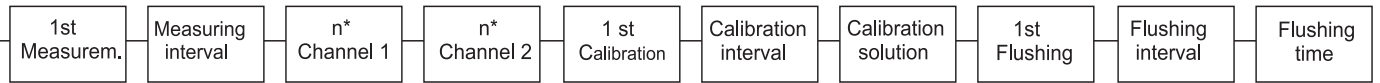

## 11.2 Maintenance schedule

Maintenance schedule for analyser no. ....

### weekly

- Check and note calibration factor
- Visual check (soiling, pump tubings, reagent, sample inlet etc.)
- Move hoses in the valves, change position due to valve pressure, rub in hoses with silicone grease

done	cw 1	cw 2	cw 3	cw 4	cw 5	cw 6	cw 7	cw 8	cw 9	cw 10	cw 11	cw 12
date												
done	cw 13	cw 14	cw 15	cw 16	cw 17	cw 18	cw 19	cw 20	cw 21	cw 22	cw 23	cw 24
date												
done	cw 25	cw 26	cw 27	cw 28	cw 29	cw 30	cw 31	cw 32	cw 33	cw 34	cw 35	cw 36
date												
done	cw 37	cw 38	cw 39	cw 40	cw 41	cw 42	cw 43	cw 44	cw 45	cw 46	cw 47	cw 48
date												
done	cw 49	cw 50	cw 51	cw 52	cw 53							
date												

### 2-weekly

- Check concentration of the calibration factor in the laboratory.  
If necessary, adjust concentration in the menu parameter entry or use new standard.
- Flush sample tubing system with pressurised water (disposable syringe). Remove hose holder unit from the pump.

done	cw 1	cw 3	cw 5	cw 7	cw 9	cw 11	cw 13	cw 15	cw 17	cw 19	cw 21	cw 23
date												
done	cw 25	cw 27	cw 29	cw 31	cw 33	cw 35	cw 37	cw 39	cw 41	cw 43	cw 45	cw 47
date												
done	cw 49	cw 51	cw 53									
date												

### monthly or if required

- Replace reagents.
- Flush the sample tubing system with 12.5% bleaching lye (sodium hypochloride) and reflush thoroughly with water (menu Service V1: P, P1: g, P2: s, V2: S, (two channel version also V3))
- Check sample collector for fouling and clean it if necessary
- Rub in pump hoses with silicone grease.

done	Jan	Feb	Mar	Apr	May	Jun	Jul	Aug	Sep	Oct	Nov	Dec
date												

### monthly / every 6th month

- Turn the pump hoses in the hose holder unit (**monthly/6weekly**), replace them (**every 3th/6th month**)  
**Attention:** *Whenever working on the reagent hoses, the hoses must be removed from the canisters and the T-connectors near the reagent pump to prevent contamination of the reagents.*
- Clean drain lines

done	Jan	Feb	Mar	Apr	May	Jun	Jul	Aug	Sep	Oct	Nov	Dec
date												



# Index

## A

Accessories .....	47
Alarm values .....	28–29
Analog output .....	28
AUTO MEASURING .....	26

## C

Calibration .....	33
Calibration factor .....	27
Calibration interval .....	30, 58
Certificates .....	8
Checking	
Connection .....	24
Function .....	35
Installation .....	16
Cleaner .....	47
Cleaning .....	46
Collecting vessel .....	47
Commissioning .....	4, 35
Dry .....	35
Safety instructions .....	4
Wet .....	37
Concentration offset .....	27
CONFIGURATION .....	27
Connection	
Sample line .....	12
Serial interface .....	23
Signals .....	21
Switching contacts .....	22
Cross referencies .....	5

## D

DATA STORAGE .....	32
Declaration of conformity .....	8
Designated use .....	4
Dilution module .....	37, 48
Display .....	25
Disposal .....	55

## E

Electrical connection .....	17–22
Environment .....	59
ERROR DISPLAY .....	31
Error messages .....	49
Errors .....	49
Process errors .....	50
System errors .....	49

## F

Flushing interval .....	30
Frequency offset .....	28

## G

GFR housing .....	10
-------------------	----

## H

Housing	
GFR .....	10
Stainless steel .....	9
Without .....	11

## I

Icons .....	5
Incoming acceptance .....	9
Input .....	56
Installation .....	4, 9–16, 58
Safety instructions .....	4
Installation examples .....	15
Interference suppressor .....	21
Internet page .....	6

## L

LANGUAGE .....	30
----------------	----

## M

Main menu .....	26
Maintenance .....	40
Schedule .....	40
Maintenance kit .....	47
Measuring unit .....	27
Mechanical construction .....	59
Menu	
Auto Measuring .....	26
Configuration .....	27
Data storage .....	32
Error display .....	31
Language .....	30
Main menu .....	26
Parameter entry .....	29
Service .....	31
Mixer .....	45

## N

Nameplate .....	6
-----------------	---

## O

Offset	
Concentration .....	27
Frequency .....	28
Open version .....	11
Operating matrix .....	60
Operation .....	4, 25
Safety instructions .....	4
Operational safety .....	4
Order code .....	6
Output .....	56

**P**

PARAMETER ENTRY ..... 29

Performance characteristics ..... 57

Photometer optical cell ..... 45

Placing out of service..... 46

Power supply ..... 57

Process ..... 59

Product structure ..... 6

Pump hoses..... 42

Pumps..... 31

**Q**

Quality certificate ..... 8

**R**

Reaching the terminal block..... 17

Reagents ..... 41, 47

Repeatability ..... 57

Replacing

- Mixer ..... 45
- Photometer optical cell..... 45
- Pump hoses ..... 42
- Reagents ..... 41
- Valve hoses ..... 44

Return..... 55

**S**

Safety icons..... 5

Sample line..... 12

Scope of delivery ..... 7

Screening ..... 21

Serial interface..... 23

SERVICE..... 31

Signal connection ..... 21

Software history ..... 53

Spare parts ..... 51

Stainless steel housing..... 9

Standard solution ..... 47

Storage ..... 9

Switching contacts..... 22

Switch-on ..... 35

Symbols ..... 5

**T**

Technical data..... 56

- Environment ..... 59
- Input ..... 56
- Installation..... 58
- Mechanical construction ..... 59
- Output..... 56
- Performance characteristics ..... 57
- Power supply ..... 57
- Process ..... 59

Terminal assignment..... 18

Transport ..... 9

**U**

Use..... 4

**V**

Valve hoses..... 44

Valves ..... 31



[www.endress.com/worldwide](http://www.endress.com/worldwide)

---

**Endress+Hauser**   
People for Process Automation

