

Brief Operating Instructions Ceraphant PTP31B, PTP33B

Process pressure measurement

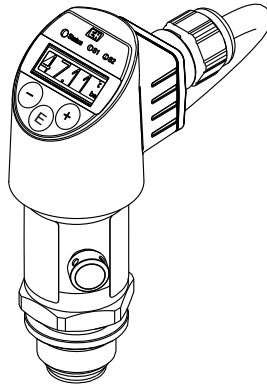

These Instructions are Brief Operating Instructions; they are not a substitute for the Operating Instructions pertaining to the device.

Detailed information about the device can be found in the Operating Instructions and the other documentation:

Available for all device versions via:

- Internet: www.endress.com/deviceviewer
- Smart phone/tablet: *Endress+Hauser Operations App*

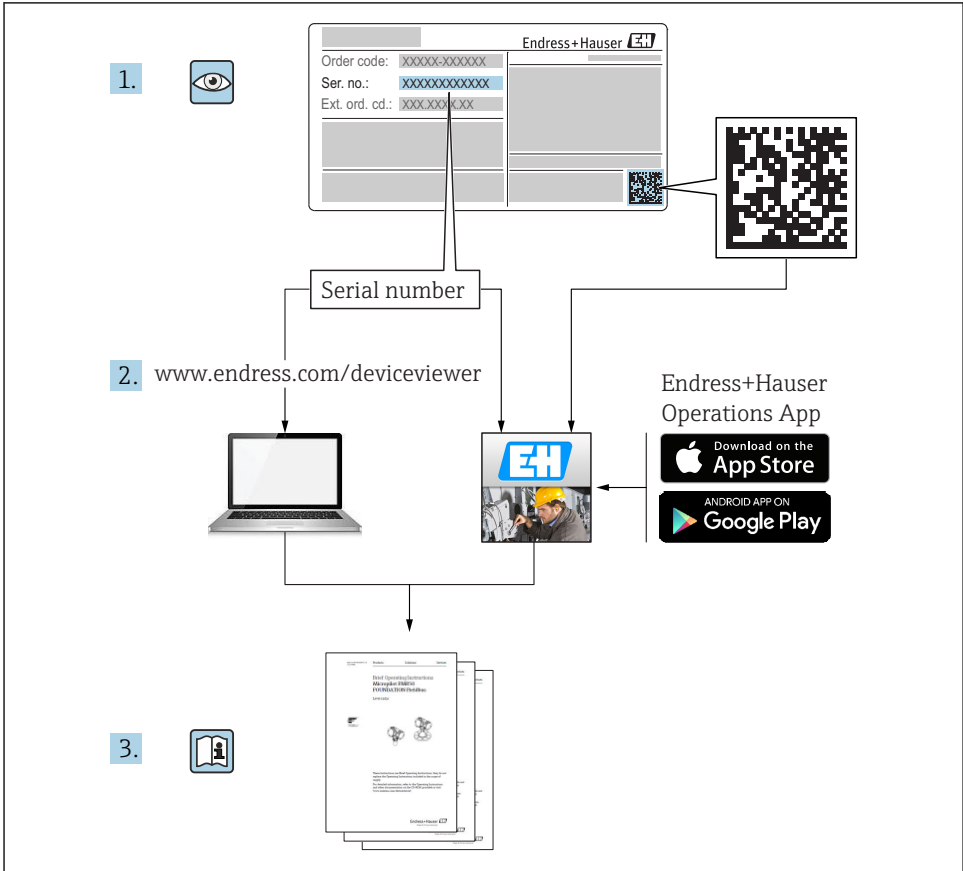

A0023555

Table of contents

1	Document information	5
1.1	Document function	5
1.2	Symbols used	5
1.3	Documentation	6
1.4	Terms and abbreviations	7
1.5	Turn down calculation	8
2	Basic safety instructions	9
2.1	Requirements concerning the staff	9
2.2	Designated use	9
2.3	Workplace safety	9
2.4	Operational safety	10
2.5	Product safety	10
3	Product description	10
4	Incoming acceptance and product identification	11
4.1	Incoming acceptance	11
4.2	Product identification	11
4.3	Storage and transport	12
5	Installation	12
5.1	Installation conditions	12
5.2	Influence of the installation position	13
5.3	Mounting location	13
5.4	Post-installation check	14
6	Electrical connection	15
6.1	Connecting the measuring unit	15
6.2	Relay switching capacity	17
6.3	Connection conditions	17
6.4	Connection data	17
6.5	Post-connection check	18
7	Operation options	19
7.1	Operation with an operating menu	19
7.2	Structure of the operating menu	19
7.3	Operation with local display	19
7.4	General value adjustment and rejection of illegal entries	20
7.5	Navigation and selection from list	21
7.6	Locking and unlocking operation	22
7.7	Navigation examples	23
7.8	Status LEDs	23
7.9	Resetting to factory settings (reset)	24
8	Commissioning	24
8.1	Function check	24
8.2	Enabling configuration/operation	24
8.3	Commissioning with an operating menu	25
8.4	Configuring pressure measurement (only for devices with a current output)	25
8.5	Perform position adjustment	26
8.6	Configuring process monitoring	29
8.7	Functions of switch output	29
8.8	Application examples	33
8.9	Configuring the local display	33
8.10	Protecting settings from unauthorized access	33

9 Overview of the operating menu 33





1 Document information

1.1 Document function



The Brief Operating Instructions contain all the essential information from incoming acceptance to initial commissioning.

1.2 Symbols used

1.2.1 Safety symbols

Symbol	Meaning
	DANGER! This symbol alerts you to a dangerous situation. Failure to avoid this situation will result in serious or fatal injury.
	WARNING! This symbol alerts you to a dangerous situation. Failure to avoid this situation can result in serious or fatal injury.
	CAUTION! This symbol alerts you to a dangerous situation. Failure to avoid this situation can result in minor or medium injury.
	NOTE! This symbol contains information on procedures and other facts which do not result in personal injury.









1.2.2 Electrical symbols

Symbol	Meaning	Symbol	Meaning
	Protective ground connection A terminal which must be connected to ground prior to establishing any other connections.		Ground connection A grounded terminal which, as far as the operator is concerned, is grounded via a grounding system.

1.2.3 Tool symbols

Symbol	Meaning
 A0011222	Open-ended wrench

1.2.4 Symbols for certain types of information

Symbol	Meaning	Symbol	Meaning
	Permitted Procedures, processes or actions that are permitted.		Tip Indicates additional information.
	Forbidden Procedures, processes or actions that are forbidden.		Series of steps
	Reference to documentation		Result of a step
	Reference to graphic		Visual inspection
	Reference to page		

1.2.5 Symbols in graphics

Symbol	Meaning
1, 2, 3 ...	Item numbers
	Series of steps
A, B, C, ...	Views

1.3 Documentation

 The document types listed are available:
In the Download Area of the Endress+Hauser Internet site: www.endress.com → Download

1.3.1 Technical Information (TI): planning aid for your device

PTP31B: TI01130P

PTP33B: TI01246P

The document contains all the technical data on the device and provides an overview of the accessories and other products that can be ordered for the device.

1.3.2 Operating Instructions (BA): your comprehensive reference

BA01270P:

These Operating Instructions contain all the information that is required in various phases of the life cycle of the device: from product identification, incoming acceptance and storage, to mounting, connection, operation and commissioning through to troubleshooting, maintenance and disposal.

1.4 Terms and abbreviations

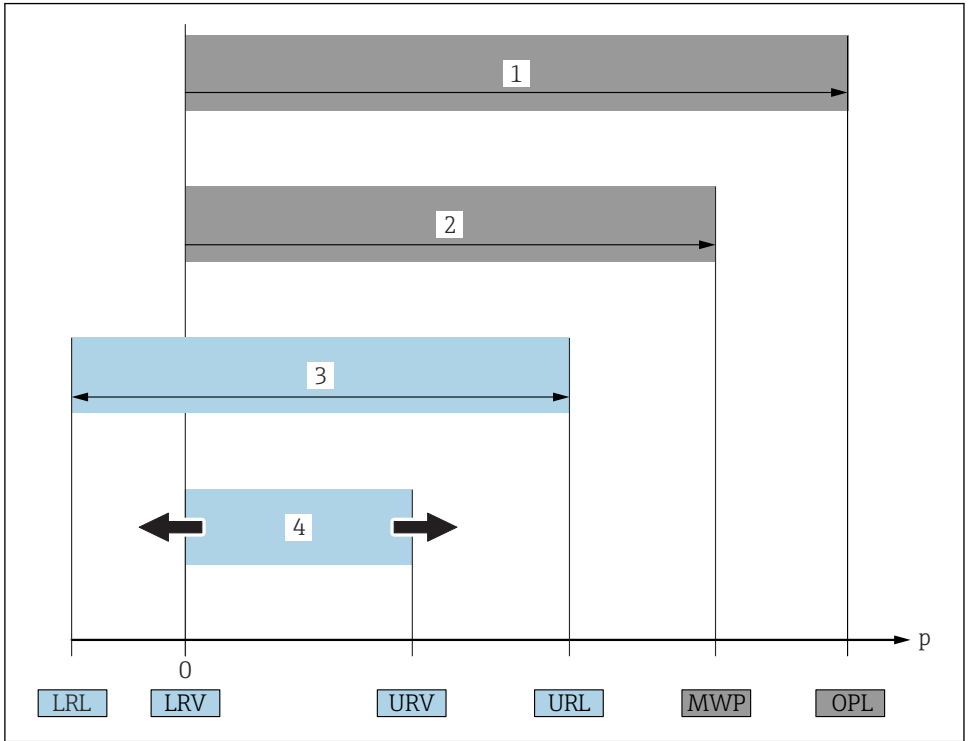

A0029505

Item	Term/ abbreviation	Explanation
1	OPL	The OPL (over pressure limit = sensor overload limit) for the measuring device depends on the lowest-rated element, with regard to pressure, of the selected components, i.e. the process connection has to be taken into consideration in addition to the measuring cell. Also observe pressure-temperature dependency. For the relevant standards and additional notes, see the "Pressure specifications" section of the Operating Instructions . The OPL may only be applied for a limited period of time.
2	MWP	The MWP (maximum working pressure) for the sensors depends on the lowest-rated element, with regard to pressure, of the selected components, i.e. the process connection has to be taken into consideration in addition to the measuring cell. Also observe pressure-temperature dependency. For the relevant standards and additional notes, see the "Pressure specifications" section of the Operating Instructions . The MWP may be applied at the device for an unlimited period. The MWP can also be found on the nameplate.
3	Maximum sensor measuring range	Span between LRL and URL This sensor measuring range is equivalent to the maximum calibratable/adjustable span.

Item	Term/ abbreviation	Explanation
4	Calibrated/adjusted span	Span between LRV and URV Factory setting: 0 to URL Other calibrated spans can be ordered as customized spans.
p	-	Pressure
-	LRL	Lower range limit
-	URL	Upper range limit
-	LRV	Lower range value
-	URV	Upper range value
-	TD (turn down)	Turn down Example - see the following section.

1.5 Turn down calculation

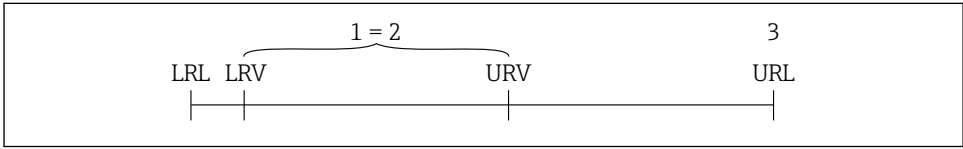

A0029545

- 1 *Calibrated/adjusted span*
- 2 *Zero point-based span*
- 3 *URL sensor*

Example	
<ul style="list-style-type: none"> ▪ Sensor: 10 bar (150 psi) ▪ Upper range value (URL) = 10 bar (150 psi) <p>Turn down (TD):</p> $TD = \frac{URL}{ URV - LRV }$ $TD = \frac{10 \text{ bar (150 psi)}}{ 5 \text{ bar (75 psi)} - 0 \text{ bar (0 psi)} } = 2$ <p>In this example, the TD is 2:1. This span is based on the zero point.</p>	<ul style="list-style-type: none"> ▪ Calibrated/adjusted span: 0 to 5 bar (0 to 75 psi) ▪ Lower range value (LRV) = 0 bar (0 psi) ▪ Upper range value (URV) = 5 bar (75 psi)

2 Basic safety instructions

2.1 Requirements concerning the staff

The staff must fulfill the following requirements for their tasks:

- ▶ Trained staff: Must have a qualification which corresponds to their function and tasks.
- ▶ Authorized by the plant operator.
- ▶ Familiar with the national regulations.
- ▶ Before starting their work: Must have read and understood all instructions in the operating manual and supplementary documentation as well as the certificate (depending on the application).
- ▶ Must comply with all instructions and the regulatory framework.

2.2 Designated use

2.2.1 Application and media

The Ceraphant is a pressure switch for measuring and monitoring absolute and gauge pressure in industrial systems. The process-wetted materials of the measuring device must have an adequate level of resistance to the media.

The measuring device may be used for the following measurements (process variables)

- in compliance with the limit values specified under "Technical data"
- in compliance with the conditions that are listed in this manual.

Measured process variable

Gauge pressure or absolute pressure

Calculated process variable

Pressure

2.2.2 Incorrect use

The manufacturer is not liable for damage caused by improper or non-designated use.

Verification for borderline cases:

- ▶ For special fluids and fluids for cleaning, Endress+Hauser is glad to provide assistance in verifying the corrosion resistance of process-wetted materials, but does not accept any warranty or liability.

2.2.3 Residual risks

When in operation, the housing may reach a temperature close to the process temperature.

Danger of burns from contact with surfaces!

- ▶ For elevated process temperatures, ensure protection against contact to prevent burns.

2.3 Workplace safety

For work on and with the device:

- ▶ Wear the required personal protective equipment according to federal/national regulations.

- ▶ Switch off the supply voltage before connecting the device.

2.4 Operational safety

Risk of injury!

- ▶ Operate the device in proper technical condition and fail-safe condition only.
- ▶ The operator is responsible for interference-free operation of the device.

Conversions to the device

Unauthorized modifications to the device are not permitted and can lead to unforeseeable dangers.

- ▶ If, despite this, modifications are required, consult with Endress+Hauser.

Hazardous area

To eliminate the risk of danger to persons or the facility when the device is used in the approval-related area (e.g. pressure equipment safety):

- ▶ Check the nameplate to verify if the device ordered can be put to its intended use in the approval-related area.

2.5 Product safety

This measuring device is designed in accordance with good engineering practice to meet state-of-the-art safety requirements, has been tested, and left the factory in a condition in which it is safe to operate.

It meets general safety standards and legal requirements. It also complies with the EU directives listed in the device-specific EU Declaration of Conformity. Endress+Hauser confirms this by affixing the CE mark to the device.

3 Product description

See Operating Instructions.

4 Incoming acceptance and product identification

4.1 Incoming acceptance

- Is the order code on the delivery note (1) identical to the order code on the product sticker (2)?
- Are the goods undamaged?
- Do the data on the nameplate correspond to the order specifications and the delivery note?
- If required (see nameplate): Are the safety instructions (XA) present?
- Is the documentation available?



If one of these conditions does not apply, please contact your Endress+Hauser sales office.

4.2 Product identification

The following options are available for identification of the measuring device:

- Nameplate specifications
- Order code with breakdown of the device features on the delivery note
- Enter serial numbers from nameplates in *W@M Device Viewer* (www.endress.com/deviceviewer): All information about the measuring device is displayed.

For an overview of the technical documentation provided, enter the serial number from the nameplates in the *W@M Device Viewer* (www.endress.com/deviceviewer)

4.2.1 Nameplate

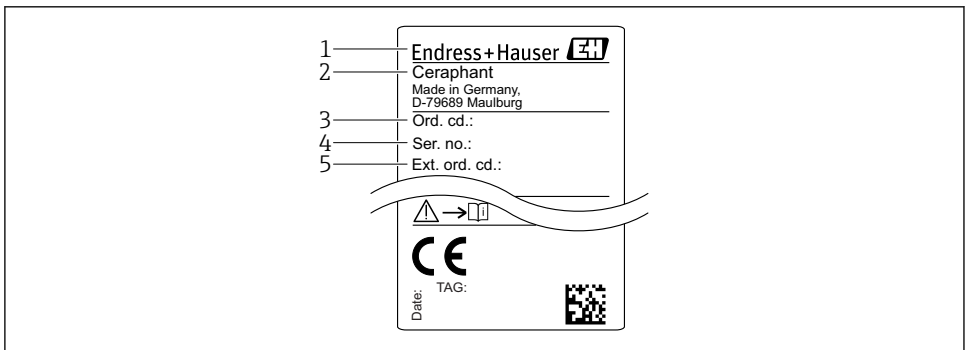

A0030101

- 1 *Manufacturer's address*
- 2 *Device name*
- 3 *Order number*
- 4 *Serial number*
- 5 *Extended order number*

4.3 Storage and transport

4.3.1 Storage conditions

Use original packaging.

Store the measuring device in clean and dry conditions and protect from damage caused by shocks (EN 837-2).

Storage temperature range

-40 to +85 °C (-40 to +185 °F)

4.3.2 Transporting the product to the measuring point

⚠ WARNING

Incorrect transport!

Housing and diaphragm may become damaged, and there is a risk of injury!

- ▶ Transport the measuring device to the measuring point in its original packaging or by the process connection.

5 Installation

5.1 Installation conditions

- No moisture may enter the housing when installing or operating the device, or when establishing the electrical connection.
- Do not clean or touch process isolating diaphragms with hard and/or pointed objects.
- Do not remove the protector on the process isolating diaphragm until just before installation.
- Always firmly tighten the cable entry.
- Point the cable and connector downwards where possible to prevent moisture from entering (e.g. rain or condensation water).
- Protect the housing from impact
- The following instruction applies for devices with a gauge pressure sensor and M12 plug or valve plug:

NOTICE

If a heated device is cooled during the cleaning process (e.g. by cold water), a vacuum develops for a short time, whereby moisture can penetrate the sensor through the pressure compensation element (1).

Device could be destroyed!

- ▶ In this case, mount the device with the pressure compensation element (1) pointing diagonally downwards where possible or to the side.

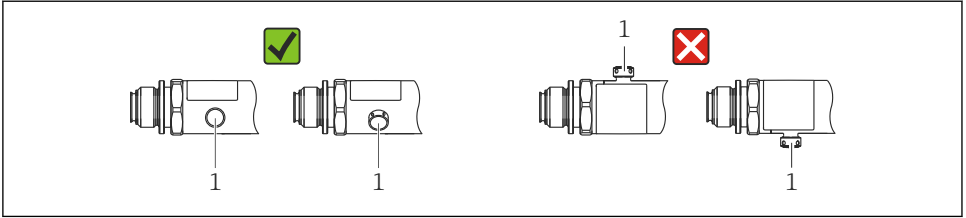

A0022252

5.2 Influence of the installation position

Any orientation is possible. However, the orientation may cause a zero point shift i.e. the measured value does not show zero when the vessel is empty or partially full.

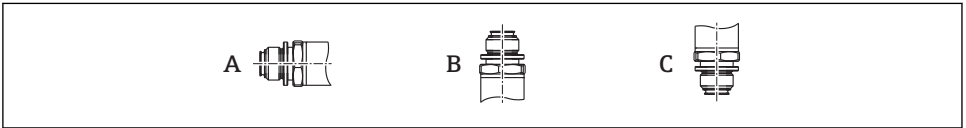

A0024708

Process isolating diaphragm axis is horizontal (A)	Process isolating diaphragm pointing upwards (B)	Process isolating diaphragm pointing downwards (C)
Calibration position, no effect	Up to +4 mbar (+0.058 psi)	Up to -4 mbar (-0.058 psi)



A position-dependent zero shift can be corrected on the device .

5.3 Mounting location

5.3.1 Pressure measurement

Functional testing can be carried out more easily if you mount the device downstream from a shutoff device.

Pressure measurement in gases

Mount the device with shutoff device above the tapping point so that any condensate can flow into the process.

Pressure measurement in vapors

For pressure measurement in vapors, use a siphon. The siphon reduces the temperature to almost ambient temperature. Preferably mount the device with the shutoff device and siphon below the tapping point.

Advantage:

- defined water column causes only minor/negligible measuring errors and
- only minor/negligible heat effects on the device.

Mounting above the tapping point is also permitted.

Note the max. permitted ambient temperature of the transmitter!

Take the influence of the hydrostatic water column into consideration.

Pressure measurement in liquids

Mount the device with a shutoff device and siphon below or at the same height as the tapping point.

Advantage:

- defined water column causes only minor/negligible measuring errors and
- air bubbles can be released to the process.

Take the influence of the hydrostatic water column into consideration.

5.3.2 Level measurement

- Always install the device below the lowest measuring point.
- Do not install the device at the following positions:
 - In the filling curtain
 - In the tank outlet
 - In the suction area of a pump
 - Or at a point in the tank which could be affected by pressure pulses from the agitator.
- Functional testing can be carried out more easily if you mount the device downstream from a shutoff device.

5.4 Post-installation check

<input type="checkbox"/>	Is the device undamaged (visual inspection)?
<input type="checkbox"/>	Does the device conform to the measuring point specifications? For example: <ul style="list-style-type: none"> ■ Process temperature ■ Process pressure ■ Ambient temperature range ■ Measuring range
<input type="checkbox"/>	Are the measuring point identification and labeling correct (visual inspection)?
<input type="checkbox"/>	Is the device adequately protected from precipitation and direct sunlight?
<input type="checkbox"/>	Are the securing screws tightened securely?
<input type="checkbox"/>	Does the pressure compensation element point downwards at an angle or to the side?
<input type="checkbox"/>	To prevent the penetration of moisture: are the connecting cables/plugs pointing downwards?

6 Electrical connection

6.1 Connecting the measuring unit

6.1.1 Terminal assignment

WARNING

Risk of injury from the uncontrolled activation of processes!

- ▶ Switch off the supply voltage before connecting the device.
- ▶ Make sure that downstream processes are not started unintentionally.

WARNING

Limitation of electrical safety due to incorrect connection!

- ▶ In accordance with IEC/EN61010 a separate circuit breaker must be provided for the device .
- ▶ The device must be operated with a 630 mA fine-wire fuse (slow-blow).
- ▶ Protective circuits against reverse polarity are integrated.

NOTICE

Damage to analog input of PLC resulting from incorrect connection

- ▶ Do not connect the active PNP switch output of the device to the 4 to 20 mA input of a PLC.

Connect the device in the following order:

1. Check whether the supply voltage matches the supply voltage indicated on the nameplate.
2. Connect device in accordance with the following diagram.

Switch on supply voltage.

For devices with a cable connection: do not close reference air hose (see (a) in the following drawings)! Protect reference air hose against penetration by water/condensate.

1 x PNP switch output R1

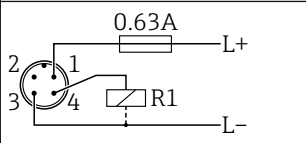
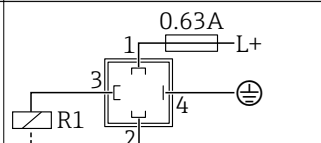
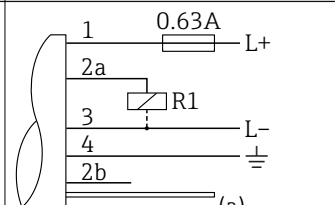
M12 plug	Valve plug	Cable
 <p style="text-align: right;">A0029268</p>	 <p style="text-align: right;">A0023271</p>	 <p style="text-align: right;">A0022801</p> <p>1 brown = L+</p> <p>2a black = switch output 1</p> <p>2b white = not assigned</p> <p>3 blue = L-</p> <p>4 green/yellow = ground</p> <p>(a) reference air hose</p>

2 x PNP switch outputs R1 and R2

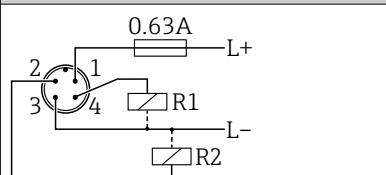
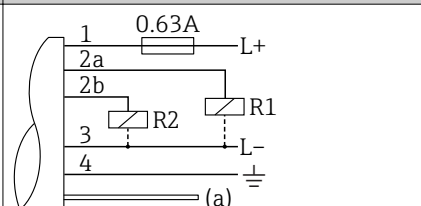
M12 plug	Valve plug	Cable
 <p style="text-align: right;">A0023248</p>	<p style="text-align: center;">-</p>	 <p style="text-align: right;">A0023282</p> <p>1 brown = L+</p> <p>2a black = switch output 1</p> <p>2b white = switch output 2</p> <p>3 blue = L-</p> <p>4 green/yellow = ground</p> <p>(a) reference air hose</p>

1 x PNP switch output R1 with additional analog output 4 to 20 mA (active)

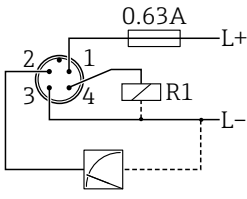
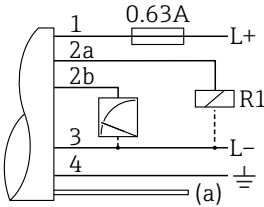
M12 plug	Valve plug	Cable
 <p style="text-align: right;">A0023249</p>	-	 <p style="text-align: right;">A0030519</p> <p>1 brown = L+</p> <p>2a black = switch output 1</p> <p>2b white = analog output 4 to 20 mA</p> <p>3 blue = L-</p> <p>4 green/yellow = ground</p> <p>(a) reference air hose</p>

6.1.2 Supply voltage

Supply voltage: 10 to 30 V DC

6.1.3 Current consumption and alarm signal

Intrinsic power consumption	Alarm current (for devices with analog output)
≤ 60 mA	≥ 21 mA (factory setting)

6.2 Relay switching capacity

- Switch state ON: $I_a \leq 250$ mA; switch state OFF: $I_a \leq 1$ mA
- Switch cycles: >10,000,000
- Voltage drop PNP: ≤ 2 V
- Overload protection: Automatic load testing of switching current;
 - Max. capacitance load: 14 μF at max. supply voltage (without resistive load)
 - Max. cycle duration: 0.5 s; min. t_{on} : 4 ms
 - Periodic disconnection from protective circuit in the event of overcurrent ($f = 2$ Hz) and "F804" display

6.3 Connection conditions

6.3.1 Cable specification

For valve plug: < 1.5 mm² (16 AWG) and Ø3.5 to 6.5 mm (0.14 to 0.26 in)

6.4 Connection data

6.4.1 Load (for devices with analog output)

The maximum load resistance depends on the terminal voltage and is calculated according to the following formula:

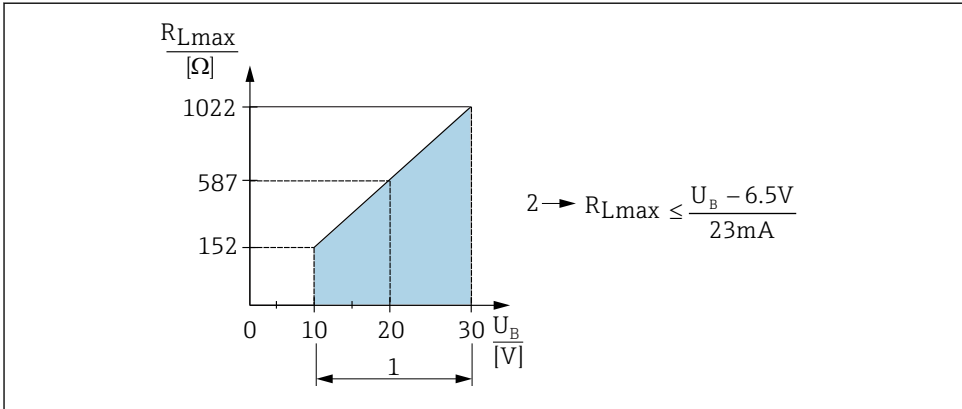

A0031107

- 1 Power supply 10 to 30 V DC
 2 R_{Lmax} maximum load resistance
 U_B Supply voltage

When excessively high load:

- Output of the fault current and display of "S803 "
- Periodic review whether error condition may be left

6.5 Post-connection check

<input type="checkbox"/>	Is the device or cable undamaged (visual check)?
<input type="checkbox"/>	Do the cables comply with the requirements ?
<input type="checkbox"/>	Do the cables have adequate strain relief?
<input type="checkbox"/>	Are all the cable glands installed, firmly tightened and leak-tight?
<input type="checkbox"/>	Does the supply voltage match the specifications on the nameplate?
<input type="checkbox"/>	Is the terminal assignment correct ?
<input type="checkbox"/>	If required: Has protective ground connection been established ?
<input type="checkbox"/>	If supply voltage is present, is the device ready for operation and do values appear on the display module or is the green LED lit on the electronic insert?

7 Operation options

7.1 Operation with an operating menu

7.1.1 Operating concept

Operation with an operating menu is based on an operation concept with "user roles".

User role	Meaning
Operator (display level)	Operators are responsible for the devices during normal "operation". This is usually limited to reading process values either directly at the device or in a control room. Should an error occur, these users simply forward the information on the errors but do not intervene themselves.
Maintenance (user level)	Service engineers usually work with the devices in the phases following device commissioning. They are primarily involved in maintenance and troubleshooting activities for which simple settings have to be made at the device. Technicians work with the devices over the entire life cycle of the product. Thus, commissioning and advanced settings and configurations are some of the tasks they have to carry out.

7.2 Structure of the operating menu

The menu structure has been implemented according to VDMA 24574-1 and complemented by Endress+Hauser-specific menu items.

User role	Submenu	Meaning/use
Operator (display level)	Display/operat.	Display of measured values, fault and information messages
Maintenance (user level)	Parameters on the topmost menu level.	Contains all the parameters that are needed to commission measuring operations. A wide range of parameters, which can be used to configure a typical application, is available at the start. After making settings for all these parameters, the measuring operation should be completely configured in the majority of cases.
	EF	The submenu "EF" contains additional parameters which allow more accurate configuration of the measurement, conversion of the measured value and scaling of the output signal.
	DIAG	Contains all the parameters that are needed to detect and analyze operating errors.



For an overview of the entire operating menu, see the Operating Instructions

7.3 Operation with local display

7.3.1 Overview

A 1-line liquid crystal display (LCD) is used for display and operation. The local display shows measured values, fault messages and information messages and therefore supports the user through each operating step.

The display is fixed to the housing and the values can be rotated electronically by 180° (see parameter description for "DRO"). This ensures optimum readability of the local display and allows the device to be mounted upside down also.

During measuring operation, the display shows measured values, fault messages and notice messages. In addition, it is possible to switch to menu mode via the operating keys.

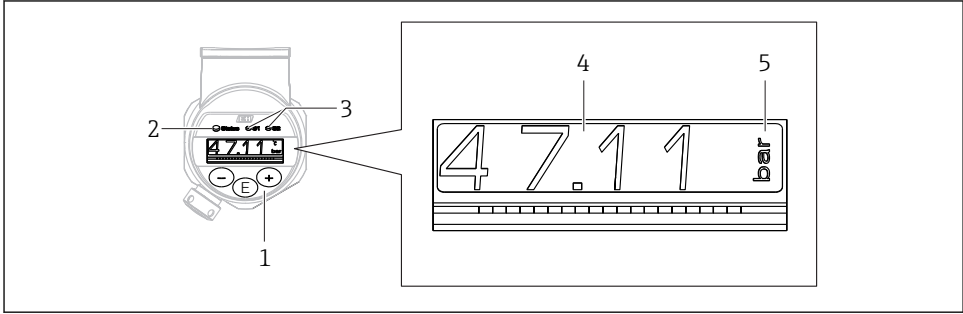

A0022121

- 1 *Operating keys*
- 2 *Status LED*
- 3 *Switch output LEDs*
- 4 *Measured value*
- 5 *Unit*

7.4 General value adjustment and rejection of illegal entries





Parameter (not numerical value) is flashing: parameter can be adjusted or selected.

When adjusting a numerical value: the numerical value does not flash. The first digit of the numerical value starts to flash only when the E key is pressed by way of confirmation. Enter the desired value with the - or + key and press the E key to confirm. Following confirmation, the data are recorded directly and are active.

- Entry is OK: value is accepted and shown for one second on the display against a white background.
- Entry is not OK: the message "FAIL" appears for one second on the display against a red background. The value entered is rejected. In the event of an incorrect setting which effects the TD, a diagnostic message is issued.

7.5 Navigation and selection from list

The capacitive operating keys are used for navigation in the operating menu and to select an option from a picklist.

Operating key(s)	Meaning
 <small>A0017879</small>	<ul style="list-style-type: none"> ▪ Navigate downwards in the picklist ▪ Edit the numerical values and characters within a function
 <small>A0017880</small>	<ul style="list-style-type: none"> ▪ Navigate upwards in the picklist ▪ Edit the numerical values and characters within a function
 <small>A0017881</small>	<ul style="list-style-type: none"> ▪ Confirm entry ▪ Jump to the next item ▪ Selection of a menu item and activation of edit mode ▪ The key lock function (KYL) is accessed by pressing the key for longer than 2 seconds
<p style="text-align: center;">Simultaneously</p>  and  <small>A0017879</small> <small>A0017880</small>	<p>ESC functions:</p> <ul style="list-style-type: none"> ▪ Exit edit mode for a parameter without saving the changed value. ▪ You are in a menu at a selection level. Each time you press the keys simultaneously, you go up a level in the menu. ▪ Long ESC: press the keys for longer than 2 seconds

7.6 Locking and unlocking operation

The device features

- Automatic key locking
- Parameter settings lock.

Key locking is indicated on the local display by "E > 2".

Locking of the parameter settings is indicated as soon as an attempt is made to change a parameter.

7.6.1 Disabling the key lock

The keys are locked automatically if the device remains at the topmost menu level (display of pressure measurement value) for 60 seconds.

Call up the key lock function (KYL)

1. Press the \boxed{E} key for at least 2 seconds and then release it
2. By confirming with \boxed{E} "ON" is displayed
3. Use $\boxed{+}$ and $\boxed{-}$ to toggle between "ON" and "OFF"
4. Key locking is disabled as soon as \boxed{E} is pressed to confirm "OFF"

The display changes to the main value level (topmost menu level) if the \boxed{E} key is pressed briefly. The display changes to the key locking if the \boxed{E} key is pressed for at least 2 seconds.

If in the case of "KYL", "ON" or "OFF", more than 10 seconds elapse without a key being pressed, you return to the topmost menu level with active key locking.

The function can be accessed anytime outside the main measured value display and within the operating menu, i.e. if the \boxed{E} key is pressed for at least 2 seconds key locking can be performed anytime at any menu item. Locking is effective immediately. If you quit the context menu, you will return to the same point from which key locking was selected.

7.6.2 Locking parameter settings

See Operating Instructions.

7.6.3 Unlocking parameter settings

See Operating Instructions.

7.7 Navigation examples

7.7.1 Parameters with a picklist

Example: Display measured value rotated by 180°

Menu path: EF → DIS → DRO

Press \leftarrow or \rightarrow key until "DRO" is displayed.	<input type="text" value="D R O"/>
Initial setting is "NO" (display not rotated).	<input type="text" value="N O"/>
Press \leftarrow or \rightarrow until "YES" appears (display is rotated by 180°).	<input type="text" value="Y E S"/>
Press \rightarrow to confirm the setting.	<input type="text" value="D R O"/>

7.7.2 User-definable parameters

Example: setting the "TAU" damping parameter.

Menu path: EF → TAU

Press \leftarrow or \rightarrow key until "TAU" is displayed.	<input type="text" value="T A U"/>
Press \rightarrow to set the damping (min. = 0.0 s; max.= 999.9 s).	<input type="text" value="0. 3 0"/>
Press \leftarrow or \rightarrow to go up or down. Press \rightarrow to confirm the entry and to go to the next position.	<input type="text" value="1. 5"/>
Press \rightarrow to quit the setting function and to go to the "TAU" menu item.	<input type="text" value="T A U"/>

7.8 Status LEDs

The Ceraphant also uses LEDs to signal the status:

- Two LEDs indicate the status of the switch outputs
- One LED indicates if the device is switched on or if an error or fault has occurred

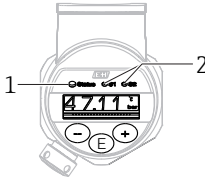

A0032027

- 1 Status LED
2 Switch output LEDs

7.9 Resetting to factory settings (reset)

See Operating Instructions.

8 Commissioning

If an existing configuration is changed, measuring operation continues! The new or modified entries are only accepted once the setting has been made.

⚠ WARNING

Risk of injury from the uncontrolled activation of processes!

- ▶ Make sure that downstream processes are not started unintentionally.

⚠ WARNING

If a pressure smaller than the minimum permitted pressure or greater than the maximum permitted pressure is present at the device, the following messages are output in succession:

- ▶ S971
- ▶ S140
- ▶ F270

8.1 Function check

Before commissioning your measuring point, ensure that the post-installation and post-connection check have been performed:

- "Post-installation check" checklist → 📄 14
- "Post-connection check" checklist → 📄 18





8.2 Enabling configuration/operation

The device features

- Automatic key locking → 📄 22
- Parameter locking → 📄 22.

8.3 Commissioning with an operating menu

Commissioning comprises the following steps:

- Configuration of pressure measurement →  25
- If necessary, perform position adjustment →  26
- If necessary, Configuration of process monitoring if necessary →  29
- If necessary, Configuration of the local display if necessary →  33
- If necessary, Protection of settings from unauthorized access if necessary →  33

8.4 Configuring pressure measurement (only for devices with a current output)

8.4.1 Calibration without reference pressure (dry calibration = calibration without medium)

Example:

In this example, a device with a 400 mbar (6 psi) sensor is configured for the measuring range 0 to 300 mbar (0 to 4.4 psi).

The following values should be assigned:

- 0 mbar = 4 mA value
- 300 mbar (4.4 psi) = 20 mA value

Prerequisite:

This is a theoretical calibration, i.e. the pressure values for the lower and upper range are known. It is not necessary to apply pressure.



Due to the orientation of the device, there may be pressure shifts in the measured value, i.e. the measured value is not zero in a pressureless condition. For information on how to perform position adjustment, see chapter "Perform position adjustment" →  26



Performing the calibration

1. Select a pressure engineering unit via the "UNI" parameter, here "BAR" for example.
Menu path: EF → UNI
2. Select the "STL" parameter. Menu path: STL. Enter the value (0 bar (0 psi)) and confirm.
↳ This pressure value is assigned to the lower current value (4 mA).
3. Select the "STU" parameter. Menu path: STL. Enter the value (300 mbar (4.4 psi)) and confirm.
↳ This pressure value is assigned to the upper current value (20 mA).

The measuring range is configured for 0 to 300 mbar (0 to 4.4 psi).

8.4.2 Calibration with reference pressure (wet calibration = calibration with medium)

Example:



In this example, a device with a 400 mbar (6 psi) sensor is configured for the measuring range 0 to 300 mbar (0 to 4.4 psi).

The following values should be assigned:

- 0 mbar = 4 mA value
- 300 mbar (4.4 psi) = 20 mA value

Prerequisite:

The pressure values 0 mbar and 300 mbar (4.4 psi) can be specified. For example, the device is already installed.

 Due to the orientation of the device, there may be pressure shifts in the measured value, i.e. the measured value is not zero in a pressureless condition. For information on how to perform position adjustment, see chapter "Perform position adjustment" →  26



Performing the calibration

1. Set a pressure engineering unit via the "UNI" parameter, here "BAR" for example.
Menu path: EF → UNI
2. The pressure for the LRV (4 mA value) is present at the device, here 0 bar (0 psi) for example. Select the "GTL" parameter. Menu path: EF → I → GTL. Confirm the present value by selecting "YES".
 - ↳ The present pressure value is assigned to the lower current value (4 mA).
3. The pressure for the URV (20 mA value) is present at the device, here 300 mbar (4.4 psi) for example. Select the "GTU" parameter. Menu path: EF → I → GTU. Confirm the present value by selecting "YES".
 - ↳ The present pressure value is assigned to the upper current value (20 mA).

The measuring range is configured for 0 to 300 mbar (0 to 4.4 psi).

8.5 Perform position adjustment

ZRO manual position adjustment (typically for absolute pressure sensor)

Navigation

EF → ZRO

Description

The pressure resulting from the orientation of the device can be corrected here.

The pressure difference between zero (set point) and the measured pressure must be known.

Prerequisite	<p>An offset is possible (parallel shifting of the sensor characteristic) to correct the orientation and any zero point drift. The set value of the parameter is subtracted from the "raw measured value". The requirement to be able to perform a zero point shift without changing the span is met with the offset function.</p> <p>Maximum offset value = $\pm 20\%$ of the sensor nominal range.</p> <p>If an offset value is entered that shifts the span beyond the physical limits of the sensor, the value is admitted but a warning message is generated and shown on the display. The warning message only disappears when the span is within the sensor limits, taking the offset value currently configured into consideration.</p> <p>The sensor can</p> <ul style="list-style-type: none"> ▪ be operated in a physically unfavorable range, i.e. outside its specifications, or ▪ be operated by making appropriate corrections to the offset or span. <p>Raw measured value – (manual offset) = display value (measured value)</p>
Example	<ul style="list-style-type: none"> ▪ Measured value = 2.2 mbar (0.033 psi) ▪ Set the measured value in the parameter to 2.2. ▪ Measured value (after position adjustment) = 0.0 mbar ▪ The current value is also corrected.
Note	Setting in increments of 0.1. As the value is entered numerically, the increment depends on the measuring range
Selection	No selection. The user is free to edit the values.
Factory setting	0

GTZ automatic position adjustment (typically for gauge pressure sensor)

Navigation EF → GTZ

Description

The pressure resulting from the orientation of the device can be corrected here.

The pressure difference between zero (set point) and the measured pressure need not be known.

Prerequisite

An offset is possible (parallel shifting of the sensor characteristic) to correct the orientation and any zero point drift. The set value of the parameter is subtracted from the "raw measured value". The requirement to be able to perform a zero point shift without changing the span is met with the offset function.

Maximum offset value = $\pm 20\%$ of the sensor nominal range.

If an offset value is entered that shifts the span beyond the physical limits of the sensor, the value is admitted but a warning message is generated and shown on the display. The warning message only disappears when the span is within the sensor limits, taking the offset value currently configured into consideration.

The sensor can

- be operated in a physically unfavorable range, i.e. outside its specifications, or
- be operated by making appropriate corrections to the offset or span.

Raw measured value – (manual offset) = display value (measured value)

Example

Reference pressure : e.g. 980 mbar

- Measured value = 982.2 mbar (14.73 psi)
- You correct the measured value with the value entered (e.g. 2.2 mbar (0.033 psi)) via the "GTZ" parameter. This means that you are assigning the value 980.0 (14.7 psi) to the pressure present.
- Measured value (after pos. zero adjust) = 980.0 mbar (14.7 psi)
- The current value is also corrected.

Factory setting

0.0

8.6 Configuring process monitoring

To monitor the process, it is possible to specify a pressure range which is monitored by the limit switch. Depending on the device version, the process can be monitored using one PNP switch output, or optionally using a second PNP switch output or an analog 4 to 20 mA output. Both monitoring versions are described below. The monitoring function allows the user to define optimum ranges for the process (with high yields etc.) and deploy limit switches to monitor the ranges.

8.6.1 Digital process monitoring (switch output)

It is possible to select defined switch points and switchback points which act as NO or NC contacts depending on whether a window function or hysteresis function is configured

→  29.

Function	Output	Abbreviation for operation
Hysteresis	Closing	HNO
Hysteresis	NC contact	HNC
Window	Closing	FNO
Window	NC contact	FNC

8.6.2 Analog process monitoring (4 to 20 mA output)

- The 3.8 to 20.5 mA signal range is controlled according to NAMUR NE 43.
- The alarm current and current simulation are exceptions:
 - If the defined limit is exceeded, the device continues measuring in a linear fashion. The output current increases linearly up to 20.5 mA and holds the value until the measured value drops below 20.5 mA again or the device detects an error (see the Operating Instructions).
 - If the defined limit is undershot, the device continues measuring in a linear fashion. The output current decreases linearly to 3.8 mA and holds the value until the measured value rises above 3.8 mA again or the device detects an error (see the Operating Instructions).

8.7 Functions of switch output

The switch output can be used for two-point control (hysteresis) or for monitoring a process pressure range (window function).

8.7.1 Hysteresis

SP1/SP2 switch point value, output 1/2

RP1/RP2 switchback point value, output 1/2

Navigation

SP1/SP2
RP1/RP2

Note The hysteresis is implemented using the "SP1/SP2" and "RP1/RP2" parameters. Since the parameter settings depend on one another, the parameters are described all together.

- SP1 = switch output 1
- SP2 = switch output 2 (optional)
- RP1 = switchback point 1
- RP2 = switchback point 2 (optional)

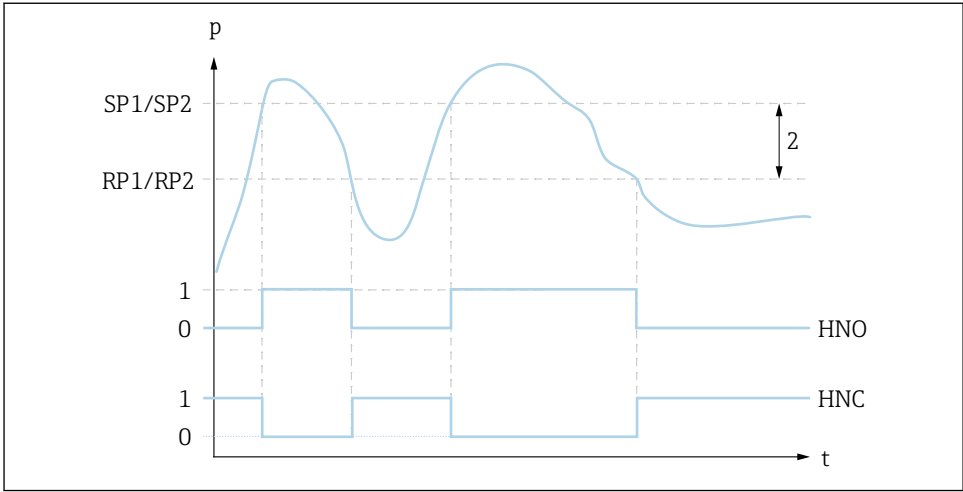

A0022943

1 SP1/SP2: switch point 1/2; RP1/RP2: switch-back point 1/2

0 0-signal. Output open in quiescent state.

1 1-signal. Output closed in quiescent state.

2 Hysteresis

HNO Closing

HNC NC contact

Description

The switch point "SP1/SP2" and the switchback point "RP1/RP2" can be defined with these functions (e.g. for pump control).

When the set switch point "SP1/SP2" is reached (with increasing pressure), an electrical signal change takes place at the switch output.

When the set switchback point "RP1/RP2" is reached (with decreasing pressure), an electrical signal change takes place at the switch output.

The difference between the value of the switch point "SP1/SP2" and the switchback point "RP1/RP2" is known as the hysteresis.

Prerequisite

- These functions are only available if the hysteresis function has been defined for the switch output.
- The configured value for the switch point "SP1/SP2" must be greater than the switchback point "RP1/RP2"! A diagnostic message is displayed if a switch point "SP1/SP2" is entered that is \leq the switchback point "RP1/RP2". While it is possible to make this entry, it does not take effect in the device. The entry must be corrected!

Note

To prevent constant switch-on and switch-off if values are around the switch point "SP1/SP2" and switchback point "RP1/RP2", a delay can be set for the relevant points. See the parameter description for "dS1/dS2" and "dR1/dR2" in the Operating Instructions for this purpose.

Selection

No selection. The user is free to edit the values.

Factory setting

Factory setting (if no customer-specific setting is ordered):
 Switch point SP1: 45 %; switchback point RP1: 44.5 %
 Switch point SP2: 55 %; switchback point RP2: 54.5 %

8.7.2 Window function

- SP1 = switch output 1
- SP2 = switch output 2 (optional)

FH1/FH2 Upper value for pressure window, output 1/2

FL1/FL2 Lower value for pressure window, output 1/2

Navigation

FH1/FH2
 FL1/FL2

Note

The window function is implemented using the "FH1/FH2" and "FL1/FL2" parameters. Since the parameter settings depend on one another, the parameters are described all together.

- FH1 = Upper value of pressure window 1
- FH2 = Upper value of pressure window 2 (optional)
- FL1 = Lower value of pressure window 1
- FL2 = Lower value of pressure window 2 (optional)

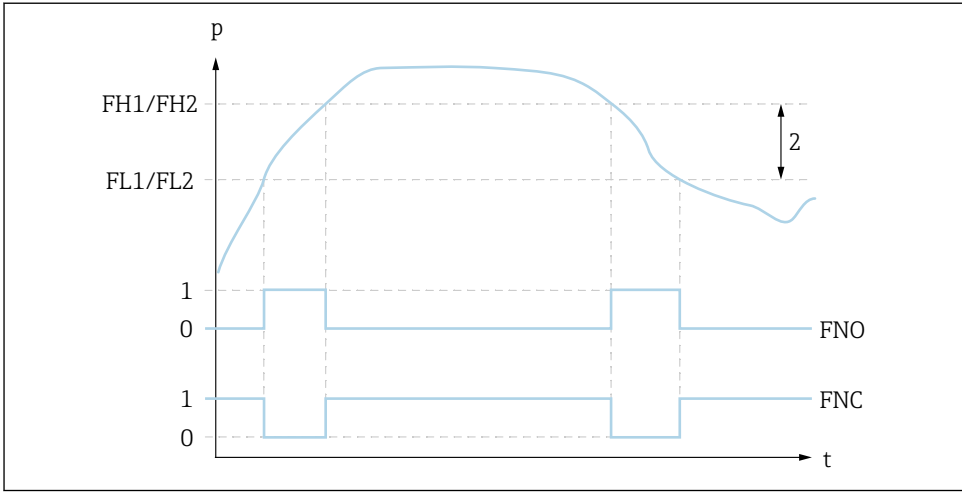

A0027370

2 FH1/FH2: upper value of pressure window; FL1/FL2: lower value of pressure window

0 0-signal. Output open in quiescent state.

1 1-signal. Output closed in quiescent state.

2 Pressure window (difference between the value of the high window "FH1/FH2" and the low window "FL1/FL2")

FNO Closing

FNC NC contact

Description

The upper value of the pressure window "FH1/FH2" and the lower value of the pressure window "FL1/FL2" can be defined with these functions (e.g. for monitoring a certain pressure range).

When the lower value of the pressure window "FL1/FL2" is reached (with increasing or decreasing pressure), an electrical signal change takes place at the switch output.

When the upper value of the pressure window "FH1/FH2" is reached (with increasing or decreasing pressure), an electrical signal change takes place at the switch output. The difference between the upper value of the pressure window "FH1/FH2" and the lower value of the pressure window "FL1/FL2" is known as the pressure window.

Prerequisite

- This function is only available if the window function has been defined for the switch output.
- The upper value of the pressure window "FH1/FH2" must be greater than the lower value of the pressure window "FL1/FL2"!

A diagnostic message is displayed if the upper value entered for the pressure window "FH1/FH2" is smaller than the lower value of the pressure window "FL1/FL2". While it is possible to make this entry, it does not take effect in the device. The entry must be corrected!

Selection

No selection. The user is free to edit the values.

Factory setting

Factory setting if no customer-specific setting is ordered:
 Switch point FH1: 45 %; switchback point FL1: 44.5 %
 Switch point FH2: 55 %; switchback point FH2: 54.5 %

8.8 Application examples

See Operating Instructions.

8.9 Configuring the local display

See Operating Instructions.

8.10 Protecting settings from unauthorized access

See Operating Instructions.

9 Overview of the operating menu

Depending on the parameter configuration, not all submenus and parameters are available. Information on this can be found in the parameter description under "Prerequisite".

Switch output ¹⁾			Level 1	Level 2	Level 3	Description	Details
1 x PNP	2 x PNP	1 x PNP + 4 to 20 mA					
✓	✓	✓	KYL	If "KYL" is shown on the display, this means that the keys of the device are locked. To unlock the keys, see → 22			
✓	✓	✓	SP1			Switch point value, output 1	→ 29
✓	✓	✓	RP1			Switchback point value, output 1	→ 29

Switch output ¹⁾			Level 1	Level 2	Level 3	Description	Details
1 x PNP	2 x PNP	1 x PNP + 4 to 20 mA					
✓	✓	✓	FH1			Upper value for pressure window, output 1	→ ⓘ 31
✓	✓	✓	FL1			Lower value for pressure window, output 1	→ ⓘ 31
		✓	STL			Value for 4 mA (LRV)	
		✓	STU			Value for 20 mA (URV)	
	✓		SP2			Switch point, output 2	→ ⓘ 29
	✓		RP2			Switchback point, output 2	→ ⓘ 29
	✓		FH2			Upper value for pressure window, output 2	→ ⓘ 31
	✓		FL2			Lower value for pressure window, output 2	→ ⓘ 31
✓	✓	✓	EF			Extended functions	
✓	✓	✓	RES			Enter reset code	
				NO		No	
				YES		Yes	
✓	✓	✓	dS1			Switching delay time, output 1	
✓	✓	✓	dR1			Switchback delay time, output 1	
	✓		dS2			Switching delay time, output 2	
	✓		dR2			Switchback delay time, output 2	
✓	✓	✓	Ou1			Output 1	
				HNO		NO contact for hysteresis function	
				HNC		NC contact for hysteresis function	
				FNO		NO contact for window function	
				FNC		NC contact for window function	
	✓		Ou2			Output 2	
				HNO		NO contact for hysteresis function	
				HNC		NC contact for hysteresis function	
				FNO		NO contact for window function	
				FNC		NC contact for window function	
		✓	I			Current output	
		✓	GTL			Pressure applied for 4mA (LRV)	
						NO	
						YES	

Switch output ¹⁾			Level 1	Level 2	Level 3	Description	Details
1 x PNP	2 x PNP	1 x PNP + 4 to 20 mA					
		✓		GTU		Pressure applied for 20mA (URV)	
						NO	
						YES	
		✓		FCU		alarm current	
						MIN	In the event of an error: MIN (≤ 3.6 mA)
						MAX	In the event of an error: MAX (≥ 21 mA)
						HLD	Last current value (HOLD)
		✓		OFF		Switch off the current output (only visible if switch output is "ON")	
						NO	
						YES	
		✓		ON		Switch on the current output (only visible if switch output is "OFF")	
						NO	
						YES	
✓	✓	✓		UNI		Unit changeover	
						BAR	Unit bar
						KPA	Unit kPa (depends on the sensor measuring range)
						MPA	Unit MPa (depends on the sensor measuring range)
						PSI	Unit psi
✓	✓	✓				HI	Max value (maximum indicator)
✓	✓	✓				LO	Min value (minimum indicator)
✓	✓	✓				ZRO	Zero point configuration
✓	✓	✓				GTZ	Zero point adoption
✓	✓	✓				TAU	Damping
✓	✓	✓		DIS		Display	
✓	✓	✓		DVA	PV	Display measured value	
						PV/	Display the measured value as a percentage of the set span
						SP	Display set switch point

Switch output ¹⁾			Level 1	Level 2	Level 3	Description	Details
1 x PNP	2 x PNP	1 x PNP + 4 to 20 mA					
✓	✓	✓		DRO		Display measured value rotated by 180°	
						NO	
						YES	
✓	✓	✓		DOF		Display off	
						NO	
						YES	
✓	✓	✓		ADM		Administration	
					LCK	Unlocking code	
					COD	Locking code	
✓	✓	✓		DIAG		Diagnostics	
					STA	Current device status	
					LST	Last device status	
					RVC	Change counter	
✓	✓	✓		SM1		Simulation output 1	
						OFF	
						OPN	Switch output opened
						CLS	Switch output closed
	✓	✓		SM2 ²⁾		Simulation output 2	
	✓	✓				OFF	
	✓					OPN	Switch output opened
	✓					CLS	Switch output closed
		✓			3.5	Simulation value for analog output in mA	
		✓			4.0	Simulation value for analog output in mA	
		✓			8.0	Simulation value for analog output in mA	
		✓			12.0	Simulation value for analog output in mA	
		✓			16.0	Simulation value for analog output in mA	
		✓			20.0	Simulation value for analog output in mA	
		✓			21.95	Simulation value for analog output in mA	

1) The assignment of the outputs cannot be modified.

2) For devices with current output: can only be selected if the current output is switched on.



71336348

www.addresses.endress.com
