

Density Profile Measurement in the Oil and Gas Industry

Increase the economic efficiency
in separation processes





Density and level measurement in oil and gas processes

Reliability, safety and accuracy The applications and production processes of the oil and gas industry require the highest degree of reliability, safety and efficiency. Operators need detailed production information to control their processes effectively and to increase product quality. The radiometric instrumentation of Endress+Hauser provides a high degree of reliability and accuracy in this respect.

For more than fifty years, we have supplied our instruments and solutions to all large-scale producing industries and have extensive know-how, particularly in oil & gas as well as petrochemical applications. We thus contribute to designing the production processes of our customers more economically efficient. Our product innovations and developments essentially contribute to safer and more economically efficient applications and increase plant availability. Separation processes in refineries or on production platforms constitute tremendous challenges for the availability and economically effective utilization of a plant. Downstream processes and the added value of the entire production depend on the efficient use of upstream separation processes. This requires an accurate and reliable measuring method.

Ideally, users should be well aware of what is happening in the separation tank to enable them to use this information for direct action on the quality of the medium to be produced. This is exactly what we are offering with the radiometric measuring principle.



Interface and density profile measurement In interface monitoring, Endress+Hauser density and interface measurement offers the optimum solution for complete monitoring of interface and emulsion layers of different densities in separation tanks.

Radiometric instrumentation and, in particular, the solution using a Density Profile Measuring System (DPS) offer operators the possibility of getting a view of what is happening in their process by a safe as well as non-invasive and thus process-independent measuring method.

The density profile computer (Profile Vision) visualizes the measuring results simple and clear so that the results can be quickly implemented in further process optimizing and user control.

✓ Advantages Density Profile Measuring System (DPS)

- Optimized and precise process information by continuous density profile measurement and high resolution across the entire measuring range
- Information concerning the density and position of interfaces in one measuring operation
- Complete measuring system of instruments, hardware, software and visualizing
- Easy HMI integration in the higher-ranking process control
- Non-invasive, maintenance-free measuring method
- Easy, space-saving installation of the source container
- No mechanically moved parts

The radiometric instrumentation of Endress+Hauser guarantees the highest degree of safety with different certifications, e.g. SIL and ATEX.

Interface measurement

The measuring principle is based on the fact that the radiation emitted by the radioactive isotope (source) is attenuated as it penetrates material and the medium to be measured. In radiometric interface measurement, the source is inserted into a closed immersion pipe via a rope extension thus preventing any contact between the source and the medium.

Depending on the measuring range and the application, one or several detectors, also called compact transmitters, are assembled on the outside of the tank. The compact transmitter calculates the average density of the medium between source and detector from the radiation received. A direct correlation to the interface may be derived from this density value.

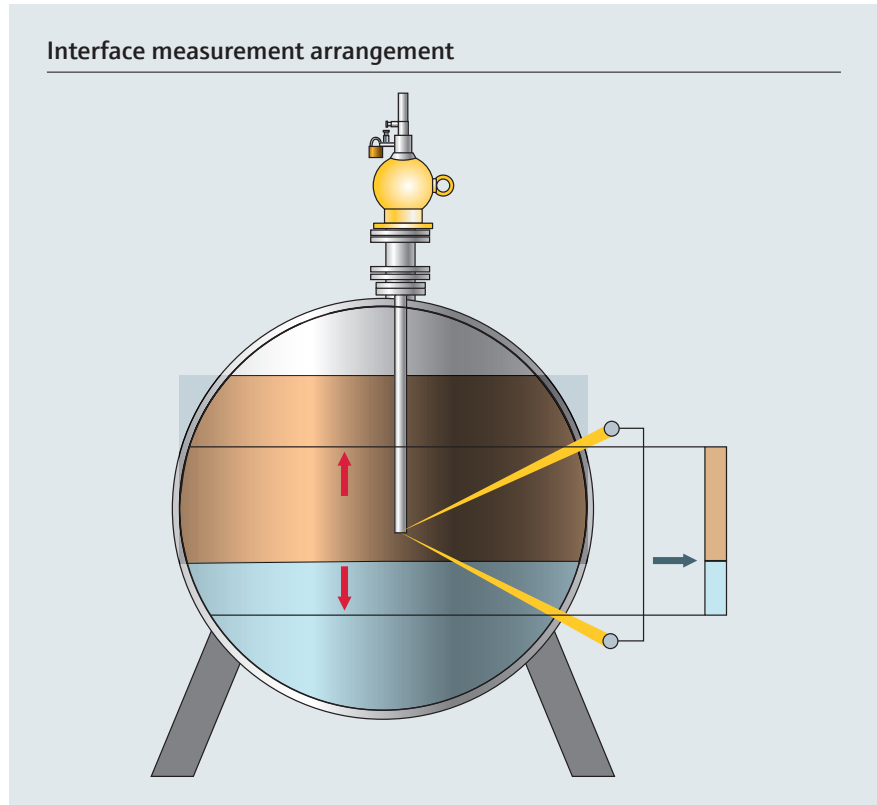

Density profile measurement

To obtain detailed information on the distribution of layers of different densities in a tank, a density profile is measured using a multi-detector solution. Several compact transmitters are installed next to each other on the outside of the tank wall. The measuring range is divided into zones. Each compact transmitter measures the density in its respective zone and a density profile is derived from these values.

With the Density Profile Measuring System (DPS), Endress+Hauser provides a unique solution for the high-resolution measurement of the distribution of layers in separators. Both the continuous operation and maintenance work, for example removal of sand from the tank, can be performed much more efficiently and economically using the Profile Vision design and arrangement.

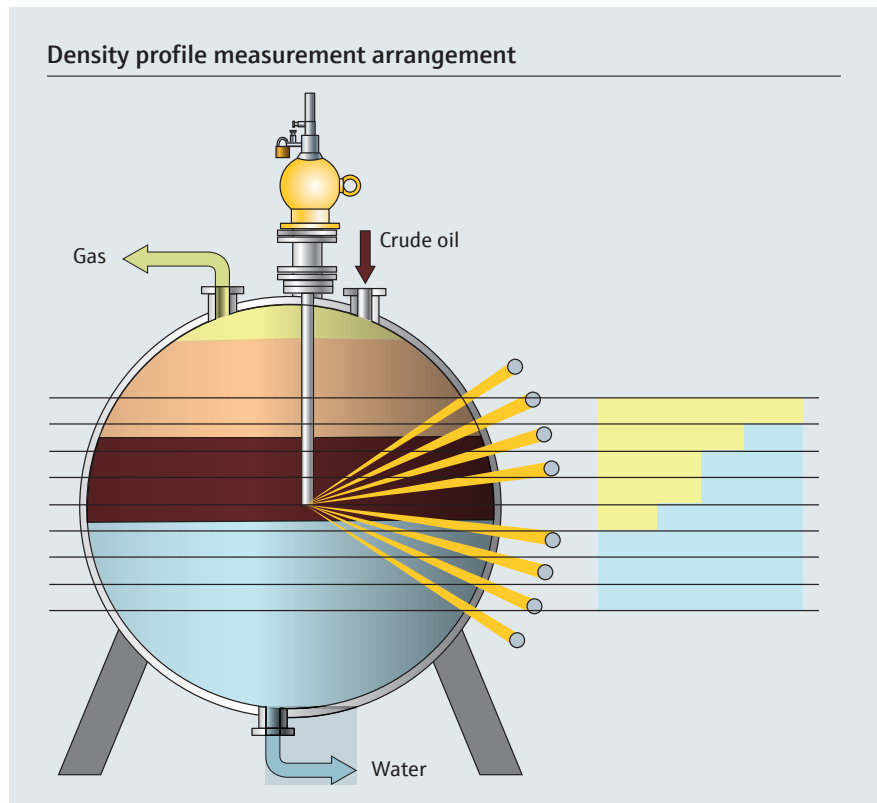

Several measuring systems are individually arranged next to each other to measure the entire separation process within a tank. The respective density profile measurement system is located in the corresponding critical process sections.

The first measurement is taken close to the inlet in order to recognize any sand build-up immediately. To monitor the separation process and the thickness of the emulsion layer, another measurement is taken in the center of the tank. Measuring in front of the weir facilitates optimum control of the flow of oil over the weir.

This 3D profile is the most detailed type of density profile measurement in any separation process.

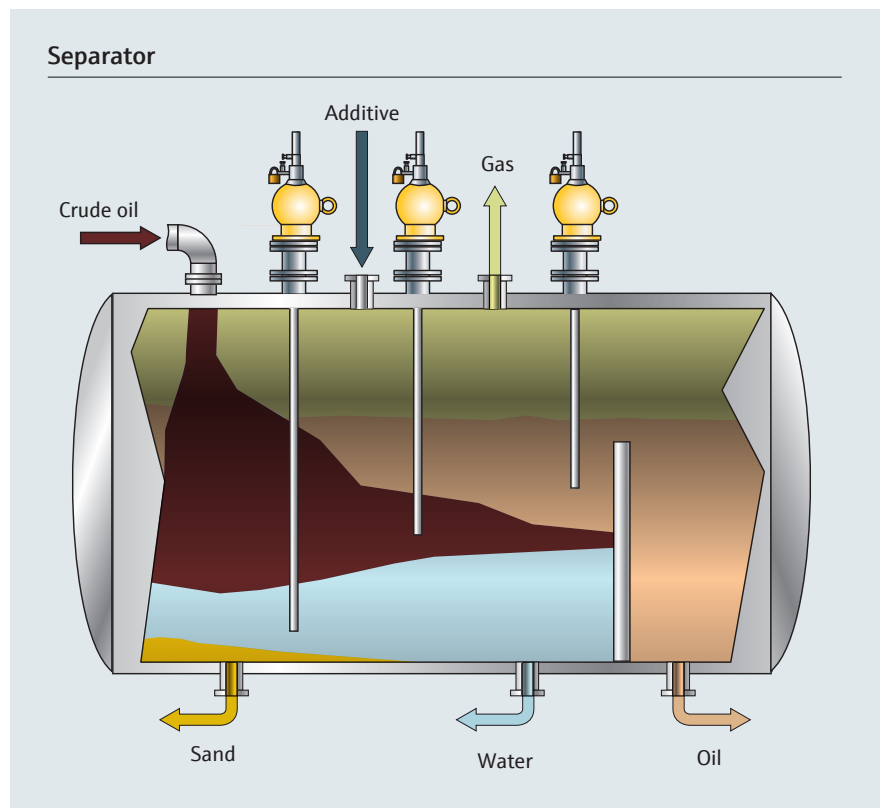

Density profile measurement with 3 sections

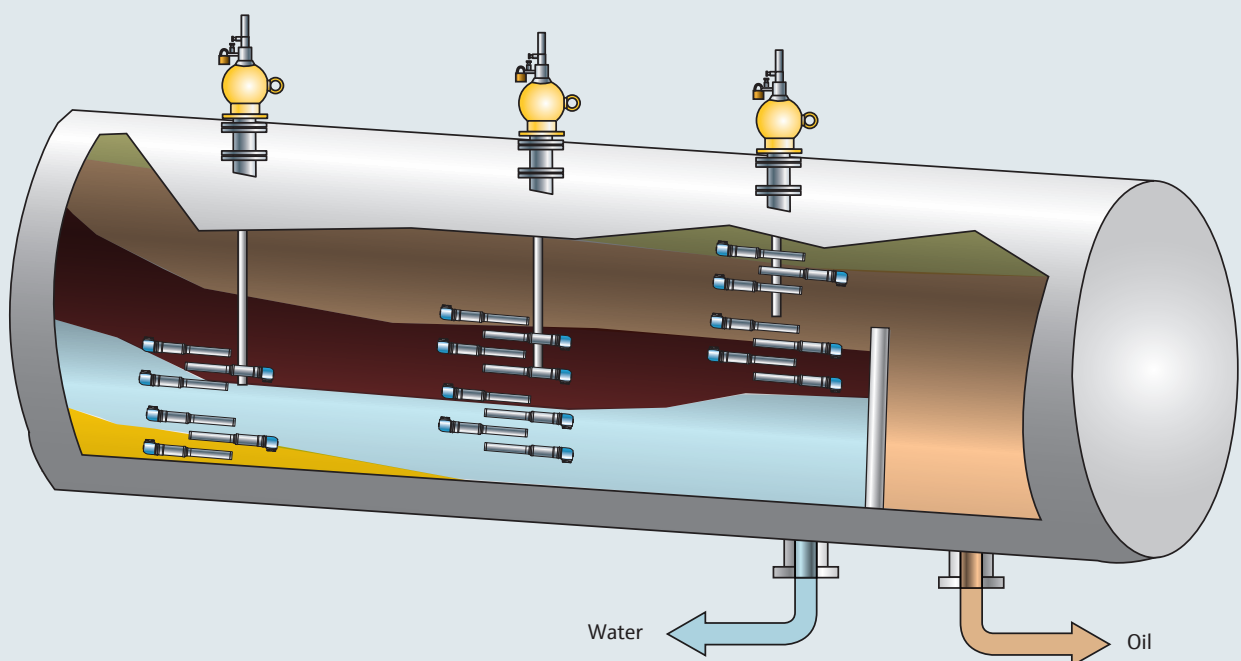

System design

In its density profile measurement, Endress+Hauser offers a complete system of four harmonized components.

Components of the density profile measuring system



Radioactive source FSG60/61

Radioactive isotope with double steel encapsulation complies with the highest classification of sources.

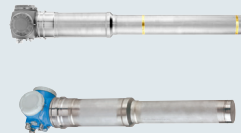

Detector FMG60

The device is composed of a sensor unit and an electronic unit to analyze and transmit the measured values.



Source container FQG63

The FQG63 source container serves as a transport and storage container for radioactive sources.



Density profile calculator "Profile Vision"

Complete system design of density profile measurement

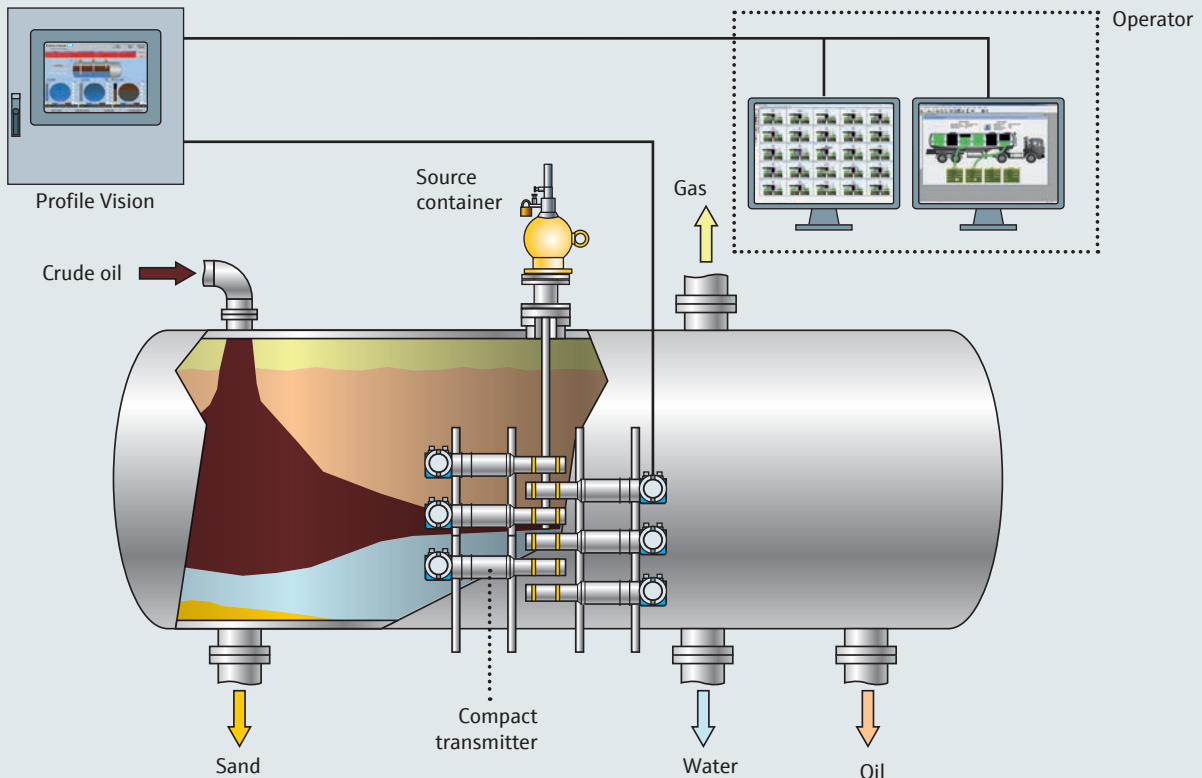

Mechanical design

Source container and immersion pipe The ideal position of the source in the tank is determined. The radioactive source does not come in contact with the medium in the tank. The source is inserted from the source container into the immersion pipe using a rope extension.

The source container is mounted with either a DIN or ANSI flange adapter on the process flange. This ensures that the source container can be readily removed from the process tank and reinstalled without having to interrupt the process. A centering flange is included and permits easy installation and commissioning of the source container.

Detectors The detectors (compact transmitters) are installed on the outside of the tank thus avoiding any contact with the process medium. Easy access to the instruments is ensured at any time – irrespective of the process.

Since the detectors are located directly on the tank, the installation is space-saving and easily accessible. Installation, maintenance and a possible exchange of detectors can be realized during actual operation. There are no mechanically moving parts since the measurement is performed in a stationary and permanent manner within the tank. Reliable and repeatable results are achieved after the first calibration facilitating a diversified perception of the processes within the tank.

Source container with a bent and straight immersion pipe

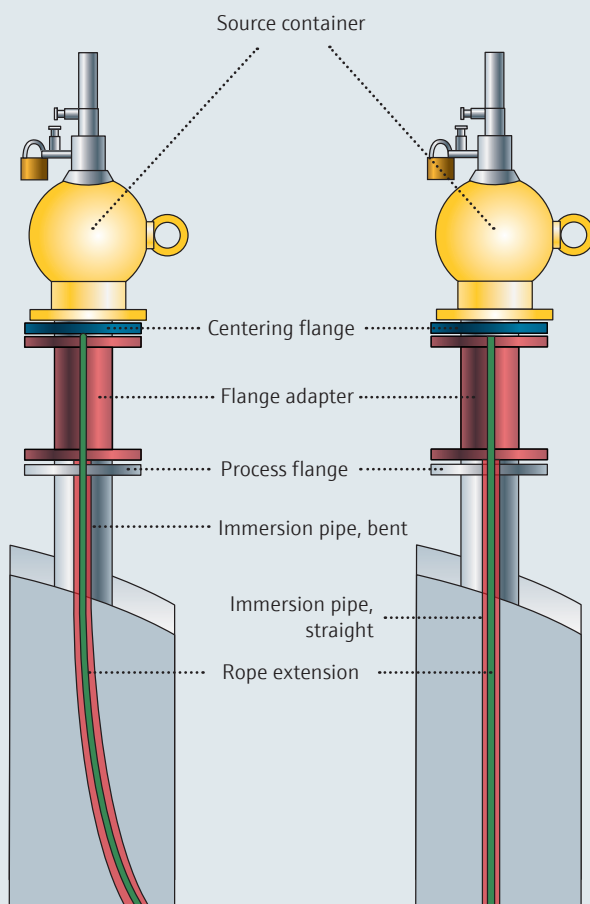

Assembly of detectors directly on the tank

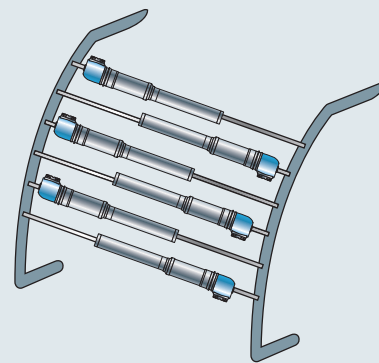

Assembly of detectors using an assembly frame

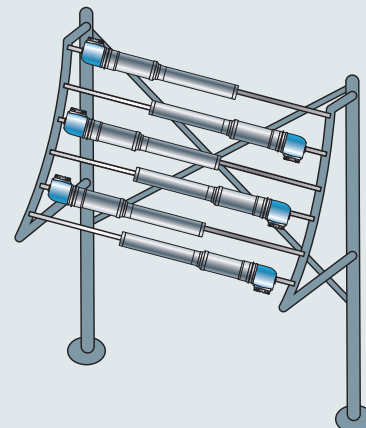

Profile calculator and measuring design

Profile Vision – the profile calculator for the density profile measuring system generates data to visualize the measurement. Threshold values to define the density values are determined in the system. On basis of these values, the interface or emulsion layers are identified. The values may be adapted due to changes of the general setting (e.g. pressure or temperature) at any time. Users can thus react flexibly to changing ambient impacts without having to recalibrate the system.

Profile Vision requires an external power supply and a separate line for the interface to the main control system (SPS, DCS). The data from the density profile calculator is transferred to the control system via any interface.

The power supply of the detectors may be arranged via a main line to the separator. From there, the detectors are connected to the supply via an individual fuse. The detectors communicate with the density calculator via Profibus, HART or FOUNDATION fieldbus. A status message of a device is received by the density calculator and transferred to the control system.

In addition, there is the possibility of writing parameters into the density calculator from the control system. This is an advantage if, for example, the quality of the mixture of oil and water fed into the tank changes and parameters have to be adapted in the visualizing system.

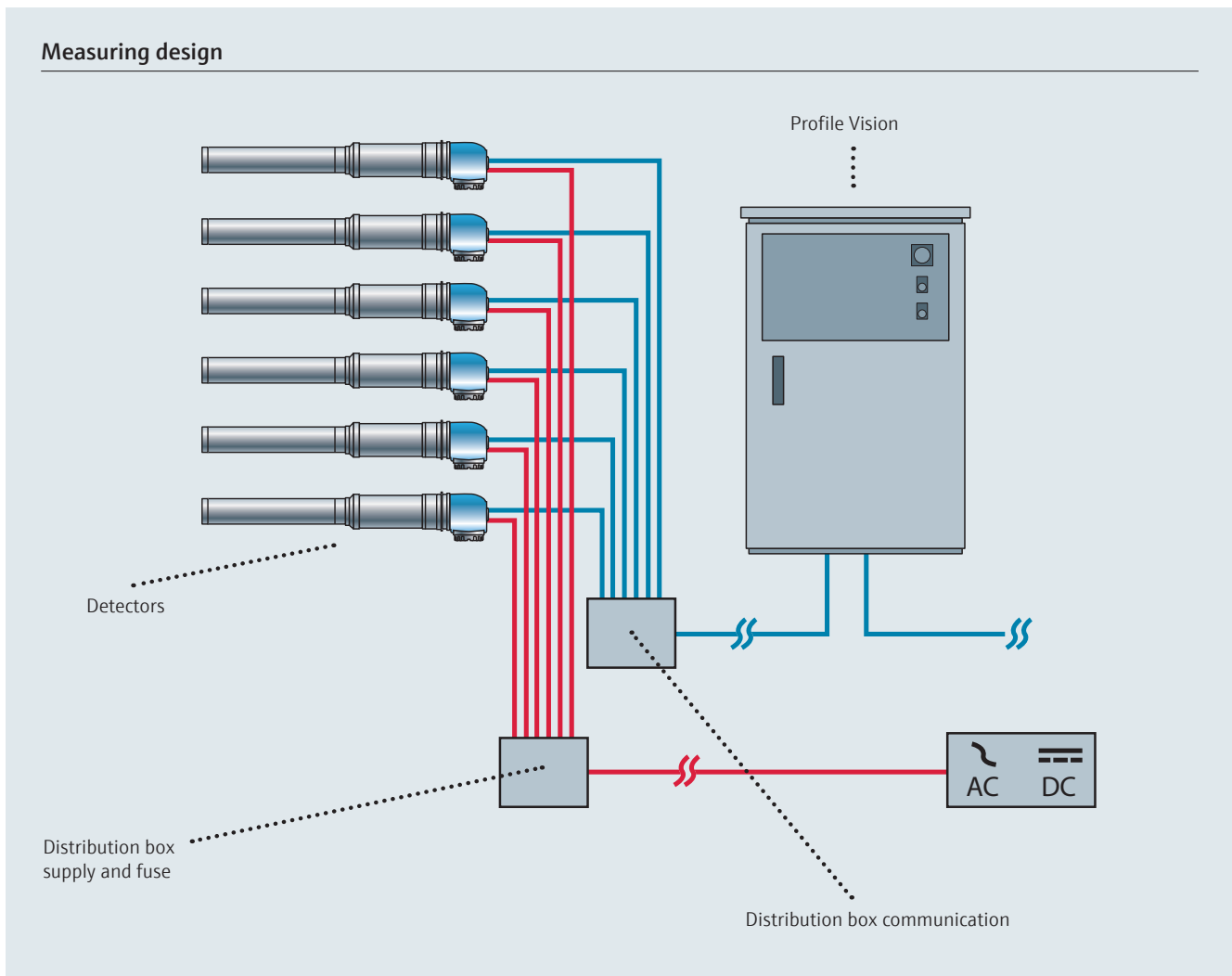

Application examples

Separator, Free Water Knock Out Drum (FWKO) treater

The goal of a separation process is to separate the extracted mixture into its ingredients of sand, sludge, water and oil.

The density profile measurement by Profile Vision permits an essentially more detailed view of the position of respective layers. The position of the emulsion layer provides information on the process. Additives may also be more efficiently controlled by a direct view of the progression of the process in the tank. This contributes considerable to cost saving. Optimizing the separation makes it possible to increase the supply of fresh mixture and thus to raise the productivity of the process.

The improved quality allows downstream processes on a platform or at a refinery to operate in an optimum fashion thus contributing to an improved flow rate, increasing the quality of the final products and raising the economic efficiency of the entire production process.

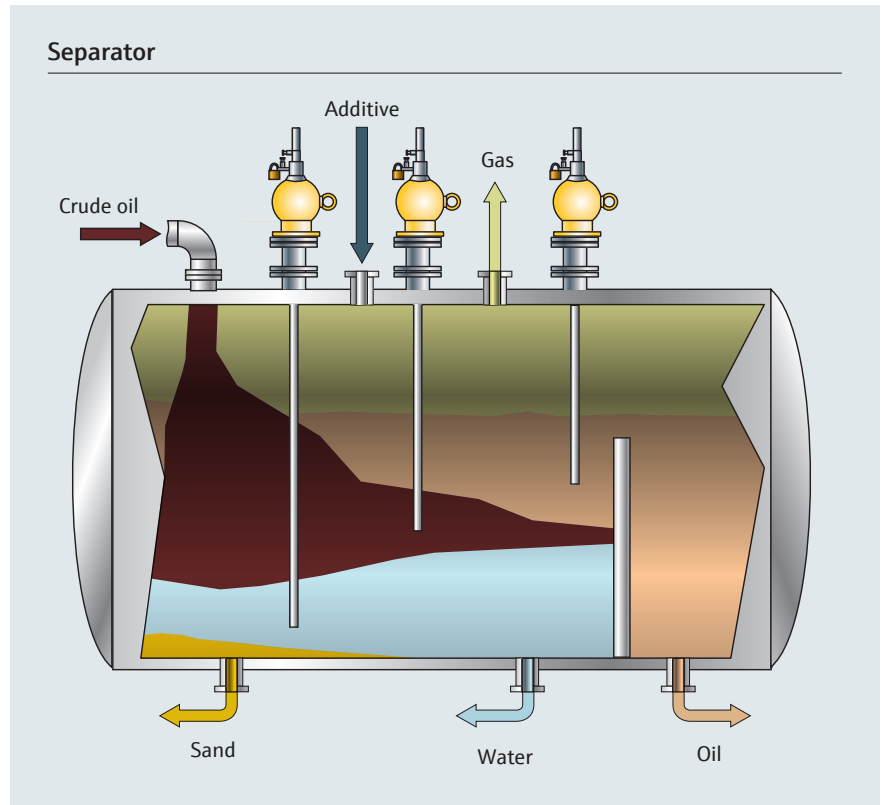

Arrangement of detectors for the profiler system on the tank.

✓ Advantages – Density Profile Measurement in separation processes

- Reduction of water and salt in the separating and refinery process
- Optimized use of chemicals due to an efficient separation process
- Online measurement improves quality control (or alternatively: Effective quality control of the production process)
- Level and density profile information in real time



Desalting

Crude oil is desalted at the refinery to prevent corrosion. In this process, water is added to generate an emulsion of crude oil and water. The emulsion is again separated in an electrostatic desalter in which the saline water sinks to the bottom and the desalted oil is pumped to the distillation process.

Since the desalter uses electrostatic plates, monitoring of the process is of paramount importance because an excessive level could endanger the mode of operation of the process equipment.

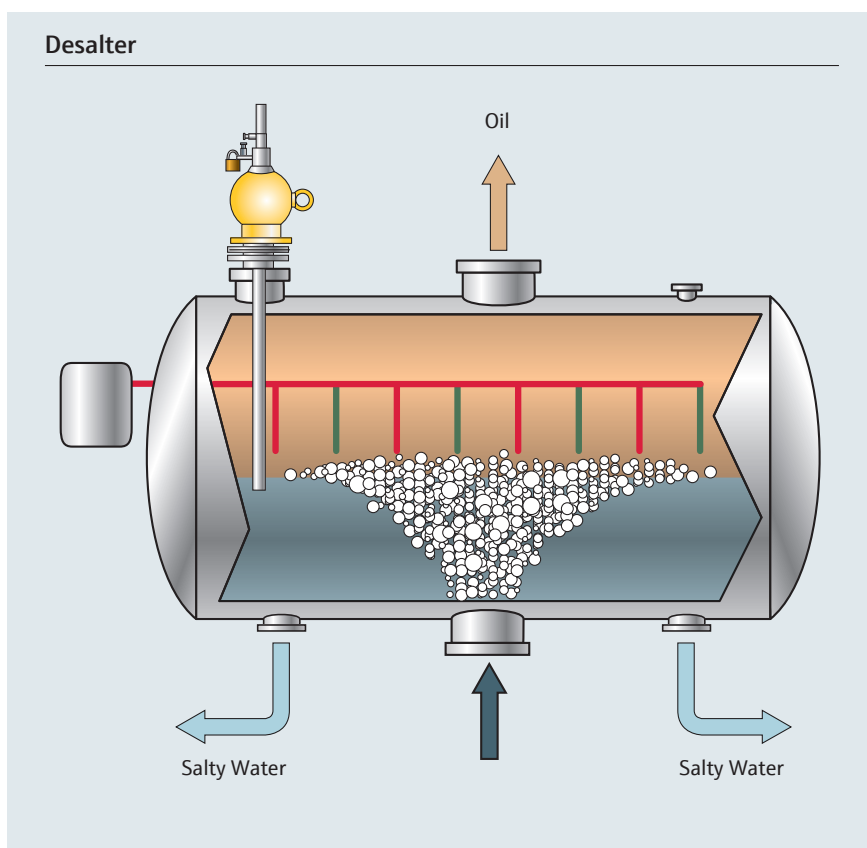

✓ Advantages – Density profile measurement in desalting processes

- Reliable reduction of salt in the process
- Reduction of plant downtimes and maintenance costs due to improved capacity utilization
- Salt build-up can be prevented in good time by exact measurements and process control
- Optimized use of chemicals due to an efficient desalting process

Economic efficiency of density profile measurements

Tank desanding In regular continuous operation, sand deposits have to be removed from a separation tank twice a month. During cleaning, the tank is not available for production thus reducing the output of the entire plant. In each maintenance interval, average costs of US\$ 24,000 are incurred which add up to more than US\$ 1 million during an operating period of 24 months.

DPS-optimized operation reduces the maintenance work so that tank cleaning is merely required once a month. The one-time acquisition costs of DPS are already amortized after approx. 6 months.

Additives Additives attain a faster separation of water and oil. DPS facilitates a more effective process which considerably reduces these additives. Our installations in oil production permit our customers savings of additives in the desalting process of US\$ 1000 per day on average.

The investment in one Profile Vision unit is thus already amortized after approx. 6 months.

Cost development tank desanding

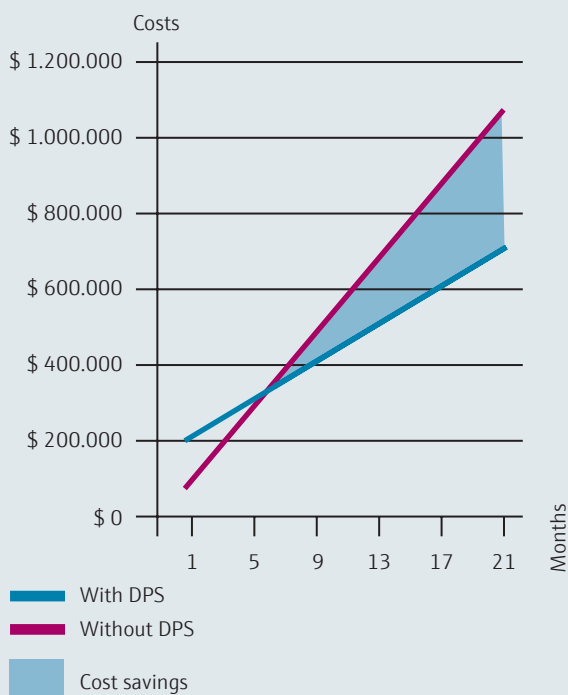

Cost development additives

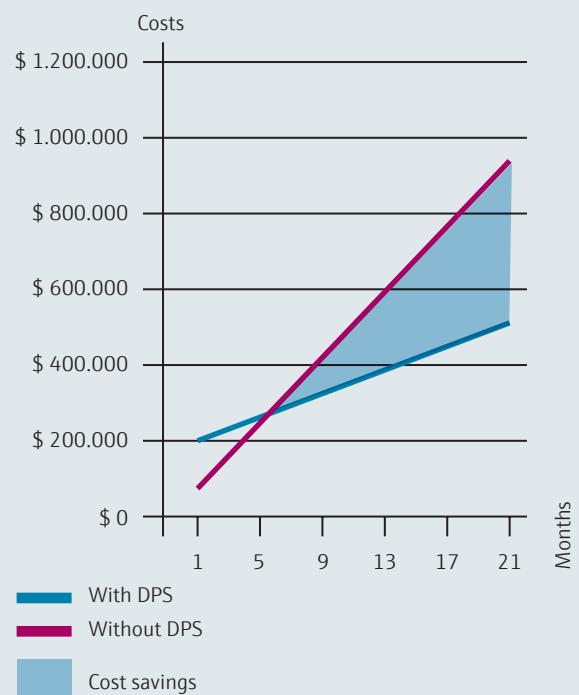

www.addresses.endress.com

CP01205F/00/EN/01.16