

Product Overview

A snapshot of Endress+Hauser's product lines

- Liquid Analysis
- Flow
- Level
- Pressure
- Temperature
- System Components
- Data Acquisition
- Services
- Solutions



Product Overview

A snapshot of Endress+Hauser's product lines

Be sure to visit our web site, www.us.endress.com, for the latest technical information on all products.

Contact Endress+Hauser at 888-ENDRESS for individual product Technical Information brochures.

Endress+Hauser, Inc.
2350 Endress Place
Greenwood, IN 46143

© 2013 Endress+Hauser

Endress+Hauser reserves the right to change or modify our product appearance and specifications at any time without notice. Though the information provided herein is believed to be accurate, be advised that the information contained herein is NOT a guarantee for satisfactory results.

05.13

Table of contents

Introduction to Endress+Hauser	3
Technologies overview	4 - 16
Endress+Hauser Product Overview	
Level	17
Vibration	
Capacitance	
Conductivity	
Radar	
Guided radar	
Microwave barrier	
Mechanical	
Ultrasonic	
Radiometric (gamma)	
Flow	30
Electromagnetic	
Coriolis	
Ultrasonic	
Vortex	
OEM	
Flow monitoring	
Differential pressure	
Pressure	43
Gauge/absolute	
Differential	
Hydrostatic	
Temperature	46
Transmitters	
Head transmitters	
RTD temperature sensors	
Thermocouples	
Data Acquisition and Components	50
Recorders	
Multi-functional components (display / power supply)	
Multi-functional components, DIN rail mounting	
WirelessHART	
Analysis	53
pH sensors / holders / transmitters	
Conductivity sensors / holders / transmitters	
Chlorine sensors / holders / transmitters	
Dissolved oxygen sensors / holders / transmitters	
Turbidity sensors / holders / transmitters	
Water/Wastewater analyzers	
Optical sensors and transmitters	
Services	77
Commissioning services	
FieldCare	
Field Xpert	
Plant life cycle (W@M)	
Applicator	
Technical support	
Repair	
Field Service	
Calibration services	
Calibration management	
Maintenance services	
Support services	
Process Training University	
Solutions	78
Tank and Terminal Management solutions	
Fluid Management solutions	
Field Network Engineering	
Inventory Management solutions	
Plant Asset Management	

Introduction to Endress+Hauser

Endress+Hauser is a global supplier of process automation solutions. The company develops, manufactures and sells sensors and systems for production and logistics in the process industry. These products acquire, transmit and use process information. The products are excellent in both performance and price; the services are ground-breaking. Both aid customers' competitiveness with a maximum of quality, safety and efficiency. The power of this global company is intensified by its local support to you. This support starts with excellent manufacturing facilities located within the US. ISO 9001 certified manufacturing facilities and ISO/IEC 17025 accredited calibration systems assure Endress+Hauser delivers highly reliable measuring instruments to customers throughout North and South America.

The company continues to expand its industry know-how, and ensures the competence of Sales and Service. A tight network of production and sales companies, together with representatives, gives Endress+Hauser a very strong presence across global markets.

The company owes its good reputation to employees' competence, creativity and commitment. Endress+Hauser behaves responsibly towards the community and environment, and is commercially successful. The financially strong and independent family company stands for continuity, the broadest range in its industry, and active relationships. Endress+Hauser seeks to be its customers' preferred partner throughout the world.

History

Endress+Hauser was founded by Georg H. Endress and Ludwig Hauser in 1953. It all began as a vision - the use of electronics for the remote measurement of level in containers, tanks and silos, on a reliable and accurate basis.

Endress+Hauser products are manufactured at state of the art Product Centers, using the newest manufacturing techniques available, and continuing to update equipment as technology changes. Each Product Center is responsible for a particular measuring technology; level products are designed and built by one Product Center, while flow measuring products are designed and built by another. This unique philosophy allows research and development to focus on a particular measurement technology. At the same time, the various technologies and best practices are shared among the Product Centers, giving rise to new ideas, designs, and products that are unsurpassed by any other measurement manufacturer.

Level measurement at Endress+Hauser has grown from single-point capacitance switches to continuous level measurement. Enhancing the various needs of industry, frequency shift tuning fork level switches from Endress+Hauser have become the standard for basic level switches. For aggressive materials, ultrasonic and radar measurement systems have been developed to meet all the level measurement requirements in industries where non-contact measuring is needed.

As our growth has continued in the field of level measurement, other fields have been added to achieve world-wide leadership. In 1977, Endress+Hauser met the need for more accurate and dependable liquid flow measuring by introducing a line of electromagnetic flow meters. As with our level instrumentation, the challenge for more accurate flowmeters and various types of in-line connections was met by Endress+Hauser. From the basic magnetic flowmeter to the microprocessor controlled systems of today, Endress+Hauser meets and exceeds the industry standards. As a company grows, so must its product base. Conductive fluids are just one medium of liquids flow. What about steam, gas, and non-conductive fluids? Once again, Endress+Hauser met the challenge by introducing a specialized vortex flowmeter. For industries that require mass flow and volumetric flow measurement, Endress+Hauser offers the Coriolis mass flow measuring system. This is the ultimate in mass flow technology, using straight through flow tubes, and a secondary containment vessel to ensure process safety.

Our commitment to further provide industry with a full line of measurement systems led our research and development engineers into the pressure field. Using our capacitance knowledge and ceramics, Endress+Hauser overcame the limitations inherent to conventional pressure sensors. We now produce ceramic, capacitive pressure measuring cells coupled with hybrid integrated circuits, capable of withstanding over-pressure loads up to 800 times rated pressure. Our sensors provide long-term stability in aggressive environments with various process connections to fit your industrial applications. Endress+Hauser offers systems to measure processes from vacuum to 10,500 psig, differential pressure systems, and hydrostatic pressure systems.

Industrial requirements continue to rise, and so does the need for accurate recording instruments. Endress+Hauser not only provides traditional recorders for which there is still a need, but also recording devices that plot continuous colored traces, print data, record process events, and notify alarm status. Our commitment to perfection allows all that information to be provided simultaneously in stand-alone monitoring units or integrated into your process control system.

Endress+Hauser is committed to the industries we serve. We develop, manufacture and sell sensors, transmitters and systems, which extract information from manufacturing procedures in the processing industry and prepare it for use by process control systems. The physical variables include level, pressure, flow, analytical and temperature, as well as industrial components. Our goal is to continue our commitment to new products and services for our valued customers.

A network of skilled sales and service personnel are located worldwide, ready to provide the customer support required. Local sales and service locations assure there is someone available, in your time zone, to support you with knowledgeable technicians, spare parts inventory and calibration facilities.

Level

Level measurement and control can be found in almost all types of industries; from the food and pharmaceutical industries where hygiene is of paramount importance, to the chemical, oil, gas and petrochemical industries which require robust and reliable instrumentation to suit the hazardous conditions.

Endress+Hauser offers a complete range of sensors and transmitters for virtually all aspects of level measurement. Our experience in all areas of process measurement has led to the development of a product offering that can withstand the most challenging process conditions. Their reliability can be counted on in corrosive and abrasive environments, sanitary applications and general process industries.

Level products

Stable level measurement, a lower total cost of ownership, reduction of inventory loss at the measuring point - areas that you the customer look for in order to lower production cost and provide the highest quality product. Endress+Hauser's dedication to research and development coupled with leading edge technology ensures each instrument manufactured meets the needs of our customers' applications.

By employing specific measurement technologies, Endress+Hauser level products provide measurement solutions in:

- **Vibration:** Level limit switch for use in liquids or solids, using a tuning fork or rod. A piezoelectric drive vibrates the assembly to its resonant frequency which changes state when material is present.
- **Mechanical:** Economical paddle limit switch for applications in dust hazardous areas. Ideal for high or low level indication in powders, granulates, animal feed, cement, etc. When material comes in contact with the paddle, rotation is stopped and a switch point takes place.
- **Capacitance:** Point level or continuous level in liquids or solids for non-conductive materials, based on the dielectric constant of the material.
- **Conductivity:** Level limit switch for multiple point detection in conductive liquids using single or multiple (up to 5) rods or cables.
- **Radar:** Radar level measurement is designed for challenging applications requiring non-contact, continuous measurement. Radar level instruments are ideal for dynamic process applications with rapid level changes or agitator blades involving liquids and slurries. Endress+Hauser uses the pulse time-of-flight principle, where short pulses are emitted towards the material from an antenna. Our newest radar instrument, Levelflex, launches an electrical impulse down a cable or probe to the material surface.
- **Ultrasonics:** Ultrasonic continuous level measurement involves no contact with the measured material, making it ideal for applications in hostile environments. Ultrasonic measurement is versatile and commonly used for continuous non-contact measurement of liquids, slurries and solids. A tank with an ultrasonic system can be emptied and then filled with a different material and the level reading will still be accurate.
- **Radiometric:** Level measurement using gamma radiation for difficult applications, such as high temperatures, high pressures, corrosive materials, toxic chemicals, etc. where non-contact measurement is required. Radiometric measurement from Endress+Hauser provides level limit detection, continuous level, interface measurement and density or concentration.
- **Hydrostatic/differential pressure:** (refer to Pressure)

Basic Level Measurement Technologies

Vibration (liquids) Point level detection using a vibrating fork or. When activated by a bimorph piezoelectric drive electronics, the forks vibrate at their resonant frequency. When material covers the forks, the frequency changes. This change in frequency is monitored, and at an appropriate change in frequency, the switching logic is activated. This technology is used in liquids, slurries, and oils for high level or low level limit control and pump control.

Changes in the amplitude of the tuning fork vibrations are not measured and can be ignored. This provides protection against buildup, gas bubbles and turbulence. Materials with varying density, viscosity, foam, suspended particles and composition changes do not affect the switch point of the tuning fork.

Vibration (solids) The vibrating rod point level switch is used in bulk solids such as animal feed, rice, dye powders, cement, and is available for use in dust incensive hazardous areas.

A piezoelectric drive excites the vibrating rod, the rod's vibrating amplitude changes (the vibration is damped). The electronics compare the actual amplitude with a target value and indicate whether the rod is vibrating freely or covered with the process material.

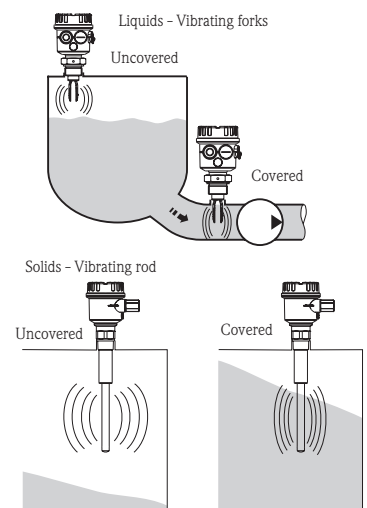

Mechanical A reduction gear and synchronous motor drive the shaft and paddle. If the paddle is stopped by material covering it, the hinged motor moves from the rest position to the switch position. This movement operates two switch contacts - the first is for external level indication and the second switches the power off to the motor. When the material falls away from the paddle, the hinged motor returns to its rest position, the two contacts switch to normal operation, and the paddle starts to rotate. Intermittent loads that operate against or even in the same direction of rotation are evened out by using a slip clutch.

Capacitance Capacitance level measurement systems take advantage of the dielectric constant in all materials to determine changes in level.

A capacitor is no more than a pair of conductive electrodes, or plates, with fixed spacing and a dielectric (process material) between them. In the most common applications, the probe element (a metal rod or cable) serves as the active plate, while the process vessel serves as a ground plate. When “empty space” or air in the vessel is replaced by the process material, the capacitance electronics register the change in capacitance. This change is converted to an electrical signal and used to provide an output from a point or continuous level. Level switches and continuous level measurements can be accomplished with the right probe configuration and electronics.

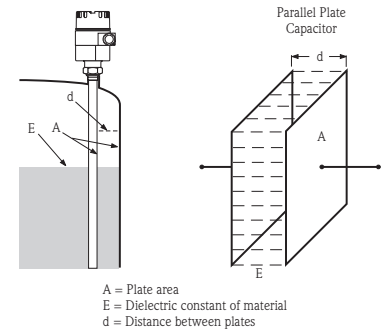

Conductivity An alternating voltage exists between the rod probes in an empty tank. As soon as the conductive liquid in a tank creates a connection between the ground probe rod and, for example, the maximum probe rod, a measurable current flows and the instrument switches. With level limit detection, the instrument switches back as soon as the liquid clears the maximum probe. With two-point control, the Liquipoint does not switch back until the maximum and minimum probe is cleared.

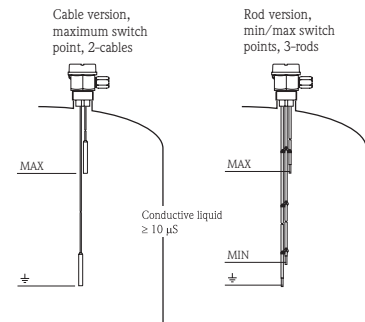

Using alternating voltage prevents corrosion of the probe rods and electrolytic destruction of the product. The material used for the tank walls is not important for measurement because the system is designed as a closed potential-free circuit between the probes and the electronics. There is absolutely no danger from electrical shock if the probes are touched during operation.

Radar, free-space for liquids and solids Endress+Hauser uses the pulse time-of-flight (TOF) principle, where short radar pulses are emitted towards the material from an antenna. These pulses are reflected from the material surface and detected by the same antenna, now acting as the receiver. The distance to the material surface is proportional to the run time of the radar pulse, which is converted into a level signal.

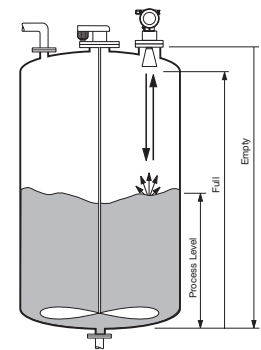

Radar systems from Endress+Hauser are suitable in areas of high temperature or pressure, in the presence of gas vapors, vacuum, turbulence, or dust.

Guided radar The newest radar instrument from Endress+Hauser, Levelflex, is a “downward-looking” time-of-flight system, which measures the distance from the probe mounting (top of the tank) to the material level. An electrical impulse is launched and guided down the probe or cable, which acts as a surface wave transmission line. When the surface wave meets a discontinuity in the surrounding medium (a sudden change in dielectric constant), it is partially reflected. The reflected impulse travels back up the cable to the pulse sampler where it is detected and timed.

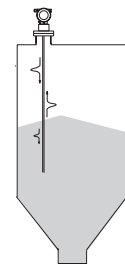

Radar systems from Endress+Hauser operate in a frequency band assigned for industrial, scientific and medical applications. Its low beam power allows safe installation in metallic and nonmetallic vessels, with no risk to humans or the environment. This technology does not require an FCC site license and can be used without restrictions.

Ultrasonic level measurement In ultrasonic level measurement the operating principle is based on the measurement of the travel time of a sound signal transmitted from and received by the same sensor after reflection from the liquid or solids surface. The travel time of a sound pulse is a direct measure of the height of the material in a silo or tank. The distance in air traveled by the pulse in feet is equal to the travel time in seconds multiplied by the speed of sound in feet per second. Signal process techniques, including temperature compensation and rejection of false echoes returned by tank obstructions, are used to maintain the integrity of the level information.

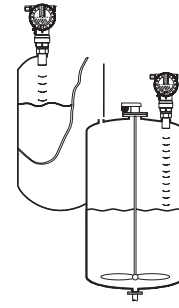

Ultrasonic systems will not work in vacuums or gasses other than air.

Gamma In gamma measurement, a radiation source (^{137}Cs or ^{60}Co) is emitted in one direction through the process vessel or pipe and received by the transmitter. The radiation source is enclosed in a shielded container which allows the radiation to be emitted in only one direction and shields the radiation in any other direction. The Gammapiilot M transmitter contains a scintillator, a photomultiplier and the evaluation circuit. Gamma radiation generates light flashes within the scintillator. The photomultiplier converts these flashes into electrical pulses and amplifies them. The pulse rate is a measure of the radiation intensity. Depending on the calibration, the pulse rate is converted to a level, limit, density or concentration signal by the evaluation circuit.

- 1 Point level measurement
- 2 Continuous level measurement
- 3 Interface measurement
- 4 Density or concentration measurement

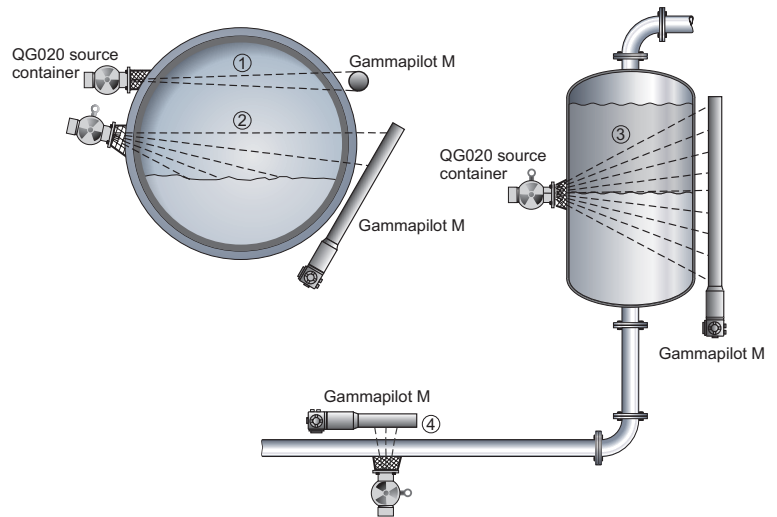

Flow measurement and control can be found in almost all types of industries; from the food and pharmaceutical industries where hygiene is of paramount importance, to the chemical, oil, gas and petrochemical industries which require robust and reliable instrumentation to suit the hazardous conditions.

Endress+Hauser offers a complete range of sensors and transmitters for virtually all aspects of flow measurement. Our experience in all areas of process measurement has led to the development of a product offering that can withstand the most challenging process conditions. Their reliability can be counted on in corrosive and abrasive environments, sanitary applications and general process industries.

Flow products Stable flow measurement, a lower total cost of ownership, reduction of pressure loss at the measuring point - areas that you the customer look for in order to lower production cost and provide the highest quality product. Endress+Hauser's dedication to research and development coupled with leading edge technology ensures each instrument manufactured meets the needs of our customers' applications.

By employing specific measurement technologies, Endress+Hauser flow products provide measurement solutions in:

- **Electromagnetic:** Proline Promag electromagnetic flowmeter versions are designed to meet the requirements of various industries, ranging from sanitary requirements meeting 3-A and EHEDG standards, as well as for use in hazardous areas. Promag sensors are available in sizes from 1/2" to 78", and are suited for water, wastewater, chemical, food, beverage, pharmaceutical and process applications.
- **Coriolis:** Proline Promass Coriolis flowmeters are designed to measure mass flow, volume flow, density, and temperature. The single full-bore Promass I sensor is capable of integral viscosity measurement. Promass sensors are available in sizes from 1/24" up to 10" with dual straight tubes, dual bent tubes, and single straight tube designs plus rigid secondary containment providing a second line of defense and increased process safety. Promass systems meet the requirements of various industries, ranging from 3-A sanitary requirements and EHEDG standards, SIL 2 requirements, and use in hazardous areas. A high temperature sensor (Promass F, up to 660°F) is available for special applications.
- **Ultrasonic:** Proline Prosonic ultrasonic flowmeters are designed for non-contact flow measurement in difficult applications such as glass reinforced pipe, ductile iron pipe with cement lining or steel pipes with plastic liners. Prosonic flow sensors are available for nominal pipe sizes from 1/2" up to 160". Clamp-on sensors are constructed of stainless steel and rated NEMA 6P and can be completely submerged. Insertion sensors are also available, which once installed, can be replaced without interrupting the process. Prosonic systems are designed for use in water, wastewater, chemical and process industries.
- **Thermal:** Proline t-mass thermal mass flow measuring systems are designed for direct mass flow measurement of gases. Two types of sensors are available: in-line flanged for pipes sizes from 1/2" to 4", or insertion sensors for pipe sizes from 3" to 60". Insertion version can be programmed for circular or rectangular ducting installation. On-board software allows the selection of up to 20 pure gases and the creation of mixed gases with a maximum of 8 components (e.g. Biogas)
- **Vortex:** Proline Prowirl vortex flowmeters provide accurate and reliable measurement of flow and temperature for computing mass flow and heat consumption. Ideal for gas, steam and liquids with a process temperature range of -330°F to +750°F. With constant pressure, the Prowirl can output the mass flow of superheated steam or the mass and volume flow of other gases. The Prowirl sensor is designed for wafer mounting (1/2" to 6") or ANSI flanged (1/2" to 12") and is ideal for chemical, petrochemical, power and district heating industries and other process applications.
- **Differential Pressure:** Differential pressure flow measurement is based on two well-known technologies; orifice plate and pitot tubes. A primary element (orifice plate or pitot tube) creates a pressure difference inside the pipe, which is a direct measure of volume or mass flow. Differential pressure measurement is ideal for gas, steam and liquids in applications with temperatures from -328 to +1830°F in pressures up to 6300 psi. Orifice plate systems range in size from 3/8" to 40"; pitot tube systems are ideal in sizes from 1-1/2" up to 472".



Proline Proline stands for a common software electronics structure, an identical operating concept, common servicing concept and even field validation. The Proline transmitter electronics are available in two versions: a basic version for most standard operations (Proline 50/80/90/91 transmitters, and a highly sophisticated version (Proline 53/55/83/93 transmitters) with extensive functionality and additional software options like Advanced Diagnostics. Each PROline flowmeter is configured in the same manner: quickly and easily guided by simple prompts on the display. Critical data is stored on removable chips allowing for easy exchange of electronics.

Basic Flow Measurement Technologies

Electromagnetic flow measurement Electromagnetic flow meters measure the volume flow rate of electrically conductive fluids. The measuring sensor consists of a lined pipe, an electromagnetic coil, and corrosion-resistant electrodes (not to all process materials). When the conductive liquid or slurry passes through the magnetic field (produced by the magmeter electronics), it generates a voltage proportional to the average velocity of the material. It is based on Faraday's law of induction: if a conductor moves within a magnetic field, a voltage will be induced therein. Liquid media can be accurately measured with conductivities of 5 $\mu\text{S}/\text{cm}$ and above.

The voltage induced by the flowing fluid is proportional to the flow rate. The measuring electrodes detect the voltage signal which is sent to an amplifier where it is digitized and communicated to the transmitter. The transmitter processes the signals and outputs current and pulse signals which are used for totalizing, pump control, limit values, batch functions, etc.

Coriolis mass flow measurement The measuring principle is based on the controlled generation of Coriolis forces. The sensing meter contains a flow tube(s), which in the absence of flow, the inlet and outlet sections vibrate in phase with each other. When liquid is flowing, inertial (Coriolis) forces cause a phase shift between inlet and outlet sections. Two sensors measure the phase difference, which is directly proportional to flow.

The amplitude of the Coriolis force depends on the moving mass (process material), its velocity in the system, and therefore its mass flow. The flowing material causes the tube(s) to oscillate, acting like a tuning fork. As the mass flow increases, the phase difference also increases. The oscillations of the measuring pipe(s) are determined using electro-dynamic sensors at the inlet and outlet of the measuring tube assembly. The measurement principle operates independent of temperature, pressure, viscosity, conductivity or flow profile.

The Promass I has a full bore, straight-through, single-tube design which operates somewhat differently than the dual-tube design. In order to maintain balance for flawless measurement, a patented Torsion Mode Balanced (TMB) system is used. By exciting an eccentrically located, counter-oscillating pendulum mass, the single tube system provides accurate measurement, even with changing process and ambient conditions.

The Promass measuring system is used wherever mass flow measurement is critical in mixing and batching of raw materials, process control, measurement of quickly changing densities and control of product quality. Coriolis meters can measure mass flow, volumetric flow, density, temperature, and/or viscosity.

Vortex shedding flow measurement The vortex sensor measures flow rate using the Karman Vortex Street principle. As fluid flows past a bluff body, vortices are produced on alternate sides of the body. The frequency at which these vortices are produced (or shed) is directly proportional to the flow rate and is independent of fluid density, viscosity, pressure, or temperature.

The principle function of the flow meter is threefold: the bluff body disrupts the fluid stream creating vortices, the DSC sensor and front-end electronics detect the shedding vortices and process a pulse signal output signal, the electronics convert the signal to a usable scaled output signal. The DSC (Differential Switched Capacitor) sensor improves the signal-to-noise ratio and eliminates the effects of vibration on the measuring signal.

Vortex pulses acting on the tongue (DSC sensor) mistune the capacitors and this change is detected by the capacitor circuit. The elastic behavior of the carrier rod and tongue are matched by computer design which effectively cancels any pipe vibration acting on the sensor. The carrier rod and tongue move in absolute synchronism regardless of the vibration axis, including rotational vibration. By eliminating any external effects of vibration, only the vortex pulse signals are processed by the electronics.

The Prowirl vortex measuring system is ideal for liquids, gases, and steam. Applications for oxygen, nitrogen, cryogenics, and solvents are well within the measuring techniques of the vortex system.

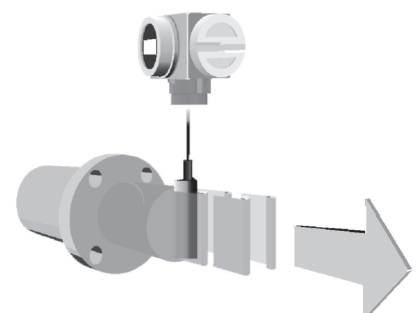
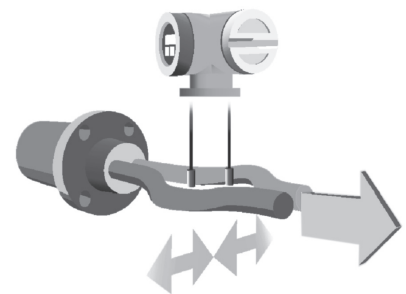
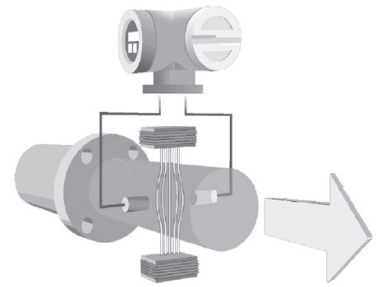

Ultrasonic flow measurement The ultrasonic flow system is a non-intrusive, externally mounted measuring system which uses ultrasonic sound waves to measure the flowing fluid in a pipeline. The Prosonic flow systems operates on the principle of transit time difference. An acoustic signal (ultrasonic) is transmitted from one sensor to another. The time (transit) that the signal requires to arrive at the receiver is then measured. According to physical principles, the signal sent against the direction of flow requires longer to return than the signal in the direction of flow; therefore, the difference in the transit time is directly proportional to the velocity of flow. The transmitter converts the measured values supplied by the sensors into standardized output signals.

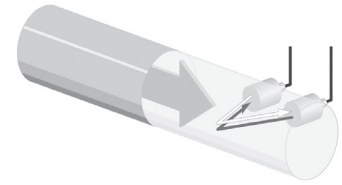

The Prosonic flow sensors (clamp on versions) are mounted directly onto existing piping. Isolating or opening the piping is not required. The system is ideal for bidirectional measurement of pure or slightly dirty liquids. The Prosonic flow system is especially suitable when retrofitting equipment as no interruption of the process is necessary. Endress+Hauser does offer insertion type sensors. Once installed, the sensors can be replaced without interrupting the process.

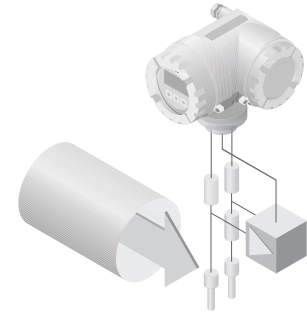

Thermal mass flow measurement The thermal mass flow measuring system is based on a thermal dispersion principle. The thermal principle operates by monitoring the cooling effect of a gas stream as it passes over a heated transducer (PT 100). Gas flowing through the sensing section passes over two PT 100 RTD transducers, one of which is used conventionally as a temperature sensing device, while the other is used as a heater. The temperature sensor monitors the actual process values while the heater is maintained at a constant differential temperature above the actual process temperature by varying the power consumed by the sensor. The greater the mass flow, the greater the cooling effect and power required to maintain the differential temperature. The measured heater power is therefore a measure of the gas mass flowrate.

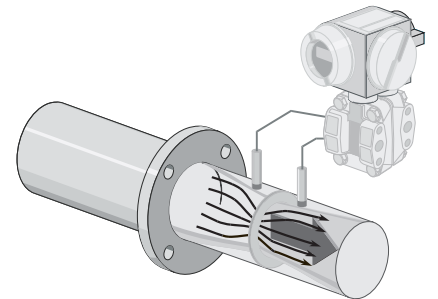

Differential pressure flow measurement Differential pressure flow measurement is based on two well-known technologies; orifice plate and pitot tubes. A primary element (orifice plate or pitot tube) creates a pressure difference inside the pipe, which is a direct measure of volume or mass flow. Two impulse lines carry the differential pressure to the transmitter, where it is converted into the corresponding output signals.

Orifice plates have a circular constriction in the pipe cross-section to create the difference in pressure. Static pressure drops in relation to the associated increase in flow velocity. The difference in pressure upstream and downstream to the orifice is a measure of the flow rate.

Pitot tubes have various pressure-tapping holes to measure total head pressure at the leading end and static pressure only at the trailing end. The corresponding pressure difference is proportional to the flow rate.

Metering in hot-water and cooling systems and metering steam and condensate at very high temperatures in secondary systems remain primary areas of application even today. Pitot tubes are a viable alternative to orifice plates where low pressure losses are required and when flow has to be measured in large diameter pipes (up to several feet). The transmitters in differential-pressure systems can be replaced at any time without the process having to be interrupted.

Pressure

Pressure measurement and control can be found in almost all types of industries; from the food and pharmaceutical industries where hygiene is of paramount importance, to the chemical, oil, gas and petrochemical industries which require robust and reliable instrumentation to suit the hazardous conditions.

Endress+Hauser offers a complete range of sensors and transmitters for virtually all aspects of pressure measurement. Our experience in all areas of process measurement has led to the development of a product offering that can withstand the most challenging process conditions. Their reliability can be counted on in corrosive and abrasive environments, sanitary applications, and even in areas where excessive temperature occurrences threaten operations.

Pressure products Pressure sensors guarantee safety and provide crucial information on the process. Even in level and flow measurement, pressure and differential pressure measuring technology is often used. This makes pressure one of the most important measured variables in process automation, inspiring Endress+Hauser to continuously improve and drive forward the development and production of high-quality pressure measurement. With its extensive portfolio of pressure measuring instruments, Endress+Hauser can offer a pressure transmitter that combines the latest technology with high-grade material for every application and budget.

By employing specific measurement technologies, Endress+Hauser pressure products provide measurement solutions in:

- Gauge pressure
- Absolute pressure
- Differential pressure
- Hydrostatic pressure (level)
- Flow (Differential pressure with Orifice Plate or Pitot Tube)

Pressure Basic Measurement Technologies

Gauge/Absolute pressure measurement Pressure measurement for gauge, absolute, vacuum and compound are based on two technologies; capacitance ceramic sensors (for up to 600 psig) and silicon metallic sensors (for up to 10,500 psig).

Ceramic - The operating principle of the ceramic sensor is based on capacitance technology. As pressure is applied to the ceramic diaphragm, the measuring capacitor deflects by a minimum of less than 0.001 inch. A change in capacitance proportional to pressure is measured between the substrate electrode and the measuring (diaphragm) electrode. The electronics convert this differential capacitance into a usable output signal. The actual measuring range is determined by the thickness of the ceramic diaphragm which, with overload, stops on the substrate without sustaining damage.

Silicon - The silicon sensor incorporates insulated thin film strain gauges. The line pressure deflects the separating diaphragm and the filling fluid transmits the pressure to a resistance bridge. The bridge output voltage, which is proportional to pressure, is then measured and processed.

The silicon sensor offers a wide temperature range, a small and easily compensated temperature coefficient and long-term stability. Its good elasticity properties ensure high reproducibility, low hysteresis and fourfold resistance to overload.

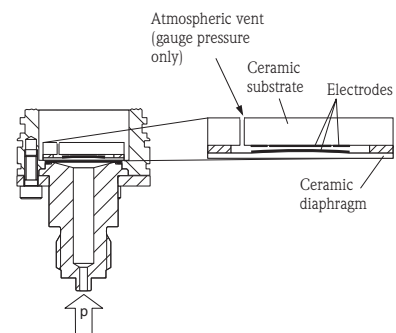

Ceramic measuring cell

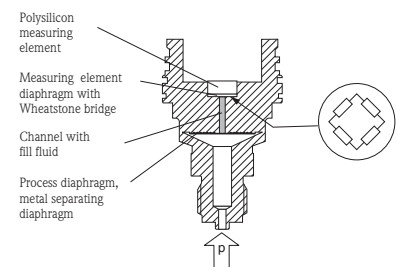

Silicon measuring cell

Differential pressure measurement Differential pressure sensors are available in two versions; single chamber ceramic (for up to 1200 inH₂O) or silicon sensors (for up to 580 psi).

Ceramic - The ceramic sensor consists of a substrate and two diaphragms. The diaphragms and substrate constitute two measuring surfaces and are connected by a capillary. Silicone oil, mineral oil or inert oil serves as the filling fluid in the capillary. A differential pressure-proportional change in the capacitance is measured by the electrodes on the ceramic substrate and diaphragms.

Silicon - The silicon measuring sensor is comprised of a silicon diaphragm which has pressure sensitive thin-film resistors. The differential pressure acting at the isolating diaphragms is transmitted to the measuring element by silicone oil or inert oil. The silicon diaphragm deflects accordingly causing a change in resistance which is measured and processed by the transmitter electronics.

The silicon sensor offers a wide temperature range, a small and easily compensated temperature coefficient and long-term stability. Its good elasticity properties ensure high reproducibility, low hysteresis and fourfold resistance to overload.

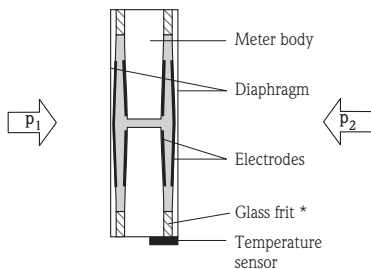
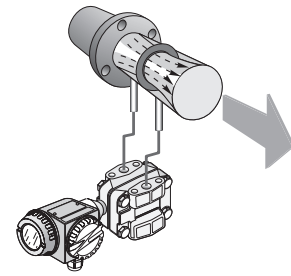

* Glass frit fixes the diaphragm onto the meter body

Ceramic measuring cell

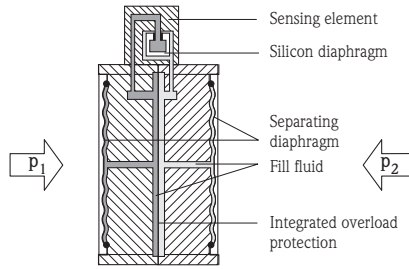

Silicon measuring cell (4 inH₂O and 12 inH₂O)

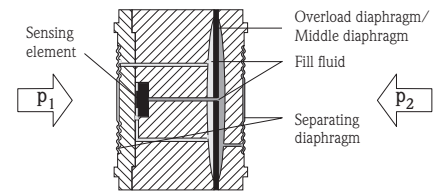

Silicon measuring cell (40 inH₂O and above)

Hydrostatic pressure measurement Hydrostatic level measurement provides both continuous and limit control of liquids and pastes. Together with an appropriate transmitter, they can be used to determine level, volume, differential pressure, product weight, density and can be integrated into various automation systems.

The weight of a column of liquid generates a hydrostatic pressure. At constant density, the hydrostatic pressure is a function of the height of the liquid only. The atmospheric pressure acts on the measuring cell through a pressure compensation system and thus is self-compensating. An overload substrate protects the measuring cell from pressure peaks to 20 times the nominal rating (maximum 360 psig). This ensures that accuracy remains unaffected. The measuring cells cover a pressure range from 15 inH₂O to 58 psig. Vacuum can be measured to 1.7 psia.

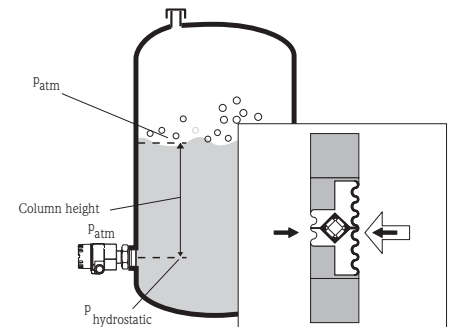

Temperature

Temperature measurement and control can be found in almost all types of industries; from the food and pharmaceutical industries where hygiene is of paramount importance, to the chemical, oil, gas and petrochemical industries which require robust and reliable instrumentation to suit the hazardous conditions.

Endress+Hauser offers a complete range of sensors and transmitters for virtually all aspects of temperature measurement. Our experience in all areas of process measurement has led to the development of a product offering that can withstand the most challenging process conditions. Their reliability can be counted on in corrosive and abrasive environments, sanitary applications, and even in areas where overpressure or excessive temperature occurrences threaten operations.

Temperature products Endress+Hauser provides a wide range of temperature products, including transmitters and sensors designed to meet the requirements of all industries.

Temperature transmitter family iTEMP® transmitters are an installation-ready solution to improve the functionality of temperature measurement by increasing accuracy and reliability when compared to direct wired sensors. Overall installation costs are lower than with direct wired sensors, since inexpensive two-conductor 4 to 20 mA signal wire can run over long distances – instead of expensive extension or compensation wires for thermocouples.

Each unit can be configured for a variety of sensor inputs: RTD, thermocouple, millivolt or ohm. All iTEMP® transmitters provide long term stability $\leq 0.05\%$ per year. Transmitter types available from Endress+Hauser include:

- Field transmitters
- DIN rail mounted transmitters
- Head transmitters

Temperature sensors Class A Pt100 thermometers are exclusively used in Endress+Hauser sensors. The mechanical variations of sensors, thermowells and housings ensure the highest functionality, even under harsh environmental conditions. Certified and automated welding technologies and the computer controlled calculation and sizing of thermowells to international standards safeguard the practicality of the products. Sensor technologies available include:

- Thermocouple
- RTD

Temperature Basic Measurement Technologies

Of all process variables, temperature is the one with which people have the most personal familiarity. Yet, many of the measurement issues are not clearly understood by the average person. Further, the concepts of temperature and heat are often confused.

Fundamentally, temperature is indicative of the average amount of kinetic energy in a group of molecules. That is, it is a direct indication of the average amount of molecular motion in the studied object. Even the human senses detect temperature changes, and can sense which of two objects has the higher temperature. Yet temperature is not a measure of the amount of heat (or heat energy) contained within an object. An iceberg, although colder than a lit match, contains vastly more heat than a lit match. Heat may be thought of as the sum of all the kinetic energy of all the molecules-in-question. If temperature tells us nothing about the energy contained in an object, what then does temperature tell us?

Our concepts of “colder” and “warmer” are directly related to relative temperatures, and temperature tells us which way heat will flow. When two bodies are in contact, heat (or energy), always moves from a body of higher temperature to a body of lower temperature (except in the case of a “heat pump”). Two simple bodies in contact and left alone, will eventually reach the same temperature.

The expression of a measured value may be in any one of several “temperature scales”, which are describe in units by degrees. The specific unit used is indicated by the “type” of degree stated. All temperature scales seek to create a one-to-one correspondence between the indicated temperature value and a specific level of molecular activity. The most commonly used scales are Celsius (formerly Centigrade) and Fahrenheit. These linear scales have somewhat arbitrary “starting points” for what they consider to be “zero degrees”. In contrast the Kelvin and Rankine scales set zero degrees to correspond to the theoretical “absolute zero” where all molecular motion would cease. These latter scales are a bit more convenient when the goal is to relate a temperature measurement directly to heat content or kinetic energy, since the temperature is directly proportional to both, and requires no offset to the more arbitrary zero points of Celsius and Fahrenheit scales.

What is it, fundamentally, that causes a temperature sensing device (or even your skin) to get a reading of the temperature? At the molecular level, it is the result of the aggregate momentum transferred to the sensing device by all the collisions of moving molecules.

In industrial processes, the measurement of temperature is not only critical for numerous reasons, but it is also the single most common process variable measured.

Although there are several sensor types used to transducer sensed temperature into a measurable and usable electrical signal, the vast majority used are one of two types - the "RTD" (Resistive Temperature Device) or TC (Thermocouple).

Resistive temperature devices capitalize on the fact that the electrical resistance of a material changes as its temperature changes. As their name indicates, RTDs rely on resistance changes in a metal, with the resistance rising more or less linearly with temperature.

When two wires composed of dissimilar metals are joined at both ends and one of the ends is heated, there is a continuous current which flows in the thermoelectric circuit.

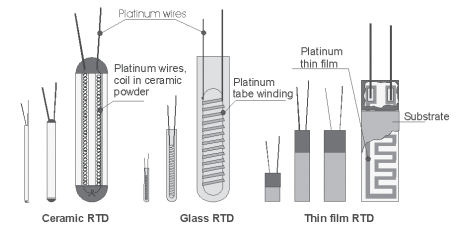

RTD types

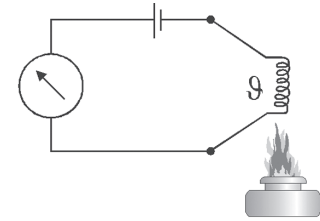

Resistive temperature measurement

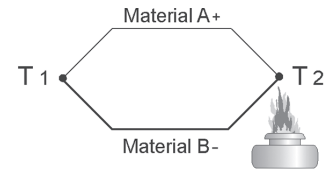

Thermocouple temperature measurement

Data acquisition and system components

Our recorders and components are designed for simple installation and are user friendly. We also pride ourselves on protecting both resources and environment. Easy to read graphic displays combined with power failure secure storage and manipulation monitored measured data archiving guarantees safe traceability of process sequences in all industrial areas. We develop sensors, transmitters and systems that reliably record, transmit and process critical plant information to optimize your process control.

Endress+Hauser offers recorders from simple data collection and display to multi-channel, multi-instrument monitoring and process control. System components are necessary in order ensure that measurements such as energy supply and sensor monitoring comply with international industrial standards and regulations. Our range of system components not only cover these basic requirements, but also increase plant availability via integrated diagnostic functions. They also optimize process by direct front-end control or manage energy usage with tested calculation methods.

The range of system components offered:

- Process displays for both field and panel mounting
- Active barriers and power supplies
- Process transmitters
- Energy managers
- Surge arresters

Analysis

Water, the most abundant substance on earth is used throughout the industrial world as a critical substance in the manufacturing processes. From the Chemical, Oil, and Gas Industries to the Automotive industry, within the Pulp and Paper Industry to the precise manufacturing environment of a Semiconductor plant, water is there, providing the medium in which many products are made, modified, and/or cleaned.

The purity of our drinking water has increasingly become a matter of public concern. Most drinking water supplies today require special treatment before it can be distributed and utilized. This is to eliminate possible toxic and infectious contaminants and make it safer for human consumption.

Endress+Hauser offers a full line of analytical systems important to different interests and industries. Examples of available technologies and industries include:

pH	Environmental
Oxidation/Reduction (ORP)	Corrosion
Conductivity	Scaling
Chlorine	Disinfecting
Dissolved Oxygen	Power, feed water
Turbidity	Dissolved solids
Optical	Fermentation, emulsions, effluent
Chemical Analysis	Water/Wastewater

Analytical products By employing specific measurement technologies, Endress+Hauser analytical products provide measurement solutions in:

- **pH:** pH is the measurement of hydrogen ion activity. It is measured on a scale of 0 to 14, where zero is extremely acid and 14 is extremely alkaline. The mid point of 7.0 pH is distilled water. It is the most widely used liquid analysis measurement, and is found in all industries. Used to determine the degree of acidity or alkalinity of a sample, pH measurement is a number that is directly related to a ratio of H^+ (hydrogen ion) and OH^- (hydroxyl ion) concentrations in a solution.

Endress +Hauser offers two groups of pH electrodes. CPF compact electrodes (non-glass) which are inserted directly into the process, or CPS glass electrodes which are placed in a separate holder.

pH glass electrodes: The method of pH measurement using glass electrodes is a potentiometric measurement method. Since glass is basically an electric insulator, amplifiers for the pH measurement must have an extremely high input impedance. The measuring effect is based on a pH-sensitive glass membrane, whose surface reacts to the acid content of the solution with a specific voltage.

This voltage is then measured relative to a reference element. Most modern pH glass electrodes display high selectivity (low cross-sensitivity to ions other than H^+) over a wide temperature range. A pH sensor achieves the outstanding performance of linear measurement of a material component over a concentration range of 14 (!) exponents.

pH non-glass electrodes: Apart from using a glass membrane, the pH value can also be measured using an ion-selective field-effect transistor (ISFET). It is, in effect, a simple transistor with a source and drain that are separated from the gate by means of an isolator. As with the glass membrane, hydrogen ions from the medium can accumulate on the gate. The resulting positive charge on the outer side of the gate is “mirrored” on the inner side where a negative charge occurs. This makes the semiconductor channel conductive. The “field effect” results from the extent of the conductivity: the higher the pH value of the liquid, the more H^+ ions accumulate on the gate and the more current can measurably flow between the source and drain. In contrast to the glass electrode, there is no ion flow between the fluid and the sensor. “Chemistry” and electrical measurement are kept totally separate. As a result, the sensor material does not change and the need for re-calibration is by no means as frequent as with glass electrodes. Since there is no source layer, ISFETs are also suitable for pH measurement in media with a low proportion of water. Modern ISFET materials are highly selective and follow the Nernst law in closer tolerance limits than glass. The sensor’s extreme robustness comes from embedding the chip in a stable and unbreakable PEEK body.

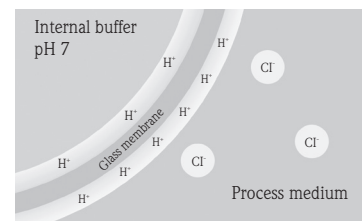

Voltage occurrence with pH measurement with glass electrodes

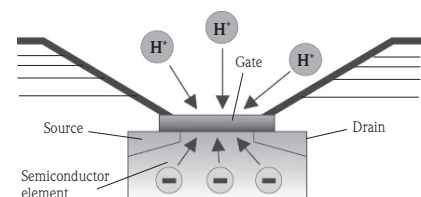

The current between the source and drain of the semiconductor element depends on the charge at the gate and thus directly on the pH value.

- **ORP:** ORP (Oxidation-reduction Potential) measurements are used to monitor chemical reactions, quantify electron activity or determine the oxidizing or reducing properties of solutions ORP is related to pH in that it utilizes a similar measuring system, and delivers millivolts, as does pH. ORP is a specialized measurement that can follow the progress of a chemical reaction that involves the loss and gain of electrons (Oxidation or Reduction) between species in solution. ORP only measures in millivolts, whereas pH measurements are related to a scale. ORP electrodes are the same type as pH.

- **Conductivity:** Conductivity is a common measuring technique. The range of conductivity is wide, from the purest water to the high conductivity of acid and alkali concentrations. Conductivity is a straightforward and reliable way to determine the purity of water, or the concentration of an acid or alkali. The principle of conductivity measurement for analysis is defined as the ability of a solution to conduct an electrical current between two electrodes. In a solution, the current flows by ion transport. Therefore, the higher the ion concentration, the more current flow. Chemical compounds which produce conducting solutions are called electrolytes.

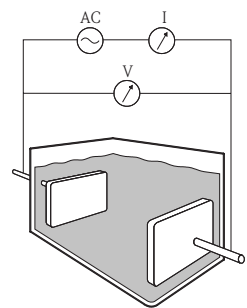

Endress+Hauser offers two basic types of sensors for conductivity measurement. The contacting (conductive) sensor and the electrode less (inductive) sensor.

Conductive sensor: The conductivity of liquids is measured with a measuring system that has two coaxially arranged electrodes like a capacitor. The electric resistance or its reciprocal value, the conductance G , is measured according to Ohm's law. The specific conductivity K is determined using the cell constant k that is dependent on the sensor geometry.

Inductive sensor: In inductive conductivity measurement, a transmitting coil generates a magnetic alternating field that induces an electric voltage in a liquid. The ions present in the liquid enable a current flow which increases with increasing ion concentrations.

The current in the liquid generates a magnetic alternating field in the receiving coil. The resulting current in the receiving coil is measured and used to determine the conductivity value. The conductivity serves as a measure of ion concentration.

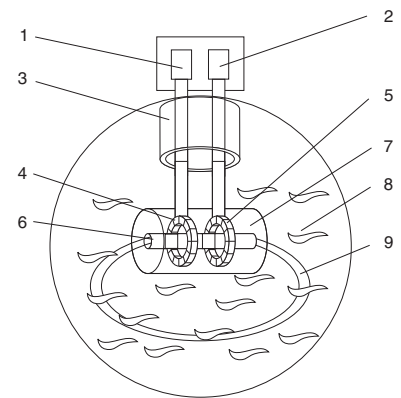

- 1 Oscillator
- 2 Receiver and signal processing
- 3 Cable
- 4 Primary winding
- 5 Secondary winding
- 6 Bore
- 7 Sensor housing
- 8 Process medium
- 9 Induced electric current

- **Chlorine:** Chlorine is used not only in your home to clean and disinfect, but is widely used throughout industry, especially in water/wastewater treatment. As a common last step of water treatment, a chlorination takes place, not only to destroy remaining bacteria but also to prevent the growth in the water pipe system which delivers clean water to households and industrial locations.

- **Dissolved Oxygen:** Oxygen is one of the basics of life, and is especially important in wastewater treatment. The level of dissolved oxygen determines the life span of micro-organisms in activated sludge basins which break down solids material. The measurement of dissolved oxygen is also important in lakes, streams and fish farming, to ensure healthy growth for the food industry. Pharmaceuticals and biotechnology also benefit from the use of measuring oxygen levels in controlled environments for micro-organism growth.

- **Turbidity:** Turbidity is the process of measuring solids content or suspended solids in wastewater, where large amounts of sludge must be handled. Sludge has to be removed in the primary clarifier, recirculated as activated sludge in the biology and separated from the treated water in the secondary clarifier. Most countries have very strict regulations regarding the maximum load of sludge particles in the effluent of the treatment plant. Getting rid of the sludge separated from the water is an important cost factor and will become more costly in the near future.

- **Chemical Analysis:** Chemical analysis is especially important to ensure clean water; not only for drinking, but in our rivers, lakes, and underground water sources. Endress+Hauser offers the Stamolys chemical analyzer, a self-contained sampler system which measure the correct values needed for efficient dosing of chemicals. The Stamolys CA 71 system is available for measurement of Nitrates, Phosphates, Chlorine, Ammonium, Aluminum, Chromate, Copper, Iron, Hardness, Hydrazine, Manganese, and Silicate.

Basic Analytical Measurement Technologies

- **Chlorine:** Chlorine is used not only in your home to clean and disinfect, but is widely used throughout industry, especially in water/wastewater treatment. Chlorine is a building block for nearly all chemical processes. It plays a vital role in the health of the population and in maintaining a clean and safe environment.

Chlorine sensors from Endress+Hauser are membrane-capped amperometric sensors. The membrane only allows hypochlorous acid molecules to diffuse through the membrane to react at the electrodes. Detected hypochlorous acid is a proportion of the active chlorine, which acts as a depolarizer at the cathode after diffusion by the membrane.

Total chlorine: Total chlorine is a weaker disinfectant than free chlorine, but lasts much longer. It is normally used in pipe lines, or in areas where it is too costly to maintain a free chlorine level. Total chlorine is the sum of total free chlorine and bound chlorine. Bound chlorine (chloramines) is not measured, its share can be determined numerically by subtracting free chlorine from total chlorine. Bound chlorine is no longer active and has no disinfectant effects. Forms of chlorine that have a disinfecting effect are: elemental chlorine Cl_2 , hypochlorous acid HOCl , hypochlorite ions OCl^- , and combinations thereof.

Free chlorine: The free chlorine form is the type that disinfects most effectively, but does not last as long. Sunlight, temperature fluctuations, pH changes and rain weaken the effects, especially in swimming pools or areas exposed to the environment. Hypochlorous acid HOCl proportion depends on the pH value. As pH value increases ($> \text{pH } 6$), HOCl dissociates into hypochlorite ions OCl^- and hydrogen ions H^+ . Only OCl^- is left at approximately 9.5 pH, where the disinfectant effect is extremely low. Normally, free chlorine is measured along with pH to maintain the most effective disinfecting properties.

- **Dissolved oxygen:** Dissolved oxygen (DO) is the term commonly used in liquid analytical work for the measurement of the amount of oxygen dissolved in a unit volume of water. It is an important indicator of the degree of usefulness of a sample of water for a specific application. The process requirements of a given application determine the level of dissolved oxygen that can be tolerated.

The primary application for parts-per-million (ppm) dissolved oxygen systems is measurement and control in aeration basins used in aerobic digesters in wastewater treatment plants. Correct levels of oxygen must be maintained to nourish the bacteria that are used to digest the waste. Endress+Hauser offers a single sensor style for measuring dissolved oxygen. The membrane covered sensor provides a sealed system which measures the oxygen molecules transferred through a gas permeable membrane to the electrodes.

- **Turbidity:** In order to ensure efficient water treatment, the primary sludge has to be removed. The task is to control a pump or slide valve. Most essential is to make sure that the sludge concentration is at least 1.5 to 2% DS (dry solids). A lower concentration will create tremendous costs in later stages of sludge treatment (e.g. sludge conditioning and de-watering).

Endress+Hauser incorporates optical technology which is most suitable for measuring the solids concentration in the sludge pipeline, and can be used easily to switch off the pump at too low concentrations. The 90° scattered light method with a measuring frequency in the near-infrared range of light (880 nm) guarantees a measurement of turbidity value under standardized, comparable conditions. The excitation radiation of an infrared transmitter strikes the medium at a defined beam angle. The different refractive indices of the entrance window and the measuring medium (water) are taken into account. Particles in the medium generate a scattered radiation which strikes the scattered light receiver at a defined angle. The measurement in the medium is constantly adjusted with the values of a reference receiver. For sludge level measurement in the primary clarifier, Endress+Hauser offers ultrasonic systems which provide non-contact continuous measurement.

- **Chemical analyzers:** The reduction and elimination of certain chemicals during the treatment process ensures that clean water is introduced into rivers and lakes from wastewater treatment facilities. Analyzers from Endress+Hauser are compact self-contained sampler and analyzer systems which are designed for specific chemicals, such as ammonium, nitrate, phosphate, etc. The measurement is accomplished using photometric technology. A sample is drawn into the analyzer and conditioned. The analyzer sample pump conveys a part of the filtrate to a mixing vessel where a reagent pump adds reagent at a specific ratio. As a result of the reaction, the sample turns a characteristic color. The photometer determines the sample absorption of an emitted light at a specific wavelength. The wavelength is parameter specific.

The absorption intensity is proportional to the concentration of the specified parameter in the sample. Additionally, the absorption of a reference light is determined to receive a genuine measuring result. The reference signal is subtracted from the measuring signal to prevent any effects due to turbidity, contamination and ageing of the LEDs. The temperature in the photometer is controlled thermostatically so that the reaction is reproducible and takes place within a short period of time.

Level Products

The specifications listed in the Product Overview pages are for basic comparison. Detailed specifications are available in the individual Technical Information documents. Specifications subject to change without notice.



Vibration



Liquiphant M					
	FTL 50 (compact)	FTL 51 (extended)	FTL 50 H (compact, hygienic/sanitary)	FTL 51 H (hygienic/sanitary, extended)	FTL 51 C (coated extended)
Application	Liquids		Liquids, hygienic		Liquids, corrosive
Measurement type	Point level, liquids		Point level, liquids		Point level, liquids
Sensor	Frequency shift tuning fork, compact version	Frequency shift tuning fork, extended forks to 115" (optional to 235")	Frequency shift tuning fork, compact version	Frequency shift tuning fork, extended forks to 115"	Frequency shift tuning fork, compact and extended forks to 115" (to 48" for enamel coating)
Output	FEL51: AC, load switched via thyristor FEL52: DC-PNP FEL54: DPDT relay FEL55: 8 to 16 mA FEL56: L-H edge NAMUR FEL58: H-L edge NAMUR with test button FEL57: PFM for separate switching unit FEL50A: Profibus PA FEL50D: Density (with FML621 density computer)		FEL51: AC, load switched via thyristor FEL52: DC-PNP FEL54: DPDT relay FEL55: 8 to 16 mA FEL56: L-H edge NAMUR FEL58: H-L edge NAMUR with test button FEL57: PFM for separate switching unit FEL50A: Profibus PA FEL50D: Density (with FML621 density computer)		FEL51: AC, load switched via thyristor FEL52: DC-PNP FEL54: DPDT relay FEL55: 8 to 16 mA FEL56: L-H edge NAMUR FEL58: H-L edge NAMUR with test button FEL57: PFM for separate switching unit FEL50A: Profibus PA FEL50D: Density (with FML621 density computer)
Power supply	FEL51: 19 to 253 VAC FEL52: 10 to 55 VDC (PNP) FEL54: 19 to 253 VAC, 19 to 55 VDC (relay) FEL55: 11 to 36 VDC (current) FEL56, 58, 57: NAMUR and PFM, requires separate power supply (e.g. FTL 325N / 325P) FEL50A: 9 to 32 VDC from bus FEL50D: powered by FML621 density computer		FEL51: 19 to 253 VAC FEL52: 10 to 55 VDC (PNP) FEL54: 19 to 253 VAC, 19 to 55 VDC (relay) FEL55: 11 to 36 VDC (current) FEL56, 58, 57: NAMUR and PFM, requires separate power supply (e.g. FTL 325N / 325P) FEL50A: 9 to 32 VDC from bus FEL50D: powered by FML621 density computer		FEL51: 19 to 253 VAC FEL52: 10 to 55 VDC (PNP) FEL54: 19 to 253 VAC, 19 to 55 VDC (relay) FEL55: 11 to 36 VDC (current) FEL56, 58, 57: NAMUR and PFM, requires separate power supply (e.g. FTL 325N / 325P) FEL50A: 9 to 32 VDC from bus FEL50D: powered by FML621 density computer
Ambient temperature	-40 to +160°F		-40 to +160°F		-60 to +160°F
Process temperature	-40 to +300°F		-40 to +300°F		-40 to +300°F (ECTFE coating, -40 to +250°F)
Process pressure	Maximum 1450 psi, threaded connections Flanges: pressure depends on flange selected and process temperature Maximum 230 psi, Tri-clamp		Maximum 1450 psi, threaded connections Flanges: pressure depends on flange selected and process temperature Maximum 230 psi, Tri-clamp Maximum 145 psi, Varivent Maximum 600 psi, 1" welded neck		ECTFE, PFA: -14 to +580 psi Enamel: -14 to +360 psi
Process connections	Threaded: 3/4" NPT, 1" NPT, 316L SS or Alloy C-4 ANSI flanges: 1" to 4" (Class 150, 300), 316L SS Tri-clamp: 1-1/2", 2", 316L SS		ANSI flanges: 1" to 4" (Class 150, 300), 316L SS Tri-clamp: 1-1/2", 2", 316L SS 1" flush mount, 316L SS (requires weld neck adapter) Varivent DN 40, 316L SS		ANSI flanges: 1" to 3", (Class 150, 300) 316L SS, coated (ECTFE, PFA) ANSI flanges: 2" (Class 150, 300) Alloy C-4, coated (Enamel)
Housings	Compact (welded 316L SS), Polyester (PBT) Aluminum, Dual-compartment Aluminum, 316L SS		Compact (welded 316L SS), Polyester (PBT) Aluminum, Dual-compartment Aluminum, 316L SS		Polyester (PTB), 316L SS, coated Aluminum, dual-compartment coated aluminum
Maximum viscosity	10,000 cSt		10,000 cSt		10,000 cSt
Function indication	Red, yellow, green LED's (depending on electronics)		Red, yellow, green LED's (depending on electronics)		Red, yellow, green LED's (depending on electronics)
Wetted material	316L SS or Alloy C4		316L SS or Alloy C4		316L SS or Alloy C4, coated (ECTFE, PFA, Enamel)
Approvals / certificates	FM, CSA, SIL 3		FM, CSA, SIL 3, 3-A, FDA compliant materials		FM, CSA, SIL 2, FDA compliant materials



FML 621 Density Computer	
	
Basic application	Density / concentration
Medium	Liquids
Housing	DIN rail or panel mount
Inputs	Pressure, temperature, FEL50D electronic insert (analog, digital, TC, RTD, mA, mV, V, pulse)
Outputs	4 to 20 mA, relays, pulse
Display / Local operation	160 x 80 dot matrix with rear illumination / 8 soft-key pushbuttons or RS 232/ RS 485
Interface	RS 232, RS 485, PROFIBUS-PA
Operating software	ReadWin 2000
Ambient temperature	-4 to 122°F
Power supply	90 to 250 VAC 20 to 36 VDC, 20 to 28 VAC
Standards / approvals	FM, CSA



NOTE: The FML621 density computer is only available for use with a Liquiphant M specified with the FEL50D electronics. The FEL50D electronics are not interchangeable with any other electronic insert.

Level limit switch / Power supply



Nivotester		
	FTL 325 P (intrinsically safe signal circuit, Liquiphant/Soliphant)	FTL 325 N (one and three channel amplifier for NAMUR)
		
Application	Liquids, solids	Liquids
Measurement type	Point level	Point level
Output	AC/DC, relays	AC/DC, relays
Input	PFM signal	NAMUR L-H edge
Power supply	85 to 253 VAC 20 to 60 VDC	85 to 253 VAC 20 to 60 VDC
Ambient temperature	-4 to +140°F	-4 to +140°F
Mounting	DIN rail	DIN rail
Function indication	Red, green, yellow LEDs	Red, green, yellow LEDs
Operation	Switches	Switches
Housing	Body, Polycarbonate Front cover, polypropylene	Body, Polycarbonate Front cover, polypropylene
Approvals / certificates	CE, FM, CSA, SIL 2	CE, FM, CSA, NAMUR

Liquiphant S High Temperature		
	FTL70 (compact)	FTL71 (extended)
		
Application	Liquids	Liquids
Measurement type	Point level, liquids	Point level, liquids
Sensor	Frequency shift tuning fork, compact version	Frequency shift tuning fork, extended forks to 115"
Output	FEL51: AC, load switched via thyristor FEL52: DC-PNP FEL54: DPDT relay FEL55: 8 to 16 mA FEL56: L-H edge NAMUR FEL58: H-L edge NAMUR with test button FEL57: PFM for separate switching unit FEL50A: Profibus® PA	
Power supply	FEL51: 19 to 253 VAC FEL52: 10 to 55 VDC (PNP) FEL54: 19 to 253 VAC, 19 to 55 VDC (relay) FEL55: 11 to 36 VDC (current) FEL56, 57, 58: NAMUR and PFM, requires separate power supply (e.g. FTL325N/325P) FEL50A: 9 to 32 VDC from bus	
Ambient temperature	-40 to +160°F	-40 to +160°F
Process temperature	-40 to +450°F/-40 to +540°F	-40 to +450°F/-40 to +540°F
Process pressure	Maximum 1450 psi, threaded connections Flanges: Pressure depends on flange selected and process temperature	
Process connections	Threaded: 3/4" NPT, 1" NPT, 316L SS or Alloy C-4 ANSI flanges: 1" to 4" (Class 150, 300, 600) 316L SS RF, optional Alloy C 4 plating	
Housings	Polyester (PBT), Aluminum, Dual-compartment aluminum	
Maximum viscosity	10,000 cSt	10,000 cSt
Function indication	Red, yellow, green LEDs (depending on electronics)	
Wetted material	316L SS or Alloy C4	316L SS or Alloy C4
Approvals/certificates	FM, CSA, SIL 3	FM, CSA, SIL 3

Liquiphant T			
	FTL20	FTL20H	FTL260
			
Application	Liquids	Liquids	Liquids
Measurement type	Point level, liquids	Point level, liquids	Point level, liquids
Sensor	Frequency shift tuning fork	Frequency shift tuning fork	Frequency shift tuning fork
Output	AC DC-PNP AS-i	AC DC-PNP Asi	AC DC-PNP
Power supply	19 to 253 VAC 10 to 35 VDC (PNP) 24.5 to 31 VDC (AS-i)	19 to 253 VAC 10 to 35 VDC (PNP) 24.5 to 31 VDC (AS-i)	19 to 253 VAC 10 to 55 VDC (PNP)
Ambient temperature	-40 to +158°F (AS-i-bus, -13 to +158°F)	-40 to +158°F (AS-i-bus, -13 to +158°F)	-40 to +160°F
Process temperature	-40 to +300°F	-40 to +300°F	-40 to +300°F
Process pressure	-14.5 to 580 psig	-14.5 to 580 psig	Max. 360 psi
Process connections	Threaded: 1/2" 3/4" NPT	Tri-Clamp® ISO2852 Dairy Coupling Flush mount solutions	Threaded: 1" NPT
Maximum viscosity	10,000 cSt	10,000 cSt	10,000 cSt
Function indication	Red and green LEDs	Red and green LEDs	Red and green LEDs
Wetted material	316L SS	316L SS	316 SS
Approvals/certificates	UL, CSA US, AS-i	UL, CSA US, AS-i	CSA general purpose

Liquiphant Failsafe			
	FTL80	FTL81	FTL85
			
Measuring Principle	Vibration Liquids	Vibration Liquids	Vibration Liquids
Characteristic / Application	Compact point level switch for MIN and MAX safety applications up to SIL3	Reliable point level switch with extension pipe for MIN and MAX safety applications up to SIL3	Coated point level switch for MIN and MAX
Supply / Communication	2-wire 4 to 20 mA	2-wire 4 to 20 mA	2-wire, 4 to 20 mA
Ambient temperature	-76°F to +160°F	-76°F to +160°F	-58°F to +160°F
Process temperature	-76°F to +540°F	-76°F to +540°F	-58°F to +300°F
Process pressure absolute / max. overpressure limit	Vacuum to 1450 psi (100 bar)	Vacuum to 1450 psi (100 bar)	Vacuum to 580 psi (40 bar)
Min. density of medium	Density from 0.4 SGU (0.4 g/cm3)	Density from 0.4 SGU (0.4 g/cm3)	Density from 0.4 SGU (0.4 g/cm3)
Main wetted parts	316L, Alloy C	316L, Alloy C	With high corrosion-resistant coating made of enamel, ECTFE and various PFA materials
Process connection	Flange: ASME 1" to 4", DN25 to DN100, JIS 10K to 20K Thread: G3/4, G1, R3/4, R1, MNPT3/4, MNPT1	Flange: ASME 1" to 4", DN25 to DN100, JIS 10K to 20K Thread: G3/4, G1, R3/4, R1, MNPT3/4, MNPT1	Flange: ASME 1" to 4", DN25 to DN100, JIS 10K to 20K
Sensor length	Compact	Extension pipe up to 9.8 ft. (3 m)	Extension pipe up to 9.8 ft. (3 m)
Output	2-wire 4 to 20 mA	2-wire 4 to 20 mA	2-wire 4 to 20 mA
Certificates / Approvals	ATEX, FM, IECEx Overfill prevention WHG EN10204-3.1 Material NACE	ATEX, FM, IECEx Overfill prevention WHG EN10204-3.1 Material NACE	ATEX, FM, IECEx Overfill prevention WHG EN10204-3.1 Material NACE
Components	Nivotester FTL825, Transmitter	Nivotester FTL825, Transmitter	Nivotester FTL825, Transmitter

Liquiphant Failsafe	
	FTL825 Nivotester
	
Measuring Principle	Vibration Liquids
Characteristic / Application	Failsafe level transmitter point level. Connection to FTL80/81/85 Permanent self-monitoring, LIVE-signal
Supply / Communication	85 - 253 VAC/DC 20 - 30 VAC/20 - 60 VDC
Ambient temperature	-4°F to +140°F -20°C to +60°C
Output	2x SPST safety contact point level 1x SPST signal contact 1x SPDT fault contact
Certificates / Approvals	ATEX, FM, IECEx Overfill prevention WHG
Specialties	SIL 3 according to IEC61508
Instrumentation	Separate instrumentation





	Soliphant M	Soliphant T
		
Application	Solids	Solids
Measurement type	Point level, fine-grained bulk solids	Point level, fine or coarse-grained bulk solids
Sensor	Frequency shift tuning fork	Frequency shift vibrating rod
Output (dependent on electronics insert selected)	AC (FEM51) DC-PNP (FEM52) AC/DC, relay output (FEM54) DC, 8/16 mA (FEM55) PFM (FEM57) output to Nivotester switch unit (i.e. FTL325) NAMUR, H-L edge (FEM58)	DC PNP AC/DC, relay output
Power supply	19 to 253 VAC 10 to 55 VDC (PNP) 19 to 253 VAC / 55 VDC 11 to 36 VDC	10 to 45 VDC (PNP) 19 to 253 VAC / 19 to 55 VDC
Ambient temperature	-58 to +158°F, -40 to +158°F (F16 polyester housing)	-40 to +158°F
Housing	Polyester, Aluminum, Dual-compartment aluminum, 316 SS	Polyester, Aluminum
Process temperature	-58 to +302°F	-40 to +300°F
Process pressure	FTM50, 51: -14.5 to 362 psi FTM52: 29 psi	-14.5 to 362 psi
Process connections	Threaded: 1-1/4", 1-1/2" NPT, 304 SS Flange: 2", 3", 4" 150 ANSI, 316 SS 2" Tri-clamp®, 316L SS	Threaded: 1-1/4" or 1-1/2" NPT, 316 SS
Measured detection range	FTM50: dependent on mounting location, 4" fork FTM51: extended tube, 6" up to 13 feet FTM52: extension cable, up to 65 feet	Dependent on mounting location FTM21: extension pipe; 20, 40 or 60 inch
Maximum particle size	0.4"	≤ 0.98"
Function indication	Red and green LEDs	Green and yellow LEDs
Wetted material	Threaded process connection: 316L SS Extension tube: 316L SS Flanges: 316L SS Cable: braided steel, polyurethane coated Fork: 316L SS	316L SS
Approvals/certificates	CE, SIL 2 combination FM/CSA	CE, combination FM/CSA



Conductivity

	Liquipoint
	
Measuring Principle	Conductive
Characteristic / Application	Compact point level switch for use in pipes and in storage, mixing and process vessels with or without an agitator, active buildup compensation, flush mounting
Supply / Communication	10 to 30 V DC
Ambient temperature	-40 to 158°F (-40 to 70°C)
Process temperature	Standard: -20 to 100°C Cleaning: -4 to 302°F for 1h
Process pressure absolute / max. overpressure limit	0 to 362.5 psi abs / 0 to 25 bar abs
Min. conductivity of medium	1µS/cm
Main wetted parts	Sensor: 316L Sensor isolation: PEEK
Process connection	Thread G1, G1/2, G3/4, M24
Process connection hygienic	Clamp ISO 2852 1 to 1 1/2", 2", DIN11851 Pipe union
Output	DC PNP
Approvals/certificates	EHEDG, 3-A
Specialties	CIP and SIP suitable
Application limits	Conductive foam is recognized as a liquid
Instrumentation	Compact
Electronic insert	DC PNP

	Liquipoint T
	
Application	Liquids
Measurement type	Multiple point level
Output	AC/DC, relay DC-PNP NAMUR
Measured detection range	FTW31 rod: 4" to 158" FTW32 cable: 10" to 590"
Power supply	20 to 253 VAC/20 to 55 VDC 10.8 to 45 VDC (PNP) NAMUR requires separate power, e.g. FTW325
Ambient temperature	-40 to +160°F NAMUR, -40 to +140°F
Process temperature	-40 to +212°F
Process pressure	-14.5 to 145 psi
Process connection	Threaded: 1-1/2" NPT
Wetted material	Rod probes: 316L SS, PP insulation Cable probes: 316Ti SS, FEP insulation
Function indication	Red, yellow, green LEDs
Housing	Compact: PBT Remote: housing PPS; cover PBT
Approvals/certificates	CE



Capacitance

	Nivector	Minicap		Solicap M	Solicap S
	FTC968 	FTC260 (compact version) 	FTC262 (cable version) 	FTI55 / FTI56 (limit detection switch) 	FTI77 (limit detection switch) 
Application	Powders, granules, pellets	Bulk solids, liquids	Bulk solids	Bulk solids	Bulk solids / high temperature
Measurement type	Point level	Point level	Point level	Point level	Point level
Output	AC DC-PNP	AC/DC, relay DC-PNP	AC/DC, relay DC-PNP	AC - 2 wire (FEI51) DC - PNP (FEI52) 3-12 VDC (FEI53) AC/DC, relay output (FEI54) 8/16 mA (FEI55) PFM (FEI57S) NAMUR H-L Edge (FEI58)	AC - 2 wire (FEI51) DC - PNP (FEI52) 3-12 VDC (FEI53) AC/DC, relay output (FEI54) 8/16 mA (FEI55) PFM (FEI57S) NAMUR H-L Edge (FEI58)
Measured detection range	Dependent on mounting location	Dependent on mounting location	236"	Rod probe: up to 13 ft Cable probe: up to 72 ft	Sword probe: up to 40 inches Cable probe: up to 65 ft
Power supply	21 to 253 VAC 10 to 55 VDC (PNP)	20 to 253 VAC 20 to 55 VDC 10.8 to 45 VDC (PNP)	20 to 253 VAC 20 to 55 VDC 10.8 to 45 VDC (PNP)	FEI52: 10 to 55 VDC FEI53: 14.5 VDC FEI54: 19 to 253 VAC, 50/60 Hz or 19 to 55 VDC FEI55: 11 to 36 VDC FEI57S: 9.5 to 12.5 VDC FEI58: powered by FTL325N or 375N	FEI52: 10 to 55 VDC FEI53: 14.5 VDC FEI54: 19 to 253 VAC, 50/60 Hz or 19 to 55 VDC FEI55: 11 to 36 VDC FEI57S: 9.5 to 12.5 VDC FEI58: powered by FTL325N or 375N
Ambient temperature	-4 to +140°F	-40 to +160°F	-40 to +160°F	-58 to +158°F	-58 to +158°F
Process temperature	-4 to +176°F	-40 to +250°F	-40 to +160°F	-58 to +356°F	-58 to +752°F
Process pressure	-14.5 to 87 psi	-14.5 to 1450 psi	-14.5 to 90 psi	-14.5 to 360 psi	-14.5 to 145 psi
Process connections	Threaded: 1" BSPP with two hex lock nuts	Threaded: 1" NPT	Threaded: 1-1/2" NPT	Threaded: 1-1/2" NPT Flange: 2", 3" or 4"	Threaded: 1-1/2" NPT Flange: 2", 3" or 4"
Maximum particle size	0.4"	1.2"	1.2"	N/A	N/A
Function indication	Red LED	Red and green LEDs	Red and green LEDs	Red, green and yellow LEDs	Red, green and yellow LEDs
Wetted material	Blue PC, lock nuts black PA	Probe: Polyphenylene sulphide (FDA listed material)	Cable: steel coated with high density PE Probe: Polyphynylene sulphide (FDA listed material)	Rod, partially insulated: PPS, 316L SS Rod: fully insulated: PE, galv. steel Cable, partially insulated: PTFE, 316L SS Cable, fully insulated: PA, valv. steel	Sword, process connection, inactive length, tensioning weight for cable probe: 316L SS or steel Cable: zinc coated steel or 316L SS
Housing	PC	Polyester	Polyester	Polyester, Aluminum Dual-compartment aluminum, 316 SS	Polyester, Aluminum Dual-compartment aluminum, 316 SS
Approvals/certificates	CE	CE, FM, CSA	CE, FM, CSA	CD, combination FM/CSA, SIL2/SIL3 (with FEI55 insert)	CD, combination FM/CSA, SIL2/SIL3 (with FEI55 insert)





Liquicap M		
	FTI51 / FTI52 (limit detection switch)	FMI51 / FMI52 (continuous level detection)
		
Application	Liquids	Liquids
Measurement type	Point level	Continuous level
Output	DC-PNP (FEI52) 3-12 VDC (FEI53) AC/DC, relay output (FEI54) 8/16 mA (FEI55) PFM (FEI57S)	4 to 20 mA HART® (FEI50H) PFM (FEI57C)
Measured detection range	Rod probe: up to 13 ft / Cable probe: up to 33 ft	Rod probe: up to 13 ft / Cable probe: up to 72 ft
Power supply	FEI52: 10 to 55 VDC FEI53: 14.5 VDC FEI54: 19 to 253 VAC, 50/60 Hz or 19 to 55 VDC FEI55: 11 to 36 VDC FEI57S: 9.5 to 12.5 VDC	FEI50H: 12 to 36 VDC FEI57C: 14.8 VDC
Ambient temperature	-58 to +158°F	-58 to +158°F
Process temperature	-112 to +392°F	-112 to +392°F
Process pressure	-14.5 to 1450 psi	-14.5 to 1450 psi
Process connections	Threaded: 1/2", 3/4", 1", 1-1/2" Flange: 1" to 6" Tri-clamp®: 1", 1-1/2", 2"	Threaded: 1/2", 3/4", 1", 1-1/2" Flange: 1" to 6" Tri-clamp®: 1", 1-1/2", 2"
Maximum particle size	N/A	N/A
Function indication	Red, green, yellow LEDs	Red and green LED, HART®, local display
Wetted material	Rod: 316L SS; insulated rod, PFA or PTFE coated 316L SS Cable: 316 SS; insulated cable, PFA or FEP coated 316 SS	Rod: 316L SS; insulated rod, PFA or PTFE coated 316L SS Cable: 316 SS; insulated cable, PFA or FEP coated 316 SS
Housing	Polyester, Aluminum, Dual-compartment aluminum, 316 SS	Polyester, Aluminum, Dual-compartment aluminum, 316 SS
Approvals/certificates	CE, combination FM/CSA, SIL2	CE, combination FM/CSA, SIL2



Liquicap T	
	FMI21
	
Application	Liquids
Measurement type	Capacitance, continuous
Output	4 to 20 mA 0 to 100%
Measured detection range	6" to 98"
Power supply	10 to 30 VDC
Ambient temperature	-40 to +160°F
Process temperature	-40 to +212°F
Process pressure	-14.5 to 145 psi
Process connections	Threaded: 1-1/2" NPT, PPS
Wetted material	Rod probes: 316L SS, optional carbon fiber (CPC) Probe insulation: PP
Function indication	Red and green LEDs, optional display
Housing	PBT-FT Cover PBT Cover with sight glass, PA
Approvals/certificates	CE





Transmitter/Limit Switch





Nivotester			
	FTC625 (intrinsically safe signal circuit)	FTC325 (intrinsically safe signal circuit)	FTW325 (intrinsically safe signal circuit)
			
Application	Liquids	Liquids, solids	Liquids
Measurement type	Capacitance, point level	Capacitance, point level	Conductivity, point level
Output	Relay, switch	One SPDT, one SPST	Two relays, SPDT
Input	PFM signal	2-wire, PFM, 3-wire analog	NAMUR
Power supply	85 to 253 VAC 20 to 30 VAC / 20 to 60 VDC	85 to 253 VAC 20 to 30 VAC / 20 to 60 VDC	85 to 253 VAC 20 to 30 VAC / 20 to 60 VDC
Ambient temperature	-4 to +140°F	-4 to +140°F	
Mounting	DIN rail	DIN rail	DIN rail
Function indication	Red, green, yellow LEDs	Red, green, yellow LEDs	Red, green, yellow LEDs
Operation	Switches, RS485 Remote with FieldCare software	Switches	Switches
Housing	Body, Polycarbonate Front cover, polypropylene	Body, Polycarbonate Front cover, polypropylene	Body, Polycarbonate Front cover, polypropylene
Approvals/Certificates	CE, FM, CSA	CE, FM, CSA (3-wire, non-hazardous)	CE, FM, CSA, NAMUR

Radar

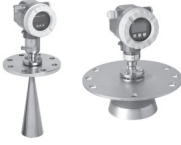



Micropilot				
	FMR50	FMR51	FMR52	FMR53
				
Application	Liquids	Liquids	Liquids	Liquids
Measurement type	Radar, non contact, continuous	Radar, non contact, continuous	Radar, non contact, continuous	Radar, non contact, continuous
Max measured range	98 ft	131 ft, 230 ft enhanced dynamics	131 ft, 197 ft enhanced dynamics	66 ft
Output	4 to 20 mA, HART®	4 to 20mA HART®, Profibus®, FOUNDATION™ Fieldbus	4 to 20mA HART®, Profibus®, FOUNDATION™ Fieldbus	4 to 20mA HART®, Profibus®, FOUNDATION™ Fieldbus
Antenna type	Encapsulated PVDF or PP clad horn antenna	Horn: 1-1/2", 2", 3", 4"	Horn: PTFE disk, 2" and 3"	PFTE Rod antenna
Power supply	16-32 VDC	16-32 VDC	16-32 VDC	16-32 VDC
Ambient temperature	-40 to +176°F	-40 to +176°F	-40 to +176°F	-40 to +176°F
Process temperature	-40 to +266°F	-321 to +842°F	-40 to +392°F	-40 to +302°F
Process connections	G1-1/2, MNPT1-1/2, Flange (3" to 6")	MNPT1-1/2", Flange (2" to 6"), Tri-Clamp®	Flange 2" to 6", Tri-Clamp®	MNPT1-1/2, Flange (2" to 6")
Wetted material	PVDF, PTFE, Viton, PP, PBT	316L, Alloy C, PTFE, Ceramic	PTFE	PVDE, PTFE
Operation	4 to 20 mA, HART®	HART®, Profibus®, FOUNDATION™ Fieldbus, VU331 display	HART®, Profibus®, FOUNDATION™ Fieldbus, VU331 display	HART®, Profibus®, FOUNDATION™ Fieldbus, VU331 display
Housing	PTB Plastic, Dual compartment, Aluminum, Dual compartment	316L, Dual compartment, Aluminum, Dual compartment	316L, Dual compartment, Aluminum, Dual compartment	316L, Dual compartment, Aluminum, Dual compartment
Approvals / certificates	ATEX, SIL, CE	ATEX, FM, CSA, CE, SIL	ATEX, FM, CSA, CE, SIL	ATEX, FM, CSA, CE, SIL

Micropilot				
	FMR54	FMR56	FMR57	
				
Application	Liquids	Liquids	Liquids	
Measurement type	Radar, non contact, continuous	Radar, non contact, continuous	Radar, non contact, continuous	
Max measured range	66 ft	98 ft	230 ft	
Output	4 to 20mA HART®, Profibus®, FOUNDATION™ Fieldbus	4 to 20mA HART®, Profibus®, FOUNDATION™ Fieldbus	4 to 20mA HART®, Profibus®, FOUNDATION™ Fieldbus	
Antenna type	Horn: 3", 4", 6", 8", 10"	Horn: PP 3" and 4"	Parabolic 8" and 10", Horn 3" and 4"	
Power supply	16-32 VDC	16-32 VDC	16-32 VDC	
Ambient temperature	-40 to +176°F	-40 to +176°F	-40 to +176°F	
Process temperature	-321 to +752°F	-40 to +176°F	-40 to +752°F	
Process connections	Flange(3" to 12")	Flange 3" to 6", Mounting Bracket	MNPT1-1/2, Flange 3" and 4", UNI 8" and 10"	
Wetted material	316L	PP, UP	316L, PTFE, PEEK, Polyamid	
Operation	HART®, Profibus®, FOUNDATION™ Fieldbus, VU331 display	HART®, Profibus®, FOUNDATION™ Fieldbus, VU331 display	HART®, Profibus®, FOUNDATION™ Fieldbus, VU331 display	
Housing	316L, Dual compartment, Aluminum, Dual compartment	Aluminum, Dual compartment	316L, Dual compartment, Aluminum, Dual compartment	
Approvals / certificates	ATEX, FM, CSA, CE, SIL	ATEX, FM, CSA, CE, SIL	ATEX, FM, CSA, CE, SIL	



Micropilot M						
	FMR 230	FMR 231	FMR 240	FMR 244	FMR 245	FMR 250
						
Application	Liquids, pastes, slurries	Liquids, pastes, slurries	Liquids, pastes, slurries	Liquids, pastes, slurries	Liquids, pastes, slurries	Bulk solids, liquids
Measurement type	Radar, non-contact, continuous	Radar, non-contact, continuous	Radar, non-contact, continuous	Radar, non-contact, continuous	Radar, non-contact, continuous	Radar, non-contact, continuous
Maximum measured range	65 ft	65 ft	65 ft	65 ft	229 ft	230 ft
Output	4 to 20 mA, HART, Profibus, Foundation Fieldbus	4 to 20 mA, HART, Profibus, Foundation Fieldbus	4 to 20 mA, HART, Profibus, Foundation Fieldbus	4 to 20 mA, HART, Profibus, Foundation Fieldbus	4 to 20 mA, HART, Profibus, Foundation Fieldbus	4 to 20 mA, HART
Antenna type	Horn: 3", 4", 6", 8", 10"	Rod: 14" to 21"	Horn: 1-1/2", 2", 3", 4" Wave guide antenna: 12 to 150"	Horn: enclosed PTFE, 1-1/2"	Horn: disk, PTFE clad, 2" and 3"	Horn: 3", 4" Parabolic: 8", 10"
Power supply	16 to 32 VDC	16 to 32 VDC	16 to 32 VDC	16 to 32 VDC	16 to 32 VDC	16 to 32 VDC
Ambient temperature	-40 to +176°F	-40 to +176°F	-40 to +176°F	-40 to +176°F	-40 to +176°F	-40 to +176°F
Process temperature	-76 to +752°F	-40 to +302°F	-40 to +302°F	-40 to +266°F	-40 to +302°F	-40 to +392°F
Process pressure	Vacuum to 2320 psi	Vacuum to 580 psi	Vacuum to 580 psi	Vacuum to 43 psi	Vacuum to 232 psi	Vacuum to 232 psi
Process connections	3" to 10" ANSI flanges 3" Tri-clamp	1-1/2" threaded 2" to 6" ANSI flanges 2", 3" Tri-clamp	1-1/2" threaded 2" to 6" ANSI flanges 3" Tri-clamp	1-1/2" threaded	2" to 6" ANSI flanges 2" or 3" Tri-clamp	1-1/2" NPT 3" or 4" ANSI flange 4", 8" or 10" universal flange
Wetted material	Enamel, PTFE, 316Ti SS, Ceramic, 316 SS with PTFE	PVDF + PTFE, 317 SS + PTFE, PTFE	PTFE, 316L SS, Alloy C 22	PTFE, PVDF	316 L SS with PTFE disk	316 L SS, PEEK
Operation	HART, Profibus-PA, Foundation Fieldbus, VU 331 display module	HART, Profibus-PA, Foundation Fieldbus, VU 331 display module	HART, Profibus-PA, Foundation Fieldbus, VU 331 display module	HART, Profibus-PA, Foundation Fieldbus, VU 331 display module	HART, Profibus-PA, Foundation Fieldbus, VU 331 display module	HART, Profibus-PA, Foundation Fieldbus, VU 331 display module
Housing	Aluminum, Aluminum with separate connection compartment, 316 SS	Aluminum, Aluminum with separate connection compartment, 316 SS	Aluminum, Aluminum with separate connection compartment, 316 SS	Aluminum, Aluminum with separate connection compartment	Aluminum, Aluminum with separate connection compartment, 316 SS	Aluminum, Aluminum with separate connection compartment, 316 SS
Approvals / certificates	CE, FM, CSA, SIL 2, FCC	CE, FM, CSA, SIL 2, FCC	CE, FM, CSA, SIL 2, FCC	CE, FM, CSA, SIL 2, FCC	CE, FM, CSA, SIL 2, FCC	CE, FM, CSA, FCC

Micropilot S				
	FMR 530	FMR 532	FMR 533	FMR 540
				
Application	Liquids, custody transfer	Liquids, custody transfer	Liquids, custody transfer	Liquids, custody transfer
Measurement type	Radar, non-contact, continuous	Radar, non-contact, continuous	Radar, non-contact, continuous	Radar, non-contact, continuous
Maximum measured range	65 ft	125 ft	131 ft	Horn: 98 ft Parabolic: 131 ft
Output	4 to 20 mA, HART	4 to 20 mA, HART	4 to 20 mA, HART	4 to 20 mA, HART
Antenna type	Horn: 3", 4", 6", 8", 10"	Planar antenna: 6", 8", 10", 12"	Parabolic antenna: 20"	Horn: 4" Parabolic: 8", 10"
Power supply	16 to 32 VDC	16 to 32 VDC	16 to 32 VDC	16 to 36 VDC
Ambient temperature	-40 to +176°F	-40 to +176°F	-40 to +176°F	-40 to +176°F
Process temperature	-40 to +392°F	-40 to +302°F	-40 to +392°F	-40 to +392°F
Process pressure	14.5 to 580 psi	14.5 to 362 psi	14.5 to 232 psi	-14.5 to 232 psi, horn antenna -14.5 to 87 psi, parabolic
Process connections	3" to 10" ANSI flanges	6" to 12" ANSI flanges 6" to 12" Uniflange	6" to 10" ANSI flanges 6" Uniflange	4" or 6" ANSI flange 6", 8" or 10" Uniflange
Wetted material	PTFE, 316Ti SS	HNBR, 316L SS	PTFE, 316L SS	Horn: PEEK, 316L SS Parabolic: PTFE, 316L SS
Operation	HART, VU 331 display module, FieldCare software	HART, VU 331 display module, FieldCare software	HART, VU 331 display module, FieldCare software	HART, VU 331 display module, FieldCare software
Housing	Aluminum with separate connection compartment	Aluminum with separate connection compartment	Aluminum with separate connection compartment	Aluminum with separate connection compartment
Approvals / certificates	CE, FM, CSA, Nmi, PTB	CE, FM, CSA, Nmi, PTB	CE, FM, CSA, Nmi, PTB	CE, FM, CSA, Nmi, PTB

Guided radar



Levelflex					
	FMP 50 (Rod / cable probe)	FMP 51, 52, 54			FMP 53 (Rod probe)
					
		FMP 51 (rod, cable, coax)	FMP 52 (rod, cable)	FMP 54 (rod, cable, coax)	
Application	Liquids	Liquids	Liquids, aggressive	Liquids, high temperature/pressure	Liquids, hygienic
Measurement type	Radar, continuous level	Radar, continuous level/interface	Radar, continuous level/interface	Radar, continuous level/interface	Radar, continuous
Measured range	Liquids: 39 ft Max. rod length, 13 ft Max. cable length, 40 ft	Liquids: 148 ft Max. rod length, 33 ft Max. cable length, 148 ft Max. coax length, 20 ft	Liquids: 148 ft Max. rod length, 13 ft Max. cable length, 148 ft	Liquids: 148 ft Max. rod length, 33 ft Max. cable length, 148 ft Max. coax length, 20 ft	Liquids: maximum 20 ft
Output	4 to 20 mA, HART Profibus PA	4 to 20 mA, HART Profibus PA	4 to 20 mA, HART Profibus PA	4 to 20 mA, HART Profibus PA	4 to 20 mA, HART Profibus PA
Power supply	HART 2-wire: 11.5 35 VDC HART 4-wire: 90 to 253 VAC, 10.4 to 48 VDC Profibus, 2-wire: 9 to 32 VDC	HART 2-wire: 11.5 35 VDC HART 4-wire: 90 to 253 VAC, 10.4 to 48 VDC Profibus, 2-wire: 9 to 32 VDC	HART 2-wire: 11.5 35 VDC HART 4-wire: 90 to 253 VAC, 10.4 to 48 VDC Profibus, 2-wire: 9 to 32 VDC	HART 2-wire: 11.5 35 VDC HART 4-wire: 90 to 253 VAC, 10.4 to 48 VDC Profibus, 2-wire: 9 to 32 VDC	HART 2-wire: 11.5 35 VDC HART 4-wire: 90 to 253 VAC, 10.4 to 48 VDC Profibus, 2-wire: 9 to 32 VDC
Ambient temperature	-40 to +176°F With display: -4 to +158°F	-40 to +176°F With display: -4 to +158°F	-40 to +176°F With display: -4 to +158°F	-40 to +176°F With display: -4 to +158°F	-40 to +176°F With display: -4 to +158°F
Process temperature	-4 to +176°F	-40 to +392°F depending on O-ring material	-58 to +392°F	-321 to +842°F	-4 to +302°F, with FFKM o-ring -4 to +266°F, with EPDM o-ring
Process pressure	Vacuum to 87 psi	Vacuum to 580 psi	Vacuum to 580 psi	Vacuum to 5800 psi	Vacuum to +232 psi
Process connections	3/4" NPT	3/4", 1-1/2" NPT Flange, 1-1/2" to 8" (150 lb to 300 lb ANSI only)	1-1/2", 2" 3" Tri-clamp Flange, 1-1/2", 2", 3" 4" (150 lb to 300 lb ANSI only)	1-1/2" NPT Flange, 2", 3", 4" (300 lb to 1500 lb ANSI only)	1" to 1-1/2", 2" or 3" Tri-clamp SMS, DIN and NEMUO Bio process connections
Wetted material	316L SS	316L SS, Alloy C, PTFE	316L SS, PTFE	316L SS, PTFE	Probe, 316L SS
Operation	4-line LCD with 3 pushbuttons, HART, Profibus-PA	4-line LCD with 3 pushbuttons, HART, Profibus-PA	4-line LCD with 3 pushbuttons, HART, Profibus-PA	4-line LCD with 3 pushbuttons, HART, Profibus-PA	4-line LCD with 3 pushbuttons, HART, Profibus-PA
Housing	PTB plastic, dual compartment Aluminum, dual compartment	PTB plastic, dual compartment Aluminum, dual compartment 316L SS, dual compartment	PTB plastic, dual compartment Aluminum, dual compartment 316L SS, dual compartment	PTB plastic, dual compartment Aluminum, dual compartment 316L SS, dual compartment	PTB plastic, dual compartment Aluminum, dual compartment
Approvals / certificates	CE, FM, CSA, SIL 3	CE, FM, CSA, SIL 3	CE, FM, CSA, SIL 3, 3-A, FDA	CE, FM, CSA, SIL 3	CE, FM, CSA, SIL 3, ASME BPE and USP Class VI, FDA, 3-A

Levelflex	
	FMP 55 (Rod / cable / Coax)
	
Application	Liquids, level and interface
Measurement type	Radar / capacitance, continuous
Measured range	Liquids: 33 ft Max. rod length, 13 ft Max. cable length, 33 ft Max. coax length, 20 ft
Output	4 to 20 mA, HART Profibus-PA
Power supply	HART 2-wire: 11.5 35 VDC HART 4-wire: 90 to 253 VAC, 10.4 to 48 VDC Profibus, 2-wire: 9 to 32 VDC
Ambient temperature	-40 to +176°F
Process temperature	-58 to +392°F
Process pressure	-14.5 to 580 psi
Process connections	1-1/2" to 6" 150 lb ANSI RF flange, PTFE coated 1" to 4" 300 lb ANSI RF flange, PTFE coated
Wetted material	316L SS
Operation	4-line LCD 3 keys, HART, Profibus-PA Remote operation via HART, FieldCare, AMS Device Manager, SIMATIC PDM
Housing	PTB plastic, dual compartment Aluminum, dual compartment 316L SS, dual compartment
Approvals / certificates	CE, FM, CSA, SIL 3

Levelflex		
	FMP 56, FMP 57	
		
	FMP 56 (cable)	FMP 57 (rod, cable)
Application	Solids, level	Solids, level
Measurement type	Radar, continuous	Radar, continuous
Measured range	Solids, 40 ft Max. cable length, 40 ft	Solids, 40 ft Max. rod length, 13 ft Max. cable length, 148 ft
Output	4 to 20 mA, HART Profibus-PA	4 to 20 mA, HART Profibus-PA
Power supply	HART 2-wire: 11.5 35 VDC HART 4-wire: 90 to 253 VAC, 10.4 to 48 VDC Profibus, 2-wire: 9 to 32 VDC	HART 2-wire: 11.5 35 VDC HART 4-wire: 90 to 253 VAC, 10.4 to 48 VDC Profibus, 2-wire: 9 to 32 VDC
Ambient temperature	-40 to +176°F With display: -4 to +158°F	-40 to +176°F With display: -4 to +158°F
Process temperature	-22 to +248°F, with FFKM o-ring -40 to +248°F, with EPDM o-ring	-22 to +302°F, with FFKM o-ring -40 to +248°F, with EPDM o-ring
Process pressure	-14.5 to 232 psi	-14.5 to 232 psi
Process connections	3/4" NPT	1-1/2" NPT Flange, 1-1/2" to 8" (150 lb ANSI)
Wetted material	316L SS	316L SS
Operation	4-line LCD with 3 pushbuttons, HART, Profibus-PA	4-line LCD with 3 pushbuttons, HART, Profibus-PA
Housing	PTB plastic, dual compartment Aluminum, dual compartment 316L SS, dual compartment	PTB plastic, dual compartment Aluminum, dual compartment 316L SS, dual compartment
Approvals / certificates	CE, FM, CSA, SIL 3	CE, FM, CSA, SIL 3

NOTE: FMP 5x Levelflex products replace the FMP 4x products.

Microwave barrier

Soliwave M FQR50 / FDR50	
	<div style="display: flex; justify-content: space-around;"> <div style="text-align: center;"> FQR50 Emitter  </div> <div style="text-align: center;"> FDR50 Receiver  </div> </div>
Application	Solids (wood chips, wood dust, flour, plaster, gravel, sand, dried powders, bags, boxes)
Measurement type	Non-contact microwave
Output	Open collector signals are evaluated by FTR325 switch amplifier. Alarm and control devices may be connected to the FTR325 relay outputs.
Measured detection range	Up to 26 ft Up to 66 ft
Power supply	Powered by FTR325 switch amplifier
Ambient temperature	-4 to +158°F
Process temperature	-4 to +158°F
Process pressure	11 to 70 psi (only when the FQR50 or FDR50 are built into the process)
Process connections	Threaded: 1½" NPT, aluminum or 316Ti SS
Housing	Aluminum or 316 Ti SS
Approvals/Certificates	CE





Nivotester FTR325 Switch Amplifier	
	FTR325 Single channel amplifier 
Application	Single channel switch amplifier for the Soliwave microwave barrier system. Used for level detection of solids or control and counting of packaged goods
Input	Open collector output from Soliwave
Output	SPDT relay and SPST alarm signal output relay
Power supply	85 to 253 VAC, 50/60 Hz 20 to 60 VDC / 20 to 30 VAC, 50/60 Hz
Ambient temperature	-4 to +140°F
Mounting	DIN rail
Housing	Polycarbonate
Approvals/Certificates	CE

Solimotion Flow Indicator	
	FTR20 
Application	Flow indicator, bulk solids
Measurement type	Microwave barrier
Output	Relay SPST Analog 4 to 20 mA Solid State relay
Measured detection range	65 ft (20 m)
Power supply	85 - 253 VAC or 20 - 60 VDC Solid State 30 VAC or 30 VDC
Ambient temperature	-40 to +158°F
Process temperature	-40 to +158°F
Process pressure	7.2 to 98.6 psia
Process connections	Thread R 1½" (EN 10226) NPT 1½" (ANSI/ASME B1.20.1)
Housing	Polyester or Stainless Steel
Approvals/Certificates	ATEX, IECEX

Mechanical





Soliswitch	
	FTE31 
Application	Solids
Measurement type	Paddle switch
Output	Binary, SPDT relay
Measured detection range	FTE rod: 4" to 23" FTE cable: up to 78"
Power supply	110 VAC 230 VAC 20 to 28 VDC
Ambient temperature	-4 to +140°F
Process temperature	-4 to +180°F
Process pressure	7 to 26 psi
Maximum particle size	2"
Process connections	Threaded: 1¼" NPT Valox 553 (PBT) or 316L SS
Wetted material	Rod and paddle: 316L SS Cable extensions: 316Ti SS
Function indication	N/A
Housing	PBT
Approvals/Certificates	CE, FM, CSA



Ultrasonic



Prosonic M					
	FMU 40	FMU 41	FMU 42	FMU 43	FMU 44
					
Application	Solids, liquids	Solids, liquids	Solids, liquids	Solids, liquids	Solids, liquids
Measurement type	Ultrasonic, continuous, non-contact	Ultrasonic, continuous, non-contact	Ultrasonic, continuous, non-contact	Ultrasonic, continuous, non-contact	Ultrasonic, continuous, non-contact
Maximum measured range	Solids: 6 ft Liquids: 16 ft	Solids: 12 ft Liquids: 26 ft	Solids: 16 ft Liquids: 33 ft	Solids: 23 ft Liquids: 50 ft	Solids: 33 ft Liquids: 65 ft
Output	4 to 20 mA, HART, Profibus, Foundation Fieldbus	4 to 20 mA, HART, Profibus, Foundation Fieldbus	4 to 20 mA, HART, Profibus, Foundation Fieldbus	4 to 20 mA, HART, Profibus, Foundation Fieldbus	4 to 20 mA, HART, Profibus, Foundation Fieldbus
Power supply	HART 2-wire, 4-20 mA loop HART 4-wire, 10.5 to 32 VDC HART 4-wire, 90 to 253 VAC 2-wire Profibus 2-wire Foundation Fieldbus	HART 2-wire, 4-20 mA loop HART 4-wire, 10.5 to 32 VDC HART 4-wire, 90 to 250 VAC 2-wire Profibus 2-wire Foundation Fieldbus	HART 2-wire, 4-20 mA loop HART 4-wire, 10.5 to 32 VDC HART 4-wire, 90 to 250 VAC 2-wire Profibus 2-wire Foundation Fieldbus	HART 4-wire, 10.5 to 32 VDC HART 4-wire, 90 to 250 VAC 2-wire Profibus 2-wire Foundation Fieldbus	HART 2-wire, 4-20 mA HART 4-wire, 10.5 to 32 VDC HART 4-wire, 90 to 250 VAC 2-wire Profibus 2-wire Foundation Fieldbus
Ambient temperature	-40 to +176°F	-40 to +176°F	-40 to +176°F	-40 to +176°F	-40 to +176°F
Process temperature	-40 to +176°F	-40 to +176°F	-40 to +176°F	-40 to +176°F	-40 to +176°F
Process pressure	10 to 44 psi	10 to 44 psi	10 to 36 psi	10 to 36 psi	10 to 36 psi
Grain size	Min. 0.16"	Min. 0.16"	Min. 0.16"	Min. 0.16"	Min. 0.16"
Process connections	1-1/2" NPT	2" NPT	3" or 4" universal flange FAU 20 mounting bracket	4" universal with slip-on flange	4" or 6" universal flange, 8" ANSI FAU 20 mounting bracket
Wetted material	PVDF	PVDF	PVDF	UP and 316 Ti SS	PP, PVDF and 316L SS
Operation	HART, VU 331 display module, ToF Tool software	HART, VU 331 display module, ToF Tool software	HART, VU 331 display module, ToF Tool software	HART, VU 331 display module, ToF Tool software	HART, VU 331 display module, ToF Tool software
Housing	Aluminum, Aluminum with separate connection compartment	Aluminum, Aluminum with separate connection compartment	Aluminum, Aluminum with separate connection compartment	Aluminum	Aluminum, Aluminum with separate connection compartment
Approvals / certificates	CE, FM, CSA	CE, FM, CSA	CE, FM, CSA	CE, FM, CSA	CE, FM, CSA

Prosonic T	
	FMU30
	
Application	Liquids, pastes, coarse bulk solids
Measurement type	Ultrasonic, continuous, non-contact for level, flow, or volume
Maximum measured range	1-1/2" sensor: Liquids, 16 ft; solids 6 ft 2" sensor: Liquids 26 ft; solids 11 ft
Output	4 to 20 mA
Power supply	14 to 35 VDC
Ambient temperature	-4 to +140°F
Process temperature	-4 to +140°F
Process pressure	10 to 43 psi
Process connections	1-1/2" NPT or 2" NPT UNI flange: 2", 3", 4"
Wetted material	Sensor, PP; matching layer, EPDM
Operation	LCD display, 3 pushbuttons
Housing	PBT
Approvals / certificates	CE, CSA general purpose





NOTE:
FMU30 replaces the FTU230
and FTU231

Prosonic S Sensors (for Prosonic S Transmitter)				
	FDU 90	FDU 91	FDU 91 F	FDU 92
				
Application	Liquids, solids	Liquids, solids	Liquids, solids, hygienic	Liquids, solids
Measurement type	Ultrasonic, continuous, non-contact	Ultrasonic, continuous, non-contact	Ultrasonic, continuous, non-contact	Ultrasonic, continuous, non-contact
Measured range	Liquids: 10 ft Solids: 4 ft	Liquids: 33 ft Solids: 16 ft	Liquids: 33 ft Solids: 16 ft	Liquids: 65 ft Solids: 33 ft
Output	Analog signal to transmitter	Analog signal to transmitter	Analog signal to transmitter	Analog signal to transmitter
Power supply	FMU 90 Prosonic transmitter	FMU 90 Prosonic transmitter	FMU 90 Prosonic transmitter	FMU 90 Prosonic transmitter
Process temperature	-40 to +176°F	-40 to +176°F	-40 to +221°F (up to 275°F for 30 min)	-40 to +203°F
Process pressure	10 to 58 psi	10 to 58 psi	10 to 58 psi	10 to 58 psi
Process connections	1" NPT	1" NPT	1" NPT, slip-on flange, Tri-clamp	1" NPT
Housing / wetted material	PVDF	PVDF	316L SS	PVDF
Ingress protection	NEMA 6P	NEMA 6P	NEMA 6P	NEMA 6P
Approvals / certificates	CE, FM, CSA	CE, FM, CSA	CE, FM, CSA, 3-A	CE, FM, CSA

Prosonic S Sensors (for Prosonic S Transmitter), continued			
	FDU 93	FDU 95	FDU 96
			
Application	Liquids, solids	Solids	Solids
Measurement type	Ultrasonic, continuous, non-contact	Ultrasonic, continuous, non-contact	Ultrasonic, continuous, non-contact
Measured range	Liquids: 82 ft, solids: 50 ft	Solids: 148 ft	Solids: 230 ft
Output	Analog signal to transmitter	Analog signal to transmitter	Analog signal to transmitter
Power supply	FMU 90 Prosonic transmitter	FMU 90 Prosonic transmitter	FMU 90 Prosonic transmitter
Process temperature	-40 to +203°F	-40 to +176°F (optional to 302°F)	-40 to +302°F
Process pressure	10 to 43 psi	10 to 22 psi	10 to 43 psi
Process connections	1" NPT	1" NPT	1" NPT
Housing / wetted material	UP, Al/PTFE	UP/PE (optional UP/VA)	UP / Aluminum (PTFE coated)
Ingress protection	NEMA 6P	NEMA 6P	NEMA 6P
Approvals / certificates	CE, FM, CSA	CE, FM, CSA	CE, FM, CSA

Prosonic S Transmitter		
	FMU 90	FMU 95
		
Application	Level, flow, pump control, liquids or solids	Level control for silo or tank farms
Measurement type	Ultrasonic, continuous, non-contact	Ultrasonic, continuous, non-contact
Measured range	Dependent on FDU sensor (see sensors above)	Dependent on FDU sensor (see sensors above)
Input	From 1 or 2 FDU 90 series sensors	Up to 5 or 10 FDU 90 series sensors
Output	0/4 to 20 mA, HART, Profibus DP, up to 3 totalizers and up to 3 resettable counters. Up to 6 SPDT relays	Profibus DP
Power supply	90 to 253 VAC, 50/60 Hz 10.5 to 32 VDC	90 to 253 VAC, 50/60 Hz 10.5 to 32 VDC
Ambient temperature	-40 to +140°F	-40 to +140°F
Mounting	Wall mount field enclosure, panel mount, 19" rack mount	Wall mount field enclosure, panel mount, 19" rack mount
Housing	Field housing, PC; DIN rail housing, PBT	Field housing, PC; DIN rail housing, PBT
Operation	HART, Profibus-DP 6-line plain text LCD, 3 push button keys, indicator LEDs	Profibus-DP, or FieldCare programming 6-line plain text LCD, 3 push button keys, indicator LEDs
Approvals / certificates	CE, CSA general purpose	CE, CSA general purpose

Radiometric

Radiometric source container				
	FQG60 	FQG61 / FQG62 	FQG63 	QG2000 
Application	Solids, Liquids, Suspensions, Sludge	Solids, liquids, suspensions, sludge	Solids, Liquids, Suspensions, Sludge	Solids, liquids, suspensions, sludge
Measurement Type	Non-contact radioactive measurement for continuous level, limit or density	Non-contact radioactive measurement for continuous level, limit or density	Non-contact radioactive measurement for continuous level, limit or density	Non-contact radioactive measurement for continuous level, limit or density
Radiation angle of emission	20° or 40°	5°, 20° or 40°		20° or 40°
Width of emission channel	6°	6°		6°
Shield Material	Lead	Lead	Lead	Lead
Source Material	¹³⁷ Cs or ⁶⁰ Co	¹³⁷ Cs or ⁶⁰ Co	¹³⁷ Cs or ⁶⁰ Co	¹³⁷ Cs or ⁶⁰ Co
Container Weight	39.69 lbs	FQG61 manual: 88 lbs pneumatic: 110 lbs FQG62 manual: 192 lbs pneumatic: 215 lbs	194 lbs	695 lbs
Ambient temperature	-40°F to +248°F	-40°F to +392°F -4°F to +176°F with pneumatic actuator	-62°F to +392°F	-4°F to +392°F
Mounting	Mounting kit	Flange, 150 lb ANSI, 4" steel or stainless steel	Flange, 150 lb ANSI, 4"	Steel or stainless steel mounting plate
Housing	316L	Steel, 304 SS, optional 316Ti SS	316L	316Ti SS
ON / OFF switching	Manual, padlock for security	Manual, padlock for security Pneumatic, padlock for security	Manual, padlock for security	Manual, padlock for security
Approvals / certificates	CE, FM, CSA, SIL2/3 (for level limit)	PTB report, CNSC, NRC	CE, FM, CSA, SIL2/3 (for level limit)	PTB report, CNSC

Radiometric measurement transmitter	
	<p>Gammapiot M FMG60</p> 
Application	Solids, liquids, suspensions, sludge
Measurement type	Non-contact radioactive measurement for continuous level, limit, density, concentration
Measured range	Up to 6.6 ft (single FMG60). Multiple units can be cascaded for longer ranges
Output	4 to 20 mA with HART®, Profibus®-PA, FOUNDATION™ Fieldbus, and pulses for cascading mode
Power supply	90 to 253 VAC, 50/60 Hz; 18 to 36 VDC
Ambient temperature	-40 to +140°F (up to 248°F with water cooling)
Mounting	FHG60 mounting kit
Housing	Terminal head, aluminum or 316L SS; detector pipe, 316L SS
Weight	24 up to 68 lbs; with water jacket, 44 up to 159 lbs
Approvals / certificates	CE, FM, CSA, SIL 2/3 (for level limit)







Radiometric measurement sensor and transmitter	
	<p>Gammapiot M FTG20</p> 
Application	Solids, Liquids, Suspensions, Sludge
Measurement type	Non-contact radioactive measurement for limit or density
Output	Relay, 8/16 mA (passive) or 4 to 20 mA output
Power supply	11 to 36 VDC, 11 to 30 VDC (Ex ia), 19 to 55 VDC or 19 to 253 VAC (50 to 60 Hz)
Ambient temperature	-40 to +158°F (-40 to +70°C) Aluminum housing, -40 to +158°F (-40 to +70°C) 316L housing, 32 to +248 °F (0 to +120°C) with 316L and water cooling
Mounting	Mounting Set
Weight	17 lbs
Approvals / certificates	CE, FM, CSA, SIL2/3 (for level limit)

Gamma modulator	
	<p>FHG65</p> 
Application	Suppresses background and extraneous radiation from the FMG60 Gammapiot
Power supply	18 to 36 VDC
Ambient temperature	-4 to +140°F without water cooling, 32 to 248°F with water cooling, at the terminal housing, maximum 167°F
Mounting	Mounted to source container FQG61 or FQG62
Housing	304SS Water jacket, 316L SS and 304 SS
Weight	Without water jacket, 40 lbs With empty water jacket, 46 lbs With water jacket full, 55 lbs
Approvals / certificates	CE, FM, CSA

Synchronizer	
	<p>FHG66</p> 
Application	Used to synchronize two or three FHG65 modulators
Output	Floating changeover contact
Function indication	LEDs indicate operation, faults and error assignment
Power supply	18 to 36 VDC
Ambient temperature	-4 to +140°F
Mounting	DIN rail
Housing	Polycarbonate
Weight	0.3 lbs
Approvals / certificates	CE

Flow Products available from Endress+Hauser

Electromagnetic

Sensors		Diameter	Measuring range	Pressure	Temperature (process)	
Electromagnetic (EMF) Proline	Promag D Water/Waste water		1 to 4"	0 to 33 ft/s 0 to 2642 gal/min	Cl 150 PN 16 JIS 10K	0 to +140°F
	Promag L Water/Waste water		2 to 90"	0 to 33 ft/s 0 to 713,265 gal/min	Cl 150 PN 10 to 16 AS Table E, PN 16	-4 to +194°F
	Promag W Water/Waste water		1 to 78"	0 to 33 ft/s 0 to 484,315 gal/min	Cl 150 to 300, PN 6 to 40 JIS 10 to 20K, AWWA Class D AS Table E, PN 16	-4 to +176°F
	Promag P Chemical/Process applications		½ to 24"	0 to 33 ft/s 0 to 42,267 gal/min	Cl 150 to 300, PN 10 to 40 JIS 10 to 20K AS Table E, PN 16	-40 to +356°F
	Promag H Hygiene		½ to 6"	0 to 33 ft/s 0 to 1242 gal/min	Cl 150, PN 16 to 40 JIS 10 to 20K	-4 to +302°F
	Promag S Inhomogeneous fluids High solid content		½ to 24"	0 to 33 ft/s 0 to 42,267 gal/min	Cl 150 to 300, PN 10 to 40 JIS 10 to 20K AS Table E, PN 16	-40 to +356°F

Transmitters	Combinable with	Housing	Display/Operation	Temperature (Ambient)	Power supply
10 Basic	Sensor D, L, W, P, H	Compact Alu Remote Alu	Two-line LCD/Push buttons Operation via FieldCare®	-4 to +140°F	AC 85 to 250 V (45 to 65 Hz) AC 20 to 28 V (45 to 65 Hz) DC 11 to 40 V
50 Standard	Sensor D, L, W, P, H	Compact SS Compact Alu Remote Alu	Two-line, backlit LCD/Push buttons Operation via FieldCare®	-4 to +140°F Optional: -40 to +140°F	AC 85 to 260 V (45 to 65 Hz) AC 20 to 55 V (45 to 65 Hz) DC 16 to 62 V
51 Custody transfer	Sensor W, P	Compact Alu Remote Alu	Two-line, backlit LCD/Push buttons Operation via FieldCare®	-4 to +140°F	AC 85 to 260 V (45 to 65 Hz) AC 20 to 55 V (45 to 65 Hz) DC 16 to 62 V
53 High-end	Sensor W, P, H	Compact SS Compact Alu Remote Alu	Four-line, backlit LCD/Touch control Operation via FieldCare	-4 to +140°F Optional: -40 to +140°F	AC 85 to 260 V (45 to 65 Hz) AC 20 to 55 V (45 to 65 Hz) DC 16 to 62 V
55 Special applications	Sensor S, H	Compact SS Compact Alu Remote Alu	Four-line, backlit LCD/Touch control Operation via FieldCare®	-4 to +122°F Optional: -40 to +122°F	AC 20 to 260 V (45 to 65 Hz) DC 20 to 64 V
100 Compact design	Sensor P, H	Compact Alu Compact SS	No Display Operation via webbrowser, FieldCare® or HART®	-40 to +140°F	DC 20 to 30 V
200 Two-wire	Sensor P, H	Compact Alu	Four-line LCD/Push buttons or Touch control Operation via FieldCare®	-40 to +140°F	Two-wire DC 18 to 30 V
400 Water Waste water	Sensor D, L, W	Compact/Remote Polycarbonate	Four-line, backlit LCD/Touch control Operation via FieldCare® or webbrowser	-4 to +122°F	AC 90 to 264 V (47 to 63 Hz) AC 18 to 30 V (44 to 66 Hz) DC 18 to 30 V
800 Battery-powered	Sensor L, W	Compact/Remote Polycarbonate	Eight-line LCD/Push buttons Operation via Config 5800 or GSM and GPSR	-4 to +140°F	Battery operation: DC 3.6 V Mains: AC 100 to 240 V (44 to 66 Hz), DC 12 to 60 V

Materials (wetted parts)	Process connection	Protection	Approval/Certification	Measuring uncertainty ¹⁾ (best possible "accuracy")
Polyamid liner	Wafer: EN (DIN), ASME, JIS	NEMA 4X (IP67)	Drinking water	Liquids: ±0.5%
Polyurethane liner PTFE liner Hard rubber liner	Lap-joint flange (DN ≤ 300): EN (DIN), ASME; Welded flange (DN ≥ 350): EN (DIN), ASME, AWWA, AS	NEMA 4X/6P (IP67/IP68)	Drinking water; custody transfer	Liquids: ±0.2%
Hard rubber liner Polyurethane liner	Flange: EN (DIN), ASME, JIS, AWWA, AS	NEMA 4X/6P (IP67/IP68)	Drinking water; custody transfer; marine approvals; PED, CRN; certified corrosion resistance (EN ISO 12944)	Liquids: ±0.2%
PFA liner PTFE liner	Flange: EN (DIN), ASME, JIS, AS	NEMA 4X/6P (IP67/IP68)	Drinking water; custody transfer; marine approvals; PED, CRN	Liquids: ±0.2%
PFA liner	Flange: EN (DIN), ASME, JIS; external thread, internal thread, weld connection, clamp connection, couplings	NEMA 4X (IP67)	3-A, EHEDG, FDA; marine approvals; PED, CRN	Liquids: ±0.2%
PTFE, PFA, Polyurethane liner Natural rubber liner Hard rubber liner	Flange: EN (DIN), ASME, JIS, AS	NEMA 4X/6P (IP67/IP68)	PED, CRN	Liquids: ±0.2%

Galvanic isolation	Inputs	Outputs	Communication	Ex approvals	Protection
Inputs/Outputs/ Power supply	–	4–20 mA, pulse/switch output	HART®	FM, CSA Div. 2	NEMA 4X (IP67)
Inputs/Outputs/ Power supply	Status input	0/4–20 mA, pulse/frequency (1 kHz passive), switch output	HART®, PROFIBUS® DP, PROFIBUS® PA	ATEX, IECEx, FM, CSA, TIIS, NEPSI	NEMA 4X (IP67)
Inputs/Outputs/ Power supply	Status input	0/4–20 mA, pulse/frequency (1 kHz passive), switch output	HART®	ATEX, IECEx	NEMA 4X (IP67)
Inputs/Outputs/ Power supply	Status input, current input 4–20 mA	0/4–20 mA, status (10 kHz, active/passive), relays, switch output	HART®, PROFIBUS® DP/PA, FOUNDATION™ Fieldbus, Modbus RS485, EtherNet/IP™	ATEX, IECEx, FM, CSA, TIIS, NEPSI	NEMA 4X (IP67)
Inputs/Outputs/ Power supply	Status input, current input 4–20 mA	0/4–20 mA, pulse/frequency (10 kHz, active/passive), relays, switch output	HART®, PROFIBUS DP, PROFIBUS PA FOUNDATION™ Fieldbus	FM, CSA Div. 2, IECEx Zone 2	NEMA 4X (IP67)
Inputs/Outputs/ Power supply	–	4–20 mA, pulse/frequency/switch output	HART®, PROFIBUS® DP, Modbus RS485, EtherNet/IP™	ATEX, IECEx, cCSAus	NEMA 4X (IP66 and IP67) Optional: IP69K (exceeds NEMA 4X PW12)
Inputs/Outputs	–	4–20 mA, pulse/frequency/switch output	HART®	ATEX, IECEx, cCSAus	NEMA 4X (IP66 and IP67)
Inputs/Outputs/ Power supply	Status input	0/4–20 mA, pulse/frequency/switch output	HART®, integrated webserver and service interface via RJ45 Ethernet In preparation: EtherNet/IP, PROFIBUS® DP	cCSAus (Cl. I Div. 2)	NEMA 4X (IP66 and IP67)
Inputs/Outputs/ Power supply	Status input	Pulse/switch output	4-band GSM/GPRS modem for data transmission via e-mail or SMS	–	NEMA 4X (IP67)

¹⁾ Depending on the transmitter

Coriolis

Sensors

		Diameter	Measuring range	Pressure	Temperature (process)
Coriolis Proline	Promass F Universal flowmeter		3/8 to 10" HT: 1", 2", 3"	0 to 80,840 lb/min	CI 150 to 600 PN 16 to 100 JIS 10 to 63K -58 to +392°F HT: -58 to +662°F
	Promass A Low flow rates		1/24 to 1/8"	0 to 16.5 lb/min	CI 150 to 600 PN 16 to 400 JIS 10 to 63K -58 to +392°F
	Promass I Hygiene, viscosity		3/8 to 3"	0 to 6600 lb/min	CI 150 to 600 PN 40 to 100 JIS 10 to 63K -58 to +302°F
	Promass H Chemically aggressive fluids		3/8 to 2"	0 to 2570 lb/min	CI 150 to 300 PN 40 JIS 10 to 20K -58 to +392°F (Zr) -58 to +302°F (Ta)
	Promass E Basic applications		3/8 to 3"	0 to 6600 lb/min	CI 150 to 600 PN 40 to 100 JIS 10 to 63K -40 to +284°F
	Promass S Food & Beverages		3/8 to 2"	0 to 2570 lb/min	CI 150 to 300 PN 40 to 63 JIS 10 to 40K -58 to +302°F
	Promass P Life Sciences Industries (Pharma, biotechnology)		3/8 to 2"	0 to 2570 lb/min	CI 150 to 300 PN 40 to 63 JIS 20 to 40K -58 to +392°F
	Promass O High pressures Oil and gas industry		3 to 6"	0 to 29,395 lb/min	CI 900, CI 1500 PN 160, PN 250 -40 to +392°F
	Promass X High flow rates Oil and gas industry		12 to 16"	0 to 150,649 lb/min	CI 150 to 600 PN 10 to 100 -58 to +356°F
	Cubemass Low flow rates		1/24", 1/12", 1/8", 1/4"	0 to 37 lb/min	2320/5800 psig -58 to +392°F
	Cubemass DCI Low flow rates		1/24", 1/12", 1/8", 1/4"	0 to 37 lb/min	2320/5800 psig -58 to +392°F

Transmitters

	Combinable with	Housing	Display/Operation	Temperature (Ambient)	Power supply
40 Basic	Sensor E	Compact Alu	Two-line, backlit LCD Operation via HART® or FieldCare®	-4 to +140°F Optional: -40 to +140°F	AC 85 to 260 V (45 to 65 Hz) AC 20 to 55 V (45 to 65 Hz) DC 16 to 62 V
80 Standard	Sensor F, A, I, H, E, S, P	Compact SS Compact Alu Remote Alu	Two-line, backlit LCD/Push buttons Operation via FieldCare®	-4 to +140°F Optional: -40 to +140°F	AC 85 to 260 V (45 to 65 Hz) AC 20 to 55 V (45 to 65 Hz) DC 16 to 62 V
83 High-end	Sensor F, A, I, H, E, S, P, O, X	Compact SS Compact Alu Remote Alu	Four-line, backlit LCD/ Touch Control Operation via FieldCare®	-4 to +140°F Optional: -40 to +140°F	AC 85 to 260 V (45 to 65 Hz) AC 20 to 55 V (45 to 65 Hz) DC 16 to 62 V
84 Custody transfer	Sensor F, A, O, X, Cubemass DCI	Compact SS Compact Alu Remote Alu	Four-line, backlit LCD/ Touch Control Operation via FieldCare®	-4 to +140°F Optional: -40 to +140°F	AC 85 to 260 V (45 to 65 Hz) AC 20 to 55 V (45 to 65 Hz) DC 16 to 62 V
100 Compact design	Sensor F, I, E, S, P, Cubemass	Compact SS Compact Alu Ultra compact SS	No Display Operation via webbrowser, FieldCare® or HART®	-40 to +140°F	DC 20 to 30 V
200 Two-wire	Sensor E, F	Compact Alu Compact SS	Four-line LCD/Push buttons or Touch control Operation via FieldCare®	-4 to +140°F	Two-wire DC 18 to 30 V







Materials (wetted parts)	Process connection	Protection	Approval/Certification	Measuring uncertainty ¹⁾ (best possible „accuracy“)
Measuring tube: 904L (1.4539), 316/316L (1.4404), Alloy C-22 (2.4602); Connection: 316/316L (1.4404), Alloy C-22 (2.4602)	Flange: EN (DIN), ASME, JIS Tri-Clamp, couplings, VCO	NEMA 4X (IP67)	SIL 2/3; 3-A, EHEDG; PED, CRN, AD 2000; marine approvals	Liquids: ±0.10% (±0.05% PremiumCal) Gases: ±0.35%
Measuring tube: 904L (1.4539), Alloy C-22 (2.4602); Connection: 904L (1.4539), Alloy C-22 (2.4602), 316/316L (1.4404)	Tri-Clamp, VCO	NEMA 4X (IP67)	SIL 2; 3-A, EHEDG; PED, CRN	Liquids: ±0.10% Gases: ±0.50%
Measuring tube: Titanium grade 9 Connection: Titanium grade 2	Flange: EN (DIN), ASME, JIS Tri-Clamp, couplings	NEMA 4X (IP67)	SIL 2; 3-A, EHEDG; PED, CRN	Liquids: ±0.10% Gases: ±0.50%
Measuring tube: Zirconium 702/R 60702, Tantalum 2.5W; Connection: Tantalum, Zirconium 702/R 60702	Flange: EN (DIN), ASME, JIS	NEMA 4X (IP67)	SIL 2; PED, CRN	Liquids: ±0.10% Gases: ±0.50%
Measuring tube: 904L (1.4539) Connection: 316/316L (1.4404)	Flange: EN (DIN), ASME, JIS Tri-Clamp, couplings, VCO	NEMA 4X (IP67)	SIL 2; 3-A; PED, CRN; marine approvals	Liquids: ±0.15% (Optional: ±0.10%) Gases: ±0.75%
Measuring tube: 904L (1.4539) Connection: 316L (1.4435), 316/316L (1.4404)	Flange: EN (DIN), ASME, JIS Tri-Clamp, couplings	NEMA 4X (IP67)	SIL 2; 3-A, EHEDG, FDA; PED, CRN	Liquids: ±0.10% Gases: ±0.50%
Measuring tube: 316L (1.4435) Connection: 316L (1.4435), 316/316L (1.4404)	Flange: EN (DIN), ASME, JIS Hygienic clamps, couplings and flanges	NEMA 4X (IP67)	3-A, EHEDG, FDA; ASME BPE, ISPE; SIL 2; PED, CRN	Liquids: ±0.10% Gases: ±0.50%
Measuring tube: 25Cr duplex (1.4410) Connection: 25Cr duplex (1.4410)	Flange: EN (DIN), ASME	NEMA 4X (IP67)	Custody transfer; SIL 2; PED, CRN, AD 2000; Materials conforms to NORSOK M-630, NACE MR175/MR103	Liquids: ±0.10% (±0.05% PremiumCal) Gases: ±0.35%
Measuring tube: 316/316L (1.4404) Connection: 316/316L (1.4404)	Flange: EN (DIN), ASME	NEMA 4X (IP67)	Custody transfer; marine approvals; PED, CRN; Materials conforms to NORSOK M-630, NACE MR175/MR103	Liquids: ±0.10% (±0.05% PremiumCal) Gases: ±0.35%
Measuring tube: 904L (1.4539) Connection: 904L (1.4539), 316/316L (1.4404)	VCO	NEMA 4X (IP67)	SIL 2; PED, CRN	±0.1%
Measuring tube: 904L (1.4539) Connection: 904L (1.4539), 316/316L (1.4404)	VCO	NEMA 4X (IP67)	SIL 2; PED, CRN	±0.1%

Galvanic isolation	Inputs	Outputs	Communication	Ex approvals	Protection
Inputs/Outputs/ Power supply	Status input	0/4–20 mA, frequency/switch output	HART®	ATEX, IECEx, FM, CSA, TIIS, NEPSI	NEMA 4X (IP67)
Inputs/Outputs/ Power supply	Status input	0/4–20 mA, pulse/frequency (1 kHz passive), switch output	HART®, PROFIBUS® PA	ATEX, IECEx, FM, CSA, TIIS, NEPSI	NEMA 4X (IP67)
Inputs/Outputs/ Power supply	Status input, current input 4–20 mA	0/4–20 mA, pulse/frequency (10 kHz, active/passive), relays, switch output	HART®, PROFIBUS® DP/PA, FOUNDATION™ Fieldbus, Modbus RS485, EtherNet/IP™	ATEX, IECEx, FM, CSA, TIIS, NEPSI	NEMA 4X (IP67)
Inputs/Outputs/ Power supply	Status input	0/4–20 mA, pulse/frequency (10 kHz, active/passive), 2 × pulse (90°/180°), relays, switch output	HART® Modbus RS485	ATEX, IECEx, FM, CSA, TIIS, NEPSI	NEMA 4X (IP67)
Inputs/Outputs/ Power supply	–	4–20 mA, pulse/frequency/ switch output	HART®, Modbus RS485, EtherNet/IP™	ATEX, IECEx, cCSAus (Modbus only)	NEMA 4X (IP66 and IP67) Optional: IP69K (exceeds NEMA 4X PW12)
Inputs/Outputs	–	4–20 mA, pulse/frequency/ switch output	HART®, PROFIBUS® PA	ATEX, IECEx, cCSAus	NEMA 4X (IP66 and IP67)

¹⁾ Depending on the transmitter

Ultrasonic

Sensors

		Diameter	Measuring range	Pressure	Temperature (process)
Ultrasonic Proline	Prosonic Flow W Clamp-on sensor Standard applications	 ½ to 160"	0 to 50 ft/s 0 to 2,987,656 gal/min	No limit Non-invasive	-4 to +176°F Optional: 32 to 266°F
	Prosonic Flow W Insertion sensor Standard applications	 8 to 160"	0 to 50 ft/s 0 to 2,987,656 gal/min	232 psig	-4 to +176°F
	Prosonic Flow P Clamp-on sensor Process applications	 ½ to 160"	0 to 50 ft/s 0 to 2,987,656 gal/min	No limit Non-invasive	-40 to +176°F Optional: 32 to 338°F
	Prosonic Flow F Inline sensor Chemical industry	 1 to 12"	0 to 33 ft/s 0 to 10,567 gal/min	CI 300 PN 40	-40 to +302°F Optional: -40 to +392°F
	Prosonic Flow B Methane/Biogas measurement	 2 to 8"	0 to 98 ft/s	145 psia	32 to 176°F
	Prosonic Flow C Inline sensor Water/Waste water	 12 to 78"	0 to 33 ft/sec 0 to 484,315 gal/min	CI 150 PN 16	-4 to +140°F

Transmitters



	Combinable with	Housing	Display/Operation	Temperature (Ambient)	Power supply
91 Basic	Sensor W	Remote Alu	Two-line LCD/Push buttons Operation via FieldCare	-4 to +140°F	AC 85 to 250 V (45 to 65 Hz) AC 20 to 28 V (45 to 65 Hz) DC 11 to 40 V
93 High-end	Sensor W, P, C	Remote Alu	Four-line, backlit LCD/Touch control Operation via FieldCare	-4 to +140°F Optional: -40 to +140°F	AC 85 to 260 V (45 to 65 Hz) AC 20 to 55 V (45 to 65 Hz) DC 16 to 62 V
93 T Portable	Sensor P	Portable Plastic	Four-line, backlit LCD/Touch control Operation via FieldCare	0 to +140°F	Rechargeable battery + charger: AC 100 to 240 V (47 to 63 Hz)
92 Inline	Sensor F	Compact Alu Remote Alu	Two-line LCD/Push buttons Operation via FieldCare	Compact: -40 to +140°F Remote: -40 to +176°F	Two-wire DC 12 to 35 V

Materials (wetted parts)	Process connection	Protection	Approval/Certification	Measuring uncertainty ¹⁾ (best possible „accuracy“)
Not wetted (Clamp-on sensor)	Clamp-on sensor	NEMA 4X/6P (IP67/IP68)	Marine approvals	Liquids: <2.0% (onsite) ±0.5% (under reference conditions)
316L (1.4404)	Welding connector	NEMA 6P (IP68)	–	Liquids: <2.0% (onsite) ±0.5% (under reference conditions)
Not wetted (Clamp-on sensor)	Clamp-on sensor	NEMA 4X/6P (IP67/IP68)	Marine approvals	Liquids: <2.0% (onsite) ±0.5% (under reference conditions)
CF3M/316/316L A105/A106/316/316L	Flange: EN (DIN), ASME, JIS	NEMA 4X/6P (IP67/IP68)	Marine approvals; PED, CRN, AD 2000; NACE MR175/MR103	Liquids: ±0.5% (2 or 3 beams) ±0.3% (4 beams)
316L (1.4404)	Flange: EN (DIN), ASME	NEMA 4X (IP66/67)	PED	Gases: ±1.5% Methane content: ±2.0% o.f.s
Carbon steel, epoxy coated	Flange: EN (DIN), ASME, AWWA	NEMA 6P (IP68)	Drinking water	Liquids: ±0.5%

Galvanic isolation	Inputs	Outputs	Communication	Ex approvals	Protection
Inputs/Outputs/ Power supply	–	0/4–20 mA, pulse/switch output	HART	FM, CSA Div. 2	NEMA 4X (IP67)
Inputs/Outputs/ Power supply	Status input, current input 4–20 mA	0/4–20 mA, pulse/frequency (10 kHz, active/passive), relays, switch output	HART, PROFIBUS DP, PROFIBUS PA, FOUNDATION Fieldbus	ATEX, IECEx, FM, CSA, TIIS, NEPSI	NEMA 4X (IP67)
Inputs/Outputs/ Power supply	Current input 4–20 mA	Data logger	–	–	–
Inputs/Outputs	–	4–20 mA, pulse/switch output	HART, PFM, PROFIBUS PA, FOUNDATION Fieldbus	ATEX, IECEx, FM, CSA, TIIS, NEPSI	NEMA 4X (IP67)

Vortex

Sensors





			Diameter	Measuring range	Pressure	Temperature (process)
Vortex Proline	Prowirl F Flanged version		½ to 12"	Liquids: 42 to 10,390 gal/m Gases: 13.5 to 121,664 SCFM	Cl 150 to 1500 PN 10 to 250 JIS 10 to 40K	-328 to +752°F Optional: -328 to +842°F
	Prowirl W Wafer version		½ to 6"	Liquids: 0.83 to 2752 gal/m Gases: 18 to 32,177 SCFM	Cl 150 to 300 PN 10 to 40 JIS 10 to 20K	-328 to +752°F Optional: -328 to +842°F

Transmitters

	Combinable with	Housing	Display/Operation	Temperature (Ambient)	Power supply
72 Standard	Sensor F, W	Compact Alu Remote Alu	Two-line LCD/Push buttons Operation via FieldCare	Compact: -40 to +158°F Remote: -40 to +176°F	Two-wire: DC 12 to 36 V EEx i: DC 12 to 30 V EEx d: DC 15 to 36 V
73 With flow computer	Sensor F, W	Compact Alu Remote Alu	Two-line LCD/Push buttons Operation via FieldCare	Compact: -40 to +158°F Remote: -40 to +176°F	Two-wire: DC 12 to 36 V EEx i: DC 12 to 30 V EEx d: DC 15 to 36 V

Thermal

Sensors

			Diameter	Measuring range	Pressure	Temperature (process)
Thermal Proline	t-mass A Flanges/External threads Basic applications		½ to 2"	Gas and process condition dependent	-7.25 to 580 psig	-40 to +212°F
	t-mass B Insertion sensor Basic applications		3 to 60"	Gas and process condition dependent	-7.25 to 290 psig	-40 to +212°F
	t-mass F Flanged version High-End		½ to 4"	Gas and process condition dependent	Cl 150 to 300 PN 16 to 40	-40 to +212°F
	t-mass I Insertion sensor High-End		3 to 60"	Gas and process condition dependent	290 psi g	-40 to +266°F

Transmitters

	Combinable with	Housing	Display/Operation	Temperature (Ambient)	Power supply
150 Basic	Sensor A, B	Compact Alu	Four-line LCD/Push buttons Operation via FieldCare®, HART® or service interface (CDI)	-40 to +140°F	DC 18 to 30 V
65 High-end	Sensor I, F	Compact Alu Remote Alu Option: Compact SS	Two-line, backlit LCD/Push buttons Operation via FieldCare®	-4 to +140°F Optional: -40 to +140°F	AC 85 to 260 V (45 to 65 Hz) AC 20 to 55 V (45 to 65 Hz) DC 16 to 62 V

Materials (wetted parts)	Process connection	Protection	Approval/Certification	Measuring uncertainty ¹⁾ (best possible „accuracy“)
Meter body: CF3M (1.4404), Alloy C-22 (2.4602) DSC sensor: 316L (1.4435), Inconel 718, Alloy C-22(2.4602), Titanium Gr. 5	Flange: EN (DIN), ASME, JIS Optional: with integrated line size reduction	NEMA 4X (IP67)	Marine approvals; PED, CRN; SIL 1 (Prowirl 73), SIL 2 (Prowirl 72); degreased acc. to BS-IEC-60877:1999	Liquids: ±0.75% Vol. Gases/steam: ±1.0% Vol.
Meter body: CF3M (1.4404) DSC sensor: 316L (1.4435), Alloy C-22 (2.4602)	Wafer: EN (DIN), ASME, JIS	NEMA 4X (IP67)	Marine approvals; PED, CRN, AD 2000; SIL 1 (Prowirl 73), SIL 2 (Prowirl 72); degreased acc. to BS-IEC-60877:1999	Liquids: ±0.75% Vol., ±1% Mass Gases/steam: ±1.0% Vol., ±1.7% Mass





Galvanic isolation	Inputs	Outputs	Communication	Ex approvals	Protection
Inputs/Outputs	–	4–20 mA, pulse/switch output	HART®, PFM, PROFIBUS® PA, FOUNDATION™ Fieldbus	ATEX, IECEx, FM, CSA, TIIS, NEPSI	NEMA 4X (IP67)
Inputs/Outputs	Pressure, temperature, density using PROFIBUS® PA, HART®, FF	4–20 mA, pulse/switch output, frequency	HART®, PFM, PROFIBUS® PA, FOUNDATION™ Fieldbus	ATEX, IECEx, FM, CSA, TIIS, NEPSI	NEMA 4X (IP67)

Materials (wetted parts)	Process connection	Protection	Approval/Certification	Measuring uncertainty ¹⁾ (best possible „accuracy“)
316L (1.4404)	Lap-joint flange, flange: EN (DIN), ASME Rexternal thread (EN) NPExternal thread (ASME)	NEMA 4X (IP66 and IP67)	PED	Gases: ±3% o.r. (15 to 100% o.f.s.) ±0.45% o.f.s. (1 to 15% o.f.s.)
316L (1.4404)	Thread: G1A, G¾A 1" NPT, ¾" NPT	NEMA 4X (IP66 and IP67)	PED	Gases: ±3% o.r. (15 to 100% o.f.s.) ±0.45% o.f.s. (1 to 15% o.f.s.)
316L (1.4404) Alloy C-22	Flange: EN (DIN), ASME, JIS	NEMA 4X (IP67)	PED, CRN; degreased acc. to 0000-N-S-430-00-01 (BOC) and BS-IEC-60877:1999	Gases: ±1.5% o.r. (10 to 100% o.f.s.) ±0.15% o.f.s. (1 to 10% o.f.s.)
316L (1.4404) Alloy C-22	Thread: 1" NPT, G1A	NEMA 4X (IP67)	PED, CRN; degreased acc. to 0000-N-S-430-00-01 (BOC) and BS-IEC-60877:1999	Gases: ±1.5% o.r. (10 to 100% o.f.s.) ±0.15% o.f.s. (1 to 10% o.f.s.)

Galvanic isolation	Inputs	Outputs	Communication	Ex approvals	Protection
Outputs/ Power supply	–	0/4–20 mA, pulse/frequency/switch output	HART	cCSAus (Cl. I Div. 2)	NEMA 4X (IP66 and IP67)
Inputs/Outputs/ Power supply	Status input, current input 4–20 mA	0/4–20 mA, pulse/frequency, (1 kHz, active/passive), relays, switch output	HART®, PROFIBUS® DP/PA, Modbus RS485, FOUNDATION™ Fieldbus	ATEX, IECEx, FM, CSA, TIIS, NEPSI	NEMA 4X (IP67)

Flow measurement OEM

Sensors

			Diameter	Measuring range	Pressure	Temperature (process)
EMF	Dosimag Filling/bottling Conductive liquids		1/8", 3/8", 1/2"	0.033 to 33 ft/s 0 to 26.3 gpm	232 psi	-4 to +266°F
	Dosimass Filling/bottling Liquids		3/8", 1/2", 1"	0 to 660 lbs/min	580 psi	-40 to +257°F
Coriolis	CNGmass Compressed Natural Gas Fueling		3/8", 1/2", 1"	0 to 330 lb/min	max. 5080 psi	-58 to +257°F
	CNGmass DCI Compressed Natural Gas Fueling		3/8", 1/2", 1"	0 to 330 lb/min	max. 5080 psi	-58 to +302°F
	LPGmass Liquified Petroleum Gas Fueling		3/8", 1/2", 1", 1 1/2"	0 to 1650 lb/min	Cl 150 to 300 PN 40 JIS 10 to 63K	-40 to +257°F



Transmitters

	Housing	Display/Operation	Temperature (Ambient)	Power supply
Dosimag Compact version	Compact SS	Operation via FieldCare®	-4 to +140°F	DC 20 to 30 V
Dosimass Compact version	Compact SS	Operation via FieldCare®	-4 to +140°F	DC 20 to 30 V
CNGmass Compact version Custody transfer	Compact Alu	Operation via FieldCare®	-40 to +140°F	AC 20 to 28 V DC 10 to 30 V
CNGmass DCI Compact/remote version Custody transfer	Compact SS Compact Alu Remote Alu	Four-line, backlit LCD/Touch control Operation via FieldCare®	-40 to +140°F	AC 85 to 260 V (45 to 65 Hz) AC 20 to 55 V (45 to 65 Hz) DC 16 to 62 V
LPGmass Compact version Custody transfer	Compact Alu	Operation via FieldCare®	-40 to +140°F	AC 20 to 28 V DC 10 to 30 V

Materials (wetted parts)	Process connection	Protection	Approval/Certification	Measuring uncertainty ¹⁾ (best possible "accuracy")
PFA liner	Tri-Clamp®, weld connection	NEMA 4X (IP67)	3-A, EHEDG, FDA; PED, CRN	±0.5% Optional: ±0.25%
904L (1.4539) 316L (1.4404)	Tri-Clamp®, couplings	NEMA 4X (IP67)	3-A; PED, CRN	±0.15%
316L (1.4404) 316L (1.4435)	Internal thread: G½" (DN 8), G¾" (DN 15) G1" (DN 25)	NEMA 4X (IP67)	Custody transfer; PED, CRN	±0.5% (per fill cycle)
316L (1.4404) 316L (1.4435)	Internal thread: G½" (DN 8), G¾" (DN 15) G1" (DN 25)	NEMA 4X (IP67)	Custody transfer; PED, CRN	±0.5% (per fill cycle)
904L (1.4539) 316L (1.4404)	Flange: EN (DIN), ASME, JIS; VCO	NEMA 4X (IP67)	Suitable for system approval acc. to OIML R117-1 (2004/22/EG [MID], Appendix MI-005); PED	±0.2%

Galvanic isolation	Inputs	Outputs	Communication	Ex approvals	Protection
Inputs/Outputs/Power supply	–	Pulse, switch output	–	–	NEMA 4X (IP67)
Inputs/Outputs/Power supply	–	Pulse, switch output	–	ATEX II 3G	NEMA 4X (IP67)
Inputs/Outputs/Power supply	–	Pulse/frequency, switch output	Modbus RS485	ATEX, IECEx, FM, CSA, NEPSI	NEMA 4X (IP67)
Inputs/Outputs/Power supply	Status input	0/4–20 mA, pulse/frequency (10 kHz, active/passive), 2 × pulse (90°/180°), relays, switch output	HART®, Modbus RS485	ATEX, CEC, NEC, TIIS, NEPSI	NEMA 4X (IP67)
Inputs/Outputs/Power supply	–	Pulse/frequency, switch output	Modbus RS485	ATEX, IECEx, FM, CSA, NEPSI	NEMA 4X (IP67)

Flow monitoring



Sensors		Diameter	Measuring range	Pressure	Temperature (process)	
EMF	Magphant Limit switch/Trend display Conductive liquids		½ to 78"	0 to 248,982 gal/min	232 psia	-4 to +248°F
Thermal	Flowphant DTT31 Standard applications Liquids		ANSI NPT ¼ and ½"	0.1 to 9.84 ft/sec Relative value between 0 to 100%	Up to 1450 psi	-4 to +185°F
	Flowphant DTT35 Hygienic applications Liquids		Tri-Clamp® 1" - 1½", 2" Varivent® F, N DIN 11851 APV-Inline	0.1 to 9.84 ft/sec Relative value between 0 to 100%	Max. 1450 psig all except conical metal (232 psig)	-4 to +185°F

Transmitters	Housing	Display/Operation	Temperature (Ambient)	Power supply
Magphant Compact version	Compact Alu	LED	-4 to +140°F	DC 20 to 30 V
Flowphant DTT31 Compact version	Compact SS	One-line, backlit LCD Color change on faults, LED for status indication/Push buttons	-40 to +185°F	DC 18 to 30 V (reverse polarity protection)
Flowphant DTT35 Compact version	Compact SS	One-line, backlit LCD Color change on faults, LED for status indication/Push buttons	-40 to +185°F	DC 18 to 30 V (reverse polarity protection)

Materials (wetted parts)	Process connection	Protection	Approval/Certification	Measuring uncertainty ¹⁾ (best possible „accuracy“)
PVDF	Weld nipple	NEMA 4X (IP66)	Marine approvals	±2.0%
AISI 316L	Weld nipple, compression fitting, threaded connection: ASME, ISO	IP65	Marine approvals	±2.0 to 10% (depending on measuring range)
AISI 316L	Clamp ISO 2852, APV inline, Varivent, Conical metal-metal G½“, dairy thread (DIN 11851)	IP65	3-A; marine approvals	±2.0 to 10% (depending on measuring range)



Galvanic isolation	Inputs	Outputs	Communication	Ex approvals	Protection
No galvanic isolation	–	4–20 mA, relays	–	FM, CSA Div. 2	NEMA 4X (IP66)
No galvanic isolation	–	1 × or 2 × PNP switch outputs Optional 1 × PNP switch outputs and 1 × 4–20 mA output (active)	Programmable via PC (ReadWin 2000 and FieldCare®)	–	IP65
No galvanic isolation	–	1 × or 2 × PNP switch outputs Optional 1 × PNP switch outputs and 1 × 4–20 mA output (active)	Programmable via PC (ReadWin 2000 and FieldCare®)	–	IP65



Differential Pressure Flow Measurement



Flow measurement, Differential Pressure		
	Deltatop, Orifice plate (DO71W, DO74P, DO75F) 	Deltatop, Pitot tube (DP71B, DP72B, DP73B) 
Basic application	Gas, steam and liquids	Gas, steam and liquids
Nominal pipe size	3/8" to 40" depending on version	2" to 21 ft
Measuring range	Fluid dependent	Fluid dependent
Sensor type	Sharp edge orifice Bidirectional orifice Quarter circle nozzle orifice Conical inlet orifice Segmental orifice	Pitot tube
Process temperature	-328 to +1830°F	-328 to +1830°F
Process pressure	Up to 6300 psi	Up to 6300 psi
Process connections	ANSI Class 150, 300, 600, 900, 1500, 2500; 316L SS, C22.8 or A105 CS	ANSI Class 150, 300, 600, 1500; 316Ti SS Weld nipple, cutting ring, threaded; 316Ti SS
Transmitter	Deltabar S PMD75	Detabar S PMD75
Output	4 to 20 mA HART®, Profibus® and FOUNDATION™ Fieldbus	4 to 20 mA HART®, Profibus® and FOUNDATION™ Fieldbus
Ambient temperature	-40 to +185°F, transmitter	-40 to +185°F, transmitter
Power supply	11.5 to 45 VDC; Profibus® and FOUNDATION™ Fieldbus, 9 to 32 VDC	11.5 to 45 VDC; Profibus® and FOUNDATION™ Fieldbus, 9 to 32 VDC
Display / User interface	4-line LCD / Push buttons	4-line LCD / Push buttons
Approvals / certificates	FM, CSA, NACE, SIL	FM, CSA, NACE, SIL



Pressure Products available from Endress+Hauser

Gauge / Absolute

	Cerabar T		
	PMC 131	PMP 131	PMP 135
			
Application	Process pressure	Process pressure	Hygienic process
Measuring range	-15 to 600 psi	15 to 6000 psi	0 to 600 psi
Pressure sensor	Ceramic	Metallic	Metallic
Output	4 to 20 mA	4 to 20 mA PNP switch output 0-10 Voltage output	4 to 20 mA PNP switch output
Process temperature	-4 to +212°F	-13 to +158°F	-13 to +212°F (up to +275°F for 1 hour)
Power supply	11 to 30 VDC	12 to 30 VDC	12 to 32 VDC
Process connections	Threaded	Threaded	Mini-clamp Tri-clamp Threaded
Approvals / certificates	SIL	SIL	SIL, 3-A

	Ceraphant T	
	PTC31	PTP31
		
Application	Process pressure	Process pressure
Measuring range	1.5 to 600 psi	15 to 6000 psi
Pressure sensor	Ceramic	Metallic
Output	One PNP switch output Two PNP switch outputs PNP switch output with 4 to 20 mA (active)	One PNP switch output Two PNP switch outputs PNP switch output with 4 to 20 mA (active)
Process temperature	-40 to +212°F	-40 to +212°F
Power supply	12 to 30 VDC	12 to 30 VDC
Process connections	Threaded	Threaded
Approvals / certificates	UL	UL

	Cerabar M		
	PMC51	PMP51	PMP55
			
Application	Process pressure, level (gauge and absolute)	Process pressure, level (gauge and absolute)	Process pressure, level (gauge and absolute)
Measuring range	-15 to 600 psi	-15 to 6000 psi	-15 to 6000 psi
Pressure sensor	Ceramic	Metallic	Metallic with diaphragm seal
Output	4 to 20 mA / HART® Profibus-PA FOUNDATION™ Fieldbus	4 to 20 mA / HART® Profibus-PA FOUNDATION™ Fieldbus	4 to 20 mA / HART® Profibus-PA FOUNDATION™ Fieldbus
Ambient temperature	-40 to +185°F without display -4 to +158°F with display	-40 to +185°F without display -4 to +158°F with display	-40 to +185°F without display -4 to +158°F with display
Power supply	11.5 to 45 VDC 11.5 to 30 VDC for intrinsically safe unit	11.5 to 45 VDC 11.5 to 30 VDC for intrinsically safe unit	11.5 to 45 VDC 11.5 to 30 VDC for intrinsically safe unit
Process temperature	-40 to +212°F -40 to +266°F for hygienic process connections +302°F for max. of 60 min (for hygienic)	-40 to +257°F (internal diaphragms) -40 to +218°F (flush-mounted diaphragms) -40 to +266°F (hygienic connections max 302°F for 30 min.)	-94 to +752°F depending on seal and fill oil -4 to +158°F with display
Process connections	Threaded, ANSI flange, Tri-clamp, Varivent	Threaded, ANSI flange, Tri-clamp, Varivent	Threaded, Tri-clamp, ANSI flange, extended diaphragm, Varivent, separator
Approvals / certificates	FM, CSA, NSF 61, 3-A, SIL	FM, CSA, NSF 61, 3-A, SIL	FM, CSA, 3-A





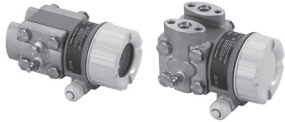

	Cerabar S		
	PMC71	PMP71	PMP75
			
Application	Process pressure, level	Process pressure, level	Process pressure, level
Measuring range	-15 to 600 psi	-15 to 10,500 psi	-15 to 6000 psi
Pressure sensor	Ceramic	Metallic	Metallic
Output	4 to 20 mA / HART® Profibus-PA FOUNDATION™ Fieldbus	4 to 20 mA / HART® Profibus-PA FOUNDATION™ Fieldbus	4 to 20 mA / HART® Profibus-PA® FOUNDATION™ Fieldbus
Process temperature	-13 to +257°F -4 to +302°F	-40 to +257°F (internal) -40 to +212°F (flush mount)	-94°F to +752°F depending upon diaphragm seal/fill fluid
Power supply	10.5 to 45 VDC 9 to 32 VDC (PROFIBUS, FF)	10.5 to 45 VDC 9 to 32 VDC (PROFIBUS, FF)	10.5 to 45 VDC 9 to 32 VDC (PROFIBUS, FF)
Process connections	Threaded ANSI flange	Threaded ANSI flange	Threaded ANSI flange Tri-clamp Varivent
Approvals / certificates	SIL, combination FM/CSA, NSF 61	SIL, combination FM/CSA, NSF 61	SIL, combination FM/CSA

NOTE:
The PMC51 replaces the PMC41/45
The PMP51 replaces the PMP41/45
The PMP55 replaces the PMP46/48





Tri-clamp® is a registered trademark of Ladish & Co., Inc., Kenosha, WI, USA
HART® is a registered trademark of HART Communication Foundation, Austin, TX, USA
Varivent® is a registered trademark of Tuchenhagen
PROFIBUS® is a registered trademark of PROFIBUS Nutzerorganisation e.V., Karlsruhe, D
FOUNDATION™ Fieldbus is a registered trademark of Fieldbus FOUNDATION, Austin, USA

Differential

Deltabar M	
	PMD55 
Application	Differential pressure, level, flow
Span (adjustable)	0.15 to 600 psi
Pressure sensor	Metallic
Output	4 to 20 mA HART® Profibus® PA FOUNDATION™ Fieldbus
Ambient temperature	-40 to +185°F
Process temperature	-40 to +185°F
Process temperature range, seals	FKM Viton: -4 to +185°F PTFE: -40 to +185°F NBR: -4 to +185°F EPDM: -40 to +185°F
Power supply	11.5 to 45 VDC
Process connections	Oval flange, 1/4-18 NPT, 316L SS or C22.8
Approvals/certificates	FM/CSA, SIL, 3-A

Deltabar S						
	PMD75	PMD70	FMD72	FMD76	FMD77	FMD78
						
Application	Differential pressure, level, flow	Differential pressure, level, flow	Differential pressure, level	Level	Level	Differential pressure, level
Span (adjustable)	4 inH ₂ O to 600 psi	10 inH ₂ O to 45 psi	12 inH ₂ O to 150 psi	40 inH ₂ O to 45 psi	40 inH ₂ O to 240 psi	40 inH ₂ O to 600 psi
Pressure sensor	Metallic	Ceramic	Metallic	Ceramic	Metallic	Metallic
Output	4 to 20 mA HART® Profibus® PA FOUNDATION™ Fieldbus	4 to 20 mA HART® Profibus® PA FOUNDATION™ Fieldbus	4 to 20 mA HART®	4 to 20 mA HART® Profibus® PA FOUNDATION™ Fieldbus	4 to 20 mA HART® Profibus® PA FOUNDATION™ Fieldbus	4 to 20 mA HART® Profibus® PA FOUNDATION™ Fieldbus
Process temperature	-40 to +248°F	-40 to +185°F	-40 to +257°F (Consult factory for temperatures above 257°F)	-40 to +185°F	-40 to +660°F	-40 to +660°F
Power supply	10.5 to 45 VDC 9 to 32 VDC (Profibus, FF)	10.5 to 45 VDC 9 to 32 VDC (Profibus, FF)	12 to 45 VDC	10.5 to 45 VDC 9 to 32 VDC (Profibus, FF)	10.5 to 45 VDC 9 to 32 VDC (Profibus, FF)	10.5 to 45 VDC 9 to 32 VDC (Profibus, FF)
Process connections	Threaded	Threaded	Threaded ANSI flange	Threaded ANSI flange Sanitary tank spud	Threaded ANSI flange	Threaded ANSI flange Tri-clamp® Varivent®
Approvals/certificates	SIL, FM/CSA	SIL, FM/CSA	FM/CSA	SIL, FM/CSA	SIL, FM/CSA	SIL, FM/CSA, 3-A

Hydrostatic

Deltapilot M				
	FMB50	FMB51	FMB52	FMB53
				
Application	Hydrostatic level/pressure Food, pharma, chemical	Hydrostatic level/pressure Food, pharma, chemical	Hydrostatic level/pressure Food, pharma, chemical	Hydrostatic level/pressure water, wastewater
Measurement range	-15 to 150 psi	-15 to 150 psi	-15 to 150 psi	-15 to 150 psi
Pressure sensor	Contite	Contite	Contite	Contite
Output	4 to 20 mA / HART® Profibus®-PA Foundation™ Fieldbus	4 to 20 mA / HART® Profibus®-PA Foundation™ Fieldbus	4 to 20 mA / HART® Profibus®-PA Foundation™ Fieldbus	4 to 20 mA / HART® Profibus®-PA Foundation™ Fieldbus
Process temperature	+14 to +212°F	+14 to +185°F	+14 to +158°F with PE Cable +14 to +176°F with FEP cable	+14 to +158°F with PE Cable +14 to +176°F with FEP cable
Power supply	11.5 to 45 VDC IS versions, 11.5 to 30 VDC	11.5 to 45 VDC IS versions, 11.5 to 30 VDC	11.5 to 45 VDC IS versions, 11.5 to 30 VDC	11.5 to 45 VDC IS versions, 11.5 to 30 VDC
Process connections	Threaded ANSI flange Flush-mounted hygienic	Threaded ANSI flange	Threaded ANSI flange	Remote electronics, suspension clamp for sensor
Approvals / certificates	FM, CSA, 3-A, NSF 61, SIL	FM, CSA, NSF 61, SIL	FM, CSA, NSF 61, SIL	FM, CSA NSF 61, SIL

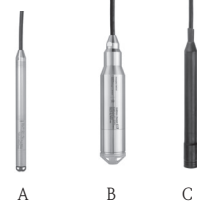
	Deltapilot S	Waterpilot
	FMB70 	FMX21  A B C
Application	Hydrostatic level, hygienic	Hydrostatic level
Measurement range	40 to 4000 inH ₂ O (1.5 to 150 psi)	1.5 to 300 psi (3 to 600 ftH ₂ O)
Pressure sensor	Contite®	Ceramic
Output	4 to 20 mA / HART® Profibus®-PA FOUNDATION™ Fieldbus	4 to 20 mA / HART®
Process temperature	+14 to +212°F (up to 275°F for 30 minutes)	+14 to +158°F (salt water version, 32 to 122°)
Power supply	10.5 to 45 VDC (10.5 to 30 VDC for intrinsically safe units) 9 to 32 VDC (Profibus, FF)	10.5 to 35 VDC Intrinsically safe, 10.5 to 30 VDC
Process connections	Universal mounting adapters, NPT, Tri-clamp®, ANSI flange, Varivent®	Mounting clamp Threaded mount
Approvals / certificates	FM/CSA, 3-A, SIL, NSF 61	FM, CSA, NSF 61

NOTE: The FMX21 waterpilot replaces the FMX167 waterpilot







Contite® is a registered trademark of Endress+Hauser GmbH+Co. KG, Maulburg, Germany









A-Standard 0.87" version
B-Heavy duty 1.66" version
C-Saltwater 1.15" version





FMB70 pressure transmitter
replaces DB50S transmitter





Temperature Products available from Endress+Hauser



iTEMP® Temperature Transmitters



	Field mounted		DIN rail mounted			
	TMT142 (Single input)	TMT162 (Dual input, dual-compartment housing)	TMT121	TMT122	TMT127	TMT128
						
RTD input	Pt100, Pt200, Pt500, Pt1000 Ni100, Ni500, Ni1000	Pt100, Pt500, Pt1000 Ni100, Ni500, Ni1000	Pt100, Pt500, Pt1000 Ni100, Ni500, Ni1000	Pt100, Pt500, Pt1000 Ni100, Ni500, Ni1000	Pt100	No
TC input	B, C, D, R, S, E, J, K, L, N, T, U	B, C, D, R, S, E, J, K, L, N, T, U	B, C, D, R, S, E, J, K, L, N, T, U	B, C, D, R, S, E, J, K, L, N, T, U	No	J, K, N, R, S, T
Ohms input	10 to 2000 Ω	10 to 2000 Ω	10 to 2000 Ω	10 to 2000 Ω	No	No
mV input	-20 to 100 mV	-20 to 100 mV	-10 to 100 mV	-10 to 75 mV	No	No
Output	HART®, 4 to 20 mA 20 to 4 mA	HART®, 4 to 20 mA/ 20 to 4 mA Profibus® PA FOUNDATION™ Fieldbus	4 to 20 mA 20 to 4 mA	HART®, 4 to 20 mA 20 to 4 mA	4 to 20 mA	4 to 20 mA
Ambient temperature	-40 to 185°F	-40 to 185°F	-40 to 185°F	-40 to +185°F	-40 to +185°F	-40 to +185°F
Power supply	11 to 40 VDC (8 to 40 VDC without display)	11 to 40 VDC (8 to 40 VDC without display)	12 to 35 VDC	12 to 35 VDC	12 to 35 VDC	12 to 35 VDC
Approvals/certificates	FM, CSA, CE, UL, ATEX	FM, CSA, SIL 2, UL, CE, ATEX	FM, CSA, UL, CE, ATEX	FM, CSA, UL, CE, ATEX	FM, CSA, UL, CE, ATEX	FM, CSA, UL, CE, ATEX

	Head transmitters								
	TMT180	TMT181	TMT187	TMT188	TMT182	TMT80	TMT84 (dual input)	TMT85 (dual input)	TMT82 (dual input)
									
RTD input	Pt100	Pt100, Pt500, Pt1000 Ni100, Ni500, Ni1000	Pt100	No	Pt100, Pt500, Pt1000 Ni100, Ni500, Ni1000	Pt100, Pt1000	Pt50, Pt100, Pt200, Pt500, Pt1000, Ni100, Ni120, Ni1000, Cu10, Cu50, Cu100	Pt50, Pt100, Pt200, Pt500, Pt1000, Ni100, Ni120, Ni1000, Cu10, Cu50, Cu100	Pt50, Pt100, Pt200, Pt500, Pt1000, Ni100, Ni120, Cu50
TC input	No	B, C, D, R, S, E, J, K, L, N, T, U	No	B, C, D, R, S, E, J, K, L, N, T, U	B, C, D, R, S, E, J, K, L, N, T, U	B, K, N, R, S	B, C, D, R, S, E, J, K, L, N, T, U	B, C, D, R, S, E, J, K, L, N, T, U	B, C, D, R, S, E, J, K, L, N, T, U
Ohms input	No	10 to 2000 Ω	No	No	10 to 2000 Ω	No	10 to 400 Ω, or 10 to 2000 Ω	10 to 400 Ω, or 10 to 2000 Ω	10 to 400 Ω, or 10 to 2000 Ω
mV input	No	-10 to 100 mV	No	No	-10 to 75 mV	No	-20 to 100 mV -5 to 30 mV	-20 to 100 mV	-20 to 100 mV
Output	4 to 20 mA 20 to 4 mA	4 to 20 mA 20 to 4 mA	4 to 20 mA	4 to 20 mA	HART®, 4 to 20 mA 20 to 4 mA	4 to 20 mA	Profibus® PA	FOUNDATION™ Fieldbus	HART®, 4 to 20 mA or 20 to 4 mA
Ambient temperature	-40 to 185°F	-40 to 185°F	-40 to 185°F	-40 to +185°F	-40 to +185°F	-40 to +185°F	-40 to +185°F	-40 to +185°F	-40 to +185°F
Power supply	10 to 35 VDC	8 to 35 VDC	8 to 35 VDC	8 to 35 VDC	11.5 to 35 VDC	8 to 35 VDC	9 to 32 VDC	9 to 32 VDC	11 to 42 VDC
Approvals/certificates	UL, CSA, CE	FM, CSA, UL, CE, ATEX	FM, CSA, UL, CE, ATEX	FM, CSA, UL, CE, ATEX	FM, CSA, UL, CE, ATEX	CE	FM, CSA, UL, CE, ATEX	FM, CSA, UL, CE, ATEX	FM, CSA, UL, CE, ATEX







RTD temperature sensors				
	TH11 	TH12 	TH17 	TH18 
Application	Process industry	Process industry	Hygienic, dairy, pharmaceutical	Hygienic, dairy, pharmaceutical
Measurement probe	Pt100	Pt100	Pt100	Pt100
Measuring range	-58 to +392°F / -328 to +1112°F	-58 to +392°F / -328 to +1112°F	-58 to +392°F	-58 to +392°F
Process connection	1/2" NPT, 316 SS 1/8" NPT compression, 316 SS 1/4" NPT compression, 316 SS	1/8" NPT compression, 316 SS 1/4" NPT compression, 316 SS	1" to 3" Tri-clamp®, 316L SS	1/2" or 3/4" Tri-clamp®, 316L SS
Output	Dependent on electronics, all iTEMP transmitters compatible	Dependent on electronics, all iTEMP transmitters compatible	Dependent on electronics, all iTEMP transmitters compatible	Dependent on electronics, all iTEMP transmitters compatible
Connection head	Aluminum, NEMA 4X Polypropylene, FDA, compliant, NEMA 4X	Aluminum, NEMA 4X Polypropylene, FDA, compliant, NEMA 4X	Aluminum, NEMA 4X Polypropylene, FDA, compliant, NEMA 4X	Aluminum, NEMA 4X Polypropylene, FDA, compliant, NEMA 4X
Ambient temperature	With head-mounted transmitter: -40 to +185°F Without head-mounted transmitter: Aluminum, -40 to +302°F Polypropylene, -40 to +185°F	With head-mounted transmitter: -40 to +185°F Without head-mounted transmitter: Aluminum, -40 to +302°F Polypropylene, -40 to +185°F	With head-mounted transmitter: -40 to +185°F Without head-mounted transmitter: Aluminum, -40 to +302°F Polypropylene, -40 to +185°F	With head-mounted transmitter: -40 to +185°F Without head-mounted transmitter: Aluminum, -40 to +302°F Polypropylene, -40 to +185°F
Minimum immersion	1", high temperature sensor 3/4", low temperature sensor	1-14", high temperature sensor 3/4", low temperature sensor	1-1/4"	3/4"
Immersion length	4", 6", 9", 12" 2" to 96", specified in 1/2" increments	6", 12", 18", 24" 2" to 96", specified in 1/2" increments	2", 2-1/2", 3", 4", 5", 6" 2" to 30", specified in 1/2" increments	3/4", 1-1/4", 2-1/4", 2-3/4" 1" to 15", specified in 1/4" increments
Approvals / certificates	Based on transmitter type used	Based on transmitter type used	Based on transmitter type used	Based on transmitter type used



RTD temperature sensors in Thermowells				
	TH13 	TH14 	TH15 	TH27 
Application	Process industry	Process industry	Process industry	Hygienic, dairy, pharmaceutical, biotech
Measurement probe	Pt100	Pt100	Pt100	Pt100
Measuring range	-58 to +392°F / -328 to +1112°F	-58 to +392°F / -328 to +1112°F	-58 to +392°F / -328 to +1112°F	-58 to +392°F / -328 to +1112°F
Process connection	1/2" NPT, 316 SS 3/4" NPT, 316 SS 1" NPT, 316 SS Socket weld, 3/4", 1", 316L SS Weld-in, 3/4", 1", 316L SS	1" ANSI flange, 316 SS 1-1/2" ANSI flange, 316 SS 2" ANSI flange, 316 SS	1/2" NPT, 316 SS+ Hex nipple or Nipple-Union-Nipple (NUN)	1", 2", 2-1/2", 3" Tri-clamp®, 316L SS 1" Hex nipple, 316 SS 1" NPT Nipple-Union-Nipple, 316 SS
Output	Dependent on electronics, all iTEMP transmitters compatible	Dependent on electronics, all iTEMP transmitters compatible	Dependent on electronics, all iTEMP transmitters compatible	Dependent on electronics, all iTEMP transmitters compatible
Connection head	Aluminum, NEMA 4X Polypropylene, FDA, compliant, NEMA 4X	Aluminum, NEMA 4X Polypropylene, FDA, compliant, NEMA 4X	Aluminum, NEMA 4X Polypropylene, FDA, compliant, NEMA 4X	Aluminum, NEMA 4X Polypropylene, FDA, compliant, NEMA 4X
Ambient temperature	With head-mounted transmitter: -40 to +185°F Without head-mounted transmitter: Aluminum, -40 to +300°F Polypropylene, -40 to +185°F SS, -40 to +300°F without display	With head-mounted transmitter: -40 to +185°F Without head-mounted transmitter: Aluminum, -40 to +300°F Polypropylene, -40 to +185°F SS, -40 to +300°F without display	With head-mounted transmitter: -40 to +185°F Without head-mounted transmitter: Aluminum, -40 to +300°F Polypropylene, -40 to +185°F SS, -40 to +300°F without display	With head-mounted transmitter: -40 to +185°F Without head-mounted transmitter: Aluminum, -40 to +300°F Polypropylene, -40 to +185°F SS, -40 to +300°F without display
Minimum immersion	Tapered thermowell: 4-1/2" Stepped thermowell: 2-1/2" Straight thermowell: 4" Weld-in thermowell: 4-1/2"	Tapered thermowell: 4-1/2" Stepped thermowell: 2-1/2" Straight thermowell: 4" Weld-in thermowell: 4-1/2"	Without thermowell: High temperature, 1-1/4" Low temperature, 3/4"	Without thermowell: High temperature, 1-1/4" Low temperature, 3/4" 1/2" straight thermowell, 4" 1/2" reduced thermowell, 2-1/2"
Immersion length	2-1/2", 4-1/2", 7-1/2", 10-1/2", 13-1/2", 16-1/2", 22-1/2" 2" to 24", specified in 1/2" increments	2", 4", 7", 10", 13", 16", 22" 2" to 24", specified in 1/2" increments	4", 6", 9", 12", 14" 4" to 30", specified in 1/2" increments	2-1/2", 3", 4", 4-1/2", 5", 6" 2" to 32", specified in 1/2" increments
Approvals / certificates	Based on transmitter type used	Based on transmitter type used	Based on transmitter type used	Based on transmitter type used

RTD temperature sensors in Thermowells, Explosion Proof			
	TH13	TH14	TH15
			
Application	Petrochemical, refineries	Petrochemical, refineries	Petrochemical, refineries
Measurement probe	Pt100	Pt100	Pt100
Measuring range	-58 to +392°F / -328 to +1112°F	-58 to +392°F / -328 to +1112°F	-58 to +392°F / -328 to +1112°F
Process connection	½" NPT, 316 SS ¾" NPT, 316 SS 1" NPT, 316 SS Socket weld, ¾", 1", 316L SS Weld-in, ¾", 1", 316L SS	1" ANSI flange, 316 SS 1½" ANSI flange, 316 SS 2" ANSI flange, 316 SS	½" NPT, 316 SS+ Hex nipple, 316 SS ½" NPT 316SS+ Nipple-Union-Nipple, 316 SS
Output	Dependent on electronics, iTEMP transmitters compatible	Dependent on electronics, iTEMP transmitters compatible	Dependent on electronics, iTEMP transmitters compatible
Connection head	Aluminum, NEMA 4X 316L SS, NEMA 4X	Aluminum, NEMA 4X 316L SS, NEMA 4X	Aluminum, NEMA 4X 316L SS, NEMA 4X
Ambient temperature	With head-mounted transmitter: -40 to +185°F Without head-mounted transmitter: Aluminum or SS, -50 to +212°F Field transmitter: With display, -40 to +158°F Without, -40 to +185°F	With head-mounted transmitter: -40 to +185°F Without head-mounted transmitter: Aluminum or SS, -50 to +212°F Field transmitter: With display, -40 to +158°F Without, -40 to +185°F	With head-mounted transmitter: -40 to +185°F Without head-mounted transmitter: Aluminum or SS, -50 to +212°F Field transmitter: With display, -40 to +158°F Without, -40 to +185°F
Minimum immersion	Tapered thermowell: 4½" Stepped thermowell: 2½" Straight thermowell: 4" Weld-in thermowell: 4½"	Tapered thermowell: 4½" Stepped thermowell: 2½" Straight thermowell: 4" Weld-in thermowell: 4½"	Without thermowell: High temperature, 1¼" Low temperature, ¾"
Immersion length	2½", 4½", 7½", 10½", 13½", 16½", 22½" ½" to 22½", specified in ½" increments	2", 4", 7", 10" 13", 16", 22" ½" to 22", specified in ½" increments	4", 6", 9", 12" 4" to 100", specified in ½" increments
Approvals / certificates	FM, CSA	FM, CSA	FM, CSA



Omnigrad M RTD temperature sensors		
	TR10	TR11
		
Application	Process industry	Process industry
Measurement probe	Pt100	Pt100
Measuring range	-328 to +1112°F	-58 to +392°F / -328 to +1112°F
Process connection	½" NPT: 316L SS, Alloy C276 ¾" NPT: 316L SS	½" NPT: 316L SS, Alloy C276 ¾" NPT: 316L SS
Neck tube	3" to 6"	Without
Process pressure range	Up to 1088 psi	Up to 1088 psi
Output	Dependent on electronics, all iTEMP transmitters compatible: 4 to 20 mA, HART®, Profibus® PA, FOUNDATION™ Fieldbus	Dependent on electronics, all iTEMP transmitters compatible: 4 to 20 mA, HART®, Profibus® PA, FOUNDATION™ Fieldbus
Terminal head	Aluminum, Polyamide, 316L SS	Aluminum, Polyamide, 316L SS
Ambient temperature	With head-mounted transmitter: -40 to +185°F Without head-mounted transmitter: Aluminum, -40 to +300°F Polyamide, -40 to +248°F 316L SS, -40 to +212°F With head mounted transmitter and display: -4 to +158°F	With head-mounted transmitter: -40 to +185°F Without head-mounted transmitter: Aluminum, -40 to +300°F Polyamide, -40 to +248°F 316L SS, -40 to +212°F With head mounted transmitter and display: -4 to +158°F
Maximum length	394"	394"
Protection tube, welded	Outer diameter: 0.35", 0.43" or 0.47"	Outer diameter: 0.35", 0.43" or 0.47"
Tip shape	Reduced, straight, tapered	Reduced, straight, tapered
Approvals / certificates	Based on transmitter type used	Based on transmitter type used

Thermocouple (TC) temperature sensors

Thermocouple (TC) temperature sensors				Thermocouple (TC) temperature sensors in Thermowells		
	TH51	TH52	TH56	TH53	TH54	TH55
						
Application	Process industry	Process industry	Process industry	Process industry	Process industry	Process industry
Measurement probe	TC type: J, K, E, N, or T	TC type: J, K, E, N, or T	TC type: J, K, E, N, or T	TC type: J, K, E, N, or T	TC type: J, K, E, N, or T	TC type: J, K, E, N, or T
Measuring range	-454 to +2500°F	-454 to +2500°F	-454 to +2500°F	-454 to +2500°F	-454 to +2500°F	-454 to +2500°F
Process connection	½" NPT, 316 SS 1/8" NPT compression 316 SS ¼" NPT compression 316 SS	1/8" NPT compression 316 SS ¼" NPT compression 316 SS	1/8" NPT compression 316 SS ¼" NPT compression 316 SS	½" NPT, 316 SS ¾" NPT, 316 SS 1" NPT, 316 SS Socket weld, ¾", 316 SS Weld-in, 1", 316SS	1" ANSI flange, 316 SS 1½" ANSI flange, 316 SS 2" ANSI flange, 316 SS	½" NPT, 316 SS + Hex nipple, 316 SS ½" NPT 316 SS + Nipple-Union-Nipple, 316 SS
Output	Dependent on electronics, iTEMP transmitter compatible	Dependent on electronics, iTEMP transmitter compatible	Dependent on electronics, iTEMP transmitter compatible	Dependent on electronics, iTEMP transmitter compatible	Dependent on electronics, iTEMP transmitter compatible	Dependent on electronics, iTEMP transmitter compatible
Connection head	Aluminum and Polypropylene, NEMA 4X	Cable with connector	Cable with connector	Aluminum and Polypropylene, NEMA 4X	Aluminum and Polypropylene, NEMA 4X	Aluminum and Polypropylene, NEMA 4X
Ambient temperature	With head-mounted transmitter: -40 to +185°F Without head-mounted transmitter: Aluminum -40 to +302°F Polypropylene, -40 to +185°F	Dependent on connector type, Standard, up to +350°F High temperature, up to +800°F	Dependent on connector type, Standard, up to +350°F High temperature, up to +800°F	With head-mounted transmitter: -40 to +185°F Without head-mounted transmitter: Aluminum -40 to +302°F Polypropylene, -40 to +185°F	With head-mounted transmitter: -40 to +185°F Without head-mounted transmitter: Aluminum -40 to +302°F Polypropylene, -40 to +185°F	With head-mounted transmitter: -40 to +185°F Without head-mounted transmitter: Aluminum -40 to +302°F Polypropylene, -40 to +185°F
Minimum immersion	10 x OD of sensor sheath, nominal	10 x OD of sensor sheath, nominal	10 x OD of sensor sheath, nominal	Tapered thermowell, 4½" Stepped thermowell, 2½"	Tapered thermowell, 4½" Stepped thermowell, 2½"	4"
Immersion length	6", 12", 18", 24" 2" to 96", specified in ½" increments	12", 18", 24", 48", 72", 96" 2" to 96", specified in ½" increments	4", 6", 9", 12" 4" to 96", specified in ½" increments	2½", 4½", 7½", 10½", 13½", 16½", 22½" 2 to 24", specified in ½" increments	2", 4", 7", 10" 2" to 24" specified in ½" increments	4", 6", 9", 12", 14" 4" to 30" specified in ½" increments
Approvals / certificates	Based on transmitter type used	Based on transmitter type used	Based on transmitter type used	Based on transmitter type used	Based on transmitter type used	Based on transmitter type used



Thermocouple (TC) temperature sensors in Thermowells, Explosion Proof			
	TH53	TH54	TH55
			
Application	Chemical, petrochemicals	Chemical, petrochemicals	Chemical, petrochemicals
Measurement probe	TC type: J, K, E, N, or T	TC type: J, K, E, N, or T	TC type: J, K, E, N, or T
Measuring range	-454 to +2500°F	-454 to +2500°F	-454 to +2500°F
Process connection	½" NPT, 316 SS ¾" NPT, 316 SS 1" NPT, 316 SS Socket weld, ¾", 316 SS Weld-in, 1", 316 SS	1" ANSI flange, 316 SS 1½" ANSI flange, 316 SS 2" ANSI flange, 316 SS	½" NPT, 316 SS + Hex nipple, 316 SS ½" NPT 316 SS + Nipple-Union-Nipple, 316 SS
Output	Dependent on electronics, iTEMP transmitter compatible	Dependent on electronics, iTEMP transmitter compatible	Dependent on electronics, iTEMP transmitter compatible
Connection head	Aluminum and 316L SS, NEMA 4X	Aluminum and 316L SS, NEMA 4X	Aluminum and 316L SS, NEMA 4X
Ambient temperature	With head-mounted transmitter: -40 to +185°F Without head-mounted transmitter: Aluminum, SS -58 to +212°F Field transmitter: -40 to +185°F w/o display -40 to +158°F w display	With head-mounted transmitter: -40 to +185°F Without head-mounted transmitter: Aluminum, SS -58 to +212°F Field transmitter: -40 to +185°F w/o display -40 to +158°F w display	With head-mounted transmitter: -40 to +185°F Without head-mounted transmitter: Aluminum, SS -58 to +212°F Field transmitter: -40 to +185°F w/o display -40 to +158°F w display
Minimum immersion	With thermowell: Tapered, 4½" Stepped, 2½" ¾" straight, 4" Weld-in, 4½"	With thermowell: Tapered, 4½" Stepped, 2½" ¾" straight, 4" Weld-in, 4½"	Without thermowell: 2½"
Immersion length	2½", 4½", 7½", 10½", 13½", 16½", 22½" 2 to 18", specified in ½" increments	2", 4", 7", 10", 13", 16", 22" 2" to 18" specified in ½" increments	4", 6", 9", 12" 4" to 100" specified in ½" increments
Approvals / certificates	FM, CSA	FM, CSA	FM, CSA



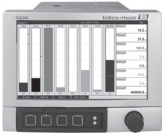

easytemp™ compact thermometer

Compact RTD transmitter		
	TMR31	
		
Application	General industry	Hygienic
Measurement probe	Pt100 (Class A)	Pt100 (Class A)
Measuring range	-58 to +302°F (w/o neck) -58 to +392°F (w/neck)	-58 to +302°F (w/o neck) -58 to +392°F (w/neck)
Process connection	¼" and ½" NPT; 316L Compression fitting, 316L (Metric sizes also available)	1", 1½", 2" Tri-clamp® (Metric sizes also available)
Output	Std: Pt100, Class A 4-wire Optional: 4 to 20 mA or 20 to 4 mA	Std: Pt100, Class A 4-wire Optional: 4 to 20 mA or 20 to 4 mA
Power supply	10 to 35 VDC	10 to 35 VDC
Ambient temperature	-40 to +185°F	-40 to +185°F
Immersion length	1.6 to 23.6"	1.6 to 23.6"
Approvals / certificates	UL, CE	UL, CE, 3A



Thermophant T temperature switch	
	TTR31
	
Application	Process control
Measurement probe	Pt100
Measuring range	-58 to +302°F
Process connection	¼" and ½" NPT
Output	One PNP switch output Two PNP switch outputs PNP switch output with 4 to 20 mA (active)
Power supply	12 to 30 VDC
Ambient temperature	-40 to +185°F
Approvals / certificates	UL

Data Acquisition and Components available from Endress+Hauser



Recorders			
	Minilog B RDL 10 	Memograph M RSG40 	Ecograph T RSG30 
Recorder type	Data recorder	Graphic data manager, paperless, record, visualize, analyze and communicate	Visual data manager, paperless
Application	Process monitoring	Process monitoring / control	Process monitoring / control
Input	1 analog, 1 discrete, universal	Up to 20 universal, 6 to 14 digital, 8 mathematics channels, Profibus®	3 or 6 analog, 3 digital
Input types	V, mA, RTD, TC	V, mV, mA, RTD, TC, frequency, pulse, Profibus® DP	V, mV, mA, RTD, TC
Setpoint control	2 per unit (display only; no output)	1 alarm relay, 5 NO relays for limit values, optional digital card with 6 NO relays	4 relays Up to 14 alarm setpoints
Plot or memory storage	Internal memory, 32K or 128K	Internal memory 256 MB, SD card or USB stick	Internal, 2 MB Flash, 2 MB SRAM External, CF cards from 32 MB to 512 MB
Interface	RS232	Integrated WEB server, Profibus®, Modbus, USB, TCP/IP, OPC, Ethernet, RS232/485	USB port, RS232/RS485 Ethernet, 7 integrated pushbuttons
Display type	7-digit LCD	7" TFT display, multicolor	5" color LCD
Ambient temperature	-13 to +131°F	14 to 122°F	32 to 122°F
Power supply	3.6 V battery or external power supply, 7 to 30 VDC	100 to 230 VAC 24 V AC/DC	100 to 230 VAC 24 V AC/DC
Approvals / certificates	CE	CE, UL, FDA 21, CFR 11	CE, UL



Multi-functional components				
	RIA452 	RIA45 	RIA46 	RIA251 
Component function	Digital display, Pump control	Digital display, process display and control unit	Digital display, process display and control unit, field mounted	Digital display Process display / monitoring
Input	Analog, digital	Analog, 1 or 2	Analog, 1 or 2	Analog, 1
Input types	V, mA, RTD, TC, digital	V, mA, resistance, RTD, TC	V, mA, resistance, RTD, TC	4 to 20 mA
Relay outputs/number	4 or 8 SPDT	2 SPDT (optional)	2 SPDT (optional)	N/A
Type of outputs	Relay, analog (U, I), pulse	Relay, 1 or 2 analog, digital status	Relay, 1 or 2 analog, digital status	4 to 20 mA only
Loop power to transmitter	24 V, 250 mA	24 to 230 VAC / VDC	24 to 230 VAC / VDC	N/A
Interface	RS232, ReadWin software, USB-box	FieldCare software, 3 pushbuttons, USB	FieldCare software, 3 pushbuttons, USB	3 pushbuttons
Display type	7-digit LCD, bar graph, status and digital input LEDs, limit value flags (1 to 8) 9 x 77 dot matrix	5-digit backlit LCD, dot matrix for text/bar graph, limit value indicators, channel display, status LEDs	5-digit backlit LCD, dot matrix for text/bar graph, limit value indicators, channel display, status LEDs	5-digit LCD
Ambient temperature	-4 to +140°F	-4 to +140°F	-40 to +122°F	-4 to +140°F
Power supply	90 to 250 VAC, 20 to 36 VDC, 20 to 28 VAC	24 to 230 V AC/DC	24 to 230 V AC/DC	Loop powered, 4 to 20 mA
Approvals / certificates	CE, FM, CSA, ATEX, TIIS	CE, FM, CSA, UL, ATEX	CE, FM, CSA, UL, ATEX	CE, FM, CSA, ATEX

Profibus® field indicator	
	RID261 
Component function	Digital display
Input types	Profibus® PA
Interface	2 dip switches
Display type	7-digit LCD, 0.30" character height
Ambient temperature	-15 to +140°F
Power supply	9 to 32 VDC (non-EEX), 9 to 15 VDC (EEX)
Approvals / certificates	CE, ATEX

Loop powered field indicator		
	RIA14	RIA16
		
Component function	Loop powered field indicator with explosion proof enclosure	Loop powered field indicator in field mounted housing
Input	4 to 20 mA	4 to 20 mA
Types of outputs	Open collector	Open collector
Display measuring range	-19999 to +99999	-19999 to +99999
Loop power to transmitter	4 to 20 mA	4 to 20 mA
Interface	3 push buttons, remote via FieldCare PC operating software	3 push buttons, remote via FieldCare PC operating software
Display type	5-digit backlit LCD, 0.8" height, trend bargraph in 10% increments	5-digit backlit LCD, 1.02" height, trend bargraph in 10% increments
Ambient temperature	-40 to +176°F	-40 to +176°F
Power supply	Loop-powered, 4 to 20 mA	Loop-powered, 4 to 20 mA
Approvals / certificates	CE, FM, CSA, UL, ATEX	CE, FM, CSA, UL, ATEX

Note: RIA14 and RIA16 replace the RIA261 and RIA141



Field indicator, FOUNDATION™ Fieldbus		
	RID14	RID16
		
Component function	Digital indicator	Digital indicator
Input	8-channel	8-channel
Display measuring range	-9999 to +99999	-9999 to +99999
Communication	FOUNDATION™ Fieldbus	FOUNDATION™ Fieldbus
Display type	5-digit backlit LCD, 0.8" height, trend bargraph in 10% increments, over/under range, units	5-digit backlit LCD, 1.02" height, trend bargraph in 10% increments, over/under range, units
Housing	Field mounted wall or pipe, aluminum (optional SS)	Field or panel mounted, plastic (aluminum optional)
Ambient temperature	-40 to +176°F	-40 to +176°F
Power supply	9 to 32 VDC, via fieldbus	9 to 32 VDC, via fieldbus
Approvals / certificates	CE, FM, CSA, UL, ATEX	CE, FM, CSA, UL, ATEX

Multi-functional components (DIN rail mounting)			
	RNS221	RN1221N	RMA42
			
Component function	Power supply for 2-wire systems	Power supply, active barrier for 2-wire systems	Digital process transmitter and control unit for monitoring analog measured values
Input	N/A	1 analog	1 or 2 universal
Input types	N/A	4 to 20 mA	V, mA, RTD, TC, resistance
Relay outputs/number	N/A	N/A	2 SPDT
Types of outputs	N/A	4 to 20	1 or 2: 0/4 to 20 mA, voltage 1 linearization table, 32 points Mathematics functions Open collector output
Loop power to transmitter	2 channels, 24 V, 30 mA	24 VDC, 22 mA	24 VDC, 22 mA
Interface	HART®	HART®	3 push buttons, USB, , HART®, FieldCare
Display type	3 LEDs	1 LED	5-digit backlit LCD, alarm markers, bar graph, LED relay indicators
Ambient temperature	-4 to +140°F	-4 to +122°F	-4 to +140°F
Power supply	20 to 250 VAC/VDC	20 to 250 VAC/VDC	24 to 230 VAC/VDC
Approvals / certificates	CE	CE, FM, CSA, ATEX	CE, FM, CSA, ATEX



Note:
RMA42 replaces the
RTA421, RMA421 and
RMA422

Safety barrier, DIN rail mount	
	RB223
	
Component function	Loop-powered barrier for separation of 4 to 20 mA signal circuits, one or two channel
Input	0/4 to 22 mA or specified accuracy 0 to 40 mA operating range
Output	0/4 to 22 mA for specified accuracy 0 to 40 mA operating range (max. current depends on load)
Power supply	Loop-powered, 0/4 to 20 mA
Ambient temperature	-4 to +140°F
Interface	HART® communication, bi-directional
Mounting	Standard top-hat DIN rail
Housing	Plastic PC, UL, 940
Approvals / certificates	CE, FM, CSA, UL, SIL 3, ATEX

Power supply Easy Analog	
	RNB130
	
Component function	Primary switched-mode power supply
Input	100 to 240 VAC
Output	24 VDC
Power supply	85 to 264 VAC
Ambient temperature	-13 to +158°F
Display element	DC OK LED, green
Mounting	Standard top-hat DIN rail
Housing	Polyamide PA
Approvals / certificates	CE







BTU / Steam manager		
	EngyCal RH33 BTU meter	EngyCal RS33 Steam calculator
		
Basic application	Custody transfer BTU meter heat/cold given off by liquids	Steam calculator for recording and billing steam mass and energy
Measuring range	Water: 32 to 662°F Water/glycol (0 to 60% glycol): -40 to +662°F Liquids: -328 to +1112°F	Steam: 32 to 1112°F Pressure: 0 to 14,500 psi
Calculation standards	IAPWS-IF 97, NAMUR NE21, NE43	IAPWS-IF 97, NAMUR NE21, NE43
Measurement/calculation	500 ms interval	500 ms interval
Housing	Wall/pipe mounting, panel or top-hat rail	Wall/pipe mounting, panel or top-hat rail
Inputs	2 Current/pulse, 2 Current/RTD 2 digital (activate tariff counter)	2 Current/pulse, 2 Current/RTD 2 digital (activate tariff counter)
Outputs	0/4 to 20 mA, pulse, 2 relays, 2 digital (open collector), 24 VDC	0/4 to 20 mA, pulse, 2 relays, 2 digital (open collector), 24 VDC
Display/Local operation	160 x 80 dot matrix with rear illumination, 3 soft-key pushbuttons, USB for configuration, 2 LED indicators	160 x 80 dot matrix with rear illumination, 3 soft-key pushbuttons, USB for configuration, 2 LED indicators
Interface	USB, Ethernet TCP/IP, RS485, Modbus TCP, Modbus RTU, M-Bus Internal data logging and logbook	USB, Ethernet TCP/IP, RS485, Modbus TCP, Modbus RTU, M-Bus Internal data logging and logbook
Operating software	Field Data Manager, FieldCare Device Setup	Field Data Manager, FieldCare Device Setup
Ambient temperature	-4 to +140°F	-4 to +140°F
Power supply	100 to 230 VAC, 24V AC/DC	100 to 230 VAC, 24 V AC/DC
Standards/approvals	OILM R75, MID (EN1434 water/liquids), UL, CE, CSA GP	OILM R75, CE, UL, CSA GP







Batch controller	
	RA33
	
Basic application	Batching and dosing of liquids, mass and volume flow
Function	Filling and dosing
Housing	Wall/pipe mounting, panel or top-hat rail
Inputs	0/4 to 20 mA / pulse for flow, 1 RTD 0/4 to 20 mA, pulse/frequency, 0/4 to 20 mA density
Outputs	0/4 to 20 mA or voltage pulse, 2 relay outputs, 2 digital (open collector, optional), 24 VDC transmitter power supply
Power supply	100 to 230 VAC 24 VAC / DC
Display / local operation	160 x 80 dot matrix with rear illumination, three operation push buttons, 14 function but- tons for batch operation or via FieldCare
Interface	USB (with CDI protocol, Ethernet TCP/IP, RS485, RS232 printer interface (optional), Modbus TCP, Modbus RTU
Operating software	Field Data Manager software Ms20, FieldCare Device Setup
Ambient temperature	-4 to +140°F
Standards / approvals	CE, UL, CSA GP



WirelessHART™		
	SWA70	SWG70 Fieldgate
		
Application	Battery powered interface module connecting HART® and 4 to 20 mA devices to a WirelessHART™ network	Gateway device for WirelessHART™ networks. Converts and stores wireless device data in a format compatible with other systems, host applications such as HMI / SCADA tools.
Input	One point to point HART® device, one point to point 4 to 20 mA device or up to 4 externally powered HART® devices operating in multidrop mode	WirelessHART™ communication interface
Output	WirelessHART™ communication interface	Ethernet (10 BASE-T/10 BASE TX), RS485 serial
Transmission range	Outdoor, 820 ft (250 m) Indoor, 165 ft (50 m)	Outdoor, 820 ft (250 m) Indoor, 165 ft (50 m)
Power supply	Long life lithium thionylchloride battery pack, 5 to 7.2 VDC	20 to 30 VDC
Battery life	5 to 7 years dependent on update rate, instru- ment type and environmental conditions	N/A
Ambient temperature	-40 to +176°F (temperature below -22°F, bat- tery pack capacity decreases rapidly)	-4 to +140°F
Antenna	Omnidirectional dipole, adjustable in vertical plane	Omnidirectional dipole, adjustable in vertical plane, optional remote antenna
Approvals / certificates	CE, FM, CSA, FCC Part 15.247	CE, FCC CFR 47 Part 15, ATEX



Analysis Products available from Endress+Hauser

Analysis pH

pH and pH Memosens Sensors							
	Orbisint CPS11 11D with Memosens	Ceraliquid CPS41 41D with Memosens	Ceragel CPS71 71D with Memosens	Orbipore CPS91 91D with Memosens	Tophit CPS441 441D with Memosens	Tophit CPS471 471D with Memosens	Tophit CPS491 491D with Memosens
							
Application	Process/environment	Food/biotechnology	Process/hygienic	Process/chemical	Process/environment	Process/environment	Process/ environment
Parameter	pH	pH	pH	pH	pH	pH	pH
Material	Glass	Glass	Glass	Glass	PEEK, EPDM	PEEK, EPDM	Peek, perfluoroelastomer
Measuring range	0 to 14 pH	0 to 14 pH	0 to 14 pH	0 to 14 pH	0 to 14 pH	0 to 14 pH	0 to 14 pH
Temperature	32 to 275°F	5 to 275°F	32 to 275°F	32 to 230°F	5 to 275°F	5 to 275°F	5 to 230°F
Temperature sensor	Pt100/Pt1000, NTC (11D)	Pt100/Pt1000, NTC (41D)	Pt100/Pt1000	Pt100/Pt1000, NTC (91D)	Pt1000	Pt1000	Pt1000
Process pressure	87 or 232 psi	145 psi	190 psi	190 psi	145 psi	145 psi	145 psi
Diaphragm	PTFE	Ceramic	Ceramic	Open	Ceramic	Ceramic	Open
Reference	Gel	Liquid	Gel	Solid gel	Liquid	Gel	Solid gel
Lengths (mm)	120/225/360/425	120/225/360/425	120/225/360/425	120/225/360/425	120/225/360/425	120/225/360/425	120/225/360/425
Sensor cable	CPK9, CYK10 (11D)	CPK9	CPK9, CYK10 (71D)	CPK9, CYK10 (91D)	CPK12, CYK10 (441D)	CPK12, CYK10 (471D)	CPK12, CYK10 (491D)
Approvals / certificates	FM	FM	FM, 3-A, biocompatible	FM	FM, CSA, 3-A, FDA	FM, CSA, 3-A, FDA	FM, CSA







ORP and ORP Memosens Sensors				pH Sensors		
	Orbisint CPS12/13 CPS12D with Memosens	Ceraliquid CPS42/43 CPS42D with Memosens	Ceragel CPS72 CPS72D with Memosens	Orbitex CPS21	Ceratex CPS31	CPS64
						
Application	Process/environment	Food/biotechnology	Process/hygienic	Water/wastewater	Municipal water	Process/environment
Parameter	ORP	ORP	ORP	pH	pH	pH
Material	Glass	Glass	Glass	Glass	Glass	Glass
Measuring range	-1500 to 1500 mV	-1500 to 1500 mV	-1500 to 1500 mV	2 to 12 pH	2 to 12 pH	0 to 14 pH
Temperature	5 to 275°F	5 to 275°F	5 to 275°F	32 to 140°F	32 to 140°F	5 to 265°F
Temperature sensor	NTC (12D)	NTC (42D)	N/A	Pt100	Pt100	N/A
Process pressure	232 psi	145 psi	232 psi	87 psi	9 psi	217 psi
Diaphragm	PTFE	Ceramic	Ceramic	Open ring junction	Ceramic	N/A
Reference	Gel	KCl liquid	Gel	Gel	Gel	CPS13/CPS43 Ref sensor
Lengths (mm)	120/225/360	120/225/425	120/225/360	120/150	120/150	120/425
Sensor cable	CPK9, CYK10 (12D)	CPK9, CYK10 (42D)	CPK9, CYK10 (72D)	CPK9	CPK9	CPK9
Approvals / certificates	CSA, FM (12D)	CSA, FM (42D)	FM, CSA (Not 72D)	General purpose	General purpose	General purpose

Combined pH/ORP Memosens Sensors			
	Memosens CPS16D 	Memosens CPS76D 	Memosens CPS96D 
Application	Process/environmental	Process/hygienic	Process/chemical
Parameter	pH/ORP	pH/ORP	pH/ORP
Material	Glass	Glass	Glass
Measuring range	0-14pH, -1500 to +1500mV (ORP)	0-14pH, -1500 to +1500mV (ORP)	0-14pH, -1500 to +1500mV (ORP)
Temperature	32 to 275°F	32 to 280°F	32 to 230°F
Temperature sensor	NTC 30KΩ	NTC 30KΩ	NTC 30KΩ
Process pressure	230 psi	190 psi	190 psi
Diaphragm	PTFE	Ceramic	Open
Reference	Gel	Gel	Gel
Lengths (mm)	120/225/360/425	120/225/360/425	120/225/360/425
Sensor cable	CYK10	CYK10	CYK10
Approvals / certificates	CSA, FM (Pending)	CSA, FM (Pending)	CSA, FM (Pending)





pH / ORP Sensors		
	Orbipac W CPF81/82 81D/82D with Memosens 	Purisys CPF201 
Application	Water/wastewater	Pure and ultrapure water
Parameter	pH / ORP	pH
Material	PPS / Glass	316L SS / Glass
Measuring range	0 to 14 pH / -1500 to +1500 mV	0 to 14 pH
Temperature	32 to 230°F	32 to 165°F
Temperature sensor	Pt100	Pt100/Pt1000
Process pressure	50 psi	50 psi
Diaphragm	PTFE	PTFE
Reference	Gel	Gel
Lengths (mm)	12.5/23/58.5	N/A
Sensor cable	Fixed cable, CPK9, CYK10 (81D/82D)	CPK9
Approvals / certificates	General purpose	General purpose







pH / Enamel Coated Sensor	
	Ceramax CPS341D Memosens for hygienic use 
Application	Water, active ingredient prep, fermentation, biotechnology, food/beverage
Parameter	pH, temperature
Material	Porcelain enamel metal substrate (PEMS)
Measuring range	-2 to 14 pH (0 to 10 pH linear range); 32 to 280°F measuring range
Temperature	32 to 280°F
Temperature sensor	NTC 30KΩ
Process pressure	0 to 87 psi
Diaphragm	¾", 1" threaded; 2" Tri-clamp®
Reference	Ag/AgCl with 3 M KCl and inhibitor
Lengths (mm)	120 mm
Sensor cable	CYK10
Approvals / certificates	General purpose



pH / ORP holder assemblies



	Dipfit W CPA 510 	Dipsys CPA 530 	Dipfit W CPA 111 	Dipfit P CPA 140 	Flowfit P CPA 240 	Flowfit W CPA 250 
Application	Water, wastewater, process	Water, wastewater, process	Water, wastewater, process	Process	Process	Water
Description	Single installation point for 120 mm, bayonet style holder	Single installation point, 120 mm electrode, PVC suspended holder, bayonet	3 installation points for 120 mm electrodes, bayonet style holder	3 installation points for 120 mm electrodes, bayonet style holder	3 installation points for 120 mm electrodes	3 installation points for 120 mm electrodes
Area of use	Open tank, channel, closed tank	Open tank, ducts, tall tanks	Open tank, channel, closed tank	Closed tank	Piping or bypass	Piping or bypass
Process connection	DN 50 (2") oval flange, 316 SS hanging bracket, DN 50 (2") flange	DN 50 (2") oval flange, 316 SS hanging bracket, DN 50 (2") flange	Suspended, lap joint flange or adjustable flange	3" Class 150 ANSI flange	1" Class 150 ANSI flange	1" Class 150 ANSI flange or G1 thread
Material	PVC, PVDF	PVC	Polypropylene	PVDF or 316L SS	PVDF or 316L SS	Polypropylene
Maximum pressure	87 psi	43 psi	60 psi	90 or 145 psi	120 or 145 psi	90 psi
Maximum temperature	+122°F	+68°F (+122°F non-pressurized)	+180°F	+250 or +300°F	+250 or +300°F	+180°F
Immersion depth	20 to 118 inches	Up to 33 feet	20 to 118 inches	20 to 100 inches	N/A	N/A
Sensor connection thread	Pg 13.5	Pg 13.5	3 x Pg 13.5	3 x Pg 13.5	3 x Pg 13.5	3 x Pg 13.5
Certificates	N/A	N/A	N/A	3.1.B EN 10204	3.1.B EN 10204	N/A
Associated cleaning systems	Cleaning can be accomplished without electrode removal	N/A	Integrated spray cleaning CPR 31 or external spray CPR 30	Integrated spray cleaning CPR 31	Spray cleaning connection G 1/2	Spray cleaning connection with CPR 3

pH / ORP holder assemblies



	Unifit H CPA 442 	Cleanfit W CPA 450 	Probfitt CPA 463S 	Cleanfit P CPA 471 	Cleanfit P CPA 472 
Application	Food, pharmaceuticals	Water, wastewater, process	Chemical, water, process	Water, wastewater, process	Water, wastewater, process
Description	Single 120 mm electrode with or without protection guard	Manual operation, 120 mm electrode	Pneumatic operation with flushing chamber, 120 mm electrode	Manual or pneumatic, can be fully automated with CPC30/310	Manual or pneumatic, can be fully automated with CPC30/310
Area of use	Open and closed tanks, piping	Open tank or closed tank and piping	Tank or piping	Tank or piping (min. 3" diameter)	Tank or piping (min. 3" diameter)
Process connection	1-1/2", 2" Tri-clamp, Weld socket	1-1/4" NPT or 1-1/4" Class 150 ANSI flange	2" Class 150 ANSI flange	2" Class 150 ANSI flange, 2" Tri-clamp, Varivent, 1-1/4" NPT	2" Class 150 ANSI flange, 1" NPT
Material	316L SS	316L SS, Alloy C4, titanium	PVDF, 316L SS, Alloy C4, PEEK	316L SS	Polypropylene, PVDF, PEEK
Maximum pressure	145 psi	60 psi	87 psi	60, 90, or 145 psi	60 or 90 psi
Maximum temperature	+285°F	+265°F	+68°F or +212°F (SS, Alloy C4)	+180 or +285°F	+140 or +180°F
Immersion depth	0.4 to 3.4 inches	Up to 28 inches	6.5" or 10.4"	2.6 to 8.2 inches	2.6 to 8.5 inches
Sensor connection thread	Pg 13.5	Pg 13.5	Pg 13.5	Pg 13.5	Pg 13.5
Certificates	3-A, 3.1.B EN 10204	3.1.B EN 10204	3.1.B EN 10204	3.1.B EN 10204	N/A
Associated cleaning systems	N/A	Rinse chamber connection G 1/4	Integrated rinse chamber, can be combined with automatic Airtrol calibration system	Integrated rinse chamber with connection, 1/4" NPT	Integrated rinse chamber with connection, 1/4" NPT

pH / ORP holder assemblies						
	Cleanfit P CPA 472D 	Cleanfit P CPA 473 	Cleanfit P CPA 474 	Cleanfit H CPA 475 	Cleanfit P CPA 477 	Echofit CPA 640 
Application	Chemical, power, process	Water, wastewater, process	Water, wastewater, process	Food, pharmaceuticals	Chemical, wastewater	Replacement kit
Description	Manual or pneumatic, can be fully automated with CPC30/310	Manual or pneumatic, can be fully automated with CPC30/310	Manual or pneumatic, can be fully automated with CPC30/310	Manual or pneumatic, can be fully automated with CPC30/310	Pneumatic with pneumatic or electric limit switches	Single installation point, 12 mm dia. glass electrodes, 120 mm
Area of use	Tank or piping (min. 4" diameter)	Tank or piping (min. 3" diameter)	Tank or piping (min. 3" diameter)	Tank or piping (min. 3" diameter)	Tank or piping (min. 3" diameter)	Process connection adapter for various electrodes
Process connection	2" Class 150 ANSI flange	2" Class 150 ANSI	2" Class 150 ANSI	2" Tri-clamp 2" Class 150 ANSI flange	Slotted nut Rd 65 x1/6	1/2" NPT, 3/4" NPT, 1" NPT
Material	PVDF, PEEK, 316L SS, Hastelloy C4, Titanium	316L SS	Polypropylene, PVDF, PEEK	316L SS	316L SS	PVDF, 316 Ti SS
Maximum pressure	60 or 145 psi	60, 90, or 145 psi	60, 90, or 145 psi	60, 90, or 145 psi	87 psi	150 psi
Maximum temperature	+32 to +284°F	+180 or +285°F	+180 or +265°F	+180 or +285°F	+40 to +194°F	+70°F (+285°F, SS version)
Immersion depth	5.8 to 11.2 inches	2.4 to 9.3 inches	2.8 to 8.1 inches	1.9 to 4 inches	4.7 inches	1", 2", 3.4"
Sensor connection thread	Pg 13.5	Pg 13.5	3/4" NPT (CPF 81/82)	Pg 13.5	Pg 13.5	Pg 13.5
Certificates	3.1.B EN 10204	3.1.B EN 10204	N/A	3-A, 3.1.B EN 10204	N/A	N/A
Associated cleaning systems	Integrated rinse chamber with connection, 1/4" NPT	Integrated rinse chamber with connection, 1/4" NPT	Integrated rinse chamber with connection, 1/4" NPT	Integrated rinse chamber with connection, 1/4" NPT	Integrated rinse chamber with connection, 1/4" NPT, 1/2" NPT	N/A

Modular holder assemblies		
	Flexdip CYH 112 	Flexdip CYA 112 
Application	Water and wastewater	Water and wastewater
Description	Single installation point, flexible holder system: for floor, wall or rail mounting	Standard immersion pipe, chain immersion pipe or float immersion pipe
Area of use	Basins, open channels, open tanks, process vats	Basins, open channels, open tanks, process vats
Sensor installation	Cantilever arm with chain, fixed immersion pipe, free swinging or float-lever version for varying levels	Various sensor connection threads or chain mount adapter. Straight or 45° angle mounting
Compatible sensor holder assemblies	Flexdip CYA112, Dipfit W CLA111, Dipfit W CPA111	Flexdip CYH112
Material	Stainless steel and plastic	Stainless steel and PVC
Ambient temperature	-4 to +140°F	-4 to +140°F
Main pipe height	20", 40", 71"	Lengths vary depending on application
Cantilever arm length	20", 40", 59"	N/A

pH / ORP Transmitters			
	Mycom S CPM153 	Liquisys M CPM223/253 	Liquiline CM42 
Application	Chemical, pharmaceutical, food, water	Chemical, pharmaceutical, food, water	Chemical, pharmaceutical, food, water
Measurement type	pH, ORP 4-wire transmitter 1 or 2 measuring circuits, up to 5 relays	pH, ORP 4-wire transmitter 1 or 2 measuring circuits, 2 or 4 relays	2-wire transmitter for pH, ORP, conductivity, dissolved oxygen, concentration
Measurement range	pH: -2 to +16 pH ORP: -1500 to +1500 mV Temperature: Pt100, Pt1000, NTC, or PTC -58 to +392°F	pH: -2 to +16 pH ORP: -1500 to +1500 mV Temperature: Pt100, Pt1000, -58 to +302°F NTC 30K, -4 to +212°F	pH: -2 to +16 pH ORP: -1500 to +1500 mV Temperature: Pt100, Pt1000, NTC 30K -10 to +300°F
Output	0/4 to 20 mA, 15 VDC (digital) Automatic clean and calibration functions	0/4 to 20 mA, 15 VDC (digital) Automatic clean and calibration functions	1 x 4 to 20 mA + HART®, 2 x 4 to 20 mA + HART® Automatic clean and calibration functions
Input	4 to 20 mA, 6 to 30 V, 0 to 10 kOhm, 10 to 50V digital (Memosens®)	4 to 20 mA, 6 to 30 V, 0 to 10 kOhm, 10 to 50V digital (Memosens®)	Glass iSFET, digital (Memosens®) sensors
Power supply	100 to 230 VAC 24 VAC/VDC	100/115/230 VAC 24 VAC/VDC	12.5 to 30 VDC; Profibus® or fieldbus 9 to 32 VDC (non-hazardous) or 9 to 17.5 VDC (hazardous)
Ambient temperature	14 to 131°F (FM, 14 to 122°F)	14 to 131°F	-20 to +175°F
Mounting	Wall, pipe	Wall, pipe, panel mount (CPM223)	Wall, pipe, panel mount
Operation	Via push buttons and dot matrix LCD display, HART® or Profibus® PA, RS232 (DAT module)	Via push buttons and dot matrix LCD display, HART® or Profibus® PA	Via soft keys, LCD display, and navigator; HART®, Profibus® PA and FOUNDATION™ fieldbus
Housing	Aluminum, plastic coated	Field housing: ABS PC Fr, polyester front Panel mount: Polycarbonate, polyester front	Polycarbonate plastic housing or 304 SS housing
Approvals / certificates	CE, FM, CSA	CE, FM, CSA	CE, FM, CSA, SIL 2

pH / ORP Transmitters	
	Liquiline® CM442/CM444/CM448 Digital Memosens® Transmitter 
Application	Water/wastewater, power, chemical, process industries
Measurement type	Memosens® transmitter for pH, ORP, conductivity, dissolved oxygen, turbidity, nitrate
Measurement range	Dependent on sensor type
Output	Up to 8, 4-20 mA, up to 4, SPDT relays Automatic clean and calibration functions
Input	1 to 8 digital Memosens® sensors (Memosens® sensors only)
Power supply	100 to 230 VAC 24 VAC 24 VDC
Ambient temperature	-4 to +140°F
Mounting	Wall, pipe, panel mount
Operation	Via soft keys, LCD display, and navigator; Integration into FieldCare® and W@M asset management
Housing	Polycarbonate plastic housing
Approvals / certificates	FM/CSA = CM442 only (Cl I, Div. 2) CE, cCSAus

Automatic cleaning / calibration			
	Autoclean/chemoclean Cyr 10 / Cyr 20	Topclean S CPC 30	Topcal S CPC 310
			
Application	Chemical, water, wastewater	Pharmaceutical, food, water	Pharmaceutical, food, wastewater, process
Measurement type	pH/ORP	pH/ORP/temperature	pH/ORP/temperature
System capabilities	Cleaning, rinsing	Sterilization, cleaning, rinsing	Calibration, sterilization, cleaning, rinsing
System components *	pH/ORP electrode, electrode holder assembly, program controller, Cyr 10 injector, spray nozzle	pH/ORP electrode, pneumatic electrode holder assembly (with pneumatic or electric limit switches), CPG 30 control unit, Cyr 10 injector assembly, transmitter CPM 153	pH/ORP electrode, pneumatic electrode holder assembly (with pneumatic limit switches), CPG 310 control unit, buffer/cleaner solutions containers, membrane pumps for buffer and cleaning solutions, rinsing block, transmitter CPM 153
Basic functions	Cleaning time, rinse time, cleaning cycle, weekly program via relays	Cleaning time, rinse time, cleaning cycle, weekly program, daily program, DAT module, electrode holder control, six relay contacts, two current outputs	Cleaning cycle, weekly program, in-process cleaning/calibration, DAT module, electrode holder control, calibration to buffer tables, limit values and alarm functions, digital inputs and outputs, six relay contacts, two current outputs
Power supply	110, 230 VAC 24 VDC	100 to 115 VAC, 230 VAC 24 VC/DC	100 to 230 VAC 24 VC/DC
Ambient temperature	Cyr 20: +32 to +122°F Cyr 10: +23 to +104°F	CPG 30: +14 to +131°F Cyr 10: +23 to +104°F	CPG 310: +14 to +131°F
Mounting	Cyr 20: DIN rail mount, panel mount Cyr 10: wall mount	CPG 30: wall mount Cyr 10: wall mount CPM 153: wall or panel mount	CPG 310: wall mount CPM 153: wall or panel mount
Programming	Push button and 4-digit LCD	Mycom S CPM 153 transmitter, HART, Profibus-PA	Mycom S CPM 153 transmitter, HART, Profibus-PA
Housing	Cyr 20: PC/ ABS Cyr 10: PVC	CPG 30: Polyester GF Cyr 10: PVC CPM 153: aluminum, plastic coated	CPG 310: Polyester GF CPM 153: aluminum, plastic coated
Approvals / certificates	General purpose	FM, CSA	CE, FM, CSA







* Electrode, electrode holder, spray nozzles are purchased separately



Memosens	
	
Application	Food and beverage, chemical, water, wastewater, process industries
Description	Digital transmission of pH signals via cable using contact-less inductive connection. Current calibration data is stored in sensor head.
Area of use	Used with CPS 11D, 71D, 91D, CPS 441D, 471D, and 491D memosens pH electrodes and connects to CPM 153, Liquiline CM 42 CPM 223/253 transmitters via CYK 10 cable
Electrode connection	Twist-lock plug-in connector, water tight
Material	Sensor plug-in: PPS-40GF Cable coupling: PEEK
Process temperature	Depending on sensor, max. +275°F
Process pressure	Depending on sensor, operated up to a safety pressure of 725 psi at +275°F
Certificates	Data cable CYK 10: FM, CSA



Memocheck *	
	Memocheck Plus CYP01D Memocheck CYP02D Memocheck Sim CYP03D 
Application	Test tools for measuring points with Memosens to simulate digital signal transmission
Area of use	Checking all parameters of pH, ORP, conductivity, dissolved oxygen, chlorine, turbidity, nitrate Connects to any transmitter with Memosens technology
Transmitter connection	CYK10 data cable, twist-lock memosens coupling
Material	CYP01D/CYP02D: PET (white plastic), PPS GF 40 (blue plastic) CYP03D: ABS (UL 94 HB)
Power supply	CYP03D only: 3 AA 1.5 V batteries
Ambient temperature	CYP01D/CYP02D: 5 to 158°F CYP03D: 0 to 122°F
Certificates	FM, CSA (CYP03D, non-hazardous only)

* Depending on order code selection, the Memocheck system can be used for ORP, conductivity, chlorine, dissolved oxygen, turbidity, and nitrate. Contact Endress+Hauser for details.





Analysis Conductivity

Conductivity Sensors							
	Condumax W CLS12 	Condumax W CLS13 	Condumax W CLS15, CLS15D with Memo- sens® 	Condumax H CLS16, CLS16D with Memosens® 	Condumax W CLS19 Compact 	Condumax W CLS21, CLS21D with Memosens® 	Condumax W CLS30 
Application	Industrial, water	Industrial high temperature	Pure, ultrapure water	Pure, ultrapure water	Pure, ultrapure water	Water, wastewater	Industrial water
Parameter	Conductivity	Conductivity	Conductivity	Conductivity	Conductivity	Conductivity	Conductivity
Material	316L SS	316 Ti SS	316L SS	316L SS	316Ti SS	Graphite	Graphite / titanium
Measuring range	0.04 to 20 µS/cm 0.1 to 200 µS/cm	0.04 to 20 µS/cm 0.1 to 200 µS/cm	0.04 to 20 µS/cm 0.1 to 200 µS/cm	0.04 to 500 µS/cm	0.04 to 20 µS/cm 0.1 to 200 µS/cm	10 µS/cm to 20 mS/cm	0.1 mS/cm to 200 mS/cm
Temperature	-22 to +320°F	-4 to +482°F	Threaded: -4 to +212°F Tri-clamp®: -4 to +266°F -4 to +248°F CLS15D	23 to 248°F 23 to 266°F, CLS16D	14 to 140°F	-4 to +275°F	-4 to +257°F, PTFE -4 to +194°F, PP
Temperature sensor	Integrated Pt100	Integrated Pt100	Pt100, NTC (CLS15D)	Pt100/1000, NTC (CLS16D)	Integrated Pt100	Pt100, NTC (CLS21D)	Integrated Pt100/PTC
Process pressure	580 psi (up to 212°F) 174 psi (up to 302°F)	580 psi	174 psi at 68°F	174 psi at 68°F	87 psi	232 psi at 68°F	87 psi (PTFE) 232 psi (PP)
Insertion depth	Minimum 2"	Minimum 2"	Minimum 1.26"	Minimum 0.79"	Minimum 1.38"	Minimum 0.63"	Minimum 2.5"
Process connection	1" NPT (316 Ti SS)	1" NPT (316 Ti SS)	Fixed cable: ½" NPT (PES), 1½" Tri-clamp® (316L SS) Connector: ¾" NPT (PES), 1½" Tri-clamp® (316L SS)	1", 1½", 2" Tri-clamp® (316L SS), 2 to 5" Varivent	½" NPT (PES)	¾" NPT (PES) 1" NPT (PES) 2" Tri-clamp® (PES or SS)	1" NPT (316 Ti SS, PES) ¾" NPT (PES)
Sensor cable	CYK71	CYK71	CYK71, CYK10 (CLS15D)	CPK9, CYK10 (CLS16D)	CYK71	CYK71, CYK10 (CLS21D)	CYK71
Approvals / certificates	FM (when used with CLM431, CLM153 and Liquiline® M CM42 transmitters)	FM (when used with CLM431, CLM153 and Liquiline® M CM42 transmitters)	FM (when used with CLM431, CLM153 and Liquiline® M CM42 transmitters)	FM (when used with CLM431, CLM153 and Liquiline® M CM42 transmitters), 3A	General purpose	FM (when used with CLM431, CLM153 and Liquiline® M CM42 transmitters)	FM (when used with CLM431 and CLM153 transmitters)

Conductivity Sensors			
	Indumax P CLS50 CLS50D with Memosens® 	Indumax H CLS52 	Indumax H CLS54 CLS54D with Memosens® 
Application	Chemical, process	Food, beverage, pharmaceutical	Food, beverage, pharmaceutical
Parameter	Conductivity	Conductivity	Conductivity
Material	PFA/PEEK™	PEEK™	Virgin PEEK™
Measuring range	2 µS/cm to 2000 mS/cm	10 µS/cm to 2000 mS/cm	100 µS/cm to 2000 mS/cm
Temperature	-4 to +356°F	23 to 257°F	14 to 257°F
Temperature sensor	Integrated Pt100	Integrated Pt100	Integrated Pt1000
Process pressure	290 psi (without flange) 232 psi (with flange)	232 psi	232 psi 174 psi (CLS54D)
Insertion depth	Sensor head must be completely submerged	Minimum 1.3"	Sensor head must be completely submerged
Process connection	1" NPT (PEEK™) 2" Class 150 ANSI (PVDF) 2" Class 150 ANSI (316L SS)	2" Tri-clamp® 2" Perlick Varivent®	2" Tri-clamp® Varivent® NEUMO BioControl D50
Sensor cable	Fixed cable, CYK10 (CLS50D)	CLK5 fixed cable	CLK5 fixed cable, CYK10 (CLS54D)
Approvals / certificates	FM (when used with CLM431, CLM153 and Liquiline® M CM42 transmitters)	General purpose	General purpose, 3A, EHEDG, FDA, USP class VI, FM (when used with Liquiline® M CM42)

Conductivity Holder Assemblies		
	Dipfit W CLA 111 	Dipfit P CLA 140 
Application	Water, wastewater, process	Chemical, wastewater, process
Description	Single installation point, CLS21 or CLS50 electrode, immersion holder	Single installation point for CLS50 electrode, immersion holder, bayonet style
Area of use	Open channels, basins, tanks	Open tank, channel, closed tank
Process connection	Adjustable flange, suspension bracket, mounting bracket	3" Class 150 ANSI flange
Material	Polypropylene	316L SS, PVDF
Maximum pressure	Non-pressurized systems	145 psi
Maximum temperature	176°F	302°F
Immersion depth	3 to 10 ft	1.5 to 7.5 ft
Sensor connection thread	G1, G¾	G¾
Certificates	N/A	N/A
Associated cleaning systems	External spray cleaning (CLR30 spray head)	N/A

Conductivity Transmitters

	Smartec S CLD132	Smartec S CLD134	Liquiline® M CM42	Mycom S CLM153	Liquisys M CLM223/253
					
Application	Chemical, beverage, water	Food, beverage, pharmaceutical and biotech	Chemical, pharmaceutical, food, water	Chemical, pharmaceutical, food, water	Ultrapure water, water treatment, cooling water
Measurement type	Conductivity 4-wire transmitter	Conductivity 4-wire transmitter	2-wire transmitter for pH, ORP, conductivity, dissolved oxygen, concentration	Conductivity 4-wire transmitter 1 or 2 measuring circuits, up to 5 relays	Conductivity 4-wire transmitter 1 or 2 measuring circuits, 2 or 4 relays
Measurement range	Conductivity: 0 µS/cm to 2000 mS/cm Temperature: 14 to 302°F	Conductivity: 100 µS/cm to 2000 mS/cm Concentration: 0 to 30% Temperature: -31 to +482°F	Conductivity: 0.1 µS/k to 20 mS/k Resistivity: 10 MΩ/k to 50 Ω/k Concentration: 0 to 30% Temperature: Pt100, Pt1000	Conductivity: 0.04 µS/cm to 2000 mS/cm Temperature: Pt100/Pt1000, -31 to +482°F, NTC, -31 to +482°F	Conductivity: 0.01 µS/cm to 1000 mS/cm Temperature: Pt100, -31 to +482°F
Output	0/4 to 20 mA, HART®, Profibus®	0/4 to 20 mA, HART®, Profibus®, temperature	1 x 4 to 20 mA + HART®, 2 x 4 to 20 mA + HART® Automatic clean and calibration functions	0/4 to 20 mA, 15 VDC (digital) Automatic clean and calibration functions	0/4 to 20 mA, 15 VDC (digital) Automatic clean and calibration functions
Input	0/4 to 20 mA 10 to 50 V digital (inputs 1 and 2)	0/4 to 20 mA 10 to 50 V digital (inputs 1 and 2), Pt1000 switchable to Pt100	Analog sensors, two and four electrode, conductivity (inductive and resistive), concentration	4 to 20 mA, 6 to 30 V, 0 to 10 kOhm, 10 to 50V digital	0 to 2000 mS/cm, 10 to 50 VDC (digital)
Power supply	100/115/230 VAC 24 VAC/VDC	100/115/230 VAC 24 VAC/VDC	12.5 to 30 VDC; Profibus® or fieldbus 9 to 32 VDC, (non-hazardous) or 9 to 17.5 VDC (hazardous)	100 to 230 VAC 24 VAC/VDC	100/115/230 VAC 24 VAC/VDC
Ambient temperature	-13 to +158°F	32 to +131°F	-20 to +175°F	14 to 131°F (FM, 14 to 122°F)	14 to 131°F
Mounting	Compact: direct via CLS52 sensor Remote: Wall, pipe	Compact: direct via CLS54 sensor Remote: Wall, pipe	Wall, pipe, panel mount	Wall, pipe, panel mount	Wall, pipe., panel mount (CPM223)
Operation	Via push buttons and LCD display, HART® or Profibus® PA/DP	Via push buttons and LCD display, HART® or Profibus® PA/DP	Via soft keys, LCD display, and navigator; HART®, Profibus® PA and FOUNDATION™ fieldbus	Via push buttons and dot matrix LCD display, HART® or Profibus® PA, RS232 (DAT module)	Via push buttons and dot matrix LCD display, HART® or Profibus® PA
Housing	304 SS	304 SS	Polycarbonate plastic housing or 304 SS housing	Aluminum, plastic coated	Field housing: ABS PC Fr, polyester front Panel mount: Polycarbonate, polyester front
Approvals / certificates	General purpose	General purpose, 3A, EHEDG, FDA, USP class VI	CE, FM, CSA, SIL2	CE, FM, CSA	CE, FM, CSA

Conductivity Transmitter

	Liquisys S CLM223F
	
Application	Food, beverage
Measurement type	Conductivity and resistance 4-wire transmitter, 3 relays, 2nd current output for temperature
Measurement range	Conductivity: 0 to 200 mS/cm Resistance: 0 to 200 MΩ Temperature: Pt100, Pt1000, NTC -31 to +482°F
Output	0/4 to 20 mA, 15 VDC (digital)
Input	0/4 to 20 mA, 0 to 2000 mS/cm, 10 to 50 VDC (digital)
Power supply	100/115/230 VAC 24 VAC/VDC
Ambient temperature	14 to 131°F
Mounting	Panel mount
Operation	Via push buttons and dot matrix LCD display
Housing	Panel mount: Polycarbonate, polyester front
Approvals / certificates	General purpose





Conductivity Transmitter, Memosens®

	Liquiline® CM442/CM444/CM448 Digital Memosens® Transmitter
	
Application	Water/wastewater, power, chemical, process industries
Measurement type	Memosens® transmitter for pH, ORP, conductivity, dissolved oxygen, turbidity, nitrate
Measurement range	Dependent on sensor type
Output	Up to 8, 4-20 mA, up to 4, SPDT relays Automatic clean and calibration functions
Input	1 to 8 digital Memosens® sensors (Memosens® sensors only)
Power supply	100 to 230 VAC 24 VAC 24 VDC
Ambient temperature	-4 to +140°F
Mounting	Wall, pipe, panel mount
Operation	Via soft keys, LCD display, and navigator; Integration into FieldCare® and W@M asset management
Housing	Polycarbonate plastic housing
Approvals / certificates	FM/CSA = CM442 only (Cl I, Div. 2) CE, cCSAus



Conductivity Calibration	
	<p>Conductivity calibration Concal</p> 
Application	Pharmaceutical, food, ultrapure water
Measurement type	Conductivity calibration
Measurement range	Up to 20 $\mu\text{S}/\text{cm}$ or $\text{M}\Omega$, adjustable
Reference electrode	CLS15
Reference transmitter	CLM153
Power supply	115 VAC
Fluid temperature range	32 to 212°F
Pressure maximum	87 psi (flow assembly)
Minimum flow	0.13 GPM (flow assembly)
Approvals / certificates	ASTM 5391-93



Conductivity Calibration Solutions	
	<p>Precision calibration solution CLY11</p> 
Application	Field calibration for conductivity electrodes
Measurement type	Conductivity
Calibration solution (at 76°F)	CLY11-A: 74.0 $\mu\text{S}/\text{cm}$ CLY11-B: 149.6.0 $\mu\text{S}/\text{cm}$ CLY11-C: 1.406 mS/cm CLY11-D: 12.64 mS/cm CLY11-E: 107.00 mS/cm
Storage temperature	14 to 122°F
Approvals / certificates	Traceable to : ASTM 5391-93

Analysis Chlorine

Chlorine Sensors				
	Total chlorine CCS120	Free chlorine CCS140/141	Chlorine dioxide CCS 240/241	Free chlorine Chloromax CCS142D
				
Application	Drinking, industrial water	Drinking, industrial water	Drinking, industrial water	Drinking, process, industrial water
Parameter	Total chlorine	Free chlorine	Chlorine dioxide	Free chlorine
Material	PVC, PPE membrane	PVC, PTFE membrane (membrane cap replaceable)	PVC, PTFE membrane (membrane cap replaceable)	PVDF, PTFE membrane (membrane cap replaceable)
Measuring range	0.1 to 10 ppm	CCS140: 0.05 to 20 mg Cl ₂ /l CCS141: 0.01 to 5 mg Cl ₂ /l (CCS140/141, at 76°F, pH 7.2)	CCS240: 0.05 to 20 ppm ClO ₂ CCS241: 0.01 to 5 ppm ClO ₂	142D-A: 0.05 to 20 mg/l Cl ₂ 142D-G: 0.01 to 5 mg/l Cl ₂ (A and G, at 77°F, pH 7.2)
Temperature	41 to 113°F	CCS140: 50 to 113°F CCS141: 36 to 113°F	CCS240/241: 36 to 113°F	32 to 113°F
pH value range	5.5 to 9.5 pH	CCS140: 4 to 8 pH CCS141: 4 to 8.2 pH	CCS240/241: in stability range of ClO ₂	CCS142D-A: 4 to 8 pH CCS142D-G: 4 to 8.2 pH
Temperature sensor	Integrated NTC	Integrated NTC	Integrated NTC	
Maximum back pressure	14.5 psig	14.5 psig	14.5 psig	14.5 psig
Installation	CCA250 flow holder	CCA250 flow holder	CCA250 flow holder	CCA250 flow holder, CYH112
Sensor cable	4-wire, 15 ft, double-shielded	4-wire, 15 ft, double-shielded	4-wire, 15 ft, double-shielded	CYK10 Memosens® cable
Transmitter	Liquisys M CGM223/253	Liquisys M CGM223/253	Liquisys M CGM223/253	Liquiline® CM44, CM330

Chlorine Flow Holder Assemblies	
	Flowfit W CCA250 
Application	Drinking, industrial water
Description	Flow assembly designed to hold chlorine or chlorine dioxide sensors for measurement of free chlorine and chlorine dioxide
Material	Plexiglass (PMMA), PVC, 316Ti SS
Maximum pressure	14 psig with sensors at 104°F
Maximum temperature	113°F
Measured water flow	7 to 30 gal/hr, adjustable needle valve
Sensor connection	Two Pg 13.5 for pH and/or ORP electrodes (120 mm only) One internal threaded connection for CCS series electrode



Moldular Holder Assemblies		
	Flexdip CYH112	Flexdip CYA112
		
Application	Water and wastewater	Water and wastewater
Description	Single installation point, flexible holder system: for floor, wall or rail mounting	Standard immersion pipe, chain immersion pipe or floater immersion pipe
Area of use	Basins, open channels, open tanks, process vats	Basins, open channels, open tanks, process vats
Sensor installation	Cantilever arm with chain, fixed immersion pipe, free swinging or float-lever version for varying levels	Various sensor connection threads or chain mount adapter. Straight or 45° angle mounting
Compatible sensor holder assemblies	Flexdip CYA112, Dipfit W CLA111, Dipfit W CPA111	Flexdip CYH112
Material	Stainless steel and plastic	Stainless steel and PVC
Ambient temperature	-4 to +140°F	-4 to +140°F
Main pipe height	20", 40", 71"	Lengths vary depending on application
Cantilever arm length	20", 40", 59"	N/A



Chlorine Transmitters		
	Liquisys M CCM223/253 	Liquiline® CM442/CM444/CM448 Digital Memosens® Transmitter 
Application	Drinking water, cooling water, food processing	Water/wastewater, power, chemical, process industries
Measurement type	Chlorine/chlorine dioxide 4-wire transmitter 1 or 2 measuring circuits, 2 or 4 relays Measures pH and temperature	Memosens® transmitter for pH, ORP, conductivity, dissolved oxygen, turbidity, nitrate, chlorine
Measurement range	CCS140/240: 0.05 to 20 ppm CCS141/241: 0.01 to 5 ppm Temperature: 35 to 110°F	Dependent on sensor type
Output	0/4 to 20 mA, 15 VDC (digital)	Up to 8, 4-20 mA, up to 4, SPDT relays Automatic clean and calibration functions
Input	4 to 20 mA, 10 to 50 V (digital)	1 to 8 digital Memosens® sensors (Memosens® sensors only)
Power supply	100/115/230 VAC 24 VAC/VDC	100 to 230 VAC 24 VAC 24 VDC
Ambient temperature	14 to 131°F	-4 to +140°F
Mounting	Wall, pipe, panel mount (CPM223)	Wall, pipe, panel mount
Operation	Via push buttons and dot matrix LCD display, HART® or Profibus®	Via soft keys, LCD display, and navigator; Integration into FieldCare® and W@M asset management
Housing	Field housing: ABS PC Fr, polyester front Panel mount: Polycarbonate, polyester front	Polycarbonate plastic housing
Approvals / certificates	CSA general purpose	FM/CSA = CM442 only (Cl I, Div. 2) CE, cCSAus



Compact Chlorine Measuring Station	
	CCE10 
Application	Drinking water, industrial water, swimming pool water - chlorine dosing in water treatment
Description	Factory assembled panel for measurement of free chlorine, chlorine dioxide or total chlorine as well as pH and temperature
Sensors	Analog sensors for free chlorine and pH
Sensor holder	Flowfit CCA250 assembly
Transmitter	Liquisys M CCM253
Measurement range	Dependent on sensor specified
Output	0/4 to 20 mA, active
Power supply	110/115/230 VAC 24 V AC/DC
Ambient temperature	32 to 120°F
Process pressure	Maximum 58 psi at 104°F
Flow rate	7.9 to 31.7 gal/h, adjustable Optimum: 7.9 gal/h
Operation	Via push button and dot matrix LCD display, HART®, Profibus® PA/DP
Approvals / certificates	CSA general purpose



Compact Chlorine System	
	CCE1 / CCE3 
Application	Drinking water, industrial water, swimming pool water
Description	Factory assembled panel for simple measurement of free chlorine, pH, ORP value and temperature. Assembled and wired panel includes installed tubing, dirt-trap, sampling cock for DPD calibration sample. Check valve and various connectors plus CCA250 flow assembly. Transmitter, sensors and cable ordered separately depending on application requirements.

Analysis Dissolved Oxygen





Dissolved Oxygen Sensors		
	Oxymax W COS31` 	Oxymax W COS41 
Application	Water, wastewater, fish farming	Water, wastewater, fish farming
Parameter	Dissolved oxygen	Dissolved oxygen
Material	316 Ti SS, POM membrane cap	POM
Measuring range	0.05 to 60 ppm	0.05 to 20 ppm
Temperature sensor	Integrated NTC	Integrated NTC
Ambient temperature	-5 to +50°C (20 to 120°F)	-5 to +50°C (20 to 120°F)
Process temperature	-5 to +50°C (20 to 120°F)	-5 to +50°C (20 to 120°F)
Process pressure	0 to 10 bar (145 psi)	0 to 10 bar (145 psi)
Process connection	¾" or G1" thread	¾" or G1" thread
Installation type	Submersible, optional accessories available for flow through and insertion installations	Submersible, optional accessories available for flow through and insertion installations
Sensor cable	Fixed or TOP 68 connector	Fixed or TOP 68 connector
Transmitter	Liquisys M COM223/253	Liquisys M COM223/253

Dissolved Oxygen Sensors			
	Oxymax COS22 COS22D Digital sensor 	Oxymax W COS51D Digital sensor 	Oxymax W COS61, COS61D Digital sensor (Optical sensor) 
Application	Food and beverage, life sciences, power	Water, wastewater, fish farming	Water, wastewater, fish farming
Parameter	Sterilizable amperometric dissolved oxygen	Amperometric dissolved oxygen	Optical (luminescence/fluorescence) dissolved oxygen
Material	316L SS, Silicone membrane cap (FDA), PTFE, steel mesh	POM	316 Ti SS, POM, Silicon (fluorescence layer)
Measuring range	0 to 100 ppb (trace version only) 0.01 to 60 mg/L 0 to 600% saturation 0 to 1200 hPa 0 to 25 Vol% (gaseous oxygen)	0.01 to 100 ppm 0.00 to 100% saturation 0 to 2000 hPa	0 to 20 ppm 0 to 200% saturation 0 to 400 hPa
Temperature sensor	Integrated NTC	Integrated NTC	Integrated NTC
Ambient temperature	-5 to +135°C (23 to 175°F)	-5 to +50°C (20 to 120°F)	-20 to +60°C (0 to 140°F)
Process temperature	-5 to +135°C (23 to 175°F)	-5 to +50°C (20 to 120°F)	-5 to +60°C (20 to 140°F)
Process pressure	12 bar (174 psi)	0 to 10 bar (145 psi)	0 to 10 bar (145 psi)
Shaft length	120, 225, 360, 420 mm	N/A	N/A
Process connection	PG 13.5 thread	Combination ¾" MNPT and G1" thread	COS61: G1" thread COS61D: Combination ¾" MNPT and G1" thread
Sensor cable	COK21 (COS22), CYK10 (22D)	CYK10	COS61: Fixed cable or TOP68 with CYK71 cable COS61D: Fixed cable
Transmitter	COS22: Liquisys M COM223F/COM253F COS22D: Liquiline® CM42, CM442/444/448 and CM442R/444R/448R	Liquiline® CM42, CM442/444/448 and CM442R/444R/448R	COS61: Liquisys M COM223/253 COS61D: Liquiline® CM442/444/448 and CM442R/444R/448R



Dissolved Oxygen Holder Assemblies		
	Flowfit W COA250	Cleanfit COA451
		
Application	Water, wastewater	Water, wastewater
Description	Flow assembly designed for bypass system, for dissolved oxygen sensor COS31 or COS41 and 1 CUR 3 cleaner spray head	Manually operated SS holder assembly with ball valve and rinse connections, designed to hold COS31 or COS41
Material	PVC	316L SS
Maximum pressure	87 psi at 68°F	145 psi (29 psi for manual operation)
Maximum temperature	122°F	32 to 122°F
Flow rate	26 to 260 gal/hr	N/A, must be constant flow
Sensor connection	Threaded mounting sleeve with union nut	Internal, with sensor external threads
Holder installation	Bypass line	Weld neck, 2" Class 150 ANSI flange

Modular Holder Assemblies		
	Flexdip CYH112	Flexdip CYA112
		
Application	Water and wastewater	Water and wastewater
Description	Single installation point, flexible holder system: for floor, wall or rail mounting	Standard immersion pipe, chain immersion pipe or floater immersion pipe
Area of use	Basins, open channels, open tanks, process vats	Basins, open channels, open tanks, process vats
Sensor installation	Cantilever arm with chain, fixed immersion pipe, free swinging or float-lever version for varying levels	Various sensor connection threads or chain mount adapter. Straight or 45° angle mounting
Compatible sensor holder assemblies	Flexdip CYA112, Dipfit W CLA111, Dipfit W CPA111	Flexdip CYH112
Material	Stainless steel and plastic	Stainless steel and PVC
Ambient temperature	-4 to +140°F	-4 to +140°F
Main pipe height	20", 40", 71"	Lengths vary depending on application
Cantilever arm length	20", 40", 59"	N/A



NOTE: Other holder assemblies are available, refer to pH holder information for CPA240, CPA450, CPA475, CPA442.

Dissolved Oxygen and Multi Parameter Transmitters				
	Liquisys M COM223/253	Liquisys M COM223F/253F	Liquiline® CM42	Liquiline® CM442/444/448 and CMR442R/444R/448R multi-parameter Memosens® technology transmitter
				
Application	Water, wastewater	Food and pharmaceutical	Chemical, pharmaceutical, food, water	Water/wastewater, power, chemical, process industries
Measurement type	Dissolved oxygen 4-wire transmitter 1 or 2 measuring circuits, 2 or 4 relays Measures O ₂ and temperature	Dissolved oxygen 4-wire transmitter 1 or 2 measuring circuits, 2 or 4 relays Measures O ₂ and temperature	2-wire transmitter for pH, ORP, conductivity, dissolved oxygen, concentration	Universal, multi-parameter transmitter for all Memosens® and Memosens technology digital sensors including pH, ORP, pH/ORP/rH, conductivity, dissolved oxygen, turbidity/TSS, nitrate, ammonium, SAC/UV254, and chlorine
Measurement range	O ₂ measurement: 0.05 to 60 ppm or 0 to 200% saturation Temperature: 14 to 140°F	O ₂ measurement: 0.1 to 20 ppm or 0 to 200% saturation Temperature: 14 to 140°F	0.0 to 100.0 ppm, 0 to 1000% saturation, 0 to 2000 hPa Temperature: -10 to +300°F	Measurement range and parameters defined by each connected sensor specification
Output	0/4 to 20 mA, Profibus® PA, Profibus® DP, HART®, relays	0/4 to 20 mA, 15 VDC (digital)	1 x 4 to 20 mA + HART®, 2 x 4 to 20 mA + HART®, Profibus PA®, Foundation™ Fieldbus	Two to eight 0/4 to 20 mA outputs. Digital Fieldbuses (HART®, PROFIBUS®, Modbus TCP/485), integrated web server, from one to nine SPDT relays are possible depending on configuration
Input	4 to 20 mA, 10 to 50 V (digital)	4 to 20 mA, 10 to 50 V (digital)	Digital sensor: All Memosens® sensors and Memosens technology inductive conductivity sensors Analog sensors: pH, differential pH, IsFET pH, ORP, two and four electrode conductivity/resistivity, and inductive conductivity/concentration	1 to 8 Memosens® & Memosens® technology sensors with optional analog 4-20 transmitter and digital input capability
Power supply	100/115/230 VAC 24 VAC/VDC	100/115/230 VAC 24 VAC/VDC	12.5 to 30 VDC; Profibus® or fieldbus 9 to 32 VDC (non-hazardous) or 9 to 17.5 VDC (hazardous)	100 to 240 VAC, 50/60 cycle 24 VAC (CM442 and CM442R only) 24 VDC
Ambient temperature	14 to 131°F	14 to 131°F	-20 to +175°F	-4 to +140°F
Mounting	Wall, pipe, panel mount (CPM223)	Wall, pipe, panel mount (CPM223F)	Wall, pipe, panel mount	CM442/444/448: Wall or pipe CM442R/444R/448R: DIN rail mount with optional remote panel mount display
Operation	Via push buttons and dot matrix LCD display, HART® or Profibus®	Via push buttons and dot matrix LCD display, HART® or Profibus®	Via soft keys, LCD display, and navigator HART®, Profibus® PA, and FOUNDATION™ Fieldbus	Via local or remote (CM44xR only) LCD display w/soft keys and Navigator; via IP Addressable Webserver, integrated into FieldCare®, Field Data Manager and W@M asset management
Housing	Field housing: ABS PC Fr, polyester front Panel mount: Polycarbonate, polyester front	Field housing: ABS PC Fr, polyester front Panel mount: Polycarbonate, polyester front	Polycarbonate plastic housing or 304 SS housing	CM442/444/448: NEMA4X polycarbonate housing CM442R/444R/448R: Open, DIN rail mount for mounting inside a cabinet
Approvals / certificates	CSA general purpose	CSA general purpose	CE, FM, CSA, SIL 2	CE/uCSAc and FM (available for CM442 only)

Analysis Turbidity



Turbidity Sensors			
	Turbimax W CUS31	Turbimax W CUS41	Turbimax CUS51D with Memosens®
			
Application	Drinking water, industrial water	Water, wastewater	Water, wastewater
Parameter	Turbidity	Turbidity	Turbidity and Total Suspended Solids (TSS)
Measurement method	90° scattered light, 880 nm	90° scattered light, 880 nm	90° and 135° back-scatter, 4-beam pulsed light, 860 nm LED
Material	PVC, sapphire optical window	PVC, sapphire optical window	316L SS, sapphire optical window
Measuring range	0.000 to 9999 FNU 0.00 to 3000 ppm 0.0 to 3.0 g/l 0.0 to 200%	0.00 to 9999 FNU 0.00 to 9999 ppm 0.0 to 300 g/l 0.0 to 200.0%	C1 version: Turbidity: 0 to 4000 FNU Solids content: 0 to 4 g/l D1 version: Turbidity: 0 to 4000 FNU Solids: 0 to 300 g/L, 0 to 30%
Temperature sensor	Integrated NTC	Integrated NTC	N/A
Ambient temperature	23 to 122°F	23 to 122°F	-4 to +140°F
Process temperature	23 to 122°F	23 to 122°F	23 to 120°F
Process pressure	14.5 psi at 122°F, 87 psi at 77°F	14.5 psi at 122°F, 87 psi at 77°F	0.5 to 10 bar (7 to 145 psia)
Process connection	Combination ¾" MNPT and G1" thread	Combination ¾" MNPT and G1" thread	Combination ¾" MNPT and G1" thread
Installation type	Submersible, optional accessories available for flow through and insertion installations	Submersible, optional accessories available for flow through and insertion installations	Submersible, optional accessories available for flow through and insertion installations
Sensor cable	Fixed	Fixed	Fixed
Transmitter	Liquisys M CUM223/253	Liquisys M CUM223/253	Liquiline® CM442/444/448 or CM442R/444R/448R



Turbidity Sensor	
	Turbimax CUS71D with Memosens® 
Application	Water, wastewater
Parameter	Submersed Ultrasonic Interface Level Sensor
Measurement method	Ultrasonic
Material	ABS and epoxy plastic, rubber wiper
Measuring range	1.0 to 32 ft 0 to 50 NTU
Process temperature	34 to 122°F
Process pressure	0 to 87 psi
Process connection	Combination ¾" MNPT and G1" thread
Immersion depth	Submersible
Sensor cable	Fixed
Transmitter	Liquiline® CM442/444/448 or CM442R/444R/448R

Turbidity Holder Assemblies		
	Flowfit W CUA120/250	Cleanfit CUA451
		
Application	Water, wastewater	Water, wastewater
Description	Flow assembly designed for bypass system, for turbidity sensor CUS31 or CUS41 and one CUR3 cleaner spray head	Manually operated SS holder assembly with ball valve and rinse connections, designed to hold CUS31, CUS41, or CUS65
Material	PVC	316L SS
Maximum pressure	90 psi at 77°F, 15 psi at 122°F	145 psi (29 psi for manual operation)
Maximum temperature	122°F	32 to 122°F
Flow rate	Constant	Constant flow
Sensor connection	Threaded mounting sleeve with union nut	Internal, with sensor external threads
Holder installation	Bypass line	Weld neck, 2" Class 150 ANSI flange

Turbidity Transmitters	
	<p>Liquisys M CUM223/253</p> 
Application	Water, wastewater
Measurement type	Turbidity/suspended solids 4-wire transmitter, 2 or 4 relays, measures turbidity and temperature
Measurement range	Temperature: -5.0 to +70.0 °C (+23 to +158 °F) CUS31: 0.000 to 9999 FNU/NTU 0.00 to 3000 ppm 0.0 to 3.0 g/l 0.0 to 200.0% CUS41: 0.00 to 9999 FNU/NTU 0.00 to 9999 ppm 0.0 to 300.0 g/l 0.0 to 200.0%
Output	0/4 to 20 mA, Profibus® PA, Profibus® DP, HART®, relays
Input	4 to 20 mA, 10 to 50 V (digital) CUS31, CUS41 sensors
Power supply	100/115/230 VAC 24 VAC/VDC
Ambient temperature	14 to 131°F
Mounting	Wall, pipe, panel mount (CPM223)
Operation	Via push buttons and dot matrix LCD display, HART® or Profibus®
Housing	Field housing: ABS PC Fr, polyester front Panel mount: Polycarbonate, polyester front
Approvals / certificates	CSA general purpose







Multi-Parameter Memosens® Technology	
	<p>Liquiline CM442/444/448 and CM442R/CM444R/CM448R Multi-parameter Memosens® Technology Transmitter</p> 
Application	Water, wastewater, power, chemical, process industries
Measurement type	Universal, multi-parameter transmitter for all Memosens® and Memosens technology digital sensors including pH, ORP, pH/ORP/rH, conductivity, dissolved oxygen, turbidity/TSS, nitrate, ammonium, SAC/UV254, and chlorine
Measurement range	Measurement range and parameters defined by each connected sensor specification
Output	Two to eight 0/4 to 20 mA outputs. Digital Fieldbuses (HART®, PROFIBUS®, Modbus TCP/485), integrated web server, from one to nine SPDT relays are possible depending on configuration
Input	1 to 8 Memosens® & Memosens® technology sensors with optional analog 4-20 transmitter and digital input capability
Power supply	100 to 240VAC, 50/60 cycle 24 VAC (CM442 and CM442R only) 24 VDC
Ambient temperature	-4 to +140°F
Mounting	CM442/444/448: Wall or pipe CM442R/444R/448R: DIN rail mount with optional remote panel mount display
Operation	Via local or remote (CM44xR only) LCD display w/soft keys and Navigator; via IP Addressable Webserver, integrated into FieldCare®, Field Data Manager and W@M asset management
Housing	CM442/444/448: NEMA4X polycarbonate housing CM442R/444R/448R: Open, DIN rail mount for mounting inside a cabinet
Approvals / certificates	CM442/444/448: NEMA4X polycarbonate housing CM442R/444R/448R: Open, DIN rail mount for mounting inside a cabinet







Moldular Holder Assemblies		
	<p>Flexdip CYH112</p> 	<p>Flexdip CYA112</p> 
Application	Water and wastewater	Water and wastewater
Description	Single installation point, flexible holder system: for floor, wall or rail mounting	Standard immersion pipe, chain immersion pipe or float immersion pipe
Area of use	Basins, open channels, open tanks, process vats	Basins, open channels, open tanks, process vats
Sensor installation	Cantilever arm with chain, fixed immersion pipe, free swinging or float-lever version for varying levels	Various sensor connection threads or chain mount adapter. Straight or 45° angle mounting
Compatible sensor holder assemblies	Flexdip CYA112, Dipfit W CLA111, Dipfit W CPA111	Flexdip CYH112
Material	Stainless steel and plastic	Stainless steel and PVC
Ambient temperature	-4 to +140°F	-4 to +140°F
Main pipe height	20", 40", 71"	Lengths vary depending on application
Cantilever arm length	20", 40", 59"	N/A

Turbidity Meters			
	Turbimax CUE21/22	Turbimax CUE23/24	Turbimax CUE25/26
			
Application	Water, treated process water (in-line continuous measurement)	Water, process water, wastewater (laboratory measurement)	Water, process water, wastewater (handheld field measurement)
Parameter	Turbidity	Turbidity	Turbidity
Measurement method	90° scattered light CUE21, IR light, 860 nm CUE22, white light per US EPA 180.1	90° scattered light CUE23, IR light, 860 nm CUE24, white light per US EPA 180.1	90° scattered light CUE25, IR light, 860 nm CUE26, white light per US EPA 180.1
Measuring range	0 to 1000 NTU	0 to 1000 NTU	0.01 to 1100 NTU
Output	4 to 20 mA Two relays	RS232, unidirectional	N/A
Power supply	100 to 240 VAC	12 VDC (adaptable to 100 to 240 VAC)	4 AAA alkaline batteries
Ambient temperature	34 to 122°F	50 to 104°F	32 to 122°F
Process pressure	Max. 200 psi	N/A	N/A
Sample holder	Glass cuvette, flow-through	Glass cuvette	Glass cuvette
Operation	Four keys, LCD (backlit)	Four keys, LCD (backlit)	Four keys, LCD
Communication	RS485, optional Modbus	RS232	N/A
Approvals	CE, ETL (UL3111-1)	CE, ETL (UL3101-1)	CE

Compact Turbidity Measuring Station	
	CUE31 
Application	Drinking water, filter backwash, spring water, pool water
Description	Factory assembled panel for simple measurement of water with turbidity levels <1 FNU. Assembled and wired panel includes installed tubing, inlet and outlet with stop cocks for flow regulation, and drain. Complete with flow through holder with CUS31 turbidity sensor, Liquisys CUM253 transmitter with one current output and two relays.

Analysis Wastewater



Analyzer systems						
	Stamolys CA71 AM Ammonium	Stamolys CA71 CL Chlorine	Stamolys CA71 NO Nitrite	Stamolys CA71 PH Phosphate	Stamolys CA71 AL Aluminum	Stamolys CA71 CR Chromate
						
Application	Sewage treatment	Water, wastewater	Water, wastewater	Sewage treatment	Water, wastewater	Industrial water
Measurement type	Photometric	Photometric	Photometric	Photometric	Photometric	Photometric
Input	NH ₄ -N (ppm)	Cl ₂ (ppm) free or total	NO ₂ -1N (ppm)	PO ₄ -P (ppm)	Al (ppm)	Cr (ppm)
Measuring range	0-2 to 5 ppm 0.2 to 15 ppm 0.2 to 100 ppm	0.01 to 1.00 ppm 0.10 to 10.00 ppm	10 to 500 µppm 0.10 to 1.00 ppm 0.20 to 3.00 ppm .01-250 µppm (ppb)	0.05-2.5 mg/l 0.5-20 mg/l 0.5-50 mg/l 0.05-10 mg/l	10 to 300 µppm 50 to 1000 µppm	0.10 to 2.50 ppm 0.20 to 5.00 ppm
Output	0/4 to 20 mA	0/4 to 20 mA	0/4 to 20 mA	0/4 to 20 mA	0/4 to 20 mA	0/4 to 20 mA
Power supply	115/230 VAC	115/230 VAC	115/230 VAC	115/230 VAC	115/230 VAC	115/230 VAC
Ambient temperature	41 to 104°F	41 to 104°F	41 to 104°F	41 to 104°F	41 to 104°F	41 to 104°F
Operation	Via push buttons, LED display, LCD display, RS232	Via push buttons, LED display, LCD display, RS232	Via push buttons, LED display, LCD display, RS232	Via push buttons, LED display, LCD display, RS232	Via push buttons, LED display, LCD display, RS232	Via push buttons, LED display, LCD display, RS232
Housing	304 SS with plexiglass window or GFK plastic	304 SS with plexiglass window or GFK plastic	304 SS with plexiglass window or GFK plastic	304 SS with plexiglass window or GFK plastic	304 SS with plexiglass window or GFK plastic	304 SS with plexiglass window or GFK plastic
Approvals / certificates	CE	CE	CE	CE	CE	CE



Analyzer systems						
	Stamolys CA71 CU Copper	Stamolys CA71 FE Iron	Stamolys CA71 HA Hardness	Stamolys CA71 HY Hydrazine	Stamolys CA71 MN Manganese	Stamolys CA71 SI Silicate
						
Application	Industrial sewage, process	Water, wastewater	Drinking water	Cooling, boiler feed water	Water, wastewater	Industrial water
Measurement type	Photometric	Photometric	Photometric	Photometric	Photometric	Photometric
Input	CU (II) (ppm)	Fe (ppm)	CaCO ₃ (ppm)	N ₂ H ₄ (ppm)	Mn (ppm)	SiO ₂ (ppm)
Measuring range	0.10 to 2.00 ppm 0.20 to 5.00 ppm	10 to 500 µppm 0.05 to 2.00 ppm 0.10 to 5.00 ppm 2-250 µppm (ppb)	0.01 to 10 ppm 0.8 to 80 ppm	1 to 500 µppm	1 to 150 µppm 0 to 2000 µppm	1 to 200 µppm 0.01 to 5.00 ppm
Output	0/4 to 20 mA	0/4 to 20 mA	0/4 to 20 mA	0/4 to 20 mA	0/4 to 20 mA	0/4 to 20 mA
Power supply	115/230 VAC	115/230 VAC	115/230 VAC	115/230 VAC	115/230 VAC	115/230 VAC
Ambient temperature	41 to 104°F	41 to 104°F	41 to 104°F	41 to 104°F	41 to 104°F	41 to 104°F
Operation	Via push buttons, LED display, LCD display, RS232	Via push buttons, LED display, LCD display, RS232	Via push buttons, LED display, LCD display, RS232	Via push buttons, LED display, LCD display, RS232	Via push buttons, LED display, LCD display, RS232	Via push buttons, LED display, LCD display, RS232
Housing	304 SS with plexiglass window or GFK plastic	304 SS with plexiglass window or GFK plastic	304 SS with plexiglass window or GFK plastic	304 SS with plexiglass window or GFK plastic	304 SS with plexiglass window or GFK plastic	304 SS with plexiglass window or GFK plastic
Approvals / certificates	CE	CE	CE	CE	CE	CE



Wastewater nitrate, ammonium, etc	
	ISEmax CAS40D sensor 
Application	Wastewater
Measurement type	Ion-selective electrode system
Input	Ammonium, nitrate, potassium, chloride, pH
Measurement range	0.1 to 1000 mg/l NH ₃ -N 0.1 to 1000 mg/l NO ₃ -N 1 to 1000 mg/l potassium 1 to 1000 mg/l chloride
Ambient temperature	-4 to +120°F
Process temperature	36 to 100°F, max 6 psi
Sensor	PVC, glass, polyethylene (wetted parts dependent on electrodes used), O-rings EPDM
Sensor cable	328 feet maximum
Sensor power supply	Liquiline® CM442 transmitter
Sensor mounting	Upright post with boom (CYH112 / CYA112)
Approvals /certificates	CE

Water/Wastewater transmitter	
	Liquiline® CM442 Digital Memosens® Transmitter 
Application	Water/wastewater, power, chemical, process industries
Measurement type	Memosens transmitter for pH, ORP, conductivity, dissolved oxygen, turbidity, nitrate (CAS51D and ISEmax CAS40D)
Measurement range	Dependent on sensor type
Output	2 or 4 4 to 20 mA, 1 or 2 SPDT relays Automatic clean and calibration functions
Input	1 or 2 digital Memosens sensors (Memosens sensors only)
Power supply	100 to 230 VAC 24 VAC 24 VDC
Ambient temperature	-4 to +140°F
Mounting	Wall, pipe, panel mount
Operation	Via soft keys, LCD display, and navigator; Integration into FieldCare and W@M asset management
Housing	Polycarbonate plastic housing
Approvals / certificates	CE, FM, Class 1, Div 2 with pH, Conductivity, and Amperometric Dissolved Oxygen

Photometric nitrate sensor	
	Viomax CAS51D with Memosens 
Application	Wastewater
Parameter	Nitrate
Material	316L SS, quartz glass, EPDM O-rings
Measuring range	2 mm gap, 0.1 to 50 mg/l NO ₃ -N Clear water + activated sludge 0.01 to 20 mg/l, 0.01 to 10 mg/l NO ₃ -N Clear water
Ambient temperature	-4 to +140°F
Process temperature	41 to 120°F
Process pressure	7 to 145 psia
Insertion depth	Cuvette gap, must be submerged
Process connection	¾" NPT, G1
Sensor cable	Fixed, Memosens, maximum 328 ft
Power	Provided by Liquiline CM442
Approvals	Non-hazardous

Modular Holder Assemblies		
	Flexdip CYH112	Flexdip CYA112
		
Application	Water and wastewater	Water and wastewater
Description	Single installation point, flexible holder system: for floor, wall or rail mounting	Standard immersion pipe, chain immersion pipe or floater immersion pipe
Area of use	Basins, open channels, open tanks, process vats	Basins, open channels, open tanks, process vats
Sensor installation	Cantilever arm with chain, fixed immersion pipe, free swinging or float-lever version for varying levels	Various sensor connection threads or chain mount adapter. Straight or 45° angle mounting
Compatible sensor holder assemblies	Flexdip CYA112, Dipfit W CLA111, Dipfit W CPA111, ISEmax CAS40D	Flexdip CYH112
Material	Stainless steel and plastic	Stainless steel and PVC
Ambient temperature	-4 to +140°F	-4 to +140°F
Main pipe height	20", 40", 71"	Lengths vary depending on application
Cantilever arm length	20", 40", 59"	N/A

Water/Wastewater Sampler Systems		
	Liquistation CSF48 Stationary sampler 	Liquiport CSP44 Portable sampler 
Application	Water/Wastewater	Water/Wastewater
Online measurement available with sampler	Nitrate, Conductivity, Oxygen, pH/ORP, Turbidity	Nitrate, Conductivity, Oxygen, pH/ORP, Turbidity
Input	2 analog input, 0/4 to 20 mA 2 binary inputs (passive), 12 to 30 V 1 or 2 digital inputs (Memosens protocol)	2 analog input, 0/4 to 20 mA 2 binary inputs (passive), 12 to 30 V 1 or 2 digital inputs (Memosens protocol)
Temperature input	Pt1000, -20 to +160°F measuring range	Pt1000, 20 to +160°F measuring range
Measurement range	-20 to +160°F	Dependent on connected sensor
Output	2 Binary Outputs Standars, 2 Binary Outputs optional Open Collector, max 30 V, 200 mA Depending on the version selected: 1 x 0/4-20 mA, active, selectable with HART 2 x 0/4-20 mA active 4 x 0/4-20 mA active 6x 0/4- 20 mA active Profibus DP MODBUS 485 Ethernet and Modbus TCP	2 binary, open collector, 30V, 200 mA 2 x 0/4 to 20 mA (optional)
Power supply	100 to 240 VAC 24 VDC	24 VDC, 7.2 Ah lead-acid battery Charger, 90 to 265 VAC
Ambient temperature	-4 to +100°F with temperature control unit 32 to 100°F without temperature control unit	32 to 100°F
Process temperature	36 to 122°F	36 to 122°F
Process pressure	Unpressurized, open channel (unpressurized sampling) Maximum 11.6 psi piping (pressurized sampling) Maximum 87 psi with Sampling Assembly Model CSA240	Unpressurized
Sampling method	Vacuum pump Peristaltic pump	Peristaltic pump
Suction line	Plastic PVC or EPDM, maximum 26 foot suction height	Plastic PVC or EPDM, maximum 26 foot suction height
Sample containers	Various sizes and combinations available from 1 liter (24 containers) to 60 liter (1 container), containers made of PE or glass depending on application	Various sizes and combinations available from 1 liter (24 containers) to 20 liter (1 container), containers made of PE or glass depending on application
Transmitter	Liquiline CM442	Liquiline CM442
Operation	Via 4 soft keys, LCD display and navigator	Via 4 soft keys, LCD display and navigator
Software	Field Data Manager, FieldCare	Field Data Manager, FieldCare
Approvals / certificates	CE	CE



Backwash and filter systems		Micro filter	
	Stamoclean CAT430 	Stamoclean CAT221 	Stamoclean CAT411 Micro filter 
Application	Wastewater, activated sludge basins	Wastewater (inlet or outlet)	Wastewater, industrial water
System type	Micro/ultra filtration system	Self-cleaning backwash filter	Self-cleaning cross flow filter
Filtration volume	With hose pump: 0.06 gal/h per filter With diaphragm pump: 0.12 gal/hr per filter	2.6 gal/hr	3.5 to 8 gpm, 8 to 18 ft/s flow rate, 3 to 14.5 psi
Sample distance range	With hose pump: 65 ft With diaphragm pump: 328 ft	N/A	N/A
Power supply	115/230 VAC	115/230 VAC 24 VDC	N/A
Ambient temperature	14 to 122°F	32 to 122°F	N/A
Sample temperature	41 to 122°F	41 to 104°F, 2.9 to 58 psi	41 to 122°F
Analyzer type	Any CA71 Stamolys analyzer (purchased separately)	Any CA71 Stamolys analyzer (purchased separately)	Any CA71 Stamolys analyzer (purchased separately)
Mounting	Filter element holders: 304 SS Mounting square pipe: 304 SS	Field mounting plate, PVC Housing, GFK (fiberglass reinforced)	Field mounting plate, PVC Housing, GFK (fiberglass reinforced)
Operation	Via push buttons, LED indicators, cycle timer	LCD display, two control push buttons	N/A
Approvals/certificates	CE	General purpose	General purpose

Analysis, Water/Wastewater

Analyzer, TOC	
CA72 TOC 	
Application	Industrial and municipal wastewater treatment
Analyzer function	Continuous TOC measurement
Analyzer type	Catalytic, high temperature oxidation
Measurement range	2 to 50,000 mg/l TOC
Detection limit	2 mg/l TOC with IR detector 500 ppm
Response time	7 minutes
Output	0/4 to 20 mA selectable Dry contact relay for high, low limit and slope Dry contact relay fault signal
Power supply	0 to 230 VAC
Display/local operation	16 line, 40 characters, backlit LCD graphics display 21 key operation, RS232C for data output
Data presentation	6-hour graphic (14 day scrollable); current value with 5-digit resolution
Monitoring	Warning logs, malfunctions, limit value alarms and calibration for previous 4 weeks, leakage alerts, defective probe, general errors for measuring cell, dilution water failure
Data storage	14 days in RAM; 90 days with diskette drive
Ambient temperature	40 to 104°F
Sample handling	Bypass sampler with prep and self-cleaning coarse filter
Sample flow rate	0.1 to 35 GPM depending on sample bypass system

Analyzer, P_{Total}	
CA72P Analyzer 	
Application	Industrial and municipal wastewater treatment
Analyzer function	Continuous measurement of total phosphorus
Analyzer type	Thermal digestion with colorimetric detection
Measurement range	.05-2 mg/l 0.1-5 mg/l 0.3-8 mg/l 0.5-25 mg/l
Detection limit	0.1 mg/l P _{Total} (with 20 mm path length)
Response time	12 minutes excluding sample prep
Measurement cycle	Minimum 6 minutes
Output	0/4 to 20 mA selectable Dry contact relay for high, low limit and slope Dry contact relay fault signal
Power supply	115 VAC or 230 VAC
Display / local operation	16 line, 40 characters, backlit LCD graphics display 21 key operation, RS232C for data output
Data presentation	6-hour graphic (14 day scrollable); current value with 5-digit resolution
Monitoring	Warning logs, malfunctions, limit value alarms and calibration for previous 4 weeks, leakage alerts, defective probe, general errors for measuring cell, dilution water failure
Data storage	14 days in RAM; 90 days with diskette drive
Ambient temperature	40 to 104°F
Sample handling	Bypass sampler with prep and self-cleaning coarse filter
Sample flow rate	0.1 to 35 GPM depending on sample bypass system

Analysis, Optical

Concentration and Color Sensors		
	Model OUSAF21 Flow through optical	Model OUSAF22 Flow through optical
		
Transmitter type	Memograph M CVM40 or Model 980	Memograph M CVM40 or Model 980
Application	Potable water	Potable water
Sensor type	Low level color	Dual beam color
Measurement wavelength	390 to 1100 nm	390 to 1100 nm
Path length	100 to 250 mm	0.5 to 100 mm
Lamp	4 watt incandescent, rated for FM Class I, Div. 1, Grps. B, C, D	4 watt incandescent, rated for FM Class I, Div. 1, Grps. B, C, D
Output	Low level current	Low level current
Window material	Pyrex, fire polished quartz, or sapphire	Pyrex, fire polished quartz, or sapphire
Maximum temperature	194°F; with PEEK isolators, 266°F	194°F; with PEEK isolators, 266°F
Maximum pressure	500 psig dependent on material, line size and process connection	3000 psig dependent on material, line size and process connection
Process connection	¾" FNPT	Tri-clamp®, flange, FNPT
Sensor material	316 SS	316 SS



Cell Density Sensor	
	OUSBT66 Optical insertion
	
Transmitter type	Memograph M CVM40
Application	Bacterial fermentation, mammalian cell culture
Sensor type	Optical insertion probe
Measurement wavelength	Broadband NIR absorption, 880 nm
Measurement range	0 to 4 AU, 0 to 8 OD (depending on optical path length)
Path length	5, 10 or 20 mm
Lamp	4 watt incandescent
Output	Low level current
Window material	Sapphire
Detector type	Solid state silicon photodetector
Process temperature	32 to 158°F, up to 275°F when lamp is switched off
Maximum pressure	150 psig
Process connection	Threaded, PG13.5
Sensor material	316L SS
Sensor length	120 mm, 225 mm, 360 mm

Optical Transmitter	
	Memograph M CVM40
	
Recorder type	Graphic data manager, paperless Record, visualize, analyze and communicate, mathematics package
Application	Process monitoring / control
Input	Optical channels: Absorbance (UV, color, NIR, cell growth), turbidity Voltage, current, RTD, TC, pulse input, frequency input
Input types	Up to 4 optical channels for max. 2 photometric sensors, 2 universal analog channels
Outputs	1 alarm relay, 5 NO relays for limit values 0/4 to 20 mA
Plot or memory storage	Internal memory 256 MB, SD card or USB stick
Interface	Integrated WEB server, fieldbus (Profibus®, Modbus) USB, TCP/IP, OPC, Ethernet, RS232/485
Local operation	4 soft keys, 2 LEDs, navigator (jog/shuttle dial)
Display type	7" TFT display, multicolor
Ambient temperature	14 to 122°F
Power supply	100 to 230 VAC 24 V AC/DC
Approvals / certificates	CE, UL, FDA 21 CFR 11

Optical Transmitter	
	Model OUM980
	
Analyzer type	Dual beam photometer
Sensor type	OUSAF21 or OUSAF22
Input	Dual current from sensor
Range	Up to 5 AU/OD
Output	1 alarm relay, 2 process relay contacts 2 fully isolated 4 to 20 mA outputs
Power supply	100 to 250 VAC Optional 18 to 36 VDC
Ambient temperature	32 to 131°F
Display	4 x 20 character alphanumeric
Operation	Via 6 push buttons and display
Housing	Panel mount, 3.6" x 3.6"

Flow Assembly	
	OUA260
	
Application	Flow assembly for certain OUSAF sensors for the measurement of UV and NIR absorption, color and turbidity
Sensor types	OUSAF44/45/46/10/12/22 and OUSTF10
Optical path lengths	0.5 mm to 90 mm
Line sizes	¼" to 4"
Optical window materials	Pyrex, quartz, sapphire
Materials	316L SS, titanium, Hastelloy, PEEK, Kynar
O-rings	Viton, silicone, EPDM, Kalrez
Process connections	Tri-clamp, 150 lb/300 lb ANSI RF flanges, NPT female, Swagelock BVCO, Swagelock tube, tube stub
Process temperature	32 to 266°F (insure compatible with process temperature of selected sensor)
Process pressure	Up to 1450 psi depending on material, line size and process connection

Phase Separation, Chromatography Sensors

	OUSAF44 Flow through UV	OUSAF45 Flow through UV	OUSAF46 Flow through UV, dual channel
			
Transmitter type	Memograph M CVM40 or OUM960	Memograph M CVM40 or OUM960	Memograph M CVM40 or OUM960
Application	Phase separation, Chromatography	Phase separation, Chromatography	Phase separation, Chromatography
Sensor type	Spectral absorbance in UV range	Spectral absorbance in UV range	Spectral absorbance in UV range
Measurement wavelength	254 to 365 nm	204, 214 or 226 nm	254 to 365 nm
Path length	0.5 to 100 mm	0.5 to 45 nm, up to 500 nm	0.5 to 100 mm
Lamp	Low pressure mercury vapor, 4 watt FM Class I, Div. 1, Grps. B, C, D	Low voltage 4 watt incandescent FM Class I, Div. 1, Grps. B, C, D	Low pressure mercury vapor, 4 watt FM Class I, Div. 1, Grps. B, C, D
Detector type	UV enhanced silicone detector	Silicone detector	UV enhanced silicone detector
Output	Low level current	Low level current	Low level current
Window material	Fire polished quartz or sapphire	Pyrex®, Lexan®, fire polished quartz, or sapphire	Fire polished quartz or sapphire
Maximum temperature	194°F continuous; with PEEK™ isolators, 266°F	194°F continuous; 266°F for two hours	194°F continuous; with PEEK™ isolators, 266°F
Maximum pressure	3000 psig dependent on material, line size and process connection	3000 psig dependent on material, line size and process connection	3000 psig dependent on material, line size and process connection
Process connection	FNPT, Tri-clamp®, 150/300 lb flange	Tri-clamp®, 150/300 lb flange, FNPT	Tri-clamp®, 150/300 lb flange, FNPT
Sensor material	316L SS	316L SS	316L SS

Optical Transmitter

	Memograph M CVM40
	
Recorder type	Graphic data manager, paperless Record, visualize, analyze and communicate, mathematics package
Application	Process monitoring / control
Input	Optical channels: Absorbance (UV, color, NIR, cell growth), turbidity Voltage, current, RTD, TC, pulse input, frequency input
Input types	Up to 4 optical channels for max. 2 photometric sensors, 2 universal analog channels
Outputs	1 alarm relay, 5 NO relays for limit values 0/4 to 20 mA
Plot or memory storage	Internal memory 256 MB, SD card or USB stick
Interface	Integrated WEB server, fieldbus (Profibus®, Modbus) USB, TCP/IP, OPC, Ethernet, RS232/485
Local operation	4 soft keys, 2 LEDs, navigator (jog/shuttle dial)
Display type	7" TFT display, multicolor
Ambient temperature	14 to 122°F
Power supply	100 to 230 VAC 24 V AC/DC
Approvals / certificates	CE, UL, FDA 21 CFR 11

Optical Transmitter

	Model OUM960
	
Analyzer type	UV absorbance
Sensor type	OUSAF44, OUSAF45 and OUSAF46 dual channel
Input	Dual current from sensor
Range	Up to 50 AU/OD
Output	1 alarm relay, 2 process relay contacts 2 fully isolated 4 to 20 mA outputs
Power supply	100 to 250 VAC Optional 18 to 36 VDC
Ambient temperature	32 to 131°F
Display	4 x 20 character alphanumeric
Operation	Via 6 push buttons and display
Housing	Panel mount, 3.6" x 3.6"

Flow Assembly

	OUA260
	
Application	Flow assembly for certain OUSAF sensors for the measurement of UV and NIR absorption, color and turbidity
Sensor types	OUSAF44/45/46/10/12/22 and OUSTF10
Optical path lengths	0.5 mm to 90 mm
Line sizes	¼" to 4"
Optical window materials	Pyrex, quartz, sapphire
Materials	316L SS, titanium, Hastelloy, PEEK, Kynar
O-rings	Viton, silicone, EPDM, Kalrez
Process connections	Tri-clamp®, 150 lb/300 lb ANSI RF flanges, NPT female, Swagelock BVCO, Swagelock tube, tube stub
Process temperature	32 to 266°F (insure compatible with process temperature of selected sensor)
Process pressure	Up to 1450 psi depending on material, line size and process connection

Dairy Milk and Mining Solids Sensor	
	OUSAF11 Submersible optical 
Transmitter type	Memograph M CVM40 or OUM910
Application	Dairy milk, mining solids
Sensor type	Submersible color optical
Measurement range	0 to 30% TSS
Path length	5 or 10 mm
Lamp	Long life incandescent, 5 VDC
Detector type	Solid state detector
Output	Low level current
Window material	Teflon® optical head
Maximum temperature	32 to 194°F
Process connection	¼" FNPT
Sensor material	316L SS Teflon® head

Suspended Solids and Interface Sensor	
	OUSAF12 Flow through optical 
Transmitter type	Memograph M CVM40 or OUM910
Application	Solids concentration (absorbance)
Sensor type	Flow through color optical
Measurement range	200 to 10,000 ppm
Path length	0.5 to 50 mm, up to 500 mm
Lamp	Low voltage 4 watt incandescent FM Class I, Div. 1, Grps. B, C, D
Detector type	Silicone detector
Output	Low level current
Window material	Pyrex®, Lexan®, fire polished quartz, or sapphire
Maximum temperature	194°F continuous, 266°F for two hours
Maximum pressure	1500 psig dependent on material, line size and process connection
Process connection	Tri-Clamp®, 150/300 lb flange, FNPT
Sensor material	316L SS

Optical Transmitter	
	Memograph M CVM40 
Recorder type	Graphic data manager, paperless Record, visualize, analyze and communicate, mathematics package
Application	Process monitoring / control
Input	Optical channels: Absorbance (UV, color, NIR, cell growth), turbidity Voltage, current, RTD, TC, pulse input, frequency input
Input types	Up to 4 optical channels for max. 2 photometric sensors, 2 universal analog channels
Outputs	1 alarm relay, 5 NO relays for limit values 0/4 to 20 mA
Plot or memory storage	Internal memory 256 MB, SD card or USB stick
Interface	Integrated WEB server, fieldbus (Profibus®, Modbus) USB, TCP/IP, OPC, Ethernet, RS232/485
Local operation	4 soft keys, 2 LEDs, navigator (jog/shuttle dial)
Display type	7" TFT display, multicolor
Ambient temperature	14 to 122°F
Power supply	100 to 230 VAC 24 V AC/DC
Approvals / certificates	CE, UL, FDA 21 CFR 11

Optical Transmitter	
	Model OUM910 
Analyzer type	Spectral absorbance
Sensor type	OUSAF12, OUSAF11, OUSCW11
Input	Single current from sensor
Range	Up to 5 AU/OD
Output	1 alarm relay, 2 process relay contacts 2 fully isolated 4 to 20 mA outputs
Power supply	100 to 250 VAC Optional 18 to 36 VDC
Ambient temperature	32 to 131°F
Display	4 x 20 character alphanumeric
Operation	Via 6 push buttons and display
Housing	Panel mount, 3.6" x 3.6"

Flow Assembly	
	OUA260 
Application	Flow assembly for certain OUSAF sensors for the measurement of UV and NIR absorption, color and turbidity
Sensor types	OUSAF44/45/46/10/12/22 and OUSTF10
Optical path lengths	0.5 mm to 90 mm
Line sizes	¼" to 4"
Optical window materials	Pyrex, quartz, sapphire
Materials	316L SS, titanium, Hastelloy, PEEK, Kynar
O-rings	Viton, silicone, EPDM, Kalrez
Process connections	Tri-clamp®, 150 lb/300 lb ANSI RF flanges, NPT female, Swagelock BVCO, Swagelock tube, tube stub
Process temperature	32 to 266°F (insure compatible with process temperature of selected sensor)
Process pressure	Up to 1450 psi depending on material, line size and process connection

Turbidity Sensor	
	Model OUSTF10 Flow through scattered light 
Transmitter type	Memograph M CVM40
Application	Emulsions and immiscible fluids
Sensor type	Low turbidity scattered light
Measurement wavelength	Broadband VIS/NIR or NIR only; up to 200 ppm
Path length	40 mm
Lamp	4 watt incandescent, rated for FM Class I, Div. 1, Grps. B, C, D
Output	Low level current
Window material	Pyrex®, fire polished quartz, or sapphire
Maximum temperature	194°F continuous
Maximum pressure	400 psig dependent on material, line size and process connection
Process connection	FNPT, Tri-clamp®, 150/300 lb flange
Sensor material	316 SS

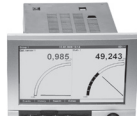
Optical Transmitter	
	Memograph M CVM40 
Recorder type	Graphic data manager, paperless Record, visualize, analyze and communicate, mathematics package
Application	Process monitoring / control
Input	Optical channels: Absorbance (UV, color, NIR, cell growth), turbidity Voltage, current, RTD, TC, pulse input, frequency input
Input types	Up to 4 optical channels for max. 2 photometric sensors, 2 universal analog channels
Outputs	1 alarm relay, 5 NO relays for limit values 0/4 to 20 mA
Plot or memory storage	Internal memory 256 MB, SD card or USB stick
Interface	Integrated WEB server, fieldbus (Profibus®, Modbus) USB, TCP/IP, OPC, Ethernet, RS232/485
Local operation	4 soft keys, 2 LEDs, navigator (jog/shuttle dial)
Display type	7" TFT display, multicolor
Ambient temperature	14 to 122°F
Power supply	100 to 230 VAC 24 V AC/DC
Approvals / certificates	CE, UL, FDA 21 CFR 11

Flow Assembly	
	OUA260 
Application	Flow assembly for certain OUSAF sensors for the measurement of UV and NIR absorption, color and turbidity
Sensor types	OUSAF44/45/46/10/12/22 and OUSTF10
Optical path lengths	0.5 mm to 90 mm
Line sizes	¼" to 4"
Optical window materials	Pyrex, quartz, sapphire
Materials	316L SS, titanium, Hastelloy, PEEK, Kynar
O-rings	Viton, silicone, EPDM, Kalrez
Process connections	Tri-clamp®, 150 lb/300 lb ANSI RF flanges, NPT female, Swagelock BVCO, Swagelock tube, tube stub
Process temperature	32 to 266°F (insure compatible with process temperature of selected sensor)
Process pressure	Up to 1450 psi depending on material, line size and process connection

Services

Commissioning services	Endress+Hauser service technicians perform the setup of the instruments according to defined Standard Operating Procedures (SOP) – this ensures constant performance quality. They are trained to application-specific regulatory requirements. Our teams use special tools designed to ensure quick and efficient commissioning of instruments and confirm the function of the device. Visit www.us.endress.com/services
FieldCare	FieldCare is Endress+Hauser's FDT based Plant Asset Management Tool that provides a range of functionality from device parametrization to engineered Condition Monitoring solutions. It can configure all intelligent field devices in your plant and supports you in managing them. Visit www.us.endress.com/fieldcare
Field Xpert	Field Xpert is a compact, flexible, ergonomic and industrial PDA adapted to your needs for high productivity. Visit www.us.endress.com/sfx100
Plant life cycle	W@M - Life Cycle Management is an open and flexible information platform with on-site tools and services supporting you along the life cycle. Availability of instrument data 24 hours a day 365 days a year. Visit www.us.endress.com/wam
Applicator	Applicator is a convenient tool for selection and sizing of the appropriate measuring instrument. Simply enter your parameters and Applicator will determine a reliable selection of suitable devices. Applicator is available as an online tool or on CD. Visit www.us.endress.com/applicator
Technical support	We will support you throughout the entire product lifecycle, be it in troubleshooting, emergency spares, calibration or straight-forward advice . Visit www.us.endress.com/support
Repair	We offer technical checks, preventative maintenance, and repair followed by functional or even metrological tests as well as calibration in our local or accredited laboratories. Visit www.us.endress.com/services
Field Service	Our dedicated team of troubleshooters are always on hand in emergencies for fast and efficient diagnosis and repair. Visit www.us.endress.com/fieldservice
Calibration services	From regular checking to validation and calibration generations, Endress+Hauser delivers cost-effective services that covers all your critical measuring points. All of our calibration laboratories and primary facilities are traceable to national and international standards. On-site calibration is available and is performed by our highly trained staff. Calibration services can include adjustment, repair or replacement of the equipment. Primary calibration facilities operate and are accredited to ISO 17025. Visit www.us.endress.com/calibration
Calibration Management	Ensure continuous product quality with Calibration Mangement (calibration cycles, schedules for performing calibration, coordination of personnel and certified calibration equipment). Visit www.us.endress.com/services
Maintenance services	Endress+Hauser offers a range of maintenance services that includes several levels of support (Preventative, Extended, Total) allowing increased control of your maintenance budget. Visit www.us.endress.com/maintenance_services
Support services	Support Services is a portfolio of services dedicated to support you remotely by phone and email, in order to keep your Endress+Hauser installed base, software, and/or automated solutions running smoothly over time. Visit www.us.endress.com/services
Process Training University (now includes End User Academy)	60 years of instrument and industry experience built it into training that helps our customers get the hands-on experience and knowledge they need. Our training packages are not merely limited to classroom and laboratory experiences, but have been broadened to include on-line training (End User Adademy) and on-site training as well. We can even help you design a blended approach. Classroom and laboratory courses are held at one of our many Process Training Unit (PTU™) locations across the country. Visit www.us.endress.com/training

Solutions

Tank and Terminal Management Solutions	Solutions for custody transfer, inventory control and business administration. Endress+Hauser solutions include: design, production, installation, servicing of instrumentation, data acquisition, and business process integration
Fluid Management Solutions	Endress+Hauser provides turnkey Fluid Management Solutions to suit your high accuracy requirements during the loading and offloading, bunkering as well as batching processes
Field Network Engineering	Reduce risk and capital expenditure with your partner in digital communication. Endress+Hauser offers a complete set of services to design, engineer, install, commission and maintain a network solution, taking responsibility for the overall performance of the solution.
Inventory Management Solutions	Comprehensive solutions that incorporate a full range of measurement devices and communication systems for data collection and transmission along with inventory management software and value added services. Providing complete inventory visibility 24 hours a day, 7 days a week, anywhere in the world via our intuitive web interface.
Plant Asset Management	Supports you in optimizing your installed base in the commissioning and operation phase. Our comprehensive portfolio supports you with instruments, solutions and services. We provide valuable asset information over the entire life cycle.

NOTES

NOTES

**USA**

Endress+Hauser, Inc.
2350 Endress Place
Greenwood, IN 46143
Tel: 317-535-7138
Sales: 888-ENDRESS
(888-363-7377)
Service: 800-642-8737
Fax: 317-535-8498
inquiry@us.endress.com
www.us.endress.com

Canada

Endress+Hauser Canada
1075 Sutton Drive
Burlington, ON L7L 5Z8
Tel: 905-681-9292
800-668-3199
Fax: 905-681-9444
info@ca.endress.com
www.ca.endress.com

Mexico

Endress+Hauser México S.A. de C.V.
Fernando Montes de Oca 21 Edificio A Piso 3
Frac. Industrial San Nicolás
54030 Tlalnepantla de Baz
Estado de México
México
Tel: +52 55 5321 2080
Fax: +52 55 5321 2099
eh.mexico@mx.endress.com
www.mx.endress.com

Other locations

www.addresses.endress.com