



Level



Pressure



Flow



Temperature



Liquid
Analysis



Registration



Systems
Components



Services



Solutions

Operating Instructions

Liquicap M FTI51, FTI52

Capacitance point level switch

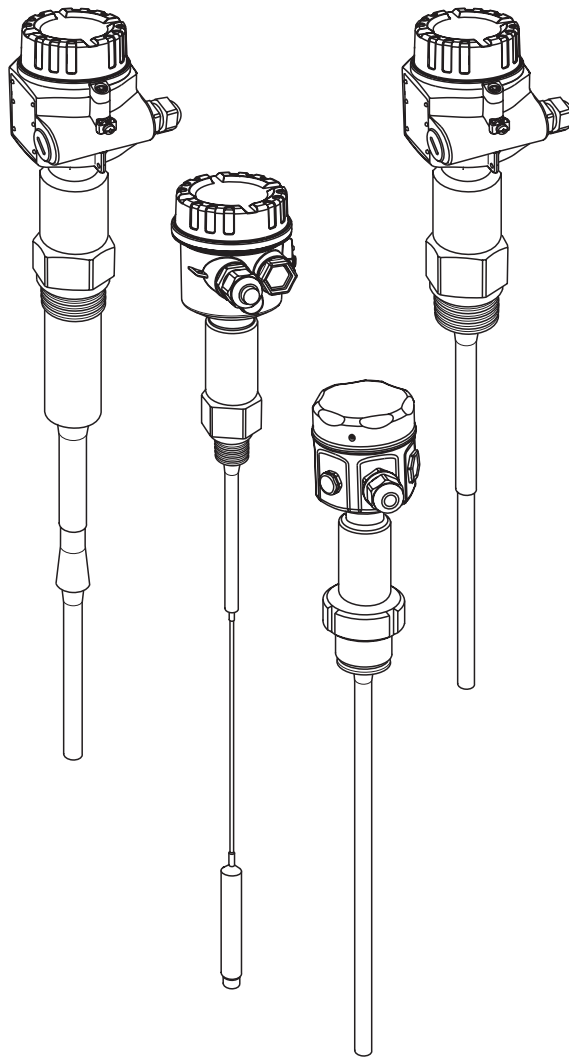

Table of contents

1	Safety instructions	3	7	Maintenance	69
1.1	Designated use	3	8	Accessories	70
1.2	Installation, commissioning and operation	3	8.1	Protective cover	70
1.3	Operational safety	3	8.2	Shortening kit for FTI52	70
1.4	Safety conventions and symbols	4	8.3	Overvoltage protection HAW56x	70
2	Identification	5	8.4	Weld-in adapter	70
2.1	Device designation	5	9	Troubleshooting	71
2.2	Scope of delivery	12	9.1	Fault diagnostics in the electronic insert	71
2.3	Certificates and approvals	12	9.2	Spare Parts	72
2.4	Trademarks	12	9.3	Return	73
3	Installation	13	9.4	Disposal	73
3.1	Quick installation guide	13	9.5	Firmware history	73
3.2	Incoming acceptance and storage	13	9.6	Contact addresses at Endress+Hauser	74
3.3	Installation instructions	14	10	Technical data	74
3.4	Measuring conditions	16	10.1	Capacitance values of the probe	74
3.5	Installation examples	16	10.2	Input	74
3.6	With separate housing	21	10.3	Output	75
3.7	Probe without active buildup compensation	23	10.4	Performance characteristics	75
3.8	Probe with active buildup compensation	25	10.5	Operating conditions: Environment	75
3.9	Installation conditions	27	10.6	Operating conditions: Process	76
3.10	Post-installation check	29	10.7	Other standards and guidelines	79
4	Wiring	30	10.8	Documentation	80
4.1	Connection recommendation	30	Index	82	
4.2	Wiring and connecting	32			
4.3	Connecting the electronic insert FEI51 (AC 2-wire)	34			
4.4	Connecting the electronic insert FEI52 (DC PNP)	35			
4.5	Connecting the electronic insert FEI53 (3-WIRE)	36			
4.6	Connecting the electronic insert FEI54 (AC/DC with relay output)	37			
4.7	Connecting the electronic insert FEI55 (8/16 mA; SIL2/SIL3)	38			
4.8	Connecting the electronic insert FEI57S (PFM)	39			
4.9	Connecting the electronic insert FEI58 (NAMUR)	40			
4.10	Post-connection check	41			
5	Operation	42			
5.1	Human interface and display elements for FEI51, FEI52, FEI54, FEI55	42			
5.2	Human interface and display elements for FEI53, FEI57S	44			
5.3	Human interface and display elements for FEI58	45			
6	Commissioning	46			
6.1	Installation and function check	46			
6.2	Commissioning the electronic inserts FEI51, FEI52, FEI54, FEI55	46			
6.3	Commissioning with electronic inserts FEI53 or FEI57S	62			
6.4	Commissioning with the electronic insert FEI58	64			

1 Safety instructions

1.1 Designated use

The Liquicap M FTI51 and FTI52 are compact point level switches for the capacitance point level detection of liquids.

1.2 Installation, commissioning and operation

The Liquicap M has been safely built with state-of-the-art technology and meets all applicable standards and EU directives. However, if it is used improperly or if it is not put to its intended use, it can be a source of application-related dangers, such as product overflow due to incorrect installation or configuration. Therefore, the installation, electrical connection, commissioning, operation and maintenance of the measuring device only may be carried out by trained specialist personnel authorized by the facility's owner/operator for this purpose. The specialist personnel must have read and understood these Operating Instructions and must follow the instructions they contain. Modifications or repairs to the device can be carried out only if it is expressly stated in the Operating Instructions that these are permitted.

1.3 Operational safety

When performing configuration, testing and maintenance work on the device, alternative supervisory measures must be taken to guarantee the operational safety and process safety.













1.3.1 Hazardous areas

If the measuring system is used in hazardous areas, the corresponding national/federal standards and regulations must be observed. The device is accompanied by separate Ex documentation, which is an integral part of this documentation. Observe the installation instructions, connection data and safety instructions provided there.

- Ensure that the specialists are adequately trained.
- Observe the metrological and technical safety requirements for the measuring points.

1.4 Safety conventions and symbols

We have defined the following safety instructions to indicate safety-related or alternative procedures. Each instruction is identified by a corresponding pictogram.

Safety instructions	
	<p>Warning! This symbol indicates an action or procedure which, if not performed correctly, can result in serious injury, a safety hazard or the destruction of the device.</p>
	<p>Caution! This symbol indicates an action or procedure which, if not performed correctly, can result in injury or destruction of the device.</p>
	<p>Note! This symbol indicates an action or procedure which, if not performed correctly, can have an indirect effect on operation or trigger an unexpected response on the part of the device.</p>
Type of protection	
	<p>Explosion-protected, prototype-tested apparatus If this symbol appears on the nameplate of the device, the device can be used in hazardous or non-hazardous areas according to its approval.</p>
	<p>Hazardous areas In the drawings in these Operating Instructions, this symbol identifies hazardous areas. Devices located in hazardous areas and lines for these devices must have corresponding explosion protection.</p>
	<p>Safe areas (non-hazardous areas) In the drawings in these Operating Instructions, this symbol identifies non-hazardous areas. Devices in the non-hazardous area also must be certified if the connecting lines lead into the hazardous area.</p>
Electrical symbols	
	<p>Direct current A terminal at which DC voltage is present or through which DC voltage flows.</p>
	<p>Alternating current A terminal at which AC voltage (sinusoidal) voltage is present or through which AC flows.</p>
	<p>Ground connection A grounded terminal which, from the viewpoint of the user, is grounded via a grounding system.</p>
	<p>Protective ground connection A terminal that has to be grounded before other connections can be made.</p>
	<p>Equipotential connection A connection that has to be connected to the grounding system of the plant. This can be a potential matching line or a star grounding system, depending on national or company codes of practice.</p>
	<p>Temperature resistance of the connecting cables Indicates that the connecting cables must be able to withstand temperatures of at least 85 °C.</p>

2 Identification

2.1 Device designation

2.1.1 Nameplate

Refer to the nameplate of the device for the following data:

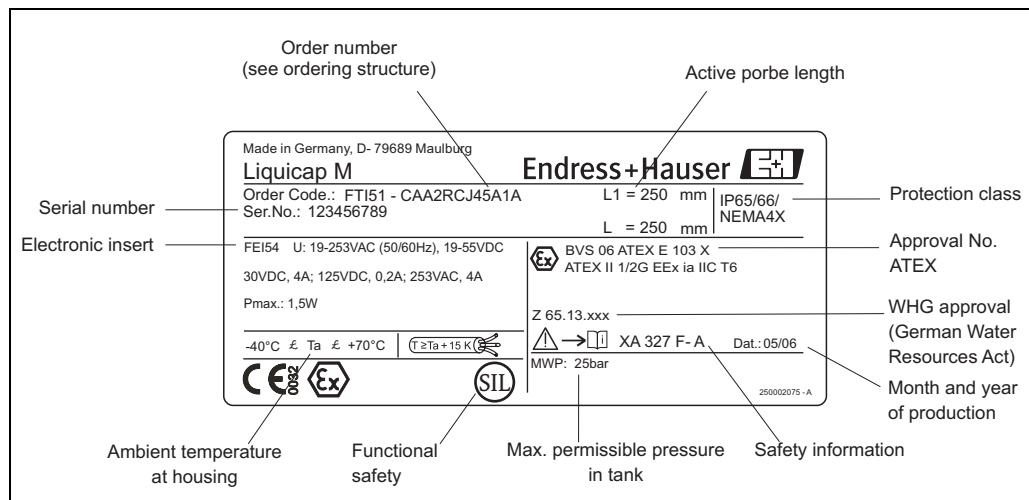

Information on the Liquicap M nameplate (example)

2.1.2 Product structure



Note!

The product structure is used to identify the alphanumeric order number (see nameplate: Order Code).

Liquicap M FTI51 (device identification)

10	Approval:
A	Non-hazardous areas
B	Non-hazardous areas, WHG (German Water Resources Act)
C	ATEX II 1/2 GD EEx ia IIC T6
D	ATEX II 1/2 GD EEx ia IIC T6, WHG (German Water Resources Act)
G	ATEX II 1/2 GD EEx de (ia) IIC T6, WHG (German Water Resources Act)
	XA, observe safety instructions (electrostatic charge)!
H	ATEX II 1/2 GD EEx ia IIC T6, WHG (German Water Resources Act)
	XA, observe safety instructions (electrostatic charge)!
J	ATEX II 1/2 GD EEx ia IIC T6, WHG (German Water Resources Act)
	XA, observe safety instructions (electrostatic charge)!
K	ATEX II 1/2 G EEx ia IIC T6, WHG (German Water Resources Act)
	XA, observe safety instructions (electrostatic charge)!
L	ATEX II 1/2 G EEx de (ia) IIC T6, WHG (German Water Resources Act)
	XA, observe safety instructions (electrostatic charge)!
M	ATEX II 3GD EEx nA/nL/nC II T6, WHG (German Water Resources Act)
	XA, observe safety instructions (electrostatic charge)!
N	CSA General Purpose, C US CSA
P	CSA/FM IS Cl. I, II, III Div. 1+2 Gr. A-G
R	CSA/FM XP Cl. I, II, III Div. 1+2 Gr. A-G
S	TIIS Ex ia IIC T3
T	TIIS Ex d IIC T3
Y	Special version, to be specified
1	NEPSI Ex ia IIC T6
2	NEPSI Ex d(ia) IIC T6
4	NEPSI Ex nA/nC IIC T6
5	IECEx Ga/Gb Ex ia IIC T6; Ex iaD 20/Ex tD A21

10	Approval:			
		6	IECEx Ga/Gb Ex ia IIC T6	
20	Inactive length (L3):			
			L3: 100 to 2000 mm/4 to 80 inch for 316L L3: 150 to 1000 mm/6 to 40 inch for PTFE fully insulated Protection against condensate + bypassing container nozzles	
		A	Not selected	
		B	Not selected + 125mm/5inch Active buildup compensation	316L
		C	Not selected + 125mm/5inch Fully insulated active buildup compensation	PFA, 316L
			Price per 100 mm	
		1	... mm	316L
		2	... mm	316L, PTFE fully insulated
			Price is irrespective of the length	
		3	... mm (<= 500 mm) + 125 mm active buildup compensation	316L
		4	... mm (> 500 mm) + 125 mm active buildup compensation	316L
			Price per one inch	
		5	... inch	316L
		6	... inch	316L, PTFE fully insulated
			Price is irrespective of the length	
		7	... inch (<= 20 inch) + 5 inch active buildup compensation	316L
		8	... inch (> 20 inch) + 5 inch active buildup compensation	316L
		9	Special version, to be specified	
30	Active probe length (L1); insulation:			
			Price per 100 mm/1 inch L1: 100 to 4000 mm/4 to 160 inch for Ø10 mm, Ø16 mm L1: 150 to 3000 mm/6 to 120 inch for Ø22 mm (fully insulated)	
		A	mm L1, 10 mm,	316L; PTFE
		B	mm L1, 16 mm,	316L; PTFE
		C	mm L1, 22 mm,	316L; PTFE
		D	mm L1, 16 mm,	316L; PFA
		E	mm L1, 10 mm,	316L; PTFE + ground tube
		F	mm L1, 16 mm,	316L; PTFE + ground tube
		G	mm L1, 16 mm,	316L; PFA + ground tube
		H	inch L1, 0.4 inch,	316L; PTFE
		K	inch L1, 0.6 inch,	316L; PTFE
		M	inch L1, 0.9 inch,	316L; PTFE
		N	inch L1, 0.6 inch,	316L; PFA
		P	inch L1, 0.4 inch,	316L; PTFE + ground tube
		R	inch L1, 0.6 inch,	316L; PTFE + ground tube
		S	inch L1, 0.6 inch,	316L; PFA + ground tube
		T	inch L1, 0.55 inch,	316L; PFA
		Y	Special version, to be specified	
		l	mm L1, 14 mm,	316L; PFA
40	Insulation (L2)			
		1	Fully insulated	
		2	... mm, partially insulated	
		3	... inch, partially insulated	
		9	Special version, to be specified	
50	Process connection:			Ø Inactive length (mm)
			Threaded connection	
		GCJ	G ½,	316L, 25 bar Thread ISO228 22
		GDJ	G ¾,	316L, 25 bar Thread ISO228 22
		GEJ	G 1,	316L, 25 bar Thread ISO228 22
		GGJ	G 1½,	316L, 100 bar Thread ISO228 43
		RCJ	NPT ½,	316L, 25 bar Thread ANSI 22
		RDJ	NPT ¾,	316L, 25 bar Thread ANSI 22
		REJ	NPT 1,	316L, 25 bar Thread ANSI 22
		RGJ	NPT 1½,	316L, 100 bar Thread ANSI 43
			Hygiene connection	
		GQJ	G ¾	316L, 25 bar, EHEDG Thread ISO228 -

50	Process connection:				Ø Inactive length (mm)
			Accessories installation, weld-in adapter		
	GWJ	G 1	316L, 25 bar, EHEDG	Thread ISO228	–
			Accessories installation, weld-in adapter		
	MRJ	DN50 PN40,	316L	DIN11851	22/43**
	UPJ	Adapter 44 mm	316L, 16 bar		–
		Tri-Clamp connection			
	TCJ	DN25 (1"), EHEDG	316L,	Tri-Clamp ISO2852	22
	TJJ	DN38 (1½"), EHEDG	316L,	Tri-Clamp ISO2852	22
	TJK	DN38 (1½"), EHEDG	PTFE >316L, 3A	Tri-Clamp ISO2852	22
	TDJ	DN40-51 (2"),	316L,	Tri-Clamp ISO2852	43
	TDK	DN40-51 (2"), EHEDG	PTFE >316L, 3A,	Tri-Clamp ISO2852	–
	TNJ	DN38 (1½"),	316L, 3A, EHEDG	Tri-Clamp ISO2852	–
		Tri-Clamp removable			
		EN flanges			
	B0J	DN25 PN25/40 A,	316L	Flange EN1092-1 (DIN2527 B)	22
	B1J	DN32 PN25/40 A,	316L	Flange EN1092-1 (DIN2527 B)	22
	B2J	DN40 PN25/40 A,	316L	Flange EN1092-1 (DIN2527 B)	22
	B3J	DN50 PN25/40 A,	316L	Flange EN1092-1 (DIN2527 B)	22/43**
	CRJ	DN50 PN25/40 B1,	316L	Flange EN1092-1 (DIN2527 C)	43
	DRJ	DN50 PN40 C,	316L	Flange EN1092-1 (DIN2512 F)	43
	ERJ	DN50 PN40 D,	316L	Flange EN1092-1 (DIN2512 N)	43
	BSJ	DN80 PN10/16 A,	316L	Flange EN1092-1 (DIN2527 B)	43
	CGJ	DN80 PN10/16 B1,	316L	Flange EN1092-1 (DIN2527 C)	43
	DGJ	DN80 PN16 C,	316L	Flange EN1092-1 (DIN2512 F)	43
	EGJ	DN80 PN16 D,	316L	Flange EN1092-1 (DIN2512 N)	43
	BTJ	DN100 PN10/16 A,	316L	Flange EN1092-1 (DIN2527 B)	43
	CHJ	DN100 PN10/16 B1,	316L	Flange EN1092-1 (DIN2527 C)	43
		PTFE clad			
	B0K	DN25 PN25/40,	PTFE >316L	Flange EN1092-1 (DIN2527)	–
	B1K	DN32 PN25/40,	PTFE >316L	Flange EN1092-1 (DIN2527)	–
	B2K	DN40 PN25/40,	PTFE >316L	Flange EN1092-1 (DIN2527)	–
	B3K	DN50 PN25/40,	PTFE >316L	Flange EN1092-1 (DIN2527)	–
	BSK	DN80 PN10/16,	PTFE >316L	Flange EN1092-1 (DIN2527)	–
	BTK	DN100 PN10/16,	PTFE >316L	Flange EN1092-1 (DIN2527)	–
		ANSI flanges			
	ACJ	1" 150 lbs RF,	316/316L	Flange ANSI B16.5	22
	ANJ	1" 300 lbs RF,	316/316L	Flange ANSI B16.5	22
	AEJ	1½" 150 lbs RF,	316/316L	Flange ANSI B16.5	22
	AQJ	1½" 300 lbs RF,	316/316L	Flange ANSI B16.5	22
	AFJ	2" 150 lbs RF,	316/316L	Flange ANSI B16.5	22/43**
	ARJ	2" 300 lbs RF,	316/316L	Flange ANSI B16.5	22/43**
	AGJ	3" 150 lbs RF,	316/316L	Flange ANSI B16.5	43
	ASJ	3" 300 lbs RF,	316/316L	Flange ANSI B16.5	43
	AHJ	4" 150 lbs RF,	316/316L	Flange ANSI B16.5	43
	ATJ	4" 300 lbs RF,	316/316L	Flange ANSI B16.5	43
	AJJ	6" 150 lbs RF,	316/316L	Flange ANSI B16.5	43
	AUJ	6" 300 lbs RF,	316/316L	Flange ANSI B16.5	43
		PTFE clad			
	ACK	1" 150 lbs,	PTFE >316/316L	Flange ANSI B16.5	–
	ANK	1" 300 lbs,	PTFE >316/316L	Flange ANSI B16.5	–
	AEK	1½" 150 lbs,	PTFE >316/316L	Flange ANSI B16.5	–
	AQK	1½" 300 lbs,	PTFE >316/316L	Flange ANSI B16.5	–
	AFK	2" 150 lbs,	PTFE >316/316L	Flange ANSI B16.5	–

50		Process connection:				∅ Inactive length (mm)
	ARK	2" 300 lbs,	PTFE >316/316L	Flange ANSI B16.5	-	
	AGK	3" 150 lbs,	PTFE >316/316L	Flange ANSI B16.5	-	
	AHK	4" 150 lbs,	PTFE >316/316L	Flange ANSI B16.5	-	
	JIS flanges					
	KCJ	10K 25 RF,	316L	Flange JIS B2220	22	
	KEJ	10K 40 RF,	316L	Flange JIS B2220	22	
	KFJ	10K 50 RF,	316L	Flange JIS B2220	22/43**	
	KGJ	10K 80 RF,	316L	Flange JIS B2220	22/43**	
	KHJ	10K 100 RF,	316L	Flange JIS B2220	22/43**	
	KRJ	20K 50 RF,	316L	Flange JIS B2220	43	
		PTFE clad				
	KCK	10K 25 RF,	PTFE >316L	Flange JIS B2220	-	
	KEK	10K 40 RF,	PTFE >316L	Flange JIS B2220	-	
	KFK	10K 50 RF,	PTFE >316L	Flange JIS B2220	-	
	KGK	10K 80 RF,	PTFE >316L	Flange JIS B2220	-	
	KHK	10K 100 RF,	PTFE >316L	Flange JIS B2220	-	
	YY9	Special version, to be specified				
60		Electronics				
	W	Prepared for FEI5x				
	Y	Special version, to be specified				
	1	FEI51; 2-wire	19-253 V AC			
	2	FEI52; 3-wire PNP,	10 to 55 V DC			
	3	FEI53; 3-wire,	3 to 12 V signal			
	4	FEI54; relay DPDT,	19 to 253 V AC, 19 to 55 V DC			
	5	FEI55; 8/16mA,	11 to 36 V DC			
	7	FEI57S;2-wire PFM				
	8	FEI58; NAMUR+test key (H-L signal)				
70		Housing:				
	1	F15 316L	IP66, NEMA4X			
	2	F16 polyester	IP66, NEMA4X			
	3	F17 aluminum	IP66, NEMA4X			
	4	F13 Alu + gas-tight probe seal	IP66, NEMA4X			
	5	T13 Alu + gas-tight probe seal + separate connection compartment	IP66, NEMA4X			
	6	F27 316L + gas-tight probe seal	IP68, NEMA6P			
	9	Special version, to be specified				
80		Cable entry:				
	A	Threaded joint M20 (EEx d > M20 thread)				
	B	Thread G ½				
	C	Thread NPT ½				
	D	Thread NPT ¾				
	E	M12 connector				
	Y	Special version, to be specified				
90		Probe design:				
	1	Compact				
	2	2000 mm L4 cable	> separate housing			
	3mm L4 cable	> separate housing			
	4	80 inch L4 cable	> separate housing			
	5inch L4 cable	> separate housing			
	9	Special version, to be specified				
100		Additional equipment:				
	A	Basic version				
	B	Cleaned for applications free from paint-wetting impairment substances*				
	C	Finished metal probe rod surface**				
	D	EN10204-3.1 (316L wetted),	Inspection certificate			
	E	EN10204-3.1 (316L wetted), NACE MR0175	Inspection certificate			
	F	SIL Declaration of Conformity				
	S	GL marine approval				
	Y	Special version, to be specified				
FTI51		Product designation				
* With this option, the complete device is cleaned for applications free from paint-wetting impairment substances.						
** With this option, the surface of the probe rod (316L) is passivated and acts as additional corrosion protection.						

Liquicap M FTI52

10	Approval:			
A	Non-hazardous areas			
B	Non-hazardous areas,		WHG (German Water Resources Act)	
G	ATEX II 1/2 GD	EEx de (ia) IIC T6,	WHG (German Water Resources Act)	
	XA, observe safety instructions (electrostatic charge)!			
H	ATEX II 1/2 GD	EEx ia IIC T6,		
	XA, observe safety instructions (electrostatic charge)!			
J	ATEX II 1/2 GD	EEx ia IIC T6,	WHG (German Water Resources Act)	
	XA, observe safety instructions (electrostatic charge)!			
K	ATEX II 1/2 G	EEx ia IIC T6,	WHG (German Water Resources Act)	
	XA, observe safety instructions (electrostatic charge)!			
L	ATEX II 1/2 G	EEx de (ia) IIC T6,	WHG (German Water Resources Act)	
	XA, observe safety instructions (electrostatic charge)!			
M	ATEX II 3GD	EEx nA/nL/nC II T6,	WHG	
	XA, observe safety instructions (electrostatic charge)!			
N	CSA General Purpose, C US CSA			
P	CSA/FM IS	Cl. I, II, III	Div. 1+2 Gr. A-G	
R	CSA/FM XP	Cl. I, II, III	Div. 1+2 Gr. A-G	
S	TIIS Ex ia IIC T3			
T	TIIS Ex d IIC T3			
Y	Special version, to be specified			
1	NEPSI Ex ia IIC T6			
2	NEPSI Ex d(ia) IIC T6			
4	NEPSI Ex nA/nC IIC T6			
5	IECEX Ga/Gb Ex ia IIC T6; Ex iaD 20/Ex tD A21			
6	IECEX Ga/Gb Ex ia IIC T6			
20	Inactive length L3:			
	Price per 100 mm/1 inch			
	L3: 100 to 2000 mm/4 to 80 inch for 316L			
	L3: 150 to 1000 mm/6 to 40 inch for PFA fully insulated			
	Protection against condensate + bypassing container nozzles			
A	Not selected			
1	... mm,	316L		
2	... mm,	316L + PFA fully insulated		
5	... inch,	316L		
6	... inch,	316L + PFA fully insulated		
9	Special version, to be specified			
30	Active probe length L1; insulation:			
	Price per 1000 mm/10 inch			
	L1: 420 to 10000 mm/17 to 400 inch; fully insulated			
A	... mm,	316; FEP		
B	... mm,	316; PFA		
C	... inch,	316; FEP		
D	... inch,	316; PFA		
Y	Special version, to be specified			
40	Insulation L2			
1	Fully insulated			
9	Special version, to be specified			
50	Process connection:			∅ Inactive length (mm)
	Threaded connection			
GDJ	G ¾,	316L, 25 bar	Thread ISO228	22
GEJ	G 1,	316L, 25 bar	Thread ISO228	22
GGJ	G 1½,	316L, 100 bar	Thread ISO228	43
RDJ	NPT ¾,	316L, 25 bar	Thread ANSI	22
REJ	NPT 1,	316L, 25 bar	Thread ANSI	22
RGJ	NPT 1½,	316L, 100 bar	Thread ANSI	43
	Hygiene connection			
GWJ	G 1	316L, 25 bar, EHEDG	Thread ISO228	–
	Accessories installation, weld-in adapter			
MRJ	DN50 PN40,	316L	DIN11851	43
UPJ	Adapter 44 mm	316L, 16 bar, EHEDG		–
	Tri-Clamp connection			
TCJ	DN25 (1"), EHEDG	316L,	Tri-Clamp ISO2852	22
TJJ	DN38 (1½"), EHEDG	316L,	Tri-Clamp ISO2852	22
TJK	DN38 (1½"), EHEDG	PTFE >316L, 3A	Tri-Clamp ISO2852	22

50	Process connection:			∅ Inactive length (mm)	
	TDJ	DN40-51 (2"),	316L,	Tri-Clamp ISO2852	43
	TDK	DN40-51 (2"), EHEDG	PTFE >316L, 3A,	Tri-Clamp ISO2852	-
	EN flanges				
	B0J	DN25 PN25/40 A,	316L	Flange EN1092-1 (DIN2527 B)	22
	B1J	DN32 PN25/40 A,	316L	Flange EN1092-1 (DIN2527 B)	22
	B2J	DN40 PN25/40 A,	316L	Flange EN1092-1 (DIN2527 B)	22
	B3J	DN50 PN25/40 A,	316L	Flange EN1092-1 (DIN2527 B)	43
	CRJ	DN50 PN25/40 B1,	316L	Flange EN1092-1 (DIN2527 C)	43
	DRJ	DN50 PN40 C,	316L	Flange EN1092-1 (DIN2512 F)	43
	ERJ	DN50 PN40 D,	316L	Flange EN1092-1 (DIN2512 N)	43
	BSJ	DN80 PN10/16 A,	316L	Flange EN1092-1 (DIN2527 B)	43
	CGJ	DN80 PN10/16 B1,	316L	Flange EN1092-1 (DIN2527 C)	43
	DGJ	DN80 PN16 C,	316L	Flange EN1092-1 (DIN2512 F)	43
	EGJ	DN80 PN16 D,	316L	Flange EN1092-1 (DIN2512 N)	43
	BTJ	DN100 PN10/16 A,	316L	Flange EN1092-1 (DIN2527 B)	43
	CHJ	DN100 PN10/16 B1,	316L	Flange EN1092-1 (DIN2527 C)	43
		PTFE clad			
	B0K	DN25 PN25/40,	PTFE >316L	Flange EN1092-1 (DIN2527)	-
	B1K	DN32 PN25/40,	PTFE >316L	Flange EN1092-1 (DIN2527)	-
	B2K	DN40 PN25/40,	PTFE >316L	Flange EN1092-1 (DIN2527)	-
	B3K	DN50 PN25/40,	PTFE >316L	Flange EN1092-1 (DIN2527)	-
	BSK	DN80 PN10/16,	PTFE >316L	Flange EN1092-1 (DIN2527)	-
	BTK	DN100 PN10/16,	PTFE >316L	Flange EN1092-1 (DIN2527)	-
	ANSI flanges				
	ACJ	1" 150 lbs RF,	316/316L	Flange ANSI B16.5	22
	ANJ	1" 300 lbs RF,	316/316L	Flange ANSI B16.5	22
	AEJ	1½" 150 lbs RF,	316/316L	Flange ANSI B16.5	22
	AQJ	1½" 300 lbs RF,	316/316L	Flange ANSI B16.5	43
	AFJ	2" 150 lbs RF,	316/316L	Flange ANSI B16.5	43
	ARJ	2" 300 lbs RF,	316/316L	Flange ANSI B16.5	43
	AGJ	3" 150 lbs RF,	316/316L	Flange ANSI B16.5	43
	ASJ	3" 300 lbs RF,	316/316L	Flange ANSI B16.5	43
	AHJ	4" 150 lbs RF,	316/316L	Flange ANSI B16.5	43
	ATJ	4" 300 lbs RF,	316/316L	Flange ANSI B16.5	43
	AJJ	6" 150 lbs RF,	316/316L	Flange ANSI B16.5	43
	AUJ	6" 300 lbs RF,	316/316L	Flange ANSI B16.5	43
		PTFE clad			
	ACK	1" 150 lbs,	PTFE >316/316L	Flange ANSI B16.5	-
	ANK	1" 300 lbs,	PTFE >316/316L	Flange ANSI B16.5	-
	AEK	1½" 150 lbs,	PTFE >316/316L	Flange ANSI B16.5	-
	AQK	1½" 300 lbs,	PTFE >316/316L	Flange ANSI B16.5	-
	AFK	2" 150 lbs,	PTFE >316/316L	Flange ANSI B16.5	-
	ARK	2" 300 lbs,	PTFE >316/316L	Flange ANSI B16.5	-
	AGK	3" 150 lbs,	PTFE >316/316L	Flange ANSI B16.5	-
	AHK	4" 150 lbs,	PTFE >316/316L	Flange ANSI B16.5	-
	JIS flanges				
	KCJ	10K 25 RF,	316L	Flange JIS B2220	22
	KEJ	10K 40 RF,	316L	Flange JIS B2220	22
	KFJ	10K 50 RF,	316L	Flange JIS B2220	43
	KGJ	10K 80 RF,	316L	Flange JIS B2220	43
	KHJ	10K 100 RF,	316L	Flange JIS B2220	43
	KRJ	20K 50 RF,	316L	Flange JIS B2220	43
		PTFE clad			

2.2 Scope of delivery

The scope of delivery consists of:

- The mounted device
- Optional accessories (see →  70)

Provided documentation:

- Operating Instructions
- Approval documentation; if not listed in the Operating Instructions.

2.3 Certificates and approvals

CE mark, Declaration of conformity

The device is designed to meet state-of-the-art operating safety requirements, has been tested, and has left the factory in a condition in which it is safe to operate. The device meets the relevant standards and directives listed in the EC Declaration of Conformity and thus fulfills the legal requirements of the EC Directives. Endress+Hauser confirms that the device has been successfully tested by applying the CE mark.

2.4 Trademarks

KALREZ[®], VITON[®], TEFLON[®]

Registered trademarks of E.I. Du Pont de Nemours & Co., Wilmington, USA

Tri-Clamp[®]

Registered trademark of Ladish & Co., Inc., Kenosha, USA

3 Installation

3.1 Quick installation guide

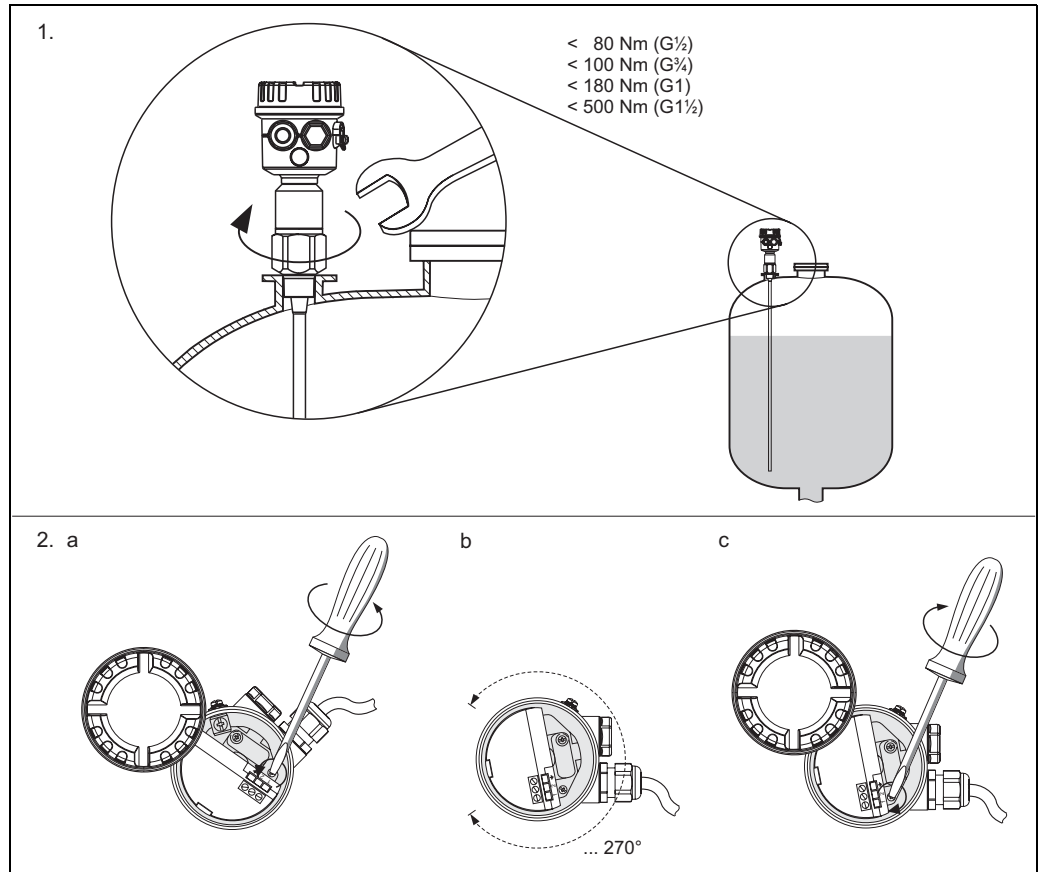

1.) Screw in the device

2. a) Release the securing screw in the housing until the housing rotates easily.

2. b) Align the housing as required.

2. c) Tighten the securing screw (< 1 Nm) until the housing can no longer be turned.

3.2 Incoming acceptance and storage

3.2.1 Incoming acceptance

Check the packaging and the contents for damage.

Check the shipment, make sure nothing is missing and that the scope of supply matches your order.

3.2.2 Storage

Pack the device so that it is protected against impact for storage and transportation. The original packaging provides optimum protection.

The permitted storage temperature is -50°C to $+85^{\circ}\text{C}$.

3.3 Installation instructions

3.3.1 Installation

Liquicap M FTI51 (rod probe) can be installed from above, from below and from the side.
Liquicap M FTI52 (rope probe) can be installed vertically from above.



Note!

- The probe may not come into contact with the container wall!
- Recommended distance from the container floor: ≥ 10 mm.
- Do not install probes in the area of the filling curtain!
- Make sure the probe is at a sufficient distance from the agitator.
- If there are strong lateral loads, use rod probes with a ground tube.

For electrically conductive tanks e.g. steel tanks

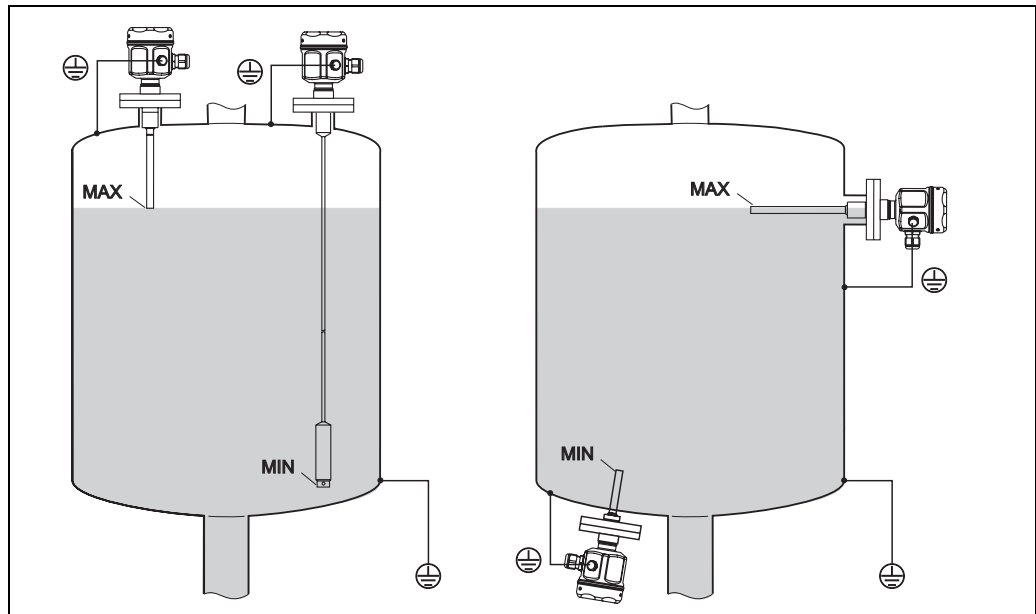

L00-FTI5xxxx-11-06-xx-xx-001

For nonconductive tanks e.g. plastic tanks

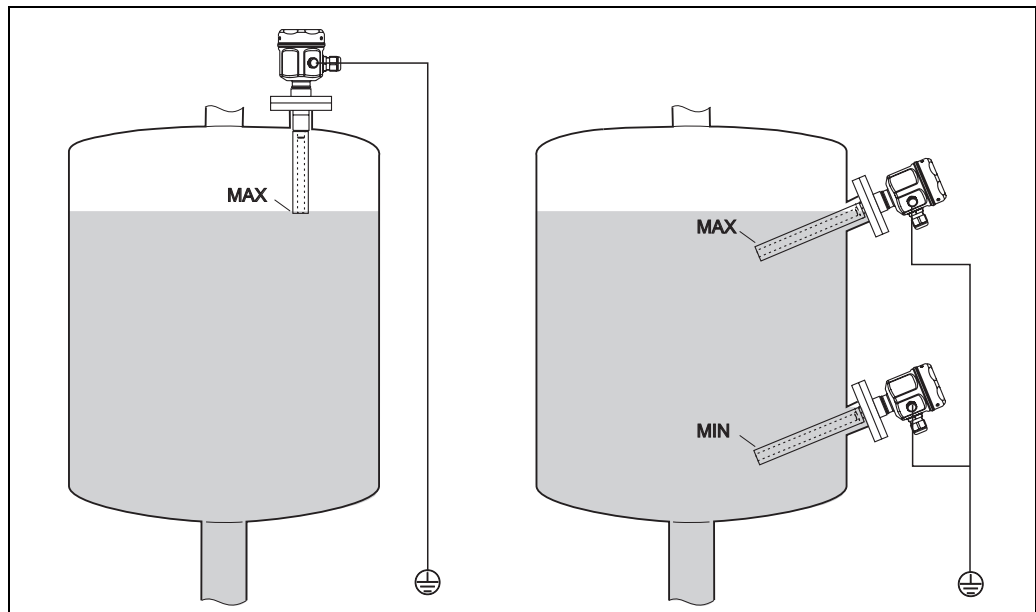

L00-FTI5xxxx-11-06-xx-xx-002

Probes with ground tube and grounding

3.3.2 Support for marine approval (GL)

Fully insulated rod probes can be supported conductively or non-conductively.
Partially insulated rod probes may only be supported with insulation at the uninsulated probe end.



Note!

Rod probes with a diameter of 10 mm and 16 mm have to be supported with a length ≥ 1 m (see drawing).

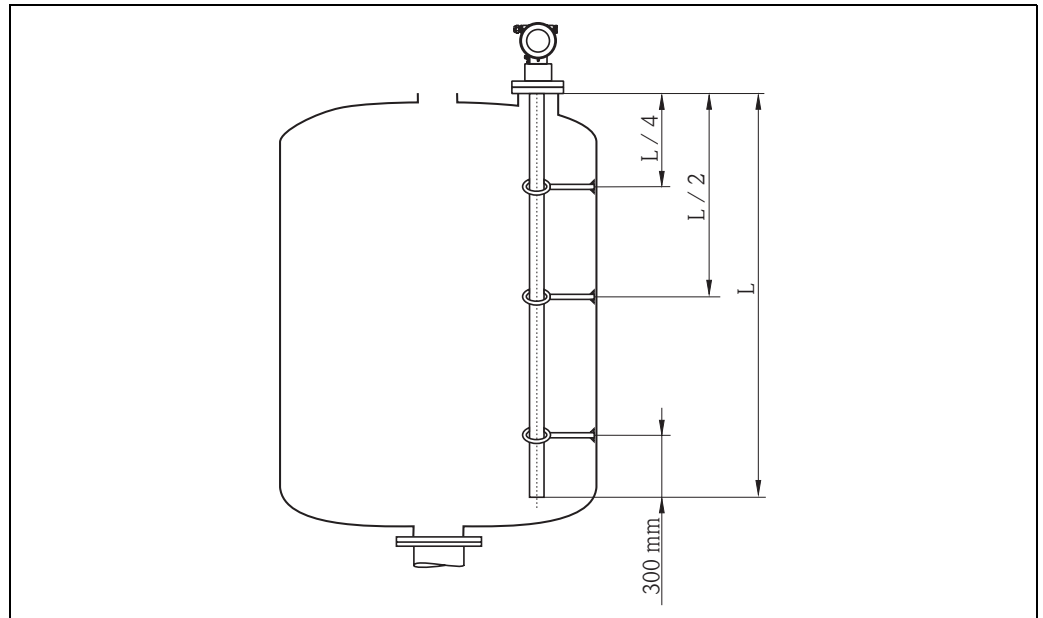

L00-FMI5xxxx-06-05-xx-xx-077

Example for calculating distances:

Probe length $L = 2000$ mm.

$L/4 = 500$ mm

$L/2 = 1000$ mm

Measured from the end of the probe rod = 300 mm.

3.4 Measuring conditions

Notes!

- When installing in a nozzle, use inactive length (L3).
- Probes with active buildup compensation must be used for high-viscosity liquids that tend to form buildup.
- Fully insulated rod and rope probes have to be used for pump control (ΔS operation). The switch-on and switch-off points are determined by the empty and full calibration.
 - The maximum length depends on the probe used.
 - A 16 mm rod generates a capacitance of 380 pF/m in a conductive liquid.
 - With a maximum span of 1600 pF, this gives $1600\text{pF}/380\text{pF per m} = 4\text{ m}$ total length.
- In the case of nonconductive media: use a ground tube

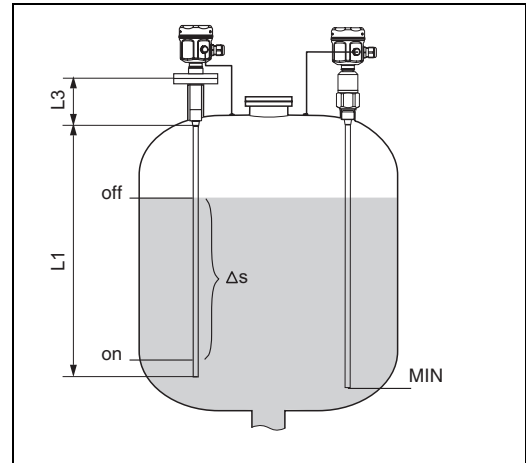

3.5 Installation examples

3.5.1 Rod probes

Conductive tanks (metal tanks)

If the process connection of the probe is insulated from the metal tank (e.g. using seal material), the ground connection on the probe housing must be connected to the tank using a short line.



Note!

- A fully insulated rod probe may be neither shortened nor extended.
- If the insulation of the probe rod is damaged, this will falsify the measurement result.
- These application examples show vertical installation for MAX point level detection.

FTI51: rod probe

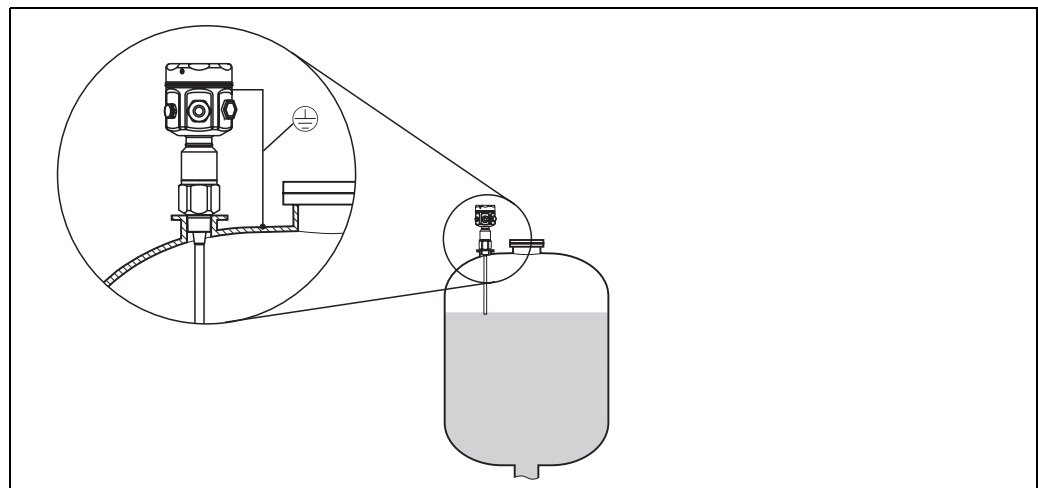

FTI51: rod probe with ground tube

Nonconductive tanks (plastic tanks)

For installation in a plastic tank, use a probe with ground tube.

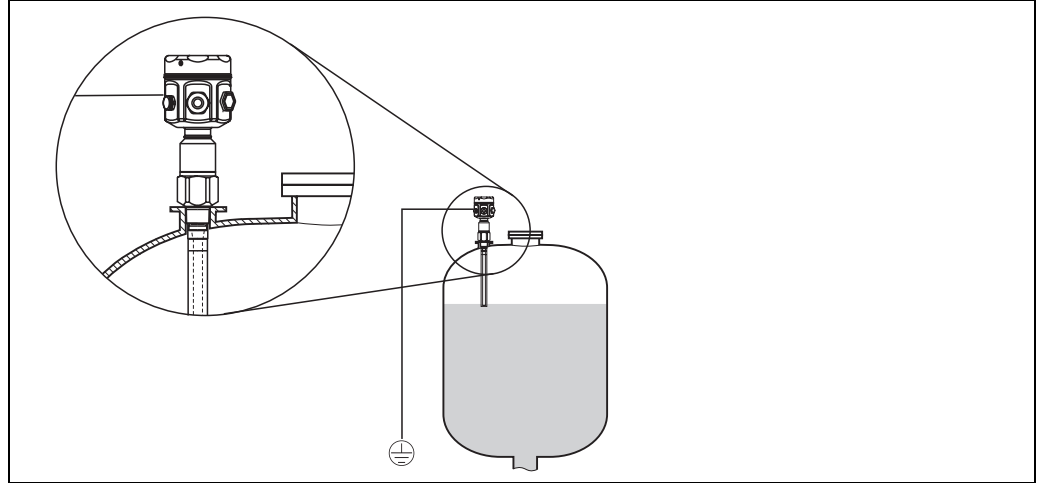

L00-FTI5xxxx-11-00-xx-xx-005

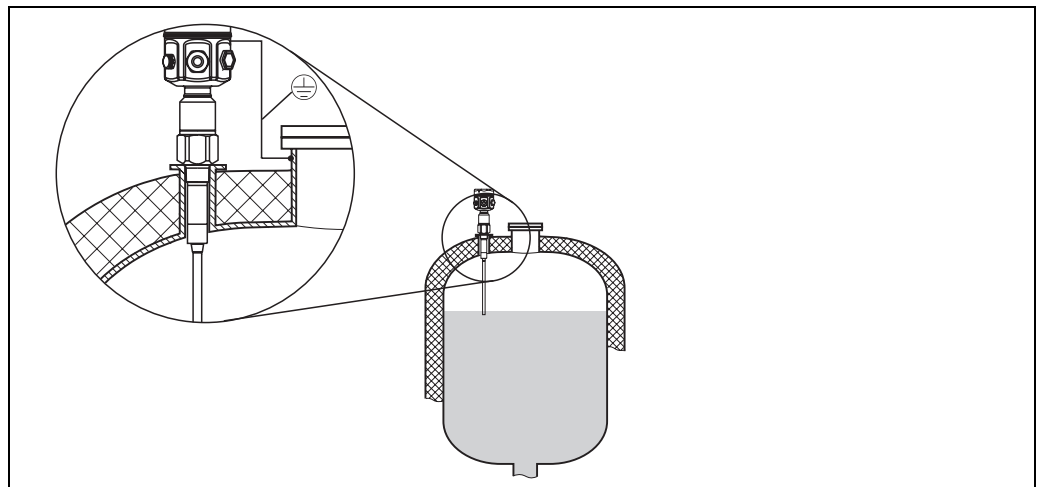
FTI51: rod probe with inactive length (e.g. for insulated tanks)

L00-FTI5xxxx-11-00-xx-xx-006

FTI51: rod probe with ground tube and inactive length (for mounting nozzles)

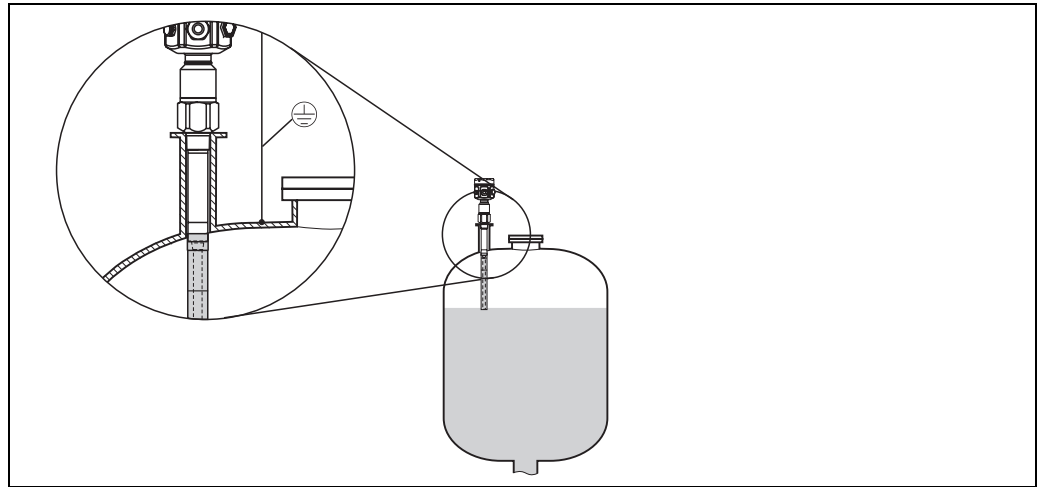

L00-FM15xxxx-11-06-xx-xx-007

FTI51: fully insulated probe with clad flange for aggressive media

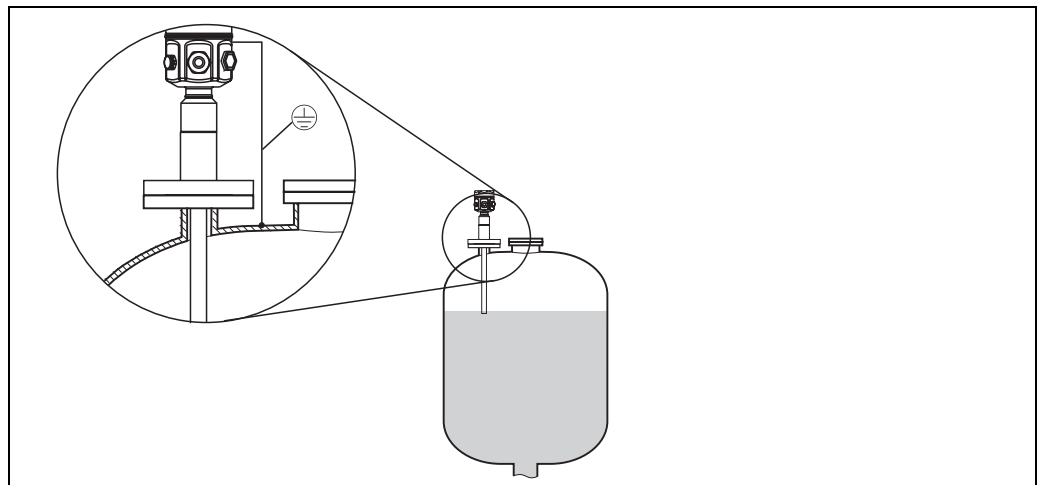

L00-FM15xxxx-11-06-xx-xx-011

3.5.2 Rope probes



Note!

These application examples show vertical installation of rope probes for MIN point level detection.

FTI52: rope probe

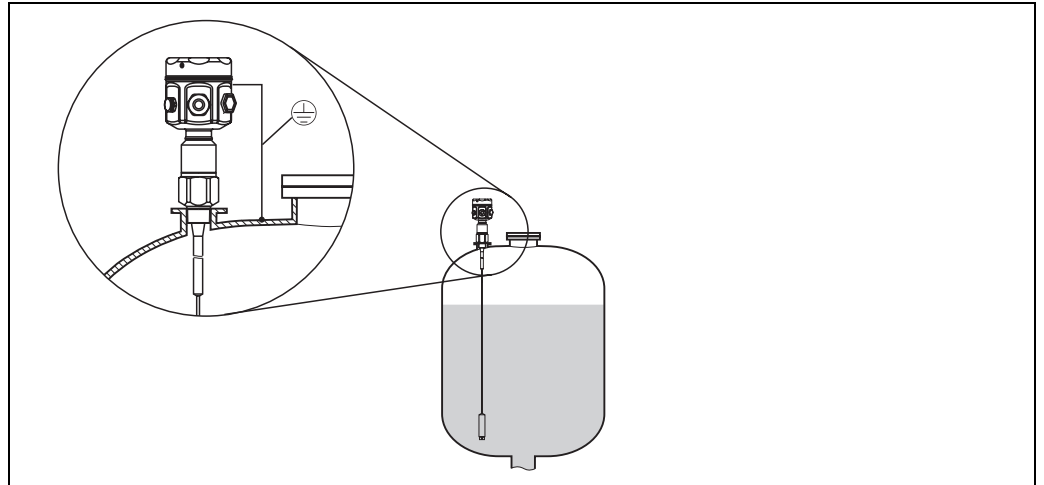

L00-FMI5xxxx-11-06-xx-xx-008

FTI52: rope probe with inactive length (e.g. for insulated tanks)

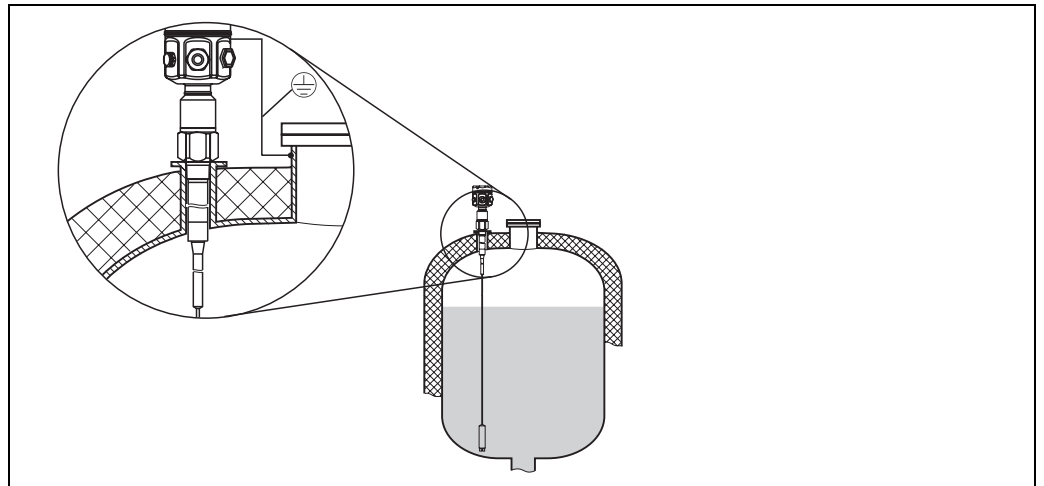

L00-FMI5xxxx-11-06-xx-xx-009

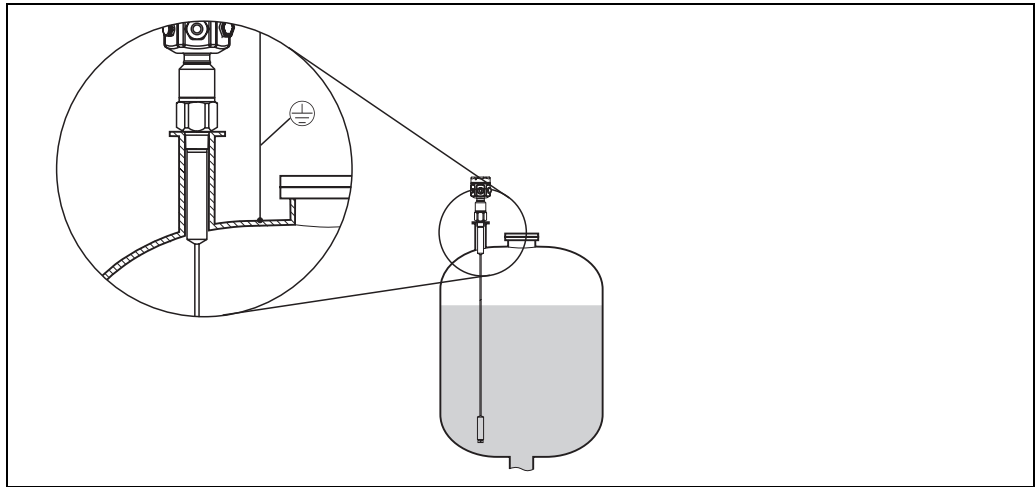
FTI52: rope probe with fully insulated inactive length (for mounting nozzles)

L00-FM15xxxx-11-06-xx-xx-010

3.5.3 Shortening the rope

Note!

Refer to the operating manual for the rope shortening kit KA061F/00/...

3.5.4 Tensioning weight with bracing

The end of the probe needs to be secured if the probe would otherwise touch the silo wall or another part in the tank. An anchor hole is provided in the probe weight for this purpose.

The bracing can be attached to the tank wall so that it is either conductive or insulating.

To prevent the danger of a high tensile load, the rope should be loose or braced with a spring. The maximum tensile load must not exceed 200 N.

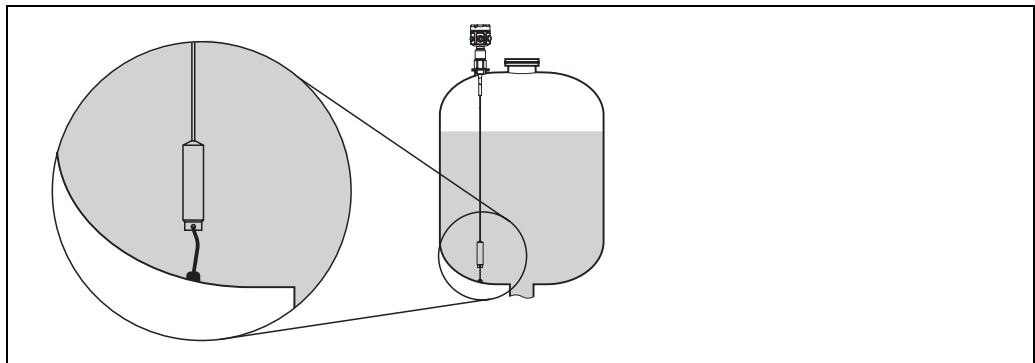

L00-FM15xxxx-11-06-xx-xx-012

3.6 With separate housing

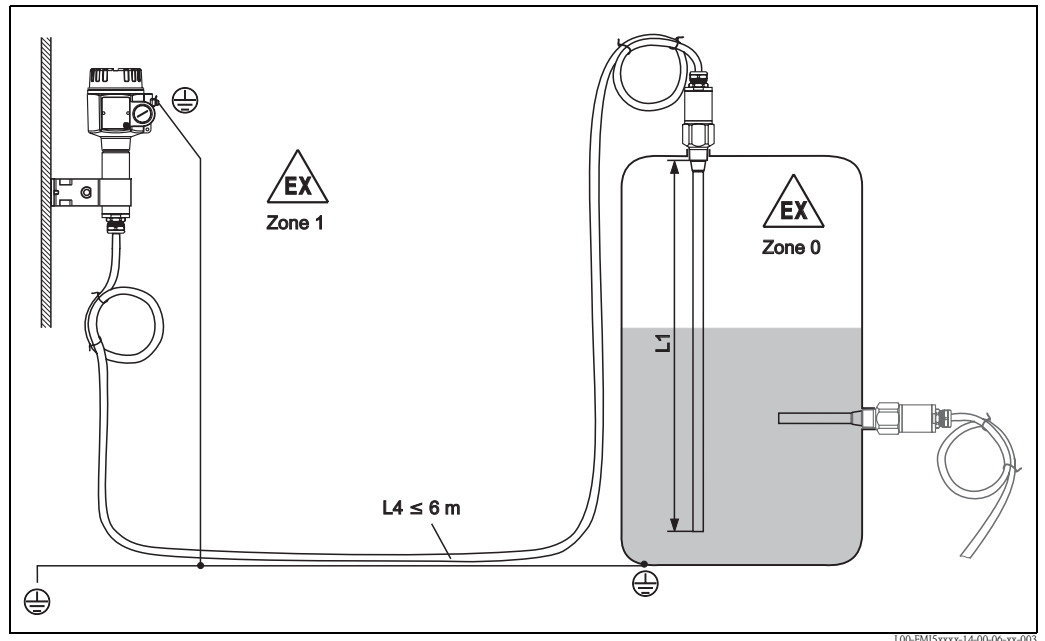

Rod length $L1$ max. 4 m

Rope length $L1$ max. 9.7 m (the maximum total length is 10 m.)



Note!

- The maximum connection length between the probe and the separate housing is 6 m ($L4$). When ordering a device with a separate housing, the desired length must be specified.
- Maximum total length: $L1 + L4 = 10$ m
- If the connecting cable is to be shortened or passed through a wall, it must be separated from the process connection. See "Documentation" → "Operating Instructions" → 80
- For information on ordering, please refer also to "Product structure" → "Probe design" → 5

3.6.1 Extension heights: separate housing

Housing side: wall mounting

Housing side: pipe mounting

Sensor side

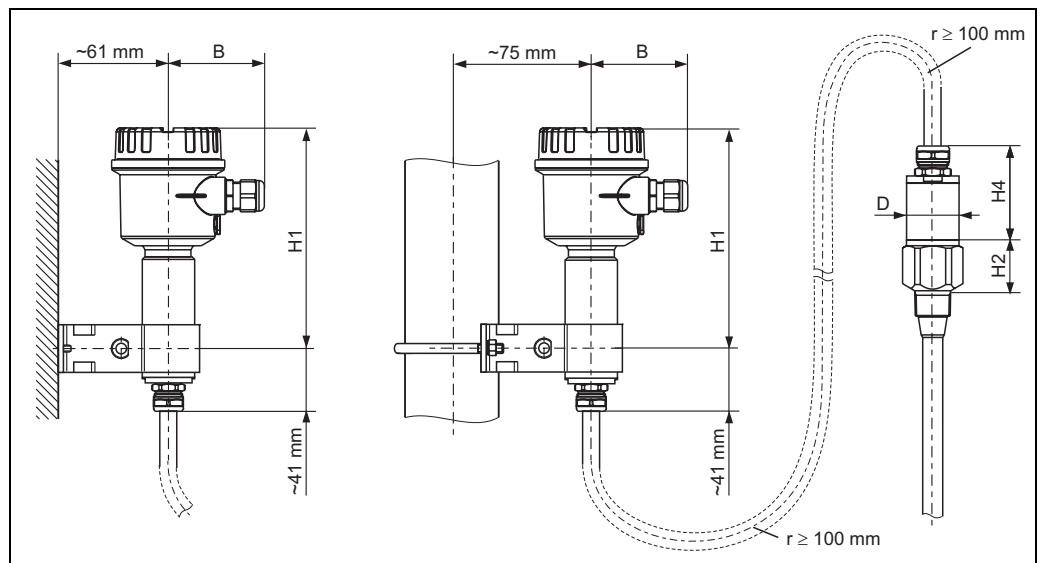

Note!

The bending radius of the connecting cable must be at least $r \geq 100$ mm!

	Polyester housing (F16)	Stainless steel housing (F15)	Aluminum housing (F17)
B (mm)	76	64	65
H1 (mm)	172	166	177

		H4 (mm)	D (mm)
Probes Ø10 mm rod		66	38
Probes Ø16 mm rod or rope (without fully insulated inactive length)	G 1/2", G 3/4", G 1", NPT 1/2", NPT 3/4", NPT 1", Clamp 1", Clamp 1 1/2", Universal Ø44, flange < DN 50, ANSI 2", 10K50	66	38
	G1 1/2", NPT1 1/2", Clamp 2", DIN 11851, flanges ≥ DN 50, ANSI 2", 10K50	89	50
Probes Ø 22 mm rod or rope (with fully insulated inactive length)		89	38



Note!
 Connecting cable: ø10.5 mm
 Outer jacket: silicone, notch resistance

3.6.2 Wall holder unit



- Note!
- The wall holder unit is part of the scope of supply.
 - The wall holder unit has to be screwed to the separate housing before you can use it as a drilling template. The distance between the holes is reduced by screwing it to the separate housing.

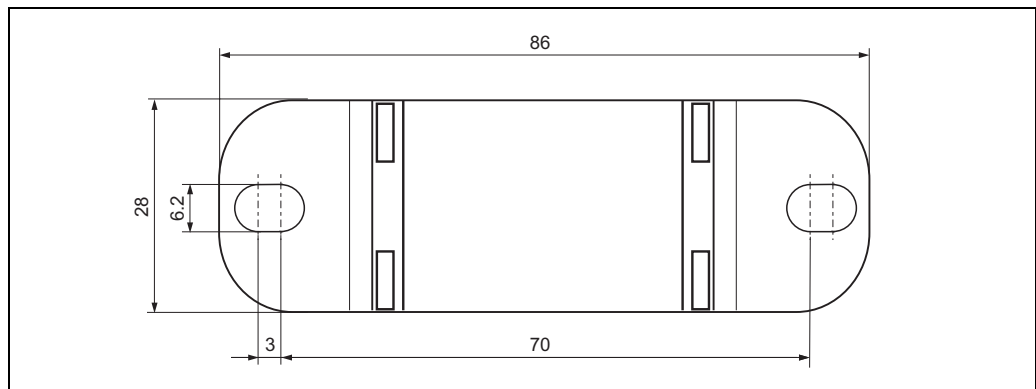

TI418F20

3.6.3 Wall mounting

- Push the bracket onto the sleeve and screw it into place.
- Mark the distance between holes on the wall, then drill the holes.
- Screw the separate housing to the wall.

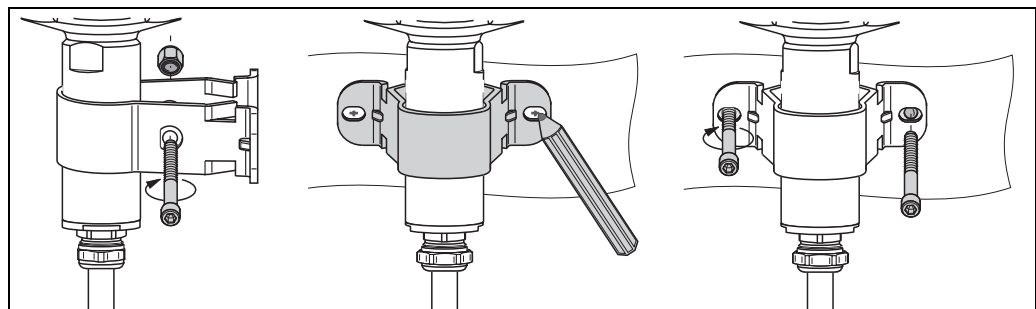

L00-FM15xxxx-03-05-xx-xx-010

3.6.4 Pipe mounting

- Push the bracket onto the sleeve and screw it into place.
- Screw the separate housing to the pipe (max. 2").

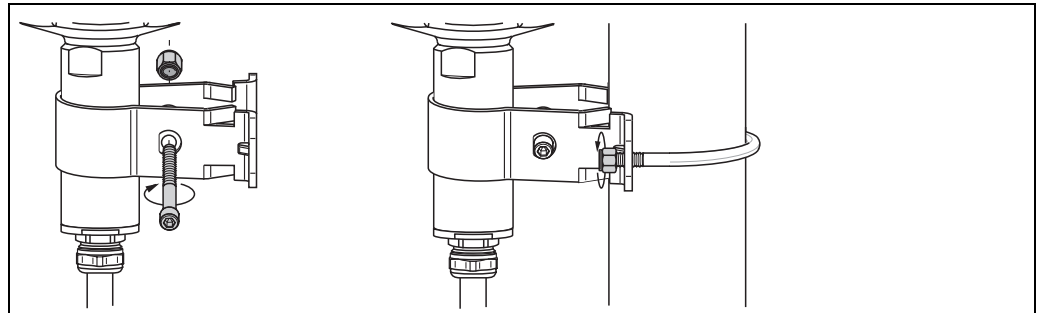

L00-FMI5xxxx-03-05-xx-xx-011

3.7 Probe without active buildup compensation

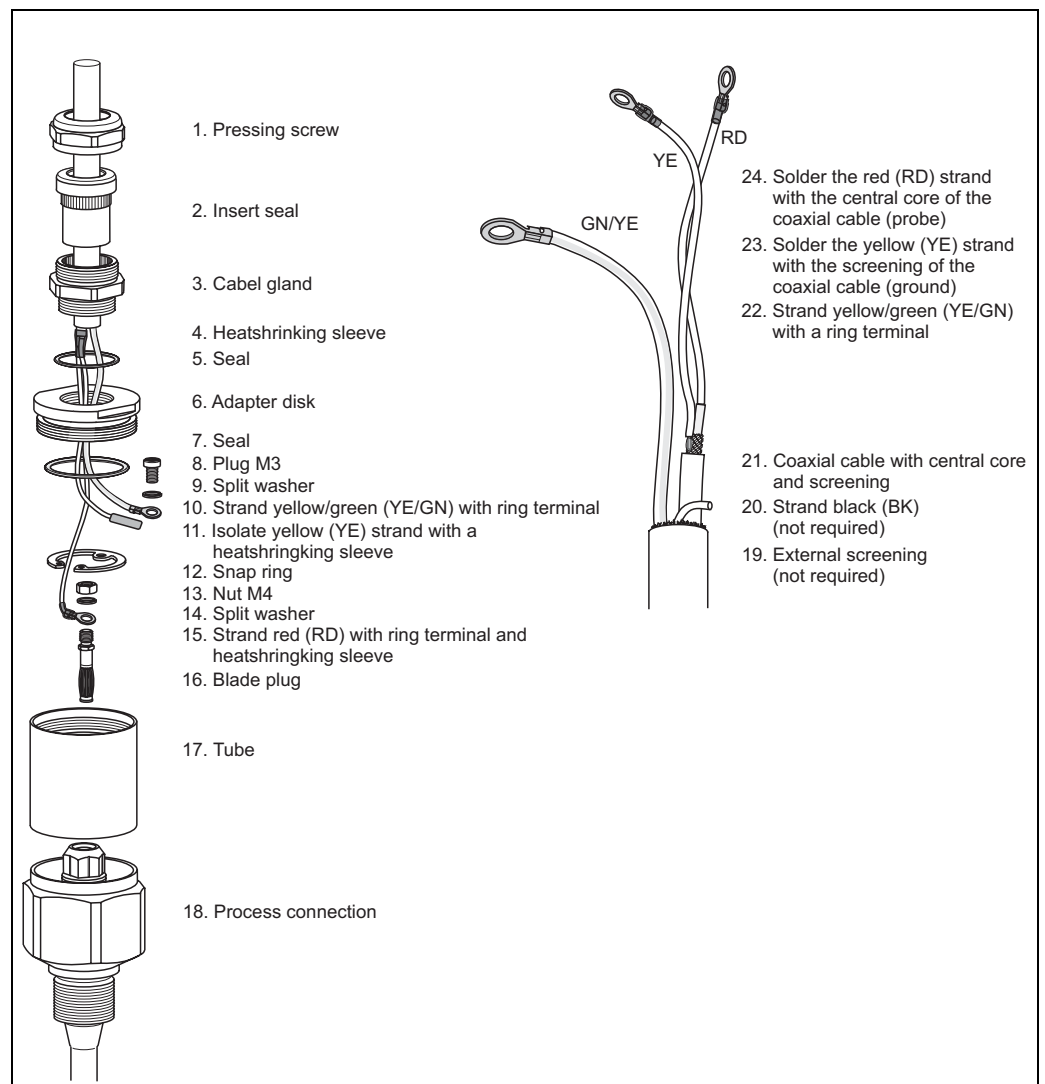

L00-FMI5xxxx-03-05-xx-xx-en-005

3.7.1 Shortening the connecting cable



Caution!

A recalibration must be performed before commissioning → 46ff.



Note!

The maximum connection length between the probe and the separate housing is 6 m. When ordering a device with a separate housing, the desired length must be specified.

If the connecting cable is to be shortened or passed through a wall, it must be separated from the process connection. To do so, proceed as follows:

- Unscrew the pressing screw (1) using an open-end wrench AF22. If necessary, hold the process connection. In doing so, ensure that neither the connecting cable nor the probe is turned in the process.
- Pull the insert seal (2) out of the cable gland (3).
- Using an open-end wrench (AF22), disconnect the cable gland (3) from the adapter disk. If necessary, hold it against the adapter disk (6) using an open-end wrench AF34.
- Disconnect the adapter disk (6) from the adapter bushing (18).
- Remove the snap ring with a snap ring pliers.
- Grip the nut (M6) on the blade plug with a pliers and pull out the blade plug.
- Then, shorten the connecting cable to the desired length.
- If the separate housing has to be mounted in a different room than the probe, you can now route the connecting cable through the wall.
- You can now reassemble the device by following the reverse order of steps.



Note!

- If you shorten the connecting cable, we recommend reusing all strands with ring terminals.
- If the strands are not to be reused, the crimp connections of the new ring terminals attached must be insulated with a heat-shrinking sleeve tube, for example (danger of short circuit).
- All soldered joints must be insulated. Use heat-shrinking sleeves to do so.

3.8 Probe with active buildup compensation

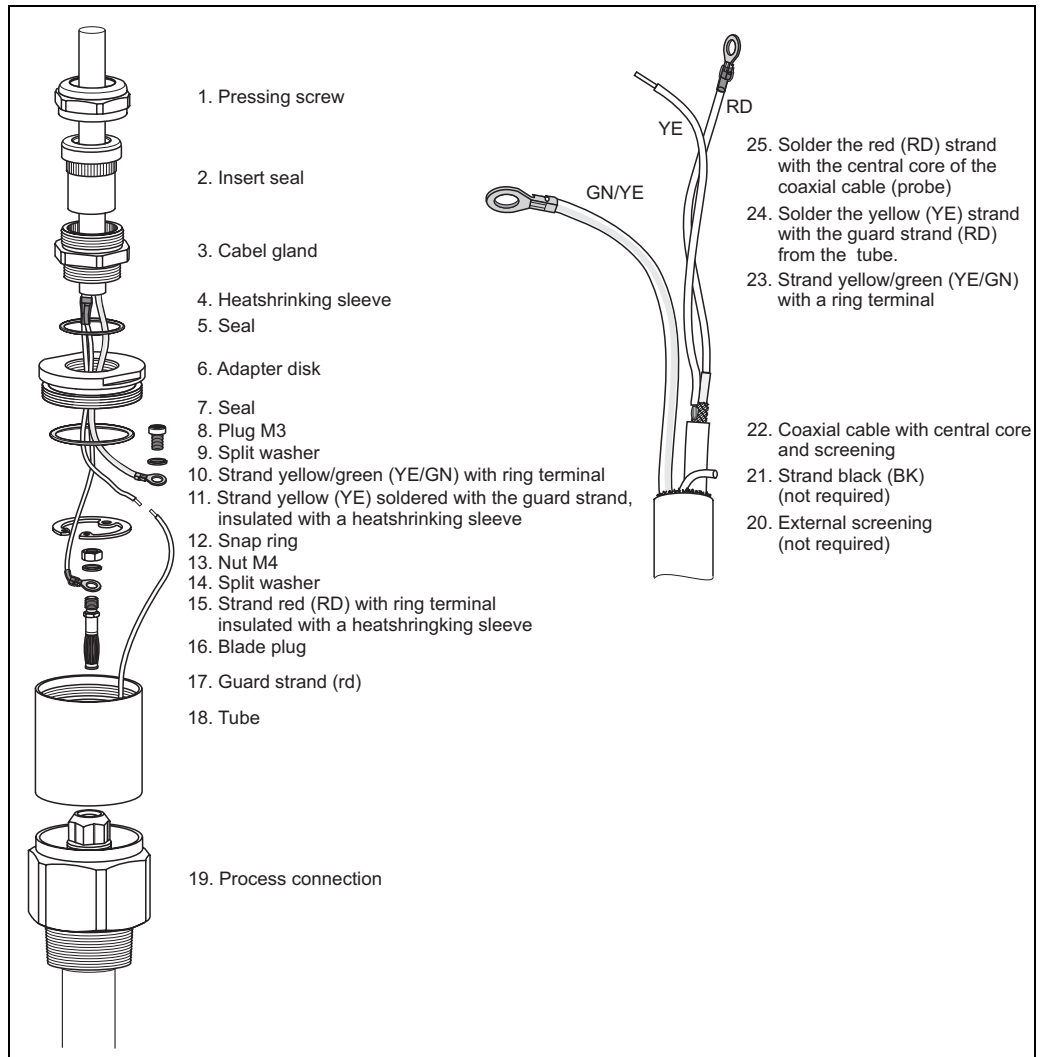

L00-FMI5xxxx-03-05-xx-en-008

3.8.1 Shortening the connecting cable

A recalibration must be performed before commissioning →  46.



Note!

The maximum connection length between the probe and separate housing is 6 m and is indicated by dimension L4. When ordering a device with a separate housing, the connection length must be specified.

If the connecting cable is to be shortened or guided through a wall, it must be disconnected from the process connection. To do so, proceed as follows:

- Unscrew the pressing screw (1) using an open-end wrench AF22. If necessary, hold the process connection. In doing so, ensure that neither the connecting cable nor the probe is turned in the process.
- Pull the insert seal (2) out of the cable gland (3).
- Using an open-end wrench (AF22), disconnect the cable gland (3) from the adapter disk. If necessary, hold it against the adapter disk (6) using an open-end wrench AF34.
- Disconnect the adapter disk (6) from the sleeve (17).
- Remove the snap ring using a snap ring pliers.
- Using pliers, grab the nut (M6) on the Multilam plug and pull out the plug.
- Disconnect the connection between the yellow and red (guard) wires.
- Then, shorten the connecting cable to the desired length. If the separate housing is in a different room than the probe, you can now route the connecting cable through the wall.
- You can now reassemble the device by following the reverse order of steps.



Note!

- If you shorten the connecting cable, we recommend reusing all strands with ring terminals.
- If the wires are not reused, the crimp connections of the newly attached eyelets must be insulated, for example using a heat-shrinking sleeve (danger of short circuit).
- All soldered joints must be insulated.

3.9 Installation conditions



Caution!

- Do not damage the probe insulation during installation.
- Do not turn the housing while screwing in the probe, as otherwise the housing fixture can be damaged.

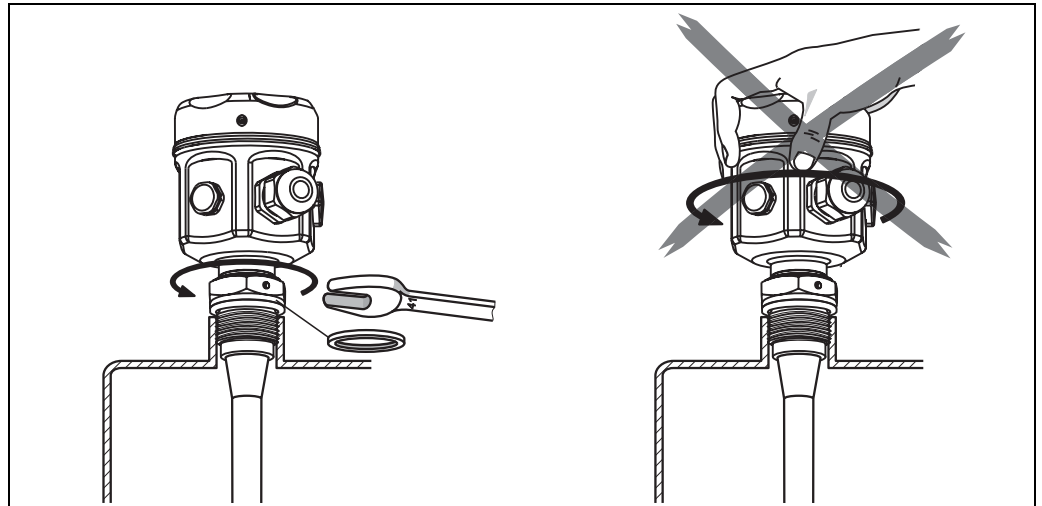

100-FMI5xxxx-17-00-00-xx-003

Probe with thread

G ½, G ¾, G 1 or G 1½ (cylindrical):

To be used with the enclosed elastomer fiber seal (temperature-resistant up to 300 C) or another chemically resistant seal.



Note!

The following applies to probes with parallel threads and included seals:

Thread	For pressures up to 25 bar	For pressures up to 100 bar	Maximum tightening torque
G ½	25 Nm	-	80 Nm
G ¾	30 Nm	-	100 Nm
G 1	50 Nm	-	180 Nm
G 1½	-	300 Nm	500 Nm

½ NPT, ¾ NPT, 1 NPT and 1½ NPT (conical):

Wrap thread in suitable seal material (e.g. Teflon) (note conductivity).

Probe with Tri-Clamp, sanitary connection or flange

The process seal must meet the specifications of the application (resistant to temperature and medium).

If the flange is PTFE-clad, this is generally a sufficient seal up to the permitted operating pressure.

3.9.1 Installation tools

The following tools are required for installation:

- Tool for mounting flanges
- Or a size 41 or size 55 Allen key for the threaded connection and
- A Phillips-head screwdriver for aligning the cable entry.

3.9.2 Aligning the housing

To align the cable entry, the housing can be rotated by 270°.

For protection against ingress of moisture, particularly for outdoor installation, we recommend routing the connecting cable downwards in front of the cable gland and securing it with a cable tie.

Housing

- Screw open the cover.
- Unscrew the Phillips-head screw at the bottom of the housing by 3 to 4 complete turns.
- Rotate the housing into the desired position (max. 270°, from one limit stop to the other)
- Tighten the Phillips-head screw at the bottom of the housing.



Note!

For the Type T13 housing with separate connection compartment, the Phillips-head screw for aligning the housing is also in the electronics compartment.

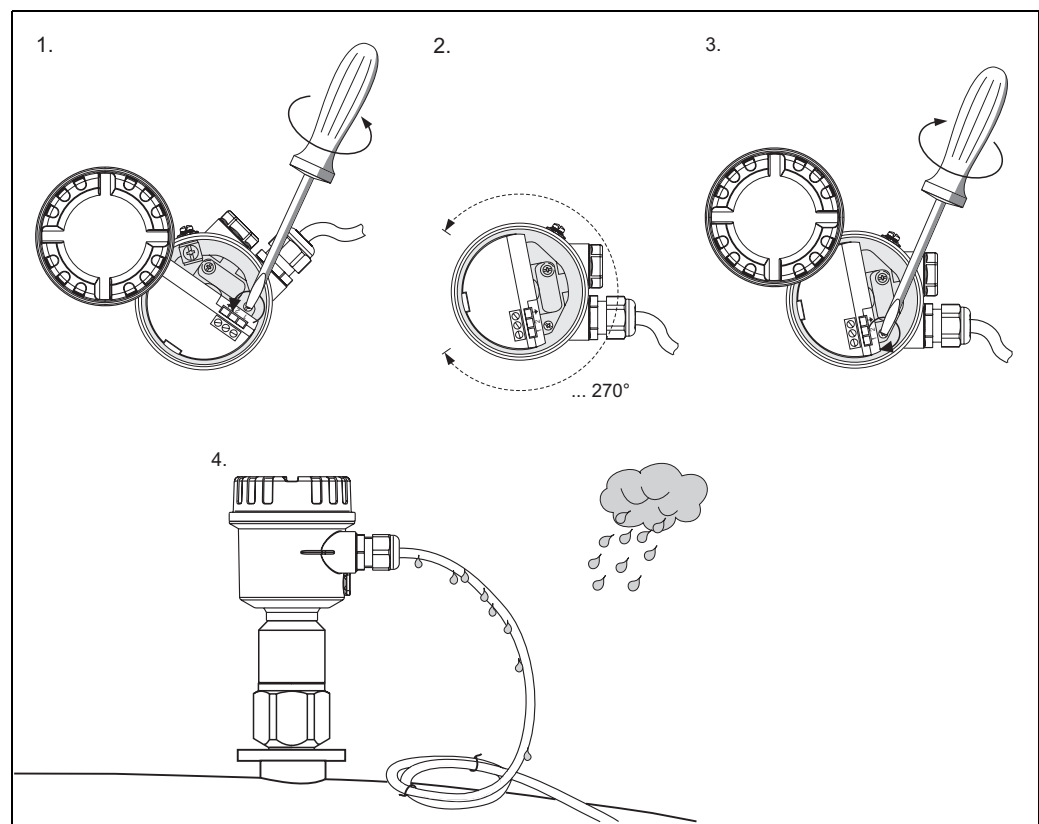

L00-FM15xxxx-04-00-00-xx-002

1. Release the securing screw in the housing until the housing rotates easily.
2. Align the housing as required.
3. Tighten the securing screw (< 1 Nm) until the housing can no longer be turned.
4. Also protect the electronics compartment against moisture.

3.9.3 Sealing the probe housing

No water should enter the device when performing installation, connection and configuration tasks. Always seal the housing cover and cable entries securely.

The O-ring seal on the housing cover is shipped with a coat of special lubricant applied. This allows the cover to seal tightly and ensures that the aluminum thread does not become jammed during closing.

Never use mineral oil-based grease as this destroys the O-ring.

3.10 Post-installation check

After installing the measuring device, carry out the following checks:

- Is the device damaged (visual inspection)?
- Does the device correspond to the measuring point specifications, including process temperature and pressure, ambient temperature, measuring range, etc.?
- Is the process connection tightened with the correct torque?
- Are the measuring point number and labeling correct (visual inspection)?
- Is the measuring device adequately protected from precipitation and direct sunlight?

4 Wiring



Caution!

Before connecting the supply voltage, note the following:

- The supply voltage must match that specified on the nameplate (1).
- Switch off the supply voltage before connecting the device.
- Connect the potential equalization to the ground terminal at the sensor.



Note!

- When using the probe in hazardous areas, the relevant national standards and the information in the safety instructions (XA) must be observed.
- Use the specified cable gland only.

4.1 Connection recommendation

4.1.1 Potential equalization

Connect the potential equalization to the outer ground terminal of the housing (T13, F13, F16, F17, F27). In the case of the stainless steel housing F15, the ground terminal (depending on the version) can also be located in the housing.

For additional safety instructions, refer to the separate documentation for applications in hazardous areas.

4.1.2 Electromagnetic compatibility (EMC)

Interference emission in accordance with EN 61326, Class B electrical device, interference immunity in accordance with EN 61326 appendix A (industrial use) and NAMUR EMC recommendation NE 21.

4.1.3 Cable specification

The electronic inserts can be connected using the usual commercial instrument cables.

When using shielded instrument cables, it is recommended to connect the shielding on both sides to optimize the shielding effect (if potential equalization present).

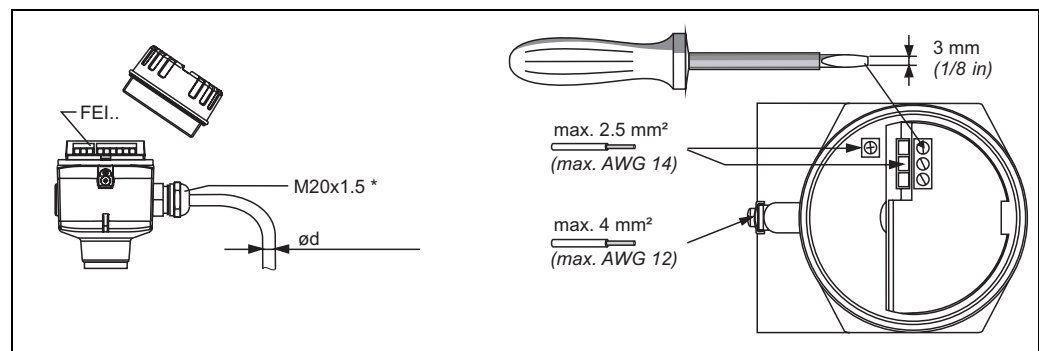

* Cable entries

Nickel-plated brass: $\varnothing d = 7$ to 10.5 mm (0.28 to 0.41 in)

Synthetic material: $\varnothing d = 5$ to 10 mm (0.2 to 0.38 in)

Stainless steel: $\varnothing d = 7$ to 12 mm (0.28 to 0.47 in)

4.1.4 Connector

For the version with a connector M12, the housing does not have to be opened for connecting the signal line.

PIN assignment for M12 connector

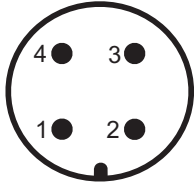
 <p style="text-align: center; font-size: small;">L00-FTI5xxxx-04-00-xx-xx-015</p>	PIN	2-wire-electronic insert FEI55, FEI57, FEI58, FEI50H, FEI57C	3-wire-electronic insert FEI52, FEI53
	1	+	+
	2	not used	not used
	3	-	-
	4	ground	external load / signal

4.1.5 Cable entry

- Cable gland: M20x1.5 (for EEx d only cable entry M20)
Two cable glands included in scope of delivery.
- Cable entry: G ½, NPT ½ and NPT ¾

4.2 Wiring and connecting

Connection compartment

Determining the degree of protection:

Housing	Standard	EEx ia	EEx d	gas-tight process seal
Polyester housing F16	X	X	-	-
Stainless steel housing F15	X	X	-	-
Aluminum housing F17	X	X	-	-
Aluminum housing F13	X	X	X	X
Stainless steel housing F27	X	X	X	X
Aluminum housing T13 (with separate connection compartment)	X	X	X	X

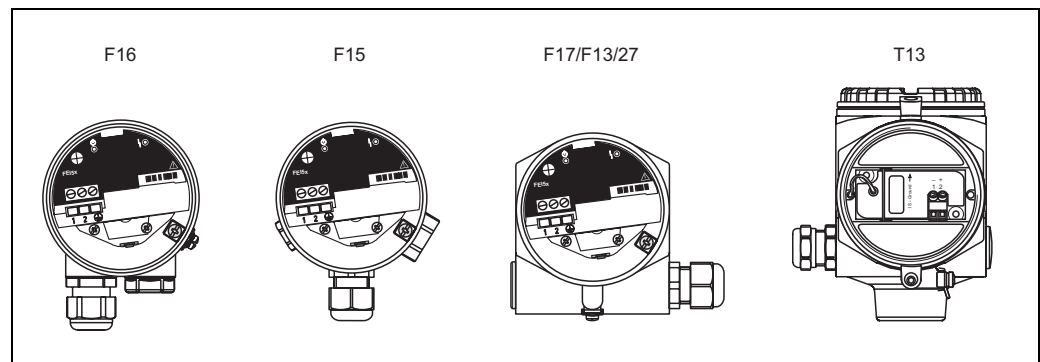

L00-FM15xxxx-04-00-00-xx-001

To connect the electronic insert to the power supply, proceed as follows:

- Unscrew the housing cover (1).
- Remove the cable gland (2) and insert the cable (3).

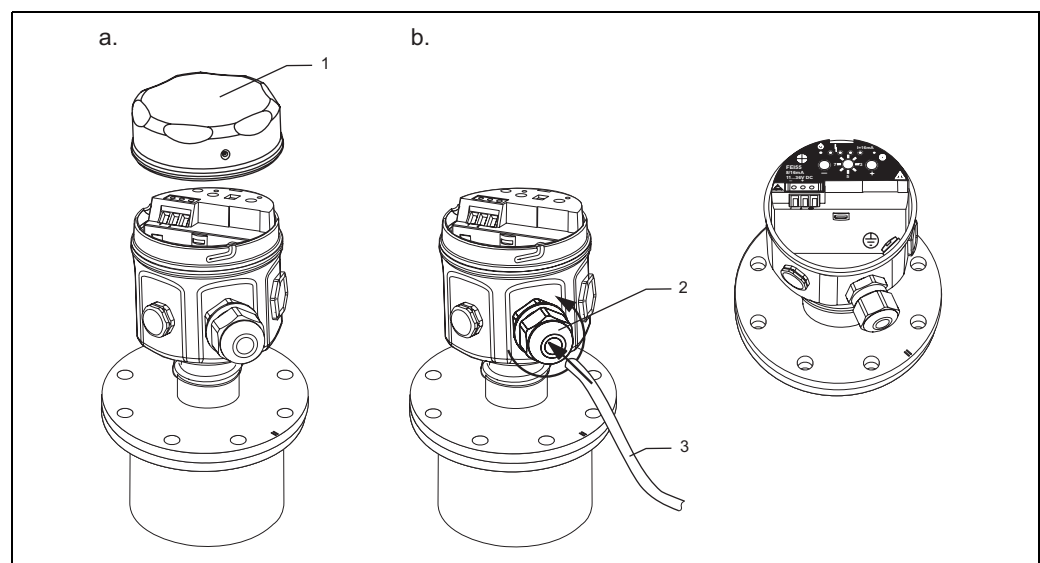

L00-FM15xxxx-04-06-xx-xx-003

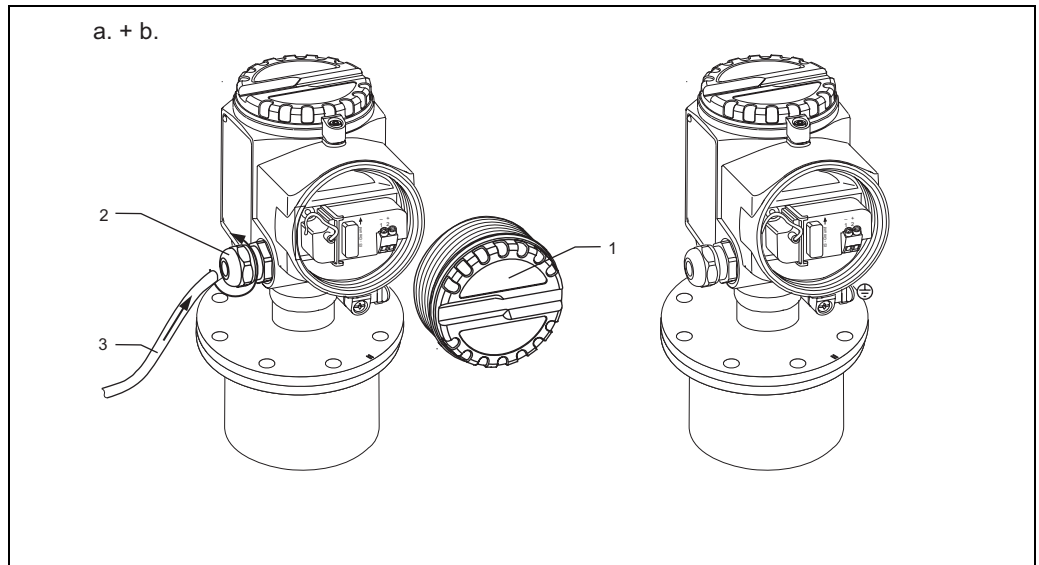
**Note!**

- Information on the procedure for connecting shielded cables is provided in TI241F "EMC test procedures".
- All further steps depend on the specific electronic inserts used, which are described on the following pages:
 - FEI51 → 34
 - FEI52 → 35
 - FEI53 → 36
 - FEI54 → 37
 - FEI55 → 38
 - FEI57S → 39
 - FEI58 → 40

4.3 Connecting the electronic insert FEI51 (AC 2-wire)



Note!
Connect in series with an external load.

Power supply

Supply voltage: 19 to 253 V AC
Power consumption: < 1.5 W
Residual current consumption: < 3.8 mA
Short-circuit protection
Overvoltage category II

Signal on alarm

Output signal on power failure or in the event of damage to the sensor: < 3.8 mA

Connectable load

- For relays with a minimum holding power or rated power > 2.5 VA at 253 V AC (10 mA) or > 0.5 VA at 24 V AC (20 mA)
- Relays with a lower holding power or rated power can be operated by means of an RC module connected in parallel.
- For relays with a maximum holding power or rated power < 89 VA at 253 V AC or < 8.4 VA at 24 V AC
- Voltage drop across FEI51 max. 12 V
- Residual current with blocked thyristor max. 3.8 mA
- Load switched directly into the power supply circuit via the thyristor.

Connect the FEI51 (AC 2-wire) as follows:

1. Make the connection as shown in the graphic.
2. Tighten the cable gland.
3. Set the function switch (5) to position 1 (operation).

Note!

Do not switch on the supply voltage until you have familiarized yourself with the device functions as described in Section 5 "Operation". This will ensure that you do not accidentally trigger any processes by switching on the supply voltage.

4. Switch on the supply voltage.

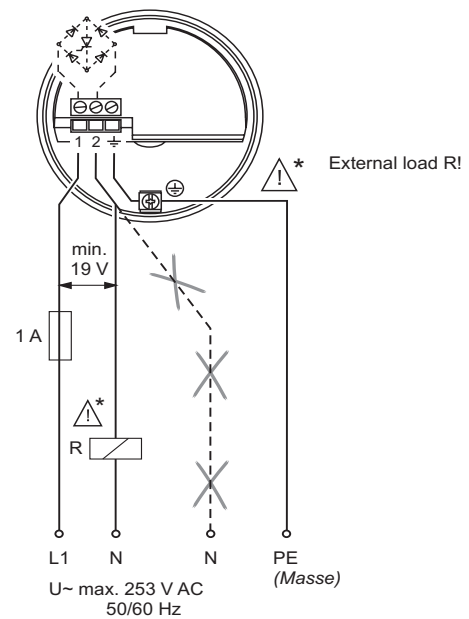

L00-FM15xxxx-06-05-xx-es-071

4.4 Connecting the electronic insert FEI52 (DC PNP)

The three-wire DC connection should, wherever possible, be connected as follows:

- To programmable logic controllers (PLCs),
- to DI modules in accordance with EN 61131-2

A positive signal is present at the switch output of the electronic system (PNP).

Power supply

Supply voltage: 10 to 55 V DC

Ripple: max. 1.7 V; 0 to 400 Hz

Current consumption: < 20 mA

Power consumption without load: max. 0.9 W

Power consumption with full load (350 mA): 1.6 W

Reverse polarity protection: yes

Separation voltage: 3.7 kV

overvoltage category II

Signal on alarm

Output signal on power failure or in the event of device failure: $I_R < 100 \mu\text{A}$

Connectable load

- Load switched via transistor and separate PNP connection, max. 55 V
- Load current max. 350 mA (cyclical overload and short-circuit protection)
- Residual current < 100 μA (with transistor blocked)
- Capacitance load max. 0.5 μF at 55 V; max. 1.0 μF at 24 V
- Residual voltage < 3 V (for transistor switched through)

Connect the FEI52 (DC PNP) as follows:

1. Make the connection as shown in the graphic.
2. Turn the cable gland until tight.
3. Set the function switch to position 1 (operation).



Note!

Do not switch on the supply voltage until you have familiarized yourself with the device functions as described on → 42 "Operation". This will ensure that you do not accidentally trigger any processes by switching on the supply voltage.

4. Switch on the supply voltage.

* R = External load ($I_{\text{max.}}$ 350 mA, U_{max} 55 V DC)

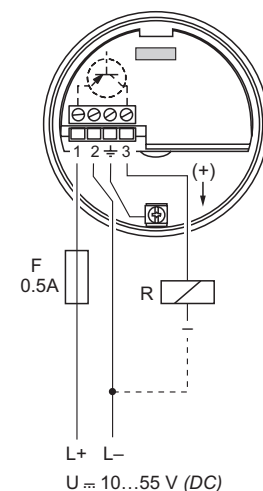

TI418F42

4.5 Connecting the electronic insert FEI53 (3-WIRE)

The 3-wire DC connection is used in conjunction with the Nivotester switching device FTC325 3-WIRE from Endress+Hauser. The switching device's communication signal operates at 3 to 12 V.

The failsafe mode (MIN) / (MAX) and the point level adjustment are configured on the Nivotester.

Power supply

Supply voltage: 14.5 V DC

Current consumption: < 15 mA

Power consumption: max. 230 mW

Reverse polarity protection: yes

Separation voltage: 0.5 kV

Signal on alarm

Voltage at terminal 3 vis-à-vis terminal 1: < 2.7 V

Connectable load

- Floating relay contacts in the connected switching unit Nivotester FTC325 3-WIRE
- For the contact load capacity, refer to the technical data of the switching device.

Connect the FEI53 (3-WIRE) as follows:

1. Make the connection as shown in the graphic.
2. Turn the cable gland until tight.

 **Note!**

Do not switch on the supply voltage until you have familiarized yourself with the device functions as described on Seite 42 "Operation". This will ensure that you do not accidentally trigger any processes by switching on the supply voltage.

3. Switch on the supply voltage.

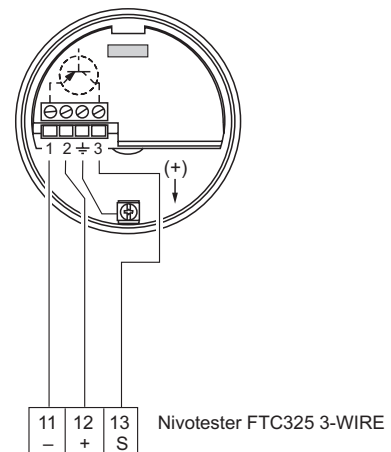

TI418F43

4.6 Connecting the electronic insert FEI54 (AC/DC with relay output)

The universal voltage connection with relay output (DPDT) operates in two different voltage ranges (AC and DC).



Note!

When connecting devices with a high inductance, use a spark suppression system to protect the relay contacts.

Power supply

Supply voltage: 19 to 253 V AC, 50/60 Hz or 19 to 55 V DC

Power consumption: max. 1.6 W

Reverse polarity protection: yes

Separation voltage: 3.7 kV
overvoltage category II

Signal on alarm

Output signal on power failure or in the event of device failure: relay de-energized

Connectable load

- Loads switched via 2 floating changeover contacts (DPDT)
- I~ max. 6 A; U~ max. 253 V; P~ max. 1500 VA at $\cos \varphi = 1$;
P~ max. 750 VA at $\cos \varphi > 0.7$
- I- max. 6 A to 30 V; I- max. 0.2 A to 125 V
- The following applies when connecting a functional low-voltage circuit with double isolation as per IEC 1010: Sum of voltages of relay output and power supply max. 300 V

Connect the FEI54 (AC/DC relay) as follows:

1. Make the connection as shown in the graphic.
2. Turn the cable gland until tight.
3. Set the function switch to position 1 (operation).



Note!

Do not switch on the supply voltage until you have familiarized yourself with the device functions as described on Seite 42 "Operation". This will ensure that you do not accidentally trigger any processes by switching on the supply voltage.

4. Switch on the supply voltage.

* Refer also to Connectable load

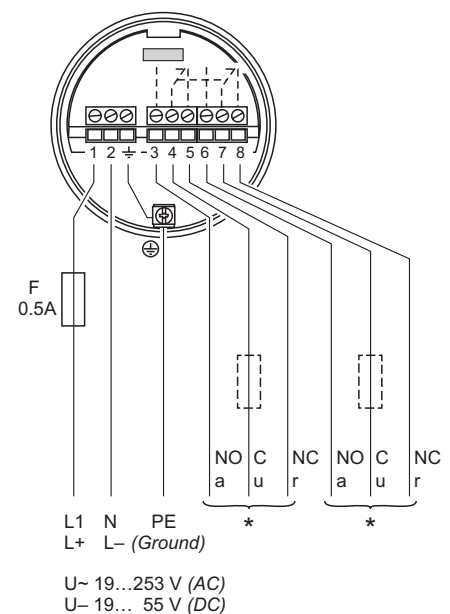

TI418F47

4.7 Connecting the electronic insert FEI55 (8/16 mA; SIL2/SIL3)

The two-wire DC connection should, if possible, be connected as follows:

- To programmable logic controllers (PLCs),
- to AI modules 4 to 20 mA in accordance with EN 61131-2

The point level signal is sent via an output signal jump from 8 mA to 16 mA.

Power supply

Supply voltage: 11 to 36 V DC
 Power consumption: < 600 mW
 Reverse polarity protection: yes
 Separation voltage: 0.5 kV

Signal on alarm

Output signal on power failure or in the event of device failure: < 3.6 mA

Connectable load

- U = connection DC voltage:
 - 11 to 36 V DC (non-hazardous area and Ex ia)
 - 14.4 to 30 V DC (Ex d)
- $I_{\max} = 16 \text{ mA}$

Connect the FEI55 (8/16 mA) as follows:

1. Make the connection as shown in the graphic.
2. Turn the cable gland until tight.
3. Set the function switch to position 1 (operation).

 **Note!**

Do not switch on the supply voltage until you have familiarized yourself with the device functions as described on Seite 42 "Operation". This will ensure that you do not accidentally trigger any processes by switching on the supply voltage.

4. Switch on the supply voltage.

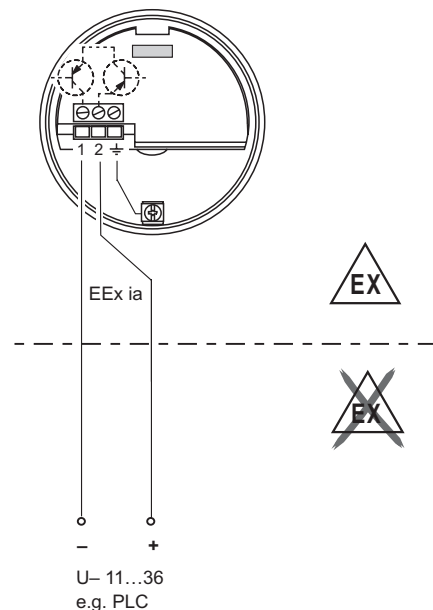

T1418Fen50

Functional safety (SIL)

The electronic insert FEI55 meets the requirements of SIL2/SIL3 in accordance with IEC 61508/IEC 61511-1 and can be used in safety systems with corresponding requirements.

An exact description of the requirements in terms of functional safety can be found in document SD278F/00.

4.8 Connecting the electronic insert FEI57S (PFM)

The two-wire DC connection is used in conjunction with one of the following Nivotester switching devices from Endress+Hauser:

- FTC325 PFM,
- FTC625 PFM (from SW V1.4),
- FTC470Z,
- FTC471Z

The PFM signal is between 17 and 185 Hz.

The failsafe mode (MIN) / (MAX) and the point level adjustment are configured on the Nivotester.

Power supply

Supply voltage: 9.5 to 12.5 V DC

Power consumption: < 150 mW

Reverse polarity protection: yes

Separation voltage: 0.5 kV

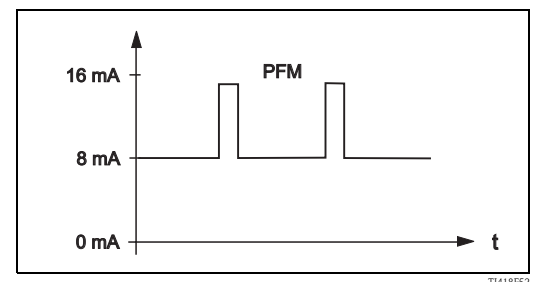

Frequency: 17 to 185 Hz

Output signal

PFM 17 to 185 Hz (Endress+Hauser)

Connectable load

- Floating relay contacts in the connected switching unit Nivotester FTC325 PFM, FTC625 PFM (from SW V1.4), FTC470Z, FTC471Z
- For the contact load capacity, refer to the technical data of the switching device.

Connect the FEI57 (PFM) as follows:

1. Make the connection as shown in the graphic.
2. Turn the cable gland until tight.



Note!

Do not switch on the supply voltage until you have familiarized yourself with the device functions as described on Seite 42 "Operation". This will ensure that you do not accidentally trigger any processes by switching on the supply voltage.

3. Switch on the supply voltage.

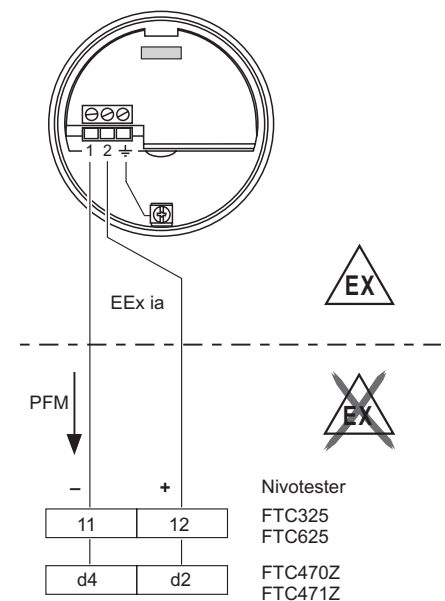

T1418F53

4.9 Connecting the electronic insert FEI58 (NAMUR)

The two-wire connection for a separate switching unit in accordance with NAMUR specifications (IEC 60947-5-6), e.g. FXN421, FXN422, FTL325N, FTL375N from Endress+Hauser. Change in output signal from high to low current in event of point level detection.

(H-L edge)

Additional function:

Test key on the electronic insert.

Pressing the key breaks the connection to the isolating amplifier.



Note!

In the case of Ex-d operation, the additional function can only be used if the housing is not exposed to an explosive atmosphere.

When connecting to Multiplexer: set 3 s as the cycle time at least.

Power supply

Power consumption: < 6 mW at $I < 1 \text{ mA}$; < 38 mW at $I = 2.2 \text{ to } 4 \text{ mA}$

Interface connection data: IEC 60947-5-6

Signal on alarm

Output signal in the event of damage to the sensor: < 1.0 mA

Connectable load

- See the technical data of the connected isolating amplifier as per IEC 60947-5-6 (NAMUR)
- Connection also to isolating amplifiers which have special safety circuits ($I > 3.0 \text{ mA}$)

Connect the FEI58 (NAMUR) as follows:

1. Make the connection as shown in the graphic.
2. Tighten the cable gland.



Note!

Do not switch on the supply voltage until you have familiarized yourself with the device functions as described on Seite 42 "Operation". This will ensure that you do not accidentally trigger any processes by switching on the supply voltage.

3. Switch on the supply voltage.

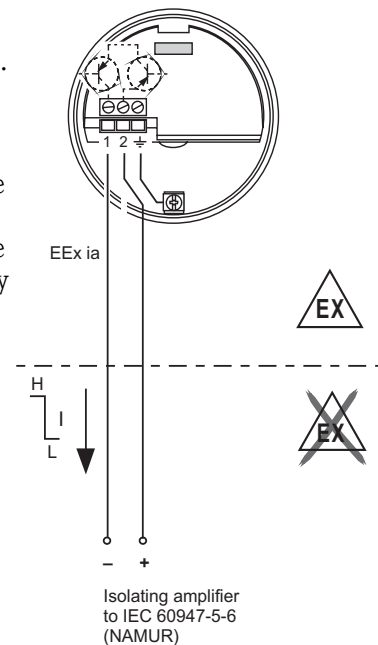

L00-FTI5xxxx-04-05-xx-en-002

4.10 Post-connection check

After wiring the measuring device, carry out the following checks:

- Is the terminal assignment correct?
- Is the cable gland tightly sealed?
- Is the housing cover screwed on all the way?
- If a power supply is present:
 - If the device is operational, the green LED flashes at 5-second intervals.

5 Operation

5.1 Human interface and display elements for FEI51, FEI52, FEI54, FEI55

You can operate the electronic inserts FEI51, FEI52, FEI54 and FEI55 via the function switch (A) and the "-" (B) and "+" (C) keys.

The function switch A has eight possible positions. Each position has at least one function. The operating status of the device is indicated by light emitting diodes (LEDs 1 to 6) on the electronic insert and depends on the position of the function switch.

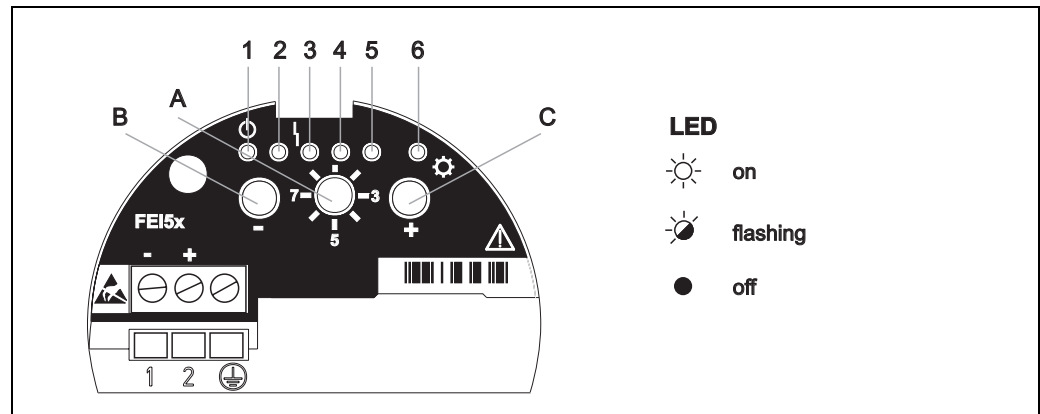















Green LED 1 (☺ ready for operation), red LED 2 (⚡ error indicated), yellow LED 3 (⚙ switching state)



Note!

To select a function, press the keys (- and/or +) for at least 2 seconds. Release the keys when the LED signals change.

Function switch position	Function	- key	+ key	Light emitting diodes (LED signals)					
									
A		B	C	1 (green)	2 (green)	3 (red)	4 (green)	5 (green)	6 (yellow)
1 	Operation			Flashes Operational LED	On*** (MIN-SIL)	Flashes (warning/ alarm)	On*** (MAX-SIL)		On/off/ flashes**
	Restore factory setting	Press both keys for approx. 20 s		On	->	->	->	->	**
2  	Empty calibration	Press		On (present)					**
	Full calibration		Press					On (present)	**
	Reset: Calibration and switchpoint adjustment	Press both keys for approx. 10 s		On	->	->	->	->	**
3 	Switch point adjustment	Press for <	Press for >	On * (2 pF)	Off (4 pF)	Off (8 pF)	Off (16 pF)	Off (32 pF)	**
4 	Measuring range	Press for <		On * (500 pF)	Off (1600 pF)				**
	Two-point control Δs		Press once					On	
	buildup mode		Press twice				On	On	**
5 	Switching delay	Press for <	Press for >	Off (0.3 s)	On * (1.5 s)	Off (5 s)	Off (10 s)		**
6 	Self-test (function test)	Press both keys		Off * (inactive)				Flashes (active)	**
7	MIN-/MAX Failsafe mode	Press for MIN	Press for MAX	Off (MIN)				On * (MAX)	**
	SIL mode*** lock/unlock	Press both keys			On (MIN-SIL)		On (MAX-SIL)		
8 	Upload/download sensor DAT (EEPROM)	Press for download	Press for upload	Flashes (download)				Flashes (upload)	**

* These settings are factory settings.

** Switch status signaling (on/off/flashing) depends on the mounting location selected and the failsafe mode (MIN/MAX) set.
The LED flashes if a calibration has not yet been carried out.

*** Only in conjunction with electronic insert FEI55 (SIL). The device is in the SIL mode. To change the current settings, the device must be unlocked → 57.

5.2 Human interface and display elements for FEI53, FEI57S

The electronic inserts FEI53 and FEI57S are used in conjunction with Nivotester switching devices. The functions of the DIP switches (A and B) and the LEDs (1 and 2) are described in the table below.

The operating status of the device is indicated by LEDs (LED 1 and 2) on the electronic insert and provides information on operational readiness (1) and, where applicable, the type of fault (2).

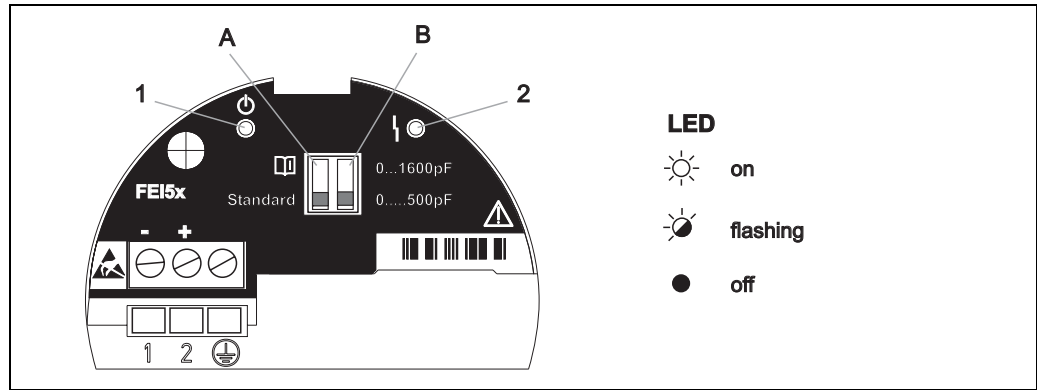

LED 1 operational ☉: Flashes at 5-second intervals.

LED 2 fault ⚡: The red LED flashes if there is a fault that you can correct.

LED 2 fault ⚠: The red LED lights up continuously if the device has a fault that cannot be corrected. See also Seite 71, "Troubleshooting".



Note!

A description of the human interface and display elements of the Nivotester switching device is provided in the documentation that accompanies the device.

DIP switch	Function
A Standard	Standard: If the measuring range is exceeded no alarm is output.
A	⚠: If the measuring range is exceeded an alarm is output.
B 0...500pF	Measuring range: The measuring range is between 0 and 500 pF Span: The span is between 5 and 500 pF.
B 0...1600pF	Measuring range: The measuring range is between 0 and 1600 pF Span: The span is between 5 and 1600 pF.

5.3 Human interface and display elements for FEI58

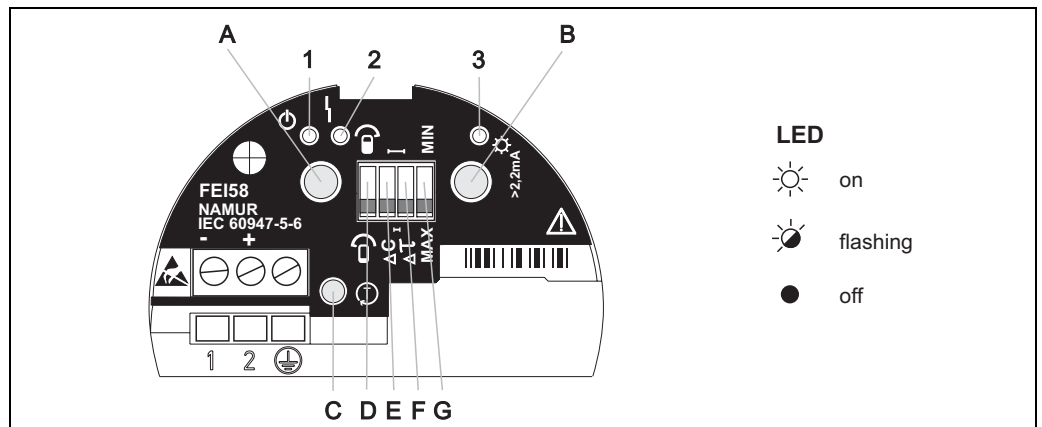

BA299Fen016

Green LED 1 (☉ ready for operation), red LED 2 (⚡ error indicated), yellow LED 3 (* switching state)

DIP switches (C, D, E, F)		Function
D		The probe is covered during calibration.
D		The probe is uncovered during calibration.
E		Switchpoint adjustment: 10 pF
E		Switchpoint adjustment: 2 pF
F		Switching delay: 5 s
F		Switching delay: 1 s
G		Fail-safe mode: MIN The output switches safety-oriented when the probe is uncovered (signal on alarm). For use for dry running protection and pump protection for example
G		Fail-safe mode: MAX The output switches safety-oriented when the probe is covered (signal on alarm). For use with overflow protection for example

Key			Function
A	B	C	
X			Display diagnostic code
	X		Display calibration situation
X	X		Perform calibration (during operation)
X	X		Delete calibration points (during startup)
		X	Test key ☉, (disconnects the transmitter from the switching unit)

6 Commissioning

6.1 Installation and function check

Make sure that the post-installation check and final check have been completed before you start your measuring point:

- For the "Post-installation" checklist, refer to → [29](#).
- For the "Post-connection" checklist, refer to → [41](#).

6.2 Commissioning the electronic inserts FEI51, FEI52, FEI54, FEI55

This chapter describes the process for commissioning the device with electronic inserts FEI51, FEI52, FEI54, FEI55.



Note!

- When you start up the device for the first time, the output is in safe status. This is signaled by the flashing yellow LED 6.
- The device is not operational until you have carried out a calibration. To attain maximum operational safety, carry out an empty and a full calibration. This is particularly recommended for critical applications.





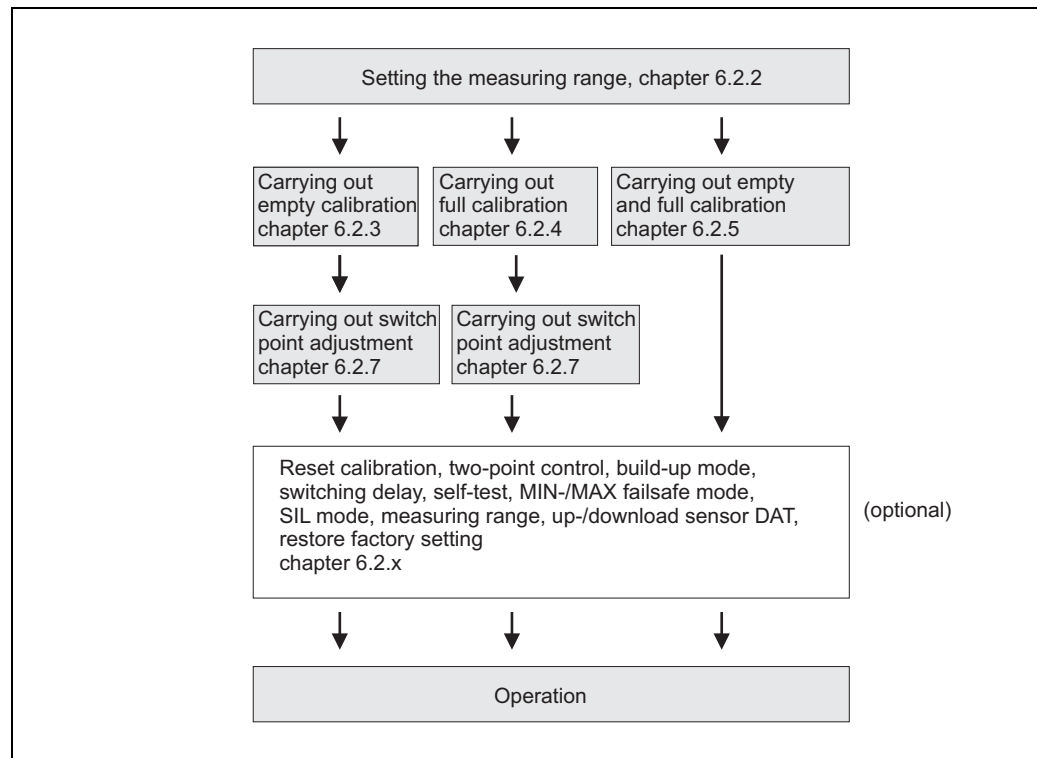









Refer to the following subchapters for information on how to carry out the calibration.

6.2.1 Basic settings: overview



BA381Fen027

6.2.2 Setting the measuring range

Function switch position	Function	- key	+ key	Light emitting diodes (LED signals)					
									
 A		 B	 C	 1 (green)	 2 (green)	 3 (red)	 4 (green)	 5 (green)	 6 (yellow)
4	Measuring range	Press for <		On * (500 pF)	Off (1600 pF)				**

* These settings are factory settings.

** Switch status signaling (on/off/flashing) depends on the mounting location selected and the failsafe mode (MIN/MAX) set.
The LED flashes if a calibration has not yet been carried out.



Note!

The choice of measuring range (0 to 500 pF and 0 to 1600 pF) depends on the function of the probe.

















- If the probe is used as a point level switch, you can retain the factory setting of 0 to 500 pF.
- If the probe is used for two-point control, the following recommendations apply for vertical installation:
 - Measuring range from 0 to 500 pF for probe lengths up to 1 m
 - Measuring range from 0 to 1600 pF for probe lengths up to 10 m

To set the range to 0 to 1600 pF, proceed as follows:

1. Turn the function switch to position 4.
2. Press the "-" key for at least 2 seconds until the green LED 2 lights up.
3. Release the "-" key when the green LED 2 lights up.

Turn the function switch to position 2 to continue the calibration.

6.2.3 Carrying out empty calibration

Function switch position	Function	- key	+ key	Light emitting diodes (LED signals)					
									
 A		 B	 C	 1 (green)	 2 (green)	 3 (red)	 4 (green)	 5 (green)	 6 (yellow)
2 	Empty calibration	Press		On (present)					**

** Switch status signaling (on/off/flashing) depends on the mounting location selected and the failsafe mode (MIN/MAX) set. The LED flashes if a calibration has not yet been carried out.



Note!















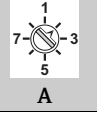

- The empty calibration stores the capacitance value of the probe when the tank is empty. If the measured capacitance value is, for example, 50 pF (empty calibration), a switching threshold of 2 pF is added to this value. The capacitance value of the switch point would, in this case, be 52 pF.
- The switching threshold depends on the value set for the switch point adjustment (for more information, see →  52).

To carry out an empty calibration, proceed as follows:

1. Check to make sure that the probe is not covered with product.
2. Turn the function switch to position 2.
3. Press the "-" key for at least two seconds.
4. Release the "-" key when the green LED 1 starts to flash.

The process of saving the empty calibration is finished when the green LED 1 lights up continuously. You can turn the function switch back to position 1 to return to operation.

6.2.4 Carrying out full calibration

Function switch position	Function	- key	+ key	Light emitting diodes (LED signals)					
									
 A		 B	 C	 1 (green)	 2 (green)	 3 (red)	 4 (green)	 5 (green)	 6 (yellow)
2 	Full calibration		Press					On (present)	**

** Switch status signaling (on/off/flashing) depends on the mounting location selected and the failsafe mode (MIN/MAX) set. The LED flashes if a calibration has not yet been carried out.



Note!

















- The full calibration measures the capacitance value of the probe when the tank is full. If the measured capacitance value is, for example, 100 pF (full calibration), a switching threshold of 2 pF is subtracted from this value. The capacitance value of the switch point is thus 98 pF.
- The switching threshold depends on the value set for the switch point adjustment (for more information, see → [52](#)).

To carry out a full calibration, proceed as follows:

1. Make sure that the probe is covered by the medium up to the desired switch point.
2. Turn the function switch to position 2.
3. Press the "+" key for at least two seconds.
4. Release the "+" key when the green LED 5 starts to flash.

The process of saving the full calibration is complete when the green LED 5 lights up continuously. You can turn the function switch back to position 1 to return to operation.

6.2.5 Carrying out empty and full calibration

Function switch position	Function	- key	+ key	Light emitting diodes (LED signals)					
									
 A		 B	 C	 1 (green)	 2 (green)	 3 (red)	 4 (green)	 5 (green)	 6 (yellow)
2 	Empty calibration	Press		On (present)					**
2 	Full calibration		Press					On (present)	**

** Switch status signaling (on/off/flashing) depends on the mounting location selected and the failsafe mode (MIN/MAX) set.
The LED flashes if a calibration has not yet been carried out.



Note!

- An empty and full calibration provides the greatest possible operational security. This is particularly recommended for critical applications.
- The empty and full calibration measures the capacitance values of the probes when the tank is full and when it is empty. If, for example, the measured capacitance value of the empty calibration is 50 pF and that of the full calibration is 100 pF, the average capacitance value, 75 pF, is stored as the switch point.

To carry out an **empty calibration**, proceed as follows:

1. Check to make sure that the probe is not covered with product.
2. Turn the function switch to position 2.
3. Press the "-" key for at least two seconds.
4. Release the "-" key when the green LED 1 starts to flash.









The process of saving the empty calibration is finished when the green LED 1 lights up continuously. You can turn the function switch back to position 1 to return to operation.

To carry out a **full calibration**, proceed as follows:

1. Make sure that the probe is covered by the medium up to the desired switch point.
2. Turn the function switch to position 2.
3. Press the "+" key for at least two seconds.
4. Release the "+" key when the green LED 5 starts to flash.

The process of saving the full calibration is complete when the green LED 5 lights up continuously. You can turn the function switch back to position 1 to return to operation.

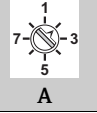
6.2.6 Reset: Calibration and switchpoint adjustment

Function switch position	Function	- key	+ key	Light emitting diodes (LED signals)					
									
 A		 B	 C	1 (green)	2 (green)	3 (red)	4 (green)	5 (green)	6 (yellow)
2	Reset: Calibration and switchpoint adjustment	Press both keys for approx. 10 s		On	->	->	->	->	**

** Switch status signaling (on/off/flashing) depends on the mounting location selected and the failsafe mode (MIN/MAX) set.
The LED flashes if a calibration has not yet been carried out.

















To reset the calibration/switch-point shift (all the other settings remain unchanged), proceed as follows:

1. Turn the function switch to position 2.
2. Press both the "-" and "+" keys for at least 10 seconds.
3. The green LEDs 1-5 light up in succession.

The reset calibration has been carried out and saved. The yellow LED 6 flashes.
The device is not operational until you have carried out a new calibration.

The switch point adjustment is reset to the factory setting of 2 pF.

6.2.7 Setting the switch point adjustment

Function switch position	Function	- key	+ key	Light emitting diodes (LED signals)					
									
 A		 B	 C	 1 (green)	 2 (green)	 3 (red)	 4 (green)	 5 (green)	 6 (yellow)
3 	Switch point adjustment	Press for <	Press for >	On * (2 pF)	Off (4 pF)	Off (8 pF)	Off (16 pF)	Off (32 pF)	**

* These settings are factory settings.

** Switch status signaling (on/off/flashing) depends on the mounting location selected and the failsafe mode (MIN/MAX) set. The LED flashes if a calibration has not yet been carried out.



Note!















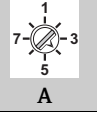

- If only one calibration (empty or full) was carried out, and if buildup forms on the rod probe while the probe is in operation, the device may no longer respond to changes in level. A switch point adjustment (e.g. 4, 8, 16, 32 pF) compensates for this condition and ensures that you obtain a constant switch point again.
- For media that do not have a tendency to build up, we recommend a setting of 2 pF, as the probe is most sensitive to changes in level at this setting.
- For media with heavy buildup (e.g. plaster), we recommend using probes with active buildup compensation.
- A switch point adjustment can be carried out only if a full **or** empty calibration has been carried out first.
- A switch point adjustment is not possible if an empty **and** a full calibration have been carried out.
- The switch point adjustment is disabled if you switch on the two-point control (as described on Seite 53).

To adjust the switch point, proceed as follows:

1. Turn the function switch to position 3.
The green LED 1 lights up (factory setting).
2. Press the "+" key for at least two seconds to switch to the next higher value. If you press and hold down the "+" or "-" key, the value changes to the next one every two seconds. The active value is indicated by an LED (1 to 5).

After you have carried out the switch point adjustment, turn the function switch to position 1 to return to operation.

6.2.8 Configuring two-point control and buildup mode

Function switch position	Function	- key	+ key	Light emitting diodes (LED signals)					
									
 A									
4 	Two-point control Δs		Press once	1 (green)	2 (green)	3 (red)	4 (green)	5 (green)	6 (yellow)
	buildup mode		Press twice				On	On	**

* These settings are factory settings.

** Switch status signaling (on/off/flashing) depends on the mounting location selected and the failsafe mode (MIN/MAX) set. The LED flashes if a calibration has not yet been carried out.



Note!















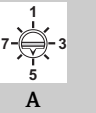

- You can also use the probe rod of a fully insulated and vertically installed probe for pump control (two-point control). The switch points of the empty **and** full calibration activate a conveyor unit, for example. If you want to use the two-point control, please note the following:
 - Set the necessary measuring range. For more information, see Seite 47: "Setting the measuring range".
 - Perform empty and full calibration.
 - Set the failsafe mode (MIN/MAX) in accordance with your requirements. For more information, see Seite 56.
- If you switch on the two-point control (Ds- mode), the switch point adjustment (as described on Seite 52) is disabled. The switch points correspond to the calibration points.
- The "Buildup mode" ensures that a safe switch point is output even if the probe is not fully released from the conductive medium (> 1000 $\mu\text{S}/\text{cm}$ e.g. sewage sludge). Deposits or buildup on the rod/rope are compensated for.

To configure the two-point control and/or buildup mode, proceed as follows:

1. Turn the function switch to position 4.
2. Press the "+" key for at least two seconds to switch on the **two-point control**. The green LED 5 lights up.
3. Press the "+" key again for at least two seconds to switch on the **buildup mode**. Green LEDs 4 and 5 light up. Pressing the "+" again for at least two seconds switches off both functions. Green LEDs 4 and 5 are off.
4. After you have configured the desired setting, turn the function switch to position 1 to return to operation.

You have now completed the settings for the two-point control and buildup mode.

6.2.9 Setting the switching delay

Function switch position	Function	- key	+ key	Light emitting diodes (LED signals)					
									
 A				 1 (green)	 2 (green)	 3 (red)	 4 (green)	 5 (green)	 6 (yellow)
5 	Switching delay	Press for <	Press for >	Off (0.3 s)	On * (1.5 s)	Off (5 s)	Off (10 s)		**

* These settings are factory settings.

** Switch status signaling (on/off/flashing) depends on the mounting location selected and the failsafe mode (MIN/MAX) set.
The LED flashes if a calibration has not yet been carried out.



Note!

- The switching delay causes the device to signal the point level after a delay. This is particularly useful in tanks with turbulent medium surfaces caused, for example, by the filling process or by collapsing mounds. By doing so, you ensure that the filling of the tank does not end until the probe is continuously covered by the medium.
- A switching delay that is too short may, for example, cause the filling process to be restarted as soon as the medium surface settles.



Caution!

If too long of a switching delay is set, this can cause the tank to overflow.

To set the switching delay, proceed as follows:

1. Turn the function switch to position 5.
2. Press the "+" key for at least two seconds to select the next higher value. Hold the "+" or "-" keys down to skip from one value to another. The possible values are signaled by the LEDs 1 to 4.
3. Set the desired value.

You have now set the switching delay and can turn the function switch back to position 1 (operation).

6.2.10 Activating the self-test (function test)



Caution!

Make sure that you do not accidentally activate any processes with the self-test!
This could result, for example, in overflowing of the tank.

Function switch position	Function	- key	+ key	Light emitting diodes (LED signals)					
				⏻		⏻			⚙️
 A		 B	 C	 1 (green)	 2 (green)	 3 (red)	 4 (green)	 5 (green)	 6 (yellow)
6	Self-test (function test)	Press both keys		Off * (inactive)				Flashes (active)	**

* These settings are factory settings.

** Switch status signaling (on/off/flashing) depends on the mounting location selected and the failsafe mode (MIN/MAX) set.
The LED flashes if a calibration has not yet been carried out.



Note!

The self-test simulates switching states (probe not covered, probe covered).
This allows you to check if the connected devices are activated correctly.

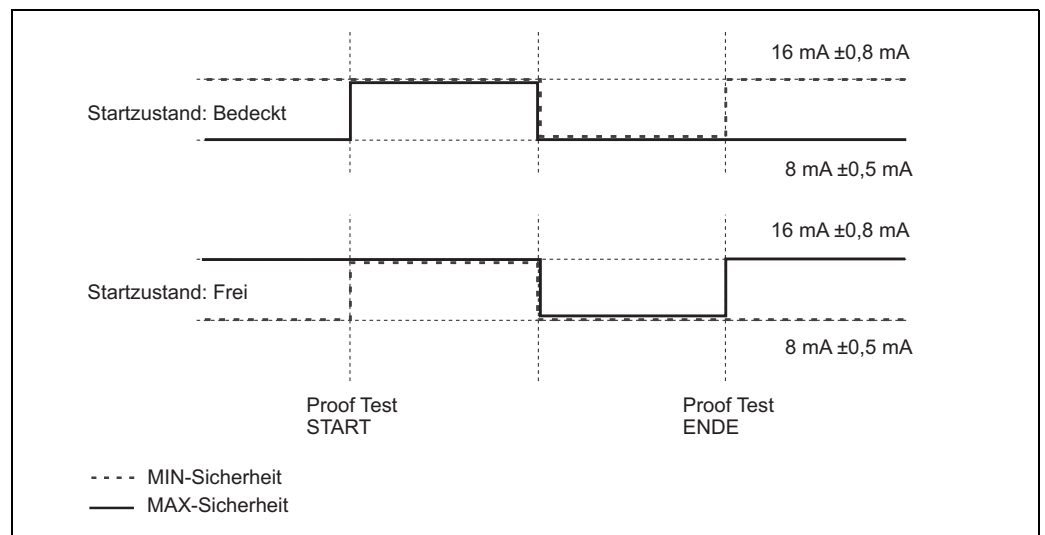

To carry out a self-test, proceed as follows:

1. Turn the function switch to position 6.
2. Press the "+" and "-" keys simultaneously for at least two seconds.
The self-test is active when the green LED 5 flashes.
The green operational LED 1 is off.
3. After approx. 20 seconds, the test is completed. This is indicated by the lighting up of the operational LED 1.

You have now carried out the self-test and can turn the function switch back to position 1 (operation).

6.2.11 Setting the MIN/MAX and SIL failsafe mode



Note!

The SIL mode function is only available in conjunction with electronic insert FEI55.

Function switch position	Function	- key	+ key	Light emitting diodes (LED signals)					
				1 (green)	2 (green)	3 (red)	4 (green)	5 (green)	6 (yellow)
1	Operation			Flashes Operational LED	On*** (MIN-SIL)	Flashes (warning/ alarm)	On*** (MAX-SIL)		On/off/ flashes**
7	MIN-/MAX Failsafe mode	Press for MIN	Press for MAX	Off (MIN)				On * (MAX)	**
	SIL mode*** lock/unlock	Press both keys			On (MIN-SIL)		On (MAX-SIL)		

* These settings are factory settings.

** Switch status signaling (on/off/flashing) depends on the mounting location selected and the failsafe mode (MIN/MAX) set. The LED flashes if a calibration has not yet been carried out.

*** The device is in the SIL mode. To change the current settings, the device must be unlocked.



Note!

By selecting the failsafe mode correctly, you ensure that the output always operates safely with quiescent current.

- **Minimum failsafe mode (MIN):** The output switches if the switch point is undershot (rod/rope uncovered), a fault occurs or the line voltage fails.
- **Maximum failsafe mode (MAX):** The output switches if the switch point is exceeded (rod/rope covered), a fault occurs or the line voltage fails.

To set the MIN or MAX failsafe mode, proceed as follows:

1. Turn the function switch to position 7.
2. Failsafe mode
 - Press the "-" key for at least two seconds to set the MIN failsafe mode. The green LED 1 starts to light up.
 - Press the "+" key for at least two seconds to set the MAX failsafe mode. The green LED 5 starts to light up.

You have now set the failsafe mode and can turn the function switch back to position 1 to resume operation.

Locking the SIL mode

You can use the "SIL mode" to protect the device settings from being changed accidentally. The device settings can only be changed once the "SIL mode" has been unlocked.

- Turn the function switch to position 7 "locking/unlocking the SIL mode".
- Check the MIN or MAX failsafe mode selected.
- To unlock the selected failsafe mode, proceed as follows:
 - Press the "-" and "+" keys simultaneously for approx. 4 seconds and
 - release the keys when the red LED (fault message) starts to flash.



Note!

















Locking in the "Lock SIL mode" activates the fault message at the current output ($I < 3.6$ mA). This is signaled by the red LED 3 lighting up.

- Active locking is indicated as follows:
 - With "MIN-SIL", active locking is indicated by the green LED 2 lighting up. The LED 1 that is lit goes out.
 - With "MAX-SIL", active locking is indicated by the green LED 4 lighting up. The LED 5 that is lit goes out.
- The set SIL mode is activated by setting the function switch to position 1 "operation". The red LED 3 goes out and the green LED 1 starts flashing.
The device is ready for operation!

Unlocking the SIL mode

- Turn the function switch to position 7 "locking/unlocking the SIL mode".
- To unlock the device, proceed as follows:
 - Press the "-" and "+" keys simultaneously for approx. 4 seconds and
 - release the keys when the "MIN-SIL" or "MAX-SIL" LED goes out.
- Turn the function switch to position 1 "operation" to operate the device without the SIL mode.

6.2.12 Upload/download sensor DAT (EEPROM)

Function switch position	Function	- key	+ key	Light emitting diodes (LED signals)					
									
 A									
8 	Upload/download sensor DAT (EEPROM)	Press for download	Press for upload	Flashes (download)				Flashes (upload)	**

** Switch status signaling (on/off/flashing) depends on the mounting location selected and the failsafe mode (MIN/MAX) set. The LED flashes if a calibration has not yet been carried out.



Note!

- The customer-specific settings of the electronic insert (e.g. empty/full calibration, switch point adjustment) are stored automatically in the sensor DAT (EEPROM) and in the electronic insert.
- The sensor DAT (EEPROM) is updated automatically each time a parameter is changed in the electronic insert.
- When replacing the electronic insert, all the sensor DAT (EEPROM) data are transferred to the electronic insert by means of a manual upload. No additional settings are required.
- If, for example, you need to transfer the customer-specific settings of an electronic insert to multiple sensor DATs (EEPROMs), you must carry out a manual download after installing the electronic insert.







- **Upload:** An upload transfers the saved data from the sensor DAT (EEPROM) to the electronic insert. The electronic insert does not have to be configured any more, and the device is then operational.
- **Download:** A download transfers the saved data from the electronic insert to the sensor DAT (EEPROM).

To carry out a sensor upload/download, proceed as follows:

1. Turn the function switch to position 8.
2. Press the "-" key for at least two seconds to carry out a download (the data from the electronic insert are transferred to the sensor DAT (EEPROM). During the download, the green LED 1 flashes.
3. Press the "+" for at least two seconds to carry out an upload (the data from the sensor DAT (EEPROM) are transferred to the electronic insert). The green LED 5 flashes during upload.

You have now transmitted the data and can turn the function switch back to position 1 (operation).

6.2.13 Restoring factory settings

Function switch position	Function	- key	+ key	Light emitting diodes (LED signals)					
									
A		B	C	1 (green)	2 (green)	3 (red)	4 (green)	5 (green)	6 (yellow)
1 	Operation			Flashes Operational LED	On*** (MIN-SIL)	Flashes (warning/ alarm)	On*** (MAX-SIL)		On/off/ flashes**
	Restore factory setting	Press both keys for approx. 20 s		On	->	->	->	->	**

** Switch status signaling (on/off/flashing) depends on the mounting location selected and the failsafe mode (MIN/MAX) set. The LED flashes if a calibration has not yet been carried out.

*** Only in conjunction with electronic insert FEI55 (SIL). The device is in the SIL mode. To change the current settings, the device must be unlocked.



Note!

- This function allows you to restore the factory settings. This is particularly useful if the device has already been calibrated once and, for example, there is a fundamental change in the medium in the tank.
- After restoring the factory settings, you must repeat the calibration.

To restore the factory settings, proceed as follows:

1. Turn the function switch to position 1.
2. Press the "+" and "-" keys simultaneously for approx. 20 seconds. During the time it takes to restore the factory settings, the LEDs 1–5 light up consecutively.
3. The factory settings have been successfully restored if the green LED 1 and the yellow LED are flashing.

You have now restored the factory settings and can continue with setting the measuring range and the calibration.

6.2.14 Output signals

Output signal FEI51

Safety mode	Level	Output signal	LEDs					
			gn	gn	rd	gn	gn	ye
MAX		L^+ 1 $\xrightarrow{I_L}$ 3						
		$1 \xrightarrow{< 3,8 \text{ mA}} 3$						
MIN		L^+ 1 $\xrightarrow{I_L}$ 3						
		$1 \xrightarrow{< 3,8 \text{ mA}} 3$						
Maintenance required		$I_L / < 3,8 \text{ mA}$ 1 $\xrightarrow{\quad} 3$						
Instrument failure		$< 3,8 \text{ mA}$ 1 $\xrightarrow{\quad} 3$						

BA300Fen017

* See → 71, "Troubleshooting"

Output signal FEI52

Safety mode	Level	Output signal	LEDs					
			gn	gn	rd	gn	gn	ye
MAX		L^+ 1 $\xrightarrow{I_L}$ 3						
		$1 \xrightarrow{I_R} 3$						
MIN		L^+ 1 $\xrightarrow{I_L}$ 3						
		$1 \xrightarrow{I_R} 3$						
Maintenance required		I_L / I_R 1 $\xrightarrow{\quad} 3$						
Instrument failure		I_R 1 $\xrightarrow{\quad} 3$						

TI418Fen43

* See → 71, "Troubleshooting"

Output signal FEI54

Safety mode	Level	Output signal	LEDs					
			gn	gn	rd	gn	gn	ye
MAX								
MIN								
Maintenance required								
Instrument failure								

* See → 71, "Troubleshooting"

T1418Fen48

Output signal FEI55

Safety mode	Level	Output signal	LEDs					
			gn	gn	rd	gn	gn	ye
MAX		$\begin{matrix} + \\ 2 \end{matrix} \xrightarrow{\sim 16 \text{ mA}} 1$						
		$\begin{matrix} + \\ 2 \end{matrix} \xrightarrow{\sim 8 \text{ mA}} 1$						
MIN		$\begin{matrix} + \\ 2 \end{matrix} \xrightarrow{\sim 16 \text{ mA}} 1$						
		$\begin{matrix} + \\ 2 \end{matrix} \xrightarrow{\sim 8 \text{ mA}} 1$						
Maintenance required *		$\begin{matrix} + \\ 2 \end{matrix} \xrightarrow{8/16 \text{ mA}} 1$						
Instrument failure		$\begin{matrix} + \\ 2 \end{matrix} \xrightarrow{< 3.6 \text{ mA}} 1$						

* See → 71, "Troubleshooting"

T1418Fen51

6.3 Commissioning with electronic inserts FEI53 or FEI57S

This chapter describes the process for commissioning the device with electronic insert versions FEI53 and FEI57S.



Note!

The measuring system is not operational until you have carried out a calibration at the switching unit.

For information on how to carry out the calibration, refer to the documentation for the Nivotester switching device: FTC325 3-Wire, FTC325 PFM, FTC625, FTC325, FTC470Z or FTC471Z

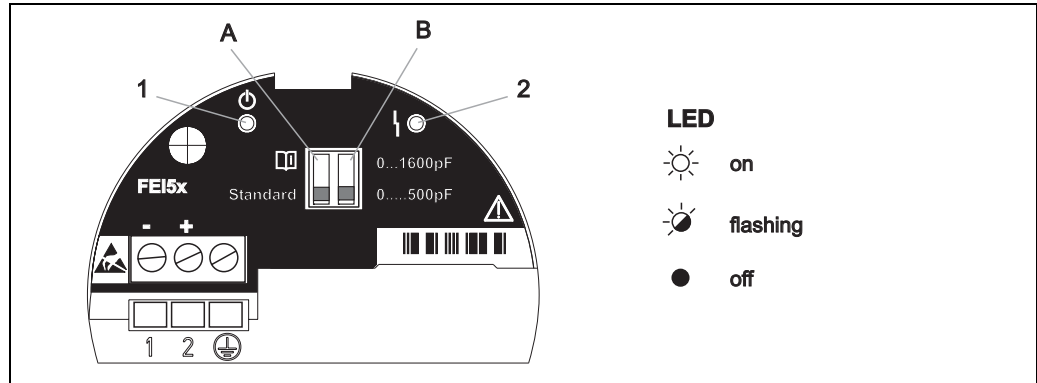

LED 1 operational ⏻: Flashes at 5-second intervals.

LED 2 fault ⚡: The red LED flashes if there is a fault that you can correct.

LED 2 fault ⚡: The red LED lights up continuously if the device has a fault that cannot be corrected. See also Seite 71, "Troubleshooting".

6.3.1 Setting the alarm response if the measuring range is exceeded



DIP switch	Function
A Standard	Standard: If the measuring range is exceeded no alarm is output (factory setting).
A	: If the measuring range is exceeded an alarm is output.



Note!

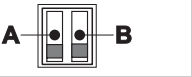

- With this setting, you can determine the alarm response of the measuring system If the measuring range is exceeded. You can switch the alarm on or off If the measuring range is exceeded.
- All other settings with regard to the alarm response have to be configured on the respective Nivotester switching device.

6.3.2 Setting the measuring range

DIP switch		Function
		
B		Measuring range: The measuring range is between 0 and 500 pF Span: The span is between 5 and 500 pF.
B		Measuring range: The measuring range is between 0 and 1600 pF Span: The span is between 5 and 1600 pF.











Note!

- The choice of measuring range (0 to 500 pF and 0 to 1600 pF) depends on the function of the probe. If the probe is used as a point level switch, you can retain the factory setting of 0 to 500 pF.
- If the probe is used for two-point control, the following recommendations apply for vertical installation:
 - Measuring range from 0 to 500 pF for probe lengths up to 1.0 m
 - Measuring range from 0 to 1600 pF for probe lengths up to 4.0 m
 - (See also →  3.4 on →  16)

All other settings must be made on the respective Nivotester switching device.

6.3.3 Output signals

Output signal FEI53

Mode	Output signal	LEDs	
		green	red
Normal operation	3...12 V at terminal 3		
Maintenance required * 	3...12 V at terminal 3		
Instrument failure 	< 2,7 V at terminal 3		

* See →  71, "Troubleshooting"

TI418Fen46

Output signal FEI57S

Mode	Output signal	LEDs	
		green	red
Normal operation	60...185 Hz 1 -----> 2		
Maintenance required * 	60...185 Hz 1 -----> 2		
Instrument failure 	< 20 Hz 1 -----> 2		

TI18Fen54

* See → 71 ff., "Troubleshooting"

6.4 Commissioning with the electronic insert FEI58

This chapter describes the process for commissioning the device with electronic insert FEI58.



Note!

- The measuring system is not operational until you have carried out a calibration.
- Additional functions associated with the switching unit are described in the documentation for the switching unit, e.g. Nivotester FTL325N, FTL375N (for devices from Endress+Hauser).

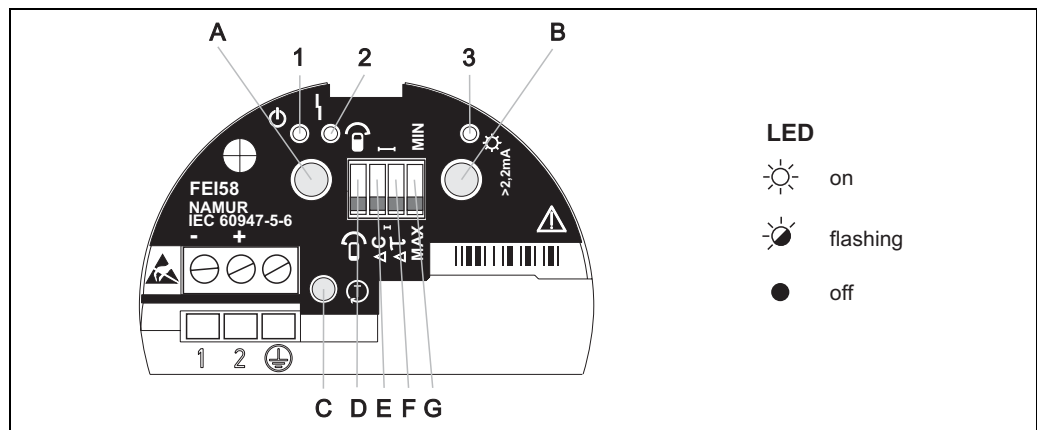

BA299Fen016

Green LED 1 (🟢 ready for operation), red LED 2 (🔴 error indicated), yellow LED 3 (🟡 switching state)

6.4.1 Keys (A, B, C) on FEI58

- To prevent unintentional operation of the device, approx. 2 seconds (s) have to elapse before the system evaluates and executes a function commanded when a key is pressed (keys A and B). Test key C disconnects the power supply immediately.
- Both keys have to be pressed simultaneously to trigger switch point adjustment.



Key			Function
A	B	C	
X			Display diagnostic code
	X		Display calibration situation
X	X		Perform calibration (during operation)
X	X		Delete calibration points (during startup)
		X	Test key 🟢, (disconnects the transmitter from the switching unit)

6.4.2 Performing calibration

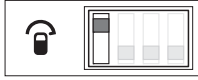

Note!

- An empty and full calibration provides the greatest possible operational security. This is particularly recommended for critical applications.
- The empty and full calibration measures the capacitance values of the probes when the tank is full and when it is empty. If, for example, the measured capacitance value of the empty calibration is 50 pF and that of the full calibration is 100 pF, the average capacitance value, 75 pF, is stored as the switch point.

DIP switch: C		Function
D		The probe is covered during calibration.
D		The probe is uncovered during calibration.

Carrying out empty calibration

To carry out an empty calibration, proceed as follows:

1. Check to make sure that the probe is not covered with product.
2. Before calibrating, select the "uncovered" probe state on DIP switch D.
3. Press keys **A** and **B** simultaneously for at least 2 s to save the calibration value.
4. The green LED 1 flashes quickly to indicate that the value has been saved correctly.

The process of saving the empty calibration value is finished once green LED 1 flashes slowly again.

Carrying out full calibration

To carry out a full calibration, proceed as follows:



1. Make sure that the probe is covered by the medium up to the desired switch point.
2. Before calibrating, select the "covered" probe state on DIP switch D.
3. Press keys **A** and **B** simultaneously for at least 2 s to save the calibration value.
4. The green LED 1 flashes quickly to indicate that the value has been saved correctly.

The process of saving the empty calibration value is finished once green LED 1 flashes slowly again.

6.4.3 Setting the switch point adjustment

Note the following when selecting switch point adjustment:

- If only one calibration (empty or full) was carried out, and if buildup forms on the rod probe while the probe is in operation, the device may no longer respond to changes in level. A switch point adjustment compensates for this condition and ensures that you obtain a constant switch point again.
- For media that do not have a tendency to build up, we recommend a setting of 2 pF, as the probe is most sensitive to changes in level at this setting.
- For media with heavy buildup (e.g. plaster), we recommend using probes with active buildup compensation and using the setting 10 pF.

DIP switch: D		Function
E		Switch point adjustment: 10 pF (for media with heavy buildup, e.g. sewage sludge)
E		Switchpoint adjustment: 2 pF (for media that do not cause buildup e.g. water)

6.4.4 Setting the switching delay





Note!

- The switching delay causes the device to signal the point level after a delay. This is particularly useful in tanks with turbulent medium surfaces caused, for example, by the filling process or by collapsing mounds. By doing so, you ensure that the filling of the tank does not end until the probe is continuously covered by the medium.
- A switching delay that is too short may, for example, cause the filling process to be restarted as soon as the medium surface settles.



Caution!

If too long of a switching delay is set, this can cause the tank to overflow.

DIP switch: E		Function
F		Switching delay: 5 s
F		Switching delay: 1 s



6.4.5 MIN/MAX failsafe mode



Note!

By selecting the failsafe mode correctly, you ensure that the output always operates safely with quiescent current.

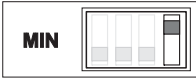
- **Minimum failsafe mode (MIN):** The output switches if the switch point is undershot (rod/rope uncovered), a fault occurs or the line voltage fails.
- **Maximum failsafe mode (MAX):** The output switches if the switch point is exceeded (rod/rope covered), a fault occurs or the line voltage fails.

DIPswitch: F		Function
G		Fail-safe mode: MIN The output switches safety-oriented when the probe is uncovered (signal on alarm). For use for dry running protection and pump protection for example
G		Fail-safe mode: MAX The output switches safety-oriented when the probe is covered (signal on alarm). For use with overflow protection for example

6.4.6 Display calibration situation

You can use this function to see what calibrations have been performed on the device. The calibration situation is indicated by the three LEDs.

To query the calibration situation, proceed as follows:

1. Press the **B** key for at least 2 s.
2. The current calibration situation is indicated by the LEDs (operating/switching status).

Light emitting diodes (LED signals)			Calibration situation
Green LED 1 ⏻ Operational	Red LED 2 ⚠ Fault	Yellow LED 3 ⚙ Switching status	
			No calibration
On			Empty calibration performed
		On	Full calibration performed
On		On	Empty and full calibration performed

6.4.7 Displaying the diagnostic code

This function makes it possible to interpret faults using the three LEDs. If the system detects more than one fault, the fault with the highest priority is shown on the display.

Further information is provided in the "Fault diagnostics" section → [72](#).

6.4.8 Test key C (open circuit)



Caution!

This test can be used to activate safety-specific measures in the plant (e.g. alarms)!

Pressing test key C disconnects the supply voltage.

If the power supply is disconnected, a supply unit such as Nivotester FTL325N from Endress+Hauser reacts in such a way that the alarm relay outputs an error and appropriate responses are triggered in any slave devices connected.

To perform the function test, proceed as follows:

1. Press test key C for the entire duration of the test.
The power supply from the supply unit is disconnected immediately.
2. All the LEDs go out. The safety functions (e.g. error message alarm) configured for the supply unit are activated.
3. Release test key C again to end the function test.

6.4.9 Output signals

Output signal FEI58

Safety mode	Level	Output signal	LEDs		
			gn	rd	ye
MAX		+ 2.2 ... 3.5 mA 2 → 1			
		+ 0.6 ... 1.0 mA 2 → 1			
MIN		+ 2.2 ... 3.5 mA 2 → 1			
		+ 2 → 1			
Maintenance required *		+ 0.6 ... 1.0 mA 2 → 1 2.2 ... 3.5 mA			
Instrument failure		+ 0.6 ... 1.0 mA 2 → 1			

* See also → 71 ff., "Troubleshooting"

TI418Fen54

7 Maintenance

No special maintenance work is required on the Liquicap M point level switch.

Exterior cleaning

When cleaning the exterior of the Liquicap M, always use cleaning agents that do not attack the surface of the housing or the seals.

Cleaning the probe

Depending on the application, buildup (contamination and soiling) can form on the probe rod. A high degree of material buildup can affect the measurement result. If the medium tends to create a high degree of buildup, regular cleaning is recommended. When cleaning, it is important to make sure that the insulation of the probe rod is not damaged. If cleaning agents are used make sure the material is resistant to them!

Seals

The process seals of the sensor should be replaced periodically, especially when using molded seals (aseptic version)! The period between changes depends on the frequency of cleaning cycles, the cleaning temperature and the medium temperature.

Repair

In accordance with the Endress+Hauser repair principle, the devices have a modular design and repairs can be carried out by the customer.

Spare parts are grouped logically into kits along with the respective replacement instructions. The "Spare parts" section lists all spare part kits, with their order numbers, that you can order from Endress+Hauser for repair of the Liquicap M. For more information about service and spare parts, contact Endress+Hauser Service.

Repairing Ex-certified devices

The following information also has to be taken into account for repairs of Ex-certified devices:

- Ex-certified devices may be repaired only by experienced, skilled staff or by Endress+Hauser Service.
- Applicable standards, federal/national Ex standards and the Safety Instructions (XA) and certificates must be observed.
- Only genuine spare parts from Endress+Hauser may be used.
- When ordering spare parts, please note the device designation on the nameplate. Parts can only be replaced by the same parts.
- Repairs must be carried out according to the instructions. Following the repair, the individual testing specified for the device must be carried out.
- Certified devices can only be converted into other certified devices by Endress+Hauser Service.
- Every conversion and repair made to the device must be documented.

Replacement

After replacing a Liquicap M or the electronic insert, the calibration values must be transferred to the replacement device.

→ When the probe is replaced, the calibration values in the electronic insert are transferred to the sensor DAT (EEPROM) module via a manual download.

→ If the electronic insert is replaced, the calibration values of the sensor DAT (EEPROM) are transferred to the electronics by means of a manual upload.

You can put the device back into operation without recalibrating it. (For more information, refer to Section 6.2.10, Sensor DAT (EEPROM) upload/download.)

8 Accessories

8.1 Protective cover

For F13, F17 and F27 housing (without display)
Order number: 71040497

For F16 housing
Order number: 71127760

8.2 Shortening kit for FTI52

Order number: 942901-0001

8.3 Overvoltage protection HAW56x

Surge arrester for limiting overvoltage in signal lines and components: see Technical Information TI417F →  80.

8.4 Weld-in adapter

All the weld-in adapters available are described in the document TI426F.
www.endress.com → Country → Download → Advanced → Documentation code → TI426F.

9 Troubleshooting

9.1 Fault diagnostics in the electronic insert



Note!

In the event of faults during commissioning or operation of the device, you have the ability to carry out fault diagnostics on the electronic insert. This function is supported by the electronic inserts FEI51, FEI52, FEI54, FEI55 (see error table 1 and 2 below).

The electronic inserts FEI53, FEI57S and FEI58 signal two types of faults:

- Faults that can be rectified: The red LED flashes.
- Faults that cannot be rectified: The red LED is lit continuously.

For additional information on fault detection and fault elimination, refer to fault table 2 below.

9.1.1 Activating fault diagnostics FEI51, FEI52, FEI54, FEI55



Note!

The diagnostics provide information about the operating status of the device. The results of the diagnostics are displayed by LEDs 1, 2, 4 and 5. If the diagnostics detect multiple faults, these are shown according to their priority. A serious fault (e.g. priority 3) is always displayed before a less serious fault (e.g. priority 5).

To activate the fault diagnostics, proceed as follows:

1. Set the function switch to position 1 (operation).
2. Press the "-" key.
3. "Fault table 1" lists possible causes of faults and information on how to eliminate them.

LEDs for diagnostics						Error table 1 (FEI51, FEI52, FEI54, FEI55) Cause	Remedy	Priority
1 (green)	2 (green)	3 (red)	4 (green)	5 (green)	6 (yellow)			
						No fault		
On						Internal fault	Replace the electronics	1
	On				On	Calibration point(s) are outside the measuring range	Recalibrate	2
On				On		Calibration points have been accidentally interchanged	Recalibrate	3
	On					The calibration point is too close to the measuring range limit	Reduce the switch point or select a new installation location	4
On	On					No calibration has yet been carried out	Carry out empty and/or full calibration	5
			On			The DC PNP output is overloaded*	Reduce the connected load	6
On			On			The capacitance change from "Probe not covered" to "Probe covered" is too small	Contact Endress+Hauser Service	7
	On		On			Sensor DAT (EEPROM) data are invalid	Carry out download from the electronic insert	8
On	On		On			Probe is not detected**	The probe type is not compatible. Use a Solicap S probe.	9
				On		The measured temperature is outside the permitted temperature range	Operate the device in the specified temperature range only	10

* Applies only to electronic insert FEI52.

** A connection to the sensor DAT (EEPROM) could not be established.

9.1.2 Fault diagnostics FEI53, FEI57S

Cause	Remedy
The device does not switch.	Check the connection and the supply voltage.
Alarm LED flashes.	The ambient temperature of the electronics is outside the permitted range or the connection to the probe is interrupted.

9.1.3 Activating fault diagnostics FEI58

Displaying the diagnostic code

This function makes it possible to interpret faults using the three LEDs. If the system has detected more than one fault, the fault with the highest priority is shown on the display.

To display the diagnostic code, proceed as follows:

1. Press the B key for at least 2 s.
2. The current diagnostics code is indicated by the LEDs (operating/fault/switching status).

No.	1 green operational	2 red fault	3 yellow switching status	Cause	Remedy	Priority
0				No fault	---	---
1	On			Internal fault	The device is defective	1
2		On		The calibration point is too close to the measuring range limit	Reduce the switch point or select a new installation location	2
3			On	Calibration points have been accidentally interchanged	Perform uncovered calibration with the probe uncovered, and covered calibration with the probe covered	3
4	On	On		No calibration has yet been carried out	Carry out empty and/or full calibration	4
5	On		On	The change in capacitance from uncovered probe to covered probe is too small	The capacitance change between the uncovered and covered probe must be greater than 2 pF	5
6		On	On	Probe not detected	Connect the probe	6
7	On	On	On	The measured temperature is outside the permitted range	The device may be operated in the specified temperature range only	7

9.2 Spare Parts

An overview of the spare parts for your device is available in the internet at www.endress.com. To obtain information on the spare parts, proceed as follows:

1. Go to "www.endress.com" and select your country.
2. Click "Instruments".

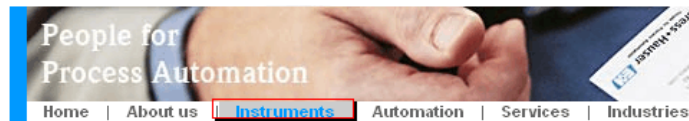

3. Enter the product name into the "product name" field.

Endress+Hauser product search

Via product name

Enter the product name

4. Select the device.

- Click the "Accessories/Spare parts" tab.

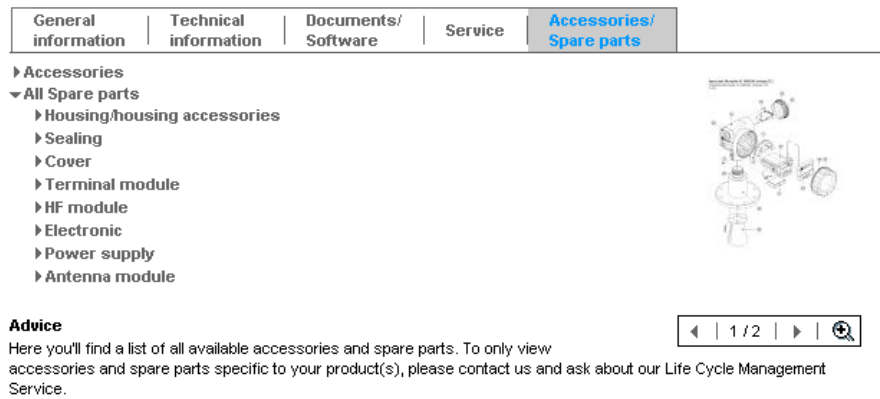

- Select the required spare parts (You may also use the overview drawing on the right side of the screen.)

When ordering spare parts, always quote the serial number indicated on the nameplate. As far as necessary, the spare parts also include replacement instructions.

9.3 Return

You must take the following measures before returning a measuring device to Endress+Hauser, for example for repair:

- Remove all traces of the medium. Pay particular attention to crevices and grooves for seals into which the medium can penetrate. This is particularly important if the medium is hazardous to health, e.g. combustible, toxic, caustic, carcinogenic etc.
- Always enclose a fully completed "Declaration of contamination" form with the device (a master copy of the "Declaration of contamination" form can be found at the end of these Operating Instructions). Only then can Endress+Hauser check or repair a returned device.
- If necessary, enclose special handling instructions when returning the device, e.g. a safety data sheet in accordance with EN 91/155/EEC.

In addition, specify the following:

- The chemical and physical properties of the medium
- A description of the application
- A description of the fault that occurred
- Operating time of the device

9.4 Disposal

At disposal, ensure that materials are properly separated and the device components are reused.

9.5 Firmware history

Electronics	Release date	Software version	Software change
FEI51	10/2007	V 01.00.XX	Original software
FEI52	07/2006	V 01.00.XX	Original software
FEI53	07/2006	V 01.00.XX	Original software
FEI54	07/2006	V 01.00.XX	Original software
FEI55	11/2008	V 02.00.XX	Extended to include SIL functionality
FEI57s	07/2006	V 01.00.XX	Original software
FEI58	01/2010	V 01.00.XX	Original software

9.6 Contact addresses at Endress+Hauser

On the back page of these Operating Instructions, you can find an internet address for Endress+Hauser. The web site provides contact addresses that you can use in case of any questions.

10 Technical data

10.1 Capacitance values of the probe

Basic capacitance: approx. 18 pF

Additional capacitance

Mount the probe at a minimum distance of 50 mm from a conductive container wall:

- Probe rod: approx. 1.3 pF/100 mm in air
- Probe rope: approx. 1.0 pF/100 mm in air

Fully insulated probe rod in water:

- Approx. 38 pF/100 mm (16 mm rod)
- Approx. 74 pF/100 mm (14 mm rod)
- Approx. 45 pF/100 mm (10 mm rod)
- Approx. 50 pF/100 mm (22 mm rod)

Insulated probe rope in water: approx. 19 pF/100 mm

Rod probe with ground tube:

- Insulated probe rod: approx. 6.4 pF/100 mm in air
- Insulated probe rod: approx. 38 pF/100 mm in water (16 mm rod)
- Insulated probe rod: approx. 45 pF/100 mm in water (10 mm rod)

10.2 Input

10.2.1 Measuring range

- Measuring frequency:
500 kHz
- Span:
 $\Delta C = 5$ to 1600 pF
 $\Delta C = 5$ to 500 pF (with FEI58)
- Final capacitance:
 $C_E = \text{max. } 1600$ pF
- Adjustable initial capacitance:
 $C_A = 5$ to 500 pF (range 1 = factory setting)
 $C_A = 5$ to 1600 pF (range 2; not with FEI58)
- The minimum change in capacitance for point level detection must be ≥ 5 pF.

Minimum probe length for nonconductive media ($< 1 \mu\text{s/cm}$)

$$l_{\min} = \Delta C_{\min} / (C_s * [\epsilon_r - 1])$$

$$l_{\min} = \text{Minimum probe length (m)}$$

$$\Delta C_{\min} = 5 \text{ pF}$$

$$C_s = \text{Probe capacitance in air} \rightarrow \text{Fig. 74 "Capacitance values of the probe"}$$

$$\epsilon_r = \text{Dielectric constant e.g. oil} = 2.0$$

10.3 Output

10.3.1 Switch behavior

Binary or Δs operation (pump control, not with FEI58)

10.3.2 Switch-on behavior

When the power supply is switched on, the switching status of the outputs corresponds to the signal on alarm.

The correct switch condition is reached after max. 3 seconds.

10.3.3 Failsafe mode

Minimum/maximum quiescent current safety can be switched at the electronic insert (for FEI53 and FEI57S only on the associated Nivotester: FTC325 3-Wire, FTC325 PFM and FTC625)

MIN = minimum safety: The output switches safety-oriented when the probe is uncovered (signal on alarm). For use for dry running protection and pump protection for example

MAX = maximum safety: The output switches safety-oriented when the probe is covered (signal on alarm). For use with overflow protection for example

10.3.4 Galvanic isolation

FEI51, FEI52

between rod probe and power supply

FEI54:

between rod probe, power supply and load

FEI53, FEI55, FEI57S, FEI58

see connected switching device (functional galvanic isolation in the electronic insert)

10.4 Performance characteristics

Uncertainty: DIN 61298-2: max $\pm 0.3\%$

Non-repeatability (reproducibility): DIN 61298-2: max. $\pm 0.1\%$

10.4.1 Ambient temperature effect

Electronic insert

$< 0.06\%$ / 10 K related to the full scale value

Separate housing

Capacitance change of connecting cable per meter 0.15 pF/10K

10.5 Operating conditions: Environment

10.5.1 Ambient temperature range

- -50 to $+70$ °C
- -40 to $+70$ °C (with F16 housing)
- Observe derating → [76](#)
- If operating outdoors, use a protective cover! → [70](#).

10.5.2 Storage temperature

-50 to $+85$ °C

10.5.3 Climate class

DIN EN 60068-2-38/IEC 68-2-38: test Z/AD

10.5.4 Vibration resistance

DIN EN 60068-2-64/IEC 68-2-64: 20 Hz– 2000 Hz; 0.01 g²/Hz

10.5.5 Shock resistance

DIN EN 60068-2-27/IEC 68-2-27: 30g acceleration

10.5.6 Degree of protection

	IP66*	IP67*	IP68*	NEMA4X*
Polyester housing F16	X	X	–	X
Stainless steel housing F15	X	X	–	X
Aluminum housing F17	X	X	–	X
Aluminum housing F13 with gas-tight process seal	X	–	X***	X
Stainless steel housing F27	X	X	X***	X
Aluminum housing T13 with gas-tight process seal and separate connection compartment (EEx d)	X	–	X***	X
Separate housing	X	–	X***	X

* As per EN60529

** As per NEMA 250

*** Only with M20 cable entry or G1/2 thread

10.5.7 Electromagnetic compatibility (EMC)

- Interference emission to EN 61326, Electrical Equipment Class B
Interference immunity in accordance with EN 61326, Appendix A (Industrial) and NAMUR Recommendation NE 21 (EMC)
- A usual commercial instrument cable can be used.

10.6 Operating conditions: Process

10.6.1 Process temperature range

The following diagrams apply for:

- Rod and rope version
- Insulation: PTFE, PFA, FEP
- Standard applications outside hazardous areas



Note!

The temperature is restricted to T_a –40 °C if the polyester housing F16 is used or if additional option B is selected (free from paint-wetting impairment substances, only FTI51).

With compact housing

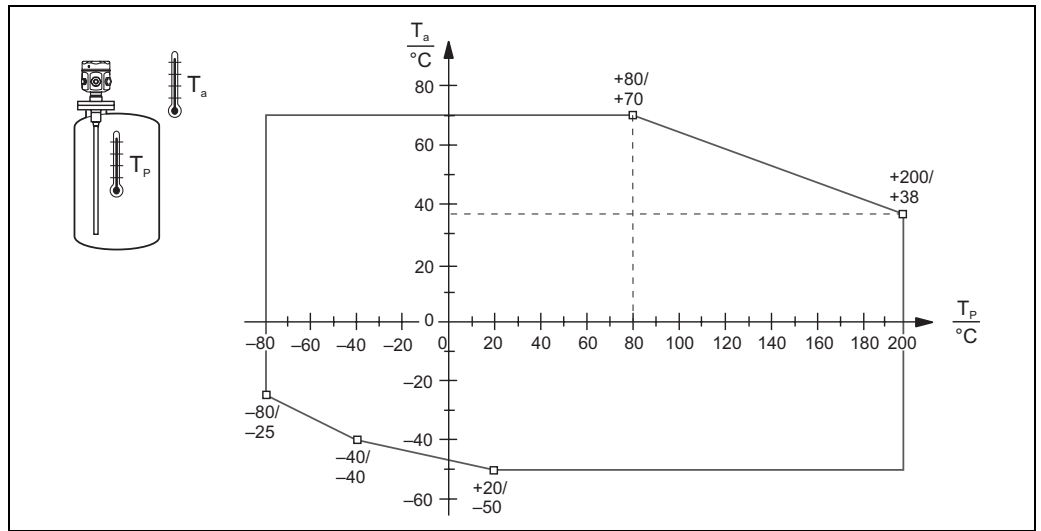

L00-FMI5xxxx-05-05-xx-xxx-013

*T_a: Ambient temperature
T_P: Process temperature*

With separate housing

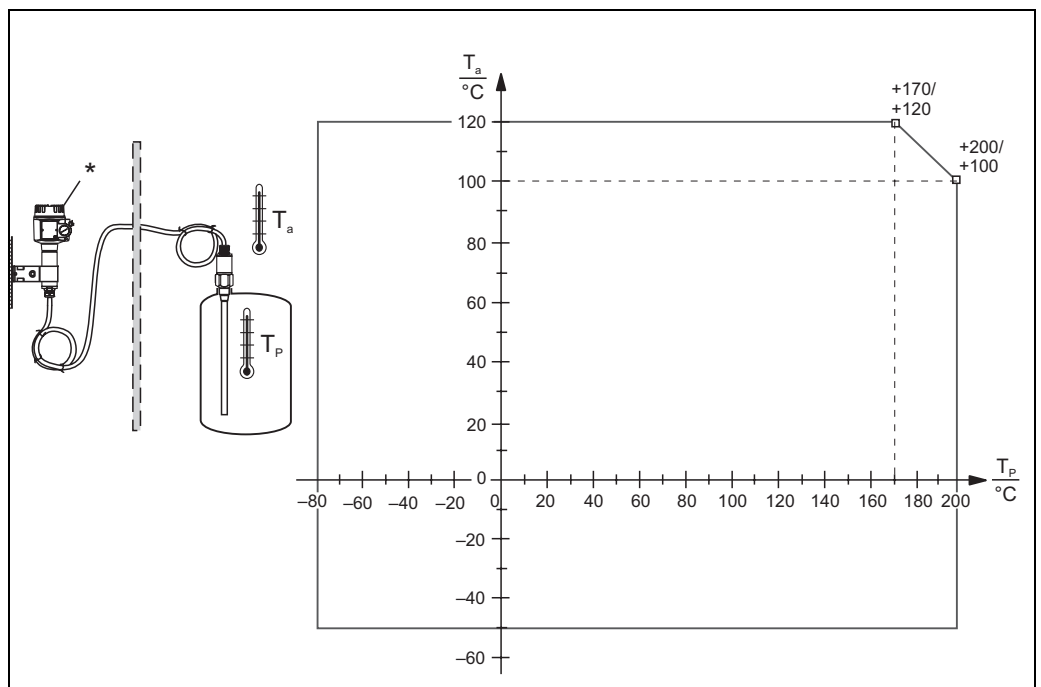

L00-FMI5xxxx-05-05-xx-xxx-011

*T_a = Ambient temperature
T_P = Process temperature
* Observe the permitted ambient temperature at the separate housing.*

10.6.2 Process pressure limits

Probe ø10 mm, ø14 mm (including insulation)

-1 to 25 bar

Probe ø16 mm (including insulation)

- -1 to 100 bar
- In the event of an inactive length, the maximum permitted process pressure is 63 bar
- In the event of CRN approval and inactive length, the maximum permitted process pressure is 32 bar.

Probe ø22 mm (including insulation)

-1 to 50 bar

Refer to the following standards for the pressure values permitted at higher temperatures:

- EN 1092-1: 2005 Table, Appendix G2
With regard to its resistance/temperature property, the material 1.4435 is identical to 1.4404 (AISI 316L) which is grouped under 13E0 in EN 1092-1 Tab. 18. The chemical makeup of the two materials can be identical.
- ASME B 16.5a- 1998 Tab. 2-2.2 F316
- ASME B 16.5a- 1998 Tab. 2.3.8 N10276
- JIS B 2220

The lowest value from the derating curves of the device and the selected flange applies.

10.6.3 Pressure and temperature derating

For process connections ½", ¾", 1", flanges < DN50, < ANSI 2", < JIS 10K (10 and 14 mm rod) as well as process connections ¾", 1", flanges < DN50, < ANSI 2", < JIS 10K (16 mm rod)

Rod insulation: PTFE

Rope insulation: FEP, PFA

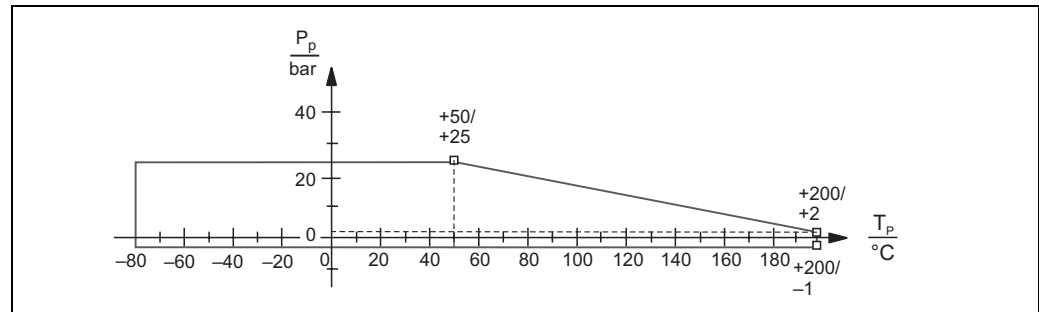

Pp : Process pressure

Tp : Process temperature

For process connections 1½", flanges ≥ DN50, ≥ ANSI 2", ≥ JIS 10K (16 mm rod)

Rod insulation: PTFE, PFA

Rope insulation: FEP, PFA

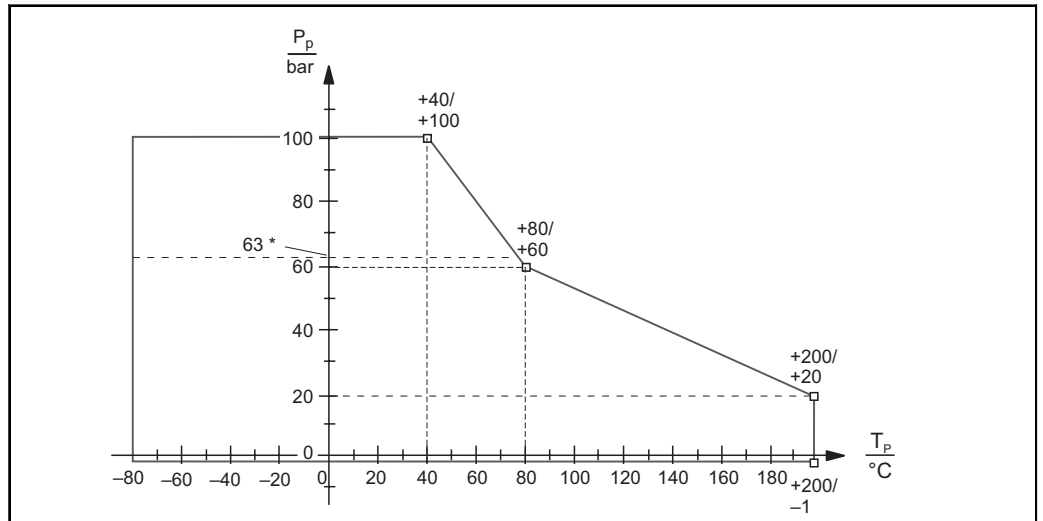

P_p : Process pressure
 T_p : Process temperature

With a fully insulated inactive length (22 mm rod):

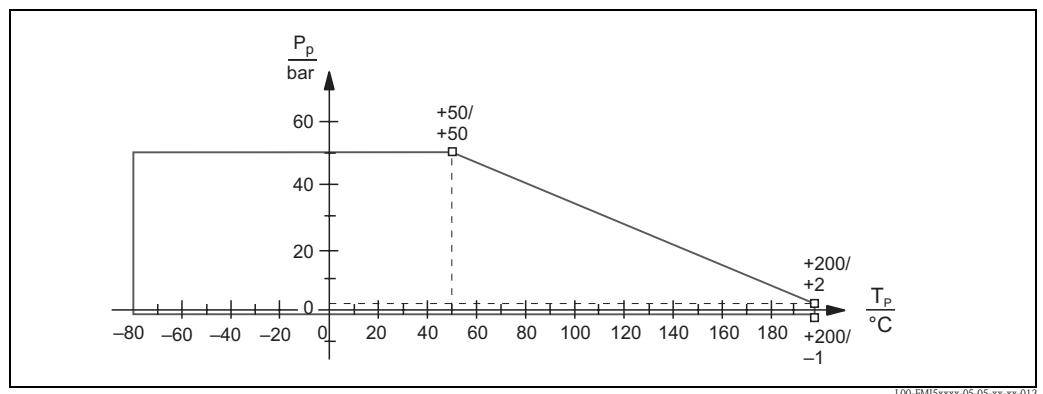

P_p : Process pressure
 T_p : Process temperature

10.7 Other standards and guidelines

EN 60529

Degrees of protection by housing (IP code)

EN 61010

Safety requirements for electrical equipment for measurement, control and laboratory use

EN 61326

Interference emission (Class B equipment), interference immunity (Appendix A – Industrial).

NAMUR

Association for Standards for Control and Regulation in the Chemical Industry

IEC 61508

Functional safety

IEC 60947-5-6

Low-voltage switchgear and control gear; DC interface for proximity sensors and switching amplifiers (NAMUR)

10.8 Documentation



Note!

This documentation is available on the product pages at www.endress.com.

10.8.1 Technical Information

- Nivotester FTL325N
TI00353F/00/en
- Nivotester FTL375N
TI00361F/00/en
- Liquicap M FTI51, FTI52
TI00417F/00/en
- EMC test procedures
TI00241F/00/en

10.8.2 Certificates

ATEX safety instructions

- Liquicap M FTI51, FTI52
ATEX II 1/2 G EEx ia IIC/IIB T3 to T6, II 1/2 D IP65 T 85 °C
XA00327F/00/a3
- Liquicap M FTI51, FTI52
ATEX II 1/2 G EEx d [ia] IIC/IIB T3 to T6
XA00328F/00/a3

NEPSI safety instructions

- Liquicap M FTI51, FTI52
Ex ia IIC/IIB T3 to T6
XA00417F/00/a3
- Liquicap M FTI51, FTI52
EEx de [ia] IIC/IIB T3 to T6
XA00418F/00/a3

Overfill protection DIBt (WHG)

- Liquicap M FTI51, FTI52
ZE00268F/00/en

Functional safety (SIL2/SIL3)

- Liquicap M FTI51, FTI52
SD00278F/00/en

Control Drawings (FM and CSA)

- Liquicap M FTI51, FTI52
CSA ZD00221F/00/en
- Liquicap M FTI51, FTI52
FM ZD00220F/00/en

CRN registration

- CRN OF1988.75

10.8.3 Patents

This product is protected by at least one of the patents listed below.
Further patents are under development.

- DE 103 22 279,
WO 2004 102 133,
US 2005 003 9528
- DE 203 13 695,
WO 2005 025 015

Index

A

- Activating fault diagnostics 71
- Alarm response 62, 65
- Aligning the housing..... 28

B

- Basic settings 46
- buildup mode..... 53

C

- Cable specification 30
- Carrying out empty and full calibration 50
- Carrying out empty calibration 48
- Carrying out full calibration 49
- CE mark 12
- Commissioning 46
- Connection 32, 41

D

- Declaration of conformity 12
- Declaration of contamination 73
- Designated use 3
- Display elements 42
- Disposal 73

E

- Electromagnetic compatibility (EMC) 30
- Exterior cleaning 69

F

- Firmware history 73
- Functional safety (SIL) 56

G

- Ground tube 17

I

- Inactive length 17
- Incoming acceptance 13
- Installation 13
- Installation conditions..... 27
- Installation instructions..... 14
- Installation tools 27

M

- Maintenance 69
- Measuring conditions..... 16
- MIN/MAX failsafe mode 56

N

- Nameplate 5

O

- Operational safety. 3
- Output signal FEI51 60
- Output signal FEI52 60
- Output signal FEI53 63

- Output signal FEI54 61
- Output signal FEI55 61
- Output signal FEI57S 64, 68
- Output signals 60

P

- Pipe mounting 23
- Post-installation check 29
- Potential equalization 30
- Protective cover 70

R

- Repair..... 69
- Repairing Ex-certified devices 69
- Replacement..... 69
- Reset 51
- Restoring factory settings 59
- Return 73
- Rod probes 16
- Rope probes 19

S

- Safety conventions and symbols 4
- Safety instructions..... 3
- Sealing (housing) 28
- Sealing the probe housing..... 28
- Seals..... 69
- Self-test 55
- Separate housing (Shortening the connecting cable)... 24, 26
- Setting the measuring range 47, 63
- Shortening the connecting cable 24
- Shortening the rope 20
- Spare Parts 72
- Storage..... 13
- Storage temperature 13
- Switch point adjustment..... 52
- Switching delay 54

T

- Technical Information..... 80
- Tensioning weight 20
- Tensioning weight with bracing 20
- Troubleshooting 71
- Troubleshooting instructions..... 71
- Turning the housing 28
- Two-point control..... 53

U

- Upload/download sensor DAT 58
- User interface 42

W

- Wall holder unit 22
- Wall mounting 22
- Wiring 30

Declaration of Hazardous Material and De-Contamination *Erklärung zur Kontamination und Reinigung*

RA No.

Please reference the Return Authorization Number (RA#), obtained from Endress+Hauser, on all paperwork and mark the RA# clearly on the outside of the box. If this procedure is not followed, it may result in the refusal of the package at our facility.
Bitte geben Sie die von E+H mitgeteilte Rücklieferungsnummer (RA#) auf allen Lieferpapieren an und vermerken Sie diese auch außen auf der Verpackung. Nichtbeachtung dieser Anweisung führt zur Ablehnung ihrer Lieferung.

Because of legal regulations and for the safety of our employees and operating equipment, we need the "Declaration of Hazardous Material and De-Contamination", with your signature, before your order can be handled. Please make absolutely sure to attach it to the outside of the packaging.

Aufgrund der gesetzlichen Vorschriften und zum Schutz unserer Mitarbeiter und Betriebseinrichtungen, benötigen wir die unterschriebene "Erklärung zur Kontamination und Reinigung", bevor Ihr Auftrag bearbeitet werden kann. Bringen Sie diese unbedingt außen an der Verpackung an.

Type of instrument / sensor
Geräte-/Sensortyp _____

Serial number
Seriennummer _____

Used as SIL device in a Safety Instrumented System / *Einsatz als SIL Gerät in Schutzeinrichtungen*

Process data / *Prozessdaten* Temperature / *Temperatur* _____ [°F] _____ [°C] Pressure / *Druck* _____ [psi] _____ [Pa]
Conductivity / *Leitfähigkeit* _____ [µS/cm] Viscosity / *Viskosität* _____ [cp] _____ [mm²/s]

Medium and warnings
Warnhinweise zum Medium



	Medium / concentration <i>Medium / Konzentration</i>	Identification CAS No.	flammable <i>entzündlich</i>	toxic <i>giftig</i>	corrosive <i>ätzend</i>	harmful/ irritant <i>gesundheitsschädlich/ reizend</i>	other * <i>sonstiges*</i>	harmless <i>unbedenklich</i>
Process medium <i>Medium im Prozess</i>								
Medium for process cleaning <i>Medium zur Prozessreinigung</i>								
Returned part cleaned with <i>Medium zur Endreinigung</i>								

* explosive; oxidising; dangerous for the environment; biological risk; radioactive

* *explosiv; brandfördernd; umweltgefährlich; biogefährlich; radioaktiv*

Please tick should one of the above be applicable, include safety data sheet and, if necessary, special handling instructions.

Zutreffendes ankreuzen; trifft einer der Warnhinweise zu, Sicherheitsdatenblatt und ggf. spezielle Handhabungsvorschriften beilegen.

Description of failure / *Fehlerbeschreibung* _____

Company data / *Angaben zum Absender*

Company / <i>Firma</i> _____	Phone number of contact person / <i>Telefon-Nr. Ansprechpartner:</i> _____
Address / <i>Adresse</i> _____	Fax / E-Mail _____
_____	Your order No. / <i>Ihre Auftragsnr.</i> _____

"We hereby certify that this declaration is filled out truthfully and completely to the best of our knowledge. We further certify that the returned parts have been carefully cleaned. To the best of our knowledge they are free of any residues in dangerous quantities."

"Wir bestätigen, die vorliegende Erklärung nach unserem besten Wissen wahrheitsgetreu und vollständig ausgefüllt zu haben. Wir bestätigen weiter, dass die zurückgesandten Teile sorgfältig gereinigt wurden und nach unserem besten Wissen frei von Rückständen in gefährlicher Menge sind."

(place, date / *Ort, Datum*)

Name, dept./*Abt.* (please print / *bitte Druckschrift*)

Signature / *Unterschrift*

www.endress.com/worldwide

Endress+Hauser 

People for Process Automation

