

pH measurement in industrial processes

Selection and engineering guide for different industries and applications



Step by step

pH determination is an essential measurement in all industries. Monitoring of product quality or of chemical reactions is often done by means of pH measurement. The pH value is related to the hydrogen ion (H^+) concentration in an aqueous solution and therefore to the solution's acidity. The pH value can (in theory) vary in water between 0 – 14, with 0 being the acidic and 14 the caustic end of the scale.

Application conditions for pH measurement can be very different ranging e.g. from wastewater and chemical mixtures to ultra pure water in power stations or the life science industry.

The lifetime of a pH sensor depends on these conditions, but as well on cleaning, calibration, regeneration intervals and on the right choice of sensor type. A complete pH measuring point consists of the sensing element (pH sensor), an assembly, cable and transmitter. This guide helps you with the selection of the right sensor and assembly for your applications including the transmitter.

For further detailed information, also cross check the related Technical Information of the chosen products. This guide does not claim to be complete.

Overview of pH measurement equipment

This part comprises a short description of different types of necessary components:

- pH sensors
- Assemblies
- Transmitters

Each part contains technical descriptions followed by tables summarizing technical data including advantages and application limits.

Check list/data sheet

For a complete specification a check list is provided with the option to add a sketch of the installation conditions. Please use this format for professional inquiries.

A

Selection of pH sensor according to application

Starting with a flow chart [3.1] this part supports you to do a proper pre-selection based on chemical and physical behaviors of the process medium. From there you are directed to the individual chapters [3.2 – 3.8] with the indication of the recommended pH sensor including key advantages as well as application limits and alternatives.

B

Selection of assembly for a given application

After pH sensor selection, the assemblies part also starts with a flow chart [4.1] guiding to the individual chapters [4.2 - 4.5] based on installation and application conditions. Similar to part B you will be given a first choice plus alternatives.

Depending on pH sensor “liquid- or gel-filled” you need to specify respectively order corresponding options of a retractable assembly. Additionally, make sure to select a pneumatically driven retractable assembly in case you want to use Liquiline Control for automatic measuring, cleaning and calibration.

Based on the selected pH sensor in part B please check mechanical compatibility [table in 4.6] to verify corresponding pH sensor length and max. required free space for mounting assemblies e.g. in pipes, bypasses or small tanks.

C

Contents

1. Overview of pH sensors and installation types	4
1.1 Sensor types	4
1.2 pH sensors	6
1.3 Assembly types	10
1.4 pH assemblies	12
1.5 Transmitter types for pH measurement	20
1.6 pH transmitters	22
2. Check list/data sheet	24
3. Selection of pH sensors according to applications	26
3.1 Flow chart for pH sensor selection	27
3.2 Application: Standard	28
3.3 Application: High organic load	30
3.4 Application: Low conductivity	32
3.5 Application: Hygienic	34
3.6 Application: Heavy-duty – abrasive	36
3.7 Application: High risk of build-up	38
3.8 Application: Chemically demanding	40
4. Selection of assembly	42
4.1 Flow chart for assembly selection	43
4.2 Immersion type	44
4.3 Fixed installation	46
4.4 Retractable assembly (with piston sealing)	48
4.5 Retractable assembly (with ball valve)	50
4.6 Required pH sensor length and immersion depth for various assemblies	52
5. Life cycle management of pH loops	54
5.1 Optimum calibration concept for the lab thanks to Memosens and Memobase Plus	54
5.2 Fully automatic measuring, calibration, sterilization and cleaning	55
5.3 Lifetime of pH sensors	56
5.4 Accreditation for permanent buffer laboratory	57
5.5 Steam/water analysis systems	58

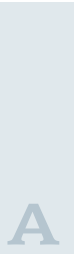

1. Overview of pH sensors and installation types

1.1 Sensor types



Glass sensors

The sensing element of the standard pH-glass sensor is a salt on the glass bulb with a thickness of 100 nm. This layer is able to incorporate H⁺ ions and this results in a change of the electrostatic potential across the glass bulb. This potential change is measured relative to a reference element which is in contact to the medium by the junction to create a closed electrical circuit.

Different types of glass sensors are available, e.g. hygienic and non-hygienic versions. These differ in the kind of junction used (ceramic, Teflon or none) and in the kind of gel or liquid used for the reference system. Resistance of the sensor against blocking of the junction and poisoning of the reference depends strongly on the selection of reference and junction type.



ISFET sensors

The sensing element of an ISFET sensor is a semiconductor chip forming an ion selective field effect transistor. The ISFET chip is especially sensitive to H⁺ ions. Non-glass sensors are unbreakable and the ISFET sensors can tolerate higher amounts of organic solvents than glass type sensors. Glass and ISFET type sensors use the same reference and junction types.

Main application areas of the ISFET type is whenever glass is not allowed or wished, e.g. in food processes or when there are high amounts (> 20 %) of organic solvents. ISFET sensors are made from PEEK and have a lower alkaline and acid error compared to glass sensors. The new generation of the ISFET sensors even offers a six times higher CIP stability compared to conventional ISFET pH sensors.



Combined pH/ORP sensors

Combined sensors feature a platinum element in addition to the pH glass. This enables simultaneous measurement of pH value and ORP potential for a better process overview. Alternatively, the platinum element can be used for measurement of the reference impedance to anticipate decreases in sensor quality. Combined sensors directly deliver rH values that give information about a medium being oxidizing, neutral or reducing.

Different types of glass sensors are available, e.g. hygienic and non-hygienic versions. These differ in the type of junction used (ceramic, Teflon or none). Resistance of the sensor against blocking of the junction depends strongly on the selection of junction type.



Enamel sensor

The main advantage of enamel sensors is their robustness. The sensors have extraordinarily long calibration cycles and a long lifetime. The measurement accordingly requires less maintenance.

Liquid KCl filled reference with hygienic ceramic junction. The linear range is from pH 0 to 10. The sensor has a hygienic design, suitable for CIP and SIP. A retractable assembly is not necessary and there are different process connections available.



Revolutionary Memosens technology



pH measurement has become easier and more reliable since Endress+Hauser has invented Memosens. Inductive signal and energy transmission without any metallic contacts between sensor head and cable connection ensures trouble-free operation even in humid environments. The storage of calibration data in the sensor head enables comfortable calibration in the laboratory and quick sensor exchange on site.





Memosens 2.0 is leading Memosens technology into the future. It offers: Perfect basis for IIoT connectivity: You have the relevant information on your measuring point close to hand using the right app. Predictive maintenance 2.0: The storage capacity for up to 8 times more relevant data is an excellent basis for predicting maintenance requirements. Increased flexibility when configuring the measuring point in hazardous areas.

See also section 5.1 on page 54 or www.endress.com/memosens

1. Overview of pH sensors and installation types



1.2 pH sensors

	Glass sensors Memosens CPS11E Orbisint CPS11	Glass sensors Memosens CPS71E Ceragel CPS71	Glass sensor Memosens CPS61E
			
pH range	0 to 14	0 to 14	1 to 12 (measuring range), 1 to 14 (application)
Process temperature	0 to 135 °C	0 to 135 °C	0 to 140 °C
Max. process pressure	up to 17 bar _{abs}	up to 14 bar _{abs}	up to 7 bar _{abs}
Min. conductivity	50 µS/cm version with salt storage: 0,1 µS/cm	10 µS/cm	100 µS/cm
Organic content	< 20 vol%	< 20 vol%	< 20 vol%
Shaft material	glass	glass	glass
Junction	PTFE	ceramic	ceramic
Reference system	gel filled	gel filled, ion trap	gel filled, ion trap
Special options	F glass for higher HF content, ion trap for poisoning media, salt storage for low conductivity	pressurized reference, upside-down mounting	Certified life sciences and food compliance (e.g. FDA, USP, EHEDG, ...) pressurized reference, upside-down mounting
Applications	water, wastewater, process	chemical processes	hygienic and sterile applications (sterilizable, autoclavable) <ul style="list-style-type: none"> ■ bioreactor/fermenter ■ biotechnology ■ foods

<p>Glass sensors Memosens CPS91E Orbipore CPS91</p> 	<p>Glass sensors Memosens CPS41E Ceraliquid CPS41</p> 	<p>Glass sensors Memosens CPF81E Orbipac CPF81</p> 	<p>Glass sensor Memosens CPS31E Ceratrix CPS31</p> 	<p>Enamel sensor Ceramax CPS341D</p> 
0 to 14	0 to 14	0 to 14	1 to 12	0 to 10 (measuring range), 1 to 14 (application)
0 to 110 °C	0 to 135 °C	0 to 110 °C	0 to 80 °C	0 to 140 °C
up to 14 bar _{abs}	up to 11 bar _{abs} with counter pressure	up to 11 bar _{abs}	up to 4 bar _{abs}	up to 7 bar _{abs}
500 µS/cm	0.1 µS/cm	50 µS/cm	100 µS/cm 50 µS/cm for „AC“ version (three junctions)	50 µS/cm
< 20 vol%	higher level possible depending on application	< 20 vol%	< 20 vol%	< 20 vol%
glass	glass	glass	glass	enamel on stainless steel
open	ceramic	PTFE	ceramic	ceramic
stabilized gel reference	liquid filled	gel filled, double chamber	gel filled	liquid filled
for soiling media		flat membrane	salt storage	
emulsions, suspensions, precipitation reactions	process, ultrapure water, fat, dye	wastewater, mining	drinking water, swimming pool water, pH compensation for measuring free chlorine	food and life sciences

1. Overview of pH sensors and installation types

1.2 pH sensors

	ISFET sensors Memosens CPS77E	ISFET sensors Memosens CPS97E	ISFET sensors Memosens CPS47E
			
pH range	0 to 14	0 to 14	0 to 14
Process temperatur	-15 to 135 °C	-15 to 110 °C	-15 to 135 °C
Max. process pressure	up to 11 bar _{abs}	up to 11 bar _{abs}	up to 11 bar _{abs}
Min. conductivity	10 µS/cm	500 µS/cm	5 µS/cm
Organic content	high level possible depending on application	high level possible depending on application	high level possible depending on application
Shaft material	PEEK, chip sealing: perfluorelastomer	PEEK, chip sealing: perfluorelastomer	PEEK, chip sealing: perfluorelastomer
Junction	ceramic	open aperture	ceramic
Reference system	gel filled	stabilized gel reference	liquid filled
Special options	Certified life sciences and food compliance (e.g. FDA, USP, EHEDG, ...)		Certified life sciences and food compliance (e.g. FDA, USP, EHEDG, ...)
Applications	food, life sciences, fermenter, process, non aqueous media	emulsions, suspensions, precipitation reactions, non aqueous media	process, pure water, fat, dye, non aqueous media

Combined pH/ORP sensor
Memosens CPS16E



Combined pH/ORP sensor
Memosens CPS76E



Combined pH/ORP sensor
Memosens CPS96E



pH: 0 to 14
ORP: -1500 to 1500 mV
rH: 0 to 42

0 to 135 °C

up to 17 bar_{abs}

50 μS/cm

< 20 vol%

glass

PTFE

gel filled, ion trap

water, wastewater, process

pH: 0 to 14
ORP: -1500 to 1500 mV
rH: 0 to 42

0 to 140 °C

up to 14 bar_{abs}

10 μS/cm

< 20 vol%

glass

ceramic

gel filled, ion trap

pressurized reference system, upside-down mounting

chemical process

pH: 0 to 14
ORP: -1500 to 1500 mV
rH: 0 to 42

0 to 110 °C

up to 14 bar_{abs}

500 μS/cm

< 20 vol%

glass

open aperture

stabilized gel reference

emulsions, suspensions, precipitation reactions

1. Overview of pH sensors and installation types

1.3 Assembly types



Immersion type holders

These types of assemblies are mainly used for installations in open vessels and channels. Such assemblies are usually found in wastewater treatment plants or chemical industry. When installation from top of the container or vessels is the only possibility – immersion holders are as well a good choice.

Dipfit

The standard CPA111 made from polypropylene (PP) is mainly used in the wastewater market. Beside that we offer the CPA140 made from PVDF or stainless steel for harsher applications (e.g. chemical industry). Different immersion lengths are available and both assemblies can hold up to three sensors for redundant or multiple measurement. Spray cleaning options are available for both assemblies.



Modular immersion type holders

These types of assemblies have real advantages in immersion applications like in wastewater industries. They are suitable for sensors with various connection threads. Not only 12 mm glass sensors for pH or oxygen but also sensors for turbidity or nitrate. The System can be mounted in nearly all locations (pipes, rails, etc.) by using different pipes, holders and more.

The modular system allows an optimum configuration for every measuring application

- Using 12 mm Memosens sensors
- Versions in stainless steel or PVC
- Assembly length from 600 mm (23.6") to 3600 mm (142") in steps of 600 mm (23.6")
- A float assembly is available for varying water levels.
- Quick fastener for:
 - fast installation and exchange of Memosens sensors with non-contact plug-in head
 - twist-free installation of fixed-cable sensors
 - alignment of sensors

Flexdip

Flexdip CYA112 is used for installations in open vessels and channels. Such assemblies are usually found in wastewater treatment plants.



Insertion assemblies

Especially in batch processes where you have access to the pH sensor between two batches we find fixed installations realized by using insertion assemblies. Such assemblies are often used in life sciences and food production.

Unifit

The CPA842 is an assembly made from stainless steel for food and life sciences. There are several options for the process connection especially hygienic clamp connections. For special hygienic demands a certified hygienic design and certificates according to EHEDG, 3-A, ASME BPE and Pharma CoC are available with corresponding surface roughness.



Flow-through assemblies

Installation in process pipes or bypasses can be done by using flow-through type assemblies. Such set-ups are often found in water works, beverages industry, chemical industry or on analytical panels in power plants.

Flowfit

For the water works segment the CPA250 made from polypropylene (PP) is a good choice. The robust CPA240, available in chemically resistant PVDF or made from stainless steel is made for measurement of ultra pure water (prevention of static charges). Both assemblies provide 3 sensor slots and the possibility to upgrade for chemical spray cleaning. For compact installations and utilities, the CYA21 could be a valuable option.



Retractable assemblies

Main advantage of retractables is that sensor exchange or cleaning can easily be done without process interruption. Insertion or retraction can either be done manually or automatically (pneumatic retraction). The pneumatically driven assemblies can be combined with automatic cleaning and calibration system, because the sensor resides in a cleaning chamber after retraction.

Cleanfit

Besides the differentiation between manual and automatic retraction, we offer different materials, sealing strategies to the process and safety functions to fit your application. For heavy duty applications, variants with a ball valve based sealing system are available. Additionally the pneumatic version can be combined with the fully automated measuring, cleaning and calibration solution Liquiline Control.



Liquiline Control

Fully automated measuring, cleaning and calibrating



- 1 Media distribution unit
- 2 Transmitter with industry PC and touch display
- 3 Cleaner and buffer canisters
- 4 Double-membrane pumps

See also section 5.2 on page 55 or www.endress.com/CDC90

1. Overview of pH sensors and installation types

1.4 pH assemblies

(Type of sensor see table on page 52)

	Flowfit CPA240	Flowfit CPA250	Flowfit CYA21
			
Max. process pressure	Stainless steel: 11 bar _{abs} at 150 °C; PVDF: 9 bar _{abs} at 50 °C	7 bar _{abs} at 20 °C	17 bar _{abs}
Process temperature	Stainless steel: -15 to 150 °C PVDF: 0 bis 120 °C	0 to 80 °C	0 to 100 °C
Materials (in contact with medium)	PVDF, stainless steel 1.4404/316L	Polypropylene (PP)	Stainless steel 1.4404/316L
Sealings (in contact with medium)	EPDM/Viton/Chemraz/Fluoraz	Viton/FKM	specific to sensor
Sensor connections	3 x PG 13.5	3 x PG 13.5	1 x PG 13.5; thread NPT 1/2"
Process connections	welding adapter for DN 25 pipe; flange DN 25 PN 16; flange ANSI 1" 150 lbs; flange JIS 10K 25 A; thread FNPT 1/2"	thread G 1", thread NPT 1"	pipe, 6mm outer diameter (OD) for common tube fitting systems
Cleaning	spray cleaning CPR31	spray cleaning CPR31, Chemiclean CPR3	-
Remarks	PMC (potential matching) in Alloy C4; Tantal	PWIS-free version available	compact design; ideal for limited space applications
Applications	water, boiler feedwater, ultra pure water, cooling water, fertilizer, sugar production, gas scrubbers, petrochemical	water, wastewater treatment or beverages	water, boiler feedwater, ultra pure water, cooling water

Unifit CPA842

17 bar_{abs}

-15 to 140 °C

Stainless steel 1.4435/316L

EPDM-FDA, FKM, FKM-FDA, silicone-FDA

1 x PG 13.5

DN 25 standard; DN 25 also for B.Braun port; Tri-Clamp 1.5"; Tri-Clamp 2"; dairy fitting DN 50 DIN11851; Varivent DN 40-125/0.4", aseptic fitting DN50 thread DIN 11864-1A

-

EHEDG approval with surface finish $R_a = < 0.76 \mu\text{m}$ or $< 0.38 \mu\text{m}$, 3-A

food, life sciences, chemical, water

1. Overview of pH sensors and installation types

1.4 pH assemblies

(Type of sensor see table on page 52)

	Ecofit CPA640	Dipfit CPA111
		
Max. process pressure	11 bar _{abs} at 90 °C, metal 11 bar _{abs} at 20 °C, PVDF	5 bar _{abs} at 20 °C
Process temperature	0 to 140 °C	-10 to 80 °C
Material (in contact with medium)	PVDF, stainless steel 1.4571/316Ti, Monel	Polypropylene (PP)
Sealings (in contact with medium)	Viton	EPDM
Sensor connections	1 x PG 13,5	3 x PG 13,5
Process connections	M-NPT 1/2"; M-NPT 3/4"; thread M 25 x 1.5	flange DN 100; adjustable flange DN 100; suspension bracket
Cleaning	-	external spray cleaning CPR30, internal spray cleaning CPR31
Remarks	application of glass sensors with 3/4" process connections	wet bucket
Applications	water, wastewater, flocculant dosage, surface water, industrial water monito- ring, wastewater neutralisation	water/wastewater

Dipfit CPA140



Flexdip CYA112





	11 bar _{abs} at 150 °C, metal 7 bar _{abs} at 20 °C, PVDF	1 bar _{abs}	
	PVDF: 0 to 120 °C Stainless steel: -15 bis 150 °C, with EPDM seal: -15 to 140 °C	0 to 60 °C	
	PVDF, stainless steel 1.4404/316L	PVC, stainless steel 1.4404/316L	
	EPDM/Viton/Chemraz/ Fluoraz	EPDM	
	3 x PG 13,5	1 x PG 13,5 or 1x NPT3/4" (female)	
	flange DN 80 PN16; flange ANSI 3" 150 lbs; flange JIS 10K 80A	thread G 3/4", 1"; thread NPT 3/4"; 1 x PG13,5	
	external spray cleaning CPR30, internal spray cleaning CPR31	-	
	mounting of KCl reservoir onto the assembly	modular system, many accessories	
	chemical industry, pesticides and fertilizers, petrochemical, power plants, metal industry	water/wastewater treatment, plant design, open channels, basins, open tanks and process vats, fluctuating water levels	

1. Overview of pH sensors and installation types

1.4 pH assemblies

(Type of sensor see table on page 52)

	Cleanfit CPA871	Cleanfit CPA875
		
Max. process pressure	17 bar _{abs} (depending on version)	17 bar _{abs} at 140 °C
Process temperature	-10 bis 140 °C (depending on version)	-10 to 140 °C
Material (in contact with medium)	Stainless steel 1.4404/316L, Alloy C22 PEEK, PVDF, PVDF conductive	Stainless steel 1.4435/316L, Alloy C22
Sealings (in contact with medium)	EPDM/FKM/FFKM	EPDM-FDA/FKM-FDA/FFKM-FDA
Operation	manual/ pneumatic	manual/ pneumatic
Sensor connections	1 x PG 13,5	1 x PG 13,5
Process connections	clamp 2", 2½"; flange DN 40, DN 50, DN 80; flange 2", 3" (ASME B16.5); flange JIS 10K50, 10K80; thread NPT 1½"; thread G 1¼"; dairy fitting DN 50, DN 65	clamp 1½", 2", 2½"; aseptic DN 25, DN 50; Neumo Biocontrol D 65; Neumo Bioconnect D 50, D 65; dairy fitting DN 50, DN 65; thread G 1¼"; Varivent flange
Convertible to pneumatic	yes	yes
Sealing to process	O-rings (2x)	gasket, (version with thread G1 1/4": O-ring)
Special options	immersion chamber version, 3.1 certificate	double chamber version
Applications	water, wastewater, process	food and life sciences processes

Cleanfit CPA450



Cleanfit CPA451



5 bar_{abs} at 130 °C,
13 bar_{abs} (static, no movement
of the assembly allowed)

-15 to 130 °C

Stainless steel 1.4404/316L,
Hastelloy C22 , Titanium

EPDM/FKM/FFKM

manual

1 x PG 13,5

G1½" internal; G1¼" external; NPT 1¼"
external; flange DN32 ISO 1092-1;
flange ANSI 1¼"; G1¼" internal; NPT 1¼"
external; M-NPT 1½" external; flange
ANSI 2"

no

ball valve

Safety kit for higher process pressure,
3.1 certificate

water, wastewater, process

3 bar_{abs} at 80 °C,
11 bar_{abs} (static, no movement
of the assembly allowed)

0 to 80 °C

Stainless steel 1.4404/316L

FKM

manual

1 x NPT 3/4" (female)

G2" , flange DN50 Iso 1092-1,
Flange 2" ANSI

no

ball valve



Welding socket

water, wastewater

1. Overview of pH sensors and installation types

1.4 pH assemblies

(Type of sensor see table on page 52)

	Cleanfit CPA472D	Cleanfit CPA473
		
Max. process pressure	11 bar _{abs} at 100 °C, max. 140 °C	7 bar _{abs} at 100 °C
Process temperature	0 to 140 °C	PA pressure cylinder: max. 80 °C Stainless steel pressure cylinder: 100 °C/6 bar (with continuous operation)
Material (in contact with medium)	PEEK, PVDF, conductive PVDF, Alloy C22, titanium, stainless steel 1.4571/316Ti	Stainless steel 1.4404/316L
Sealings (in contact with medium)	EPDM/FKM/FFKM	EPDM/FKM/FFKM
Operation	manual/ pneumatic	manual/ pneumatic
Sensor connections	1 x PG 13,5	1 x PG 13,5
Process connections	1¼ internal thread flange DN 50, DN 80, 2" ANSI 150 lbs flange JIS 10K 25 A	1¼ internal thread Tri-Clamp 2" dairy fitting DN 65 (DIN 11 851) flange DN 50, 2" ANSI 150 lbs
Convertible to pneumatic	yes	yes
Sealing to process	O-rings (3x)	ball valve
Special options	various flow assemblies PFA-lined, 3.1 certificate	flow chamber, optionally with scrapers
Applications	heavy-duty and process applications	chemical industry, paper industry, sticky media

Cleanfit CPA474



7 bar_{abs} at 80 °C

PP: 0 to 60 °C
PVDF/PEEK: 0 to 120 °C

Polypropylene (PP)/PEEK/PVDF

EPDM/FKM/FFKM

manual/
pneumatic

1 x PG 13,5

DN 50 (DIN 11 851)
flange DN 50,
2" ANSI 150lbs

yes

ball valve

flow chamber, optionally with scrapers

paper industry, industrial water
treatment

1. Overview of pH sensors and installation types

1.5 Transmitter types for pH measurement



Liquiline CM44 and CM44R

The digital four-wire transmitter offers up to 8 channels. It provides a simple and self-intuitive operation with clear text menu in 17 languages. Thanks to its suitability for measuring 12 different parameters you can mix and match all Memosens sensors in any combination. The Memosens technology is the fundament for predictive maintenance functionalities because it supplies already a lot of digital sensor data and process information.

The Heartbeat Technology available for Liquiline CM44 ensures permanent process and device diagnostics, using functionalities such as the process check system, delta

slope, delta zero point or a calibration timer. This helps you to optimize your maintenance strategy. Heartbeat Technology also comprises verification routines and makes it possible to automatically generate verification reports.

Liquiline CM44 provides up to 8 current outputs 0/4 to 20 mA, up to 4 relays as well as fieldbuses like HART, PROFIBUS DP, Modbus TCP/RTU, EtherNet/IP and Profinet. Besides the four-wire transmitter enables a comfortable remote access via Ethernet webserver. Liquiline multiparameter transmitter is available as field device and as DIN-rail version for mounting in cabinets and on DIN-rails.



Liquiline CM42

Easy and self-intuitive operation with clear text menu in 14 languages is one of your benefits with this two-wire transmitter. In addition it is applicable for Ex and Non-Ex applications. Predictive maintenance function can be used together with our Memosens sensors to indicate e.g. calibration cycles. Parameter change from pH to conductivity or dissolved oxygen is easily done by only exchanging the

sensor. Use Liquiline transmitter or Memobase Plus for calibration of Memosens sensors in the laboratory. Your benefit: Pre-calibrated sensors could be exchanged in the process very quickly and this means considerably fewer interruptions of pH measurement. Available outputs besides 4 to 20 mA and HART are FOUNDATION Fieldbus and PROFIBUS PA.



Liquiline CM14

Liquiline CM14 is a basic transmitter that offers all you need to run a standard measuring point. It fits into the common cabinet cut-outs and is

easy to commission thanks to digital Memosens technology. The Memosens hot plug & play concept allows to quickly install and commission your digital sensors.



Liquiline Compact CM72/CM82

The Liquiline Compact CM72 and CM82 are the smallest transmitters for Memosens sensors and are attached directly to the sensor without their own power supply. As loop-powered two-wire devices, Liquiline compact transmitters can also be directly connected to a programmable logic controller (PLC), which also serves as the power supply. The compact transmitters measure only 11 cm long and 2 cm wide and, together with the sensor, can fit into most assemblies. Despite its slender housing, the Liquiline Compact CM82 offers the complete flexibility and configurability of a multi-parameter

transmitter. In addition, it is easy and reliable to operate and configure via an encrypted Bluetooth connection using a tablet or smartphone. Using the SmartBlue app, you can see all measuring points that are within the Bluetooth range of the device, and configure them and generate diagnostics. The Liquiline Compact CM72 and CM82 can be used in hazardous and non-hazardous areas. This means that measuring points in dangerous or difficult to access locations can be checked and configured from a safe distance.



Liquisys CPM223/CPM253



The Liquisys transmitter is available as a panel mounted version CPM223 or with field housing CPM253. Relay functions are available as an option (e.g. neutralization processes and spray cleaning function). 0/4 to 20 mA, HART or PROFIBUS PA/DP

outputs can be used to connect the device to your PLC.

The transmitter is available for pH, conductivity, dissolved oxygen and chlorine. Advanced diagnostic functions such as detection of glass breakage are optional.

1. Overview of pH sensors and installation types

1.6 pH transmitters

	Liquiline CM44/CM44R	Liquiline CM42
		
Measured parameters	pH glass, pH ISFET, ORP, conductivity, chlorine, oxygen, turbidity, nitrate, SAC, ammonium, sludge level, potassium, chloride	pH glass, pH ISFET, ORP, conductivity, oxygen
Input	Memosens, 4 to 20mA, digital	Memosens, analog
Channels	up to 8	single-channel
Power supply	24V DC/AC (+20/-15%) 100 to 230V AC, 50/60Hz (±15%)	12.5 to 30 V DC (HART, without HART) 9 bis 32 V DC (fieldbus)
Output	up to 8 analog 0/4 to 20 mA, max. 4 digital, 8 relays, alarm relays, fieldbus communication	up to 2 analog 0/4 to 20 mA, fieldbus communication
Display	graphic display with plain text guidance	graphic display with plain text guidance
Degree of protection	field device: IP66/67, NEMA Type 4X; DIN-rail/cabinet controller: IP20; display: IP66	IP66/67, NEMA Type 4X
Communication	HART, PROFIBUS DP, Modbus TCP/RTU, EtherNet/IP, Profinet, Webserver	HART, PROFIBUS PA, FOUNDATION Fieldbus
Housing	plastic	plastic, stainless steel
Mounting	post, rail, DIN-rail, wall	wall, post, panel
Approvals	certificate of quality	certificate of quality, ex approval
Specials	<ul style="list-style-type: none"> ■ 4-wire multiparameter transmitter ■ Heartbeat Technology ■ mathematics functions ■ cleaning function, controller ■ quick setup function ■ modular expandable, SD-Card 	<ul style="list-style-type: none"> ■ 2-wire transmitter ■ quick setup function ■ navigator ■ sensor module replaceable ■ predictive maintenance system ■ also suitable for analog sensors

Liquiline CM14



Liquiline Compact CM72/CM82



Liquisys CPM253/ CPM223



pH glass, ORP, conductivity, oxygen

pH glass, pH ISFET, ORP, conductivity, oxygen

pH glass, pH ISFET, ORP

Memosens

Memosens plug-in head

Memosens, analog,

single-channel

single-channel

single-channel

24 V to 230 V AC/DC wide range power supply

12.6 to 30 V DC

100/115/230 V AC
24 V AC/DC

up to 2 analog 0/4 to 20 mA, 2 limit contactor relays

1 analog 4 to 20 mA

2 analog (linear, optionally with user defined characteristic curve), alarm relays, up to 4 additional relays

2 line, LCD with dot matrix, 7 segment

LED red and green

2 line, LCD

front: IP65, NEMA Type 4X;
housing: IP20

IP 67/68, NEMA Type 6

field device: IP65, NEMA Type 4X;
panel device: IP54 (front), IP30 (housing)

-

CM82: Bluetooth®, HART

HART, PROFIBUS PA, PROFIBUS DP

plastic

PEEK

plastic

panel

space-saving, directly on sensor

wall, post, panel

certificate of quality

certificate of quality, ex approval, radio approval

certificate of quality

- 4-wire transmitter
- compact device for cabinets
- cost-efficient alternative

- 2-wire transmitter
- easy operation/commissioning
- connection via Bluetooth
- operation and configuration by the SmartBlue App
- space-saving installation in assemblies

- 4-wire transmitter
- cleaning via timer, Chemoclean, PID controller
- also suitable for analog sensors

2. Check list

Customer contact data:			
Name:		Company:	
E-mail:		Telephone:	
		Please fill in	Notes
Medium	pH range		
	Conductivity [$\mu\text{S}/\text{cm}$]		
	Sulfides (S^{2-}), cyanides (CN), ammonia (NH_3) [mg/l]		
	Hydrofluoric acid (HF) [mg/l]		
	Organic solvent content [%]		
	Fatty, greasy, sticky media		
	Suspended solids		
	Abrasives		
Process data	Process temperature		
	Max. process pressure		
	Flow velocity		
Process connection	Connection type/size		
Installation	Ambient temperature		
	Installation in pipes		
	Installation in vessel	From top: From side:	
	Bypass installation		
	Sample preparation		
Transmitter	2-/4-wire		
	Ingress protection		
	Digital communication (HART, PROFIBUS, FOUNDATION Fieldbus)		
	Dosing to be controlled by transmitter?		
	Automatic cleaning?		
	Cleaning medium allowed to contaminate medium?		
	Multichannel device		
Approvals/certificates	Ex (Ex ia, Ex d)		
	EHEDG		
	3-A		
	FDA-listed material		
	SIL		
	3.1 certificate		

Customer contact data:	
Name:	Company:
E-mail:	Telephone:

Special demands/short application description/drawing:

A large grid consisting of 20 columns and 20 rows, intended for drawing or detailed notes.

3. Selection of suitable pH sensor

3.1 Flow chart for pH sensor selection

B

Standard application

The selection of a pH sensor is primarily based on chemical and physical behaviors of the process medium. Combinations with process- or industry-specific requirements like hygienic requirements will reduce the choice of pH sensors suitable for certain applications. However, the key criteria are based on maximum expected lifetime and maintenance efforts like calibration or refilling of KCl.

From there you are directed to the individual chapters [3.2 – 3.8] with the indication of the recommended pH sensor including key advantages as well as application limits and alternatives. We simplified the flow chart to reduce complexity. That is why you may find combinations that require contact with specialists.

High organic load

- There are basically 2 approaches:
- a) First choice recommended for a given application
 - b) Verifying a “known” pH sensor for a new “unknown” application

Low conductivity

As some of the conditions might be difficult to predict there is also the choice in the flow chart “unknown”.

Hygienic applications

Heavy-duty applications

High risk of build-up

Chemically demanding

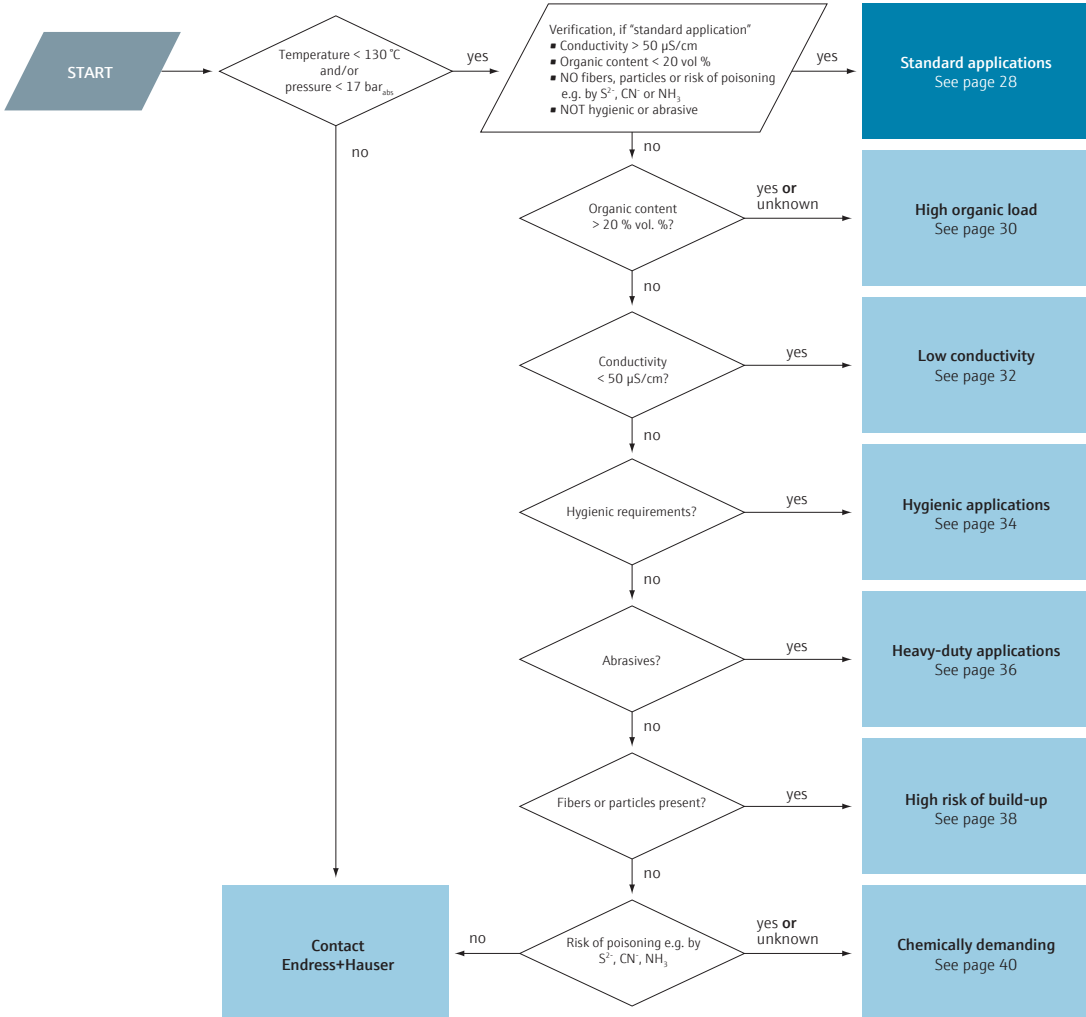



3. Selection of suitable pH sensor

3.2 Application: Standard

B

Standard application

	Our proposal		
	Memosens CPS11E Orbisint CPS11	Memosens CPS16E	Memosens CPF81E Orbipac CPF81
			
Advantages	<ul style="list-style-type: none"> ■ Dirt-repellent PTFE junction ■ Most universal with broad application spectrum ■ CPS16E: simultaneous measurement of pH, ORP and rH values for a better process overview 		<ul style="list-style-type: none"> ■ Dirt-repellent PTFE junction ■ Sensor integrated in plastic holder with thread connection
Technical data	<ul style="list-style-type: none"> ■ Process temperature -15 °C to +80 °C (A glass), 0 °C to 135 °C (B glass) ■ Max. process pressure up to 17 bar_{abs} ■ pH range 1 to 12 (A glass), 0 to 14 (B glass) ■ Sensor lengths 120, 225, 360 and 425 mm ■ Transmission Memosens and TOP68 		<ul style="list-style-type: none"> ■ 0 °C to 80 °C (NN version), 0 to 110 °C (LH version) ■ up to 11 bar_{abs} (80 °C) ■ 0 to 14 ■ Memosens, TOP68 and fixed cable
Application limits	<ul style="list-style-type: none"> ■ Heavily soiling media need spray cleaning – see assembly page 12 ff. ■ Slower response of sensor with PTFE junction 		<ul style="list-style-type: none"> ■ Heavily soiling media need spray cleaning – see assembly page 12 ff. ■ Slower response of sensor with PTFE junction
▶ = alternative product	<ul style="list-style-type: none"> ▶ liquid-filled CPS41/CPS41E with ceramic junction or CPS31E with three ceramic junctions 		<ul style="list-style-type: none"> ▶ liquid-filled CPS41/CPS41E with ceramic junction

Application: Standard		
Conditions	Process	Typ. liquids
<ul style="list-style-type: none"> Conductivity > 50 $\mu\text{S}/\text{cm}$ Organic content < 20 vol % NOT hygienic or abrasive 	<ul style="list-style-type: none"> Neutralization Water treatment 	<ul style="list-style-type: none"> Water Wastewater

Memosens CPS41E
Ceraliquid CPS41



Memosens CPS31E
Ceratex CPS31



<ul style="list-style-type: none"> Fast response time due to ceramic junction and liquid filling More soiling-resistant due to continuous flushing of junction 	<ul style="list-style-type: none"> Fast response time due to ceramic junction Less fouling due to silver chloride filling For chlorine containing applications due to special construction of the reference element 	
<p>-15 °C to 80 °C (A glass), 0 °C to 135 °C (B glass) up to 11 bar_{abs} CPY7B KCl vessel with counter pressure necessary</p> <p>2 to 12 (A glass), 0 to 14 (B glass) 120, 225, 360 and 425 mm Memosens and TOP68</p>	<p>-15 to 80°C</p> <p>up to 4 bar_{abs}</p> <p>1 to 12 120 mm Memosens, TOP68 and KOAX</p>	
<ul style="list-style-type: none"> Manual refilling of electrolyte vessel CPYB7 necessary Heavily soiling media needed spray cleaning – see assembly page 12 ff. 	<ul style="list-style-type: none"> gel-filled CPS11/CPS11E or CPF81/CPF81E 	<ul style="list-style-type: none"> sensitive to soiling media due to small pores of ceramic junction
	<ul style="list-style-type: none"> gel-filled CPS11/CPS11E or CPF81/CPF81E 	

3. Selection of suitable pH sensor

3.3 Application: High organic load

B

High organic load

Our proposal

Memosens CPS47E



Memosens CPS77E



<p>Advantages</p>	<ul style="list-style-type: none"> No aging effect of ISFET chip because of organics Stable and fast measurement due to liquid reference 	<ul style="list-style-type: none"> No aging effect of ISFET chip because of organics Up to 95 % organic content possible
<p>Technical data</p> <ul style="list-style-type: none"> Process temperature Max. process pressure pH range Sensor lengths Transmission 	<p>-15 °C to 135 °C up to 11 bar_{abs}, KCl vessel CPY7B with counter pressure necessary</p> <p>0 to 14 120, 225, 360 and 425 mm Memosens</p>	<p>-15 °C to 135 °C up to 11_{abs} bar</p> <p>0 to 14 120, 225, 360 and 425 mm Memosens</p>
<p>Application limits</p> <p>▶ = alternative product</p>	<ul style="list-style-type: none"> Hot caustics for long periods e.g. during "CIP" Soiling media Glass sensor CPS41E CPS41E and automatic cleaning with Liquiline Control [see page 55] 	<ul style="list-style-type: none"> Remark: Generally automatic cleaning with Liquiline Control [see page 55] recommended

Application: High organic load

Conditions	Process/industry	Typ. liquids
<ul style="list-style-type: none">Organic content > 20 vol %NO fibers, particles or risk of poisoning e.g. by S^{2-}, CN^- or NH_3NOT abrasive	<ul style="list-style-type: none">Dye and pigment production	<ul style="list-style-type: none">Impregnating resin

B



High organic load

3. Selection of suitable pH sensor

3.4 Application: Low conductivity

B

Low conductivity

		Our proposal			
		Memosens CPS11E-xAS Orbisint CPS11		Memosens CPS41E Ceraliquid CPS41	
					
		With salt storage			
Advantages		<ul style="list-style-type: none"> No electrolyte refilling necessary 		<ul style="list-style-type: none"> Fast response time due to ceramic junction and liquid filling Extended lifetime because of continuous electrolyte refilling 	
Technical data					
<ul style="list-style-type: none"> Process temperature 		-15 °C to 80 °C (A glass)		-15 °C to 80 °C (A glass), 0 °C to 135 °C (B glass)	
<ul style="list-style-type: none"> Max. process pressure 		up to 7 _{abs} bar		up to 11 bar _{abs} , KCl vessel CPY7B with counter pressure necessary	
<ul style="list-style-type: none"> pH range Sensor lengths Transmission 		1 to 12 (A glass) 120, 225, 360 and 425 mm Memosens and TOP68		2 to 12 (A glass), 0 to 14 (B glass) 120, 225, 360 and 425 mm Memosens and TOP68	
Application limits					
<ul style="list-style-type: none"> = alternative product 		<ul style="list-style-type: none"> Limited lifetime of approx. 6 months until salt storage is used up 	<ul style="list-style-type: none"> CPS41/CPS41E 	<ul style="list-style-type: none"> Manual refilling of electrolyte vessel necessary Chance of continuous outflow of KCl traces 	<ul style="list-style-type: none"> Gel-filled CPS11/CPS11E with salt storage CPS11/CPS11E

Application: Low conductivity

Conditions	Process/industry	Typ. liquids
<ul style="list-style-type: none">▪ Conductivity < 50 $\mu\text{S}/\text{cm}$▪ NO fibers, particles or risk of poisoning e.g. by S^{2-}, CN^- or NH_3▪ NOT abrasive	<ul style="list-style-type: none">▪ Power	<ul style="list-style-type: none">▪ Boiler water▪ Pure/ultra pure water

B



Low conductivity

3. Selection of suitable pH sensor

3.5 Application: Hygienic

B

Hygienic applications

		Our proposal			
		Memosens CPS61E		Memosens CPS77E	
					
Advantages		<ul style="list-style-type: none"> ▪ "Certificate of compliance" for bio-compatibility available – CIP/SIP resistant ▪ Pressurized reference version available for better resistance against blocking ▪ Upside down version for small fermenters 		<ul style="list-style-type: none"> ▪ Non-glass ISFET sensor ▪ "Certificate of compliance" for bio-compatibility available 	
Technical data					
▪ Process temperature		0 °C to 135 °C		-15 °C to 135 °C	
▪ Max. process pressure		up to 14 bar _{abs} , up to 11 bar _{abs} for upside down version, up to 7 bar _{abs} for pressurized reference		up to 11 bar _{abs}	
▪ pH range		0 to 14		0 to 14	
▪ Sensor lengths		120, 225, 360 and 425 mm		120, 225, 360 and 425 mm	
▪ Transmission		Memosens		Memosens	
Application limits					
▶ = alternative product		▶ Risk of glass breakage	▶ Non-glass ISFET sensors CPS77E/ CPS47E	<ul style="list-style-type: none"> ▪ Hot caustics for long periods e.g. during "CIP" ▪ Soiling media 	<ul style="list-style-type: none"> ▶ Retract sensor during cleaning cycle or use CPS61E ▶ CPS61E and/or automatic cleaning [see page 55]

Application: Hygienic		
Conditions	Process/industry	Typ. liquids
<ul style="list-style-type: none"> Organic content < 20 vol % NOT abrasive 	<ul style="list-style-type: none"> Food Life sciences 	<ul style="list-style-type: none"> Fermentation WFI (water for injection)

Memosens CPS47E



Ceramax CPS341D



<ul style="list-style-type: none"> Non-glass ISFET sensor Liquid-filled reference to prevent blocking 	<ul style="list-style-type: none"> Long term stability Less calibration Lifetime up to approx. 5 years Less risk of breakage Direct mounting in process with hygienic process connection Fast response Highly viscous media 	
<p>-15 °C to 135 °C</p> <p>up to 11 bar_{abs}, KCl vessel CPY7B with counter pressure necessary</p> <p>0 to 14</p> <p>120, 225, 360 and 425 mm Memosens</p>	<p>0 °C to 140 °C</p> <p>up to 7 bar_{abs}</p> <p>0 to 10 (measuring range), 1 to 14 (application)</p> <p>– Memosens</p>	
<ul style="list-style-type: none"> Hot caustics for long periods e.g. during "CIP" Soiling media 	<ul style="list-style-type: none"> Manual refilling of electrolyte vessel necessary Significantly higher investment costs than standard sensor 	<ul style="list-style-type: none"> Retract sensor during cleaning cycle or use CPS61E, CPS71E Automatic cleaning [see page 55] and/or CPS61E, CPS71E gel-filled CPS61E or CPS77E

3. Selection of suitable pH sensor

3.6 Application: Heavy-duty – abrasive

B



Advantages	<ul style="list-style-type: none"> Flat membrane prevents glass abrasion Double chamber reference offers better protection against poisoning 	<ul style="list-style-type: none"> Sensor design allows mounting of sensing element in "flow shadow" 	
Technical data	<ul style="list-style-type: none"> Process temperature: 0 °C to 80 °C (NN version), 0 to 110 °C (LH version) Max. process pressure: up to 11 bar_{abs} (80 °C) pH range: 0 to 14 Sensor lengths: – Transmission: Memosens, TOP68 and fixed cable 	<ul style="list-style-type: none"> -15 °C to 110 °C up to 11 bar_{abs} 0 to 14 120, 225, 360 and 425 mm Memosens 	
Application limits	<ul style="list-style-type: none"> Strongly abrasive particles will reduce lifetime 	<ul style="list-style-type: none"> ISFET CPS97E 	
▶ = alternative product		<ul style="list-style-type: none"> Open junction means less protection against poisoning 	<ul style="list-style-type: none"> CPF81/CPF81E

Heavy-duty applications

Application: Heavy-duty – abrasive

Conditions	Process/industry	Typ. liquids
<ul style="list-style-type: none">▪ Conductivity > 50 $\mu\text{S}/\text{cm}$▪ Organic content < 20 vol %▪ NOT hygienic	<ul style="list-style-type: none">▪ Mining	<ul style="list-style-type: none">▪ Slurries

B

Heavy-duty applications

3. Selection of suitable pH sensor

3.7 Application: High risk of build-up

B

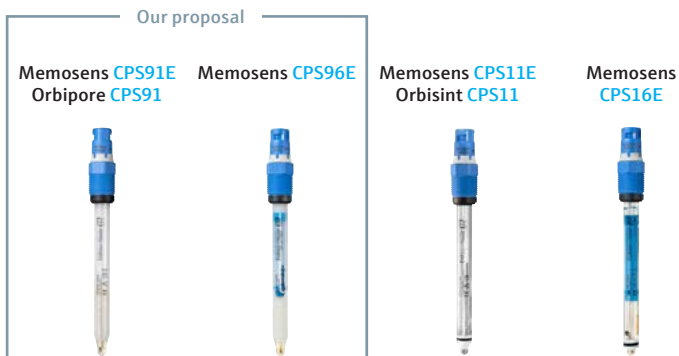

Advantages	<ul style="list-style-type: none"> ■ Open junction is less prone to blocking ■ Good poison resistance due to ion trap of CPS96E or CPS91E "TH version" ■ CPS96E: Simultaneous measurement of pH, ORP and rH values for better process overview 		<ul style="list-style-type: none"> ■ Dirt-repellent PTFE junction ■ Most universal with broad application spectrum ■ Excellent poison resistance due to ion trap of CPS16E and CPS11E "TA version" ■ CPS16E: Simultaneous measurement of pH, ORP and rH values for better process overview 	
Technical data	<ul style="list-style-type: none"> ■ Process temperature: 0 °C to 110 °C ■ Max. process pressure: up to 14 bar_{abs} ■ pH range: 0 to 14 ■ Sensor lengths: 120, 225, 360 and 425 mm ■ Transmission: Memosens and TOP68 (CPS91) 		<ul style="list-style-type: none"> ■ Process temperature: -15 °C to 80 °C (A glass), 0 °C to 135 °C (B glass) ■ Max. process pressure: up to 17 bar_{abs} ■ pH range: 1 to 12 (A glass), 0 to 14 (B glass) ■ Sensor lengths: 120, 225, 360 and 425 mm ■ Transmission: Memosens and TOP68 (CPS11) 	
Application limits	<ul style="list-style-type: none"> ▶ = alternative product ■ Extreme risk of poisoning ■ Heavily soiling media 		<ul style="list-style-type: none"> ▶ CPS11/CPS11E with option "TA", CPS16E ▶ automatic cleaning [see page 55] ■ With small particle sizes risk of blocking ▶ CPS91/CPS91E, CPS96E 	

High risk of build-up

Application: High risk of build up

Conditions	Process/industry	Typ. liquids
<ul style="list-style-type: none">▪ Conductivity > 50 $\mu\text{S}/\text{cm}$▪ Organic content < 20 vol %▪ NOT hygienic or abrasive	<ul style="list-style-type: none">▪ Pulp and paper▪ Process industry	<ul style="list-style-type: none">▪ Paper bleaching▪ Emulsions▪ Flue gas desulfurization





B

High risk of
build-up

3. Selection of suitable pH sensor

3.8 Application: Chemically demanding

B

	Our proposal		Memosens CPS11E Orbisint CPS11	Memosens CPS16E
	Memosens CPS71E Ceragel CPS71	Memosens CPS76E		
				
	(TP version)	(TP version)	(TA version)	
Advantages	<ul style="list-style-type: none"> Fast response time without refilling of electrolyte Pressurized reference version for better resistance against poisoning CPS76E: Simultaneous measurement of pH, ORP and rH values for better process overview 		<ul style="list-style-type: none"> Dirt-repellent PTFE junction Excellent poison resistance due to ion trap in the reference Most universal with broad application spectrum CPS16E: Simultaneous measurement of pH, ORP and rH values for better process overview 	
Technical data	<ul style="list-style-type: none"> Process temperature: 0 °C to 100 °C Max. process pressure: up to 7 bar_{abs} for pressurized reference pH range: 0 to 14 Sensor lengths: 120, 225, 360 and 425 mm Transmission: Memosens and TOP68 (CPS71) 		<ul style="list-style-type: none"> -15 °C to 80 °C (A glass), 0 °C to 135 °C (B glass) up to 17 bar_{abs} 1 to 12 (A glass), 0 to 14 (B glass) 120, 225, 360 and 425 mm Memosens and TOP68 (CPS11) 	
Application limits	<ul style="list-style-type: none"> Limitations in very blocking media 		<ul style="list-style-type: none"> Slower response time due to memory effects of PTFE junction 	<ul style="list-style-type: none"> CPS41/CPS41E or CPS71/CPS71E "TP version", CPS76E „TP version"
▶ = alternative product	▶ CPS41/CPS41E			

Chemically demanding

Application: Chemically demanding		
Conditions	Process/industry	Typ. liquids
<ul style="list-style-type: none"> ▪ Risk of poisoning e.g. by S²⁻, CN⁻ or NH₃ ▪ Conductivity > 50 μS/cm ▪ Organic content < 20 vol % ▪ NOT hygienic or abrasive 	<ul style="list-style-type: none"> ▪ Batch reactors ▪ Mixture monitoring ▪ Neutralisation ▪ Make up water in chemical industry ▪ Dye and pigment synthesis 	<ul style="list-style-type: none"> ▪ HCN production ▪ Chemical process solutions

Memosens CPS41E
Ceraliquid CPS41



<ul style="list-style-type: none"> ▪ Fast response time due to ceramic junction and liquid filling ▪ Extended lifetime with outstanding poison resistance because of continuous reference refilling 	
<p>-15 °C to 80 °C (A glass), 0 °C to 135 °C (B glass) up to 11 bar_{abs}, KCl vessel CPY7B with counter pressure necessary</p> <p>1 to 12 (A glass), 0 to 14 (B glass) 120, 225, 360 and 425 mm Memosens and TOP68</p>	
<ul style="list-style-type: none"> ▪ Manual refilling of electrolyte vessel necessary 	<ul style="list-style-type: none"> ▶ gel-filled CPS11 "BT version", CPS11E "TA version", CPS16E or CPS71/CPS71E "TP version", CPS76E „TP version"

4. Selection of assembly

4.1 Flow chart for assembly selection

General considerations

Correct assembly selection requires consideration of the installation and application conditions as well as pH sensor selection.

Please be aware that several retractable assemblies are available in different versions suitable for either gel or liquid-filled sensors. Retrofitting from one version to another is either impossible or needs a lot of effort. Make sure that you select an assembly which fits with the pH sensor. See table 4.6 on page 48 for details.

For chemically demanding and safety relevant applications, ball-valve sealed assemblies should be preferred due to complete mechanical isolation during exchange process.

Manual retraction of assemblies with a sliding drive is only possible up to 2 bar process pressure, manual assemblies with rotary drive can be retracted at pressures up to 8 bar although the assemblies are suitable for higher pressures during normal operation. For retraction at a higher pressure you need a pneumatic version.

Same holds true for automatic measuring, cleaning and calibration. In case you want to use our Liquiline Control or Chemoclean Plus please select a pneumatically driven retractable assembly as most manual versions can not be converted.

When using 2 Memosens pH sensors for a measuring point - one in the application and the 2nd one the calibration / recovery cycle, retractable assemblies or bypass installations are required to enable exchange of pH sensors without interrupting the process.

In case of hygienic applications, the selection is based on process requirements (e.g. ..., you will find corresponding recommendations in the different sections).



Immersion type

Fixed installation

Retractable assembly with piston sealing

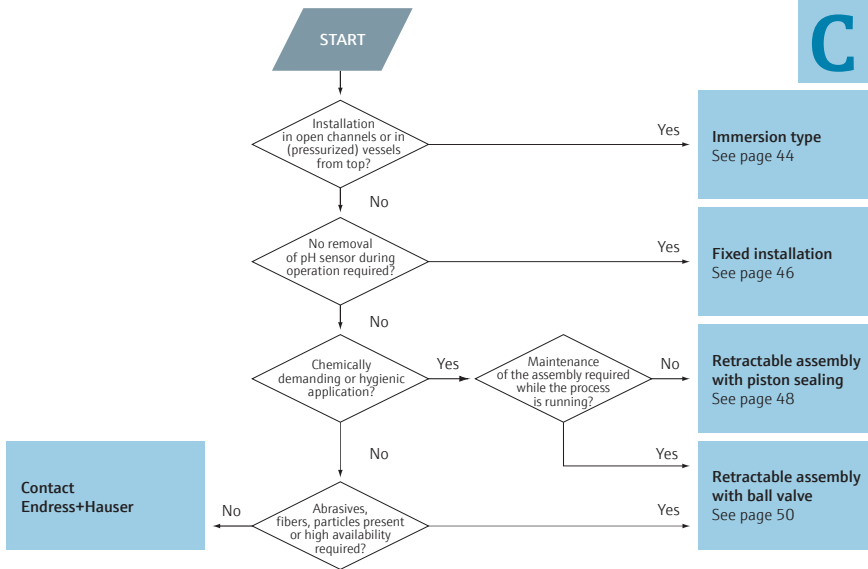

Retractable assembly with ball valve



4. Selection of assembly

4.2 Immersion type

C
Immersion
type

		Our proposal		
		Flexdip CPA112		Dipfit CPA111
				
Advantages		<ul style="list-style-type: none"> Modular system for different kinds of mounting e.g. exchangeable for one pH or turbidity sensor 		<ul style="list-style-type: none"> 3 sensor slots for redundant measurement Flexible immersion depth by chemically resistant pipes Spray cleaning head as option
Technical data		<ul style="list-style-type: none"> Process temperature: 0 to 60 °C Max. process pressure: 1 bar_{abs} Material of wetted parts: PVC; stainless steel 1.4404/316L, EPDM Process connection: Different holder systems, float ball, chain from Nylon hanging, pendulum frame mounting Immersion depth: 600 to 3600 mm 		<ul style="list-style-type: none"> Process temperature: -10 to 80 °C Max. process pressure: 1 to 5 bar_{abs} Material of wetted parts: Polypropylene (PP), EPDM Process connection: Flange DN 100, adjustable flange DN 100, hanging bracket Immersion depth: 500 to 3000 mm
Application limits		<ul style="list-style-type: none"> Long immersion depth or version for high lateral load like agitation on request Pressurization 		<ul style="list-style-type: none"> High lateral load like agitation
	► = alternative product	<ul style="list-style-type: none"> ► CPA111 ► CPA140 		<ul style="list-style-type: none"> ► CPA140

Installation in open channels, basins and in closed vessels from top

Immersion assemblies are usually used for installation in open channels and basins fixed by chains or on a rail. Versions with flanges can as well be used for installation of the sensor from the top of a vessel. Typical applications are e.g. municipal and industrial wastewater.



Dipfit CPA140



- 3 sensor slots for redundant measurement
- Robust process sealing thanks to the bayonet mounting method

-10 to 150 °C
1 to 11 bar_{abs}

PVDF, stainless steel 1.4404/316L,
EPDM, FKM, FFKM
Flange DN 80, ANSI 3" and JIS

500 to 2500 mm

- Service-friendly change of sensor
 - ▶ retractable CPA450 or CPA473

C



Immersion
type

4. Selection of assembly

4.3 Fixed installation

C

Fixed installation

		Our proposal: Standard	
		Flowfit CYA21 	Flowfit CPA250 
Advantages	<ul style="list-style-type: none"> ■ Compact design; ideal for limited space applications ■ Compatible with common tube fitting systems 	<ul style="list-style-type: none"> ■ 3 sensor slots for redundant measurement ■ Polypropylene (PP) flow through type ■ Easy calibration by detachable calibration vessel 	
Technical data	<ul style="list-style-type: none"> ■ Process temperature: 0 to 100°C ■ Max. process pressure: 1 to 17 bar_{abs} ■ Material of wetted parts: Stainless steel 1.4404/316L ■ Process connection: Pipe 6mm (OD) ■ Immersion depth: – 	<ul style="list-style-type: none"> ■ Process temperature: 0 to 80°C ■ Max. process pressure: 1 to 7 bar_{abs} ■ Material of wetted parts: Polypropylene (PP), EPDM ■ Process connection: Thread G1, NPT 1" ■ Immersion depth: – 	
Application limits	<ul style="list-style-type: none"> ▶ = alternative product ■ Redundant measurements, high flow capacity 	<ul style="list-style-type: none"> ▶ CPA240 	<ul style="list-style-type: none"> ■ Installation in tank or vessel ■ Temperature > 80 °C ▶ CPA640 or CPA842 ▶ CPA240, CYA21

Installation in pipes/bypass with flow through or insertion type assembly

Suitable for processes which do not need frequent replacement or calibration of pH sensors. For applications with pressure in pipe medium flow has to be interrupted in the pipe or bypass to get access to the sensor by an external valve.



Our proposal: hygienic

Flowfit CPA240



- 3 sensor slots for redundant measurement
- Different design (axis) of inlet and outlet of the fluid available

-10 to 150 °C
1 to 11 bar_{abs}

PVDF, 316L, FKM, FFKM

Thread or flanges DN 25; 90° or 180° between in- and outflow

–

- Large dimension e.g. panels in power stations
- Change of sensor under pressure

- ▶ CYA21
- ▶ retractable CPA871

Unifit CPA842



- Variety of process connections
- Effective solution especially for batch processes
- Design follows up-to-date hygienic engineering guidelines such as ASME BPE, EHEDG or 3-A

-15 to 140 °C
1 to 17 bar_{abs}

Stainless steel 1.4435/316L, EPDM-FDA, FKM-FDA, FFKM-FDA, silicone-FDA

Thread G 1¼", NPT, Tri-Clamp, Varivent, DN 25 and DN 50 dairy fitting Aseptic fitting DN50 thread DIN11864-1A

–

- Change of sensor under pressure in hygienic design

- ▶ retractable CPA875

Ecofit CPA640



- Adapter to G or NPT thread connections

-10 to 140 °C
1 to 7 bar_{abs}

PVDF, stainless steel 1.4404/316L or stainless steel 1.4435/316L, EPDM, FKM, FFKM

Thread G 1¼" or M25x1.5, NPT ½", ¾"

25 mm, 50 mm or 85 mm

- Only thread process connections

- ▶ CPA842

C



Fixed installation

4. Selection of assembly

4.4 Retractable assembly (with piston sealing)

C

Retractable assembly with piston sealing

	Our proposal: Standard	Our proposal: hygienic
	Cleanfit CPA871 	Cleanfit CPA875 
Advantages	<ul style="list-style-type: none"> Flexible retractable assembly for a broad range of applications Intelligent functions for highest process and personnel safety 	<ul style="list-style-type: none"> Hygienic design 3-A, FDA-listed materials and EHEDG certificate for a broad range of hygienic applications Double chamber with patented sealing principle for 100% sterile processes
Technical data	<ul style="list-style-type: none"> Process temperature: -10 to 140 °C (PVDF: -10 to 100 °C) Max. process pressure: manual: 1 to 9 bar_{abs'} pneu.: 1 to 17 bar_{abs} Material of wetted parts: Stainless steel 1.4404/316L, PEEK, Alloy C22, PVDF Seals: EPDM, FKM, FFKM Process connection: G 1¼", NPT 1½", Tri-clamp, dairy fitting, flanges Immersion depth: up to 135 mm 	<ul style="list-style-type: none"> Process temperature: -10 to 140 °C Max. process pressure: manual: 1 to 9 bar_{abs'} pneu.: 1 to 17 bar_{abs} Material of wetted parts: Stainless steel 1.4435/316L Process connection: G 1¼", Tri-clamp, aseptic, Neumo Biocontrol, Neumo Bioconnect, dairy fitting, Varivent flange Immersion depth: up to 80 mm
Application limits	<ul style="list-style-type: none"> Mechanical stability Soiling media (fibers) 	<ul style="list-style-type: none"> Relatively high investment costs Fixed installation with CPA842
▶ = alternative product	<ul style="list-style-type: none"> ▶ CPA472D ▶ CPA473, CPA450 	

Installation in pipe and vessels with piston sealing towards process

Manual and pneumatic



Our proposal: Heavy-duty

Cleanfit CPA472D



- Various materials available for best chemical compatibility
- Heavy-duty version available with flow chamber and sight glass as option
- High immersion depth up to 280 mm

-20 to 140 °C
1 to 11 bar_{abs}

Stainless steel 1.4571/316L, Alloy C22, PVDF,
PVDF conductive, PEEK

G 1¼", flanges DN 50/80, ANSI 2" JIS

up to 280 mm

- Relatively high investment costs

► CPA450

C



Retractable
assembly with
piston sealing

4. Selection of assembly

4.5 Retractable assembly (with ball valve)

C

Retractable assembly with ball valve

	Our proposal: manual	Our proposal: pneumatic
	Cleanfit CPA450 	Cleanfit CPA473 
Advantages	<ul style="list-style-type: none"> Variable immersion depths up to 700 mm Open sensor protection guard prevents fibers from sticking round the sensor Safety kit to protect of higher pressure 	<ul style="list-style-type: none"> Open sensor protection guard and tape wiper prevents fibers from sticking round the sensor e.g. media in pulp & paper, mining
Technical data	<ul style="list-style-type: none"> Process temperature: 0 to 130 °C Max. process pressure: 1 to 5 bar_{abs} retraction; 1 to 17 bar_{abs} static Material of wetted parts: SS 316L and Hastelloy C22, titanium, EPDM, FKM, FFKM Process connection: G 1¼", G 1½" NPT ½", flanges DN 32, ANSI 1½" and 2" Immersion depth: 3 types: from 100 up to 700 mm Operation: manual 	<ul style="list-style-type: none"> Process temperature: 0 to 100 °C Max. process pressure: 1 to 7 bar_{abs} Material of wetted parts: SS 316L, FKM, FFKM Process connection: G 1¼", dairy DN 50, flanges DN 50/ANSI Immersion depth: up to 230 mm Operation: manual/pneumatic
Application limits	<ul style="list-style-type: none"> Not for KCl electrodes Insertion on higher pressure 4 to 10 bar 	<ul style="list-style-type: none"> Remark: For sticky and abrasive medium choose "tape wiper option"
▶ = alternative product	▶ CPA473	

Installation in pipes and vessels with ball valve

- Ball valve offers safety process sealing
- Manual and/or pneumatic



Cleanfit CPA474



Cleanfit CPA451



- Suitable for aggressive medium
- Open sensor protection guard and tape wiper prevents fibers from sticking round the sensor e.g. media in pulp & paper, mining

- Suitable for CPF81/CPF81E
- Open sensor protection guard prevents fibers from sticking round the sensor

0 to 120 °C
1 to 7 bar_{abs}

Polypropylene (PP), PVDF, PEEK, EPDM, FKM, FFKM
G 1¼", dairy DN 50, flanges DN 50/ANSI up to 207 mm manual/pneumatic

0 to 80°C
1 to 3 bar_{abs} retractions;
1 to 11 bar_{abs} static
Stainless steel 1.4404/316L

G2" female, flange DN50 Iso 1092-1, flange 2" ANSI up to 270mm manual

- PP/PVDF/PEEK chemically not compatible

► CPA473

- Chemical resistivity, specifications

► 12 mm sensor with another Cleanfit assembly

C

Retractable assembly with ball valve

4. Selection of assembly

4.6 Required pH sensor length and immersion depth for various assemblies

		Maximum immersion depth ²⁾	Glass sensors			
			CPS11/ CPS11E/ CPS16E	CPS41/ CPS41E ¹⁾	CPS71/ CPS71E/ CPS76E	CPS91/ CPS91E/ CPS96E
CPA111		see note 3)	120 mm	120 mm	120 mm	120 mm
CYA112		see note 3), 5)	120 mm	–	120 mm	120 mm
CPA140		see note 3)	120 mm	120 mm	120 mm	120 mm
CPA240		not applicable	120 mm	120 mm	120 mm	120 mm
CYA21		not applicable	120 mm	120 mm	120 mm	120 mm
CPA250		not applicable	120 mm	120 mm	120 mm	120 mm
CPA842		73 mm	120 mm	120 mm	120 mm	120 mm
CPA640		85 mm	120 mm	120 mm	120 mm	120 mm
CPA450		see note 3)	120 mm	n/a	120 mm	120 mm
CPA472D	short	146 mm	225 mm	360 mm	225 mm	225 mm
	long	280 mm	360 mm	n/a	360 mm	360 mm
CPA473	short	100 mm	225 mm	425 mm	225 mm	225 mm
	long	230 mm	360 mm	n/a	360 mm	360 mm
CPA474	short	76 mm	225 mm	425 mm	225 mm	225 mm
	long	207 mm	360 mm	n/a	360 mm	360 mm
CPA871	basic short	36 mm	120 mm ^{*4)}	n/a	120 mm	120 mm
	basic long	78 mm	225 mm	225 mm	225 mm	225 mm
	immersion chamber short	135 mm	225 mm	n/a	225 mm	225 mm
	immersion chamber long	187 mm	360 mm	360 mm	360 mm	360 mm
CPA875	single chamber short	36 mm	225 mm	225 mm	225 mm	225 mm
	single chamber long	78 mm	225 mm 360 mm	n/a 360 mm	225 mm 360 mm	225 mm 360 mm
	double chamber	78 mm	225 mm 360 mm 360 mm	n/a 360 mm n/a	225 mm 360 mm 360 mm	225 mm 360 mm 360 mm

	ISFET		
	CPS47E ¹⁾	CPS77E	CPS97E
	120 mm	120 mm	120 mm
	120 mm	120 mm	120 mm
	120 mm	120 mm	120 mm
	120 mm	120 mm	120 mm
	120 mm	120 mm	120 mm
	120 mm	120 mm	120 mm
	120 mm	120 mm	120 mm
	120 mm	120 mm	120 mm
	120 mm	120 mm	120 mm
	120 mm	120 mm	120 mm
	n/a	120 mm	120 mm
	360 mm	225 mm	225 mm
	n/a	360 mm	360 mm
	425 mm	225 mm	225 mm
	n/a	360 mm	360 mm
	425 mm	225 mm	225 mm
	n/a	360 mm	360 mm
	n/a	120 mm	120 mm
	225 mm	225 mm	225 mm
	n/a	225 mm	225 mm
	360 mm	360 mm	360 mm
	225 mm	225 mm	225 mm
	n/a 360 mm	225 mm 360 mm	225 mm 360 mm
	n/a 360 mm n/a	225 mm 360 mm 360 mm	225 mm 360 mm 360 mm

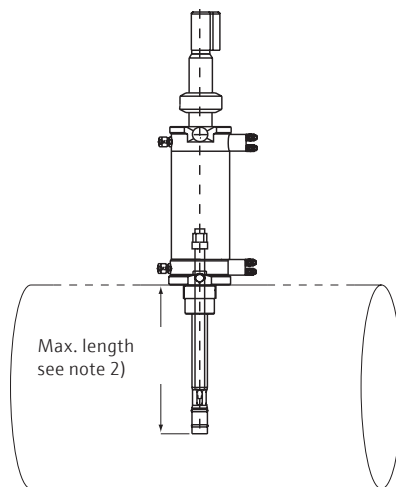

Notes:

- 1) Liquid-filled [KCl]
- 2) The indicated length is the maximum length which must be considered e.g. for installation in pipes to ensure mechanical space; depending on process connection it may be shorter for the individual assembly (see drawing)
- 3) Depending on length of immersion assembly
- 4) Not CPS16E
- 5) CPF81E can be combined with CYA112 or CPA451



5. Life cycle management of pH measuring loops

5.1 Optimum calibration concept for the lab thanks to Memosens and Memobase Plus

With Memosens technology, analog signals are converted to digital signals directly in the sensor. This is why the sensor is also the only component that must be checked and calibrated regularly. The cable and transmitter do not affect the measured value unlike in an analog system which can be sensitive to moisture and electromagnetic interferences.

Memosens sensors not only determine and transfer the measured value but also save additional process data. This data can include operating hours at higher temperatures, for example, or maximum temperatures occurring in the process. This information enables predictive maintenance. In addition, current calibration data such as the slope and zero point of the pH sensor are also saved. Using Memosens technology, you can therefore replace the sensor quickly and easily in the process with a clean, pre-calibrated sensor. The measured value controlling your process is thus available immediately once again.

Important maintenance measures such as sensor calibration can then take place in the comfortable surroundings of the laboratory – under constant and perfect conditions and with all of the necessary tools available there. This is much faster than at the site where the sensor is used in the process.

The Memobase Plus software acts as the perfect complement to support the concept of laboratory calibration. This sensor and data management software allows you to calibrate and check your sensors very easily. Furthermore, Memobase Plus saves all sensor and calibration data in a database allowing you to create visualizations and reports automatically and export data. In addition to pH glass sensors and pH ISFET sensors, the software supports sensors for ORP, conductivity and dissolved oxygen. Memobase Plus is available in 12 languages and linked to Endress+Hauser's W@M Portal. This enables professional life cycle management of all the sensors used in the process.

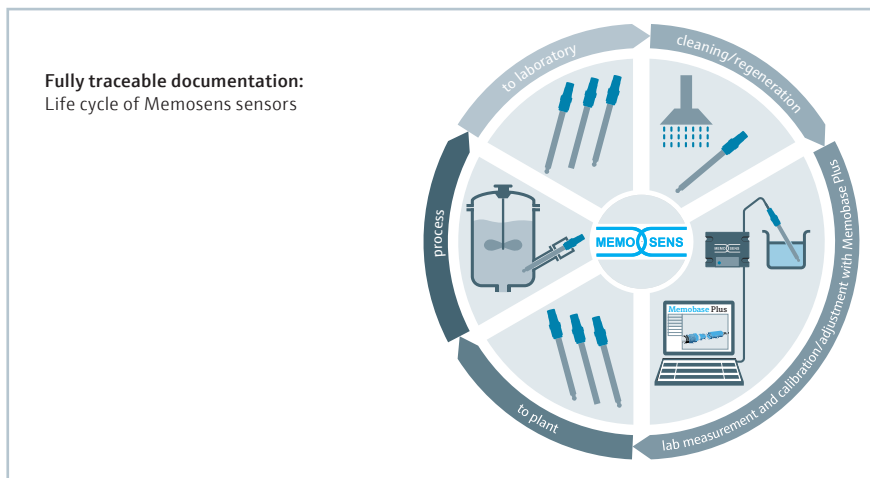

5.2 Fully automatic measuring, calibration and cleaning

Liquiline Control

If it's a case of upgrading a manual measuring point to a fully automated pH system, you will find the ideal solution in Liquiline Control CDC90. The system ensures continuous maintenance of the sensors. This guarantees a high degree of accuracy and the highest degree of availability of your pH measuring point. Thanks to its web-based technology, Liquiline Control CDC90 supports remote access from anywhere at any time – directly via your process control systems or any mobile device such as tablets, smartphones or notebooks.

Liquiline Control CDC90



Fully automatic pH measuring point with integrated control

- Calibration
- Cleaning
- Rinsing

Modbus
EtherNet/IP
PROFINET
GATEWAY
CPC UA



Liquiline with Chemoclean Plus

The Liquiline multiparameter transmitter with Chemoclean Plus is the variable solution for automatic sensor cleaning. Liquiline features four independent relays to control a retractable assembly and cleaner supply. The system is supplemented by a compact valve block thus offering the flexibility of a multichannel device together with the option of automatically cleaning the connected sensors.

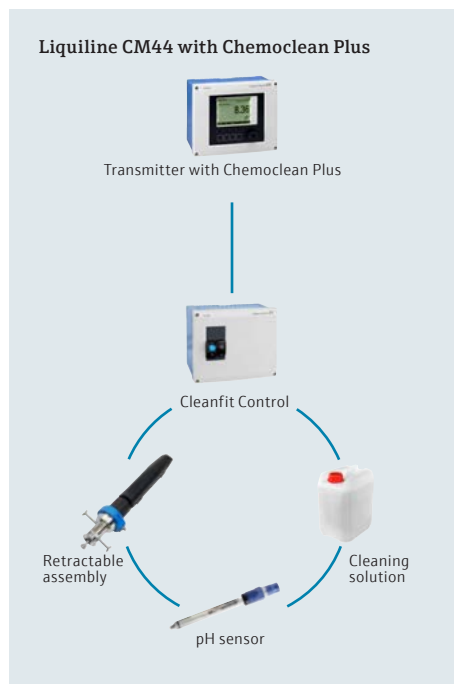

5. Life cycle management of pH loops

5.3 Lifetime of pH sensors

You might be wondering why there are so many different pH sensors and options available. The problem lies in the measuring principle. On the one hand the sensing element, glass or ISFET (ion selective field effect transistor) is directly in contact with the medium. Any deposits, abrasive particles, mechanical stress and aggressive chemicals will have an impact on the measurement accuracy and/or lifetime of the sensor. Additionally, the junction of the pH sensor brings the reference system in direct contact with the medium. Ions which react with the silver reference wire like e.g. sulfides and cyanides can destroy the reference system. Blockage of

the junction would interrupt the measurement and dilution of the reference solution changes the potential of the reference system. The latter effect is the reason why a pH sensor has to be calibrated and adjusted regularly. Problems with wet connectors or ground leaks are not any longer an issue with Memosens technology.

There is no reasonable answer to the question: What is the lifetime of the sensor? Sensor lifetime depends on sensor choice, cleaning intervals and of course your application. pH sensors have therefore to be considered as consumables.



5.4 Accreditation for permanent pH buffer laboratory

Correct measurement of the pH value not only serves to ensure that limit values are adhered to, but the pH value is also often used as a reference variable for product quality or used directly for control purposes. The requirements for pH measurement are extremely tough, and this applies across the entire measuring range of 14 orders of magnitude. Measurement accuracy and reproducibility begin and end with correct calibration of the pH measuring point.

For calibration, pH buffer solutions are used worldwide across all sectors. The zero point and slope of a pH sensor are important reference variables for the quality of a pH measurement. These are calculated using two different pH buffer solutions.



The accuracy of the later pH measurement in the process is directly dependent on the quality and accuracy of the specified pH value of the pH buffer solutions. For many years now, Endress+Hauser Conducta has been manufacturing quality buffers for the following pH values: 2.00, 4.00, 7.00, 9.00, 9.22, 10.00 and 12.00. They meet even the tough requirements of the life sciences industry and contain only FDA-listed preservatives.



Endress+Hauser Liquid Analysis underwent the DKD's demanding accreditation procedure in accordance with DIN EN ISO/IEC 17025:2005. On May 5, 2009, the accreditation body granted the authority to issue calibration certificates for pH buffer solutions. On August 31, 2020, the accreditation body renewed the accreditation for the permanent calibration laboratory in Waldheim, Saxony with the DAR registration number D-K-15193-01.

The accreditation is regularly repeated and confirms that the actual values and maximum deviations of the manufactured pH buffer solutions are determined in a manner that is correct and traceable. In the measuring range of pH 2 – 10, the smallest specifiable measuring uncertainty of 0.02 applies. In the measuring range of pH > 10 – 12.5, the smallest specifiable measuring uncertainty of 0.05 applies. This means that customers can rely completely on Endress+Hauser's pH quality buffers. Users from all industrial sectors benefit from the reliability of these calibration solutions.



5. Life cycle management of pH loops

5.5 Steam/water analysis systems

Steam production consumes a high amount of energy within industrial processes. The usage of high quality water in boiler applications of power plants and utility departments prevents corrosion processes and build-up. This ensures keeping the boiler efficiency high and therefore contributes to energy saving.

Endress+Hauser offers the full scope of equipment for the analysis of pure water for such boiler applications. As pressure and temperature are in most cases too high to measure directly in the process a sample conditioner is needed in front of the analytical panels. This is as well in the Endress+Hauser offering.



Notes

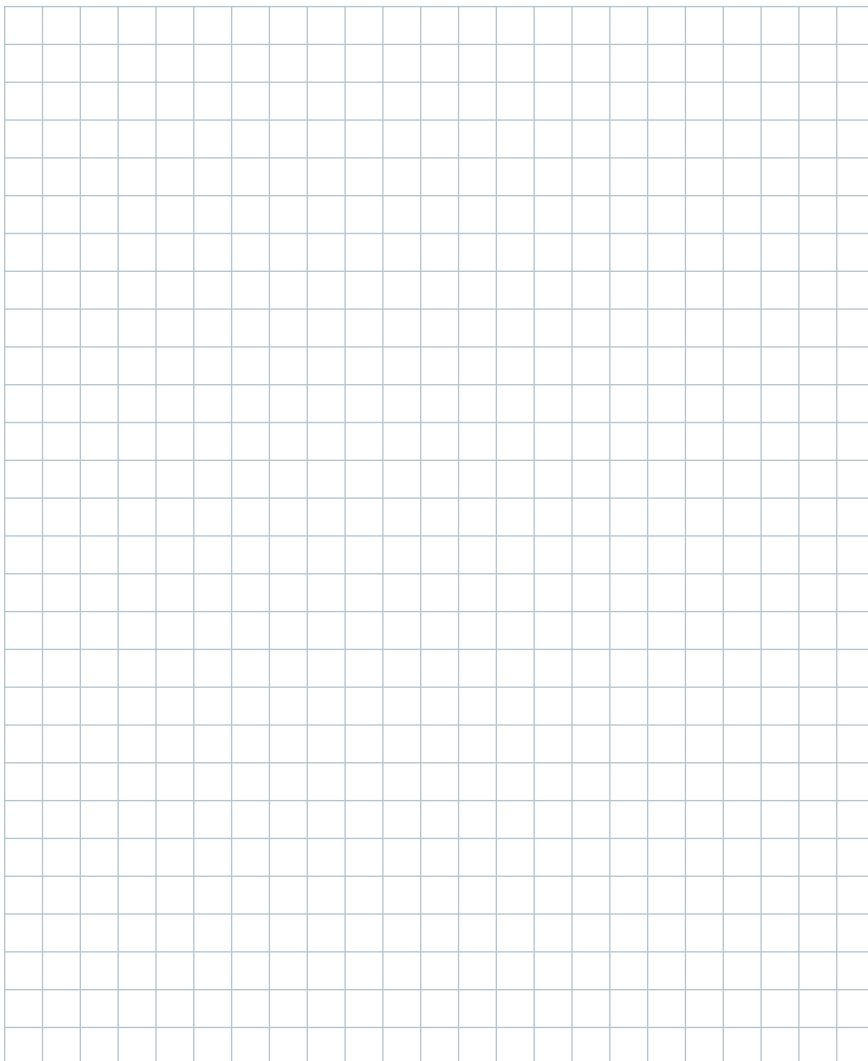

Supplementary documentation

- Parameter overview
FA00007C/07/en



Links

- Application Selection Software
www.endress.com/applicator
- Overview of all components
www.endress.com/pH
- Memosens technology
www.endress.com/memosens
- Liquiline Control CDC90
www.endress.com/CDC90

www.addresses.endress.com

CP00010C/07/en/16.21